



**GAS FURNACES**

**EL195UHNE**

**ELITE® SERIES**

**Upflow / Horizontal - Constant Torque Blower Motor - 60 Hz**

**RESIDENTIAL  
PRODUCT SPECIFICATIONS**

Bulletin No. 210812  
July 2020  
Supersedes September 2019



**ELITE®  
SERIES**



**AFUE - 95%**  
**Meets NO<sub>x</sub> Limit of 14 ng/J**  
**Input - 40,000 to 100,000 Btuh**  
**Nominal Add-on Cooling - 1 to 5 Tons**

**MODEL NUMBER IDENTIFICATION**

**EL 1 95 UH 060 N E 36 B**

Unit Type  
EL = Elite® Series

Stages  
1 = One-Stage

AFUE  
95 = 95%

Configuration  
UH = Upflow/Horizontal

Nominal Gas Heat Input  
040 = 40,000 Btuh  
060 = 60,000 Btuh  
080 = 80,000 Btuh  
100 = 100,000 Btuh

<sup>1</sup> Cabinet Width  
B = 17-1/2 in.  
C = 21 in.

Nominal Add-On Cooling Capacity  
36 = 1.5-3 tons  
48 = 2.5-4 tons  
60 = 3-5 tons

Blower  
E = High Efficiency Constant Torque Blower Motor

Ultra-Low NO<sub>x</sub>  
N = Units meet California Nitrogen Oxides Standard (14ng/J)

<sup>1</sup> Indoor coils with the same letter designation physically matches the furnace.

## FEATURE HIGHLIGHTS

1. Heat Exchanger Assembly
2. Secondary Heat Exchanger
3. SureLight® Hot Surface Ignitor
4. Modulating Gas Control Valve
5. Combustion Air Inducer
6. Thermal Switch
7. SureLight® Integrated Furnace Control
8. Contant Torque Direct Drive Blower
9. Insulated Cabinet
10. Safety Interlock Switch
11. Gas Piping And Electrical Inlets

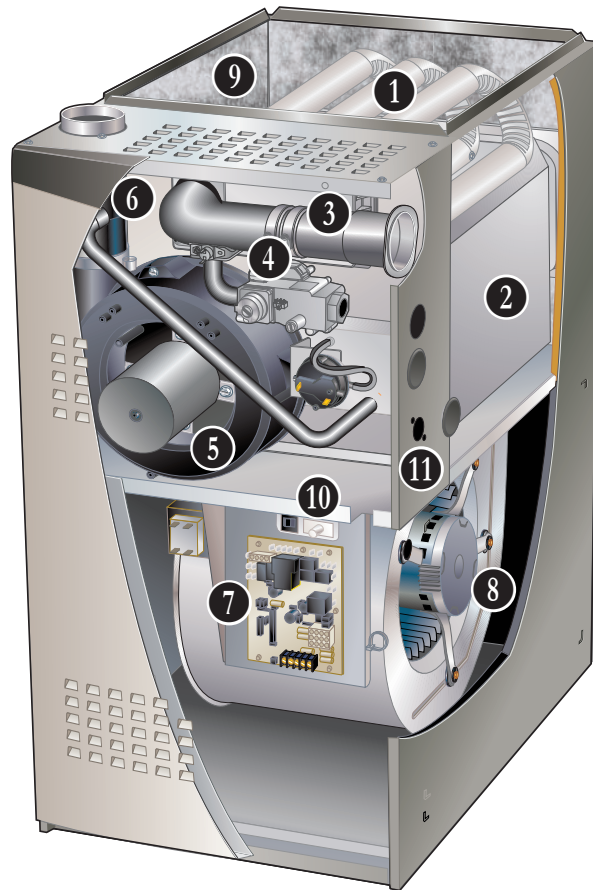

**NOTE - EL195UHNV 40K AND 100K INPUT FURNACES ARE NATURAL GAS ONLY!**  
**NOTE - NOT AVAILABLE IN ALL AREAS!**  
**CONTACT YOUR NEAREST LENNOX SALES OFFICE FOR DETAILS.**

## CONTENTS

Approvals And Warranty . . . . .	3
Blower Data . . . . .	12
Dimensions - Furnace/Coil Combined Dimensions . . . . .	17
Dimensions - Horizontal Position . . . . .	15
Dimensions - Optional Accessories . . . . .	16
Dimensions - Optional Accessories - Venting . . . . .	18
Dimensions - Upflow Position . . . . .	14
Features . . . . .	3
Gas Heat Accessories . . . . .	9
High Altitude Operation. . . . .	10
Installation Clearances . . . . .	11
Optional Accessories - Order Separately . . . . .	9
Specifications . . . . .	8
Vent Lengths - Uninsulated Exhaust Pipe In Unconditioned Space . . . . .	10

## APPROVALS AND WARRANTY

### APPROVALS

- AHRI Certified
- CSA International Certified
- Tested and rated according to US DOE test procedures and FTC labeling regulations
- Approved by the California Energy Commission and meets California Nitrogen Oxides Standard (NOx) limits of 14 ng/J
- Units are approved for installations from 0 - 4500 ft.
- ENERGY STAR® certified units are designed to use less energy, help save money on utility bills, and help protect the environment
- ISO 9001 Registered Manufacturing Quality System
- Blower data from unit tests conducted in Lennox Laboratory air test chamber

### WARRANTY

- Heat Exchanger:
  - Limited lifetime (twenty year transferable) in residential applications
  - Limited ten years in non-residential applications
- All other covered components:
  - Limited five years in residential installations
  - Limited one year in non-residential installations

**NOTE** - Refer to Lennox Equipment Limited Warranty certificate included with unit for specific details.

## FEATURES

### APPLICATIONS

- Input capacities of 40,000, 60,000, 80,000 and 100,000 Btuh
- Energy efficiency (AFUE) - 95%
- Upflow, horizontal-left or horizontal-right applications
- Utility room, alcove, closet, crawl space, basement or attic installation
- Lennox add-on indoor coils, high-efficiency air cleaners and humidifiers can easily be added to furnace
- Shipped factory assembled with all controls installed and wired
- Removable bottom seal panel shipped in place for side return air is easily removed for bottom/end return air applications
- Each unit factory test operated to ensure proper operation

### HEATING SYSTEM

- 1 **Heat Exchanger Assembly**
  - Heavy-gauge, aluminized steel heat exchanger
  - Tubular type design
  - Designed for normal expansion and contraction with maximum efficiency and minimum resistance to air flow
- 2 **Secondary heat exchanger condenser coil constructed of aluminum fins fitted to stainless steel tubes**
  - Coil is factory tested for leaks
  - Condensate drain header box assembly located on front of coil
  - Laboratory life cycle tested in excess of industry standards
  - Compact size of complete heat exchanger assembly permits low overall design of furnace cabinet

### **Header Box**

- Header box on end of condenser coil collects flue condensate for disposal through condensate drains
- Drains are located on each side of the cabinet for easy field installation of condensate drain trap
- Only one drain is used, the other drain is sealed
- Condensate drain trap is included for field installation

### **Flue Condensate Trap Assembly**

- Field installed outside the conditioned air stream
- Assembly can be mounted on either side of cabinet in upflow applications
- Assembly is mounted below the cabinet in horizontal applications
- Can also be mounted remotely (up to 5 ft. away) from unit
- See Installation Instructions
- 90° street elbow furnished for ease of drain trap installation
- Drain connection can be made with field provided PVC pipe, PVC coupling, or vinyl tubing with hose clamp
- Drain cap on trap allows easy cleaning and winterizing

## FEATURES

### HEATING SYSTEM (continued)

- 3 SureLight® Hot Surface Ignitor**
  - Tough, reliable, long-life, trouble-free performance
  - Silicon nitride ignitor
  - Cemented to steatite block for protection against current leakage
  - Ignition leads are constructed of nickel-plated copper and are enclosed in high temperature Teflon® insulation for dependable operation

- 4 Modulating Gas Control Valve**
  - 24 volt redundant combination modulating gas control valve combines manual shut off switch (On-Off), automatic electric valve (dual) and gas pressure regulation into a compact combination control

- 5 Combustion Air Inducer**
  - Shaded pole heavy duty blower prepurges heat exchanger and safely vents flue products
  - Operates only during heating cycle

#### Pressure Switch

- Proves Combustion Air Inducer operation before allowing gas valve to open

- 6 Thermal Switch**
  - Factory installed on air/fuel intake assembly
  - Provides protection from abnormal operating conditions
  - Automatic reset

#### Limit Control

- Primary limit is accurately located on vestibule panel on all units
- Automatic reset

### Optional Accessories

#### Natural Gas to LPG/Propane Conversion Kit (60K and 80K Input Furnaces Only)

- Required for field changeover from natural gas to LPG/Propane
- Includes gas and air orifices

#### Muffler (US Only)

- Significantly reduces outdoor operating sound levels
- Installed vertically in the exhaust piping
- See Optional Accessory Dimension Drawing

**NOTE** - Two-inch muffler is optional for the 100 input model with a maximum vent pipe length of up to 29 ft.  
Three-inch diameter muffler is optional for 100 input model.

**NOTE** - Three-inch muffler is optional for the 100 input model with a minimum vent pipe length of 30 ft.

### DIRECT VENT / NON-DIRECT VENT SEALED COMBUSTION SYSTEM

- Furnace features a “sealed combustion” system and can be installed in either Direct Vent or Non-Direct applications
- In Direct Vent applications, combustion air is supplied from outdoors and flue gases are discharged outdoors
- In Non-Direct Vent applications, combustion air is supplied from indoors and flue gases are discharged outdoors

**NOTE** - Lennox has approved the use of DuraVent® PolyPro® and Centrotherm InnoFlue® manufactured vent pipe and terminations as an alternative to PVC vent pipe. Must be ordered separately.  
Tested and listed to the ULC S636 standard in Canada.

**NOTE** - The polypropylene venting system must follow the uninsulated and unconditioned space vent lengths listed in the table on Page 10. Refer to the Installation Instructions for additional details.

### Optional Accessories

#### Flue Coupling

- Assists with exhaust flue piping connection and servicing
- Includes flexible one 2-inch rubber coupling and two adjustable bands
- Approved for all Lennox 90% furnaces

#### Vent Termination Kits

- Facilitates installation of combustion air intake pipe and flue exhaust pipe
- Refer to venting table in this bulletin to determine pipe size needed and proper termination kit required
- See Optional Accessories table and dimension drawings

#### Concentric Termination Kit - Direct Vent Applications

- 2 or 3 inch kit contains concentric termination assembly, reducer bushing and 45° elbow
- 2 inch kit for -070 model contains an outdoor exhaust accelerator
- Kit requires single hole penetration of roof or wall for installation
- Roof Termination Flashing Kit available for use 2 inch Kits
- CSA certified

#### Flush-Mount Termination Kit

- Kit contains flush-mount termination, accelerator, mounting template and hardware
- Kit may be used with 2, 2-1/2 or 3 inch pipe

## FEATURES

### **DIRECT VENT / NON-DIRECT VENT SEALED COMBUSTION SYSTEM (continued)**

#### Optional Accessories (continued)

##### Wall Assembly Termination Kits

##### Close Couple (US Only) - Direct Vent Applications

- 2 or 3 inch kit consists of close-couple, side-by-side PVC piping with galvanized steel wall cover plate for
- Seals and isolates intake and exhaust piping penetration of wall
- Piping spacing and length is sized for proper wall installations
- CSA certified

##### Close Couple WTK (Canada Only) - Direct Vent Applications

- 2 or 3 inch kit contains one insulated faceplate, one insulated exhaust pipe, elbow and fittings

##### Wall Ring - Direct Vent or Non-Direct Vent Applications

- 2 inch kit contains 2 stainless steel outside seal caps, 2 galvanized steel inside seal caps, 4 seal rings for the caps and 18 inch insulation sleeve
- Seals and isolates intake and exhaust piping penetration of wall

**NOTE** - Maintain a maximum of 6 inches between the inlet and outlet openings in the installation of the pipes.

##### Roof Termination Flashing Kit

- For vertical venting through a roof
- 3 inch kit contains two neoprene rubber roof flashings
- Vent pipe and insulation not furnished
- Flashing Kit can also be used with 2 inch Concentric Vent Termination Kits used in vertical venting rooftop applications

## CONTROLS

### **7 SureLight® Integrated Furnace Control**

- Contains all necessary controls and relays to operate furnace
- Combustion air inducer is operated by the integrated furnace control
- Prior to ignition, a pre-purge cycle for 15 seconds is initiated
- After the main burners are turned off, a post-purge cycle for 5 seconds is run
- Flame sensor assures safe and reliable operation
- Should loss of flame occur, the integrated furnace control will initiate 4 re-attempts at ignition before locking out unit operation for 60 minutes
- Watchguard type circuit automatically resets ignition controls after one hour of continuous thermostat demand after unit lockout, eliminating nuisance calls for service
- Fan control consists of adjustable blower timed-off delay (60, 90, 120, 180 seconds - factory setting 90 seconds) and fixed blower timed-on delay (30 seconds heating, 2 seconds cooling)
- Blower is automatically energized on thermostat demand for cooling demand (air conditioners)
- **Two Accessory Terminals** - Furnished for additional power supply requirements for 120 volt (less than 1 amp) power humidifiers and powered air cleaners
- **One Additional Accessory Terminal** - Furnished for power supply requirements for 24V (less than 0.5 amp) low voltage accessories.
- Ignition control has a single red LED to indicate status and as an aid in troubleshooting
- Last ten codes are stored in non-volatile memory (accessible by recall button on control) for servicing

### **24 Volt Transformer**

- Furnished and factory installed in control box
- 40VA transformer has circuit breaker wired in series

### **Field Wiring Make-Up Box**

- Furnished for line voltage wiring
- Factory installed internally on left side of furnace
- Box may be installed internally or externally on either side of furnace

## FEATURES

### CONTROLS (continued)

#### Optional Accessories

##### Blower Relay Kit

##### (For Use With Two-Stage Outdoor Units)

- Allows furnace blower speed changes when matched with two-stage air conditioners or heat pumps.

##### iComfort® E30 Smart Wi-Fi Thermostat

- Wi-Fi enabled, electronic 7-day, universal, multi-stage, programmable, touchscreen thermostat
- 3 Heat/2 Cool
- Auto-changeover
- Controls dehumidification during cooling mode and humidification during heating mode
- Offers enhanced capabilities including humidification / dehumidification / dewpoint measurement and control, Humiditrol® control, and equipment maintenance reminders
- Easy to read 7 in. color touchscreen (measured diagonally)
- LCD display with backlight shows the current and set temperature, time, inside relative humidity, system status (operating mode and schedules) and outside temperature (optional outdoor sensor required)
- Smooth Setback Recovery starts system early to achieve setpoint at start of program period
- Compressor short-cycle protection (5 minutes)
- Up to four separate schedules are available plus Schedule IQ™
- One-Touch Away Mode - A quick and easy way to set the cooling and heating setpoints while away
- Smart Away™ - Uses geo-fencing technology to determine when the homeowner is within a predetermined distance from the home to operate the system when leaving, away and arriving
- Wi-Fi remote monitoring and adjustment through a home wireless network for desktop PCs, laptops and apps for smartphones or tablets
- Smart home automation compatible with Apple HomeKit™, Amazon Alexa®, Google Assistant and IFTTT
- Service Dashboard features online real-time monitoring of installed iComfort® thermostats
- High Definition Color Display with Subbase, Smart Hub Controller, wallplate (for retrofit installations) furnished for easy installation
- See the iComfort® E30 Smart Wi-Fi Thermostat Product Specifications bulletin for more information



##### Remote Outdoor Temperature Sensor

- Used with the iComfort® E30 Smart Thermostat
- When installed outdoors, sensor allows thermostat to display outdoor temperature

**NOTE** - Sensor is required for Enhanced Dehumidification Control (EDA) applications.



##### Thermostat

- Thermostat is not furnished with unit
- See Lennox Price Book for selection

##### Furnace Twinning Kit

- Required to operate two furnaces simultaneously
- Kit consists of twinning relays, quick connect terminals and mounting hardware
- Used for single-stage heating/single-stage cooling with a single-stage thermostat

##### BLOWER

- Direct drive blower
- Statically and dynamically balanced
- Resiliently mounted
- Blower assembly easily removed for servicing

##### 8 Power Saver™ Constant Torque Blower Motor

- DC Brushless Motor
- High Efficiency Constant Torque
- ECM (Electronically Commutated Motor)
- Motor is programmed to provide constant torque at each of the selectable speeds
- Motor is controlled by the Integrated Furnace Control
- Blower speeds are easily changed on the integrated furnace control. See Blower Data tables

##### CABINET

- Low-profile, narrow width allows easy installation
- Heavy-gauge, cold rolled steel construction
- Pre-painted cabinet finish
- Flanges provided on supply air opening for ease of plenum connection or alignment with indoor coil
- 9 • Insulated with foil faced insulation on sides and back of heating compartment and mat faced insulation in blower compartment
- Sealed blower compartment
- Inner blower compartment access panel seals blower compartment from air leakage
- Cabinet door can be removed without any tools
- Complete service access
- 10 • Safety interlock switch automatically shuts off power to unit when blower compartment access door is removed
- 11 • Gas piping inlet is provided on right side of cabinet
- Electrical inlets are provided on both sides of cabinet.

##### Bottom/Side Return Air Entry

- Upflow/horizontal with bottom return air entry:
  - Remove furnished bottom seal panel from cabinet
- Upflow only with side return-air entry:
  - Corners are marked on either side of cabinet for return air cut-out
- See dimension drawings



## FEATURES

### **CABINET (continued)**

**NOTE** - 60C size units that require air volumes over 1800 cfm must have one of the following:

- Single side return air and Optional Return Air Base with transition that must accommodate required 20 x 25 x 1 inch air filter to maintain proper velocity
- Bottom return air
- Return air from both sides
- Bottom and one side return air
- See Blower Performance Tables for additional information

### **Coil Match-Up**

- All furnaces exactly match Lennox cased upflow indoor coils and horizontal indoor coils with same letter designation (A, B, C, D) in model number
- No adaptor required
- Engaging holes furnished on cabinet for alignment
- Lennox uncased coils match furnaces without any overhang but require an optional adaptor base or field fabricated transition to match furnace opening
- See coil bulletin for additional information

### **Low Leakage Cabinet**

- All models have less than 2% air leakage
- Meets ANSI/ASHRAE Standard 193-2010 "Method of Test for Determining the Air Tightness of HVAC Equipment"

### **Optional Accessories**

#### **Condensate Drain Heat Cable Kits**

- Self-limiting wattage heat cable prevents condensate drain from freezing in unconditioned areas
- Available in 6 or 24 ft. lengths

#### **Horizontal Suspension Kit**

- Provides suspension of unit and indoor coil in horizontal applications
- Allows complete service access
- Consists of corner mounted hanging brackets with vibration isolators, return air end support rail and hardware for assembly
- Metal hanging straps must be field provided

#### **Crawl Space Vent Drain Kit**

- Allows venting through a crawl space for upflow and horizontal applications
- Kit for Canada is certified to ULC S636
- Includes 2 or 3 inch sanitary tee, 2 inch PVC assembly, PVC boot and clamp
- Kit for Canada is certified to ULC S636

### **Return Air Base**

**NOTE** - On furnaces with side return air and condensate trap on the same side of the cabinet, a field fabricated transition or Return Air Base is required when using an IAQ product higher than 14-3/16 inches installed next to the unit and serviced from the front. IAQ products higher than 20 inches require a field fabricated transition.

**NOTE** - Must be used for 60C size models with air volumes over 1800 cfm in upflow applications when only one side return is required.

- Cabinet is shipped flat for easy field assembly
- Pre-painted steel to match the furnace
- See Dimension Drawing

### **High Performance Economizer (Commercial Applications Only)**

- Designed for applications requiring outdoor air to be utilized in a commercial HVAC system
- Allows the entry of fresh outdoor air for free cooling, reducing the requirement for mechanical cooling
- Heavy gauge galvanized steel cabinet lined with thick fiberglass insulation
- Mixed air sensor, outdoor air sensor and 24VAC transformer furnished
- Approved for California Title 24 building standards. ASHRAE 90.1-2010 compliant
- See separate Product Specifications bulletin for additional information and available control and sensor options

### **FILTER (not furnished)**

- Filter and provisions for external mounting must be field provided

### **Optional Accessories**

#### **Air Filter and Rack Kit for Horizontal Return Air (End) Applications**

- Washable or vacuum cleanable polyurethane frame type filter and external end return air rack
- Rack has filter door for servicing
- Flanges on rack for duct connection
- Field installed
- See dimension drawing

#### **Air Filter and Rack Kit for Upflow Side Return Air**

**NOTE** - Not for use with Return Air Base

- Washable or vacuum cleanable polyurethane frame type filter and external side return air rack available for field installation
- Available in single and ten pack kits
- Rack has filter door for servicing
- Flanges on rack for duct connection
- Field installs on either side of unit cabinet
- See dimension drawing

## SPECIFICATIONS

Gas Heating Performance		Model No.	EL195UH040NE36B	EL195UH060NE36B
		AHRI Ref. No.	201834895	201834898
		<sup>1</sup> AFUE	95%	95%
		Input - Btuh	40,000	60,000
		Output - Btuh	39,000	58,000
		Temperature rise range - °F	30 - 60	35 - 65
		Gas Manifold Pressure (in. w.g.) Nat. Gas / LPG/Propane	3.5 / N/A	3.5 / 4.0
		High static - in. w.g.	0.5	0.5
<b>Energy Star® Certified</b>			Yes	Yes
<b>Connections in.</b>	Intake / Exhaust Pipe (PVC)		2 / 2	2 / 2
	Gas pipe size IPS		1/2	1/2
	Condensate Drain Trap (PVC pipe) - i.d.		3/4	3/4
	with furnished 90° street elbow with field supplied (PVC coupling) - o.d.		3/4 slip x 3/4 Mipt 3/4 slip x 3/4 MPT	3/4 slip x 3/4 Mipt 3/4 slip x 3/4 MPT
<b>Indoor Blower</b>	Wheel nom. dia. x width - in.		10 x 8	10 x 8
	Motor Type		DC Brushless	DC Brushless
	Motor output - hp		1/2	1/2
	Tons of add-on cooling		1 - 2	1.5 - 3
	Air Volume Range - cfm		260 - 990	550 - 1380
<b>Electrical Data</b>	Voltage		120 volts - 60 hertz - 1 phase	
	Blower motor full load amps		6.8	6.8
	Maximum overcurrent protection		15	15
<b>Shipping Data</b>	lbs. - 1 package		122	128

NOTE - Filters and provisions for mounting are not furnished and must be field provided.

<sup>1</sup> Annual Fuel Utilization Efficiency based on DOE test procedures and according to FTC labeling regulations. Isolated combustion system rating for non-weatherized furnaces.

## SPECIFICATIONS

Gas Heating Performance		Model No.	EL195UH080NE48C	EL195UH100NE60C
		AHRI Ref. No.	201834896	201834897
		<sup>1</sup> AFUE	95%	95%
		Input - Btuh	80,000	100,000
		Output - Btuh	78,000	97,000
		Temperature rise range - °F	40 - 70	45 - 75
		Gas Manifold Pressure (in. w.g.) Nat. Gas / LPG/Propane	3.5 / 4.0	3.5 / N/A
		High static - in. w.g.	0.5	0.5
<b>Energy Star® Certified</b>			Yes	Yes
<b>Connections in.</b>	Intake / Exhaust Pipe (PVC)		2 / 2	2 / 2
	Gas pipe size IPS		1/2	1/2
	Condensate Drain Trap (PVC pipe) - i.d.		3/4	3/4
	with furnished 90° street elbow with field supplied (PVC coupling) - o.d.		3/4 slip x 3/4 Mipt 3/4 slip x 3/4 MPT	3/4 slip x 3/4 Mipt 3/4 slip x 3/4 MPT
<b>Indoor Blower</b>	Wheel nom. dia. x width - in.		10 x 10	11-1/2 x 10
	Motor Type		DC Brushless	DC Brushless
	Motor output - hp		3/4	1
	Tons of add-on cooling		2.5 - 4	3.5 - 5
	Air Volume Range - cfm		760 - 1740	1260 - 2405
<b>Electrical Data</b>	Voltage		120 volts - 60 hertz - 1 phase	
	Blower motor full load amps		8.4	10.9
	Maximum overcurrent protection		15	15
<b>Shipping Data</b>	lbs. - 1 package		148	157

NOTE - Filters and provisions for mounting are not furnished and must be field provided.

<sup>1</sup> Annual Fuel Utilization Efficiency based on DOE test procedures and according to FTC labeling regulations. Isolated combustion system rating for non-weatherized furnaces.



## OPTIONAL ACCESSORIES - ORDER SEPARATELY

			"B" Width Models	"C" Width Models
<b>CABINET ACCESSORIES</b>				
Horizontal Suspension Kit - Horizontal only			51W10	51W10
Return Air Base - Upflow only			50W98	50W99
High Performance Economizer (Commercial Only)			10U53	10U53
<b>CONDENSATE DRAIN KITS</b>				
Condensate Drain Heat Cable	6 ft.		26K68	26K68
	24 ft.		26K69	26K69
Crawl Space Vent Drain Kit	US		51W18	51W18
	Canada		15Z70	15Z70
<b>CONTROLS</b>				
Blower Relay Kit (for two-stage outdoor units)			85W66	85W66
Furnace Twinning Kit			16W72	16W72
iComfort® E30 Smart Thermostat			15S63	15S63
Remote Outdoor Temperature Sensor			X2658	X2658
<b>FILTER KITS</b>				
<sup>1</sup> Air Filter and Rack Kit	Horizontal (end)	Size of filter - in.	87L96 - 18 x 25 x 1	87L97 - 20 x 25 x 1
	Side Return	Single	44J22	44J22
		Ten Pack	66K63	66K63
		Size of filter - in.	16 x 25 x 1	16 x 25 x 1
<b>TERMINATION KITS</b>				
See Installation Instructions for specific venting information.				
Termination Kits - Direct Vent Applications Only	Concentric	US - 2 in.	71M80	69M29
		3 in.	---	60L46
		Canada - 2 in.	44W92	44W92
		3 in.	---	44W93
	Flush-Mount	US - 2, 2-1/2 or 3 in.	51W11	51W11
		Canada - 2, 2-1/2 or 3 in.	51W12	51W12
	Wall - Close Couple	US - 2 in.	22G44	---
		3 in.	44J40	44J40
Wall - Close Couple WTK	Canada - 2 in.	30G28	---	
	3 in.	81J20	81J20	
Termination Kits - Direct or Non-Direct Vent	Roof	2 in.	15F75	15F75
	Wall Ring Kit	2 in.	15F74	<sup>3</sup> 15F74
Roof Termination Flashing Kit - Direct or Non-Direct Vent (2 flashings)		3 in.	44J41	44J41
<b>VENTING</b>				
Flue Coupling		2 in.	17H92	17H92

<sup>1</sup> Cleanable polyurethane frame type filter.

<sup>2</sup> Kits contain enough parts for two, non-direct vent installations.

<sup>3</sup> Non-direct vent only.

NOTE - Termination Kits (44W92, 44W93, 30G28, 51W12, 51W19, 81J20) and Crawl Space Vent Drain Kit (15Z70) are certified to ULC S636 standard for use in Canada only.

## GAS HEAT ACCESSORIES

Input	Natural Gas to LPG/Propane Kit
	0 - 4500 ft.
040	N/A
060	19K05
080	19K06
100	N/A

NOTE - Natural Gas to LPG/Propane Kit is not available for 40K and 100K Input furnaces.

## HIGH ALTITUDE OPERATION

NOTE - Units may be installed at altitudes up to 4500 ft. above sea level without any modification. No modifications are required. At altitudes above 2000 ft. the furnace will naturally derate approximately 10%.

## OUTDOOR TERMINATION KIT USAGE

Input Size	Vent Pipe Diameter (in.)	Standard Terminations					Concentric Terminations			Muffler
		Flush Mount Kit	Wall Kit		Wall Ring Kit	Field Fabricated Exhaust Accelerator Size Required	Concentric Kit			
			2 inch	3 inch	2 inch		1-1/2 inch	2 inch	3 inch	
			51W11 (US) <sup>4</sup> 51W12 (CA)	22G44 (US) <sup>4</sup> 30G28 (CA)	44J40 (US) <sup>4</sup> 81J20 (CA)		15F74	71M80 (US) <sup>4</sup> 44W92 (CA)	69M29 (US) <sup>4</sup> 44W92 (CA)	60L46 (US) <sup>4</sup> 44W93 (CA)
040	2	<sup>3</sup> YES	YES	<sup>1</sup> YES	YES	1-1/2 in.	<sup>2</sup> YES	---	---	YES
	3	<sup>3</sup> YES	YES	<sup>1</sup> YES	YES	1-1/2 in.	<sup>2</sup> YES	---	---	YES
060	2	<sup>3</sup> YES	YES	<sup>1</sup> YES	YES	1-1/2 in.	<sup>2</sup> YES	---	---	YES
	3	<sup>3</sup> YES	YES	<sup>1</sup> YES	YES	1-1/2 in.	<sup>2</sup> YES	---	---	YES
080	2	<sup>3</sup> YES	---	YES	<sup>1</sup> YES	2 in.	---	YES	YES	YES
	3	<sup>3</sup> YES	---	YES	<sup>1</sup> YES	2 in.	---	YES	YES	YES
100	2	YES	---	YES	---	2 in.	---	YES	YES	<sup>5</sup> YES
	3	YES	---	YES	---	2 in.	---	YES	YES	<sup>5</sup> YES

NOTE - Standard Terminations do not include any vent pipe or elbows external to the structure.

Any vent pipe or elbows external to the structure must be included in total vent length calculations. See Vent Length Tables.

<sup>1</sup> Requires field provided 1-1/2 in. outdoor exhaust accelerator.

<sup>2</sup> Concentric Kits 71M80 and 44W92 include 1-1/2 in. outdoor exhaust accelerator, required when used with 040 and 060 input models. Accelerator is not used with 080 or 100 input models.

<sup>3</sup> Flush Mount Kit 51W11 and 51W12 includes 1-1/2 in. outdoor exhaust accelerator, required when used with 040, 060 and 080 input models. Accelerator is not used with 100 input models.

<sup>4</sup> Termination Kits 30G28, 44W92, 44W93, 51W12 and 81J20 are certified to ULC S636 standard for use in Canada only.

<sup>5</sup> Two-inch diameter muffler 15Y66 is optional for 100 input model with a maximum vent pipe length of up to 29 ft.

Three-inch diameter muffler 16A56 is optional for 100 input model with a minimum vent pipe length of 30 ft.

## VENT LENGTHS - UNINSULATED EXHAUST PIPE IN UNCONDITIONED SPACE

<sup>1</sup> Winter Design Temperatures	Vent Pipe Diameter	Unit Input Size							
		040		060		080		100	
		Maximum Un-Insulated Exhaust Vent Length (ft.)							
		PVC	PolyPro InnoFlue	PVC	PolyPro InnoFlue	PVC	PolyPro InnoFlue	PVC	PolyPro InnoFlue
32 to 21°F	2 in.	18	16	31	28	50	48	30	30
	3 in.	9	9	18	18	35	35	47	47
20 to 1°F	2 in.	9	8	18	16	32	29	30	30
	3 in.	N/A	N/A	8	8	19	19	26	26
0 to -20°F	2 in.	5	N/A	12	10	22	19	30	27
	3 in.	N/A	N/A	N/A	N/A	10	10	16	16

NOTE - Concentric terminations are equivalent to 5 ft. of straight pipe and should be included when measuring total pipe length.

<sup>1</sup> Refer to 99% Minimum Design Temperature table provided in the current edition of ASHRAE Handbook-Fundamentals.

PolyPro® poly-propylene vent pipe is a registered trademark of DuraVent®.

InnoFlue® is a registered trademark of Centrotherm Eco Systems.

## VENT LENGTHS

### STANDARD TERMINATION AT ELEVATION 0 - 4500 ft.

	Pipe Size	2 in.			3 in.		
	Input	040	060	080	040	060	080
No. of 90 ELL	1	81	66	44	138	137	118
	2	76	61	39	133	132	113
	3	71	56	34	128	127	108
	4	66	51	29	123	122	103
	5	61	46	24	118	117	98
	6	56	41	19	113	112	93
	7	51	36	14	108	107	88
	8	46	31	N/A	103	102	83
	9	41	26	N/A	98	97	78
	10	36	21	N/A	93	92	73

### CONCENTRIC TERMINATION AT ELEVATION 0 - 4500 ft.

	Pipe Size	2 in.			3 in.		
	Input	040	060	080	040	060	080
No. of 90 ELL	1	73	58	42	121	121	114
	2	68	53	37	116	116	109
	3	63	48	32	111	111	104
	4	58	43	27	106	106	99
	5	53	38	22	101	101	94
	6	48	33	17	96	96	89
	7	43	28	12	91	91	84
	8	38	23	N/A	86	86	79
	9	33	18	N/A	81	81	74
	10	28	13	N/A	76	76	69

## VENT LENGTHS (EXHAUST) - VENTILATED ATTIC OR CRAWLSPACE INTAKE AIR - FEET

### STANDARD TERMINATION AT ELEVATION 0 - 4500 ft.

	Pipe Size	2 in.			3 in.		
	Input	040	060	080	040	060	080
No. of 90 ELL	1	71	56	34	118	117	98
	2	66	51	29	113	112	93
	3	61	46	24	108	107	88
	4	56	41	19	103	102	83
	5	51	36	14	98	97	78
	6	46	31	9	93	92	73
	7	41	26	4	88	87	68
	8	36	21	N/A	83	82	63
	9	31	16	N/A	78	77	58
	10	26	11	N/A	73	72	53

## INSTALLATION CLEARANCES

Sides	<sup>1</sup> 1 inches (25 mm)
Rear	1 inches (25 mm)
Top/Plenum	1 inch (25 mm)
Front	1 inches (25 mm)
Front (service/alcove)	24 inches (610 mm)
Floor	<sup>2</sup> Combustible

NOTE – Air for combustion must conform to the methods outlined in the National Fuel Gas Code (NFPA 54/ANSI-Z223.1) or the National Standard of Canada CAN/CSA-B149.1 Natural Gas and Propane Installation Code™.

NOTE – In the U.S. flue sizing must conform to the methods outlined in the current National Fuel Gas Code (NFPA 54/ANSI-Z223.1) or applicable provisions of local building codes. In Canada flue sizing must conform to the methods outlined in National Standard of Canada CAN/CSA-B149.1.

<sup>1</sup> Allow proper clearances to accommodate condensate trap and vent pipe installation.

<sup>2</sup> Do not install the furnace directly on carpeting, tile, or other combustible materials other than wood flooring.

## BLOWER DATA

### EL195UH040NE36B PERFORMANCE (Less Filter)

External Static Pressure in. w.g.	Air Volume / Watts at Various Blower Speeds									
	High (Black)		Medium-High (Brown)		Medium (Blue)		Medium-Low (Yellow)		Low (Red)	
	cfm	Watts	cfm	Watts	cfm	Watts	cfm	Watts	cfm	Watts
0.00	1450	350	1280	247	1190	200	966	112	902	89
0.10	1429	360	1268	257	1171	207	939	119	875	99
0.20	1400	371	1248	267	1139	212	894	124	850	110
0.30	1377	381	1222	279	1112	223	872	131	800	114
0.40	1350	391	1195	286	1084	235	829	138	778	122
0.50	1317	401	1156	298	1043	240	794	147	724	129
0.60	1285	408	1127	308	1019	252	754	151	690	142
0.70	1233	390	1107	316	987	259	708	161	633	144
0.80	1160	370	1077	322	955	270	661	167	607	149

### EL195UH060NE36B PERFORMANCE (Less Filter)

External Static Pressure in. w.g.	Air Volume / Watts at Various Blower Speeds									
	High (Black)		Medium-High (Brown)		Medium (Blue)		Medium-Low (Yellow)		Low (Red)	
	cfm	Watts	cfm	Watts	cfm	Watts	cfm	Watts	cfm	Watts
0.00	1477	338	1289	240	1189	188	940	99	905	88
0.10	1431	353	1262	254	1160	200	918	109	873	97
0.20	1401	360	1244	263	1135	209	894	121	839	108
0.30	1372	374	1215	270	1110	221	852	126	798	113
0.40	1352	387	1189	282	1074	226	821	136	772	123
0.50	1324	391	1165	292	1050	241	786	146	728	130
0.60	1296	403	1130	302	1011	252	741	150	691	140
0.70	1255	406	1102	313	988	258	703	161	641	144
0.80	1190	386	1073	326	962	267	664	167	606	153

### EL195UH080NE48C PERFORMANCE (Less Filter)

External Static Pressure in. w.g.	Air Volume / Watts at Various Blower Speeds									
	High (Black)		Medium-High (Brown)		Medium (Blue)		Medium-Low (Yellow)		Low (Red)	
	cfm	Watts	cfm	Watts	cfm	Watts	cfm	Watts	cfm	Watts
0.00	1702	381	1502	270	1375	195	1298	169	1189	132
0.10	1688	418	1479	287	1349	220	1258	187	1136	144
0.20	1660	443	1450	304	1321	242	1215	203	1084	158
0.30	1627	458	1403	321	1282	255	1172	215	1030	172
0.40	1577	475	1370	337	1234	272	1131	231	990	188
0.50	1540	483	1329	352	1191	288	1085	245	933	195
0.60	1441	457	1291	369	1146	301	1045	259	883	203
0.70	1293	402	1249	380	1102	315	992	271	830	216
0.80	1144	365	1122	351	1053	326	951	285	809	219

## BLOWER DATA

### EL195UH100NE60C PERFORMANCE (Less Filter)

External Static Pressure in. w.g.	Air Volume / Watts at Different Blower Speeds																			
	Bottom Return Air, Side Return Air with Return Air from Both Sides or Return Air from Bottom and One Side.										Single Side Return Air – Air volumes in bold (over 1800 cfm) require Optional Return Air Base and field fabricated transition to accommodate 20 x 25 x 1 in. air filter in order to maintain proper air velocity.									
	High (Black)		Medium-High (Brown)		Medium (Blue)		Medium-Low (Yellow)		Low (Red)		High (Black)		Medium-High (Brown)		Medium (Blue)		Medium-Low (Yellow)		Low (Red)	
	cfm	Watts	cfm	Watts	cfm	Watts	cfm	Watts	cfm	Watts	cfm	Watts	cfm	Watts	cfm	Watts	cfm	Watts	cfm	Watts
0.00	2156	722	1922	497	1723	370	1589	215	1420	211	<b>2102</b>	<b>118</b>	<b>1833</b>	<b>489</b>	1688	170	1590	300	1375	209
0.10	2112	738	1851	511	1681	388	1552	326	1380	227	<b>2064</b>	<b>730</b>	<b>1809</b>	<b>504</b>	1658	384	1540	314	1347	224
0.20	2076	748	1808	533	1636	403	1525	334	1340	244	<b>2038</b>	<b>749</b>	1789	514	1623	402	1507	331	1325	242
0.30	2035	768	1782	542	1604	425	1488	349	1290	259	<b>2011</b>	<b>760</b>	1761	531	1594	413	1472	348	1266	246
0.40	2009	772	1749	558	1572	433	1441	362	1248	266	<b>1968</b>	<b>770</b>	1726	549	1561	431	1435	355	1247	264
0.50	1942	776	1715	580	1533	452	1424	374	1213	281	<b>1920</b>	<b>776</b>	1685	560	1527	443	1394	374	1199	278
0.60	1881	746	1681	584	1512	468	1357	382	1157	293	<b>1849</b>	<b>741</b>	1660	578	1489	455	1356	379	1154	286
0.70	1790	715	1634	599	1459	474	1319	401	1136	306	1777	723	1622	593	1439	473	1317	395	1124	301
0.80	1702	679	1582	613	1432	491	1300	418	1084	312	1682	681	1588	602	1407	488	1288	408	1067	308

## DIMENSIONS - UPFLOW POSITION

<sup>1</sup> NOTE - 60C size units that require air volumes over 1800 cfm must have one of the following:

1. Single side return air and Optional Return Air Base with transition that must accommodate required 20 x 25 x 1 inch (508 x 635 x 25 mm) air filter to maintain proper velocity.

2. Bottom return air.

3. Return air from both sides.

4. Bottom and one side return air.

See Blower Performance Tables for additional information.

<sup>2</sup> Optional Side Return Air Filter Kit is not for use with the Optional Return Air Base.

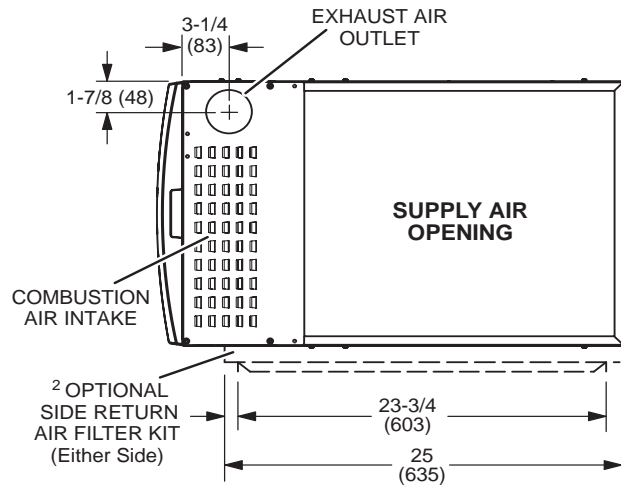

**TOP VIEW**

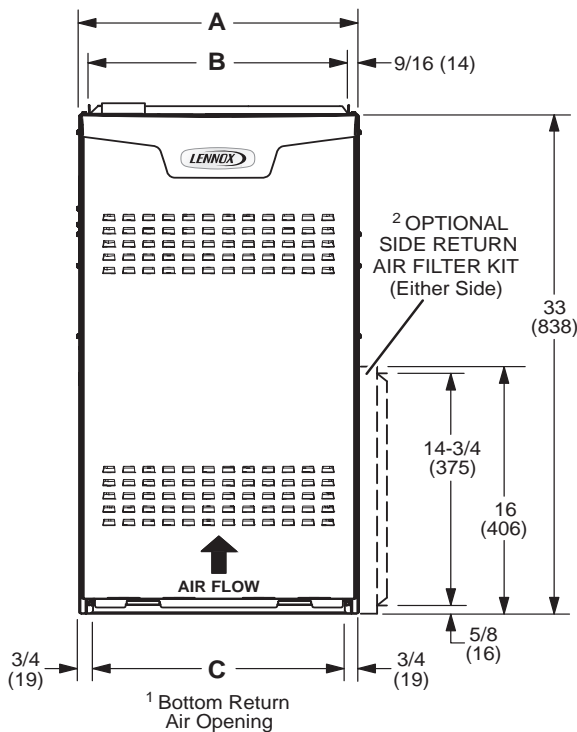

**FRONT VIEW**

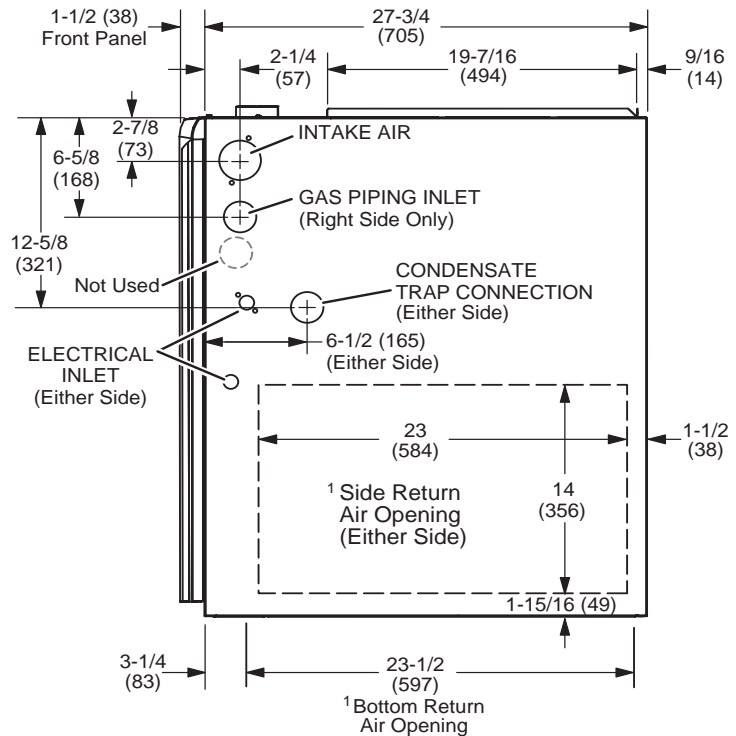

**SIDE VIEW**

Model No.	A		B		C	
	in.	mm	in.	mm	in.	mm
EL195UH040NE36B EL195UH060NE36B	17-1/2	445	16-3/8	416	16	406
EL195UH080NE48C EL195UH100NE60C	21	533	19-7/8	505	19-1/2	495



# DIMENSIONS - HORIZONTAL POSITION

## LEFT-HAND AIR DISCHARGE

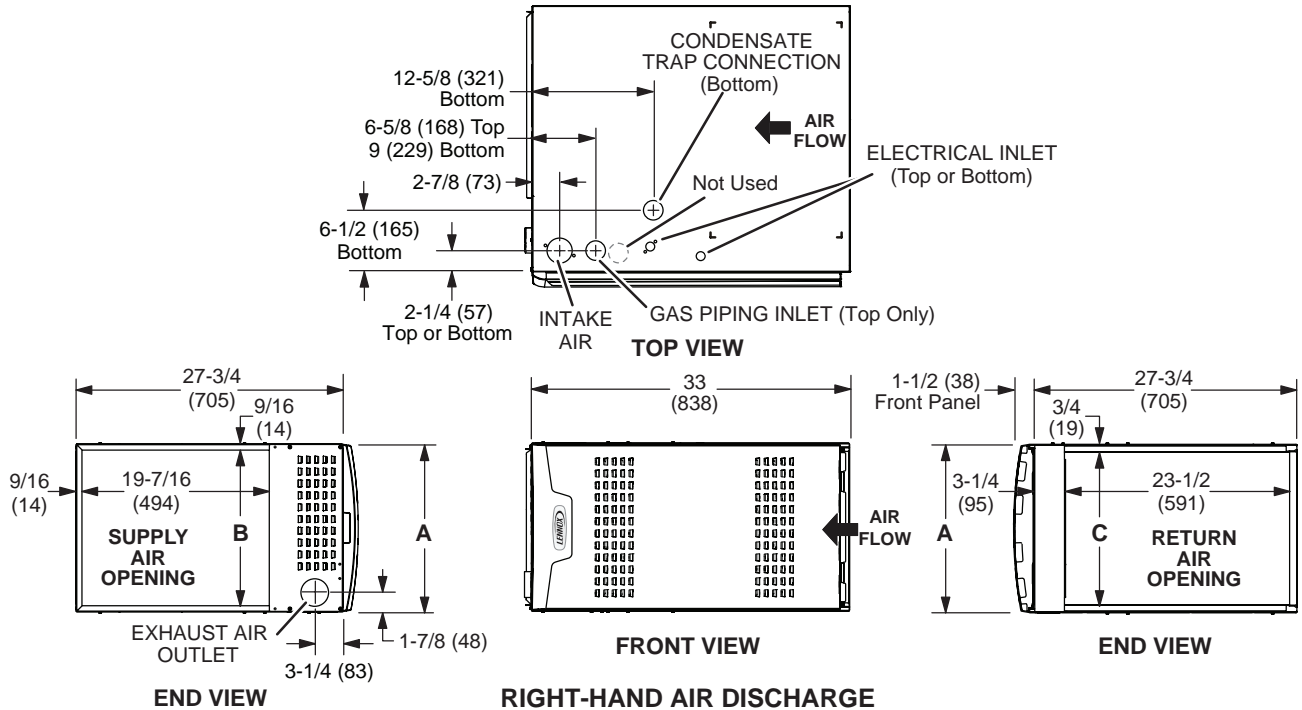

## RIGHT-HAND AIR DISCHARGE

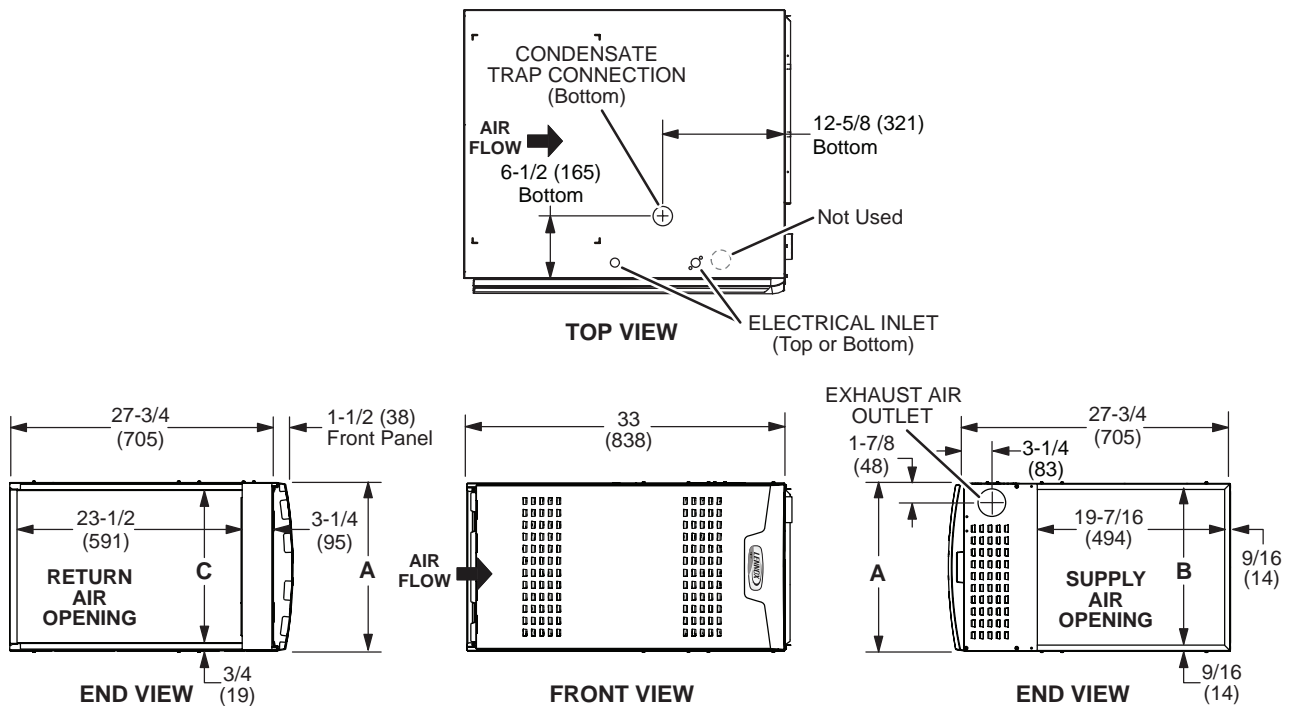

Model No.	A		B		C	
	in.	mm	in.	mm	in.	mm
EL195UH040NE36B EL195UH060NE36B	17-1/2	445	16-3/8	416	16	406
EL195UH080NE48C EL195UH100NE60C	21	533	19-7/8	505	19-1/2	495

## DIMENSIONS - OPTIONAL ACCESSORIES

### HORIZONTAL (END) FILTER KIT

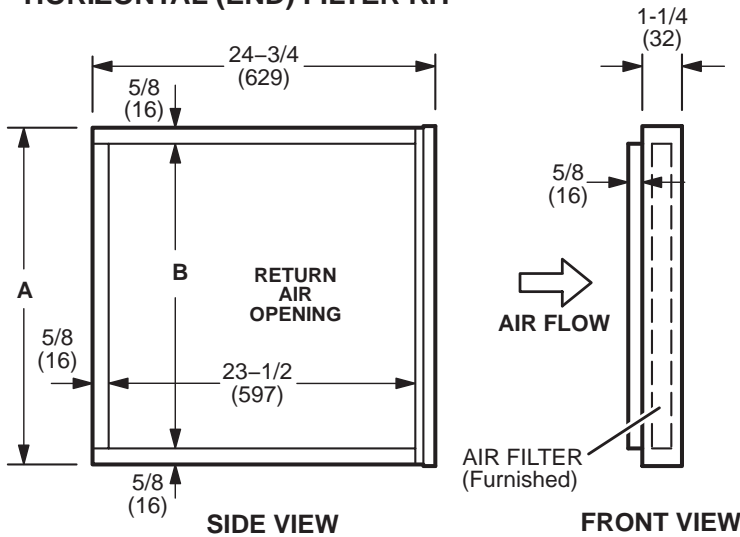

Furnace Cabinet Width	Catalog Number	A		B	
		in.	mm	in.	mm
B	87L96	18	457	16-3/4	425
C	87L97	21	533	18-3/4	476

### Optional Return Air Base (Upflow Applications Only - For use with B and C cabinets)

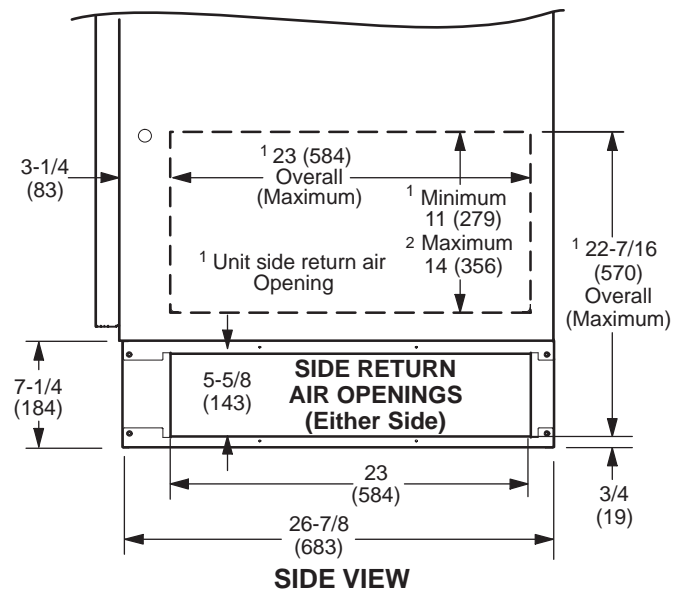
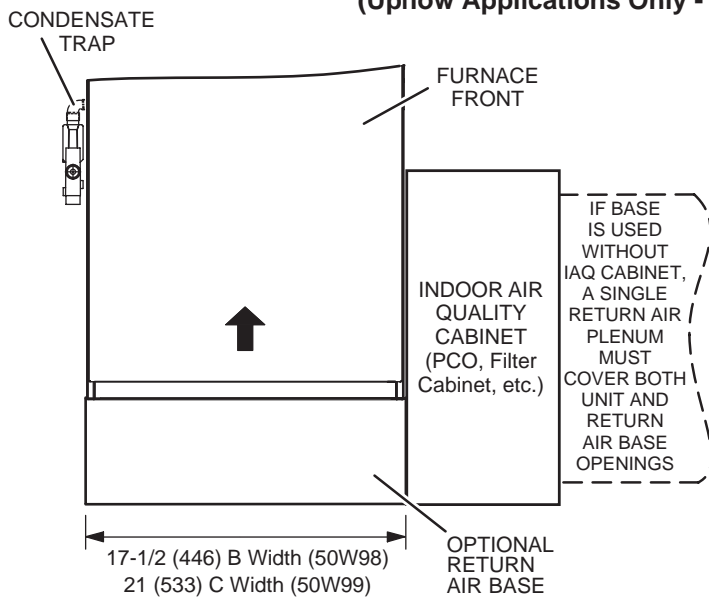

**NOTE-** Optional Side Return Air Filter Kits are not for use with Optional Return Air Base.

<sup>1</sup> Both the unit return air opening and the base return air opening must be covered by a single plenum or IAQ cabinet. Minimum unit side return air opening dimensions for units requiring 1800 cfm or more of air (W x H): 23 x 11 in. (584 x 279 mm). The opening can be cut as needed to accommodate plenum or IAQ cabinet while maintaining dimensions shown. Side return air openings must be cut in the field. There are cutting guides stenciled on the cabinet for the side return air opening. The size of the opening must not extend beyond the markings on the furnace cabinet.

<sup>2</sup> To minimize pressure drop, the largest opening height possible, up to 14 in. (356 mm), is preferred.

## DIMENSIONS - FURNACE/COIL COMBINED DIMENSIONS

### UPFLOW POSITION

Model No			C35/C37/CX35/CX38 Cased				C35 Uncased			
			A		B		A		B	
C35/CX35	C37	CX38	in.	mm	in.	mm	in.	mm	in.	mm
C35/CX35-18/24A C35/CX35-18/24B	---	---	16-1/2	419	49-1/2	1257	14-1/8	359	47-1/8	1197
C35/CX35-24A C35/CX35-24B	C37-25A C37-25B	CX38-25A CX38-25B	18-1/2	470	51-1/2	1308	16-3/8	416	49-3/8	1254
---	---	CX38-30A	20-1/2	521	53-1/2	1359	---	---	---	---
C35/CX35-30A C35/CX35-30B	C37-31A C37-31B	CX38-31A CX38-31B	22-1/2	572	55-1/2	1410	20-3/4	527	53-3/4	1365
C35/CX35-30/36A C35/CX35-30/36B C35/CX35-30/36C	C37-36A C37-36B C37-36C	CX38-36A CX38-36B CX38-36C	24-1/2	622	57-1/2	1461	22-1/4	565	55-1/4	1403
C35/CX35-36A C35/CX35-36B	C37-38A C37-38B	CX38-38A CX38-38B	24-1/2	622	57-1/2	1461	22-3/8	568	55-3/8	1407
---	C37-42B	CX38-42B	24-1/2	622	57-1/2	1461	---	---	---	---
C35/CX35-48B C35/CX35-48C	C37-43B C37-43C	CX38-43B CX38-43C	27-1/2	699	60-1/2	1537	26-1/4	667	59-1/4	1505
---	C37-48B C37-48C	CX38-44/48B CX38-44/48C	24-1/2	622	57-1/2	1461	---	---	---	---
C35/CX35-49C	C37-49C	CX38-49C	29-1/2	749	62-1/2	1588	28-1/2	724	61-1/2	1562
C35/CX35-50/60C	C37-50/60C	CX38-50/60C	27-1/2	699	60-1/2	1537	25-7/8	657	58-7/8	1495
CX35-60C	C37-62C	CX38-62C	31-1/2	800	64-1/2	1638	30-5/8	778	63-5/8	1616

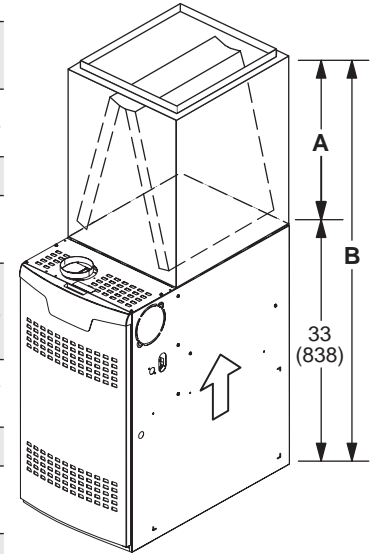

### HORIZONTAL POSITION

Model No.	A		B	
	in.	mm	in.	mm
<b>CH33</b>				
CH33-18A	21-1/2	546	54-1/2	1384
CH33-24/30A, CH33-36A, CH33-36B, CH33-36C, CH33-44/48B, CH33-50/60C,	26-1/2	673	59-1/2	1511
CH33-42B, CH33-48C				
CH33-30B, CH33-42C, CH33-48C	31-1/2	800	64-1/2	1638
<b>CH35</b>				
CH35-18A, CH35-24A, CH35-24B, CH35-30B,	26-1/2	673	59-1/2	1511
CH35-36A, CH35-36B, CH35-36C, CH35-42C, CH35-48C				
CH35-30A, CH35-42B, CH35-48B,	31-1/2	880	64-1/2	1638
CH35-51C				
<b>CHX35</b>				
CHX35-18A, CHX35-24A, CHX35-24B, CHX35-30B,	26-1/2	673	59-1/2	1511
CHX35-36A, CHX35-36B, CHX35-36C, CHX35-42C, CHX35-48C				
CHX35-30A, CHX35-42B, CHX35-48B,	31-1/2	880	64-1/2	1638
CHX35-51/61C				

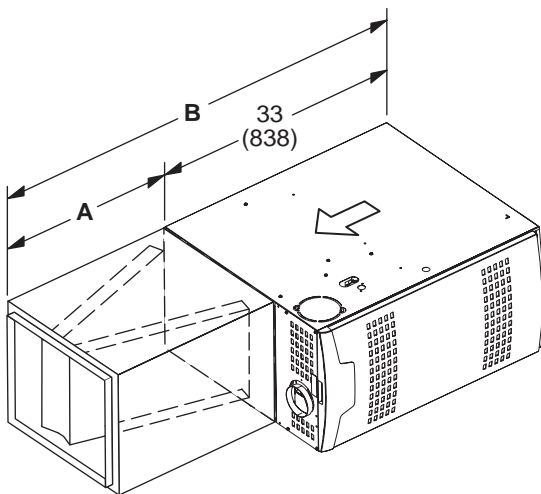

# DIMENSIONS - OPTIONAL ACCESSORIES - VENTING

## FLUSH-MOUNT VENT TERMINATION KIT 51W11 (US) or 51W12 (CANADA)

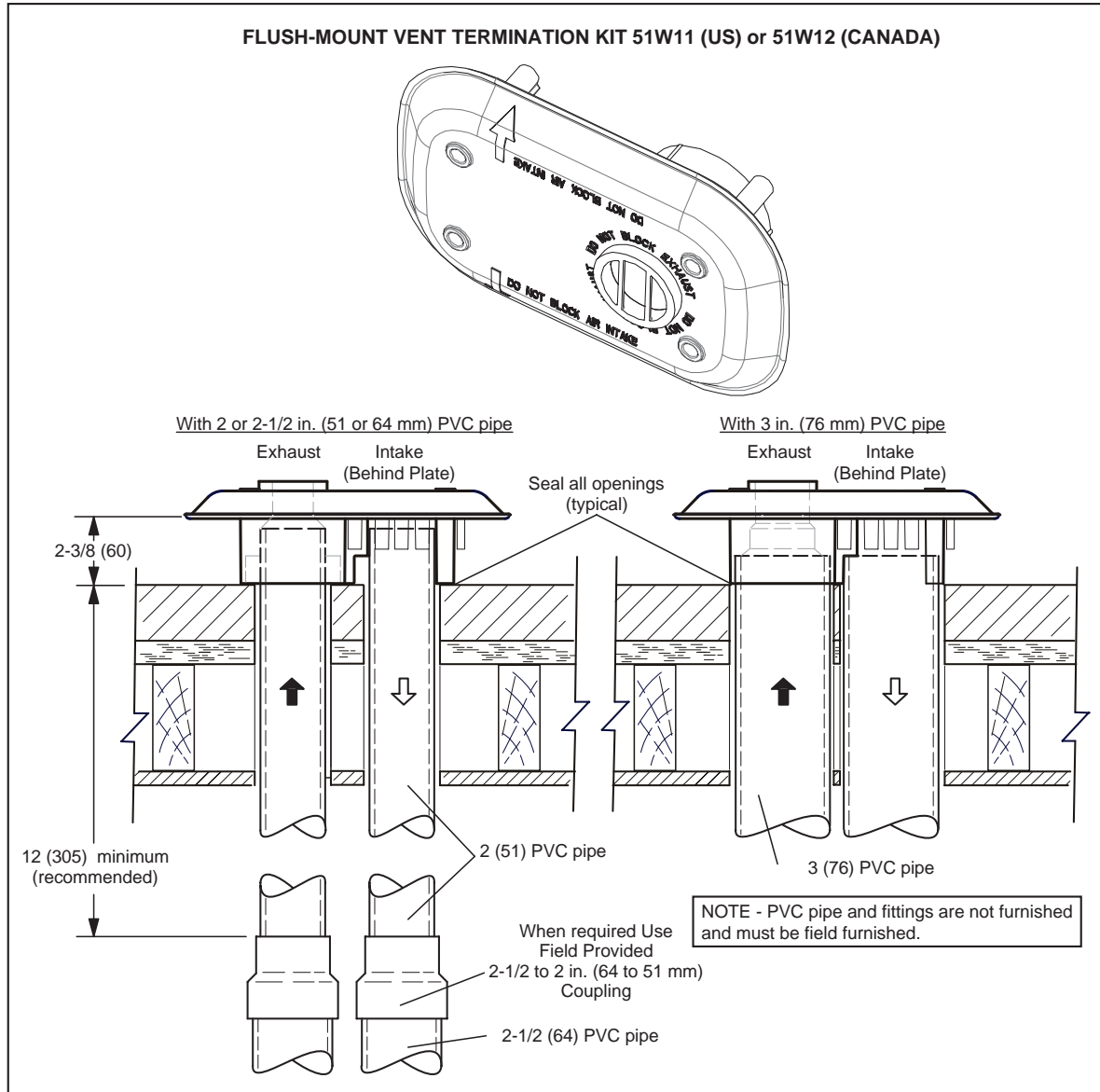

## MUFFLERS 15Y66 - 2-inch

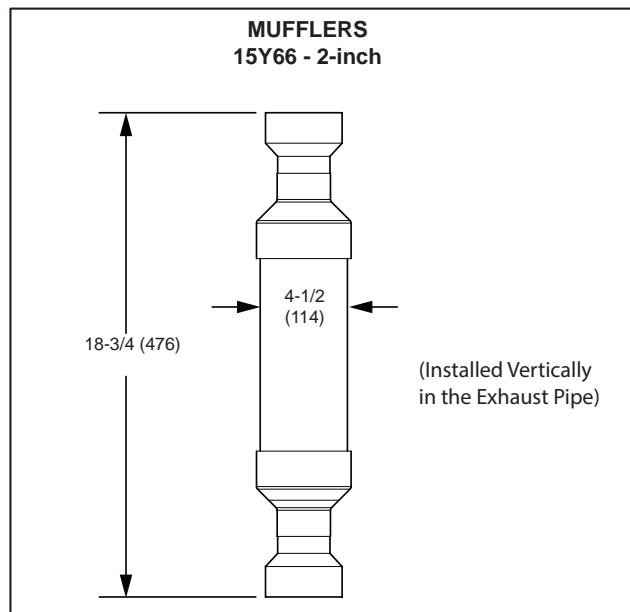

**DIMENSIONS - OPTIONAL ACCESSORIES - VENTING**

**CONCENTRIC WALL TERMINATION APPLICATIONS**

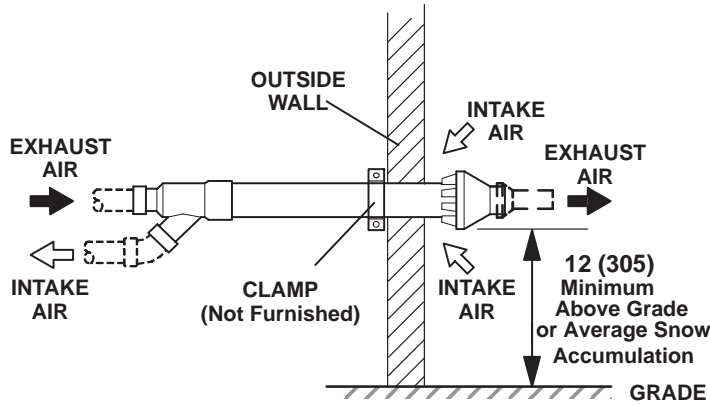

**CONCENTRIC ROOF TERMINATION APPLICATIONS**

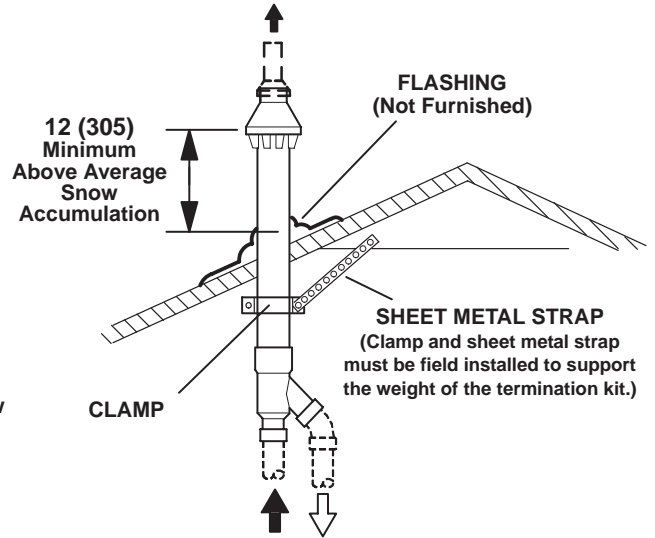

**71M80 / 69M29 / 44W92 – 2 inch kits  
60L46 / 44W93 – 3 inch kits**  
See Installation Instructions for additional information.

Note - Field provided reducer may be required to adapt different vent pipe sizes to termination.

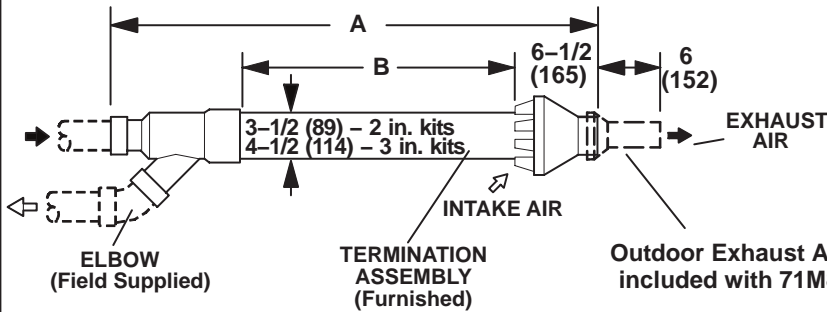

Cat. No.	A		B	
	in.	mm	in.	mm
71M80 69M29	33-3/8	848	16-3/4	425
44W92 (Canada)	29	737	15-1/2	394
60L46	38-7/8	987	21-3/16	538
44W93 (Canada)	36-1/8	918	19-1/2	495

**NOTE – Typical illustration for dimensions only. Design may vary depending on kit ordered.**

**WALL ASSEMBLY TERMINATION KIT – RING KIT 15F74 – 2 inch (51 mm)**

See Installation Instructions for additional information.

Note - Field provided reducer may be required to adapt larger vent pipe size to termination.

**DIRECT VENT APPLICATION**

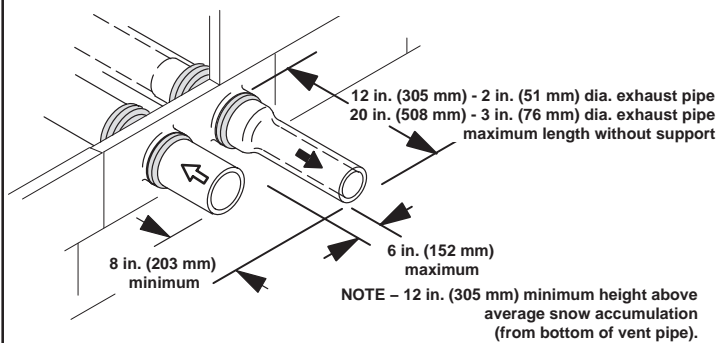

**NON-DIRECT VENT APPLICATION**

NOTE - EXHAUST PIPE SHOWN

Kit Contains Enough Parts For Two Installations

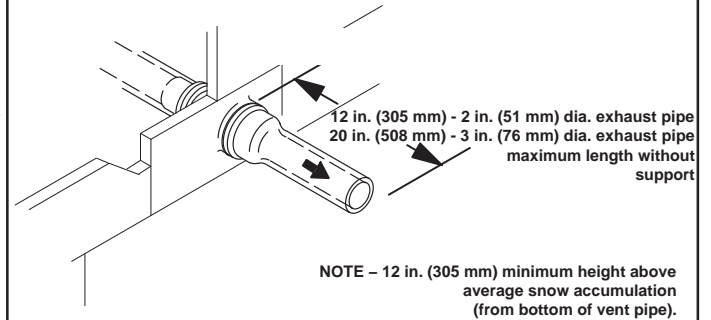

**WALL TERMINATION KITS (CLOSE-COUPLE)  
EXTENDED VENT FOR GRADE CLEARANCE**

**2 inch (51 mm) 22G44 (US)  
3 inch (76 mm) 44J40 (US)**

**See Installation Instructions for additional information.**

Note - Field provided reducer may be required to adapt different vent pipe sizes to termination.

If Intake and Exhaust Pipe is less than 12 in. (305 mm) above snow accumulation or other obstructions, field fabricated piping must be installed.

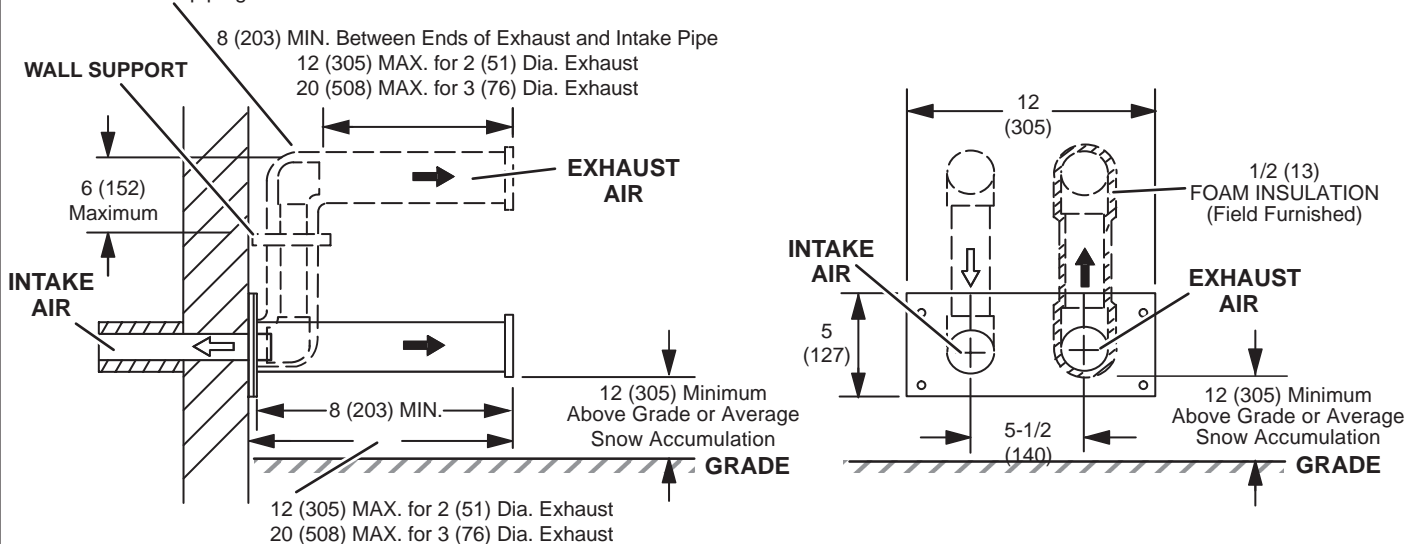

**WALL TERMINATION KITS (CLOSE-COUPLE)  
EXTENDED VENT FOR GRADE CLEARANCE**

**2 inch (51 mm) 30G28 (WTK Canada)  
3 inch (76 mm) 81J20 (WTK Canada)**

**See Installation Instructions for additional information.**

Note - Field provided reducer may be required to adapt different vent pipe sizes to termination.

If Intake and Exhaust Pipe is less than 12 in. (305 mm) above snow accumulation or other obstructions, field fabricated piping must be installed.

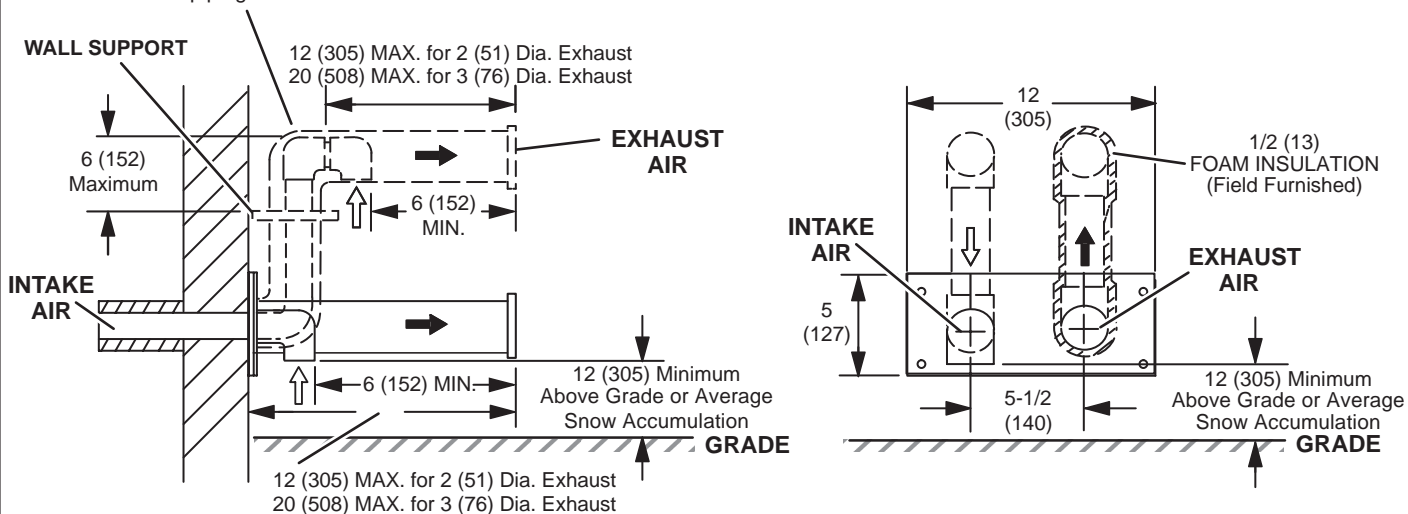









## REVISIONS

Sections	Description of Change
Blower Data	Added wire colors for different motor speeds.



Visit us at [www.lennox.com](http://www.lennox.com)

For the latest technical information, [www.LennoxPros.com](http://www.LennoxPros.com)

Contact us at 1-800-4-LENNOX

NOTE - Due to Lennox' ongoing commitment to quality, Specifications, Ratings and Dimensions subject to change without notice and without incurring liability. Improper installation, adjustment, alteration, service or maintenance can cause property damage or personal injury. Installation and service must be performed by a qualified installer and servicing agency.

©2020 Lennox Industries, Inc.