



**RESIDENTIAL  
PRODUCT SPECIFICATIONS**

Bulletin No. 210855  
April 2020  
Supersedes June 2019

**ELITE®  
SERIES**



**AFUE - 96%**  
**Input - 30,000 to 110,000 Btuh**  
**Nominal Add-on Cooling - 1.5 to 5 Tons**

**MODEL NUMBER IDENTIFICATION**

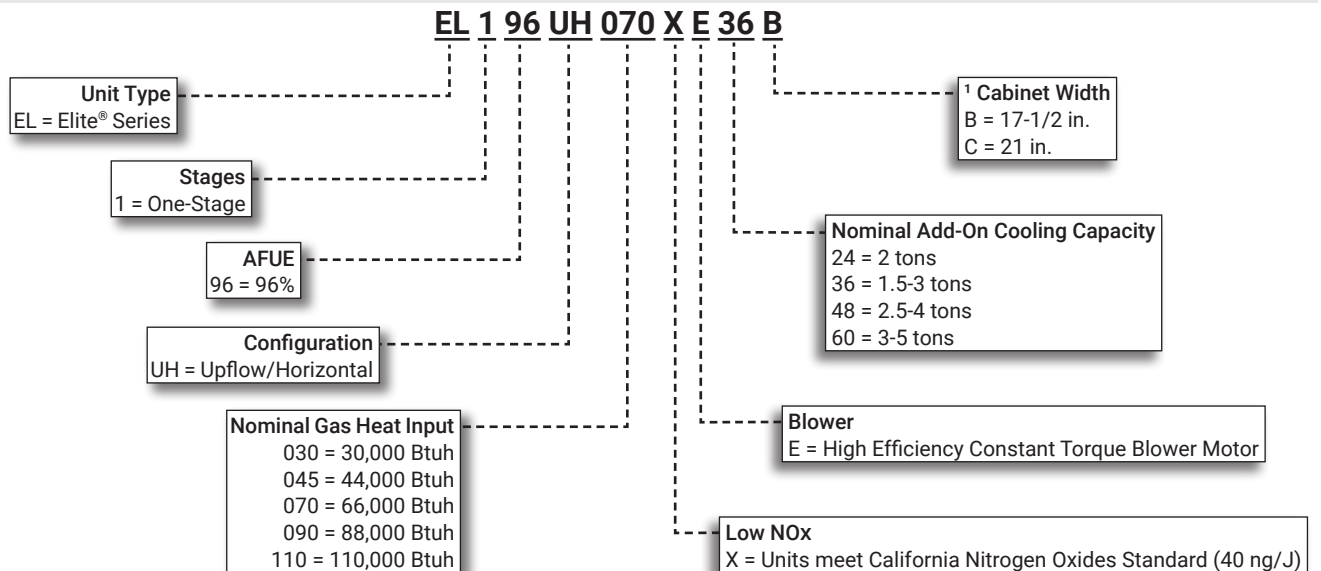

<sup>1</sup> Indoor coils with the same letter designation will physically match the furnace.

## FEATURE HIGHLIGHTS

1. Lennox Duralok Plus™ Heat Exchanger
2. Secondary Heat Exchanger
3. Inshot Burners
4. SureLight® Hot Surface Ignitor
5. Gas Control Valve
6. Combustion Air Inducer
7. Flame Rollout Switches
8. SureLight® Integrated Furnace Control
9. Power Saver™ Constant Torque Blower Motor
10. Insulated Cabinet
11. Safety Interlock Switch
12. Gas Piping And Electrical Inlets

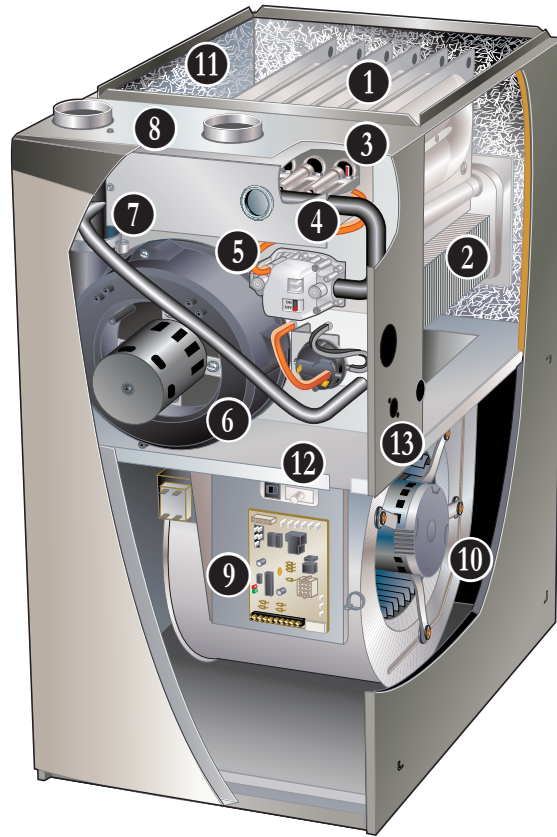

## CONTENTS

Approvals and Warranty . . . . .	3
Blower Data . . . . .	13
Dimensions - Furnace/Coil Combined Dimensions . . . . .	18
Dimensions - Horizontal Position . . . . .	16
Dimensions - Optional Accessories . . . . .	17
Dimensions - Optional Accessories - Venting . . . . .	19
Dimensions - Upflow Position . . . . .	15
Features . . . . .	3
Gas Heat Accessories . . . . .	10
High Altitude Derate . . . . .	11
Installation Clearances . . . . .	8
Optional Accessories - Order Separately . . . . .	10
Specifications . . . . .	9
Vent Lengths . . . . .	12

## APPROVALS AND WARRANTY

### APPROVALS

- AHRI Certified
- CSA International Certified
- Tested and rated according to US DOE test procedures and FTC labeling regulations
- Approved by the California Energy Commission and meets California Nitrogen Oxides Standard (NO<sub>x</sub>) limits of 40 ng/J
- Units are approved for installations from 0 - 4500 ft.
- ENERGY STAR® certified units are designed to use less energy, help save money on utility bills, and help protect the environment
- ISO 9001 Registered Manufacturing Quality System
- Blower data from unit tests conducted in Lennox Laboratory air test chamber

### California Only

- If installed in South Coast Air Quality Management District (SCAQMD) only:
  - This furnace does not meet the SCAQMD Rule 1111 NO<sub>x</sub> emission limit (14 ng/J), and thus is subject to a mitigation fee of up to \$450. This furnace is not eligible for the Clean Air Furnace Rebate Program: [www.CleanAirFurnaceRebate.com](http://www.CleanAirFurnaceRebate.com).
- If installed in San Joaquin Valley Air Pollution Control District (SJVAPCD) only:
  - This furnace does not meet the SJVAPCD Rule 4905 NO<sub>x</sub> emission limit (14 ng/J), and thus is subject to a mitigation fee of up to \$450

### WARRANTY

- Duralok Plus™ Aluminized Steel Heat Exchanger:
  - Limited lifetime (twenty year transferable) in residential applications
  - Limited ten years in non-residential applications
- All other covered components:
  - Limited five years in residential installations
  - Limited one year in non-residential installations

**NOTE** - Refer to Lennox Equipment Limited Warranty certificate included with unit for specific details.

## FEATURES

### APPLICATIONS

- Input capacities of 30,000, 44,000, 66,000, 88,000, and 110,000 Btuh
- Energy efficiency (AFUE) - 96%
- Compact cabinet for upflow, horizontal-left or horizontal-right applications without any modifications
- Removable bottom seal panel shipped in place for side return air is easily removed for bottom/end return air applications
- Lennox add-on indoor coils, high-efficiency air cleaners and humidifiers can easily be added to furnace
- Shipped factory assembled with all controls installed and wired
- Factory test operated to ensure proper operation

### HEATING SYSTEM

- 1 **Lennox Duralok Plus™ Heat Exchanger Assembly**
  - Lennox developed heat exchanger assembly consists of primary heat exchanger and secondary condenser coil assembly
  - Main multi-pass crimped seam design clamshell type
  - Constructed of heavy-gauge, aluminized steel
  - Designed for normal expansion and contraction with maximum efficiency and minimum resistance to air flow

- 2
  - Secondary heat exchanger condenser coil constructed of aluminum fins fitted to stainless steel tubes
  - Coil is factory tested for leaks
  - Condensate drain header box assembly located on front of coil
  - Compact size permits low overall design of furnace cabinet
  - Laboratory life cycle tested in excess of industry standards

### Lennox Designed Header Box

- Header box on end of condenser coil collects flue condensate for disposal through condensate drains
- Drains are located on each side of the cabinet for easy field installation of condensate drain trap
- Only one drain is used, the other drain is sealed
- Condensate drain trap is included with the unit for field installation

## FEATURES

### HEATING SYSTEM (continued)

#### Lennox Designed Flue Condensate Trap Assembly

- Field installed outside the conditioned air stream
- Assembly can be mounted on either side of cabinet in upflow applications
- Assembly is mounted below the cabinet in horizontal applications
- Can also be mounted remotely (up to 5 ft. away) from unit
- See installation instructions
- 90° street elbow furnished for ease of drain trap installation
- Drain connection can be made with field provided PVC pipe or PVC coupling
- Drain cap on trap allows easy cleaning and winterizing

#### 3 Inshot Burners

- Aluminized steel inshot burners provide efficient, trouble-free operation
- Burner venturi mixes air and gas in correct proportion for proper combustion
- Burner assembly can be removed from the unit as a single component for ease of service

#### 4 SureLight® Hot Surface Ignitor

- Tough, reliable, long-life, trouble-free performance
- Silicon nitride ignitor
- Cemented to steatite block for protection against current leakage
- Ignition leads are constructed of nickel plated copper and are enclosed in high temperature Teflon® insulation for dependable operation

#### 5 Gas Control Valve

- 24 volt redundant combination gas control valve combines manual shut off switch (On-Off), automatic electric valve (dual) and gas pressure regulation into a compact combination control

#### 6 Combustion Air Inducer

- Shaded pole heavy duty blower prepurges heat exchanger and safely vents flue products
- Operates only during heating cycle
- Pressure switch proves combustion air inducer operation before allowing gas valve to open

#### 7 Flame Rollout Switches (2)

- Factory installed on burner box
- Switch provides protection from abnormal operating conditions
- Manual reset

#### Limit Control

- Primary limit is accurately located on vestibule panel
- Automatic reset

### Optional Accessories

#### High Altitude Orifice Kits

- Required on all units for proper unit operation at altitudes from 7501 to 10,000 ft.
- Available for natural gas and LPG/propane

#### High Altitude Pressure Switch Kit

- Required for proper unit operation on installations above 4500 ft.

#### Natural Gas to LPG/Propane Conversion Kit

- Required for field changeover from natural gas to LPG/Propane

#### LPG/Propane to Natural Gas Conversion Kit

- Required for field changeover from LPG/Propane to natural gas

#### Muffler (US Only)

- Significantly reduces outdoor operating sound levels
- Two-inch diameter muffler is optional for 030 through 110 input models

**NOTE** - Two-inch muffler is optional for the 110 input model with a maximum vent pipe length of up to 29 ft.

- Three-inch diameter muffler is optional for 110 and 135 input models

**NOTE** - Three-inch muffler is optional for the 110 input model with a minimum vent pipe length of 30 ft.

- Installed vertically in the exhaust piping
- See Optional Accessory Dimension Drawing

### **DIRECT VENT / NON-DIRECT VENT SEALED COMBUSTION SYSTEM**

- 8 • Furnace features a “sealed combustion” system and can be installed in either Direct Vent or Non-Direct applications

- In Direct Vent applications, combustion air is supplied from outdoors and flue gases are discharged outdoors

- In Non-Direct Vent applications, combustion air is supplied from indoors and flue gases are discharged outdoors

**NOTE** - Lennox has approved the use of DuraVent® PolyPro® and Centrotherm InnoFlue® manufactured vent pipe and terminations as an alternative to PVC vent pipe. Must be ordered separately.

- Tested and listed to the ULC S636 standard in Canada

## FEATURES

### **DIRECT VENT / NON-DIRECT VENT SEALED COMBUSTION SYSTEM (continued)**

- The polypropylene venting system must follow the uninsulated and unconditioned space vent lengths listed in the table on Page 12
- Refer to the Installation Instructions for additional details

#### **Flue Coupling**

- Assists with exhaust flue piping connection and servicing
- Includes flexible one 2 inch rubber coupling and two adjustable bands
- Approved for all Lennox 90% furnaces

#### **Termination Kits**

- Facilitates installation of combustion air intake pipe and flue exhaust pipe
- Refer to venting table in this bulletin to determine pipe size needed and proper termination kit required
- Certain Termination Kits are certified to ULC S636 standard for use in Canada only
- See Optional Accessories table and dimension drawings

#### **Concentric - Direct Vent Applications**

- 2 or 3 inch kit contains concentric termination assembly, reducer bushing and 45 degree elbow
- 2 inch kit for -045-070 models contains an outdoor exhaust accelerator
- Kit requires single hole penetration of roof or wall for installation
- Roof Termination Flashing Kit is available for use with 2 inch Kits
- CSA certified

#### **Flush-Mount**

- Kit contains flush-mount termination, accelerator, mounting template and hardware
- Kit may be used with 2, 2-1/2 or 3 in. pipe

#### **Wall Assembly**

##### **Close Couple (US Only) - Direct Vent Applications**

- 2 or 3 inch kit consists of close-couple, side-by-side PVC piping with galvanized steel wall cover plate for sealing and isolating piping penetration of the wall
- Piping spacing and length is sized for proper wall installations
- CSA certified

##### **Close Couple WTK (Canada Only) - Direct Vent Applications**

- 2 or 3 inch kit contains one insulated faceplate, one insulated exhaust pipe, elbow and fittings. Certified to ULC S636 standard

##### **Wall Ring - Direct Vent or Non-Direct Vent Applications**

- 2 inch kit contains 2 stainless steel outside seal caps, 2 galvanized steel inside seal caps, 4 seal rings for the caps and 18 inch insulation sleeve for sealing and isolating intake and exhaust piping penetration of wall

**NOTE** - Maintain a maximum of 6 inches between the inlet and outlet openings in the installation of the pipes.

#### **Roof Termination Flashing Kit**

- For vertical venting through a roof
- 3 inch kit contains two neoprene rubber roof flashings
- Vent pipe and insulation not furnished
- Flashing Kit can also be used with 2 inch Concentric Vent Termination Kits used in vertical venting rooftop applications

## **CONTROLS**

### **9 SureLight® Integrated Furnace Control**

- Contains all necessary controls and relays to operate furnace
- Combustion air inducer is operated by the integrated furnace control. Prior to ignition, a pre-purge cycle for 15 seconds is initiated
- After the main burners are turned off, a post-purge cycle for 5 seconds is run
- Flame sensor assures safe and reliable operation
- Should loss of flame occur, the integrated furnace control will initiate 4 re-attempts at ignition before locking out unit operation for 60 minutes
- Watchguard type circuit automatically resets ignition controls after one hour of continuous thermostat demand after unit lockout, eliminating nuisance calls for service
- Fan control consists of adjustable blower timed-off delay (60, 90, 120, 180 seconds - factory setting 90 seconds) and fixed blower timed-on delay (30 seconds heating, 2 seconds cooling)
- For air-conditioning applications, blower is automatically energized on thermostat demand for cooling
- Two accessory terminals furnished for additional power supply requirements for 120 volt (less than 1 amp) power humidifiers and powered air cleaners
- One additional terminal is furnished for power supply requirements for 24V (less than 0.5 amp) low voltage accessories
- Ignition control has a single red LED to indicate status and as an aid in troubleshooting
- Last ten codes are stored in non-volatile memory (accessible by recall button on control) for servicing

#### **24 Volt Transformer**

- Furnished and factory installed in control box
- \40VA transformer has circuit breaker wired in series

#### **Field Wiring Make-Up Box**

- Furnished for line voltage wiring
- Factory installed internally on left side of furnace
- May be installed internally or externally on either side of furnace

## FEATURES

### CONTROLS (continued)

#### Optional Accessories

##### Blower Relay Kit

##### (For Use With Two-Stage Outdoor Units)

- Allows furnace blower speed changes when matched with two-stage air conditioners or heat pumps

##### iComfort® E30 Smart Wi-Fi Thermostat

- Wi-Fi enabled, electronic 7-day, universal, multi-stage, programmable, touchscreen thermostat
- 3 Heat/2 Cool
- Auto-changeover
- Controls dehumidification during cooling mode and humidification during heating mode
- Offers enhanced capabilities including humidification / dehumidification / dewpoint measurement and control, Humiditrol® control, and equipment maintenance reminders
- Easy to read 7 in. color touchscreen (measured diagonally)
- LCD display with backlight shows the current and set temperature, time, inside relative humidity, system status (operating mode and schedules) and outside temperature (optional outdoor sensor required)
- Smooth Setback Recovery starts system early to achieve setpoint at start of program period
- Compressor short-cycle protection (5 minutes)
- Up to four separate schedules are available plus Schedule IQ™
- One-Touch Away Mode - A quick and easy way to set the cooling and heating setpoints while away
- Smart Away™ - Uses geo-fencing technology to determine when the homeowner is within a predetermined distance from the home to operate the system when leaving, away and arriving
- Wi-Fi remote monitoring and adjustment through a home wireless network for desktop PCs, laptops and apps for smartphones or tablets
- Smart home automation compatible with Apple HomeKit™, Amazon Alexa®, Google Assistant and IFTTT
- High Definition Color Display, Mag-Mount, Smart Hub Controller, wallplate (for retrofit installations) furnished for easy installation
- See the iComfort® E30 Smart Wi-Fi Thermostat Product Specifications bulletin for more information



##### Remote Outdoor Temperature Sensor

- Used with the iComfort® Communicating thermostats and the iComfort® E30 Smart Thermostat
- When installed outdoors, sensor allows thermostat to display outdoor temperature



**NOTE** - Sensor is required for Enhanced Dehumidification Control (EDA) applications.

**NOTE** - The outdoor sensor is furnished as standard with iComfort® Communicating outdoor units, optional for conventional units.

##### Thermostat

- Thermostat is not furnished with unit
- See Lennox Price Book for selection

##### Furnace Twinning Kit

- Required to operate two furnaces simultaneously
- Kit consists of twinning relays, quick connect terminals and mounting hardware
- Used for single-stage heating/single-stage cooling with a single-stage thermostat

##### Night Service Kit

- Contains most commonly used service parts:
  - Furnace Control
  - Igniter
  - Flame Sensor
  - Gas Valve
  - Transformer
  - Service Manual

##### BLOWER

- Direct drive blower
- Statically and dynamically balanced
- Resiliently mounted
- Blower assembly easily removed for servicing

##### 10 Power Saver™ Constant Torque Blower Motor

- DC Brushless Motor
- High Efficiency Constant Torque
- ECM (Electronically Commutated Motor)
- Motor is programmed to provide constant torque at each of the selectable speeds
- Motor is controlled by the Integrated Furnace Control
- Blower speeds are easily changed on the integrated furnace control
- See Blower Data tables

## FEATURES

### CABINET

- Low-profile, narrow width allows easy installation
- Heavy-gauge, cold rolled steel construction
- Pre-painted finish
- Flanges provided on supply air opening for ease of plenum connection or alignment with indoor coil
- 11 • Insulated with foil faced insulation on sides and back of heating compartment and mat faced insulation in blower compartment
- Sealed blower compartment
- Inner blower compartment access panel seals blower compartment from air leakage
- Cabinet door can be removed without any tools
- Complete service access
- 12 • Safety interlock switch automatically shuts off power to unit when blower compartment access door is removed
- 13 • Gas piping and electrical inlets are provided in both sides of cabinet

#### Bottom/Side Return Air Entry:

- Upflow/horizontal with bottom return air entry:
  - Remove furnished bottom seal panel from cabinet
- Upflow only with side return-air entry:
  - Corners are marked on either side of cabinet for return air cut-out
- See dimension drawings

**NOTE** - 60C size units that require air volumes over 1800 cfm must have one of the following:

1. Single side return air and Optional Return Air Base with transition that must accommodate required 20 x 25 x 1 inch air filter to maintain proper velocity
  2. Bottom return air
  3. Return air from both sides
  4. Bottom and one side return air
- See Blower Performance Tables for additional information

#### Coil Match-Up

- All furnaces exactly match Lennox cased upflow indoor coils and horizontal indoor coils with same letter designation (A, B, C, D) in model number
- No adaptor required
- Engaging holes furnished on cabinet for alignment
- Lennox uncased coils match furnaces without any overhang but require an optional adaptor base or field fabricated transition to match furnace opening
- See coil bulletin for additional information

#### Low Leakage Cabinet

- All models have less than 2% air leakage
- Meets ANSI/ASHRAE Standard 193-2010 "Method of Test for Determining the Air Tightness of HVAC Equipment"

### Optional Accessories

#### Condensate Drain Heat Cable Kits

- Self-limiting wattage heat cable prevents condensate drain from freezing in unconditioned areas
- Available in 6 or 24 ft. lengths

#### Horizontal Suspension Kit

- Provides suspension of unit and indoor coil in horizontal applications
- Allows complete service access
- Consists of corner mounted hanging brackets with vibration isolators, return air end support rail and hardware for assembly
- Metal hanging straps must be field provided

#### Crawl Space Vent Drain Kit

- Allows venting through a crawl space for upflow and horizontal applications
- Kit for Canada is certified to ULC S636
- Includes 2 or 3 inch sanitary tee, 2 inch PVC assembly, PVC boot and clamp

#### Return Air Base

**NOTE** - On furnaces with side return air and condensate trap on the same side of the cabinet, a field fabricated transition or Return Air Base is required when using an IAQ product higher than 14-3/16 inches installed next to the unit and serviced from the front. IAQ products higher than 20 inches require a field fabricated transition.

**NOTE** - Must be used for 60C and 60D size models with air volumes over 1800 cfm in upflow applications when only one side return is required.

- Cabinet is shipped flat for easy field assembly
- Pre-painted steel to match the furnace
- See Dimension Drawing

#### High Performance Economizer (Commercial Applications Only)

- Designed for applications requiring outdoor air to be utilized in a commercial HVAC system
- Allows the entry of fresh outdoor air for free cooling, reducing the requirement for mechanical cooling
- Heavy gauge galvanized steel cabinet lined with thick fiberglass insulation
- Mixed air sensor, outdoor air sensor and 24VAC transformer furnished
- Approved for California Title 24 building standards. ASHRAE 90.1-2010 compliant
- See separate Product Specifications bulletin for additional information and available control and sensor options

## FEATURES

### **FILTER (not furnished)**

- Filter and provisions for external mounting must be field provided

### **Optional Accessories**

#### **Air Filter and Rack Kit for Horizontal Return Air (End)**

##### **Applications**

- Washable or vacuum cleanable polyurethane frame type filter and external end return air rack available for field installation
- Rack has filter door for easy filter servicing
- Flanges on rack allow easy duct connection
- See Dimension Drawing

#### **Air Filter and Rack Kit for Upflow Side Return Air**

##### **NOTE** - Not for use with Return Air Base

- Washable or vacuum cleanable polyurethane frame type filter and external side return air rack available for field installation
- Available in single and ten pack kits
- Rack has filter door for easy filter servicing
- Flanges on rack allow easy duct connection
- Field installs on either side of unit cabinet
- See Dimension Drawing

## INSTALLATION CLEARANCES

Sides	<sup>1</sup> 0 inches (0 mm)
Rear	0 inches (0 mm)
Top/Plenum	1 inch (25 mm)
Front	0 inches (0 mm)
Front (service/alcove)	24 inches (610 mm)
Floor	<sup>2</sup> Combustible

NOTE – Air for combustion must conform to the methods outlined in the National Fuel Gas Code (NFPA 54/ANSI-Z223.1) or the National Standard of Canada CAN/CSA-B149.1 Natural Gas and Propane Installation Code\*.

NOTE – In the U.S. flue sizing must conform to the methods outlined in the current National Fuel Gas Code (NFPA 54/ANSI-Z223.1) or applicable provisions of local building codes. In Canada flue sizing must conform to the methods outlined in National Standard of Canada CAN/CSA-B149.1.

<sup>1</sup> Allow proper clearances to accommodate condensate trap and vent pipe installation.

<sup>2</sup> Do not install the furnace directly on carpeting, tile, or other combustible materials other than wood flooring.



## SPECIFICATIONS

Gas Heating Performance		Model No.	EL196UH030XE24B	EL196UH045XE24B	EL196UH045XE36B
		AHRI Ref. No.	201849567	201849568	201849569
		<sup>1</sup> AFUE	96%	96%	96%
		Input - Btuh	30,000	44,000	44,000
		Output - Btuh	28,800	42,800	42,800
		Temperature rise range - °F	30 - 60	40 - 70	35 - 65
		Gas Manifold Pressure (in. w.g.) Nat. Gas / LPG/Propane	3.5 / 10	3.5 / 10	3.5 / 10
		High static - in. w.g.	0.5	0.5	0.5
<b>Energy Star® Certified</b>			Yes	Yes	Yes
<b>Connections in.</b>	Intake / Exhaust Pipe (PVC)		2 / 2	2 / 2	2 / 2
	Gas pipe size IPS		1/2	1/2	1/2
	Condensate Drain Trap (PVC pipe) - i.d.		3/4	3/4	3/4
	with furnished 90° street elbow with field supplied (PVC coupling) - o.d.		3/4 slip x 3/4 Mipt 3/4 slip x 3/4 MPT	3/4 slip x 3/4 Mipt 3/4 slip x 3/4 MPT	3/4 slip x 3/4 Mipt 3/4 slip x 3/4 MPT
<b>Indoor Blower</b>	Wheel nom. dia. x width - in.		10 x 8	10 x 8	10 x 8
	Motor Type		DC Brushless	DC Brushless	DC Brushless
	Motor output - hp		1/2	1/2	1/2
	Tons of add-on cooling		1 - 2	1 - 2	1.5 - 3
	Air Volume Range - cfm		260 - 990	260 - 990	520 - 1345
<b>Electrical Data</b>	Voltage		120 volts - 60 hertz - 1 phase		
	Blower motor full load amps		6.8	6.8	6.8
	Maximum overcurrent protection		15	15	15
<b>Shipping Data</b>	lbs. - 1 package		129	129	129

NOTE - Filters and provisions for mounting are not furnished and must be field provided.

<sup>1</sup> Annual Fuel Utilization Efficiency based on DOE test procedures and according to FTC labeling regulations. Isolated combustion system rating for non-weatherized furnaces.

## SPECIFICATIONS

Gas Heating Performance		Model No.	EL196UH070XE36B	EL196UH090XE48C	EL196UH110XE60C
		AHRI Ref. No.	201849570	201849571	201849572
		<sup>1</sup> AFUE	96%	96%	96%
		Input - Btuh	66,000	88,000	110,000
		Output - Btuh	63,900	85,600	107,200
		Temperature rise range - °F	35 - 65	50 - 80	45 - 75
		Gas Manifold Pressure (in. w.g.) Nat. Gas / LPG/Propane	3.5 / 10	3.5 / 10	3.5 / 10
		High static - in. w.g.	0.5	0.5	0.5
<b>Energy Star® Certified</b>			Yes	Yes	Yes
<b>Connections in.</b>	Intake / Exhaust Pipe (PVC)		2 / 2	2 / 2	2 / 2
	Gas pipe size IPS		1/2	1/2	1/2
	Condensate Drain Trap (PVC pipe) - i.d.		3/4	3/4	3/4
	with furnished 90° street elbow with field supplied (PVC coupling) - o.d.		3/4 slip x 3/4 Mipt 3/4 slip x 3/4 MPT	3/4 slip x 3/4 Mipt 3/4 slip x 3/4 MPT	3/4 slip x 3/4 Mipt 3/4 slip x 3/4 MPT
<b>Indoor Blower</b>	Wheel nom. dia. x width - in.		10 x 8	10 x 10	11-1/2 x 10
	Motor Type		DC Brushless	DC Brushless	DC Brushless
	Motor output - hp		1/2	3/4	1
	Tons of add-on cooling		1.5 - 3	2.5 - 4	3 - 5
	Air Volume Range - cfm		550 - 1380	760 - 1740	1055 - 2220
<b>Electrical Data</b>	Voltage		120 volts - 60 hertz - 1 phase		
	Blower motor full load amps		6.8	8.4	10.9
	Maximum overcurrent protection		15	15	15
<b>Shipping Data</b>	lbs. - 1 package		134	158	170

NOTE - Filters and provisions for mounting are not furnished and must be field provided.

<sup>1</sup> Annual Fuel Utilization Efficiency based on DOE test procedures and according to FTC labeling regulations. Isolated combustion system rating for non-weatherized furnaces.

## OPTIONAL ACCESSORIES - ORDER SEPARATELY

			"B" Width Models	"C" Width Models	
<b>CABINET ACCESSORIES</b>					
Horizontal Suspension Kit - Horizontal only			51W10	51W10	
Return Air Base - Upflow only			50W98	50W99	
High Performance Economizer (Commercial Only)			10U53	10U53	
<b>CONDENSATE DRAIN KITS</b>					
Condensate Drain Heat Cable	6 ft.		26K68	26K68	
	24 ft.		26K69	26K69	
Crawl Space Vent Drain Kit	US		51W18	51W18	
	Canada		15Z70	15Z70	
<b>CONTROLS</b>					
Blower Relay Kit (for two-stage outdoor units)			85W66	85W66	
Furnace Twinning Kit			16W72	16W72	
iComfort® E30 Smart Thermostat			15S63	15S63	
Remote Outdoor Temperature Sensor			X2658	X2658	
Night Service Kit			84W48	84W48	
<b>FILTER KITS</b>					
1 Air Filter and Rack Kit	Horizontal (end)	Size of filter - in.	87L96 - 18 x 25 x 1	87L97 - 20 x 25 x 1	
		Side Return	Single	44J22	44J22
			Ten Pack	66K63	66K63
			Size of filter - in.	16 x 25 x 1	16 x 25 x 1

## TERMINATION KITS

See Installation Instructions for specific venting information.

Termination Kits - Direct Vent Applications Only	Concentric	US - 2 in.	71M80	69M29
		3 in.	- - -	60L46
		Canada - 2 in.	44W92	44W92
		3 in.	- - -	44W93
	Flush-Mount	US - 2, 2-1/2 or 3 in.	51W11	51W11
		Canada - 2, 2-1/2 or 3 in.	51W12	51W12
Wall - Close Couple	US - 2 in.	22G44	- - -	
	3 in.	44J40	44J40	
Wall - Close Couple WTK	Canada - 2 in.	30G28	- - -	
	3 in.	81J20	81J20	
Termination Kits - Direct or Non-Direct Vent	Roof	2 in.	15F75	15F75
	Wall Ring Kit	2 in.	15F74	<sup>3</sup> 15F74
Roof Termination Flashing Kit - Direct or Non-Direct Vent (2 flashings)		3 in.	44J41	44J41

## VENTING

Flue Coupling	2 in.	17H92	17H92
---------------	-------	-------	-------

<sup>1</sup> Cleanable polyurethane frame type filter.

<sup>2</sup> Kits contain enough parts for two, non-direct vent installations.

<sup>3</sup> Non-direct vent only.

NOTE - Termination Kits (44W92, 44W93, 30G28, 51W12, 51W19, 81J20) and Crawl Space Vent Drain Kit (15Z70) are certified to ULC S636 standard for use in Canada only.

## GAS HEAT ACCESSORIES

Input	High Altitude Pressure Switch Kit		Natural Gas to LPG/Propane Kit	LPG/Propane to Natural Gas Kit	Natural Gas High Altitude Orifice Kit	LPG/Propane High Altitude Orifice Kit	Muffler (US Only)
	4501 - 7500 ft.	7501 - 10,000 ft.	0 - 7500 ft.	0 - 7500 ft.	7501 - 10,000 ft.	7501 - 10,000 ft.	
030	No Change	11U65	17H63	N/A	14C90	17H66	15Y66 (2-inch)
045	No Change	11U65	11K49	73W81	73W37	11K44	15Y66 (2-inch)
070	11U71	11U67	11K49	73W81	73W37	11K44	15Y66 (2-inch)
090	11U70	11U64	11K49	73W81	73W37	11K44	15Y66 (2-inch)
110	11U71	11U64	11K49	73W81	73W37	11K44	<sup>1</sup> 15Y66 (2-inch) 16A56 (3-inch)

<sup>1</sup> Two-inch diameter muffler (15Y66) is optional for 110 input model with a maximum vent pipe length of up to 29 ft.

Three-inch diameter muffler (16A56) is optional for 110 input model with a minimum vent pipe length of 30 ft.

## HIGH ALTITUDE DERATE

NOTE - Units may be installed at altitudes up to 10,000 ft.

At altitudes above 4501 ft. the unit must be derated to match the manifold pressure information shown below.

Units installed at altitudes of 4501 to 10,000 ft. require a pressure switch change.

Units installed at altitudes of 7501 to 10,000 ft. require an orifice change.

See the Gas Heat Accessories table for ordering information.

NOTE - This is the only permissible derate for these units.

NOTE - In Canada, certification for installations at elevations over 4500 feet is the jurisdiction of local authorities.

Input	Gas	Manifold Pressure in. w.g.					Supply Line Pressure in. w.g.	
		0 - 4500 ft.	4501 - 5500 ft.	5501 - 6500 ft.	6501 - 7500 ft.	7501 - 10,000 ft.	0 - 10,000 ft.	
							Min.	Max.
All Sizes	Natural	3.5	3.3	3.2	3.1	3.5	4.5	13.0
	LPG/Propane	10.0	9.4	9.1	8.9	10.0	11.0	13.0

## OUTDOOR TERMINATION KIT USAGE

Input Size	Vent Pipe Diameter (in.)	Standard Terminations				Concentric Terminations			
		Flush Mount Kit	Wall Kit		Wall Ring Kit	Field Fabricated Exhaust Accelerator Size Required	Concentric Kit		
			2 inch	3 inch	2 inch		1-1/2 inch	2 inch	3 inch
			51W11 (US) 5 51W12 (CA)	22G44 (US) 5 30G28 (CA)	44J40 (US) 5 81J20 (CA)		15F74	71M80 (US) 5 44W92 (CA)	69M29 (US) 5 44W92 (CA)
030/ 045	1 1-1/2	4 YES	YES	2 YES	2 YES	1-1/2 in.	3 YES	---	---
	2	4 YES	YES	2 YES	2 YES	1-1/2 in.	3 YES	---	---
	2-1/2	4 YES	YES	2 YES	2 YES	1-1/2 in.	3 YES	---	---
	3	4 YES	YES	2 YES	2 YES	1-1/2 in.	3 YES	---	---
070	1 1-1/2	4 YES	YES	2 YES	2 YES	1-1/2 in.	3 YES	---	---
	2	4 YES	YES	2 YES	2 YES	1-1/2 in.	3 YES	---	---
	2-1/2	4 YES	YES	2 YES	2 YES	1-1/2 in.	3 YES	---	---
	3	4 YES	YES	2 YES	2 YES	1-1/2 in.	3 YES	---	---
090	2	4 YES	---	YES	YES	2 in.	---	YES	YES
	2-1/2	4 YES	---	YES	YES	2 in.	---	YES	YES
	3	4 YES	---	YES	YES	2 in.	---	YES	YES
110	2	YES	---	YES	YES	2 in.	---	YES	YES
	2-1/2	YES	---	YES	---	2 in.	---	YES	YES
	3	YES	---	YES	---	2 in.	---	YES	YES

NOTE - Standard Terminations do not include any vent pipe or elbows external to the structure.

Any vent pipe or elbows external to the structure must be included in total vent length calculations. See Vent Length Tables.

<sup>1</sup> 2 inch to 1-1/2 inch reducer required, must be field provided.

<sup>2</sup> Requires field provided 1-1/2 in. outdoor exhaust accelerator.

<sup>3</sup> Concentric Kits 71M80 and 44W92 include 1-1/2 in. outdoor exhaust accelerator, required when used with 030, 045 and 070 input models. Accelerator is not used with 090 or 110 input models. When using 1-1/2 in. piping, the pipe must be transitioned to 2 in. pipe when used with the Concentric Kit.

<sup>4</sup> Flush Mount Kit 51W11 and 51W12 includes 1-1/2 in. outdoor exhaust accelerator, required when used with 030, 045, 070 and 090 input models. Accelerator is not used with 110 input models. When using 1-1/2 in. piping, the pipe must be transitioned to 2 in. pipe when used with the Flush Mount Kit.

<sup>5</sup> Termination Kits 30G28, 44W92, 44W93, 51W12 and 81J20 are certified to ULC S636 standard for use in Canada only.

## VENT LENGTHS

### STANDARD TERMINATION AT ELEVATION 0 - 10,000 ft.

Pipe Size Input	1-1/2 in.					2 in.				2-1/2 in.				3 in.				
	030	045	070	090	110	030/ 045	070	090	110	030/ 045	070	090	110	030/ 045	070	090	110	
No. of 90 ELL	1	25	20	15	N/A	N/A	81	66	44	24	115	100	68	43	137	137	118	118
	2	20	15	10	N/A	N/A	76	61	39	19	110	95	63	38	132	132	113	113
	3	15	10	N/A	N/A	N/A	71	56	34	14	105	90	58	33	127	127	108	108
	4	10	N/A	N/A	N/A	N/A	66	51	29	N/A	100	85	53	28	122	122	103	103
	5	N/A	N/A	N/A	N/A	N/A	61	46	24	N/A	95	80	48	23	117	117	98	98
	6	N/A	N/A	N/A	N/A	N/A	56	41	19	N/A	90	75	43	18	112	112	93	93
	7	N/A	N/A	N/A	N/A	N/A	51	36	14	N/A	85	70	38	13	107	107	88	88
	8	N/A	N/A	N/A	N/A	N/A	46	31	N/A	N/A	80	65	33	N/A	102	102	83	83
	9	N/A	N/A	N/A	N/A	N/A	41	26	N/A	N/A	75	60	28	N/A	97	97	78	78
	10	N/A	N/A	N/A	N/A	N/A	36	21	N/A	N/A	70	55	23	N/A	92	92	73	73

### CONCENTRIC TERMINATION ELEVATION 0 - 10,000 ft.

Pipe Size Input	1-1/2 in.					2 in.				2-1/2 in.				3 in.				
	030	045	070	090	110	030/ 045	070	090	110	030/ 045	070	090	110	030/ 045	070	090	110	
No. of 90 ELL	1	20	15	10	N/A	N/A	73	58	42	22	105	90	64	39	121	121	114	114
	2	15	10	N/A	N/A	N/A	68	53	37	17	100	85	59	34	116	116	109	109
	3	10	N/A	N/A	N/A	N/A	63	48	32	12	95	80	54	29	111	111	104	104
	4	N/A	N/A	N/A	N/A	N/A	58	43	27	N/A	90	75	49	24	106	106	99	99
	5	N/A	N/A	N/A	N/A	N/A	53	38	22	N/A	85	70	44	19	101	101	94	94
	6	N/A	N/A	N/A	N/A	N/A	48	33	17	N/A	80	65	39	14	96	96	89	89
	7	N/A	N/A	N/A	N/A	N/A	43	28	12	N/A	75	60	34	N/A	91	91	84	84
	8	N/A	N/A	N/A	N/A	N/A	38	23	N/A	N/A	70	55	29	N/A	86	86	79	79
	9	N/A	N/A	N/A	N/A	N/A	33	18	N/A	N/A	65	50	24	N/A	81	81	74	74
	10	N/A	N/A	N/A	N/A	N/A	28	13	N/A	N/A	60	45	19	N/A	76	76	69	69

NOTES - Additional vent pipe and elbows used to terminate vent pipe outside the structure must be included in the total vent length calculation.

Intake and exhaust pipes are sized separately.

Values in table are for separate intake or exhaust pipe lengths.

Both intake and exhaust pipe must be the same size diameter.

## VENT LENGTHS - UNINSULATED EXHAUST PIPE IN UNCONDITIONED SPACE

<sup>1</sup> Winter Design Temperatures	Vent Pipe Diameter	Unit Input Size									
		030		045		070		090		110	
		Maximum Un-Insulated Exhaust Vent Length (ft.)									
		PVC	PolyPro InnoFlue	PVC	PolyPro InnoFlue	PVC	PolyPro InnoFlue	PVC	PolyPro InnoFlue	PVC	PolyPro InnoFlue
32 to 21°F	1-1/2 in.	N/A	N/A	25	N/A	20	N/A	N/A	N/A	N/A	N/A
	2 in.	N/A	N/A	18	16	31	28	50	48	30	30
	2-1/2 in.	N/A	N/A	13	N/A	24	N/A	42	N/A	56	N/A
	3 in.	N/A	N/A	9	9	18	18	35	35	47	47
20 to 1°F	1-1/2 in.	N/A	N/A	15	N/A	20	N/A	N/A	N/A	N/A	N/A
	2 in.	N/A	N/A	9	8	18	16	32	29	30	30
	2-1/2 in.	N/A	N/A	5	N/A	13	N/A	24	N/A	34	N/A
	3 in.	N/A	N/A	N/A	N/A	8	8	19	19	26	26
0 to -20°F	1-1/2 in.	N/A	N/A	10	N/A	15	N/A	N/A	N/A	N/A	N/A
	2 in.	N/A	N/A	5	N/A	12	10	22	19	30	27
	2-1/2 in.	N/A	N/A	N/A	N/A	7	N/A	15	N/A	22	N/A
	3 in.	N/A	N/A	N/A	N/A	N/A	N/A	10	10	16	16

NOTE - Concentric terminations are equivalent to 5 ft. of straight pipe and should be included when measuring total pipe length.

NOTE - Each elbow is equivalent to 5 ft. of straight pipe and should be included when measuring total pipe length.

<sup>1</sup> Refer to 99% Minimum Design Temperature table provided in the current edition of the ASHRAE Handbook-Fundamentals.

PolyPro® poly-propylene vent pipe is a registered trademark of DuraVent®.

InnoFlue® is a registered trademark of Centrotherm Eco Systems.

## BLOWER DATA

### EL196UH030XE24B AND EL196UH045XE24B PERFORMANCE (Less Filter)

External Static Pressure in. w.g.	Air Volume / Watts at Various Blower Speeds									
	High		Medium-High		Medium		Medium-Low		Low	
	cfm	Watts	cfm	Watts	cfm	Watts	cfm	Watts	cfm	Watts
0.00	1125	160	1015	125	935	105	830	65	905	70
0.10	1070	165	980	130	885	110	775	70	700	60
0.20	1035	175	950	140	845	115	715	75	560	50
0.30	1000	185	915	150	810	125	670	85	495	55
0.40	965	195	875	160	770	135	625	95	435	60
0.50	925	205	835	170	730	140	580	100	365	65
0.60	890	215	800	180	685	150	530	105	325	70
0.70	855	225	770	190	635	155	485	110	270	75
0.80	820	230	720	195	600	165	430	115	230	80

### EL196UH045XE36B PERFORMANCE (Less Filter)

External Static Pressure in. w.g.	Air Volume / Watts at Various Blower Speeds									
	High		Medium-High		Medium		Medium-Low		Low	
	cfm	Watts	cfm	Watts	cfm	Watts	cfm	Watts	cfm	Watts
0.00	1460	335	1285	235	1190	170	910	85	870	75
0.10	1430	350	1260	245	1155	185	885	95	830	85
0.20	1405	365	1235	255	1125	200	860	105	800	90
0.30	1375	370	1205	265	1090	210	825	115	755	95
0.40	1350	380	1175	275	1055	215	780	125	710	105
0.50	1315	385	1145	285	1020	230	735	130	665	115
0.60	1245	375	1110	295	980	240	685	140	620	125
0.70	N/A	N/A	1070	305	940	250	640	145	575	135
0.80	N/A	N/A	1020	310	905	260	600	155	530	140

### EL196UH070XE36B PERFORMANCE (Less Filter)

External Static Pressure in. w.g.	Air Volume / Watts at Various Blower Speeds									
	High		Medium-High		Medium		Medium-Low		Low	
	cfm	Watts	cfm	Watts	cfm	Watts	cfm	Watts	cfm	Watts
0.00	1445	315	1315	215	1215	165	930	85	925	75
0.10	1445	335	1275	230	1170	180	905	94	860	80
0.20	1415	345	1240	240	1125	190	870	101	800	85
0.30	1380	355	1205	250	1090	200	830	109	760	95
0.40	1345	370	1175	265	1055	210	790	117	710	105
0.50	1315	385	1150	280	1020	220	735	129	665	115
0.60	1275	390	1110	290	985	230	685	137	625	125
0.70	1210	395	1075	300	950	240	640	146	565	130
0.80	N/A	N/A	1030	305	915	250	595	148	535	135

### EL196UH090XE48C PERFORMANCE (Less Filter)

External Static Pressure in. w.g.	Air Volume / Watts at Various Blower Speeds									
	High		Medium-High		Medium		Medium-Low		Low	
	cfm	Watts	cfm	Watts	cfm	Watts	cfm	Watts	cfm	Watts
0.00	1765	375	1535	250	1410	180	1315	155	1155	115
0.10	1735	390	1500	260	1365	200	1270	165	1130	125
0.20	1700	405	1465	275	1330	215	1230	175	1095	135
0.30	1660	425	1435	290	1295	225	1195	190	1055	145
0.40	1640	435	1400	300	1265	235	1165	200	1010	155
0.50	1615	450	1370	315	1230	250	1125	215	965	165
0.60	1575	465	1340	325	1190	265	1080	230	925	180
0.70	1530	470	1305	340	1150	280	1045	235	885	190
0.80	N/A	N/A	1260	345	1115	285	1000	245	845	195

## BLOWER DATA

### EL196UH110XE60C PERFORMANCE (Less Filter)

External Static Pressure in. w.g.	Air Volume / Watts at Different Blower Speeds																			
	Bottom Return Air, Side Return Air with Return Air from Both Sides or Return Air from Bottom and One Side.										Single Side Return Air – Air volumes in <b>bold</b> (over 1800 cfm) require Optional Return Air Base <u>and</u> field fabricated transition to accommodate 20 x 25 x 1 in. air filter in order to maintain proper air velocity.									
	High		Med-High		Medium		Med-Low		Low		High		Med-High		Medium		Med-Low		Low	
	cfm	Watts	cfm	Watts	cfm	Watts	cfm	Watts	cfm	Watts	cfm	Watts	cfm	Watts	cfm	Watts	cfm	Watts	cfm	Watts
0.00	2220	655	1975	440	1800	325	1665	390	1050	180	<b>2180</b>	<b>685</b>	<b>1910</b>	<b>460</b>	1750	345	1660	285	1430	195
0.10	2185	680	1925	460	1750	345	1625	285	1440	200	<b>2155</b>	<b>705</b>	<b>1885</b>	<b>480</b>	1720	360	1610	295	1415	205
0.20	2150	705	1880	480	1710	365	1590	300	1390	220	<b>2130</b>	<b>725</b>	<b>1855</b>	<b>495</b>	1685	380	1565	305	1380	220
0.30	2110	720	1850	495	1680	380	1560	320	1350	230	<b>2085</b>	<b>745</b>	<b>1825</b>	<b>510</b>	1655	390	1535	325	1335	230
0.40	2080	735	1810	520	1650	405	1515	330	1310	245	<b>2060</b>	<b>760</b>	1795	530	1625	405	1495	340	1295	245
0.50	2045	755	1785	530	1610	415	1470	350	1265	255	<b>2030</b>	<b>775</b>	1765	545	1585	425	1450	355	1255	265
0.60	2010	775	1740	545	1575	430	1440	370	1220	270	<b>1995</b>	<b>785</b>	1725	565	1550	435	1420	370	1205	275
0.70	1980	790	1705	565	1525	450	1400	375	1170	280	<b>1960</b>	<b>795</b>	1690	575	1505	455	1385	385	1165	290
0.80	1950	795	1670	580	1485	460	1360	390	1140	293	<b>1895</b>	<b>790</b>	1650	590	1465	470	1335	395	1120	295

# DIMENSIONS - UPFLOW POSITION

<sup>1</sup> NOTE - 60C size units that require air volumes over 1800 cfm must have one of the following:

1. Single side return air and Optional Return Air Base with transition that must accommodate required 20 x 25 x 1 inch (508 x 635 x 25 mm) air filter to maintain proper velocity.
  2. Bottom return air.
  3. Return air from both sides.
  4. Bottom and one side return air.
- See Blower Performance Tables for additional information.

<sup>2</sup> Optional Side Return Air Filter Kit is not for use with the Optional Return Air Base.

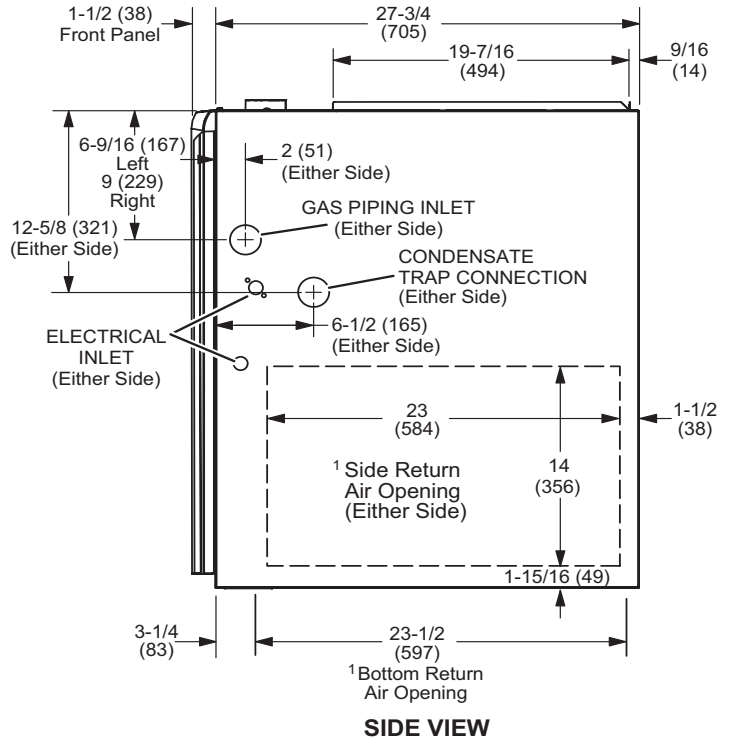
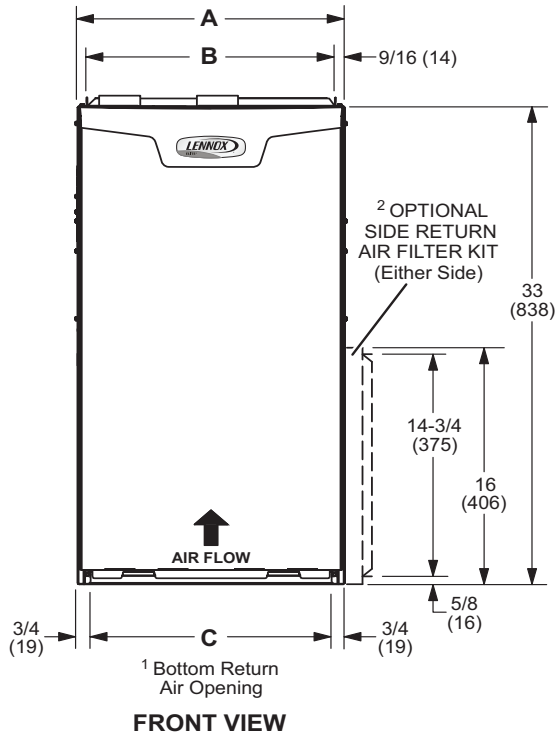
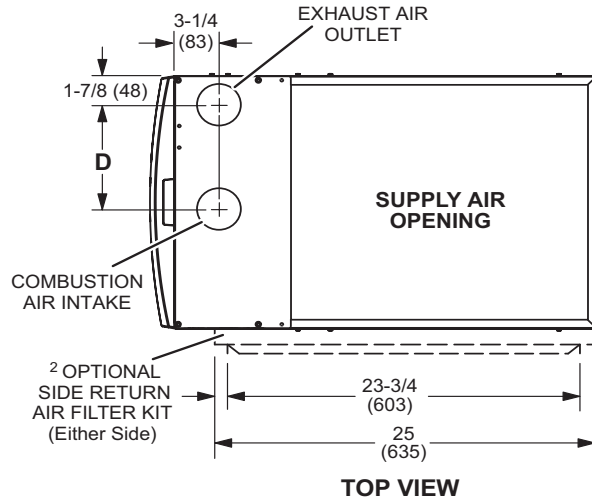

Model No.	A		B		C		D	
	in.	mm	in.	mm	in.	mm	in.	mm
EL196UH030XE24B EL196UH045XE24B EL196UH045XE36B EL196UH070XE36B	17-1/2	446	16-3/8	416	16	406	7-5/8	194
EL196UH090XE48C EL196UH110XE60C	21	533	19-7/8	505	19-1/2	495	9-3/8	238

# DIMENSIONS - HORIZONTAL POSITION

## LEFT-HAND AIR DISCHARGE

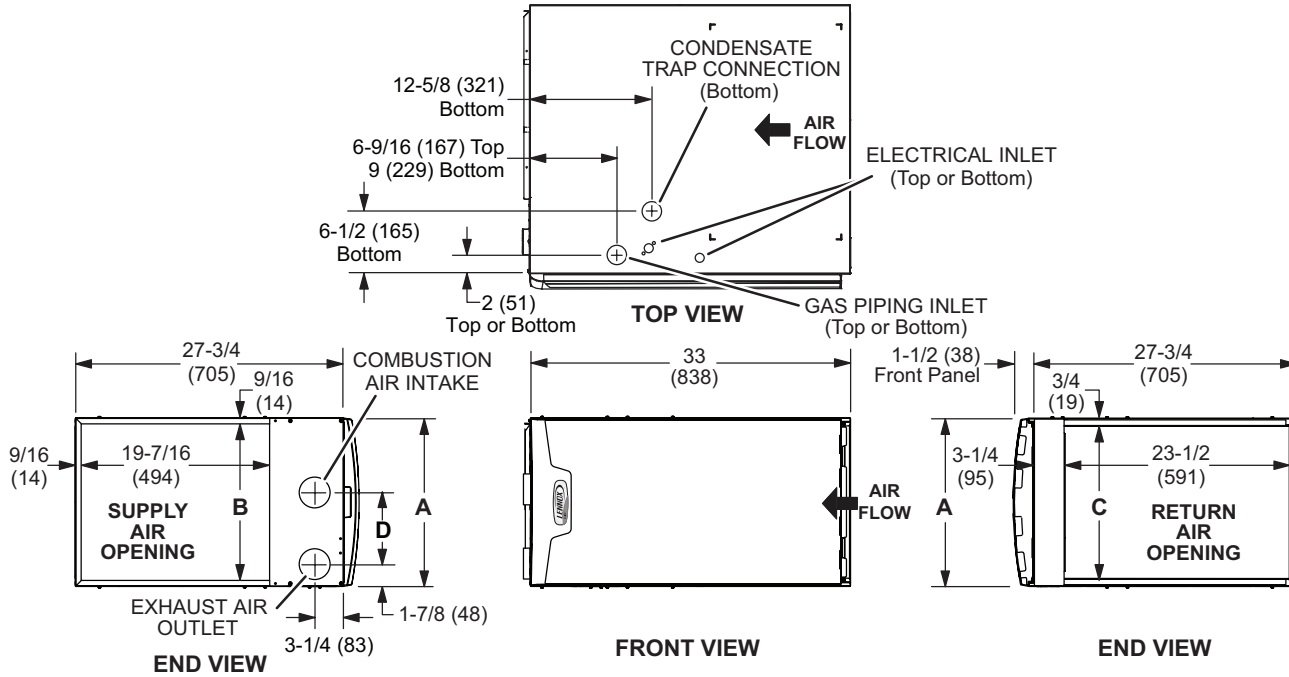

## RIGHT-HAND AIR DISCHARGE

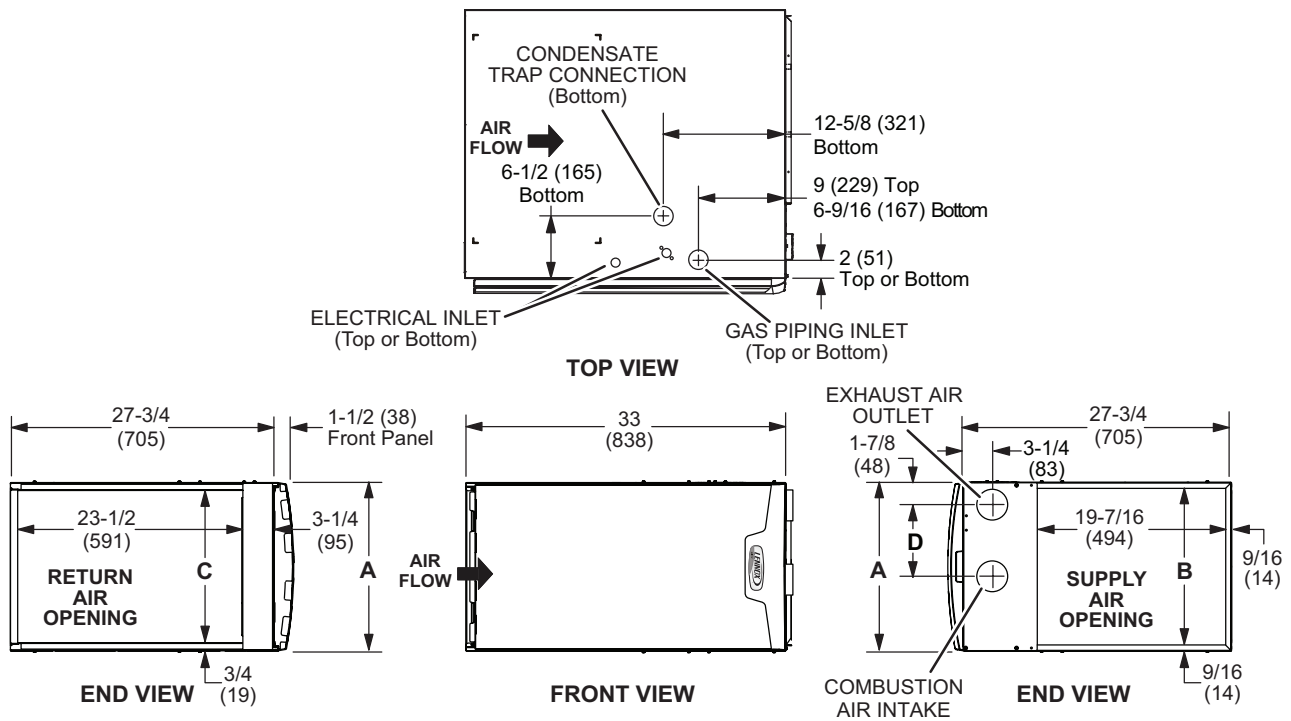

Model No.	A		B		C		D	
	in.	mm	in.	mm	in.	mm	in.	mm
EL196UH030XE24B	17-1/2	446	16-3/8	416	16	406	7-5/8	194
EL196UH045XE24B								
EL196UH045XE36B								
EL196UH070XE36B								
EL196UH090XE48C	21	533	19-7/8	505	19-1/2	495	9-3/8	238
EL196UH110XE60C								



## DIMENSIONS - OPTIONAL ACCESSORIES

### HORIZONTAL (END) FILTER KIT

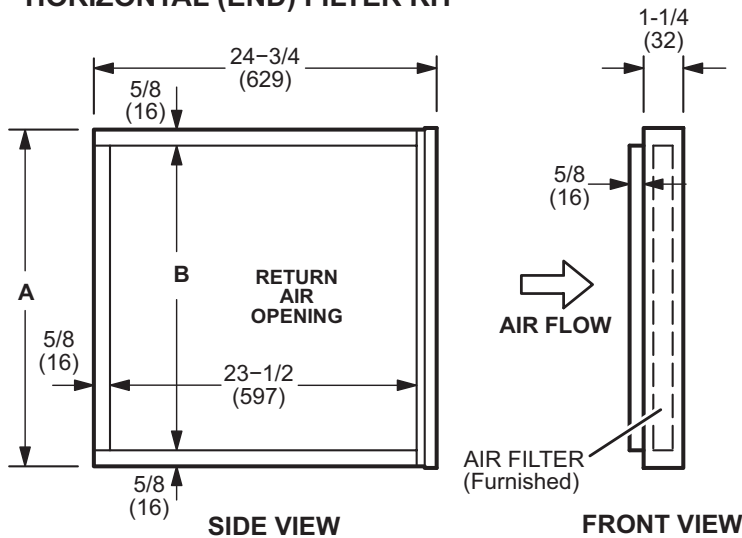

Furnace Cabinet Width	Catalog Number	A		B	
		in.	mm	in.	mm
B	87L96	18	457	16-3/4	425
C	87L97	21	533	18-3/4	476
D	87L98	25	635	23-3/4	603

### OPTIONAL RETURN AIR BASE (Upflow Applications Only - For use with B, C and D cabinets)

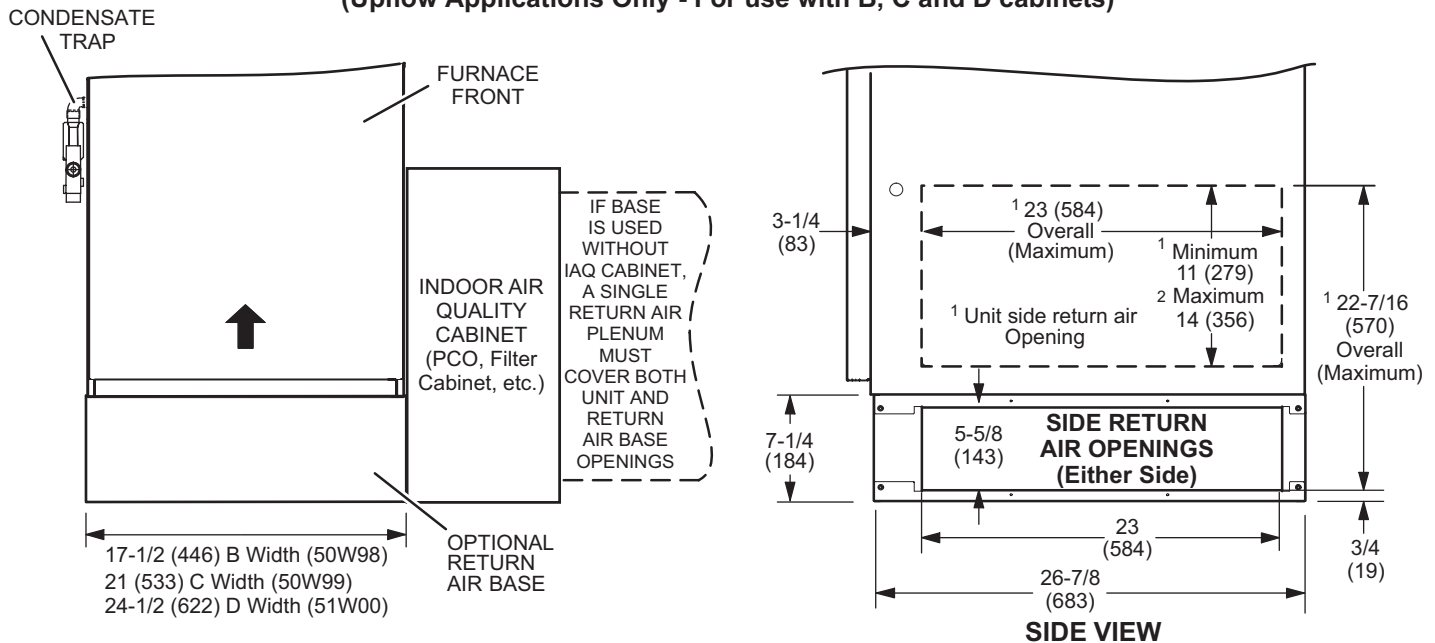

**NOTE-** Optional Side Return Air Filter Kits are not for use with Optional Return Air Base.

<sup>1</sup> Both the unit return air opening and the base return air opening must be covered by a single plenum or IAQ cabinet. Minimum unit side return air opening dimensions for units requiring 1800 cfm or more of air (W x H): 23 x 11 in. (584 x 279 mm). The opening can be cut as needed to accommodate plenum or IAQ cabinet while maintaining dimensions shown.

Side return air openings must be cut in the field. There are cutting guides stenciled on the cabinet for the side return air opening. The size of the opening must not extend beyond the markings on the furnace cabinet.

<sup>2</sup> To minimize pressure drop, the largest opening height possible, up to 14 in. (356 mm), is preferred.

## DIMENSIONS - FURNACE/COIL COMBINED DIMENSIONS

### UPFLOW POSITION

Model No			C35/C37/CX35/CX38 Cased				C35 Uncased			
			A		B		A		B	
C35/CX35	C37	CX38	in.	mm	in.	mm	in.	mm	in.	mm
C35/CX35-18/24A C35/CX35-18/24B	---	---	16-1/2	419	49-1/2	1257	14-1/8	359	47-1/8	1197
C35/CX35-24A C35/CX35-24B	C37-25A C37-25B	CX38-25A CX38-25B	18-1/2	470	51-1/2	1308	16-3/8	416	49-3/8	1254
---	---	CX38-30A	20-1/2	521	53-1/2	1359	---	---	---	---
C35/CX35-30A C35/CX35-30B	C37-31A C37-31B	CX38-31A CX38-31B	22-1/2	572	55-1/2	1410	20-3/4	527	53-3/4	1365
C35/CX35-30/36A C35/CX35-30/36B C35/CX35-30/36C	C37-36A C37-36B C37-36C	CX38-36A CX38-36B CX38-36C	24-1/2	622	57-1/2	1461	22-1/4	565	55-1/4	1403
C35/CX35-36A C35/CX35-36B	C37-38A C37-38B	CX38-38A CX38-38B	24-1/2	622	57-1/2	1461	22-3/8	568	55-3/8	1407
---	C37-42B	CX38-42B	24-1/2	622	57-1/2	1461	---	---	---	---
C35/CX35-48B C35/CX35-48C	C37-43B C37-43C	CX38-43B CX38-43C	27-1/2	699	60-1/2	1537	26-1/4	667	59-1/4	1505
---	C37-48B C37-48C	CX38-44/48B CX38-44/48C	24-1/2	622	57-1/2	1461	---	---	---	---
C35/CX35-49C	C37-49C	CX38-49C	29-1/2	749	62-1/2	1588	28-1/2	724	61-1/2	1562
C35/CX35-50/60C	C37-50/60C	CX38-50/60C	27-1/2	699	60-1/2	1537	25-7/8	657	58-7/8	1495
CX35-60C	C37-62C	CX38-62C	31-1/2	800	64-1/2	1638	30-5/8	778	63-5/8	1616

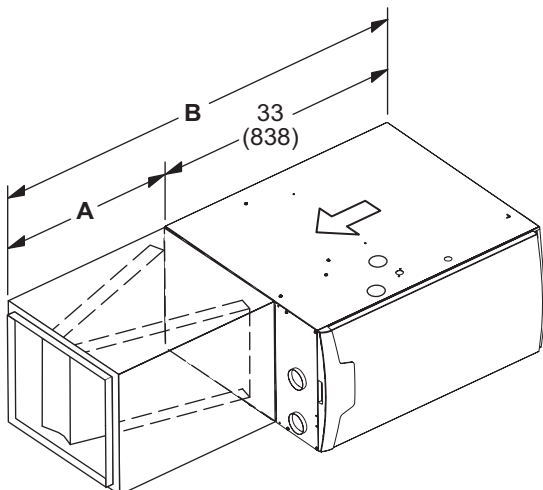
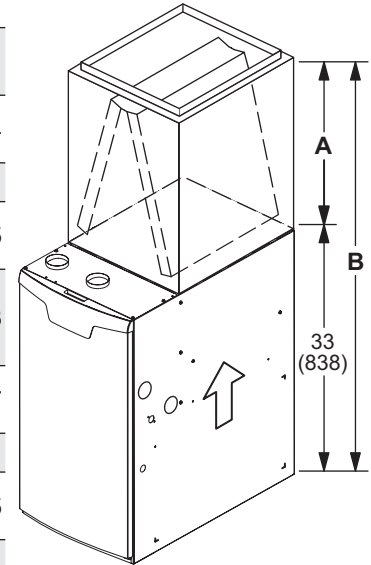

### HORIZONTAL POSITION

Model Number	A		B	
	in.	mm	in.	mm
<b>CH33</b>				
CH33-18A-2F	21-1/2	546	54-1/2	1384
CH33-24/30A-2F, CH33-42B-2F, CH33-36A-2F, CH33-48C-2F, CH33-36B-2F, CH33-36C-2F,	26-1/2	673	59-1/2	1511
CH33-44/48B-2F, CH33-50/60C-2F,	31-1/2	800	64-1/2	1638
<b>CH(X)35</b>				
CH(X)35-18A-2F, CH(X)35-36A-2F, CH(X)35-24A-2F, CH(X)35-36B-2F, CH(X)35-24B-2F, CH(X)35-36C-2F, CH(X)35-30B-2F, CH(X)35-42C-2F, CH(X)35-48C-2F	26-1/2	673	59-1/2	1511
CH(X)35-30A-2F, CH(X)35-51C-2F, CH(X)35-42B-2F, CH(X)35-48B-2F,	31-1/2	880	64-1/2	1638

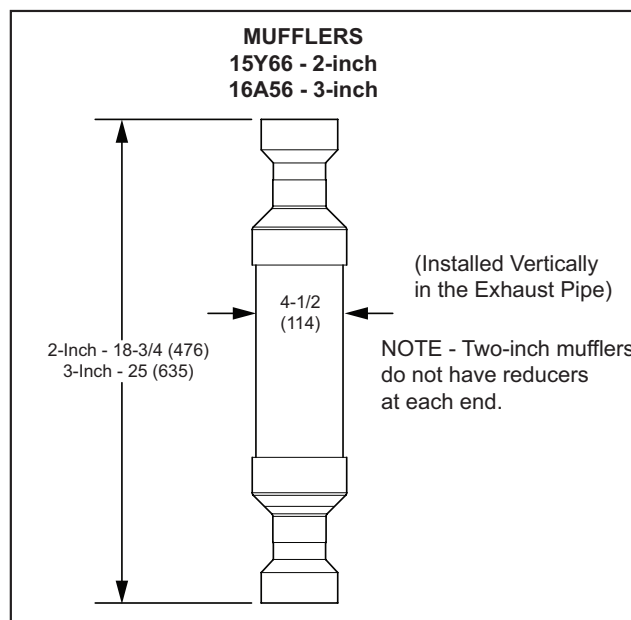
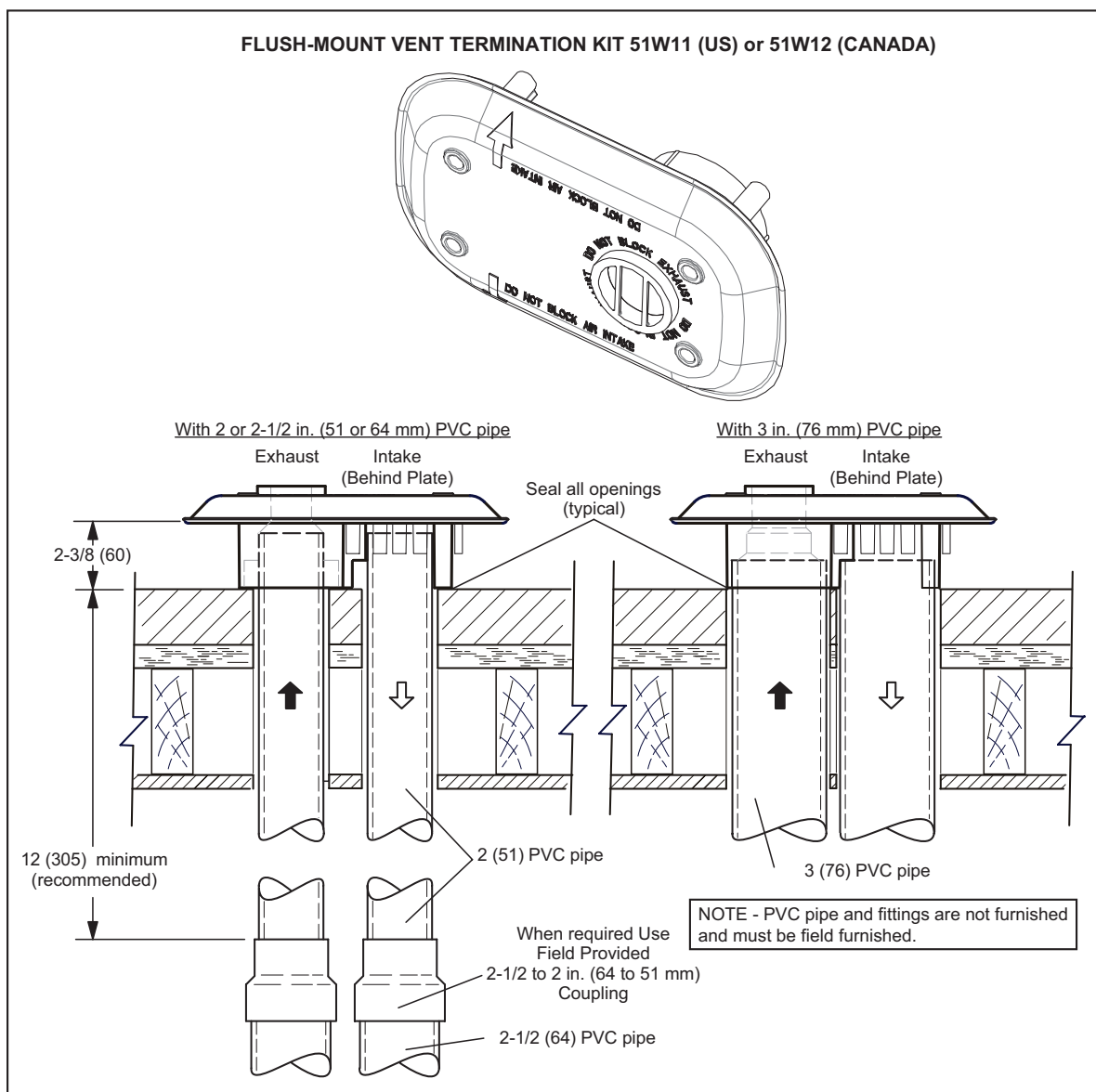

# DIMENSIONS - OPTIONAL ACCESSORIES - VENTING

## CONCENTRIC WALL TERMINATION APPLICATIONS

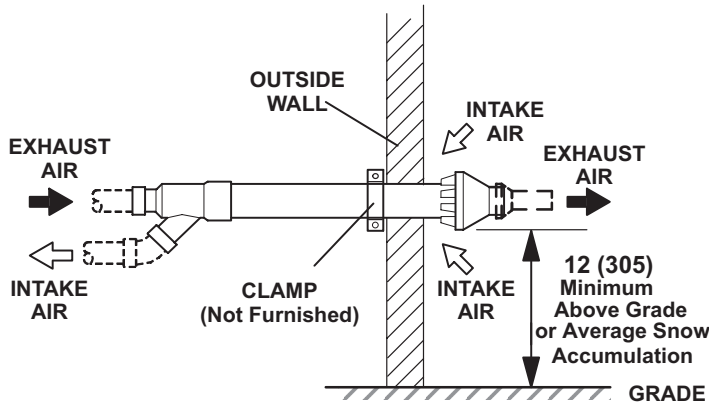

## CONCENTRIC ROOF TERMINATION APPLICATIONS

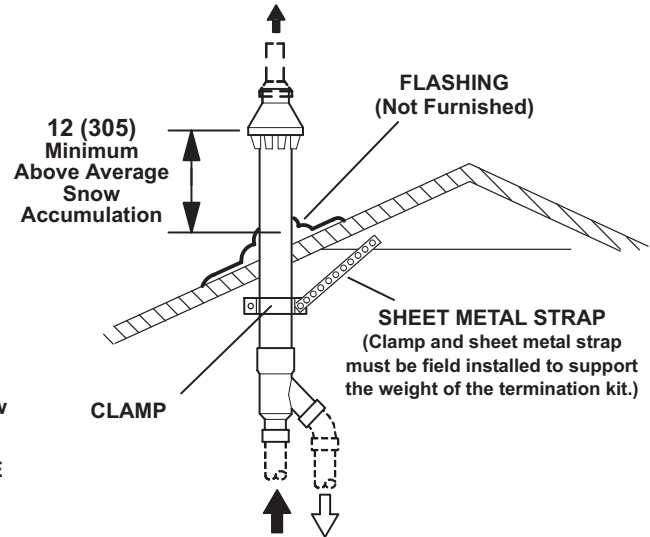

71M80 / 69M29 / 44W92 – 2 inch kits  
 60L46 / 44W93 – 3 inch kits  
 See Installation Instructions for additional information.

Note - Field provided reducer may be required to adapt different vent pipe sizes to termination.

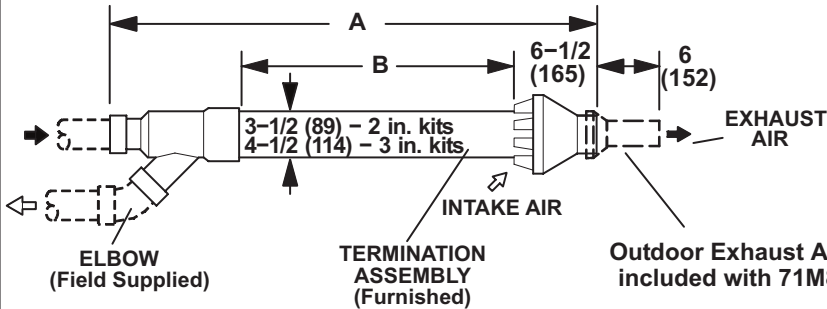

Cat. No.	A		B	
	in.	mm	in.	mm
71M80 69M29	33-3/8	848	16-3/4	425
44W92 (Canada)	29	737	15-1/2	394
60L46	38-7/8	987	21-3/16	538
44W93 (Canada)	36-1/8	918	19-1/2	495

NOTE - Typical illustration for dimensions only. Design may vary depending on kit ordered.

## WALL ASSEMBLY TERMINATION KIT – RING KIT 15F74 – 2 inch (51 mm)

See Installation Instructions for additional information.

Note - Field provided reducer may be required to adapt larger vent pipe size to termination.

### DIRECT VENT APPLICATION

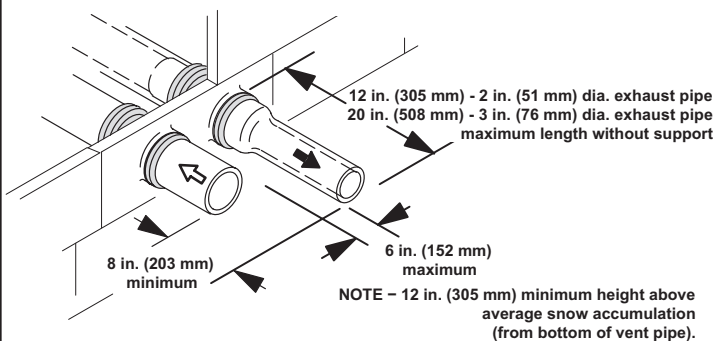

### NON-DIRECT VENT APPLICATION

NOTE - EXHAUST PIPE SHOWN  
 Kit Contains Enough Parts For Two Installations

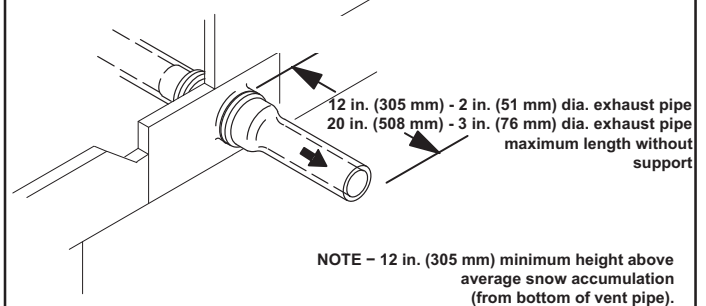

**WALL TERMINATION KITS (CLOSE-COUPLE)  
EXTENDED VENT FOR GRADE CLEARANCE  
2 inch (51 mm) 22G44 (US)  
3 inch (76 mm) 44J40 (US)**

**See Installation Instructions for additional information.**

Note - Field provided reducer may be required to adapt different vent pipe sizes to termination.

If Intake and Exhaust Pipe is less than 12 in. (305 mm) above snow accumulation or other obstructions, field fabricated piping must be installed.

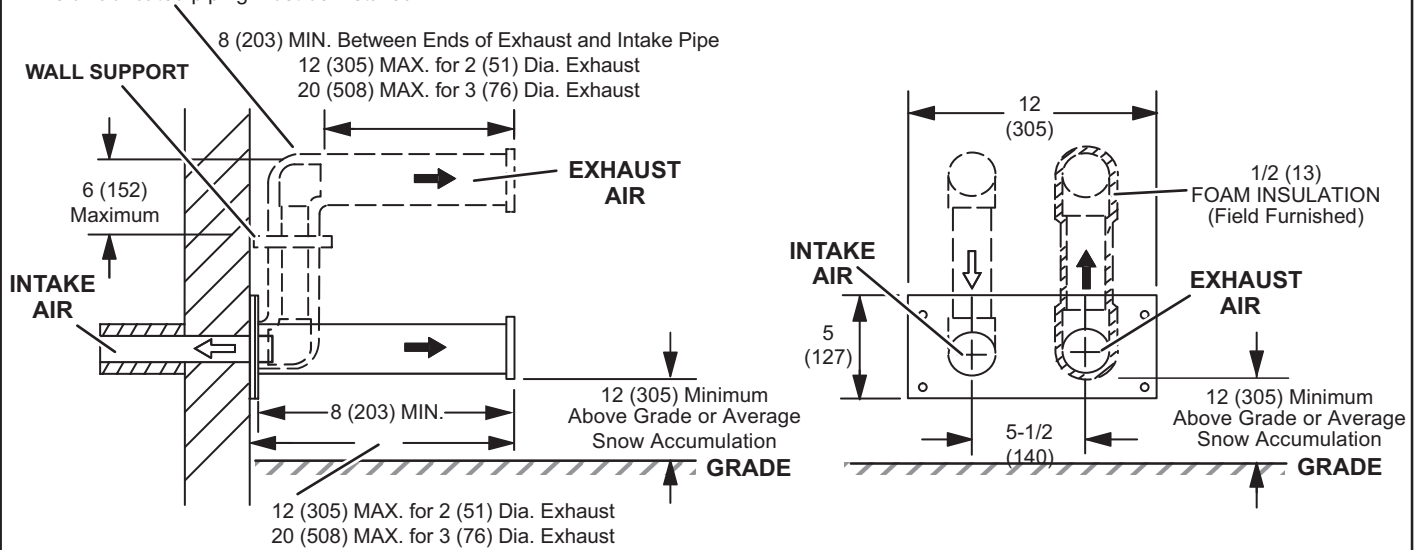

**WALL TERMINATION KITS (CLOSE-COUPLE)  
EXTENDED VENT FOR GRADE CLEARANCE  
2 inch (51 mm) 30G28 (WTK Canada)  
3 inch (76 mm) 81J20 (WTK Canada)**

**See Installation Instructions for additional information.**

Note - Field provided reducer may be required to adapt different vent pipe sizes to termination.

If Intake and Exhaust Pipe is less than 12 in. (305 mm) above snow accumulation or other obstructions, field fabricated piping must be installed.

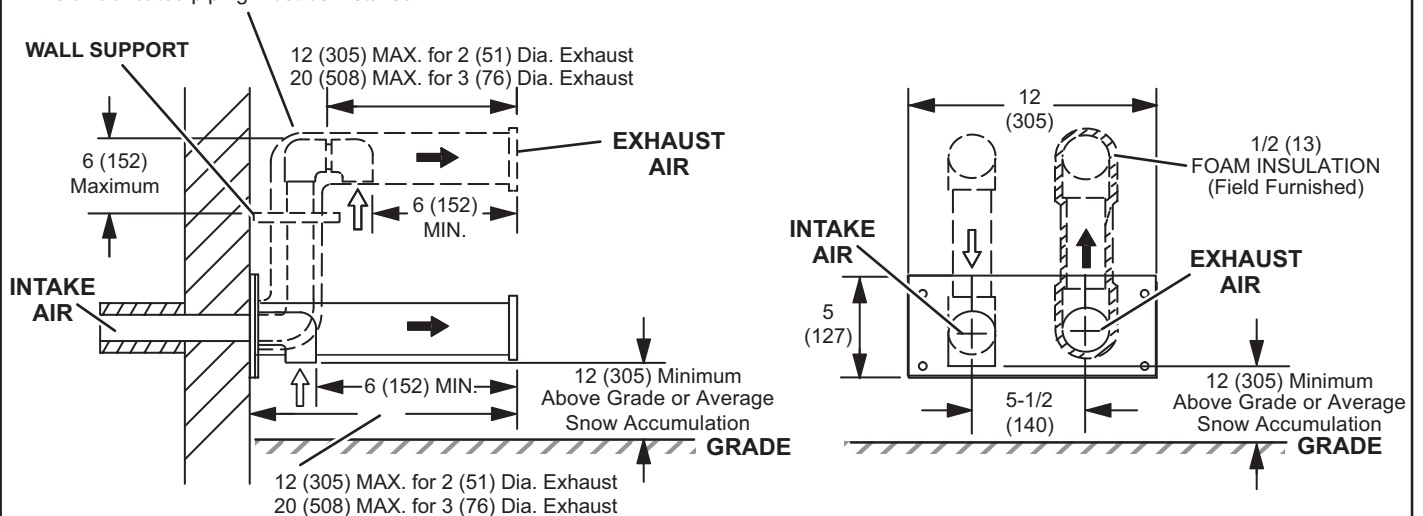





## REVISIONS

Sections	Description of Change
Gas Heat Accessories	New High Altitude Pressure Switch Kit for 070 input models.



Visit us at [www.lennox.com](http://www.lennox.com)

For the latest technical information, [www.LennoxPros.com](http://www.LennoxPros.com)

Contact us at 1-800-4-LENNOX

NOTE - Due to Lennox' ongoing commitment to quality, Specifications, Ratings and Dimensions subject to change without notice and without incurring liability. Improper installation, adjustment, alteration, service or maintenance can cause property damage or personal injury. Installation and service must be performed by a qualified installer and servicing agency.

©2020 Lennox Industries, Inc.