



**RESIDENTIAL
PRODUCT SPECIFICATIONS**

Bulletin No. 210872
November 2020
Supersedes July 2020



**ELITE®
SERIES**

AFUE - 80%
Input - 66,000 to 88,000 Btuh
Nominal Add-on Cooling - 1.5 to 4 Tons

MODEL NUMBER IDENTIFICATION

EL 2 80 DF 070 E 36 A

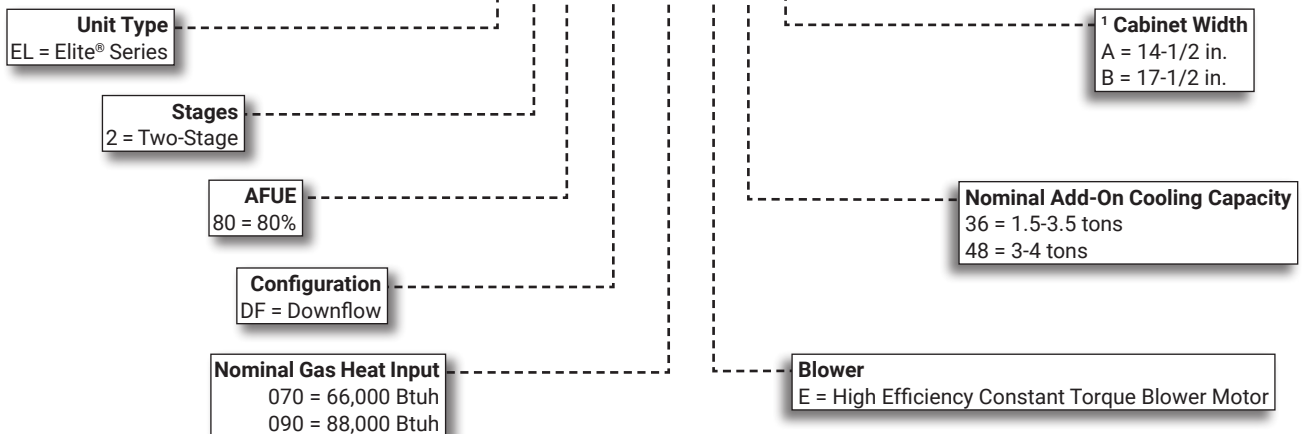

¹ Downflow indoor coils with the same letter designation will physically match the furnace supply air opening.

FEATURE HIGHLIGHTS

1. Lennox Duralok™ Heat Exchanger
2. Inshot Burners
3. SureLight® Hot Surface Ignitor
4. Two-Stage Gas Control Valve
5. Two-Speed Combustion Air Inducer
6. Flame Rollout Switches
7. SureLight® Integrated Furnace Control
8. Power Saver™ Constant Torque Blower
9. Insulated Cabinet
10. Safety Interlock Switch
11. Gas Piping And Electrical Inlets

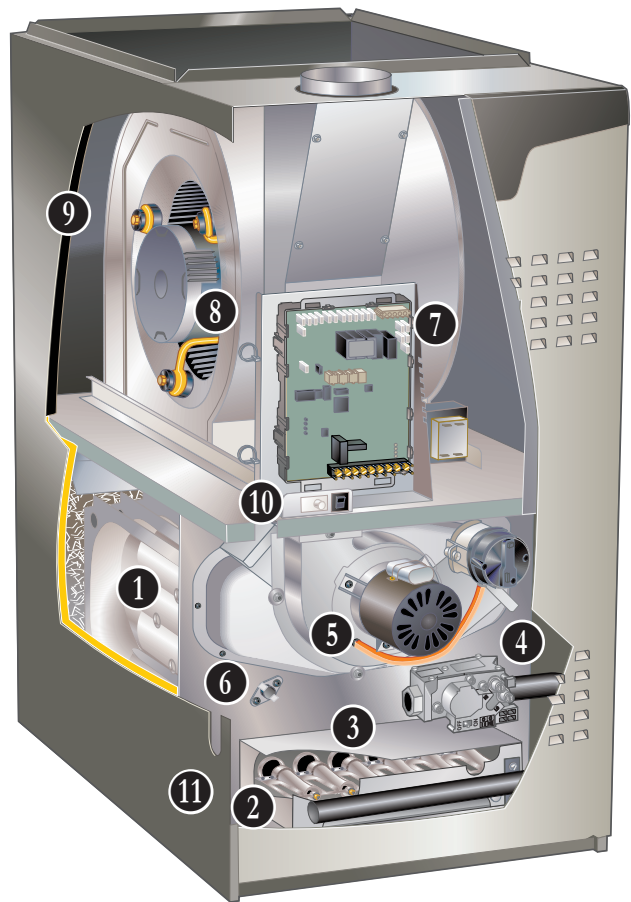

NOTE - EL280DFE FURNACES ARE NOT AVAILABLE IN CANADA!

CONTENTS

Approvals And Warranty	3
Blower Data	11
Dimensions	8
- Unit	8
- Optional Accessories	9
- Furnace/Coil Combined Dimensions	10
Features	3
Gas Heat Accessories	7
High Altitude Derate	7
Installation Clearances	7
Model Number Identification.	1
Optional Accessories - Order Separately	6
Specifications	6

APPROVALS AND WARRANTY

APPROVALS

- AHRI Certified
- CSA International Certified
- Tested and rated according to US DOE test procedures and FTC labeling regulations
- ISO 9001 Registered Manufacturing Quality System
- Blower data from unit tests conducted in Lennox Laboratory air test chamber

California Only

- These furnaces **do not meet** the South Coast Air Quality Management District (SCAQMD) Rule 1111 and San Joaquin Valley Air Pollution Control District (SJVAPCD) Rule 4905 NOx emission limit (14 ng/J) and cannot be installed within the SCAQMD and SJVAPCD areas

WARRANTY

- Duralok™ Aluminized Steel Heat Exchanger:
 - Limited twenty years in residential applications
 - Limited ten years in non-residential applications
- All other covered components:
 - Limited five years in residential installations
 - Limited one year in non-residential installations

NOTE - Refer to Lennox Equipment Limited Warranty certificate included with unit for specific details.

FEATURES

APPLICATIONS

- Input capacities of 66,000 and 88,000 Btuh
- Energy efficiency (AFUE) -80%
- Lennox add-on indoor coils, high-efficiency air cleaners and humidifiers can easily be added to furnace
- Shipped factory assembled with all controls installed and wired
- Each unit factory test operated to ensure proper operation

HEATING SYSTEM

- 1 Lennox Duralok™ Heat Exchanger Assembly**
 - Heavy gauge aluminized steel heat exchanger
 - Crimped seam clamshell type design
 - Designed for normal expansion and contraction
 - Minimum resistance to air flow
 - Heat exchanger has been laboratory life cycle tested in excess of industry standards
 - Compact size of heat exchanger permits low overall design of furnace cabinet
- 2 Inshot Burners**
 - Aluminized steel inshot burners provide efficient, trouble-free operation
 - Burner venturi mixes air and gas in correct proportion for proper combustion
 - Burner assembly is removable from the unit as a single component for ease of service

- 3 SureLight® Hot Surface Ignitor**
 - Tough, reliable, long-life, trouble-free performance
 - Silicon nitride ignitor
 - Cemented to steatite block for protection against current leakage
 - Ignition leads are constructed of nickel plated copper and are enclosed in high temperature Teflon® insulation for dependable operation
- 4 Two-Stage Gas Control Valve**
 - 24 volt redundant combination two-stage gas control valve combines manual shut off switch (On-Off), automatic electric valve (dual) and gas pressure regulation into a compact combination control
- 5 Two-Speed Combustion Air Inducer**
 - Heavy duty, permanent split capacitor (PSC) two-speed blower prepurges heat exchanger and safely vents flue products
 - Dual pressure switches (low fire/high fire) prove blower operation before allowing gas valve to open
 - Operates only during heating cycle
- 6 Flame Rollout Switch**
 - Factory installed on burner box
 - Switch provides protection from abnormal operating conditions
 - Manual reset

FEATURES

HEATING SYSTEM (continued)

Limit Control

- Primary limit factory installed on vestibule panel
- Secondary limit factory installed on blower housing
- Automatic reset

Optional Accessories

High Altitude Pressure Switch Kit

- Required on most units for proper unit operation at altitudes from 4501 to 10,000 ft.

Natural Gas to LPG/Propane Conversion Kit

- Required for field changeover from natural gas to LPG/Propane

LPG/Propane to Natural Gas Conversion Kit

- Required for field changeover from LPG/Propane to natural gas

CONTROLS

7 SureLight® Integrated Two-Stage Furnace Control

- Contains all necessary controls and relays to operate furnace
- Combustion air inducer is operated by the integrated furnace control
- Prior to ignition, a pre-purge cycle for 15 seconds is initiated
- After the main burners are turned off, a post-purge cycle for 5 seconds is run
- Flame sensor assures safe and reliable operation
- Should loss of flame occur the integrated furnace control will initiate 4 re-attempts at ignition before locking out unit operation for 60 minutes
- Watchguard type circuit automatically resets ignition controls after one hour of continuous thermostat demand after unit lockout, eliminating nuisance calls for service
- Jumper settings for single or two stage thermostat operation
- Two selectable 2nd stage recognition times (10 and 15 minutes) are available when the furnace is used with a single stage thermostat
- When used with a two stage thermostat, furnace will only initiate second stage operation with a second stage thermostat demand
- Fan control consists of adjustable blower timed-off delay (60, 90, 120, 180 seconds - factory setting 90 seconds) and fixed blower timed-on delay (30 seconds heating, 2 seconds cooling)
- For air-conditioning applications, blower is automatically energized on thermostat demand for cooling
- Two accessory terminals furnished for additional power supply requirements for 120 volt (less than 1 amp) power humidifiers and powered air cleaners
- A separate 24V accessory terminal is also provided for low voltage accessories
- Ignition control has single red LED to indicate status and as an aid in troubleshooting

24 Volt Transformer

- Furnished and factory installed outside of the control box
- 40VA transformer has circuit breaker wired in series

Field Wiring Make-Up Box

- Furnished for line voltage wiring
- Factory installed internally on left side of furnace
- Box may be installed on right side of furnace

Optional Accessories

iComfort® E30 Smart Wi-Fi Thermostat

- Wi-Fi enabled, electronic 7-day, universal, multi-stage, programmable, touchscreen thermostat
- 3 Heat/2 Cool
- Auto-changeover
- Controls dehumidification during cooling mode and humidification during heating mode
- Offers enhanced capabilities including humidification / dehumidification / dewpoint measurement and control, Humiditol® control, and equipment maintenance reminders
- Easy to read 7 in. color touchscreen (measured diagonally)
- LCD display with backlight shows the current and set temperature, time, inside relative humidity, system status (operating mode and schedules) and outside temperature (optional outdoor sensor required)
- Smooth Setback Recovery starts system early to achieve setpoint at start of program period
- Compressor short-cycle protection (5 minutes)
- Up to four separate schedules are available plus Schedule IQ™
- One-Touch Away Mode - A quick and easy way to set the cooling and heating setpoints while away
- Smart Away™ - Uses geo-fencing technology to determine when the homeowner is within a predetermined distance from the home to operate the system when leaving, away and arriving
- Wi-Fi remote monitoring and adjustment through a home wireless network for desktop PCs, laptops and apps for smartphones or tablets
- Smart home automation compatible with Apple HomeKit™, Amazon Alexa®, Google Assistant and IFTTT
- Service Dashboard features online real-time monitoring of installed iComfort® thermostats
- High Definition Color Display with Subbase, Smart Hub Controller, wallplate (for retrofit installations) furnished for easy installation
- See the iComfort® E30 Smart Wi-Fi Thermostat Product Specifications bulletin for more information



FEATURES

CONTROLS (continued)

Remote Outdoor Temperature Sensor

- iComfort® E30 Smart Thermostat
- When installed outdoors, sensor allows thermostat to display outdoor temperature

NOTE - Sensor is required for Enhanced Dehumidification Control (EDA) applications.

NOTE - The outdoor sensor is furnished as standard with iComfort® Communicating outdoor units, optional for conventional units.



Thermostat

- Thermostat is not furnished with unit
- See Lennox Price Book for selection

Furnace Twinning Kit

- Required to operate two furnaces simultaneously.
- Kit consists of twinning relays, quick connect terminals and mounting hardware
- Used for two-stage heating/single-stage cooling with either a single-stage or two-stage thermostat

Night Service Kit

- Contains most commonly used service parts
- Furnace control
- Gas valve
- Ignitor
- Transformer
- Flame sensor
- Service manual

BLOWER

- Direct drive blower
- Statically and dynamically balanced
- Resiliently mounted
- Blower assembly easily removed for servicing

8 Power Saver™ Constant Torque Blower Motor

- DC Brushless Motor
- High Efficiency Constant Torque
- ECM (Electronically Commutated Motor)
- Motor is programmed to provide constant torque at each of the selectable speeds
- Motor is controlled by the Integrated Furnace Control
- Blower speeds are easily changed on the integrated furnace control
- See Blower Data tables

CABINET

- Low-profile, narrow width cabinet allows easy installation in downflow applications
- Heavy-gauge, cold rolled steel construction
- Pre-painted cabinet finish
- Flanges provided on return air opening for ease of plenum connection
- 9** • Insulated with foil faced insulation on sides and back of heating compartment and mat faced insulation in blower compartment
- Sealed blower compartment
- Inner blower compartment access panel seals blower compartment from air leakage
- Cabinet door can be removed without any tools
- Complete service access
- 10** • Safety interlock switch automatically shuts off power to unit when inner blower compartment access panel is removed
- 11** • Gas piping and electrical inlets are provided in both sides of cabinet

Coil Match-Up

- All Lennox downflow indoor coils will physically match the furnace **supply air opening** with the same letter designation (A, B, C, D) as in the furnace model number

Low Leakage Cabinet

- All models have less than 2% air leakage and meet ANSI/ASHRAE Standard 193-2010 "Method of Test for Determining the Air Tightness of HVAC Equipment"

Optional Accessories

Downflow Combustible Flooring Base

- Required for heating only units installed on combustible flooring
- Not required in add-on cooling applications
- See Dimension drawing

FILTER (not furnished)

- Filter and provisions for external mounting must be field provided

Optional Accessories

Downflow Filter Kit

- Filter cabinet mounts directly on top of furnace
- "A" width cabinet includes one filter
- "B" width cabinets include two filters
- Filter rails are furnished
- Front access for servicing
- Cleanable filter(s) are furnished

SPECIFICATIONS

Gas Heating Performance	Model No.	EL280DF070E36A	EL280DF090E48B
	¹ AFUE	80%	80%
High Fire	Input - Btuh	66,000	88,000
	Output - Btuh	52,000	69,000
	Temperature rise range - °F	30 - 60	35 - 65
	Gas Manifold Pressure (in. w.g.) Nat. Gas / LPG/Propane	3.5 / 10.0	3.5 / 10.0
Low Fire	Input - Btuh	43,000	57,000
	Output - Btuh	35,000	46,000
	Temperature rise range - °F	20 - 50	20 - 50
	Gas Manifold Pressure (in. w.g.) Nat. Gas / LPG/Propane	1.7 / 4.5	1.7 / 4.5
High static - in. w.g.	Heating	0.5	0.5
	Cooling	0.5	0.5
Connections in.	Flue connection - in. round	4	4
	Gas pipe size IPS	1/2	1/2
Indoor Blower	Wheel nominal diameter x width - in.	10 x 8	10 x 10
	Motor output - hp	1/2	3/4
	Tons of add-on cooling	1.5 - 3.5	3 - 4
	Air Volume Range - cfm	400 - 1475	780 - 1700
Electrical Data	Voltage	120 volts - 60 hertz - 1 phase	
	Blower motor full load amps	6.1	8.2
	Maximum overcurrent protection	15	15
Shipping Data	lbs. - 1 package	123	142

NOTE - Filters and provisions for mounting are not furnished and must be field provided.

¹ Annual Fuel Utilization Efficiency based on DOE test procedures and according to FTC labeling regulations. Isolated combustion system rating for non-weatherized furnaces.

OPTIONAL ACCESSORIES - ORDER SEPARATELY

	"A" Width Models	"B" Width Models
CABINET		
Downflow Combustible Flooring Base	11M59	11M60
CONTROLS		
iComfort® E30 Smart Wi-Fi Thermostat	20A65	20A65
Remote Outdoor Temperature Sensor	X2658	X2658
Furnace Twinning Kit	16W72	16W72
DOWNFLOW FILTER KITS		
Downflow Filter Kit	51W06	51W07
	No. and Size of filter - in.	(1) 20 x 20 x 1
NIGHT SERVICE KIT		
Night Service Kit	17B59	17B59

GAS HEAT ACCESSORIES

Input	High Altitude Pressure Switch Kit			Natural Gas to LPG/Propane Kit	LPG/Propane to Natural Gas Kit	Natural Gas High Altitude Orifice Kit	LPG/Propane High Altitude Orifice Kit
	0 - 4500 ft.	4501 - 7500 ft.	7501 - 10,000 ft.	0 - 7500 ft.	0 - 7500 ft.	7501 - 10,000 ft.	7501 - 10,000 ft.
070	No Change	91W53	73W36	11K51	77W09	73W37	11K46
090	No Change	91W53	73W36	11K51	77W09	73W37	11K46

HIGH ALTITUDE DERATE

NOTE - Units may be installed at altitudes up to 4500 ft. above sea level without any modifications.

At altitudes above 4500 ft. units must be derated to match information in the shaded area shown below.

NOTE - This is the only permissible derate for these units.

Input	Gas Manifold Pressure (Outlet) in. w.g.											
	0 - 4500 Feet				4501 - 7500 Feet				7501 - 10,000 ft.			
	Natural Gas		LPG/Propane		Natural Gas		LPG/Propane		¹ Natural Gas		LPG/Propane	
	High Fire	Low Fire	High Fire	Low Fire	High Fire	Low Fire	High Fire	Low Fire	High Fire	Low Fire	High Fire	Low Fire
070	3.5	1.7	10	4.5	3.2	1.5	10	4.5	3.5	1.7	10	4.5
090	3.5	1.7	10	4.5	3.0	1.5	10	4.5	3.5	1.7	10	4.5

¹ Natural Gas High Altitude Orifice Kit required.

INSTALLATION CLEARANCES

Vent Type	Type B1	Type C
Sides	0 inches (0 mm)	¹ 0 inches (0 mm)
Rear	0 inches (0 mm)	0 inches (0 mm)
Top	1 inch (25 mm)	1 inch (25 mm)
Front	2-1/4 inches (57 mm)	2-1/4 inches (57 mm)
Front (alcove)	24 inches (610 mm)	24 inches (610 mm)
Front (service)	24 inches (610 mm)	24 inches (610 mm)
Floor	² Combustible	² Combustible
Flue	1 inch (25 mm)	6 inches (152 mm)

NOTE - Air for combustion must conform to the methods outlined in the National Fuel Gas Code (NFPA 54/ANSI-Z223.1).

NOTE - In the U.S. flue sizing must conform to the methods outlined in the current National Fuel Gas Code (NFPA 54/ANSI-Z223.1) or applicable provisions of local building codes.

¹ Left side requires 4 in. clearance if single wall vent is used on 14-1/2 in. "A" width cabinets, and 2 in. clearance on 17-1/2 in. "B" width cabinets.

² Clearance for installation on combustible floor if optional Downflow Combustible Flooring Base is installed between furnace and combustible floor. Not required in add-on cooling applications if installed in accordance with local codes or National Fuel Gas Code ANSI-Z223.1.

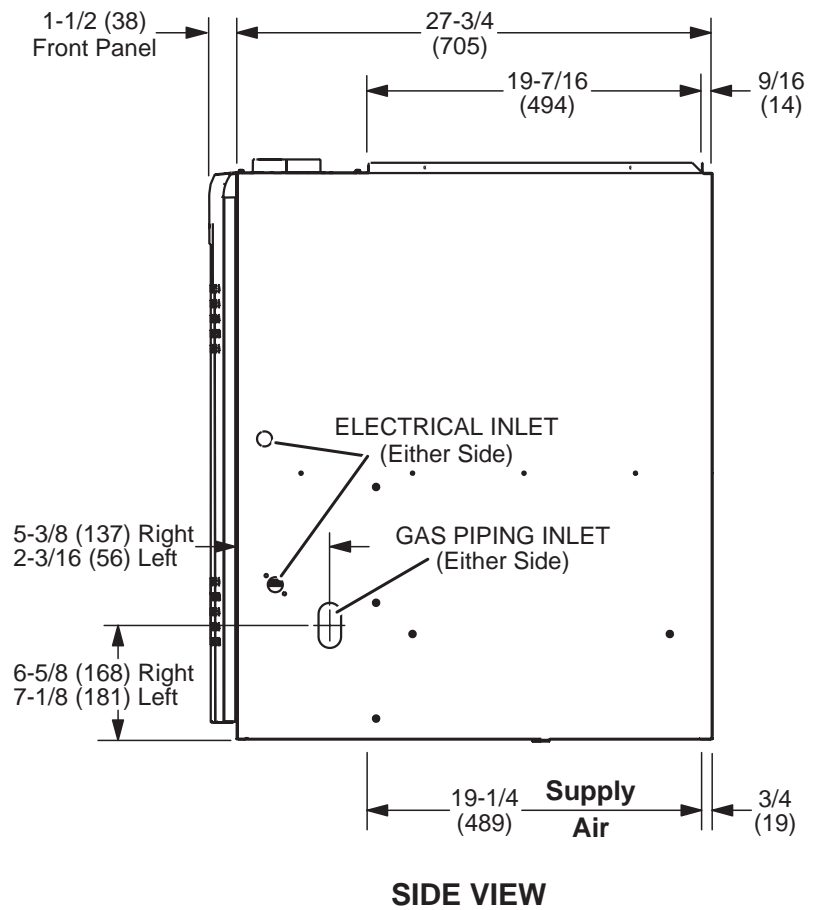
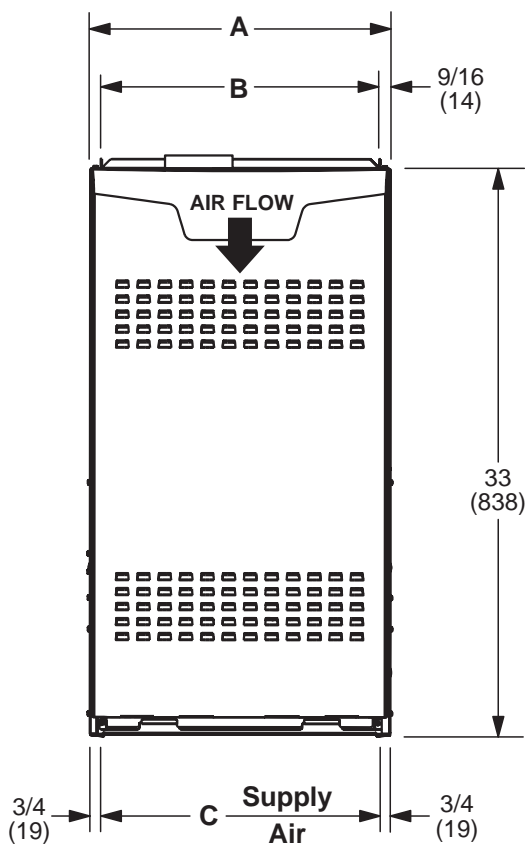
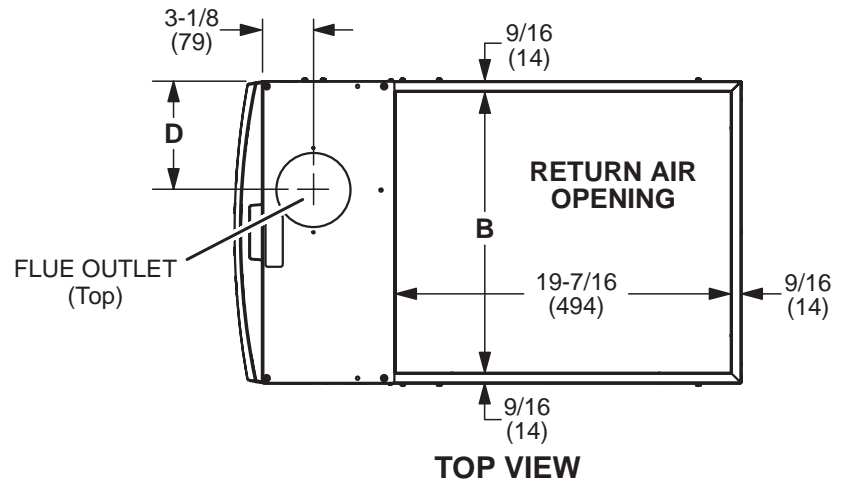

Model No.	A		B		C		D	
	in.	mm	in.	mm	in.	mm	in.	mm
EL280DF070E36A	14-1/2	368	13-3/8	340	13	330	4-3/4	121
EL280DF090E48B	17-1/2	446	16-3/8	416	16	406	6-1/4	159

DOWNFLOW COMBUSTIBLE FLOORING BASE

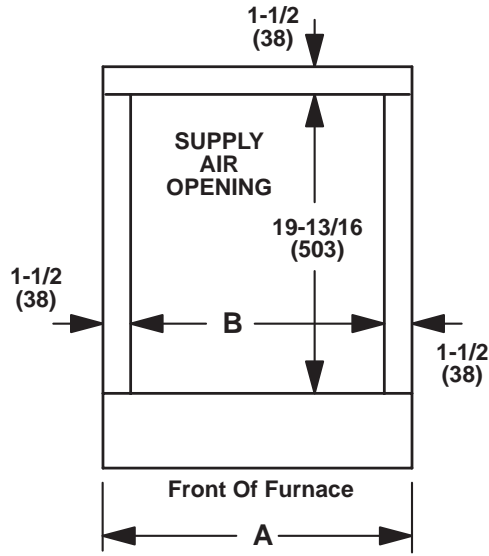
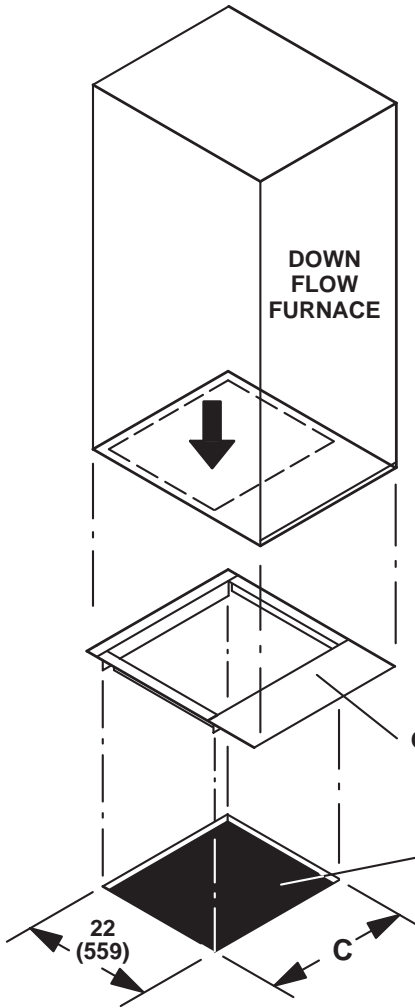

TOP VIEW

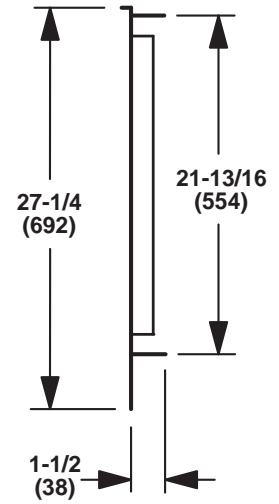

SIDE VIEW

Cabinet Width	Catalog Number	A		B		C	
		in.	mm	in.	mm	in.	mm
A	11M59	16-9/16	421	13-9/16	344	15-3/4	400
B	11M60	19-9/16	497	16-9/16	421	18-3/4	476

DIMENSIONS

OPTIONAL ACCESSORIES

DOWNFLOW FILTER CABINET

**“A” WIDTH FURNACES
(Single Filter)**

**“B” WIDTH FURNACES
(Two Filters)**

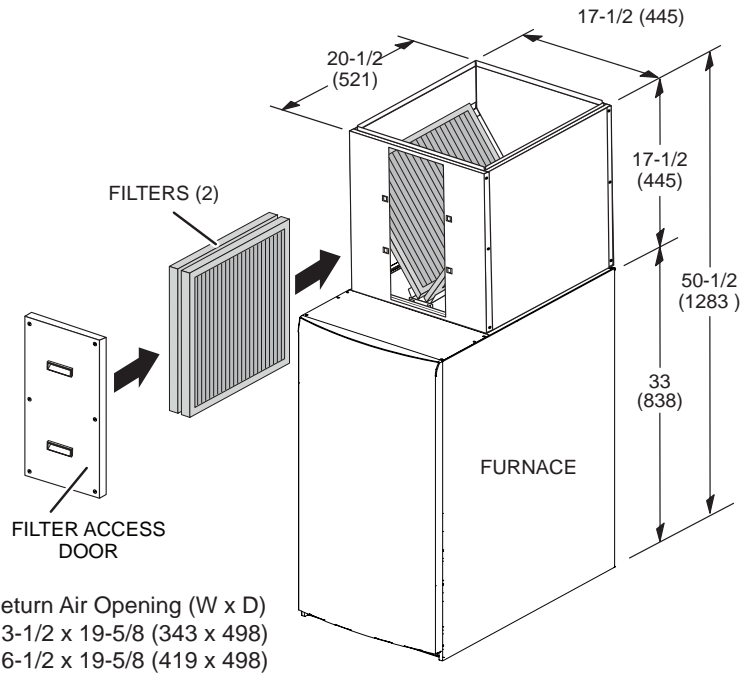
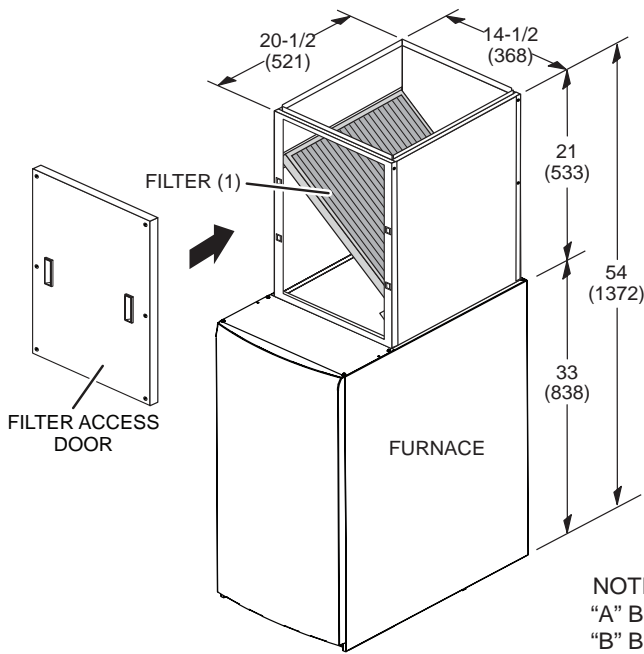

NOTE: Return Air Opening (W x D)
 "A" Box 13-1/2 x 19-5/8 (343 x 498)
 "B" Box 16-1/2 x 19-5/8 (419 x 498)

DIMENSIONS

FURNACE/COIL COMBINED DIMENSIONS

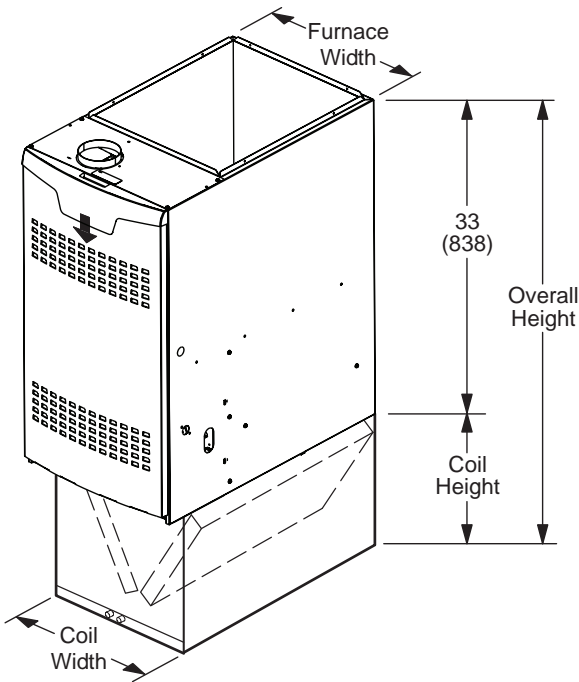

Model Number	Coil Width		Furnace Width		Coil Height		Overall Height	
	in.	mm	in.	mm	in.	mm	in.	mm
CR33-18A-F	17-1/2	446	14-1/2	368	14-1/8	359	47-1/8	1197
CR33-24A-F	17-1/2	446	14-1/2	368	14-1/8	359	47-1/8	1197
CR33-24B-F	17-1/2	446	17-1/2	446	14-1/8	359	47-1/8	1197
CR33-30/36A-F	17-1/2	446	14-1/2	368	16-1/8	410	49-1/8	1248
CR33-30/36B-F	17-1/2	446	17-1/2	446	16-1/8	410	49-1/8	1248
CR33-48B-F	21	533	17-1/2	446	20	508	53	1346

BLOWER DATA

EL280DF070E36A PERFORMANCE (Less Filter)

External Static Pressure in. w.g.	Air Volume / Watts at Various Blower Speeds									
	High (Black)		Medium-High (Brown)		Medium (Blue)		Medium-Low (Yellow)		Low (Red)	
	cfm	Watts	cfm	Watts	cfm	Watts	cfm	Watts	cfm	Watts
0.00	1475	346	1345	269	1190	192	970	109	785	71
0.10	1440	355	1325	276	1165	198	935	114	775	74
0.20	1410	365	1280	287	1135	207	905	120	740	79
0.30	1260	401	1250	296	1095	216	855	129	665	86
0.40	1355	380	1225	305	1060	223	815	134	615	92
0.50	1320	394	1200	315	1035	229	770	140	580	97
0.60	1290	401	1160	324	1005	237	745	149	465	105
0.70	1260	410	1130	333	970	245	700	155	445	108
0.80	1215	399	1095	341	935	254	660	158	400	113

EL280DF090E48B PERFORMANCE (Less Filter)

External Static Pressure in. w.g.	Air Volume / Watts at Various Blower Speeds									
	High (Black)		Medium-High (Brown)		Medium (Blue)		Medium-Low (Yellow)		Low (Red)	
	cfm	Watts	cfm	Watts	cfm	Watts	cfm	Watts	cfm	Watts
0.10	1700	423	1495	293	1380	233	1295	202	1165	156
0.20	1665	436	1455	307	1330	248	1245	211	1110	166
0.30	1620	452	1415	319	1295	257	1195	221	1055	175
0.40	1585	464	1365	328	1225	269	1140	230	985	185
0.50	1560	471	1325	343	1185	277	1090	240	930	193
0.60	1455	475	1275	355	1120	290	1025	252	875	202
0.70	1405	482	1235	365	1075	295	990	259	840	209
0.80	---	---	1160	369	1025	308	925	268	780	217

REVISIONS

Sections	Description of Change
Optional Accessories	E30 catalog number updated.



Visit us at www.lennox.com

For the latest technical information, www.LennoxPros.com

Contact us at 1-800-4-LENNOX

NOTE - Due to Lennox' ongoing commitment to quality, Specifications, Ratings and Dimensions subject to change without notice and without incurring liability. Improper installation, adjustment, alteration, service or maintenance can cause property damage or personal injury. Installation and service must be performed by a qualified installer and servicing agency.

©2020 Lennox Industries, Inc.