



**RESIDENTIAL  
PRODUCT SPECIFICATIONS**

Bulletin No. 210871  
November 2020  
Supersedes July 2020

**ELITE®  
SERIES**



**AFUE - 80%**  
**Input - 44,000 to 110,000 Btuh**  
**Nominal Add-on Cooling - 1.5 to 5 Tons**

**MODEL NUMBER IDENTIFICATION**

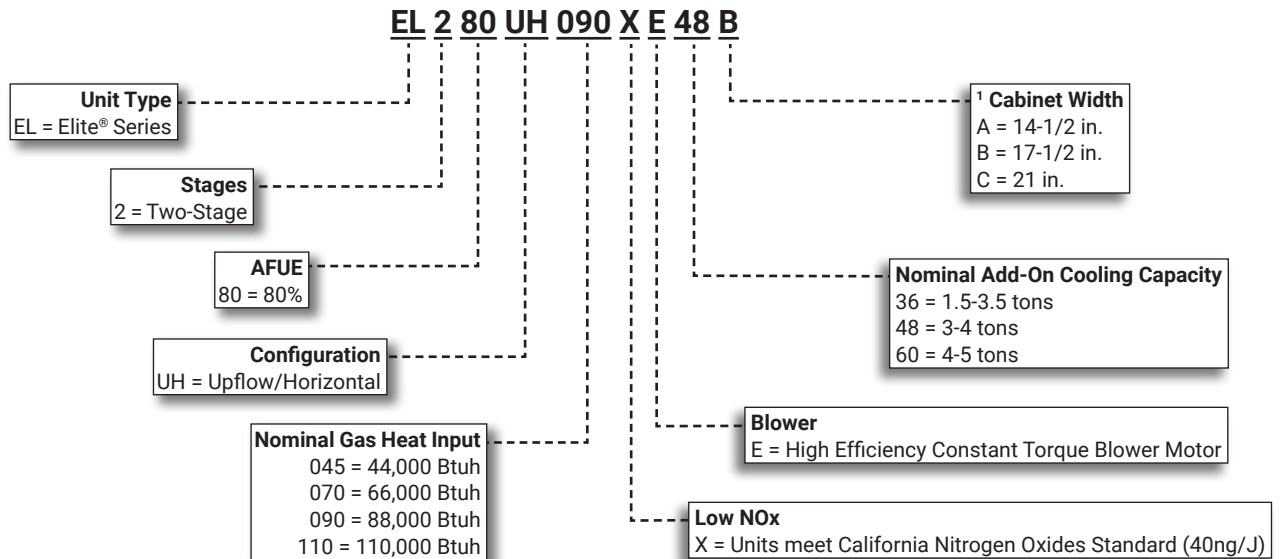

<sup>1</sup> Indoor coils with the same letter designation will physically match the furnace.

## FEATURE HIGHLIGHTS

1. Lennox Duralok™ Heat Exchanger
2. Inshot Burners
3. SureLight® Hot Surface Ignitor
4. Two-Stage Gas Control Valve
5. Two-Speed Combustion Air Inducer
6. Flame Rollout Switches
7. SureLight® Integrated Furnace Control
8. Power Saver™ Constant Torque Blower
9. Insulated Cabinet
10. Safety Interlock Switch
11. Gas Piping And Electrical Inlets

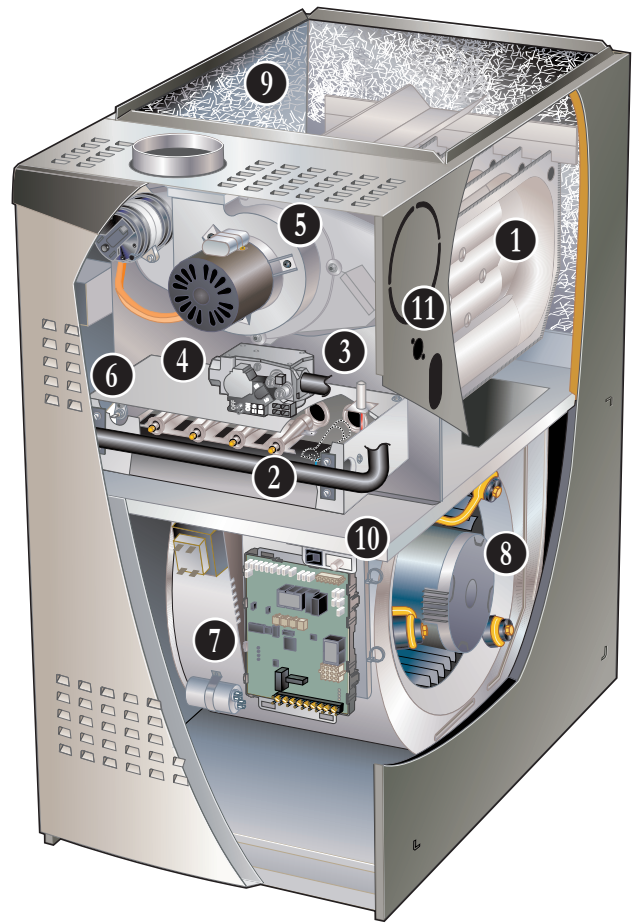

**NOTE - EL280UHE FURNACES ARE NOT AVAILABLE IN CANADA!**

## CONTENTS

Approvals And Warranty . . . . .	3
Blower Data . . . . .	15
Dimensions . . . . .	11
- Unit - Upflow Position . . . . .	11
- Unit - Horizontal Position . . . . .	12
- Optional Accessories . . . . .	13
- Furnace/Coil Combined Dimensions . . . . .	14
Features . . . . .	3
Gas Heat Accessories - Order Separately . . . . .	10
High Altitude Derate . . . . .	10
Installation Clearances . . . . .	7
Model Number Identification . . . . .	1
Optional Accessories - Order Separately . . . . .	10
Specifications . . . . .	8

## APPROVALS AND WARRANTY

### APPROVALS

- AHRI Certified
- CSA International Certified
- Tested and rated according to US DOE test procedures and FTC labeling regulations
- ISO 9001 Registered Manufacturing Quality System
- Blower data from unit tests conducted in Lennox Laboratory air test chamber

#### California Only

- These furnaces **do not meet** the South Coast Air Quality Management District (SCAQMD) Rule 1111 and San Joaquin Valley Air Pollution Control District (SJVAPCD) Rule 4905 NOx emission limit (14 ng/J) and cannot be installed within the SCAQMD and SJVAPCD areas
- All "X" model furnaces are approved by the California Energy Commission and meets California Nitrogen Oxides Standard (NOx) limits of 40 ng/J

### WARRANTY

- Duralok™ Aluminized Steel Heat Exchanger:
  - Limited twenty years in residential applications
  - Limited ten years in non-residential applications
- All other covered components:
  - Limited five years in residential installations
  - Limited one year in non-residential installations

**NOTE** - Refer to Lennox Equipment Limited Warranty certificate included with unit for specific details.

## FEATURES

### APPLICATIONS

- Input capacities of 44,000, 66,000, 88,000 and 110,000 Btuh
- Energy efficiency (AFUE) - 80%
- Compact cabinet for upflow, horizontal-left or horizontal-right applications
- Lennox add-on indoor coils, high-efficiency air cleaners and humidifiers can easily be added to furnace
- Shipped factory assembled with all controls installed and wired
- Ready for installation in upflow or horizontal right-hand position without any modifications

**NOTE** - Horizontal left-hand requires repositioning of pressure switch.

- Removable bottom seal panel shipped in place for side return air is easily removed for bottom/end return air applications
- Each unit factory test operated to ensure proper operation

### HEATING SYSTEM

- 1 Lennox Duralok™ Heat Exchanger Assembly**
  - Heavy gauge aluminized steel heat exchanger
  - Crimped seam clamshell type design
  - Designed for normal expansion and contraction
  - Minimum resistance to air flow

- Laboratory life cycle tested in excess of industry standards
- Compact size of heat permits low overall design of furnace cabinet

- 2 Inshot Burners**

- Aluminized steel inshot burners provide efficient, trouble-free operation
- Burner venturi mixes air and gas in correct proportion for proper combustion
- Burner assembly is removable from the unit as a single component for ease of service

- 3 SureLight® Hot Surface Ignitor**

- Tough, reliable, long-life, trouble-free performance
- Silicon nitride ignitor
- Cemented to steatite block for protection against current leakage
- Ignition leads constructed of nickel plated copper enclosed in high temperature Teflon® insulation for dependable operation

- 4 Two-Stage Gas Control Valve**

- 24 volt redundant combination two-stage gas control valve combines manual shut off switch (On-Off), automatic electric valve (dual) and gas pressure regulation into a compact combination control

## FEATURES

### HEATING SYSTEM (continued)

- 5 Two-Speed Combustion Air Inducer**
- Heavy duty, permanent split capacitor (PSC) two-speed blower prepurges heat exchanger and safely vents flue products
  - Dual pressure switches (low fire/high fire) prove blower operation before allowing gas valve to open
  - Operates only during heating cycle
  - Direct access allows inducer assembly to be rotated 90° clockwise or counterclockwise to facilitate easy vent attachment

- 6 Flame Rollout Switches (2)**
- Factory installed on burner box
  - Switch provides protection from abnormal operating conditions
  - Manual reset

#### Limit Controls

- Primary limit factory installed on vestibule panel
- Secondary limit factory installed on blower housing
- Automatic reset

### Optional Accessories

#### High Altitude Pressure Switch Kit

- Required on most units for proper unit operation at altitudes from 4501 to 10,000 ft.

#### Natural Gas to LPG/Propane Conversion Kit

- Required for field changeover from natural gas to LPG/Propane

#### LPG/Propane to Natural Gas Conversion Kit

- Required for field changeover from LPG/Propane to natural gas

#### Vent Adaptor (Upflow Applications Only)

- Allows venting through a masonry chimney without the need of a flue liner
- Manual reset temperature sensor protects against abnormal operating conditions
- Sensor wiring may be routed from either side of adaptor
- Minimum winter design temperatures:
  - -10°F when used with interior masonry chimneys.
  - +5°F when used with exterior masonry chimneys

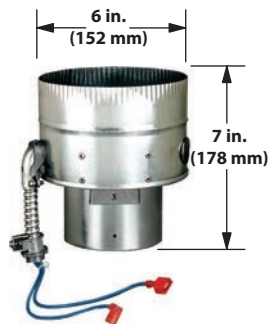

**NOTE** - Refer to Winter Design Temperatures Map on page 7 for application information. Also refer to the installation instructions for detailed information.

### BLOWER

- Direct drive blower
- Statically and dynamically balanced
- Resiliently mounted
- Blower assembly easily removed for servicing

- 7 Power Saver™ Constant Torque Blower Motor**
- DC Brushless Motor
  - High Efficiency Constant Torque
  - ECM (Electronically Commutated Motor)
  - Motor is programmed to provide constant torque at each of the selectable speeds
  - Motor is controlled by the Integrated Furnace Control
  - Blower speeds are easily changed on the integrated furnace control
  - See blower data tables

### CONTROLS

- 8 SureLight® Integrated Two-Stage Furnace Control Board**
- Contains all necessary controls and relays to operate furnace
  - Combustion air inducer is operated by the integrated furnace control
  - Prior to ignition, a pre-purge cycle for 15 seconds is initiated
  - After the main burners are turned off, a post-purge cycle for 5 seconds is run
  - Flame sensor assures safe and reliable operation
  - Should loss of flame occur the integrated furnace control will initiate 4 re-attempts at ignition before locking out unit operation for 60 minutes
  - Watchguard type circuit automatically resets ignition controls after one hour of continuous thermostat demand after unit lockout, eliminating nuisance calls for service
  - Jumper settings for single or two stage thermostat operation
  - Two selectable 2nd stage recognition times (10 and 15 minutes) are available on the board when the furnace is used with a single stage thermostat
  - When used with a two stage thermostat, furnace will only initiate second stage operation with a second stage thermostat demand
  - Fan control consists of adjustable blower timed-off delay (60, 90, 120, 180 seconds - factory setting 90 seconds) and fixed blower timed-on delay (30 seconds heating, 2 seconds cooling)
  - For air-conditioning applications, blower is automatically energized on thermostat demand for cooling
  - Two accessory terminals furnished for additional power supply requirements for 120 volt (less than 1 amp) power humidifiers and powered air cleaners
  - A separate 24V accessory terminal is also provided for low voltage accessories
  - Ignition control has single red LED to indicate status and as an aid in troubleshooting

## FEATURES

### CONTROLS (continued)

#### 24 Volt Transformer

- Furnished and factory installed outside of the control box
- 40VA transformer has circuit breaker wired in series

#### Field Wiring Make-Up Box

- Furnished for line voltage wiring
- Factory installed internally on left side of furnace
- Box may be installed on right side of furnace

### Optional Accessories

#### iComfort® E30 Smart Wi-Fi Thermostat

- Wi-Fi enabled, electronic 7-day, universal, multi-stage, programmable, touchscreen thermostat
- 3 Heat/2 Cool
- Auto-changeover
- Controls dehumidification during cooling mode and humidification during heating mode
- Offers enhanced capabilities including humidification / dehumidification / dewpoint measurement and control, Humiditrol® control, and equipment maintenance reminders
- Easy to read 7 in. color touchscreen (measured diagonally)
- LCD display with backlight shows the current and set temperature, time, inside relative humidity, system status (operating mode and schedules) and outside temperature (optional outdoor sensor required)
- Smooth Setback Recovery starts system early to achieve setpoint at start of program period
- Compressor short-cycle protection (5 minutes)
- Up to four separate schedules are available plus Schedule IQ™
- One-Touch Away Mode - A quick and easy way to set the cooling and heating setpoints while away
- Smart Away™ - Uses geo-fencing technology to determine when the homeowner is within a predetermined distance from the home to operate the system when leaving, away and arriving
- Wi-Fi remote monitoring and adjustment through a home wireless network for desktop PCs, laptops and apps for smartphones or tablets
- Smart home automation compatible with Apple HomeKit™, Amazon Alexa®, Google Assistant and IFTTT
- Service Dashboard features online real-time monitoring of installed iComfort® thermostats
- High Definition Color Display with Subbase, Smart Hub Controller, wallplate (for retrofit installations) furnished for easy installation
- See the iComfort® E30 Smart Wi-Fi Thermostat Product Specifications bulletin for more information



#### Remote Outdoor Temperature Sensor

- iComfort® E30 Smart Thermostat
- When installed outdoors, sensor allows thermostat to display outdoor temperature



**NOTE** - Sensor is required for Enhanced Dehumidification Control (EDA) applications.

**NOTE** - The outdoor sensor is furnished as standard with iComfort® Communicating outdoor units, optional for conventional units.

#### Thermostat

- Thermostat is not furnished with unit
- See Lennox Price Book for selection

#### Furnace Twinning Kit

- Required to operate two furnaces simultaneously.
- Kit consists of twinning relays, quick connect terminals and mounting hardware
- Used for two-stage heating/single-stage cooling with either a single-stage or two-stage thermostat

#### Night Service Kit

- Contains most commonly used service parts
- Furnace control
- Gas valve
- Ignitor
- Transformer
- Flame sensor
- Service manual

#### CABINET

- Low-profile, narrow width cabinet allows easy installation
- Heavy-gauge, cold rolled steel construction
- Pre-painted finish
- Flue outlet on top of cabinet for upflow applications, can be relocated to either side of cabinet for horizontal applications
- Flanges provided on supply air opening for ease of plenum connection or alignment with indoor coil
- 9 • Insulated with foil faced insulation on sides and back of heating compartment and mat faced insulation in blower compartment
- Sealed blower compartment
- Inner blower compartment access panel seals blower compartment from air leakage
- Cabinet door can be removed without any tools
- Complete service access
- 10 • Safety interlock switch automatically shuts off power to unit when inner blower compartment access panel is removed
- 11 • Gas piping and electrical inlets are provided in both sides of cabinet

## FEATURES

### **CABINET (continued)**

#### **Low Leakage Cabinet**

- All models have less than 2% air leakage and meet ANSI/ASHRAE Standard 193-2010 "Method of Test for Determining the Air Tightness of HVAC Equipment"

#### **Bottom/Side Return Air Entry:**

- Upflow/horizontal with bottom return air entry:
  - Remove furnished bottom seal panel from cabinet
- Upflow only with side return-air entry:
  - Corners are marked on either side of cabinet for return air cut-out
- See dimension drawings

**NOTE** - 60C size units that require air volumes over 1800 cfm must have one of the following:

- Single side return air and Optional Return Air Base with transition that must accommodate required 20 x 25 x 1 inch air filter to maintain proper velocity
- Bottom return air
- Return air from both sides
- Bottom and one side return air
- See Blower Data Tables for additional information

#### **Coil Match-Up**

- All furnaces exactly match Lennox cased upflow indoor coils and horizontal indoor coils with same letter designation (A, B, C, D) in model number
- No adaptor required
- Engaging holes furnished on cabinet for alignment.
- Lennox uncased coils match furnaces without any overhang but require an optional adaptor base or field fabricated transition to match furnace opening
- See coil bulletin for additional information
- 

### **Optional Accessories**

#### **Horizontal Suspension Kit**

- Provides suspension of unit and indoor coil in horizontal applications.
- Allows complete service access.
- Consists of corner mounted hanging brackets with vibration isolators, return air end support rail and hardware for assembly.
- Metal hanging straps must be field provided.

#### **Return Air Base**

- A field fabricated transition or Return Air Base is required when using an IAQ product higher than 14-3/16 in. installed next to the unit and serviced from the front. IAQ products higher than 20 in. require a field fabricated transition.
- Base must be used for 60C models with air volumes over 1800 cfm in upflow applications when only one side return is required.
- Cabinet is shipped flat for easy field assembly and is pre-painted steel to match the furnace. See Dimension Drawing.

#### **High Performance Economizer (Commercial Applications Only)**

- Designed for applications requiring outdoor air to be utilized in a commercial HVAC system. Allows the entry of fresh outdoor air for free cooling, reducing the requirement for mechanical cooling.
- Heavy gauge galvanized steel cabinet lined with thick fiberglass insulation.
- Mixed air sensor, outdoor air sensor and 24VAC transformer furnished.
- Approved for California Title 24 building standards.
- ASHRAE 90.1-2010 compliant.
- See separate Product Specifications bulletin for additional information and available control and sensor options.
- **FILTER (not furnished)**
- Filter and provisions for external mounting must be field provided.

### **Optional Accessories**

#### **Air Filter and Rack Kit for Horizontal Return Air (End) Applications**

- Washable or vacuum cleanable polyurethane frame type filter and external end return air rack available for field installation.
- Rack has filter door for easy filter servicing.
- Flanges on rack allow easy duct connection.
- See dimension drawing.

#### **Air Filter and Rack Kit for Upflow Side Return Air**

- Applications - Not for use with Return Air Base
- Washable or vacuum cleanable polyurethane frame type filter and external side return air rack available for field installation.
- Available in single and ten pack kits.
- Rack has filter door for easy filter servicing.
- Flanges on rack allow easy duct connection.
- Field installs on either side of unit cabinet. See dimension drawing.

## 99% WINTER DESIGN TEMPERATURES FOR THE CONTIGUOUS UNITED STATES



This map is a necessarily generalized guide to temperatures in the contiguous United States. Temperatures shown for areas such as mountainous regions and large urban centers may not be accurate. The data used to develop this map was taken from the 1993 ASHRAE Fundamentals Handbook (Chapter 24, Table 1: Climate Conditions for the United States).

Reprinted with permission from NFPA 54: National Fuel Gas Code 1999, National Fire Protection Association, Quincy, MA 02269. This reprinted material is not the complete and official position of the National Fire Protection Association on the referenced subject, which is represented only by the standard in its entirety.

## INSTALLATION CLEARANCES

### UPFLOW POSITION

Vent Type	Type B1	Type C
Sides	0 (0)	<sup>1</sup> 0 (0)
Rear	0 (0)	0 (0)
Top	1 (25)	1 (25)
Front	2-1/4 (57)	2-1/4 (57)
Front (service/alcove)	24 (610)	24 (610)
Floor	Combustible	Combustible
Flue	1 (25)	6 (152)

NOTE – Air for combustion must conform to the methods outlined in the National Fuel Gas Code (NFPA 54/ANSI-Z223.1).

NOTE – In the U.S. flue sizing must conform to the methods outlined in the current National Fuel Gas Code (NFPA 54/ANSI-Z223.1) or applicable provisions of local building codes.

<sup>1</sup> Left side requires 4 in. if single wall vent is used on 14-1/2 in. "A" width cabinets, 2 in. on 17-1/2 in. "B" width cabinets.

### HORIZONTAL POSITION

Vent Type	Type B1	Type C
End	<sup>1</sup> 2	<sup>1</sup> 2
Rear	0 (0)	0 (0)
Top	<sup>1</sup> 0 (0)	<sup>1</sup> 0 (0)
Front	2-1/4 (57)	2-1/4 (57)
Front (service)	24 (610)	24 (610)
Floor	Combustible	Combustible
Flue	1 (25)	6 (152)

NOTE – Air for combustion must conform to the methods outlined in the National Fuel Gas Code (NFPA 54/ANSI-Z223.1).

NOTE – In the U.S. flue sizing must conform to the methods outlined in the current National Fuel Gas Code (NFPA 54/ANSI-Z223.1) or applicable provisions of local building codes.

<sup>1</sup> Line contact installation permissible between jacket top or sides and building joists.

## SPECIFICATIONS

Gas Heating Performance	Model No.	EL280UH045E36A	EL280UH070E36A
	Model No. - Low NOx	- - -	EL280UH070XE36A
	<sup>1</sup> AFUE	80%	80%
<b>High Fire</b>	Input - Btuh	44,000	66,000
	Output - Btuh	35,000	53,000
	Temperature rise range - °F	30 - 60	30 - 60
	Gas Manifold Pressure (in. w.g.) Nat. Gas / LPG/Propane	3.5 / 10.0	3.5 / 10.0
<b>Low Fire</b>	Input - Btuh	29,000	43,000
	Output - Btuh	23,000	35,000
	Temperature rise range - °F	20 - 50	20 - 50
	Gas Manifold Pressure (in. w.g.) Nat. Gas / LPG/Propane	1.7 / 4.5	1.7 / 4.5
<b>High static - in. w.g.</b>	Heating	0.5	0.5
	Cooling	0.5	0.5
<b>Connections in.</b>	Flue connection - in. round	4	4
	Gas pipe size IPS	1/2	1/2
<b>Indoor Blower</b>	Wheel nominal diameter x width - in.	10 x 8	10 x 8
	Motor output - hp	1/2	1/2
	Tons of add-on cooling	1.5 - 3.5	2 - 3.5
	Air Volume Range - cfm	250 - 1500	350 - 1375
<b>Electrical Data</b>	Voltage	120 volts - 60 hertz - 1 phase	
	Blower motor full load amps	6.1	6.1
	Maximum overcurrent protection	15	15
<b>Shipping Data</b>	lbs. - 1 package	111	121

NOTE - Filters and provisions for mounting are not furnished and must be field provided.

<sup>1</sup> Annual Fuel Utilization Efficiency based on DOE test procedures and according to FTC labeling regulations. Isolated combustion system rating for non-weatherized furnaces.

## SPECIFICATIONS

Gas Heating Performance	Model No.	EL280UH090E36B	EL280UH090E48B
	Model No. - Low NOx	- - -	EL280UH090XE48B
	<sup>1</sup> AFUE	80%	80%
<b>High Fire</b>	Input - Btuh	88,000	88,000
	Output - Btuh	70,000	69,000
	Temperature rise range - °F	35 - 65	30 - 60
	Gas Manifold Pressure (in. w.g.) Nat. Gas / LPG/Propane	3.5 / 10.0	3.5 / 10.0
<b>Low Fire</b>	Input - Btuh	57,000	57,000
	Output - Btuh	46,000	46,000
	Temperature rise range - °F	25 - 55	20 - 50
	Gas Manifold Pressure (in. w.g.) Nat. Gas / LPG/Propane	1.7 / 4.5	1.7 / 4.5
<b>High static - in. w.g.</b>	Heating	0.5	0.5
	Cooling	0.5	0.5
<b>Connections in.</b>	Flue connection - in. round	4	4
	Gas pipe size IPS	1/2	1/2
<b>Indoor Blower</b>	Wheel nominal diameter x width - in.	10 x 9	10 x 10
	Motor output - hp	1/2	3/4
	Tons of add-on cooling	2 - 3.5	3 - 4
	Air Volume Range - cfm	350 - 1600	765 - 1800
<b>Electrical Data</b>	Voltage	120 volts - 60 hertz - 1 phase	
	Blower motor full load amps	6.1	8.2
	Maximum overcurrent protection	15	15
<b>Shipping Data</b>	lbs. - 1 package	136	140

NOTE - Filters and provisions for mounting are not furnished and must be field provided.

<sup>1</sup> Annual Fuel Utilization Efficiency based on DOE test procedures and according to FTC labeling regulations. Isolated combustion system rating for non-weatherized furnaces.



## SPECIFICATIONS

Gas		Model No.	EL280UH110E48C	EL280UH110E60C
<b>Heating Performance</b>	<b>Model No. - Low NOx</b>		- - -	<b>EL280UH110XE60C</b>
	<sup>1</sup> AFUE		80%	80%
<b>High Fire</b>	Input - Btuh		110,000	110,000
	Output - Btuh		86,000	87,000
	Temperature rise range - °F		35 - 65	30 - 60
	Gas Manifold Pressure (in. w.g.)		3.5 / 10.0	3.5 / 10.0
	Nat. Gas / LPG/Propane			
<b>Low Fire</b>	Input - Btuh		72,000	72,000
	Output - Btuh		58,000	58,000
	Temperature rise range - °F		25 - 55	20 - 50
	Gas Manifold Pressure (in. w.g.)		1.7 / 4.5	1.7 / 4.5
	Nat. Gas / LPG/Propane			
<b>High static - in. w.g.</b>	Heating		0.5	0.5
	Cooling		0.5	0.5
<b>Connections in.</b>	Flue connection – in. round		4	4
	Gas pipe size IPS		1/2	1/2
<b>Indoor Blower</b>	Wheel nominal diameter x width - in.		10 x 10	11-1/2 x 10
	Motor output - hp		3/4	1
	Tons of add-on cooling		3 - 4	4 - 5
	Air Volume Range - cfm		865 - 1780	1100 - 2200
<b>Electrical Data</b>	Voltage		120 volts - 60 hertz - 1 phase	
	Blower motor full load amps		8.2	10
	Maximum overcurrent protection		15	15
<b>Shipping Data</b>	lbs. - 1 package		152	156

NOTE - Filters and provisions for mounting are not furnished and must be field provided.

<sup>1</sup> Annual Fuel Utilization Efficiency based on DOE test procedures and according to FTC labeling regulations. Isolated combustion system rating for non-weatherized furnaces.

## OPTIONAL ACCESSORIES - ORDER SEPARATELY

		"A" Width Models	"B" Width Models	"C" Width Models	
<b>CABINET</b>					
Horizontal Suspension Kit - Horizontal only		51W10	51W10	51W10	
Return Air Base - Upflow only		65W75	50W98	50W99	
High Performance Economizer (Commercial only)		10U53	10U53	10U53	
<b>CONTROLS</b>					
iComfort® E30 Smart Wi-Fi Thermostat		20A65	20A65	20A65	
Remote Outdoor Temperature Sensor		X2658	X2658	X2658	
Furnace Twinning Kit		16W72	16W72	16W72	
<b>FILTERS</b>					
1 Air Filter and Rack Kit	Horizontal (end)		87L95	87L96	87L97
		Size of filter - in.	14 x 25 x 1	18 x 25 x 1	20 x 25 x 1
	Side Return	Single	44J22	44J22	44J22
		Ten Pack	66K63	66K63	66K63
		Size of filter - in.	16 x 25 x 1	16 x 25 x 1	16 x 25 x 1
<b>NIGHT SERVICE KIT</b>					
Night Service Kit		17B59	17B59	17B59	
<b>VENTING</b>					
Vent Adaptor – 6 in. conn. size upflow applications only		18M79	18M79	18M79	

<sup>1</sup> Cleanable polyurethane, frame-type filter.

## GAS HEAT ACCESSORIES - ORDER SEPARATELY

Input	High Altitude Pressure Switch Kit			Natural Gas to LPG/Propane Kit	LPG/Propane to Natural Gas Kit	Natural Gas High Altitude Orifice Kit	LPG/Propane High Altitude Orifice Kit
	0 - 4500 ft.	4501 - 7500 ft.	7501 - 10,000 ft.	0 - 7500 ft.	0 - 7500 ft.	7501 - 10,000 ft.	7501 - 10,000 ft.
045	No Change	91W53	73W35	11K51	77W09	73W37	11K46
070	No Change	91W53	73W35	11K51	77W09	73W37	11K46
090	No Change	91W53	73W35	11K51	77W09	73W37	11K46
110	No Change	91W53	73W35	11K51	77W09	73W37	11K46

## HIGH ALTITUDE DERATE

NOTE - Units may be installed at altitudes up to 4500 ft. above sea level without any modifications.

At altitudes above 4500 ft. units must be derated to match information in the shaded area shown below.

NOTE - This is the only permissible derate for these units.

Input	Gas Manifold Pressure (Outlet) in. w.g.											
	0 - 4500 Feet				4501 - 7500 Feet				7501 - 10,000 ft.			
	Natural Gas		LPG/Propane		Natural Gas		LPG/Propane		<sup>1</sup> Natural Gas		LPG/Propane	
	High Fire	Low Fire	High Fire	Low Fire	High Fire	Low Fire	High Fire	Low Fire	High Fire	Low Fire	High Fire	Low Fire
045	3.5	1.7	10	4.5	3.2	1.5	10	4.5	3.5	1.7	10	4.5
070	3.5	1.7	10	4.5	3.2	1.5	10	4.5	3.5	1.7	10	4.5
090	3.5	1.7	10	4.5	3.2	1.5	10	4.5	3.5	1.7	10	4.5
110	3.5	1.7	10	4.5	3.2	1.5	10	4.5	3.5	1.7	10	4.5

<sup>1</sup> Natural Gas High Altitude Orifice Kit required.

# DIMENSIONS

# UNIT - UPFLOW POSITION

- <sup>1</sup> NOTE - 60C size units that require air volumes over 1800 cfm must have one of the following:
1. Single side return air and Optional Return Air Base with transition that must accommodate required 20 x 25 x 1 inch (508 x 635 x 25 mm) air filter to maintain proper velocity.
  2. Bottom return air.
  3. Return air from both sides.
  4. Bottom and one side return air.
- See Blower Performance Tables for additional information.

- <sup>2</sup> Flue outlet may be horizontal but furnace must be vented vertically
- <sup>3</sup> Optional External Side Return Air Filter Kit is not for use with the optional Return Air Base.

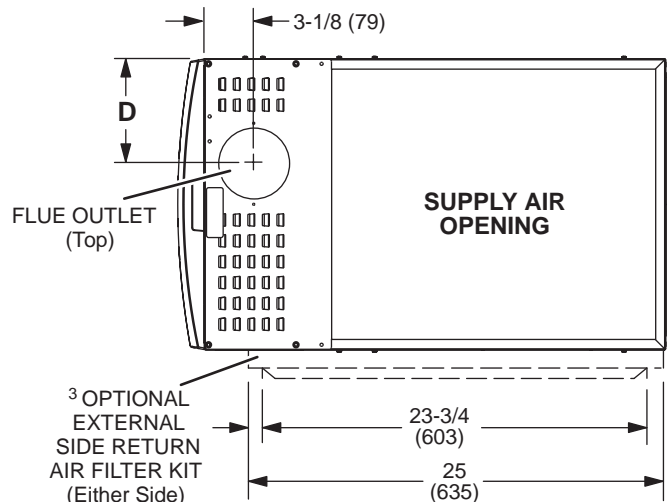

**TOP VIEW**

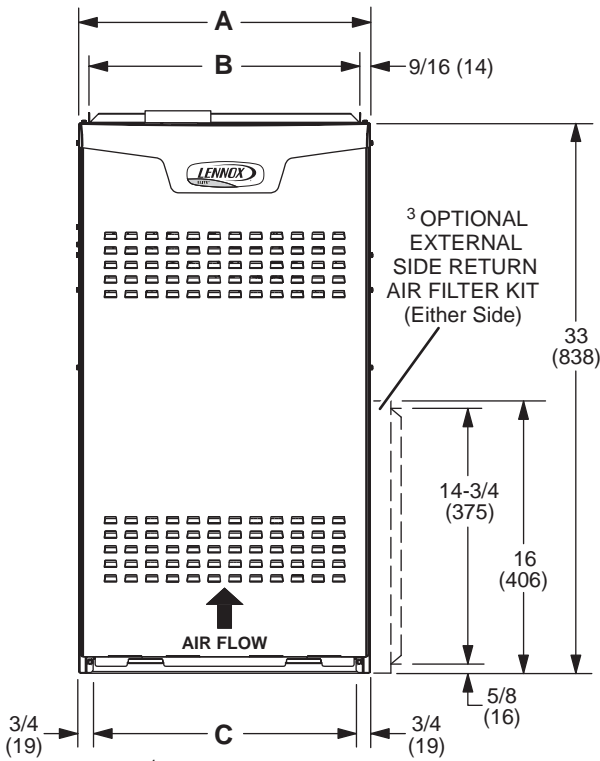

<sup>1</sup> Bottom Return Air Opening  
**FRONT VIEW**

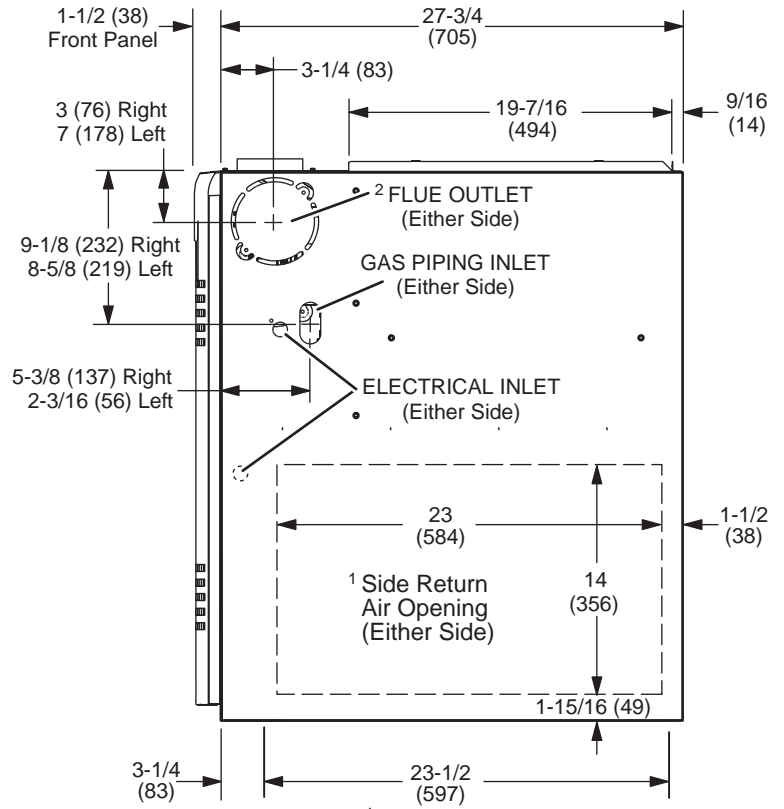

<sup>1</sup> Bottom Return Air Opening  
**SIDE VIEW**

Model No.	A		B		C		D	
	in.	mm	in.	mm	in.	mm	in.	mm
EL280UH045E36A EL280UH070E36A	14-1/2	368	13-3/8	340	13	330	4-3/4	121
EL280UH090E36B EL280UH090E48B	17-1/2	446	16-3/8	416	16	406	6-1/4	159
EL280UH110E48C EL280UH110E60C	21	533	19-7/8	504	19-1/2	495	8	203

**LEFT-HAND AIR DISCHARGE**

<sup>1</sup> Flue outlet may be from end but furnace must be vented vertically

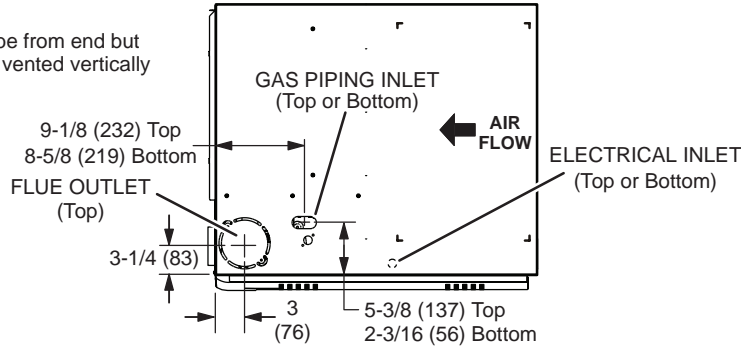

**TOP VIEW**

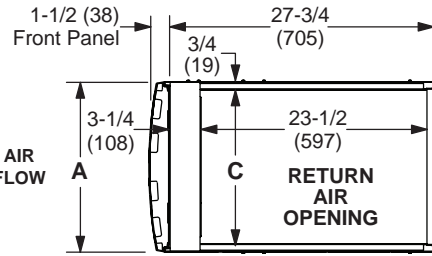
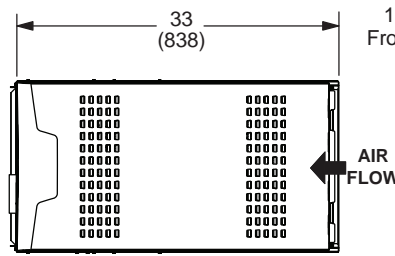
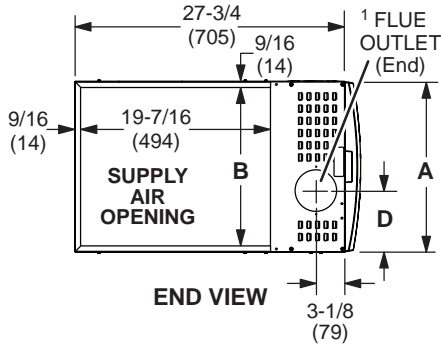

**RIGHT-HAND AIR DISCHARGE**

<sup>1</sup> Flue outlet may be horizontal but furnace must be vented vertically

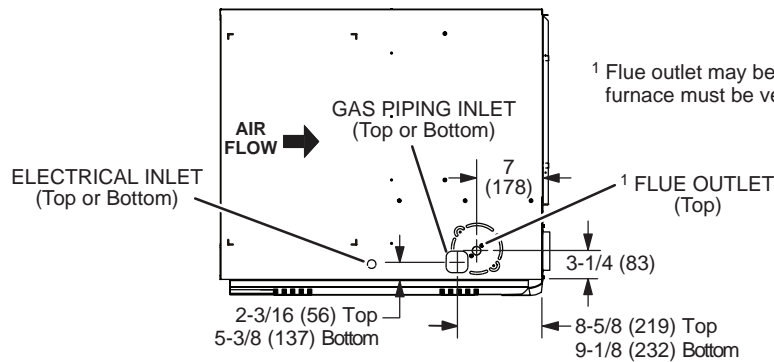

**TOP VIEW**

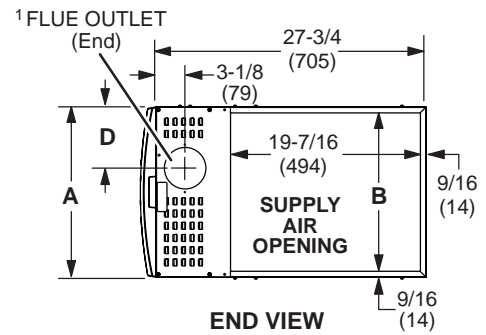
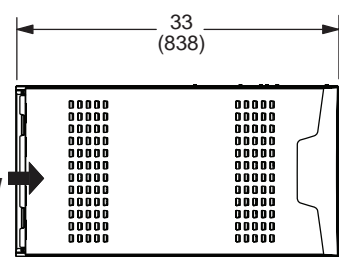
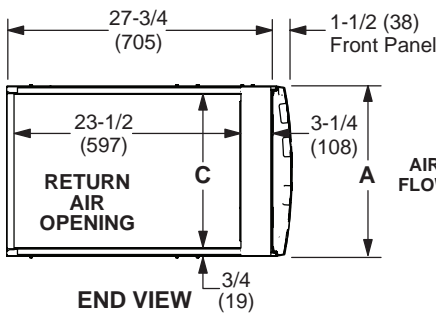

Model No.	A		B		C		D	
	in.	mm	in.	mm	in.	mm	in.	mm
EL280UH045E36A EL280UH070E36A	14-1/2	368	13-3/8	340	13	330	4-3/4	121
EL280UH090E36B EL280UH090E48B	17-1/2	446	16-3/8	416	16	406	6-1/4	159
EL280UH110E48C EL280UH110E60C	21	533	19-7/8	504	19-1/2	495	8	203

**HORIZONTAL (END) FILTER KIT**

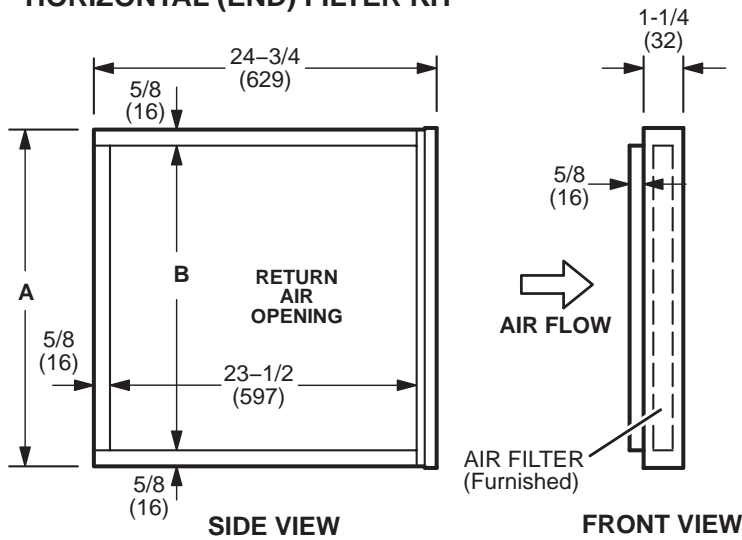

Furnace Cabinet Width	Catalog Number	A		B	
		in.	mm	in.	mm
A	87L95	14	356	12-3/4	324
B	87L96	18	457	16-3/4	425
C	87L97	21	533	18-3/4	476

**Optional Return Air Base  
(Upflow Applications Only - For use with A, B and C width cabinets)**

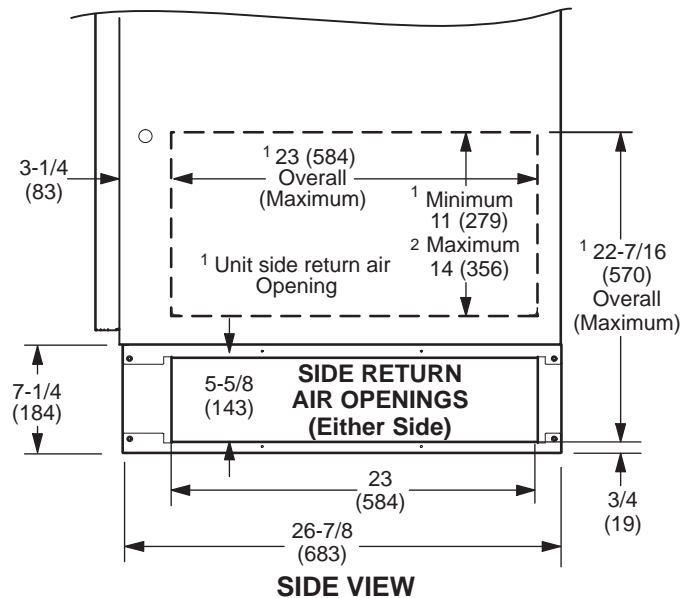
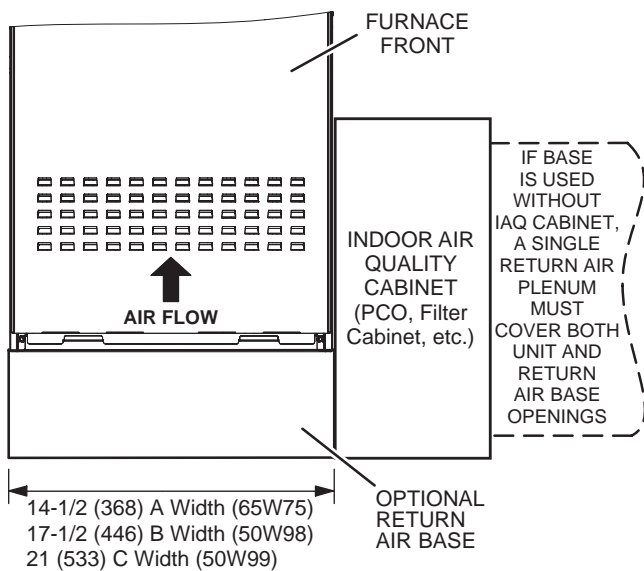

**NOTE- Optional Side Return Air Filter Kits are not for use with Optional Return Air Base.**

- <sup>1</sup> Both the unit return air opening and the base return air opening must be covered by a single plenum or IAQ cabinet. Minimum unit side return air opening dimensions for units requiring 1800 cfm or more of air (W x H): 23 x 11 in. (584 x 279 mm). The opening can be cut as needed to accommodate plenum or IAQ cabinet while maintaining dimensions shown. Side return air openings must be cut in the field. There are cutting guides stenciled on the cabinet for the side return air opening. The size of the opening must not extend beyond the markings on the furnace cabinet.
- <sup>2</sup> To minimize pressure drop, the largest opening height possible, up to 14 in. (356 mm), is preferred.

**UPFLOW POSITION**

Model No	C35/CX35 Cased				C35 Uncased			
	A		B		A		B	
	in.	mm	in.	mm	in.	mm	in.	mm
C35/CX35-18/24A C35/CX35-18/24B	16-1/2	419	49-1/2	1257	14-1/8	359	47-1/8	1197
C35/CX35-24A C35/CX35-24B	18-1/2	470	51-1/2	1308	16-3/8	416	49-3/8	1254
---	20-1/2	521	53-1/2	1359	---	---	---	---
C35/CX35-30A C35/CX35-30B	22-1/2	572	55-1/2	1410	20-3/4	527	53-3/4	1365
C35/CX35-30/36A C35/CX35-30/36B C35/CX35-30/36C	24-1/2	622	57-1/2	1461	22-1/4	565	55-1/4	1403
C35/CX35-36A C35/CX35-36B	24-1/2	622	57-1/2	1461	22-3/8	568	55-3/8	1407
---	24-1/2	622	57-1/2	1461	---	---	---	---
C35/CX35-48B C35/CX35-48C	27-1/2	699	60-1/2	1537	26-1/4	667	59-1/4	1505
---	24-1/2	622	57-1/2	1461	---	---	---	---
C35/CX35-49C	29-1/2	749	62-1/2	1588	28-1/2	724	61-1/2	1562
C35/CX35-50/60C	27-1/2	699	60-1/2	1537	25-7/8	657	58-7/8	1495
CX35-60C	31-1/2	800	64-1/2	1638	30-5/8	778	63-5/8	1616

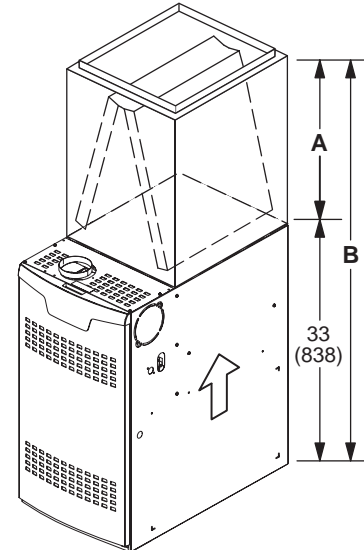

**HORIZONTAL POSITION**

Model No.		A		B	
		in.	mm	in.	mm
<b>CH35</b>					
CH35-18A, CH35-24A, CH35-24B, CH35-30B,	CH35-36A, CH35-36B, CH35-36C, CH35-42C, CH35-48C	26-1/2	673	59-1/2	1511
CH35-30A, CH35-42B, CH35-48B,	CH35-51C	31-1/2	880	64-1/2	1638
<b>CHX35</b>					
CHX35-18A, CHX35-24A, CHX35-24B, CHX35-30B,	CHX35-36A, CHX35-36B, CHX35-36C, CHX35-42C, CHX35-48C	26-1/2	673	59-1/2	1511
CHX35-30A, CHX35-42B, CHX35-48B,	CHX35-51/61C	31-1/2	880	64-1/2	1638

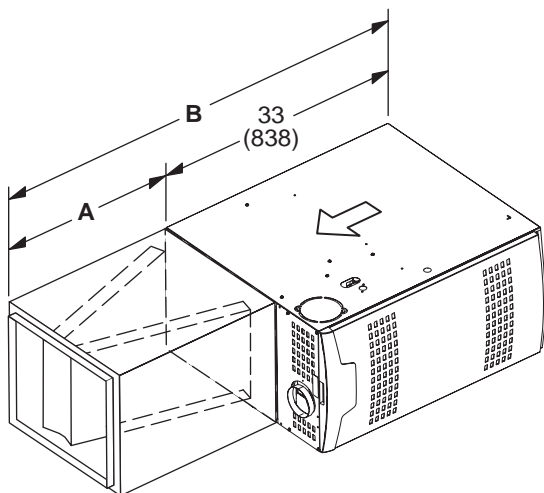

## BLOWER DATA

### EL280UH045E36A PERFORMANCE (Less Filter)

External Static Pressure in. w.g.	Air Volume / Watts at Various Blower Speeds									
	High (Black)		Medium-High (Brown)		Medium (Blue)		Medium-Low (Yellow)		Low (Red)	
	cfm	Watts	cfm	Watts	cfm	Watts	cfm	Watts	cfm	Watts
0.00	1500	300	1220	175	1050	114	850	65	800	48
0.10	1485	311	1200	179	1025	118	810	68	790	50
0.20	1460	323	1170	188	980	125	725	73	580	53
0.30	1420	334	1140	195	930	133	670	76	455	54
0.40	1395	343	1095	203	890	138	600	86	375	60
0.50	1355	355	1050	212	840	149	550	93	325	64
0.60	1325	368	1020	222	790	158	495	96	275	67
0.70	1290	369	980	228	745	164	420	103	238	69
0.80	1260	381	945	238	700	172	380	107	---	---

### EL280UH070E36A PERFORMANCE (Less Filter)

External Static Pressure in. w.g.	Air Volume / Watts at Various Blower Speeds									
	High (Black)		Medium-High (Brown)		Medium (Blue)		Medium-Low (Yellow)		Low (Red)	
	cfm	Watts	cfm	Watts	cfm	Watts	cfm	Watts	cfm	Watts
0.00	1375	340	1350	240	1110	190	970	93	780	50
0.10	1350	346	1325	254	1100	194	940	104	725	57
0.20	1330	346	1310	264	1080	200	895	113	680	64
0.30	1315	353	1280	272	1060	204	860	118	610	70
0.40	1300	368	1250	283	1040	212	810	125	550	76
0.50	1285	369	1220	293	1010	222	765	132	510	78
0.60	1260	384	1190	301	975	227	725	140	460	83
0.70	1240	391	1150	314	950	236	680	147	400	89
0.80	1210	399	1120	319	915	244	640	152	355	95

### EL280UH090E36B PERFORMANCE (Less Filter)

External Static Pressure in. w.g.	Air Volume / Watts at Various Blower Speeds									
	High (Black)		Medium-High (Brown)		Medium (Blue)		Medium-Low (Yellow)		Low (Red)	
	cfm	Watts	cfm	Watts	cfm	Watts	cfm	Watts	cfm	Watts
0.00	1605	313	1475	240	1320	173	1,050	99	865	60
0.10	1565	323	1430	251	1270	185	995	108	800	68
0.20	1515	334	1380	264	1225	196	935	115	730	76
0.30	1475	347	1340	275	1170	207	870	124	645	83
0.40	1435	360	1300	285	1120	215	805	133	550	91
0.50	1395	369	1250	295	1065	225	715	140	470	98
0.60	1355	378	1205	307	1010	235	655	147	395	101
0.70	1305	391	1160	318	935	246	560	156	345	107
0.80	1265	404	1105	329	875	254	510	162	300	112

## BLOWER DATA

### EL280UH090E48B PERFORMANCE (Less Filter)

External Static Pressure in. w.g.	Air Volume / Watts at Various Blower Speeds									
	High (Black)		Medium-High (Brown)		Medium (Blue)		Medium-Low (Yellow)		Low (Red)	
	cfm	Watts	cfm	Watts	cfm	Watts	cfm	Watts	cfm	Watts
0.00	1800	370	1555	260	1425	207	1370	172	1240	131
0.10	1765	381	1525	272	1390	218	1320	184	1190	144
0.20	1725	397	1485	283	1350	229	1255	195	1130	157
0.30	1685	416	1450	296	1310	241	1205	206	1075	165
0.40	1635	425	1390	312	1260	250	1165	217	1015	174
0.50	1600	438	1350	322	1205	263	1100	230	955	185
0.60	1560	453	1300	332	1140	270	1050	239	905	193
0.70	1520	467	1255	344	1110	284	1000	249	840	202
0.80	1470	474	1215	352	1050	294	935	258	765	211

### EL280UH110E48C PERFORMANCE (Less Filter)

External Static Pressure in. w.g.	Air Volume / Watts at Various Blower Speeds									
	High (Black)		Medium-High (Brown)		Medium (Blue)		Medium-Low (Yellow)		Low (Red)	
	cfm	Watts	cfm	Watts	cfm	Watts	cfm	Watts	cfm	Watts
0.00	1780	349	1570	248	1465	190	1370	169	1250	131
0.10	1750	365	1540	260	1420	205	1330	177	1205	140
0.20	1720	382	1500	271	1365	220	1280	187	1155	150
0.30	1675	397	1460	279	1330	228	1250	197	1110	159
0.40	1645	407	1415	291	1290	241	1200	211	1070	166
0.50	1605	424	1395	307	1250	249	1165	219	1015	177
0.60	1580	432	1345	316	1205	258	1105	228	960	186
0.70	1565	448	1300	328	1165	271	1060	237	915	194
0.80	1525	449	1270	339	1125	283	1025	246	865	203

### EL280UH110E60C PERFORMANCE (Less Filter)

External Static Pressure in. w.g.	Air Volume / Watts at Different Blower Speeds																			
	Bottom Return Air, Side Return Air from Both Sides or Return Air from Bottom and One Side.										Single Side Return Air - Air volumes in <b>bold</b> (over 1800 cfm) require Optional Return Air Base and field fabricated transition to accommodate 20 x 25 x 1 in. air filter in order to maintain proper air velocity.									
	High (Black)		Medium-High (Brown)		Medium (Blue)		Medium-Low (Yellow)		Low (Red)		High (Black)		Medium-High (Brown)		Medium (Blue)		Medium-Low (Yellow)		Low (Red)	
	cfm	Watts	cfm	Watts	cfm	Watts	cfm	Watts	cfm	Watts	cfm	Watts	cfm	Watts	cfm	Watts	cfm	Watts	cfm	Watts
0.00	2175	590	2050	410	1850	310	1695	275	1510	195	<b>2175</b>	<b>605</b>	<b>1930</b>	<b>420</b>	1785	320	1675	260	1500	195
0.10	2158	607	1943	421	1778	328	1650	283	1461	205	<b>2129</b>	<b>628</b>	<b>1892</b>	<b>441</b>	1733	345	1627	288	1458	209
0.20	2131	620	1897	436	1719	345	1591	299	1405	215	<b>2091</b>	<b>649</b>	<b>1838</b>	<b>458</b>	1691	360	1586	297	1407	220
0.30	2085	639	1847	456	1678	354	1563	308	1351	228	<b>2072</b>	<b>660</b>	<b>1806</b>	<b>471</b>	1631	371	1529	313	1353	232
0.40	2055	652	1806	466	1641	371	1499	317	1297	238	<b>2014</b>	<b>677</b>	1772	485	1591	385	1485	327	1302	243
0.50	2030	668	1767	476	1588	387	1462	333	1256	254	<b>1977</b>	<b>690</b>	1742	498	1554	395	1444	337	1252	256
0.60	1976	686	1724	495	1550	399	1419	348	1215	265	<b>1960</b>	<b>707</b>	1696	511	1511	410	1412	348	1204	265
0.70	1949	700	1685	510	1512	408	1371	357	1168	271	<b>1913</b>	<b>720</b>	1661	525	1480	424	1351	359	1149	274
0.80	1896	716	1649	527	1473	419	1332	372	1121	287	<b>1873</b>	<b>738</b>	1617	538	1440	437	1313	371	1117	285









## REVISIONS

Sections	Description of Change
Optional Accessories	E30 catalog number updated.



Visit us at [www.Lennox.com](http://www.Lennox.com)

For the latest technical information, [www.LennoxPros.com](http://www.LennoxPros.com)

Contact us at 1-800-4-LENNOX

NOTE - Due to Lennox' ongoing commitment to quality, Specifications, Ratings and Dimensions subject to change without notice and without incurring liability. Improper installation, adjustment, alteration, service or maintenance can cause property damage or personal injury. Installation and service must be performed by a qualified installer and servicing agency.

©2020 Lennox Industries, Inc.