



**RESIDENTIAL  
PRODUCT SPECIFICATIONS**

Bulletin No. 210648  
June 2020  
Supersedes March 2019



**ELITE®  
SERIES**



**AFUE - Up to 96%**  
**Input - 44,000 to 110,000 Btuh**  
**Nominal Add-on Cooling - 1.5 to 5 Tons**

**MODEL NUMBER IDENTIFICATION**

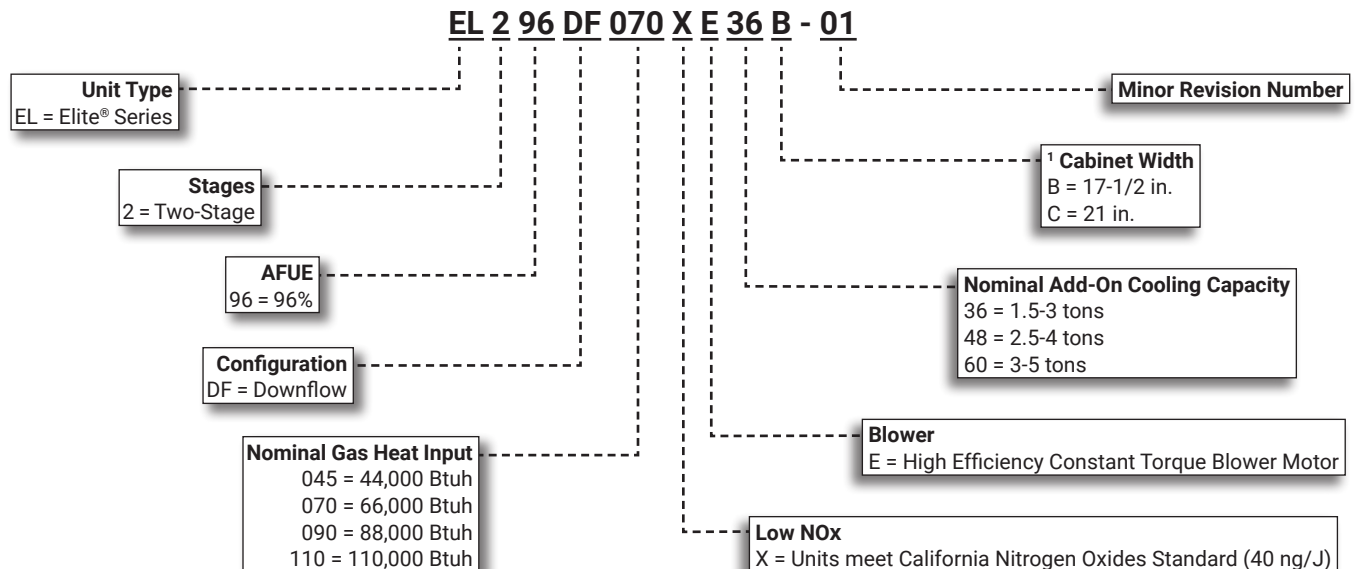

<sup>1</sup> Downflow indoor coils with the same letter designation will physically match the furnace supply air opening.

## FEATURE HIGHLIGHTS

1. Lennox Duralok Plus™ Heat Exchanger
2. Secondary Heat Exchanger
3. Inshot Burners
4. Two-Stage Gas Control Valve
5. Two-Speed Combustion Air Inducer
6. SureLight® Integrated Furnace Control
7. Variable Speed Direct Drive Blower
8. Insulated Cabinet
9. Safety Interlock Switch
10. Gas Piping And Electrical Inlets

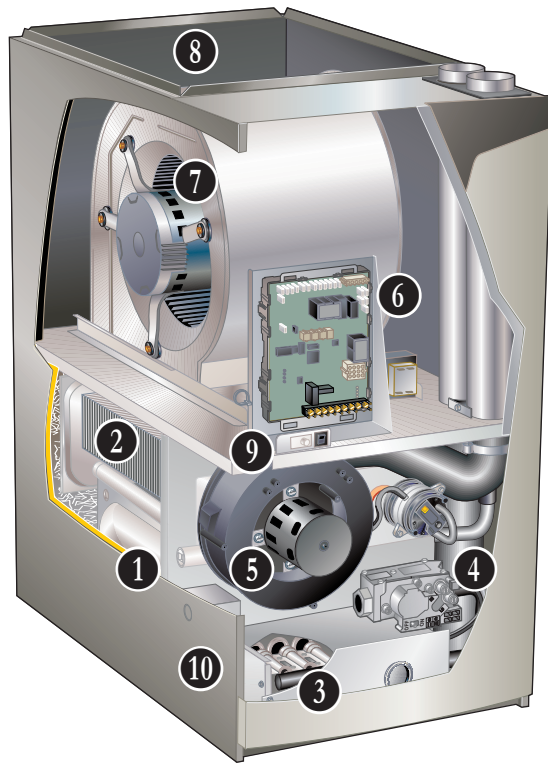

## CONTENTS

Approvals And Warranty . . . . .	3
Blower Data . . . . .	19
Dimensions - Optional Accessories . . . . .	14
Dimensions - Optional Accessories - Venting . . . . .	16
Dimensions - Unit . . . . .	13
Features . . . . .	3
Gas Heat Accessories . . . . .	12
High Altitude Derate . . . . .	12
Installation Clearances . . . . .	8
Optional Accessories - Order Separately . . . . .	9
Specifications . . . . .	8
Vent Lengths . . . . .	11
Vent Lengths - Uninsulated Exhaust Pipe In Unconditioned Space . . . . .	10

## APPROVALS AND WARRANTY

### APPROVALS

- AHRI Certified
- CSA International Certified
- Tested and rated according to US DOE test procedures and FTC labeling regulations
- Units are approved for installations from 0 - 4500 ft.
- ENERGY STAR® certified units are designed to use less energy, help save money on utility bills, and help protect the environment
- ISO 9001 Registered Manufacturing Quality System
- Blower data from unit tests conducted in Lennox Laboratory air test chamber

### California Only

- These furnaces **do not meet** the South Coast Air Quality Management District (SCAQMD) Rule 1111 and San Joaquin Valley Air Pollution Control District (SJVAPCD) Rule 4905 NOx emission limit (14 ng/J) and cannot be installed within the SCAQMD and SJVAPCD areas
- These furnaces are approved by the California Energy Commission and meets California Nitrogen Oxides Standard (NOx) limits of 40 ng/J

### WARRANTY

- Duralok Plus™ Aluminized Steel Heat Exchanger:
  - Limited lifetime (twenty year transferable) in residential applications
  - Limited ten years in non-residential applications
- All other covered components:
  - Limited five years in residential installations
  - Limited one year in non-residential installations

**NOTE** - Refer to Lennox Equipment Limited Warranty certificate included with unit for specific details.

## FEATURES

### APPLICATIONS

- Input capacities of 44,000, 66,000, 88,000 and 110,000 Btuh
- Energy efficiency (AFUE) - up to 96%
- Compact cabinet for downflow applications without any internal modifications to the unit
- Lennox add-on indoor coils, high-efficiency air cleaners and humidifiers can easily be added to furnace
- Shipped factory assembled with controls installed and wired
- Each unit factory test operated to ensure proper operation

### HEATING SYSTEM

- 1 **Lennox Duralok Plus™ Heat Exchanger Assembly**
  - Lennox developed heat exchanger assembly consists of primary heat exchanger and secondary condenser coil assembly
  - Main multi-pass crimped seam design clamshell type
  - Constructed of heavy-gauge, aluminized steel

- Designed for normal expansion and contraction with maximum efficiency and minimum resistance to air flow
- 2 • Secondary heat exchanger condenser coil constructed of aluminum fins fitted to stainless steel tubes
- Coil is factory tested for leaks
- Condensate drain header box assembly located on front of coil
- Compact size permits low overall design of furnace cabinet
- Laboratory life cycle tested in excess of industry standards

### **Lennox Designed Header Box**

- Header box on end of condenser coil collects flue condensate for disposal through condensate drains
- Drains are located on each side of the cabinet for easy field installation of condensate drain trap
- Only one drain is used, the other drain is sealed
- Condensate drain trap is included with the unit for field installation

## FEATURES

### HEATING SYSTEM (continued)

#### Lennox Designed Flue Condensate Trap Assembly

- Field installed outside the conditioned air stream
- Assembly can be mounted on either side of cabinet
- See Installation Instructions
- 90° street elbow furnished for ease of drain trap installation
- Drain connection can be made with field provided PVC pipe, PVC coupling, or vinyl tubing with hose clamp
- Drain cap on trap allows easy cleaning and winterizing

### 3 Inshot Burners

- Aluminized steel inshot burners provide efficient, trouble-free operation
- Burner venturi mixes air and gas in correct proportion for proper combustion
- Burner assembly can be removed from the unit as a single component for ease of service

#### SureLight® Hot Surface Ignitor

- Tough, reliable, long-life, trouble-free performance.
- Silicon nitride ignitor.
- Cemented to steatite block for protection against current leakage.
- Ignition leads are constructed of nickel plated copper and are enclosed in high temperature Teflon® insulation for dependable operation.

### 4 Two-Stage Gas Control Valve

- 24 volt redundant combination two-stage gas control valve combines manual shut off switch (On-Off), automatic electric valve (dual) and gas pressure regulation into a compact combination control.

### 5 Two-Speed Combustion Air Inducer

- Permanent split capacitor (PSC), heavy duty blower prepurges heat exchanger and safely vents flue products
- Operates only during heating cycle
- Dual pressure switches (low fire/high fire) prove blower operation before allowing gas valve to open

#### Flame Rollout Switches (2)

- Factory installed on burner box
- Switch provides protection from abnormal operating conditions
- Manual reset

#### Limit Control

- Primary limit is accurately located on vestibule panel
- Automatic reset

### Optional Accessories

#### High Altitude Orifice Kits

- Required on all units for proper unit operation at altitudes from 7501 to 10,000 ft.
- Available for natural gas and LPG/propane

#### High Altitude Pressure Switch Kit

- Required for proper unit operation on installations above 4500 ft.

#### Natural Gas to LPG/Propane Conversion Kit

- Required for field changeover from natural gas to LPG/Propane

#### LPG/Propane to Natural Gas Conversion Kit

- Required for field changeover from LPG/Propane to natural gas

### DIRECT VENT / NON-DIRECT VENT SEALED COMBUSTION SYSTEM

- Furnace features a “sealed combustion” system and can be installed in either Direct Vent or Non-Direct applications.
- In Direct Vent applications, combustion air is supplied from outdoors and flue gases are discharged outdoors.
- In Non-Direct Vent applications, combustion air is supplied from indoors and flue gases are discharged outdoors.

**NOTE** - Lennox has approved the use of DuraVent® PolyPro® and Centrotherm InnoFlue® manufactured vent pipe and terminations as an alternative to PVC vent pipe. Must be ordered separately. Tested and listed to the ULC S636 standard in Canada. The polypropylene venting system must follow the uninsulated and unconditioned space vent lengths listed in the table on 10.

Refer to the Installation Instructions for additional details.

### DIRECT VENT / NON-DIRECT VENT SEALED COMBUSTION SYSTEM

- Furnace features a “sealed combustion” system and can be installed in either Direct Vent or Non-Direct applications
- In Direct Vent applications, combustion air is supplied from outdoors and flue gases are discharged outdoors
- In Non-Direct Vent applications, combustion air is supplied from indoors and flue gases are discharged outdoors

**NOTE** - Lennox has approved the use of DuraVent® PolyPro® and Centrotherm InnoFlue® manufactured vent pipe and terminations as an alternative to PVC vent pipe. Must be ordered separately.

- Tested and listed to the ULC S636 standard in Canada

## FEATURES

### **DIRECT VENT / NON-DIRECT VENT SEALED COMBUSTION SYSTEM (continued)**

- The polypropylene venting system must follow the uninsulated and unconditioned space vent lengths listed in the table on 10
- Refer to the Installation Instructions for additional details

#### **Flue Coupling**

- Assists with exhaust flue piping connection and servicing
- Includes flexible one 2 inch rubber coupling and two adjustable bands
- Approved for all Lennox 90% furnaces

#### **Termination Kits**

- Facilitates installation of combustion air intake pipe and flue exhaust pipe
- Refer to venting table in this bulletin to determine pipe size needed and proper termination kit required
- Certain Termination Kits are certified to ULC S636 standard for use in Canada only
- See Optional Accessories table and dimension drawings

#### **Concentric - Direct Vent Applications**

- 2 or 3 inch kit contains concentric termination assembly, reducer bushing and 45 degree elbow
- 2 inch kit for -045-070 models contains an outdoor exhaust accelerator
- Kit requires single hole penetration of roof or wall for installation
- Roof Termination Flashing Kit is available for use with 2 inch Kits
- CSA certified

#### **Flush-Mount**

- Kit contains flush-mount termination, accelerator, mounting template and hardware
- Kit may be used with 2, 2-1/2 or 3 in. pipe

#### **Wall Assembly**

##### **Close Couple (US Only) - Direct Vent Applications**

- 2 or 3 inch kit consists of close-couple, side-by-side PVC piping with galvanized steel wall cover plate for sealing and isolating piping penetration of the wall
- Piping spacing and length is sized for proper wall installations
- CSA certified

##### **Close Couple WTK (Canada Only) - Direct Vent Applications**

- 2 or 3 inch kit contains one insulated faceplate, one insulated exhaust pipe, elbow and fittings. Certified to ULC S636 standard

##### **Wall Ring - Direct Vent or Non-Direct Vent Applications**

- 2 inch kit contains 2 stainless steel outside seal caps, 2 galvanized steel inside seal caps, 4 seal rings for the caps and 18 inch insulation sleeve for sealing and isolating intake and exhaust piping penetration of wall

**NOTE** - Maintain a maximum of 6 inches between the inlet and outlet openings in the installation of the pipes.

#### **Roof Termination Flashing Kit**

- For vertical venting through a roof
- 3 inch kit contains two neoprene rubber roof flashings
- Vent pipe and insulation not furnished
- Flashing Kit can also be used with 2 inch Concentric Vent Termination Kits used in vertical venting rooftop applications

## **CONTROLS**

### **6 SureLight® Integrated Furnace Control**

- Contains all necessary controls and relays to operate furnace
- Combustion air inducer is operated by the integrated furnace control
- Prior to ignition, a pre-purge cycle for 15 seconds is initiated
- After the main burners are turned off, a post-purge cycle for 5 seconds is run
- **Safety Controls** - Flame sensor utilizes flame rectification for safe and reliable operation
- Should loss of flame occur, the integrated furnace control will initiate 4 re-attempts at ignition before locking out unit operation for 60 minutes
- Watchguard type circuit automatically resets ignition controls after one hour of continuous thermostat demand after unit lockout, eliminating nuisance calls for service
- **Thermostat Control** - For optimal performance, the use of a high-quality, digital two-stage thermostat with adjustable settings for first stage/second stage, on/off differentials and adjustable stage timers is recommended

#### **Furnace Input Staging Options**

<b>Thermostat Type</b>	<b>Input Staging Available</b>
<b>Two-Stage (Conventional)</b>	Determined by thermostat demand
<b>Single-Stage (Conventional)</b>	2nd-stage heat ON delay (DIP switch setting) OFF - 7 minutes (factory) ON - 12 minutes

- **Display LED** - Seven segment LED displays alpha-numeric information related to diagnostics as well as system operation and status
- Diagnostic codes are held in non-volatile memory, immune from power interruptions
- Holds up to ten diagnostic codes in order of occurrence for recall on demand
- Port on blower door allows for easy viewing

#### **DIP Switch Settings**

- **Select Thermostat Used** - Single-Stage or Two-Stage
- Two selectable second stage recognition times (7 and 12 minutes) are available on the control when the furnace is used with a single-stage thermostat

## FEATURES

### CONTROLS (continued)

- When used with a two-stage thermostat, furnace will only initiate second stage operation with a second stage thermostat demand
- **Second Stage Delay** - Used with single-stage thermostat only. See Furnace Input Staging Options table for details
- **Blower On/Off Time (Heating)** - Blower on time is fixed at 30 seconds, blower off time is adjustable from 60, 90, 120 and 180 seconds (factory setting - 90 seconds)
- **Blower On/Off Time (Cooling)** - For air-conditioning applications, blower "on" time is 2 seconds following thermostat demand for cooling
- Blower "off" time in cooling mode is adjustable from 2 or 45 seconds (factory setting - 45 seconds)
- For air-conditioning applications, blower is automatically energized on thermostat demand for cooling
- **Heating Speeds** - Low Heat or High Heat
- **Cooling Speeds** - Low Cool or High Cool
- **Continuous Speed** - Low Heat (factory setting) - adjustable
- **Dehumidification** - A jumper on the control must be clipped to enable dehumidification
- A humidity controlling thermostat or device is also required
- During a call for cooling, air volume is automatically reduced, forcing humidity removal by the air conditioner or heat pump system (single stage units or two-stage units running at 2nd stage)
- After the humidity has reached the desired set-point the cooling air volume returns to its designed rate
- **Dual-Fuel Operation** - A jumper on the control must be clipped to enable operation with a single or two-stage heat pump
- The indoor blower is started without delay when a call for heat is received
- **Two-Stage Compressor Operation** - A jumper on the control must be clipped to enable operation with a two-stage compressor
- **Accessory Terminal** - One accessory terminal furnished for additional power supply requirements for 120 volt (less than 1 amp) powered air cleaners
- One unpowered pair of contacts are provided for humidifier connections and may be connected to 24V or 120V
- Control is factory installed in the unit control box

### 24 Volt Transformer

- Furnished and factory installed in control box
- 40VA transformer has circuit breaker wired in series

### Field Wiring Make-up Box

- Furnished for line voltage wiring
- Factory installed internally on left side of furnace
- Box may be installed internally or externally on either side of furnace

### Optional Accessories

#### iComfort® E30 Smart Wi-Fi Thermostat

- Wi-Fi enabled, electronic 7-day, universal, multi-stage, programmable, touchscreen thermostat
- 3 Heat/2 Cool
- Auto-changeover
- Controls dehumidification during cooling mode and humidification during heating mode
- Offers enhanced capabilities including humidification / dehumidification / dewpoint measurement and control, Humiditrol® control, and equipment maintenance reminders
- Easy to read 7 in. color touchscreen (measured diagonally)
- LCD display with backlight shows the current and set temperature, time, inside relative humidity, system status (operating mode and schedules) and outside temperature (optional outdoor sensor required)
- Smooth Setback Recovery starts system early to achieve setpoint at start of program period
- Compressor short-cycle protection (5 minutes)
- Up to four separate schedules are available plus Schedule IQ™
- One-Touch Away Mode - A quick and easy way to set the cooling and heating setpoints while away
- Smart Away™ - Uses geo-fencing technology to determine when the homeowner is within a predetermined distance from the home to operate the system when leaving, away and arriving
- Wi-Fi remote monitoring and adjustment through a home wireless network for desktop PCs, laptops and apps for smartphones or tablets
- Smart home automation compatible with Apple HomeKit™, Amazon Alexa®, Google Assistant and IFTTT
- Service Dashboard features online real-time monitoring of installed iComfort® Communicating systems
- High Definition Color Display and Subbase, Smart Hub Controller, wallplate (for retrofit installations) furnished for easy installation
- See the iComfort® E30 Smart Wi-Fi Thermostat Product Specifications bulletin for more information



#### Remote Outdoor Temperature Sensor

- iComfort® E30 Smart Thermostat
- When installed outdoors, sensor allows thermostat to display outdoor temperature

**NOTE** - Sensor is required for Enhanced Dehumidification Control (EDA) applications.

**NOTE** - The outdoor sensor is furnished as standard with iComfort® Communicating outdoor units, optional for conventional units.



#### Thermostat

- Thermostat is not furnished with unit
- See Lennox Price Book for selection

## FEATURES

### **CONTROLS (continued)**

#### **Furnace Twinning Kit**

- Required to operate two furnaces simultaneously.
- Kit consists of twinning relays, quick connect terminals and mounting hardware
- Used for two-stage heating/single-stage cooling with either a single-stage or two-stage thermostat

#### **Night Service Kit**

- Contains most commonly used service parts
- Furnace control
- Gas valve
- Ignitor
- Transformer
- Flame sensor
- Service manual

#### **Blower Relay Kit**

- For use with two-stage outdoor units
- Allows furnace blower speed changes when matched with two-stage air conditioners or heat pumps

### **BLOWER**

- Direct drive blower
- Statically and dynamically balanced
- Resiliently mounted
- Blower assembly easily removed for servicing

#### **7 Power Saver™ Constant Torque Blower Motor**

- DC Brushless Motor
- High Efficiency Constant Torque
- ECM (Electronically Commutated Motor)
- Motor is programmed to provide constant torque at each of the selectable speeds
- Motor is controlled by the SureLight® Integrated Furnace Control
- Blower speeds are easily changed on the integrated furnace control. See Blower Data tables

### **CABINET**

- Low-profile, narrow width allows easy installation
- Heavy-gauge, cold rolled steel construction
- Pre-painted cabinet finish
- Flanges provided on supply air opening for ease of plenum connection or alignment with indoor coil
- 8** • Insulated with foil faced insulation on sides and back of heating compartment and mat faced insulation in blower compartment.
- Sealed blower compartment
- Inner blower compartment access panel seals blower compartment from air leakage
- Cabinet door can be removed without any tools
- Complete service access
- 9** • Safety interlock switch automatically shuts off power to unit when blower compartment access door is removed

- 10** • Gas piping and electrical inlets are provided in both sides of cabinet

#### **Coil Match-Up**

- All Lennox downflow indoor coils will physically match the furnace **supply air opening** with the same letter designation (A, B, C, D) as in the furnace model number

#### **Low Leakage Cabinet**

- All models have less than 2% air leakage and meet ANSI/ASHRAE Standard 193-2010 "Method of Test for Determining the Air Tightness of HVAC Equipment"

### **Optional Accessories**

#### **Condensate Drain Heat Cable Kits**

- Self-limiting wattage heat cable prevents condensate drain from freezing in unconditioned areas
- Available in 6 or 24 ft. lengths

#### **Crawl Space Vent Drain Kit**

- Allows venting through a crawl space for downflow applications
- Includes 2 or 3 in. sanitary tee, 2 in. PVC assembly, PCV boot and clamp
- Kit for Canada is certified to ULC S636

#### **Downflow Combustible Flooring Base**

- Required for heating only units installed on combustible floors
- Not required in add-on cooling applications
- See Dimension Drawing

#### **High Performance Economizer (Commercial Applications Only)**

- Designed for applications requiring outdoor air to be utilized in a commercial HVAC system
- Allows the entry of fresh outdoor air for free cooling, reducing the requirement for mechanical cooling
- Heavy gauge galvanized steel cabinet lined with thick fiberglass insulation
- Mixed air sensor, outdoor air sensor and 24VAC transformer furnished
- Approved for California Title 24 building standards. ASHRAE 90.1-2010 compliant
- See separate Product Specifications bulletin for additional information and available control and sensor options

#### **FILTER (not furnished)**

- Filter and provisions for external mounting must be field provided

### **Optional Accessories**

#### **Downflow Filter Cabinet**

- Filter cabinet mounts directly on top of furnace
- "B" and "C" width cabinets have two filters
- Filter rails are furnished
- Front access for servicing
- Cleanable filter(s) are furnished

## SPECIFICATIONS

Gas Heating Performance		Model No.	EL296DF045XE36B	EL296DF070XE48B	EL296DF090XE48C	EL296DF110XE60C
AHRI Ref. No.			5625722	5625723	5940633	5625725
<sup>1</sup> AFUE			96%	96%	96%	96%
High Fire	Input - Btuh		44,000	66,000	88,000	110,000
	Output - Btuh		43,000	64,000	85,000	106,000
	Temperature rise range - °F		35-65	35-65	40-70	45-75
Gas Manifold Pressure (in. w.g.) Nat. Gas / LPG/Propane			3.5 / 10.0	3.5 / 10.0	3.5 / 10.0	3.5 / 10.0
Low Fire	Input - Btuh		29,000	43,000	57,000	72,000
	Output - Btuh		28,000	42,000	55,000	70,000
	Temperature rise range - °F		20 - 50	25 - 55	30 - 60	35 - 65
Gas Manifold Pressure (in. w.g.) Nat. Gas / LPG/Propane			1.7 / 4.5	1.7 / 4.5	1.7 / 4.5	1.7 / 4.5
High static - in. w.g.			0.5	0.5	0.5	0.5
Connections in.	Intake / Exhaust Pipe (PVC)		2 / 2	2 / 2	2 / 2	2 / 2
	Gas pipe size IPS		1/2	1/2	1/2	1/2
	Condensate Drain Trap (PVC pipe) - i.d.		3/4	3/4	3/4	3/4
	with furnished 90° street elbow with field supplied (PVC coupling) - o.d.		3/4 slip x 3/4 Mipt 3/4 slip x 3/4 MPT	3/4 slip x 3/4 Mipt 3/4 slip x 3/4 MPT	3/4 slip x 3/4 Mipt 3/4 slip x 3/4 MPT	3/4 slip x 3/4 Mipt 3/4 slip x 3/4 MPT
Indoor Blower	Wheel nom. diameter x width - in.		10 x 8	11-1/2 x 10	10 x 10	11 x 11
	Motor Type		DC Brushless	DC Brushless	DC Brushless	DC Brushless
	Motor output - hp		1/2	3/4	3/4	1
	Tons of add-on cooling		1.5 - 3	2 - 4	2 - 4	3 - 5
	Air Volume Range - cfm		485 - 1395	520 - 1770	760 - 1765	1045 - 2285
Electrical Data	Voltage		120 volts - 60 hertz - 1 phase			
	Blower motor full load amps		6.8	8.4	8.4	10.9
	Maximum overcurrent protection		15	15	15	15
Shipping Data	lbs. - 1 package		134	145	163	175

NOTE - Filters and provisions for mounting are not furnished and must be field provided.

<sup>1</sup> Annual Fuel Utilization Efficiency based on DOE test procedures and according to FTC labeling regulations. Isolated combustion system rating for non-weatherized furnaces.

## INSTALLATION CLEARANCES

Sides	<sup>1</sup> 0 inches (0 mm)
Rear	0 inches (0 mm)
Top/Plenum	1 inch (25 mm)
Front	0 inches (0 mm)
Front (service/alcove)	24 inches (610 mm)
Floor	<sup>2</sup> Combustible

NOTE - Air for combustion must conform to the methods outlined in the National Fuel Gas Code (NFPA 54/ANSI-Z223.1) or the National Standard of Canada CAN/CSA-B149.1 "Natural Gas and Propane Installation Code".

NOTE - In the U.S. flue sizing must conform to the methods outlined in the current National Fuel Gas Code (NFPA 54/ANSI-Z223.1) or applicable provisions of local building codes. In Canada flue sizing must conform to the methods outlined in National Standard of Canada CAN/CSA-B149.1.

<sup>1</sup> Allow proper clearances to accommodate condensate trap and vent pipe installation.

<sup>2</sup> Clearance for installation on combustible floor if Optional Downflow Combustible Flooring Base is installed between furnace and combustible floor. Not required in add-on cooling applications if installed in accordance with local codes or National Fuel Gas Code ANSI-Z223.1 or CAN/CSA-149.1.,2. Do not install the furnace directly on carpeting, tile, or other combustible materials other than wood flooring.



## OPTIONAL ACCESSORIES - ORDER SEPARATELY

		"B" Width Models	"C" Width Models	
<b>CABINET ACCESSORIES</b>				
Downflow Combustible Flooring Base		11M60	11M61	
High Performance Economizer (Commercial Only)		10U53	10U53	
<b>CONTROLS</b>				
Blower Relay Kit (for two-stage outdoor units)		85W66	85W66	
Furnace Twinning Kit		16W72	16W72	
iComfort® E30 Smart Thermostat		15S63	15S63	
Remote Outdoor Temperature Sensor		X2658	X2658	
Night Service Kit		10B39	10B39	
<b>CONDENSATE DRAIN KITS</b>				
Condensate Drain Heat Cable	6 ft.	26K68	26K68	
	24 ft.	26K69	26K69	
Crawl Space Vent Drain Kit	US	51W18	51W18	
	Canada	15Z70	15Z70	
<b>FILTERS</b>				
<sup>1</sup> Downflow Filter Cabinet		51W07	51W08	
	No. and Size of filter - in.	(2) 16 x 20 x 1	(2) 16 x 20 x 1	
<b>TERMINATION KITS</b>				
See Installation Instructions for specific venting information.				
Termination Kits - Direct Vent Applications Only	Concentric	US - 2 in.	71M80	69M29
		3 in.	---	60L46
		Canada - 2 in.	44W92	44W92
		3 in.	---	44W93
	Flush-Mount	US - 2, 2-1/2 or 3 in.	51W11	51W11
		Canada - 2, 2-1/2 or 3 in.	51W12	51W12
	Wall - Close Couple	US - 2 in.	22G44	---
		3 in.	44J40	44J40
	Wall - Close Couple WTK	Canada - 2 in.	30G28	---
		3 in.	81J20	81J20
Termination Kits - Direct or Non-Direct Vent	Roof	2 in.	15F75	15F75
	Wall Ring Kit	2 in.	15F74	<sup>3</sup> 15F74
<sup>2</sup> Roof Termination Flashing Kit - Direct or Non-Direct Vent (2 flashings)		3 in.	44J41	44J41
<b>VENTING</b>				
Flue Coupling		2 in.	17H92	17H92
<sup>4</sup> Left Side Vent Kit		2 or 3 in.	87W73	87W73

<sup>1</sup> Cleanable polyurethane, frame-type filter.

<sup>2</sup> Kits contain enough parts for two, non-direct vent installations.

<sup>3</sup> Non-direct vent only.

<sup>4</sup> NOTE - The curved exhaust pipe furnished with the Left Side Vent Kit counts as one additional 2 in. diameter 90° elbow. When using 3 in. diameter pipe, the furnished curved exhaust pipe and field provided fittings to transition from 2 in. to 3 in. count as 20 feet of equivalent pipe on all units.

NOTE - Termination Kits (44W92, 44W93, 30G28, 51W12, 51W19, 81J20) and Crawl Space Vent Drain Kit (15Z70) are certified to ULC S636 standard for use in Canada only.

## OUTDOOR TERMINATION KIT USAGE

Input Size	Vent Pipe Diameter (in.)	Standard Terminations					Concentric Terminations			
		Flush Mount Kit	Wall Kit		Wall Ring Kit	Field Fabricated Exhaust Accelerator Size Required	Concentric Kit			
			2 inch	3 inch	2 inch		1-1/2 inch	2 inch	3 inch	
			51W11 (US) 4 51W12 (CA)	22G44 (US) 4 30G28 (CA)	44J40 (US) 4 81J20 (CA)		15F74	71M80 (US) 4 44W92 (CA)	69M29 (US) 4 44W92 (CA)	60L46 (US) 4 44W93 (CA)
045	2	<sup>3</sup> YES	YES	<sup>1</sup> YES	YES	1-1/2 in.	<sup>2</sup> YES	---	---	
	2-1/2	<sup>3</sup> YES	YES	<sup>1</sup> YES	YES	1-1/2 in.	<sup>2</sup> YES	---	---	
	3	<sup>3</sup> YES	YES	<sup>1</sup> YES	YES	1-1/2 in.	<sup>2</sup> YES	---	---	
070	2	<sup>3</sup> YES	YES	<sup>1</sup> YES	YES	1-1/2 in.	<sup>2</sup> YES	---	---	
	2-1/2	<sup>3</sup> YES	YES	<sup>1</sup> YES	YES	1-1/2 in.	<sup>2</sup> YES	---	---	
	3	<sup>3</sup> YES	YES	<sup>1</sup> YES	YES	1-1/2 in.	<sup>2</sup> YES	---	---	
090	2	<sup>3</sup> YES	---	YES	<sup>1</sup> YES	2 in.	---	YES	YES	
	2-1/2	<sup>3</sup> YES	---	YES	<sup>1</sup> YES	2 in.	---	YES	YES	
	3	<sup>3</sup> YES	---	YES	<sup>1</sup> YES	2 in.	---	YES	YES	
110	2	YES	---	YES	YES	2 in.	---	YES	YES	
	2-1/2	YES	---	YES	---	2 in.	---	YES	YES	
	3	YES	---	YES	---	2 in.	---	YES	YES	

NOTE - Standard Terminations do not include any vent pipe or elbows external to the structure.

Any vent pipe or elbows external to the structure must be included in total vent length calculations. See Vent Length Tables.

<sup>1</sup> Requires field provided 1-1/2 in. outdoor exhaust accelerator.

<sup>2</sup> Concentric Kits **71M80** and **44W92** include 1-1/2 in. outdoor exhaust accelerator, required when used with 045 and 070 input models. Accelerator is not used with 090, 110, 135 input models.

<sup>3</sup> Flush Mount Kit **51W11** and **51W12** includes 1-1/2 in. outdoor exhaust accelerator, required when used with 045, 070 and 090 input models. Accelerator is not used with 110 or 135 input models.

<sup>4</sup> Termination Kits **30G28**, **44W92**, **44W93**, **51W12** and **81J20** are certified to ULC S636 standard for use in Canada only.

## VENT LENGTHS - UNINSULATED EXHAUST PIPE IN UNCONDITIONED SPACE

1 Winter Design Temperatures	Vent Pipe Diameter	Unit Input Size							
		045		070		090		110	
		Maximum Un-Insulated Exhaust Vent Length (ft.)							
		PVC	PolyPro InnoFlue	PVC	PolyPro InnoFlue	PVC	PolyPro InnoFlue	PVC	PolyPro InnoFlue
32 to 21°F	2 in.	21	18	33	30	46	42	30	30
	2-1/2 in.	16	N/A	26	N/A	37	N/A	36	N/A
	3 in.	12	12	21	21	30	30	29	29
20 to 1°F	2 in.	11	9	19	17	28	25	27	24
	2-1/2 in.	7	N/A	14	N/A	21	N/A	20	N/A
	3 in.	N/A	N/A	9	9	16	16	14	14
0 to -20°F	2 in.	6	4	12	10	19	16	18	15
	2-1/2 in.	N/A	N/A	7	N/A	13	N/A	12	N/A
	3 in.	N/A	N/A	N/A	N/A	8	8	7	7

NOTE - Concentric terminations are equivalent to 5 ft. of straight pipe and should be included when measuring total pipe length.

<sup>1</sup> Refer to 99% Minimum Design Temperature table provided in the current edition of ASHRAE Handbook-Fundamentals.

PolyPro® poly-propylene vent pipe is a registered trademark of DuraVent®.

InnoFlue® is a registered trademark of Centrotherm Eco Systems.

## VENT LENGTHS

### STANDARD TERMINATION AT ELEVATION 0 - 4500 ft.

Pipe Size	Input	2 in.				2-1/2 in.				3 in.			
		045	070	090	110	045	070	090	110	045	070	090	110
No. of 90 ELL	1	71	56	34	14	105	105	83	48	128	127	108	108
	2	66	51	29	9	100	100	78	43	123	122	103	103
	3	61	46	24	4	95	95	73	38	118	117	98	98
	4	56	41	19	N/A	90	90	68	33	113	112	93	93
	5	51	36	14	N/A	85	85	63	28	108	107	88	88
	6	46	31	9	N/A	80	80	58	23	101	102	83	83
	7	41	26	4	N/A	75	75	53	18	98	97	78	78
	8	36	21	N/A	N/A	70	70	48	13	93	92	73	73
	9	31	16	N/A	N/A	65	65	43	8	88	87	68	68
	10	26	11	N/A	N/A	60	60	38	3	83	82	63	63

### STANDARD TERMINATION ELEVATION 4501 - 10,000 ft.

Pipe Size	Input	2 in.				2-1/2 in.				3 in.			
		045	070	090	110	045	070	090	110	045	070	090	110
No. of 90 ELL	1	71	56	34	N/A	105	105	83	48	128	127	108	108
	2	66	51	29	N/A	100	100	78	43	123	122	103	103
	3	61	46	24	N/A	95	95	73	38	118	117	98	98
	4	56	41	19	N/A	90	90	68	33	113	112	93	93
	5	51	36	14	N/A	85	85	63	28	108	107	88	88
	6	46	31	9	N/A	80	80	58	23	103	102	83	83
	7	41	26	4	N/A	75	75	53	18	98	97	78	78
	8	36	21	N/A	N/A	70	70	48	13	93	92	73	73
	9	31	16	N/A	N/A	65	65	43	8	88	87	68	68
	10	26	11	N/A	N/A	60	60	38	3	83	82	63	63

### CONCENTRIC TERMINATION AT ELEVATION 0 - 4500 ft.

Pipe Size	Input	2 in.				2-1/2 in.				3 in.			
		045	070	090	110	045	070	090	110	045	070	090	110
No. of 90 ELL	1	63	48	32	12	95	95	79	44	111	111	104	104
	2	58	43	27	7	90	90	74	39	106	106	99	99
	3	53	38	22	2	85	85	69	34	101	91	94	94
	4	48	33	17	N/A	80	80	64	29	96	96	89	89
	5	43	28	12	N/A	75	75	59	24	91	91	84	84
	6	38	23	7	N/A	70	70	54	19	96	86	79	79
	7	33	18	2	N/A	65	65	49	14	81	81	74	74
	8	28	13	N/A	N/A	60	60	44	9	76	76	69	69
	9	23	8	N/A	N/A	55	55	39	4	71	71	64	64
	10	18	3	N/A	N/A	50	50	34	N/A	66	66	59	59

### CONCENTRIC TERMINATION ELEVATION 4501 - 10,000 ft.

Pipe Size	Input	2 in.				2-1/2 in.				3 in.			
		045	070	090	110	045	070	090	110	045	070	090	110
No. of 90 ELL	1	63	48	32	N/A	95	95	79	44	111	111	104	94
	2	58	43	27	N/A	90	90	74	39	106	106	99	99
	3	53	38	22	N/A	85	85	69	34	101	101	94	94
	4	48	33	17	N/A	80	80	64	29	96	96	89	89
	5	43	28	12	N/A	75	75	59	24	91	91	84	84
	6	38	23	7	N/A	70	70	54	19	86	86	79	79
	7	33	18	2	N/A	65	65	49	14	81	81	74	74
	8	28	13	N/A	N/A	60	60	44	9	76	76	69	69
	9	23	8	N/A	N/A	55	55	39	4	71	71	64	64
	10	18	3	N/A	N/A	50	50	34	N/A	66	66	59	59

## VENT LENGTHS (EXHAUST) - VENTILATED ATTIC OR CRAWLSPACE INTAKE AIR

STANDARD TERMINATION AT ELEVATION 0 - 10,000 ft.

	Pipe Size	2 in.				2-1/2 in.				3 in.			
	Input	045	070	090	110	045	070	090	110	045	070	090	110
<b>No. of 90 ELL</b>	1	61	46	24	4	90	90	68	33	108	107	88	88
	2	56	41	19	N/A	85	85	63	28	103	102	83	83
	3	51	36	14	N/A	80	80	58	23	98	97	78	78
	4	46	31	9	N/A	85	75	63	18	93	92	73	73
	5	41	26	4	N/A	70	70	48	13	88	87	68	68
	6	36	21	N/A	N/A	65	65	43	8	83	82	63	63
	7	31	16	N/A	N/A	60	60	38	3	78	77	58	58
	8	26	11	N/A	N/A	55	55	33	N/A	73	72	53	53
	9	21	6	N/A	N/A	50	50	28	N/A	68	67	48	48
	10	16	1	N/A	N/A	45	45	23	N/A	63	62	43	43

## GAS HEAT ACCESSORIES

Input	High Altitude Pressure Switch Kit		Natural Gas to LPG/Propane Kit	LPG/Propane to Natural Gas Kit	Natural Gas High Altitude Orifice Kit	LPG/Propane High Altitude Orifice Kit
	4501 - 7500 ft.	7501 - 10,000 ft.	0 - 7500 ft.	0 - 7500 ft.	7501- 10,000 ft.	7501- 10,000 ft.
045	14A47	14A50	11K51	77W09	73W37	11K46
070	14A55	14A56	11K51	77W09	73W37	11K46
090	14A54	14A53	11K51	77W09	73W37	11K46
110	14A46	14A51	11K51	77W09	73W37	11K46

## HIGH ALTITUDE DERATE

NOTE - Units may be installed at altitudes up to 10,000 ft.

At altitudes above 4501 ft. the unit must be derated to match the manifold pressure information shown below.

Units installed at altitudes of 4501 to 10,000 ft. require a pressure switch change.

Units installed at altitudes of 7501 to 10,000 ft. require an orifice change.

See the Gas Heat Accessories table for ordering information.

NOTE - This is the only permissible derate for these units.

NOTE - In Canada, certification for installations at elevations over 4500 feet is the jurisdiction of local authorities.

Input	Gas	Manifold Pressure in. w.g.										Supply Line Pressure in. w.g. 0 - 10,000 ft.	
		0 - 4500 ft.		4501 - 5500 ft.		5501 - 6500 ft.		6501 - 7500 ft.		7501 - 10,000 ft.			
		Low Fire	High Fire	Low Fire	High Fire	Low Fire	High Fire	Low Fire	High Fire	Low Fire	High Fire	Min.	Max.
All Sizes	Natural	1.7	3.5	1.6	3.3	1.5	3.2	1.5	3.1	1.7	3.5	4.5	13.0
	LPG/Propane	4.5	10.0	4.2	9.4	4.0	9.1	3.9	8.9	4.5	10.0	11.0	13.0

# DIMENSIONS - UNIT

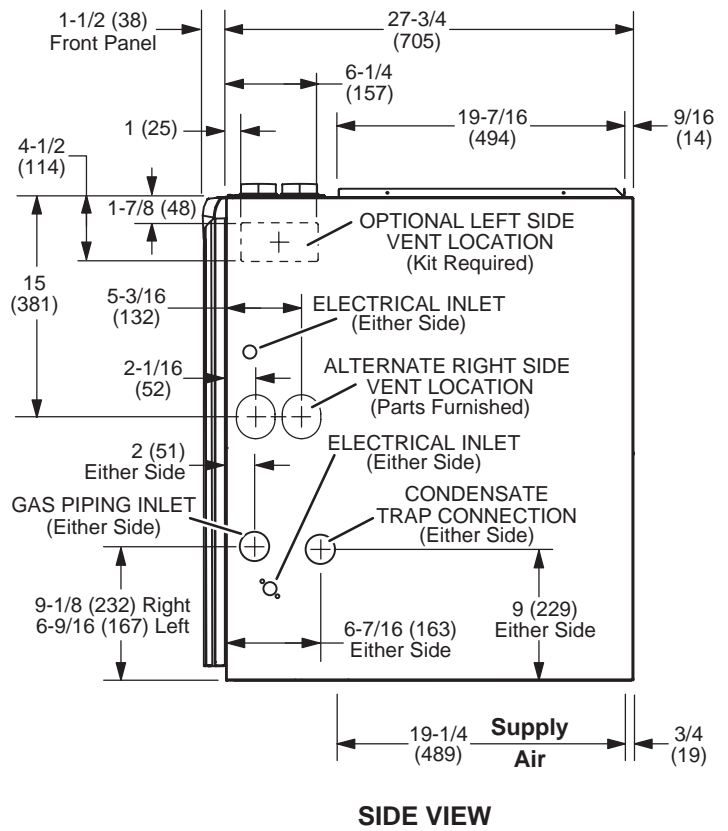
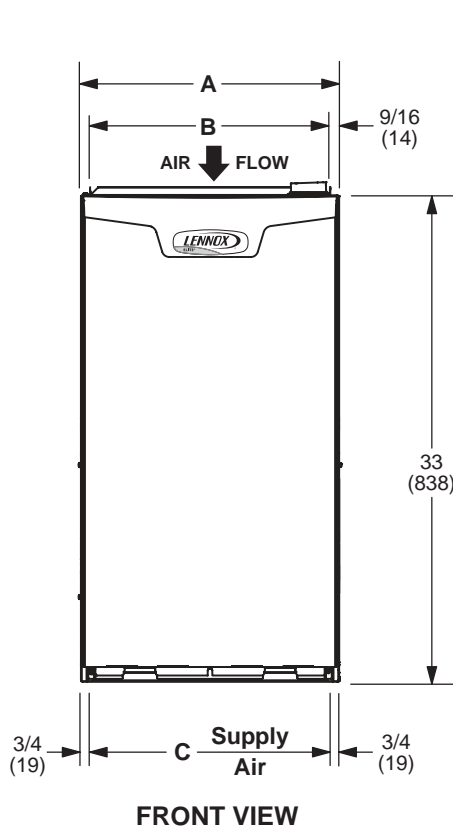
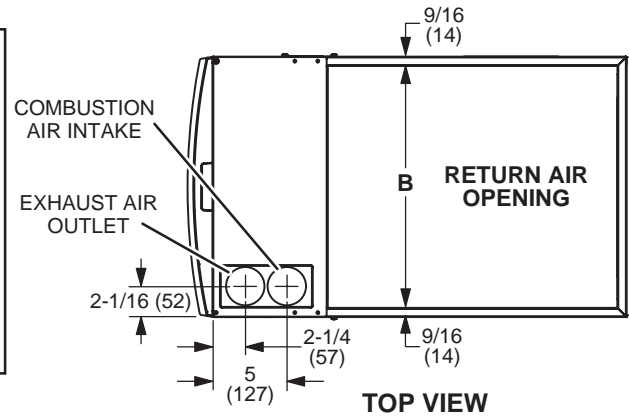
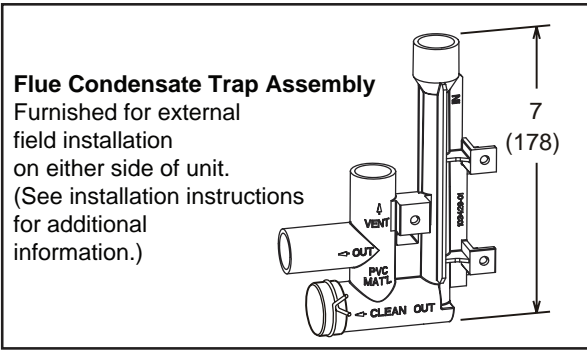

Model No.	A		B		C	
	in.	mm	in.	mm	in.	mm
EL296DF045XE36B EL296DF070XE48B	17-1/2	446	16-3/8	416	16	406
EL296DF090XE48C EL296DF110XE60C	21	533	19-7/8	505	19-1/2	495

# DIMENSIONS - OPTIONAL ACCESSORIES

## DOWNFLOW FILTER CABINET

“B AND ”C” WIDTH FURNACES  
(Two Filters)

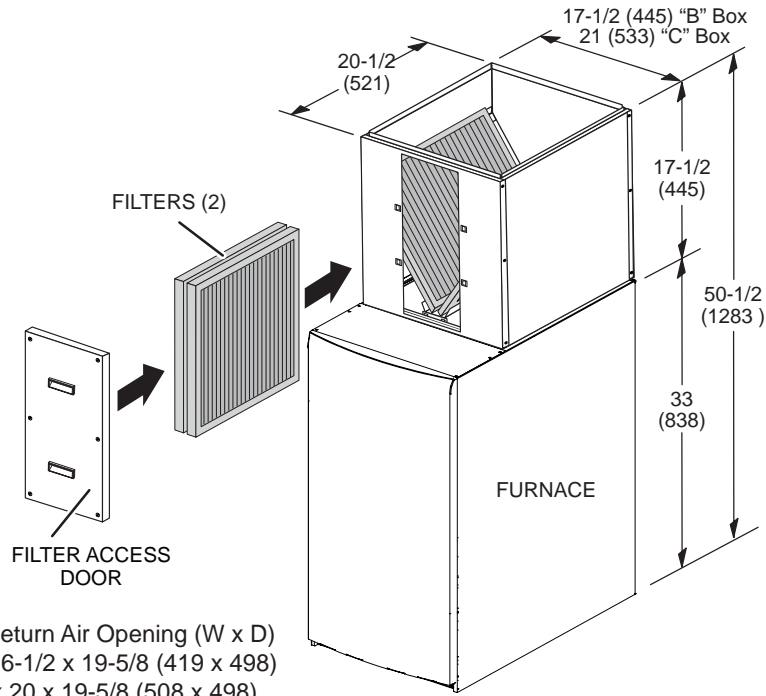

## DOWNFLOW COMBUSTIBLE FLOORING BASE

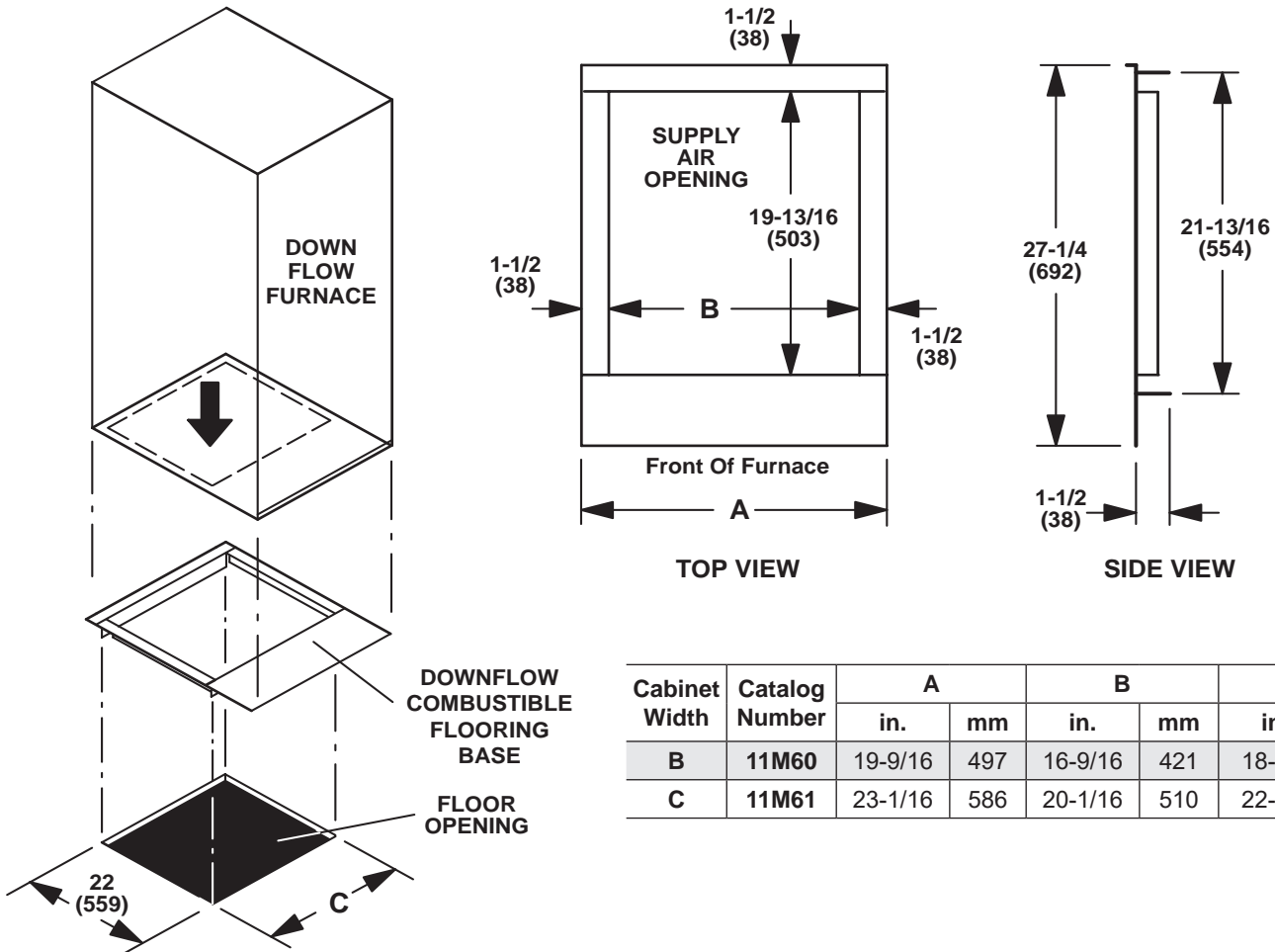

## DIMENSIONS - FURNACE/COIL COMBINED DIMENSIONS

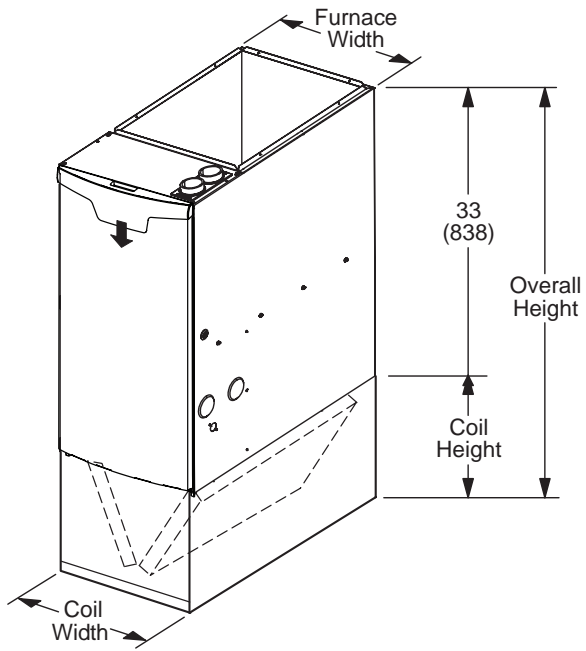

Model Number	Coil Width		Furnace Width		Coil Height		Overall Height	
	in.	mm	in.	mm	in.	mm	in.	mm
CR33-24B-F	17-1/2	446	17-1/2	446	13-1/4	337	46-1/4	1175
CR33-30/36B-F	17-1/2	446	17-1/2	446	16-1/8	410	49-1/8	1248
CR33-30/36C-F	21	533	21	533	16-1/8	410	49-1/8	1248
CR33-48B-F	21	533	17-1/2	446	20	508	53	1346
CR33-48C-F	21	533	21	533	20	508	53	1346
CR33-50/60C-F	24-1/2	622	21	533	23-5/8	600	56-5/8	2276

**FLUSH-MOUNT VENT TERMINATION KIT 51W11 (US) or 51W12 (CANADA)**

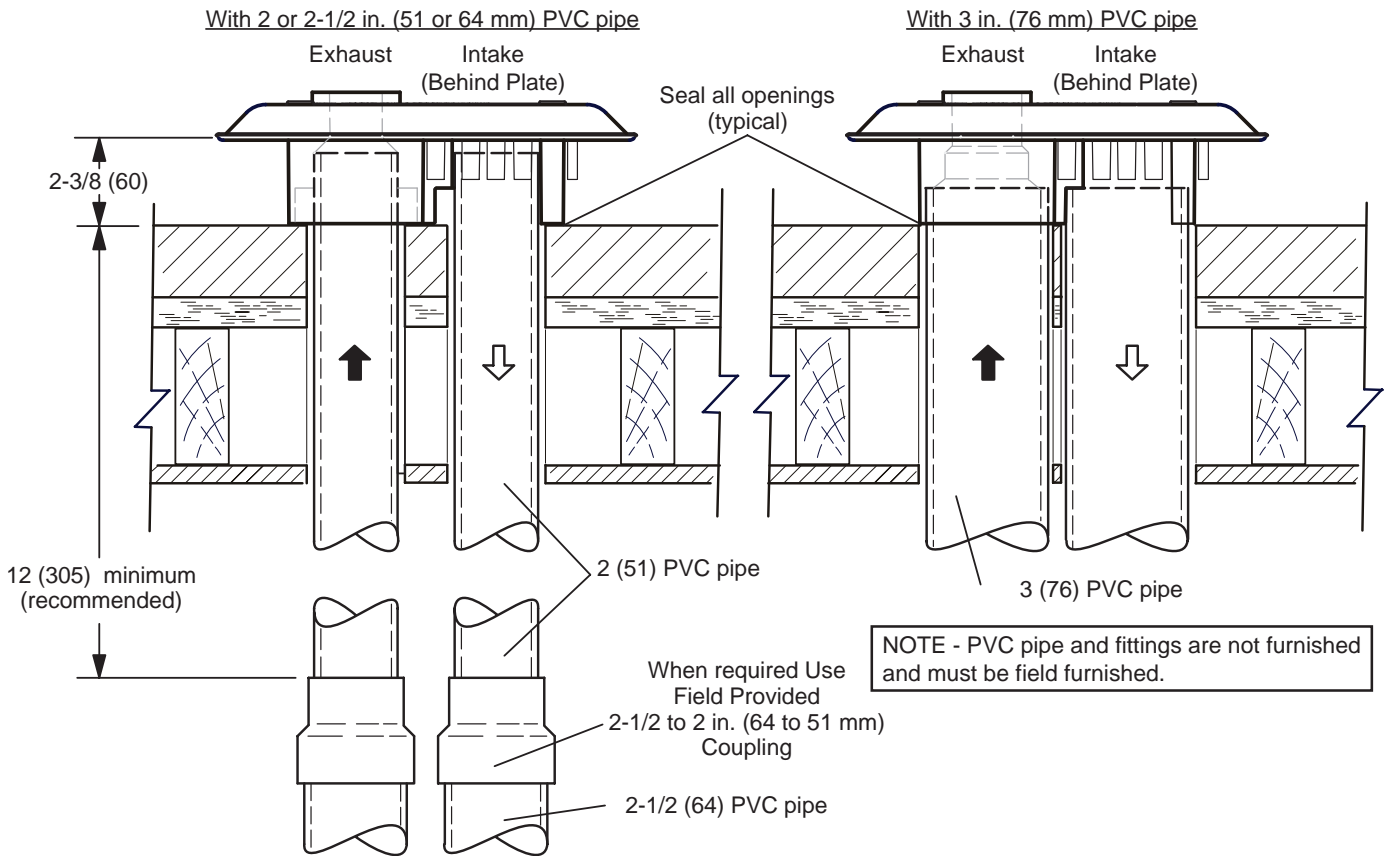
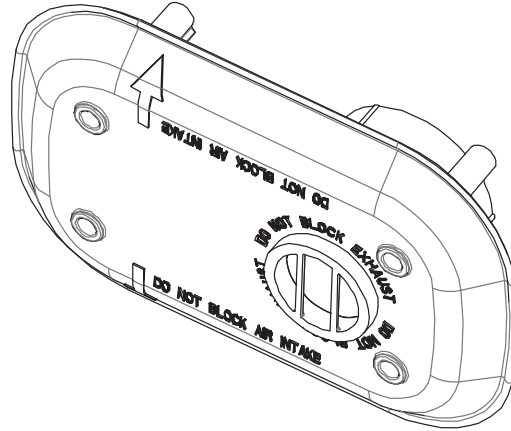



**DIMENSIONS - OPTIONAL ACCESSORIES - VENTING**

**CONCENTRIC WALL TERMINATION APPLICATIONS**

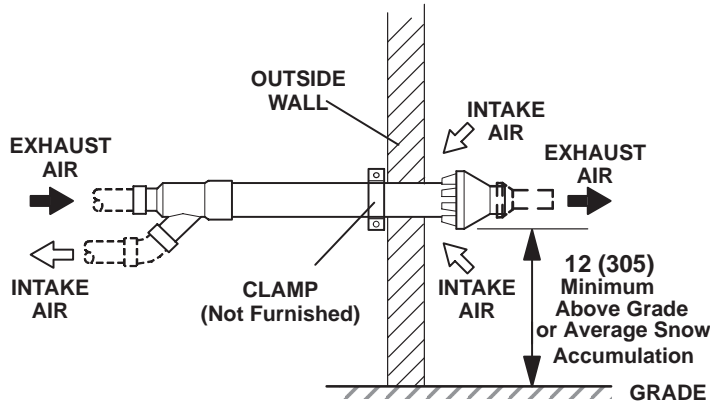

**CONCENTRIC ROOF TERMINATION APPLICATIONS**

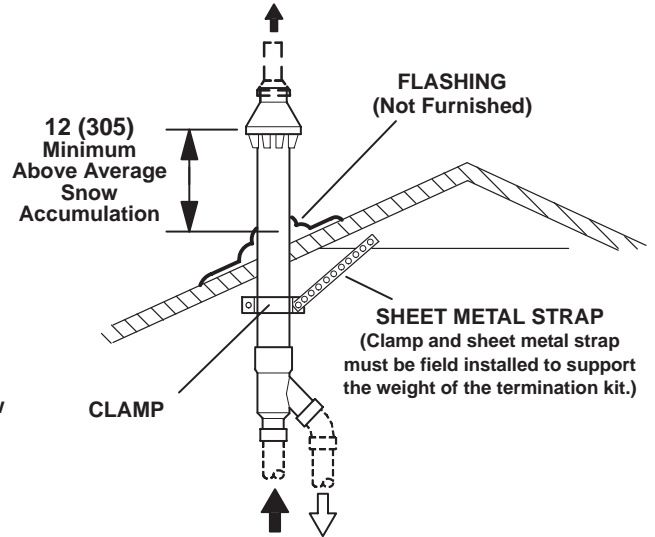

**71M80 / 69M29 / 44W92 – 2 inch kits  
60L46 / 44W93 – 3 inch kits**  
See Installation Instructions for additional information.

Note - Field provided reducer may be required to adapt different vent pipe sizes to termination.

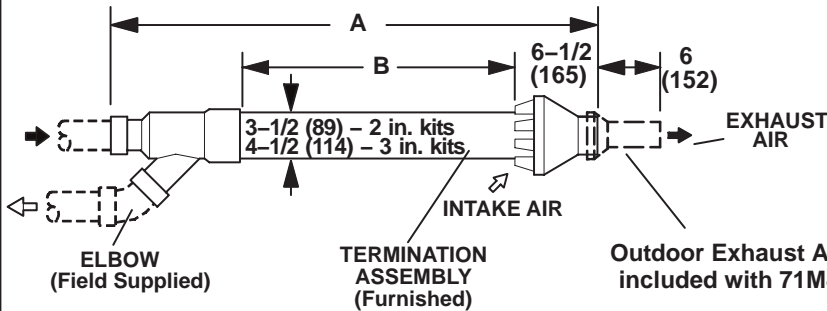

Cat. No.	A		B	
	in.	mm	in.	mm
71M80 69M29	33-3/8	848	16-3/4	425
44W92 (Canada)	29	737	15-1/2	394
60L46	38-7/8	987	21-3/16	538
44W93 (Canada)	36-1/8	918	19-1/2	495

**NOTE – Typical illustration for dimensions only. Design may vary depending on kit ordered.**

**WALL ASSEMBLY TERMINATION KIT – RING KIT 15F74 – 2 inch (51 mm)**

See Installation Instructions for additional information.

Note - Field provided reducer may be required to adapt larger vent pipe size to termination.

**DIRECT VENT APPLICATION**

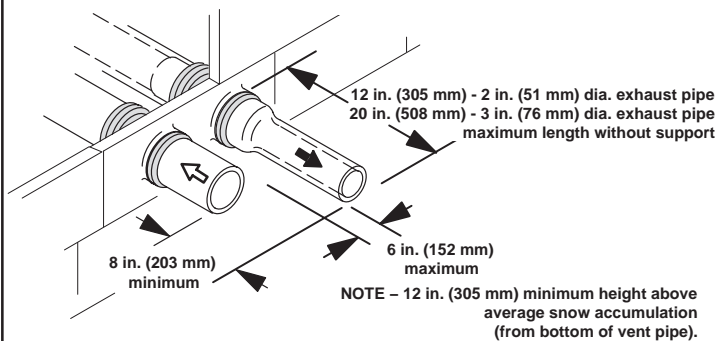

**NON-DIRECT VENT APPLICATION**

**NOTE - EXHAUST PIPE SHOWN**

Kit Contains Enough Parts For Two Installations

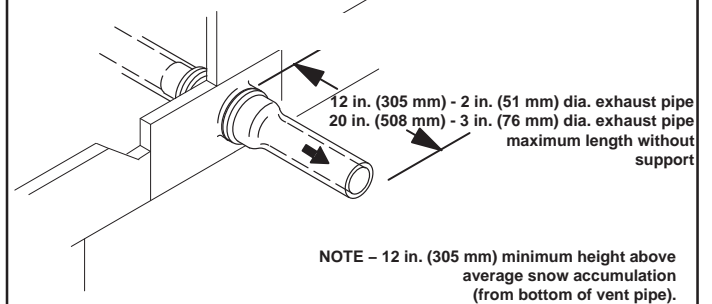

**WALL TERMINATION KITS (CLOSE-COUPLE)  
EXTENDED VENT FOR GRADE CLEARANCE  
2 inch (51 mm) 22G44 (US)  
3 inch (76 mm) 44J40 (US)**

**See Installation Instructions for additional information.**

Note - Field provided reducer may be required to adapt different vent pipe sizes to termination.

If Intake and Exhaust Pipe is less than 12 in. (305 mm) above snow accumulation or other obstructions, field fabricated piping must be installed.

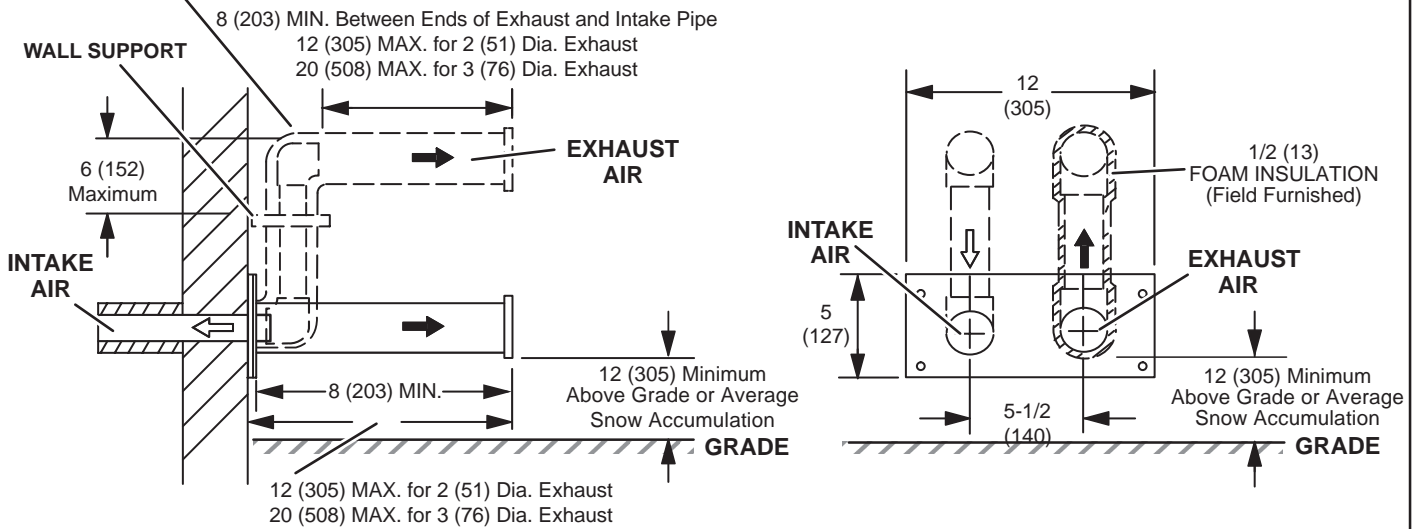

**WALL TERMINATION KITS (CLOSE-COUPLE)  
EXTENDED VENT FOR GRADE CLEARANCE  
2 inch (51 mm) 30G28 (WTK Canada)  
3 inch (76 mm) 81J20 (WTK Canada)**

**See Installation Instructions for additional information.**

Note - Field provided reducer may be required to adapt different vent pipe sizes to termination.

If Intake and Exhaust Pipe is less than 12 in. (305 mm) above snow accumulation or other obstructions, field fabricated piping must be installed.

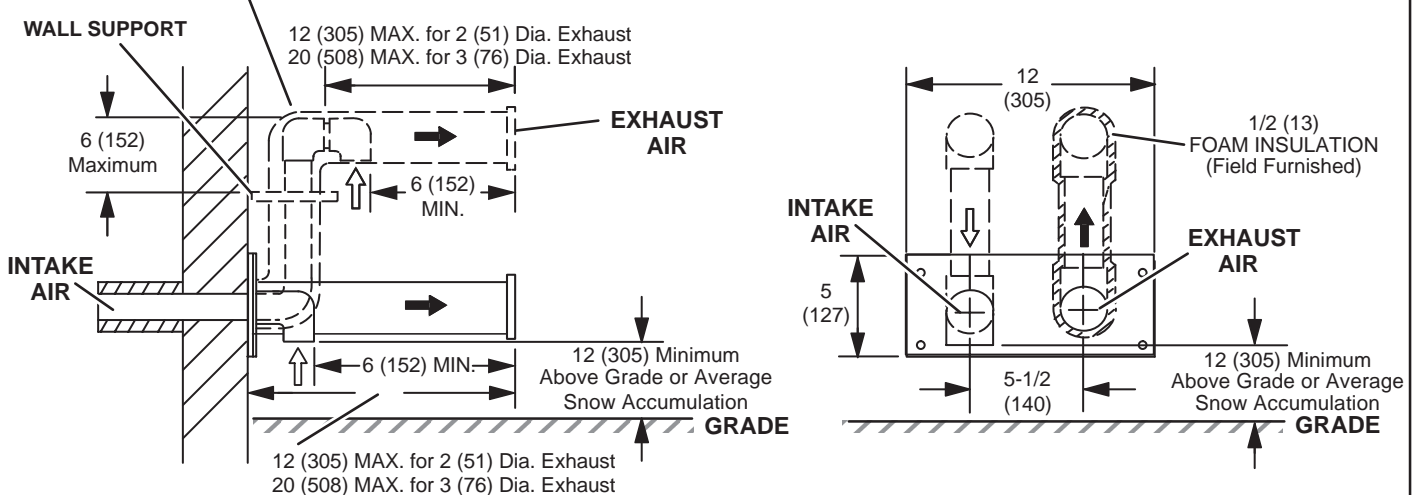

## BLOWER DATA

### EL296DF045XE36B PERFORMANCE (Less Filter)

External Static Pressure in. w.g.	Air Volume / Watts at Various Blower Speeds									
	High		Medium-High		Medium		Medium-Low		Low	
	cfm	Watts	cfm	Watts	cfm	Watts	cfm	Watts	cfm	Watts
0.00	1395	335	1290	250	1190	195	910	105	865	95
0.10	1375	350	1245	260	1140	205	875	110	815	100
0.20	1320	360	1215	265	1090	215	825	120	785	110
0.30	1285	365	1165	270	1065	225	795	130	735	115
0.40	1275	375	1150	285	1025	230	750	135	705	120
0.50	1230	385	1095	295	985	240	705	145	650	125
0.60	1185	380	1060	300	935	245	655	150	605	135
0.70	N/A	N/A	1020	310	915	250	590	150	545	140
0.80	N/A	N/A	980	315	860	255	555	160	485	140

### EL296DF070XE48B PERFORMANCE (Less Filter)

External Static Pressure in. w.g.	Air Volume / Watts at Various Blower Speeds									
	High		Medium-High		Medium		Medium-Low		Low	
	cfm	Watts	cfm	Watts	cfm	Watts	cfm	Watts	cfm	Watts
0.00	1770	510	1550	340	1355	220	1255	180	1035	115
0.10	1720	520	1510	355	1315	230	1200	185	980	105
0.20	1705	535	1470	365	1265	245	1165	195	895	110
0.30	1665	540	1430	380	1235	250	1120	205	835	120
0.40	1605	555	1390	395	1185	260	1070	210	775	130
0.50	1585	565	1335	400	1155	275	1015	225	690	140
0.60	1540	565	1300	410	1100	290	970	235	625	145
0.70	N/A	N/A	1260	420	1050	295	915	245	570	150
0.80	N/A	N/A	1220	430	1015	305	865	255	520	155

### EL296DF090XE48C PERFORMANCE (Less Filter)

External Static Pressure in. w.g.	Air Volume / Watts at Various Blower Speeds									
	High		Medium-High		Medium		Medium-Low		Low	
	cfm	Watts	cfm	Watts	cfm	Watts	cfm	Watts	cfm	Watts
0.00	1765	395	1565	265	1410	210	1290	175	1180	135
0.10	1745	410	1510	280	1365	220	1265	185	1120	140
0.20	1685	425	1455	295	1310	235	1220	200	1080	150
0.30	1630	440	1415	310	1285	250	1165	210	1035	160
0.40	1620	450	1370	320	1245	255	1125	220	985	175
0.50	1570	465	1335	330	1185	265	1080	230	925	180
0.60	1540	470	1295	345	1145	280	1045	240	875	190
0.70	N/A	N/A	1260	355	1110	295	990	255	825	200
0.80	N/A	N/A	1210	370	1060	305	940	260	760	205

### EL296DF110XE60C PERFORMANCE (Less Filter)

External Static Pressure in. w.g.	Air Volume / Watts at Various Blower Speeds									
	High		Medium-High		Medium		Medium-Low		Low	
	cfm	Watts	cfm	Watts	cfm	Watts	cfm	Watts	cfm	Watts
0.00	2285	640	1990	435	1805	330	1685	265	1480	195
0.10	2250	660	1965	450	1775	345	1630	280	1430	205
0.20	2185	675	1910	465	1720	360	1575	295	1360	215
0.30	2150	690	1850	485	1670	375	1525	310	1290	235
0.40	2085	710	1810	495	1605	395	1465	325	1255	245
0.50	2060	725	1765	515	1565	400	1420	335	1190	255
0.60	2005	745	1700	535	1510	420	1370	355	1160	270
0.70	1970	760	1665	550	1460	440	1325	370	1100	280
0.80	1910	775	1620	560	1420	450	1275	380	1045	295

## REVISIONS

Sections	Description of Change
Approvals and Warranty	Updated "California Only" section for Low NOx.
High Altitude Derate	Manifold Pressure updated for Low Fire with LPG/Propane.



Visit us at [www.lennox.com](http://www.lennox.com)

For the latest technical information, [www.LennoxPros.com](http://www.LennoxPros.com)

Contact us at 1-800-4-LENNOX

NOTE - Due to Lennox' ongoing commitment to quality, Specifications, Ratings and Dimensions subject to change without notice and without incurring liability. Improper installation, adjustment, alteration, service or maintenance can cause property damage or personal injury. Installation and service must be performed by a qualified installer and servicing agency.

©2020 Lennox Industries, Inc.