



**RESIDENTIAL
PRODUCT SPECIFICATIONS**

Bulletin No. 210647
April 2021
Supersedes November 2020



**ELITE®
SERIES**



AFUE - 96%
Input - 44,000 to 132,000 Btuh
Nominal Add-on Cooling - 1.5 to 5 Tons

MODEL NUMBER IDENTIFICATION

EL 2 96 UH 070 X E 36 B - 01

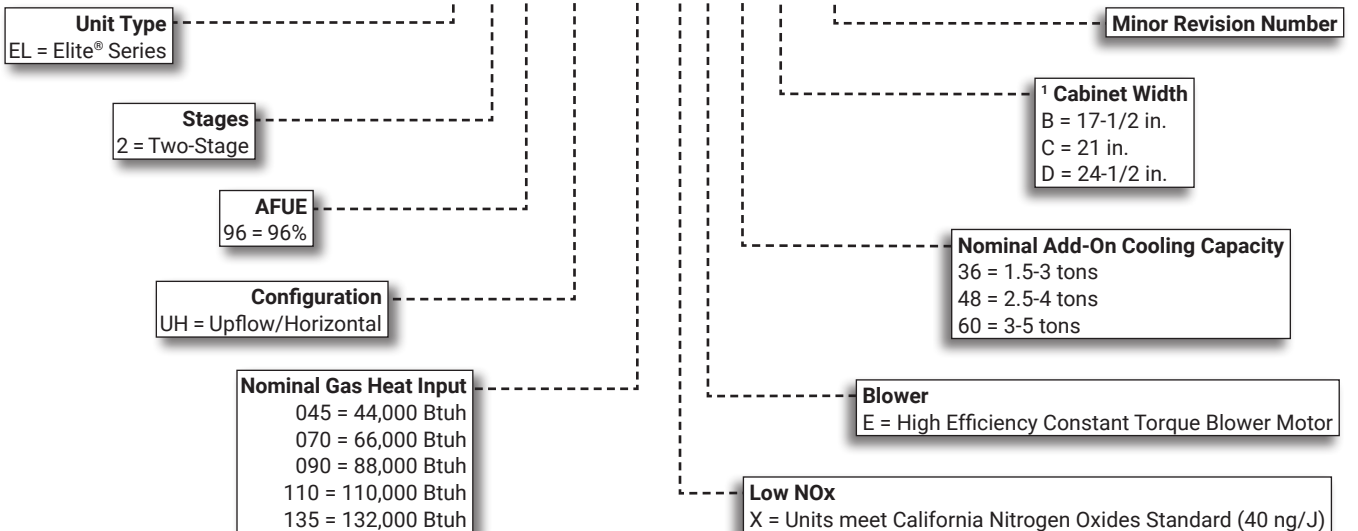

¹ Indoor coils with the same letter designation will physically match the furnace.

FEATURE HIGHLIGHTS

1. Lennox Duralok Plus™ Heat Exchanger
2. Secondary Heat Exchanger
3. Inshot Burners
4. SureLight® Hot Surface Ignitor
5. Two-Stage Gas Control Valve
6. Two-Speed Combustion Air Inducer
7. Flame Rollout Switches
8. SureLight® Integrated Furnace Control
9. Variable Speed Direct Drive Blower
10. Insulated Cabinet
11. Safety Interlock Switch
12. Gas Piping And Electrical Inlets

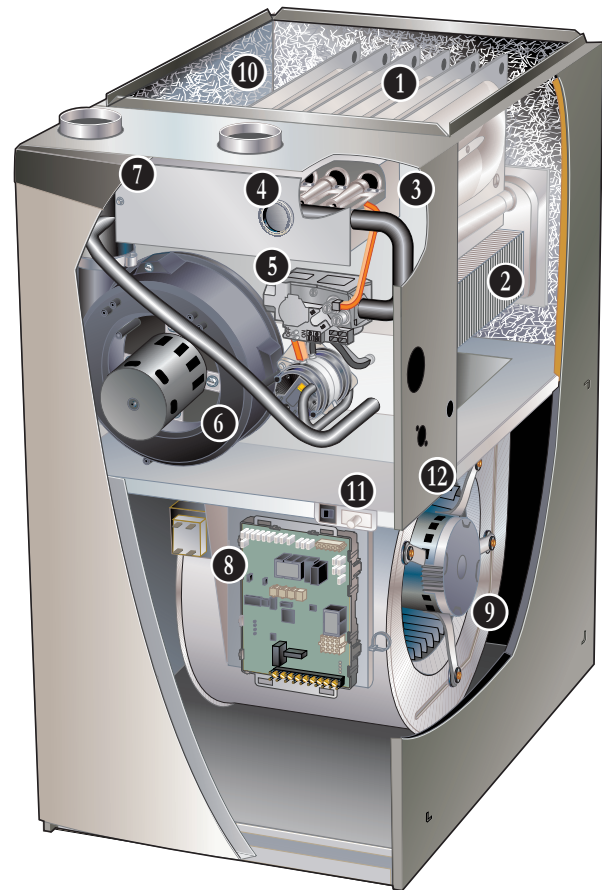

CONTENTS

Approvals And Warranty	3
Blower Data	22
Dimensions	15
- Unit - Upflow Position	15
- Unit - Horizontal Position	16
- Optional Accessories	17
- Optional Accessories - Venting.	18
- Furnace/Coil Combined Dimensions	21
Features	3
Gas Heat Accessories	11
High Altitude Derate	11
Installation Clearances	14
Model Number Identification.	1
Optional Accessories - Order Separately	10
Specifications	9
Vent Lengths	13
Vent Lengths - Uninsulated Exhaust Pipe In Unconditioned Space	12

APPROVALS AND WARRANTY

APPROVALS

- AHRI Certified
- CSA International Certified
- Tested and rated according to US DOE test procedures and FTC labeling regulations
- Units are approved for installations from 0 - 4500 ft.
- ENERGY STAR® certified units are designed to use less energy, help save money on utility bills, and help protect the environment
- ISO 9001 Registered Manufacturing Quality System
- Blower data from unit tests conducted in Lennox Laboratory air test chamber

California Only

- These furnaces **do not meet** the South Coast Air Quality Management District (SCAQMD) Rule 1111 and San Joaquin Valley Air Pollution Control District (SJVAPCD) Rule 4905 NOx emission limit (14 ng/J) and cannot be installed within the SCAQMD and SJVAPCD areas
- These furnaces are approved by the California Energy Commission and meets California Nitrogen Oxides Standard (NOx) limits of 40 ng/J

WARRANTY

- Duralok Plus™ Aluminized Steel Heat Exchanger:
 - Limited lifetime (twenty year transferable) in residential applications
 - Limited ten years in non-residential applications
- All other covered components:
 - Limited five years in residential installations
 - Limited one year in non-residential installations

NOTE - Refer to Lennox Equipment Limited Warranty certificate included with unit for specific details.

FEATURES

APPLICATIONS

- Input capacities of 44,000, 66,000, 88,000, 110,000 and 132,000 Btuh
- Energy efficiency (AFUE) - 96%
- Compact cabinet for upflow, horizontal-left or horizontal-right applications without any modifications
- Removable bottom seal panel shipped in place for side return air is easily removed for bottom/end return air applications
- Lennox add-on indoor coils, high-efficiency air cleaners and humidifiers can easily be added to furnace
- Shipped factory assembled with all controls installed and wired
- Each unit factory test operated to ensure proper operation

HEATING SYSTEM

- 1 **Lennox Duralok Plus™ Heat Exchanger Assembly**
 - Lennox developed heat exchanger assembly consists of primary heat exchanger and secondary condenser coil assembly
 - Main multi-pass crimped seam design clamshell type
 - Constructed of heavy-gauge, aluminized steel
 - Designed for normal expansion and contraction with maximum efficiency and minimum resistance to air flow
- 2 **Secondary heat exchanger condenser coil constructed of aluminum fins fitted to stainless steel tubes**
 - Coil is factory tested for leaks
 - Condensate drain header box assembly located on front of coil
 - Compact size permits low overall design of furnace cabinet
 - Laboratory life cycle tested in excess of industry standards

FEATURES

HEATING SYSTEM (continued)

Lennox Designed Header Box

- Header box on end of condenser coil collects flue condensate for disposal through condensate drains
- Drains are located on each side of the cabinet for easy field installation of condensate drain trap
- Only one drain is used, the other drain is sealed
- Condensate drain trap is included with the unit for field installation

Lennox Designed Flue Condensate Trap Assembly

- Field installed outside the conditioned air stream
- Assembly can be mounted on either side of cabinet in upflow applications
- Assembly is mounted below the cabinet in horizontal applications
- Can also be mounted remotely (up to 5 ft. away) from unit
- See installation instructions
- 90° street elbow furnished for ease of drain trap installation
- Drain connection can be made with field provided PVC pipe, PVC coupling, or vinyl tubing with hose clamp
- Drain cap on trap allows easy cleaning and winterizing

3 Inshot Burners

- Aluminized steel inshot burners provide efficient, trouble-free operation
- Burner venturi mixes air and gas in correct proportion for proper combustion
- Burner assembly can be removed from the unit as a single component for ease of service

4 SureLight® Hot Surface Ignitor

- Tough, reliable, long-life, trouble-free performance
- Silicon nitride ignitor
- Cemented to steatite block for protection against current leakage
- Ignition leads are constructed of nickel plated copper and are enclosed in high temperature Teflon® insulation for dependable operation

5 Two-Stage Gas Control Valve

- 24 volt redundant combination two-stage gas control valve combines manual shut off switch (On-Off), automatic electric valve (dual) and gas pressure regulation into a compact combination control

6 Two-Speed Combustion Air Inducer

- Permanent split capacitor (PSC), heavy duty blower prepurges heat exchanger and safely vents flue products
- Operates only during heating cycle
- Dual pressure switches (low fire/high fire) prove blower operation before allowing gas valve to open
- Direct access allows inducer assembly to be rotated 90° clockwise or counterclockwise to facilitate easy vent attachment in horizontal applications

7 Flame Rollout Switches (2)

- Factory installed on burner box
- Switch provides protection from abnormal operating conditions
- Manual reset

Limit Control

- Primary limit is accurately located on vestibule panel
- Automatic reset

Optional Accessories

High Altitude Orifice Kits

- Required on all units for proper unit operation at altitudes from 7501 to 10,000 ft.
- Available for natural gas and LPG/propane

High Altitude Pressure Switch Kit

- Required for proper unit operation on installations above 4500 ft.

Natural Gas to LPG/Propane Conversion Kit

- Required for field changeover from natural gas to LPG/Propane

LPG/Propane to Natural Gas Conversion Kit

- Required for field changeover from LPG/Propane to natural gas

Muffler (US Only)

- Significantly reduces outdoor operating sound levels
- Two-inch diameter muffler is optional for 045 through 110 input models

NOTE - Two-inch muffler is optional for the 110 input model with a maximum vent pipe length of up to 29 ft. Three-inch diameter muffler is optional for 110 and 135 input models.

NOTE - Three-inch muffler is optional for the 110 input model with a minimum vent pipe length of 30 ft.

- Installed vertically in the exhaust piping
- See Optional Accessory Dimension Drawing

DIRECT VENT / NON-DIRECT VENT SEALED COMBUSTION SYSTEM

- Furnace features a "sealed combustion" system and can be installed in either Direct Vent or Non-Direct applications
- In Direct Vent applications, combustion air is supplied from outdoors and flue gases are discharged outdoors
- In Non-Direct Vent applications, combustion air is supplied from indoors and flue gases are discharged outdoors

NOTE - Lennox has approved the use of DuraVent® PolyPro® and Centrotherm InnoFlue® manufactured vent pipe and terminations as an alternative to PVC vent pipe. Must be ordered separately.

- Tested and listed to the ULC S636 standard in Canada

FEATURES

DIRECT VENT / NON-DIRECT VENT SEALED COMBUSTION SYSTEM (continued)

- The polypropylene venting system must follow the uninsulated and unconditioned space vent lengths listed in the table on 12
- Refer to the Installation Instructions for additional details

Flue Coupling

- Assists with exhaust flue piping connection and servicing
- Includes flexible one 2 inch rubber coupling and two adjustable bands
- Approved for all Lennox 90% furnaces

Termination Kits

- Facilitates installation of combustion air intake pipe and flue exhaust pipe
- Refer to venting table in this bulletin to determine pipe size needed and proper termination kit required
- Certain Termination Kits are certified to ULC S636 standard for use in Canada only
- See Optional Accessories table and dimension drawings

Concentric - Direct Vent Applications

- 2 or 3 inch kit contains concentric termination assembly, reducer bushing and 45 degree elbow
- 2 inch kit for -045-070 models contains an outdoor exhaust accelerator
- Kit requires single hole penetration of roof or wall for installation
- Roof Termination Flashing Kit is available for use with 2 inch Kits
- CSA certified

Flush-Mount

- Kit contains flush-mount termination, accelerator, mounting template and hardware
- Kit may be used with 2, 2-1/2 or 3 in. pipe

Wall Assembly

Close Couple (US Only) - Direct Vent Applications

- 2 or 3 inch kit consists of close-couple, side-by-side PVC piping with galvanized steel wall cover plate for sealing and isolating piping penetration of the wall
- Piping spacing and length is sized for proper wall installations
- CSA certified

Close Couple WTK (Canada Only) - Direct Vent Applications

- 2 or 3 inch kit contains one insulated faceplate, one insulated exhaust pipe, elbow and fittings. Certified to ULC S636 standard

NOTE - Maintain a maximum of 6 inches between the inlet and outlet openings in the installation of the pipes.

Roof Termination Flashing Kit

- For vertical venting through a roof
- 2 or 3 inch kit contains two neoprene rubber roof flashings
- Vent pipe and insulation not furnished
- Flashing Kit can also be used with Concentric Vent Termination Kits used in vertical venting rooftop applications

CONTROLS

8 SureLight® Integrated Furnace Control

- Contains all necessary controls and relays to operate furnace
- Combustion air inducer is operated by the integrated furnace control
- Prior to ignition, a pre-purge cycle for 15 seconds is initiated
- After the main burners are turned off, a post-purge cycle for 5 seconds is run
- **Safety Controls** - Flame sensor utilizes flame rectification for safe and reliable operation
- Should loss of flame occur, the integrated furnace control will initiate 4 re-attempts at ignition before locking out unit operation for 60 minutes
- Watchguard type circuit automatically resets ignition controls after one hour of continuous thermostat demand after unit lockout, eliminating nuisance calls for service
- **Thermostat Control** - For optimal performance, the use of a high-quality, digital two-stage thermostat with adjustable settings for first stage/second stage, on/off differentials and adjustable stage timers is recommended

Furnace Input Staging Options

Thermostat Type	Input Staging Available
Two-Stage (Conventional)	Determined by thermostat demand
Single-Stage (Conventional)	2nd-stage heat ON delay (DIP switch setting) OFF - 7 minutes (factory) ON - 12 minutes

- **Display LED** - Seven segment LED displays alpha-numeric information related to diagnostics as well as system operation and status
- Diagnostic codes are held in non-volatile memory, immune from power interruptions
- Holds up to ten diagnostic codes in order of occurrence for recall on demand
- Port on blower door allows for easy viewing

DIP Switch Settings

- **Select Thermostat Used** - Single-Stage or Two-Stage
- Two selectable second stage recognition times (7 and 12 minutes) are available on the control when the furnace is used with a single-stage thermostat

FEATURES

CONTROLS (continued)

- When used with a two-stage thermostat, furnace will only initiate second stage operation with a second stage thermostat demand
- **Second Stage Delay** - Used with single-stage thermostat only. See Furnace Input Staging Options table for details
- **Blower On/Off Time (Heating)** - Blower on time is fixed at 30 seconds, blower off time is adjustable from 60, 90, 120 and 180 seconds (factory setting - 90 seconds)
- **Blower On/Off Time (Cooling)** - For air-conditioning applications, blower "on" time is 2 seconds following thermostat demand for cooling
- Blower "off" time in cooling mode is adjustable from 2 or 45 seconds (factory setting - 45 seconds)
- For air-conditioning applications, blower is automatically energized on thermostat demand for cooling
- **Heating Speeds** - Low Heat or High Heat
- **Cooling Speeds** - Low Cool or High Cool
- **Continuous Speed** - Low Heat (factory setting) - adjustable
- **Dehumidification** - A jumper on the control must be clipped to enable dehumidification
- A humidity controlling thermostat or device is also required
- During a call for cooling, air volume is automatically reduced, forcing humidity removal by the air conditioner or heat pump system (single stage units or two-stage units running at 2nd stage)
- After the humidity has reached the desired set-point the cooling air volume returns to its designed rate
- **Dual-Fuel Operation** - A jumper on the control must be clipped to enable operation with a single or two-stage heat pump
- The indoor blower is started without delay when a call for heat is received
- **Two-Stage Compressor Operation** - A jumper on the control must be clipped to enable operation with a two-stage compressor
- **Accessory Terminal** - One accessory terminal furnished for additional power supply requirements for 120 volt (less than 1 amp) powered air cleaners
- One un-powered pair of contacts are provided for humidifier connections and may be connected to 24V or 120V
- Control is factory installed in the unit control box

24 Volt Transformer

- Furnished and factory installed in control box
- 40VA transformer has circuit breaker wired in series

Field Wiring Make-up Box

- Furnished for line voltage wiring
- Factory installed internally on left side of furnace
- Box may be installed internally or externally on either side of furnace

Optional Accessories

iComfort® E30 Smart Wi-Fi Thermostat

- Wi-Fi enabled, electronic 7-day, universal, multi-stage, programmable, touchscreen thermostat
- 3 Heat/2 Cool
- Auto-changeover
- Controls dehumidification during cooling mode and humidification during heating mode
- Offers enhanced capabilities including humidification / dehumidification / dewpoint measurement and control, Humiditrol® control, and equipment maintenance reminders
- Easy to read 7 in. color touchscreen (measured diagonally)
- LCD display with backlight shows the current and set temperature, time, inside relative humidity, system status (operating mode and schedules) and outside temperature (optional outdoor sensor required)
- Smooth Setback Recovery starts system early to achieve setpoint at start of program period
- Compressor short-cycle protection (5 minutes)
- Up to four separate schedules are available plus Schedule IQ™
- One-Touch Away Mode - A quick and easy way to set the cooling and heating setpoints while away
- Smart Away™ - Uses geo-fencing technology to determine when the homeowner is within a predetermined distance from the home to operate the system when leaving, away and arriving
- Wi-Fi remote monitoring and adjustment through a home wireless network for desktop PCs, laptops and apps for smartphones or tablets
- Smart home automation compatible with Apple HomeKit™, Amazon Alexa®, Google Assistant and IFTTT
- Service Dashboard features online real-time monitoring of installed iComfort® Communicating systems
- High Definition Color Display with Subbase, Smart Hub Controller, wallplate (for retrofit installations) furnished for easy installation
- See the iComfort® E30 Smart Wi-Fi Thermostat Product Specifications bulletin for more information



Remote Outdoor Temperature Sensor

- iComfort® E30 Smart Thermostat
- When installed outdoors, sensor allows thermostat to display outdoor temperature



NOTE - Sensor is required for Enhanced Dehumidification Control (EDA) applications.

NOTE - The outdoor sensor is furnished as standard with iComfort® Communicating outdoor units, optional for conventional units.

FEATURES

CONTROLS (continued)

Thermostat

- Thermostat is not furnished with unit
- See Lennox Price Book for selection

Furnace Twinning Kit

- Required to operate two furnaces simultaneously.
- Kit consists of twinning relays, quick connect terminals and mounting hardware
- Used for two-stage heating/single-stage cooling with either a single-stage or two-stage thermostat

Night Service Kit

- Contains most commonly used service parts
- Furnace control
- Gas valve
- Ignitor
- Transformer
- Flame sensor
- Service manual

Blower Relay Kit

- For use with two-stage outdoor units
- Allows furnace blower speed changes when matched with two-stage air conditioners or heat pumps

BLOWER

- Direct drive blower
- Statically and dynamically balanced
- Resiliently mounted
- Blower assembly easily removed for servicing

9 Power Saver™ Constant Torque Blower Motor

- DC Brushless Motor
- High Efficiency Constant Torque
- ECM (Electronically Commutated Motor)
- Motor is programmed to provide constant torque at each of the selectable speeds
- Motor is controlled by the SureLight® Integrated Furnace Control
- Blower speeds are easily changed on the integrated furnace control
- See Blower Data tables

CABINET

- Low-profile, narrow width allows easy installation
- Heavy-gauge, cold rolled steel construction
- Pre-painted cabinet finish
- Flanges provided on supply air opening for ease of plenum connection or alignment with indoor coil
- 10 • Insulated with foil faced insulation on sides and back of heating compartment and mat faced insulation in blower compartment
- Sealed blower compartment
- Inner blower compartment access panel seals blower compartment from air leakage
- Cabinet door can be removed without any tools
- Complete service access
- 11 • Safety interlock switch automatically shuts off power to unit when blower compartment access door is removed
- 12 • Gas piping and electrical inlets are provided in both sides of cabinet

Bottom/Side Return Air Entry:

- Upflow/horizontal with bottom return air entry:
 - Remove furnished bottom seal panel from cabinet
- Upflow only with side return-air entry:
 - Corners are marked on either side of cabinet for return air cut-out
- See dimension drawings

NOTE - 60C and 60D size units that require air volumes over 1800 cfm must have one of the following:

1. Single side return air and Optional Return Air Base with transition that must accommodate required 20 x 25 x 1 inch air filter to maintain proper velocity
 2. Bottom return air
 3. Return air from both sides
 4. Bottom and one side return air
- See Blower Performance Tables for additional information

Coil Match-Up

- All furnaces exactly match Lennox cased upflow indoor coils and horizontal indoor coils with same letter designation (A, B, C, D) in model number
- No adaptor required
- Engaging holes furnished on cabinet for alignment
- Lennox uncased coils match furnaces without any overhang but require an optional adaptor base or field fabricated transition to match furnace opening
- See coil bulletin for additional information

Low Leakage Cabinet

- All models have less than 2% air leakage
- Meets ANSI/ASHRAE Standard 193-2010 "Method of Test for Determining the Air Tightness of HVAC Equipment"

FEATURES

CABINET (continued)

Optional Accessories

Condensate Drain Heat Cable Kits

- Self-limiting wattage heat cable prevents condensate drain from freezing in unconditioned areas
- Available in 6 or 24 ft. lengths

Horizontal Suspension Kit

- Provides suspension of unit and indoor coil in horizontal applications
- Allows complete service access
- Consists of corner mounted hanging brackets with vibration isolators, return air end support rail and hardware for assembly
- Metal hanging straps must be field provided

Crawl Space Vent Drain Kit

- Allows venting through a crawl space for upflow and horizontal applications
- Kit for Canada is certified to ULC S636
- Includes 2 or 3 inch sanitary tee, 2 inch PVC assembly, PVC boot and clamp

Return Air Base

NOTE - On furnaces with side return air and condensate trap on the same side of the cabinet, a field fabricated transition or Return Air Base is required when using an IAQ product higher than 14-3/16 inches installed next to the unit and serviced from the front. IAQ products higher than 20 inches require a field fabricated transition.

NOTE - Must be used for 60C and 60D size models with air volumes over 1800 cfm in upflow applications when only one side return is required.

- Cabinet is shipped flat for easy field assembly
- Pre-painted steel to match the furnace
- See Dimension Drawing

High Performance Economizer (Commercial Applications Only)

- Designed for applications requiring outdoor air to be utilized in a commercial HVAC system
- Allows the entry of fresh outdoor air for free cooling, reducing the requirement for mechanical cooling
- Heavy gauge galvanized steel cabinet lined with thick fiberglass insulation
- Mixed air sensor, outdoor air sensor and 24VAC transformer furnished
- Approved for California Title 24 building standards. ASHRAE 90.1-2010 compliant
- See separate Product Specifications bulletin for additional information and available control and sensor options

FILTER (not furnished)

- Filter and provisions for external mounting must be field provided

Optional Accessories

Air Filter and Rack Kit for Horizontal Return Air (End) Applications

- Washable or vacuum cleanable polyurethane frame type filter and external end return air rack
- Rack has filter door for servicing
- Flanges on rack for duct connection
- Field installed
- See dimension drawing

Air Filter and Rack Kit for Upflow Side Return Air

NOTE - Not for use with Return Air Base

- Washable or vacuum cleanable polyurethane frame type filter and external side return air rack available for field installation
- Available in single and ten pack kits
- Rack has filter door for servicing
- Flanges on rack for duct connection
- Field installs on either side of unit cabinet
- See dimension drawing

SPECIFICATIONS

Gas	Model No.	EL296UH045XE36B	EL296UH070XE36B	EL296UH090XE48C	
Heating Performance	AHRI Ref. No.	5625717	5625718	5625719	
	¹ AFUE	96%	96%	96%	
	High Fire	Input - Btuh	44,000	66,000	88,000
		Output - Btuh	43,000	64,000	84,000
		Temperature rise range - °F	30-60	35-65	40-70
		Gas Manifold Pressure (in. w.g.) Nat. Gas / LPG/Propane	3.5 / 10.0	3.5 / 10.0	3.5 / 10.0
	Low Fire	Input - Btuh	29,000	43,000	57,000
		Output - Btuh	28,000	42,000	55,000
		Temperature rise range - °F	20 - 50	25 - 55	30 - 60
		Gas Manifold Pressure (in. w.g.) Nat. Gas / LPG/Propane	1.7 / 4.5	1.7 / 4.5	1.7 / 4.5
High static - in. w.g.		0.5	0.5	0.5	
Connections in.	Intake / Exhaust Pipe (PVC)	2 / 2	2 / 2	2 / 2	
	Gas pipe size IPS	1/2	1/2	1/2	
	Condensate Drain Trap (PVC pipe) - i.d.	3/4	3/4	3/4	
	with furnished 90° street elbow with field supplied (PVC coupling) - o.d.	3/4 slip x 3/4 Mipt 3/4 slip x 3/4 MPT	3/4 slip x 3/4 Mipt 3/4 slip x 3/4 MPT	3/4 slip x 3/4 Mipt 3/4 slip x 3/4 MPT	
Indoor Blower	Wheel nominal diameter x width - in.	10 x 8	10 x 8	10 x 10	
	Motor Type	DC Brushless	DC Brushless	DC Brushless	
	Motor output - hp	1/2	1/2	3/4	
	Tons of add-on cooling	1.5 - 3	1.5 - 3	2.5 - 4	
	Air Volume Range - cfm	520 - 1345	550 - 1380	760 - 1740	
Electrical Data	Voltage	120 volts - 60 hertz - 1 phase			
	Blower motor full load amps	6.8	6.8	8.4	
	Maximum overcurrent protection	15	15	15	
Shipping Data	lbs. - 1 package	129	133	159	

NOTE - Filters and provisions for mounting are not furnished and must be field provided.

¹ Annual Fuel Utilization Efficiency based on DOE test procedures and according to FTC labeling regulations. Isolated combustion system rating for non-weatherized furnaces.

SPECIFICATIONS

Gas	Model No.	EL296UH110XE60C	EL296UH135XE60D	
Heating Performance	AHRI Ref. No.	5625720	5625721	
	¹ AFUE	96%	96%	
	High Fire	Input - Btuh	110,000	132,000
		Output - Btuh	106,000	127,000
		Temperature rise range - °F	40-70	45-75
		Gas Manifold Pressure (in. w.g.) Nat. Gas / LPG/Propane	3.5 / 10.0	3.5 / 10.0
	Low Fire	Input - Btuh	72,000	86,000
		Output - Btuh	70,000	84,000
		Temperature rise range - °F	30-60	35-65
		Gas Manifold Pressure (in. w.g.) Nat. Gas / LPG/Propane	1.7 / 4.9	1.7 / 4.9
High static - in. w.g.		0.5	0.5	
Connections in.	Intake / Exhaust Pipe (PVC)	2 / 2	2 / 2	
	Gas pipe size IPS	1/2	1/2	
	Condensate Drain Trap (PVC pipe) - i.d.	3/4	3/4	
	with furnished 90° street elbow with field supplied (PVC coupling) - o.d.	3/4 slip x 3/4 Mipt 3/4 slip x 3/4 MPT	3/4 slip x 3/4 Mipt 3/4 slip x 3/4 MPT	
Indoor Blower	Wheel nominal diameter x width - in.	11-1/2 x 10	11-1/2 x 10	
	Motor Type	DC Brushless	DC Brushless	
	Motor output - hp	1	1	
	Tons of add-on cooling	3 - 5	3.5 - 5	
	Air Volume Range - cfm	1055 - 2220	1260 - 2405	
Electrical Data	Voltage	120 volts - 60 hertz - 1 phase		
	Blower motor full load amps	10.9	10.9	
	Maximum overcurrent protection	15	15	
Shipping Data	lbs. - 1 package	174	189	

NOTE - Filters and provisions for mounting are not furnished and must be field provided.

¹ Annual Fuel Utilization Efficiency based on DOE test procedures and according to FTC labeling regulations. Isolated combustion system rating for non-weatherized furnaces.

OPTIONAL ACCESSORIES - ORDER SEPARATELY

			"B" Width Models	"C" Width Models	"D" Width Models
CABINET ACCESSORIES					
Horizontal Suspension Kit - Horizontal only			51W10	51W10	51W10
Return Air Base - Upflow only			50W98	50W99	51W00
High Performance Economizer (Commercial Only)			10U53	10U53	10U53
CONDENSATE DRAIN KITS					
Condensate Drain Heat Cable	6 ft.		26K68	26K68	26K68
	24 ft.		26K69	26K69	26K69
Crawl Space Vent Drain Kit	US		51W18	51W18	51W18
	Canada		15Z70	15Z70	15Z70
CONTROLS					
Blower Relay Kit (for two-stage outdoor units)			85W66	85W66	85W66
Furnace Twinning Kit			16W72	16W72	16W72
iComfort® E30 Smart Wi-Fi Thermostat			20A65	20A65	20A65
Remote Outdoor Air Temperature Sensor			X2658	X2658	X2658
Night Service Kit			10B39	10B39	10B39
FILTER KITS					
¹ Air Filter and Rack Kit	Horizontal (end)		87L96	87L97	87L98
		Size of filter - in.	18 x 25 x 1	20 x 25 x 1	25 x 25 x 1
	Side Return	Single	44J22	44J22	44J22
		Ten Pack	66K63	66K63	66K63
		Size of filter - in.	16 x 25 x 1	16 x 25 x 1	16 x 25 x 1
TERMINATION KITS					
See Installation Instructions for specific venting information.					
Direct Vent	Concentric	US - 2 in.	71M80	69M29	---
		3 in.	---	60L46	60L46
		Canada - 2 in.	44W92	44W92	---
		3 in.	---	44W93	44W93
	Flush-Mount	US - 2, 2-1/2 or 3 in.	51W11	51W11	51W11
		Canada - 2, 2-1/2 or 3 in.	51W12	51W12	51W12
	Wall - Close Couple	US - 2 in.	22G44	---	---
		3 in.	44J40	44J40	44J40
	Wall - Close Couple WTK	Canada - 2 in.	30G28	---	---
		3 in.	81J20	81J20	81J20
	Roof Termination Flashing Kit (no vent pipe - 2 flashings)	2 in.	15F75	15F75	---
		3 in.	44J41	44J41	44J41
VENTING					
Flue Coupling		2 in.	17H92	17H92	17H92

¹ Cleanable polyurethane, frame-type filter.

NOTE - Termination Kits (44W92, 44W93, 30G28, 51W12, 81J20) and Crawl Space Vent Drain Kit (15Z70) are certified to ULC S636 standard for use in Canada only.

GAS HEAT ACCESSORIES

Input	High Altitude Pressure Switch Kit		Natural Gas to LPG/Propane Kit	LPG/Propane to Natural Gas Kit	Natural Gas High Altitude Orifice Kit	LPG/Propane High Altitude Orifice Kit	Muffler (US Only)
	4501 - 7500 ft.	7501 - 10,000 ft.	0 - 7500 ft.	0 - 7500 ft.	7501 - 10,000 ft.	7501 - 10,000 ft.	
045	14A47	14A50	11K51	77W09	73W37	11K46	15Y66 (2-inch)
070	14A54	14A53	11K51	77W09	73W37	11K46	15Y66 (2-inch)
090	14A57	14A54	11K51	77W09	73W37	11K46	15Y66 (2-inch)
110	14A46	14A51	11K51	77W09	73W37	11K46	¹ 15Y66 (2-inch) 16A56 (3-inch)
135	14A49	14A51	11K51	77W09	73W37	11K46	16A56 (3-inch)

¹ Two-inch diameter muffler (15Y66) is optional for 110 input model with a maximum vent pipe length of up to 29 ft.

Three-inch diameter muffler (16A56) is optional for 110 input model with a minimum vent pipe length of 30 ft.

HIGH ALTITUDE DERATE

NOTE - Units may be installed at altitudes up to 10,000 ft.

At altitudes above 4501 ft. the unit must be derated to match the manifold pressure information shown below.

Units installed at altitudes of 4501 to 10,000 ft. require a pressure switch change.

Units installed at altitudes of 7501 to 10,000 ft. require an orifice change.

See the Gas Heat Accessories table for ordering information.

NOTE - This is the only permissible derate for these units.

NOTE - In Canada, certification for installations at elevations over 4500 feet is the jurisdiction of local authorities.

Input	Gas	Manifold Pressure in. w.g.										Supply Line Pressure in. w.g. 0 - 10,000 ft.	
		0 - 4500 ft.		4501 - 5500 ft.		5501 - 6500 ft.		6501 - 7500 ft.		7501 - 10,000 ft.			
		Low Fire	High Fire	Low Fire	High Fire	Low Fire	High Fire	Low Fire	High Fire	Low Fire	High Fire	Min.	Max.
All Sizes	Natural	1.7	3.5	1.6	3.3	1.5	3.2	1.5	3.1	1.7	3.5	4.5	13.0
	LPG/Propane	4.5	10.0	4.2	9.4	4.0	9.1	3.9	8.9	4.5	10.0	11.0	13.0

OUTDOOR TERMINATION KIT USAGE

Input Size	Vent Pipe Diameter (in.)	Standard Terminations				Concentric Terminations			
		Flush Mount Kit	Wall Kit		Field Fabricated Exhaust Accelerator Size Required	Concentric Kit			
			2 inch	3 inch		1-1/2 inch	2 inch	3 inch	
			51W11 (US) 4 51W12 (CA)	22G44 (US) 4 30G28 (CA)		44J40 (US) 4 81J20 (CA)	71M80 (US) 4 44W92 (CA)	69M29 (US) 4 44W92 (CA)	60L46 (US) 4 44W93 (CA)
045	2	³ YES	YES	¹ YES	1-1/2 in.	² YES	---	---	
	2-1/2	³ YES	YES	¹ YES	1-1/2 in.	² YES	---	---	
	3	³ YES	YES	¹ YES	1-1/2 in.	² YES	---	---	
070	2	³ YES	YES	¹ YES	1-1/2 in.	² YES	---	---	
	2-1/2	³ YES	YES	¹ YES	1-1/2 in.	² YES	---	---	
	3	³ YES	YES	¹ YES	1-1/2 in.	² YES	---	---	
090	2	³ YES	---	YES	2 in.	---	YES	YES	
	2-1/2	³ YES	---	YES	2 in.	---	YES	YES	
	3	³ YES	---	YES	2 in.	---	YES	YES	
110	2	YES	---	YES	2 in.	---	YES	YES	
	2-1/2	YES	---	YES	2 in.	---	YES	YES	
	3	YES	---	YES	2 in.	---	YES	YES	
135	3	YES	---	YES	2 in.	---	---	YES	

NOTE - Standard Terminations do not include any vent pipe or elbows external to the structure.

Any vent pipe or elbows external to the structure must be included in total vent length calculations. See Vent Length Tables.

¹ Requires field provided 1-1/2 in. outdoor exhaust accelerator.

² Concentric Kits **71M80** and **44W92** include 1-1/2 in. outdoor exhaust accelerator, required when used with 045 and 070 input models. Accelerator is not used with 090, 110, 135 input models.

³ Flush Mount Kit **51W11** and **51W12** includes 1-1/2 in. outdoor exhaust accelerator, required when used with 045, 070 and 090 input models. Accelerator is not used with 110 or 135 input models.

⁴ Termination Kits **30G28**, **44W92**, **44W93**, **51W12** and **81J20** are certified to ULC S636 standard for use in Canada only.

VENT LENGTHS - UNINSULATED EXHAUST PIPE IN UNCONDITIONED SPACE

¹ Winter Design Temperatures	Vent Pipe Diameter	Unit Input Size									
		045		070		090		110		135	
		Maximum Uninsulated Exhaust Vent Length (ft.)									
		PVC	PolyPro InnoFlue	PVC	PolyPro InnoFlue	PVC	PolyPro InnoFlue	PVC	PolyPro InnoFlue	PVC	PolyPro InnoFlue
32 to 21°F	2 in.	21	18	33	30	46	42	30	30	N/A	N/A
	2-1/2 in.	16	N/A	26	N/A	37	N/A	36	N/A	N/A	N/A
	3 in.	12	12	21	21	30	30	29	29	42	42
20 to 1°F	2 in.	11	9	19	17	28	25	27	24	N/A	N/A
	2-1/2 in.	7	N/A	14	N/A	21	N/A	20	N/A	N/A	N/A
	3 in.	N/A	N/A	9	9	16	16	14	14	23	23
0 to -20°F	2 in.	6	4	12	10	19	16	18	15	N/A	N/A
	2-1/2 in.	N/A	N/A	7	N/A	13	N/A	12	N/A	N/A	N/A
	3 in.	N/A	N/A	N/A	N/A	8	8	7	7	13	13

NOTE - Concentric terminations are equivalent to 5 ft. of straight pipe and should be included when measuring total pipe length.

¹ Refer to 99% Minimum Design Temperature table provided in the current edition of ASHRAE Handbook-Fundamentals.

PolyPro® poly-propylene vent pipe is a registered trademark of DuraVent®.

InnoFlue® is a registered trademark of Centrotherm Eco Systems.

VENT LENGTHS

STANDARD TERMINATION AT ELEVATION 0 - 4500 ft.

Pipe Size	2 in.					2-1/2 in.					3 in.					
	Input	045	070	090	110	135	045	070	090	110	135	045	070	090	110	135
No. of 90 ELL	1	81	66	44	24	N/A	115	115	93	58	N/A	138	137	118	118	114
	2	76	61	39	19	N/A	110	110	88	53	N/A	133	132	113	113	109
	3	71	56	34	14	N/A	105	105	83	48	N/A	128	127	108	108	104
	4	66	51	29	N/A	N/A	100	100	78	43	N/A	123	122	103	103	99
	5	61	46	24	N/A	N/A	95	95	73	38	N/A	118	117	98	98	94
	6	56	41	19	N/A	N/A	90	90	68	33	N/A	113	112	93	93	89
	7	51	36	14	N/A	N/A	85	85	63	28	N/A	108	107	88	88	84
	8	46	31	N/A	N/A	N/A	80	80	58	23	N/A	103	102	83	83	79
	9	41	26	N/A	N/A	N/A	75	75	53	18	N/A	98	97	78	78	74
	10	36	21	N/A	N/A	N/A	70	70	48	13	N/A	93	92	73	73	69

STANDARD TERMINATION ELEVATION 4501 - 10,000 ft.

Pipe Size	2 in.					2-1/2 in.					3 in.					
	Input	045	070	090	110	135	045	070	090	110	135	045	070	090	110	135
No. of 90 ELL	1	81	66	44	N/A	N/A	115	115	93	58	N/A	138	137	118	118	114
	2	76	61	39	N/A	N/A	110	110	88	53	N/A	133	132	113	113	109
	3	71	56	34	N/A	N/A	105	105	83	48	N/A	128	127	108	108	104
	4	66	51	29	N/A	N/A	100	100	78	43	N/A	123	122	103	103	99
	5	61	46	24	N/A	N/A	95	95	73	38	N/A	118	117	98	98	94
	6	56	41	19	N/A	N/A	90	90	68	33	N/A	113	112	93	93	89
	7	51	36	14	N/A	N/A	85	85	63	28	N/A	108	107	88	88	84
	8	46	31	N/A	N/A	N/A	80	80	58	23	N/A	103	102	83	83	79
	9	41	26	N/A	N/A	N/A	75	75	53	18	N/A	98	97	78	78	74
	10	36	21	N/A	N/A	N/A	70	70	48	13	N/A	93	92	73	73	69

CONCENTRIC TERMINATION AT ELEVATION 0 - 4500 ft.

Pipe Size	2 in.					2-1/2 in.					3 in.					
	Input	045	070	090	110	135	045	070	090	110	135	045	070	090	110	135
No. of 90 ELL	1	73	58	42	22	N/A	105	105	89	54	N/A	121	121	114	114	105
	2	68	53	37	17	N/A	100	100	84	49	N/A	116	116	109	109	100
	3	63	48	32	12	N/A	95	95	79	44	N/A	111	111	104	104	95
	4	58	43	27	N/A	N/A	90	90	74	39	N/A	106	106	99	99	90
	5	53	38	22	N/A	N/A	85	85	69	34	N/A	101	101	94	94	85
	6	48	33	17	N/A	N/A	80	80	64	29	N/A	96	96	89	89	80
	7	43	28	12	N/A	N/A	75	75	59	24	N/A	91	91	84	84	75
	8	38	23	N/A	N/A	N/A	70	70	54	19	N/A	86	86	79	79	70
	9	33	18	N/A	N/A	N/A	65	65	49	14	N/A	81	81	74	74	65
	10	28	13	N/A	N/A	N/A	60	60	44	N/A	N/A	76	76	69	69	60

CONCENTRIC TERMINATION ELEVATION 4501 - 10,000 ft.

Pipe Size	2 in.					2-1/2 in.					3 in.					
	Input	045	070	090	110	135	045	070	090	110	135	045	070	090	110	135
No. of 90 ELL	1	73	58	42	N/A	N/A	105	105	89	54	N/A	121	121	114	114	105
	2	68	53	37	N/A	N/A	100	100	84	49	N/A	116	116	109	109	100
	3	63	48	32	N/A	N/A	95	95	79	44	N/A	111	111	104	104	95
	4	58	43	27	N/A	N/A	90	90	74	39	N/A	106	106	99	99	90
	5	53	38	22	N/A	N/A	85	85	69	34	N/A	101	101	94	94	85
	6	48	33	17	N/A	N/A	80	80	64	29	N/A	96	96	89	89	80
	7	43	28	12	N/A	N/A	75	75	59	24	N/A	91	91	84	84	75
	8	38	23	N/A	N/A	N/A	70	70	54	19	N/A	86	86	79	79	70
	9	33	18	N/A	N/A	N/A	65	65	49	14	N/A	81	81	74	74	65
	10	28	13	N/A	N/A	N/A	60	60	44	N/A	N/A	76	76	69	69	60

VENT LENGTHS (EXHAUST) - VENTILATED ATTIC OR CRAWLSPACE INTAKE AIR

STANDARD TERMINATION AT ELEVATION 0 - 4500 ft.

Pipe Size		2 in.					2-1/2 in.					3 in.				
		045	070	090	110	135	045	070	090	110	135	045	070	090	110	135
No. of 90 ELL	1	71	56	34	14	N/A	100	100	78	43	N/A	118	117	98	98	94
	2	66	51	29	9	N/A	95	95	73	38	N/A	113	112	93	93	89
	3	61	46	24	4	N/A	90	90	68	33	N/A	108	107	88	88	84
	4	56	41	19	N/A	N/A	85	85	63	28	N/A	103	102	83	83	79
	5	51	36	14	N/A	N/A	80	80	58	23	N/A	98	97	78	78	74
	6	46	31	9	N/A	N/A	85	75	63	18	N/A	93	92	73	73	69
	7	41	26	4	N/A	N/A	70	70	48	13	N/A	88	87	68	68	64
	8	36	21	N/A	N/A	N/A	65	65	43	8	N/A	83	82	63	63	59
	9	31	16	N/A	N/A	N/A	60	60	38	3	N/A	78	77	58	58	54
	10	26	11	N/A	N/A	N/A	55	55	33	N/A	N/A	73	72	53	53	49

STANDARD TERMINATION ELEVATION 4501 - 10,000 ft.

Pipe Size		2 in.					2-1/2 in.					3 in.				
		045	070	090	110	135	045	070	090	110	135	045	070	090	110	135
No. of 90 ELL	1	71	56	34	N/A	N/A	100	100	78	43	N/A	118	117	98	98	94
	2	66	51	29	N/A	N/A	95	95	73	38	N/A	113	112	93	93	89
	3	61	46	24	N/A	N/A	90	90	68	33	N/A	118	107	88	88	84
	4	56	41	19	N/A	N/A	85	85	63	28	N/A	113	102	83	83	79
	5	51	36	14	N/A	N/A	80	80	58	23	N/A	98	97	78	78	74
	6	46	31	9	N/A	N/A	85	85	53	18	N/A	93	92	73	73	69
	7	41	26	4	N/A	N/A	70	70	48	13	N/A	98	87	68	68	64
	8	36	21	N/A	N/A	N/A	65	65	43	8	N/A	93	82	63	63	59
	9	31	16	N/A	N/A	N/A	60	60	38	3	N/A	78	77	58	58	54
	10	26	11	N/A	N/A	N/A	55	55	33	N/A	N/A	73	72	53	53	49

INSTALLATION CLEARANCES

Sides	¹ 0 inches (0 mm)
Rear	0 inches (0 mm)
Top/Plenum	1 inch (25 mm)
Front	0 inches (0 mm)
Front (service/alcove)	24 inches (610 mm)
Floor	² Combustible

NOTE - Air for combustion must conform to the methods outlined in the National Fuel Gas Code (NFPA 54/ANSI-Z223.1) or the National Standard of Canada CAN/CSA-B149.1 Natural Gas and Propane Installation Code[®].

NOTE - In the U.S. flue sizing must conform to the methods outlined in the current National Fuel Gas Code (NFPA 54/ANSI-Z223.1) or applicable provisions of local building codes. In Canada flue sizing must conform to the methods outlined in National Standard of Canada CAN/CSA-B149.1.

¹ Allow proper clearances to accommodate condensate trap and vent pipe installation.

² Do not install the furnace directly on carpeting, tile, or other combustible materials other than wood flooring.

DIMENSIONS

UNIT - UPFLOW POSITION

- ¹ NOTE - 60C and 60D size units that require air volumes over 1800 cfm must have one of the following:
1. Single side return air and Optional Return Air Base with transition that must accommodate required 20 x 25 x 1 inch (508 x 635 x 25 mm) air filter to maintain proper velocity.
 2. Bottom return air.
 3. Return air from both sides.
 4. Bottom and one side return air.
- See Blower Performance Tables for additional information.

² Optional Side Return Air Filter Kit is not for use with the Optional Return Air Base.

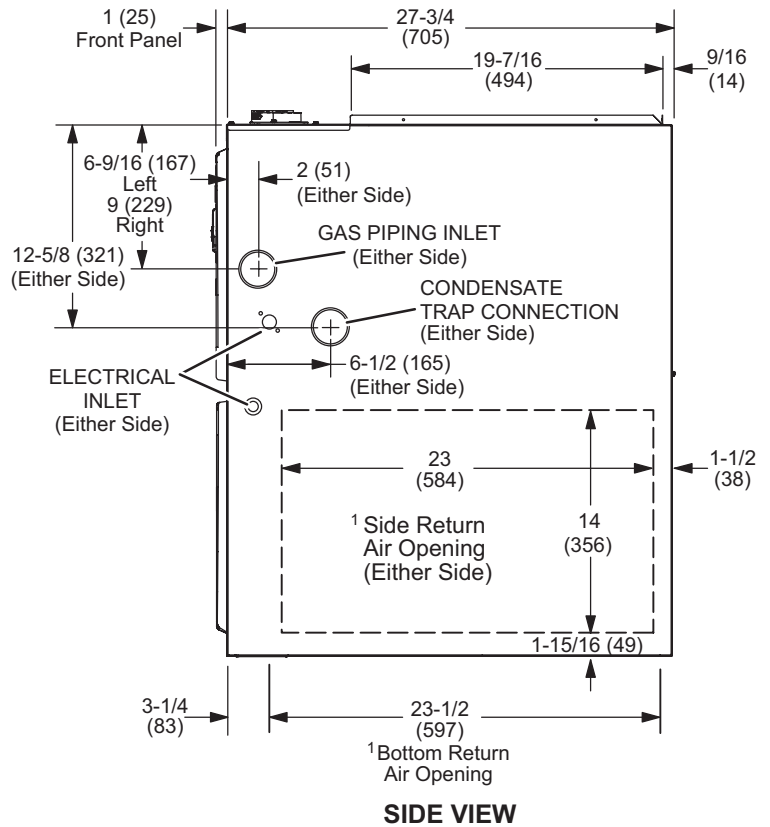
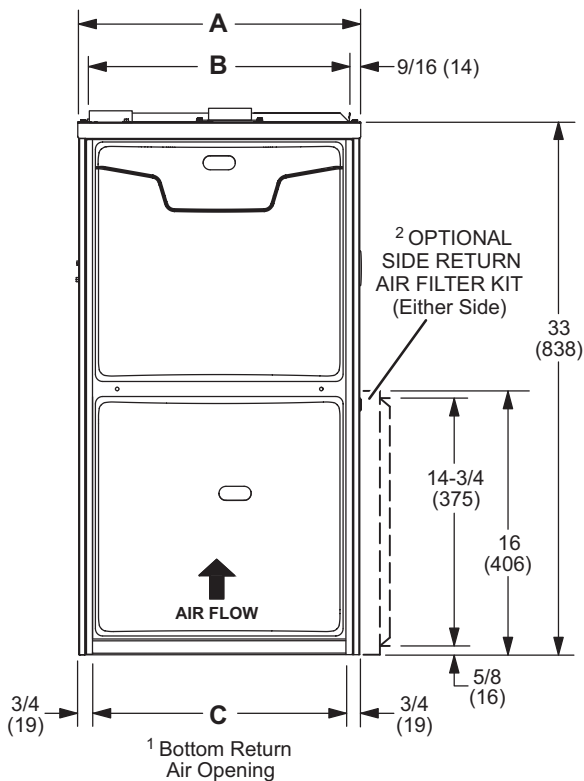
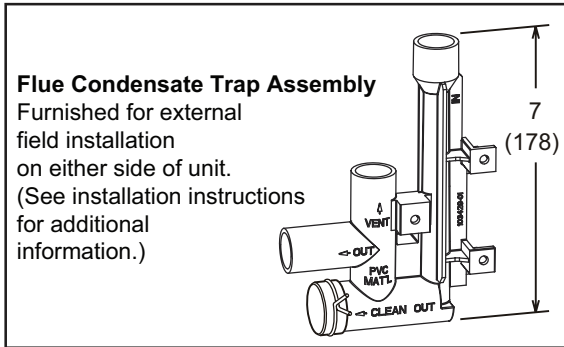
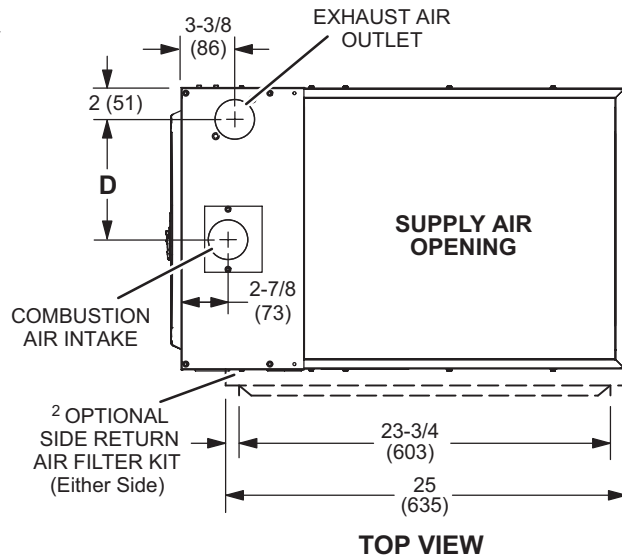

Model No.	A		B		C		D	
	in.	mm	in.	mm	in.	mm	in.	mm
EL296UH045XE36B EL296UH070XE36B	17-1/2	446	16-3/8	416	16	406	7-5/8	194
EL296UH090XE48C EL296UH110XE60C	21	533	19-7/8	505	19-1/2	495	9-3/8	238
EL296UH135XE60D	24-1/2	622	23-3/8	594	23	584	11-1/8	283

LEFT-HAND AIR DISCHARGE

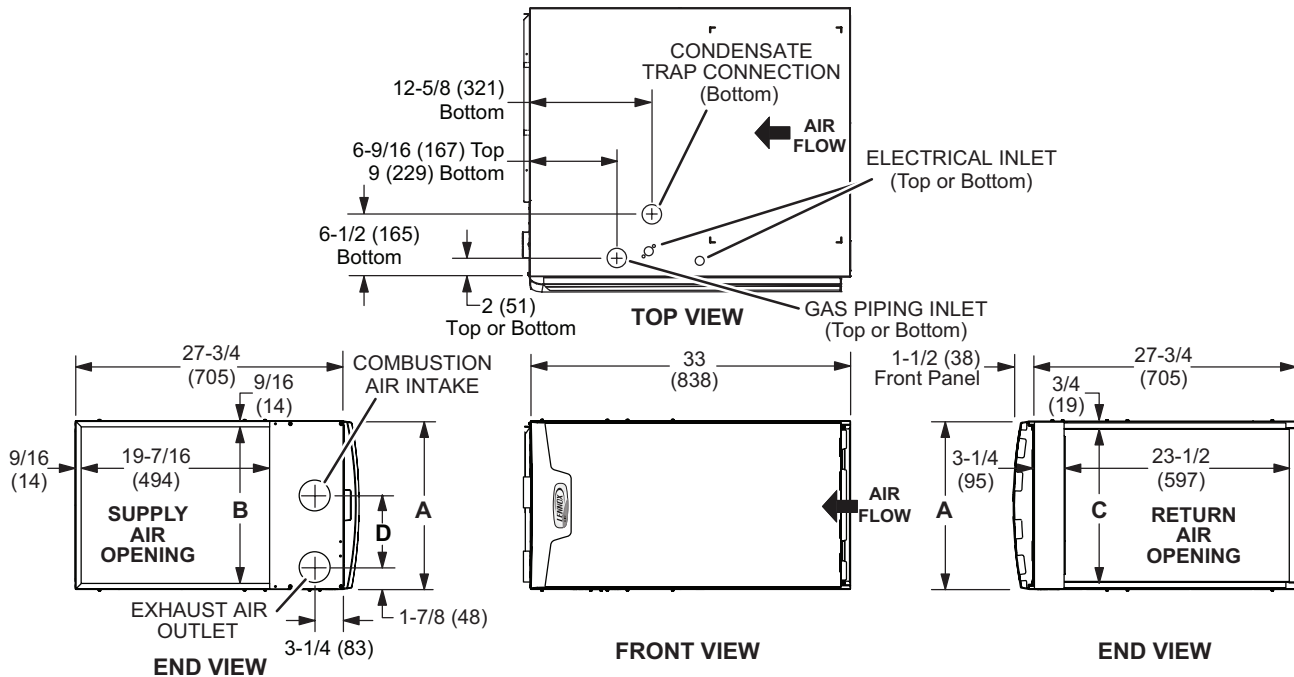

RIGHT-HAND AIR DISCHARGE

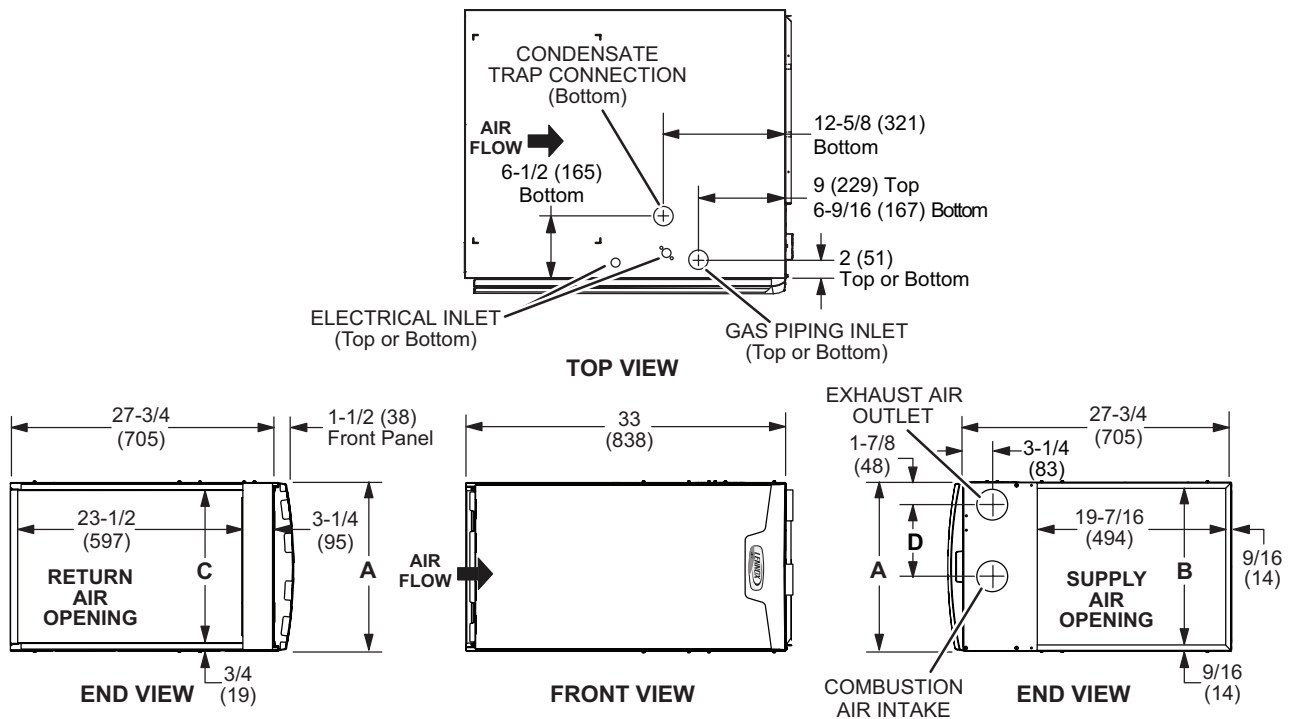

Model No.	A		B		C		D	
	in.	mm	in.	mm	in.	mm	in.	mm
EL296UH045XE36B EL296UH070XE36B	17-1/2	446	16-3/8	416	16	406	7-5/8	194
EL296UH090XE48C EL296UH110XE60C	21	533	19-7/8	505	19-1/2	495	9-3/8	238
EL296UH135XE60D	24-1/2	622	23-3/8	594	23	584	11-1/8	283

HORIZONTAL (END) FILTER KIT

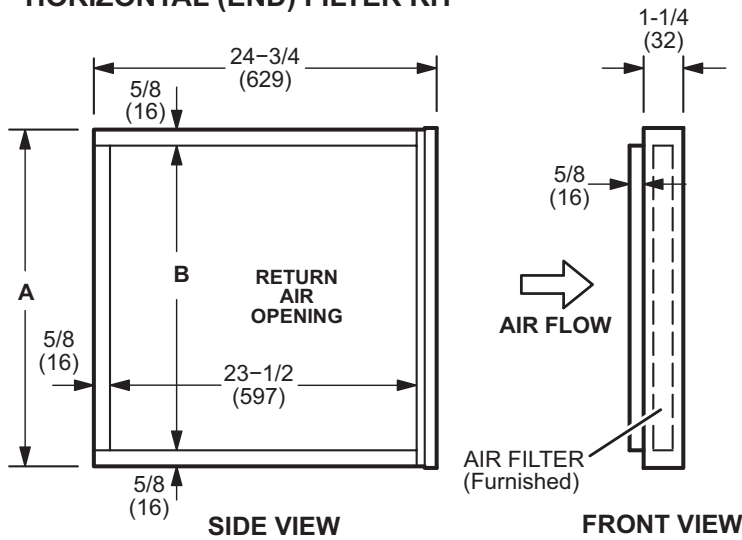

Furnace Cabinet Width	Catalog Number	A		B	
		in.	mm	in.	mm
B	87L96	18	457	16-3/4	425
C	87L97	21	533	18-3/4	476
D	87L98	25	635	23-3/4	603

OPTIONAL RETURN AIR BASE
(Upflow Applications Only - For use with B, C and D cabinets)

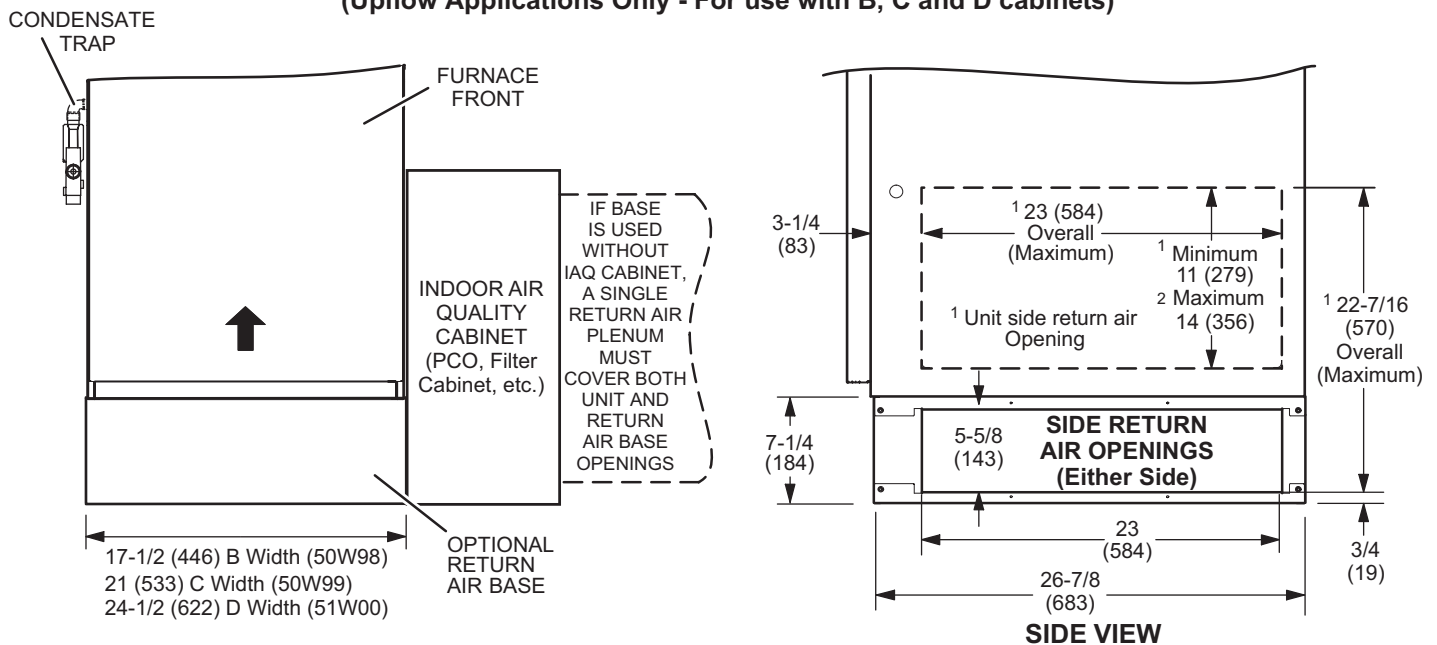

NOTE- Optional Side Return Air Filter Kits are not for use with Optional Return Air Base.

¹ Both the unit return air opening and the base return air opening must be covered by a single plenum or IAQ cabinet. Minimum unit side return air opening dimensions for units requiring 1800 cfm or more of air (W x H): 23 x 11 in. (584 x 279 mm). The opening can be cut as needed to accommodate plenum or IAQ cabinet while maintaining dimensions shown. Side return air openings must be cut in the field. There are cutting guides stenciled on the cabinet for the side return air opening. The size of the opening must not extend beyond the markings on the furnace cabinet.

² To minimize pressure drop, the largest opening height possible, up to 14 in. (356 mm), is preferred.

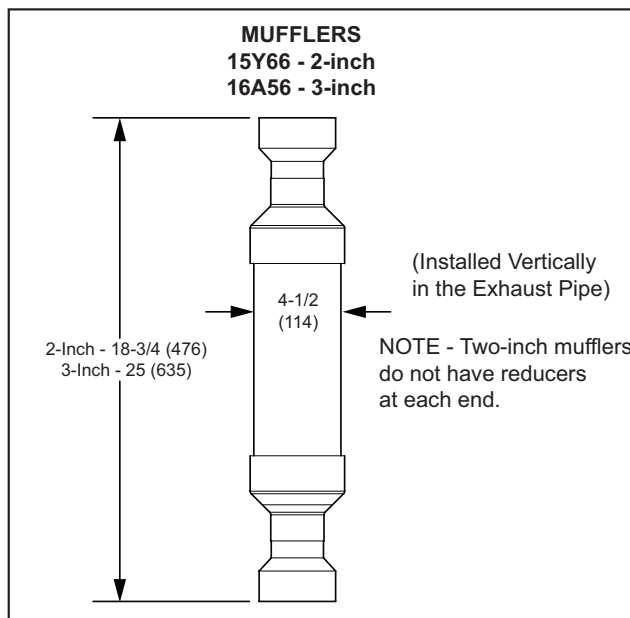
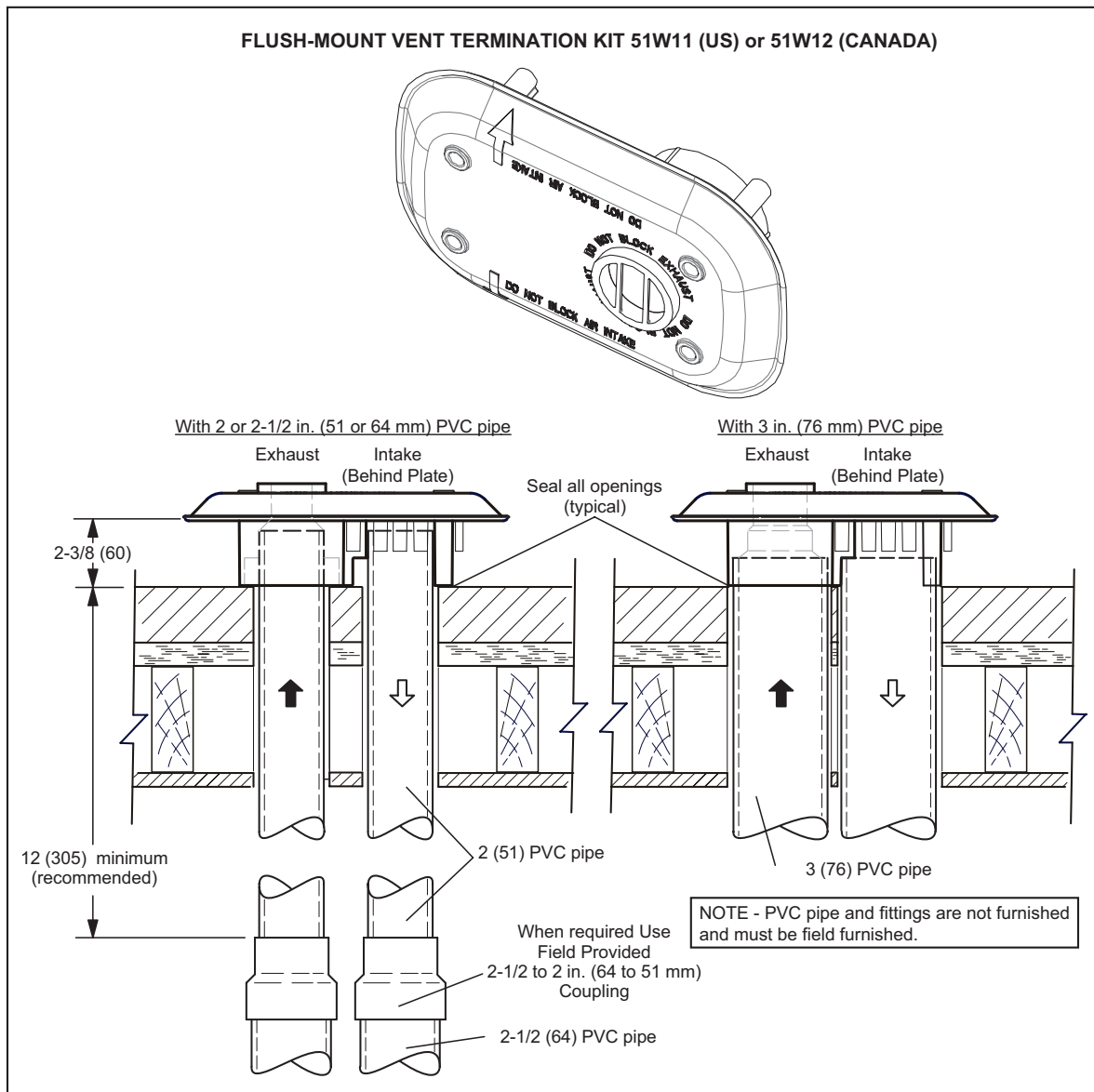

**CONCENTRIC WALL
TERMINATION APPLICATIONS**

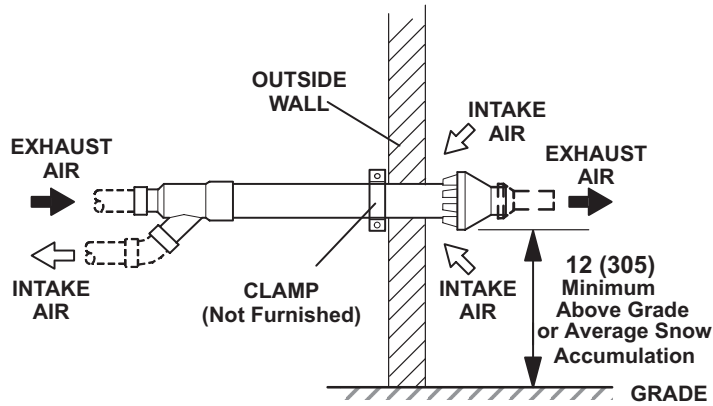

**CONCENTRIC ROOF
TERMINATION APPLICATIONS**

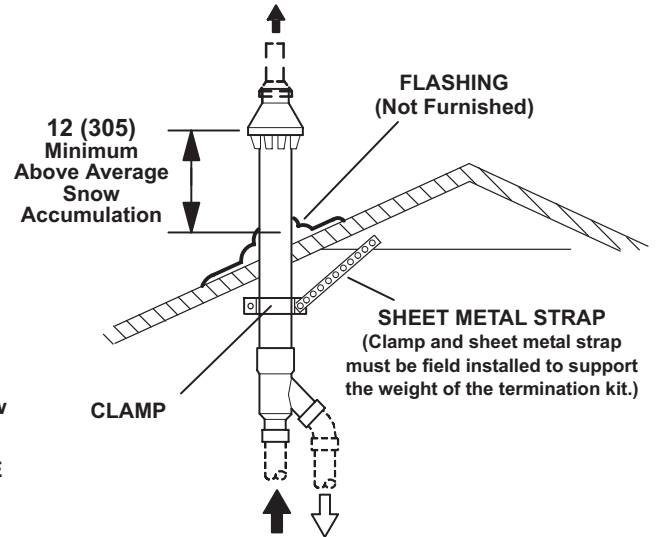

**71M80 / 69M29 / 44W92 – 2 inch kits
60L46 / 44W93 – 3 inch kits**
See Installation Instructions for additional information.

Note - Field provided reducer may be required to adapt different vent pipe sizes to termination.

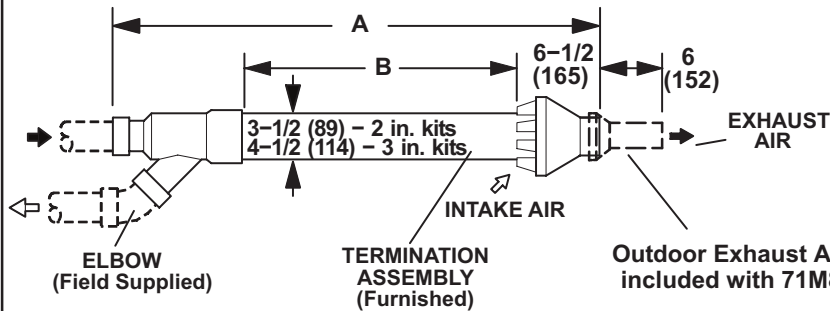

Cat. No.	A		B	
	in.	mm	in.	mm
71M80 69M29	33-3/8	848	16-3/4	425
44W92 (Canada)	29	737	15-1/2	394
60L46	38-7/8	987	21-3/16	538
44W93 (Canada)	36-1/8	918	19-1/2	495

NOTE - Typical illustration for dimensions only. Design may vary depending on kit ordered.

**WALL TERMINATION KITS (CLOSE-COUPLE)
EXTENDED VENT FOR GRADE CLEARANCE
2 inch (51 mm) 22G44 (US)
3 inch (76 mm) 44J40 (US)**

See Installation Instructions for additional information.

Note - Field provided reducer may be required to adapt different vent pipe sizes to termination.

If Intake and Exhaust Pipe is less than 12 in. (305 mm) above snow accumulation or other obstructions, field fabricated piping must be installed.

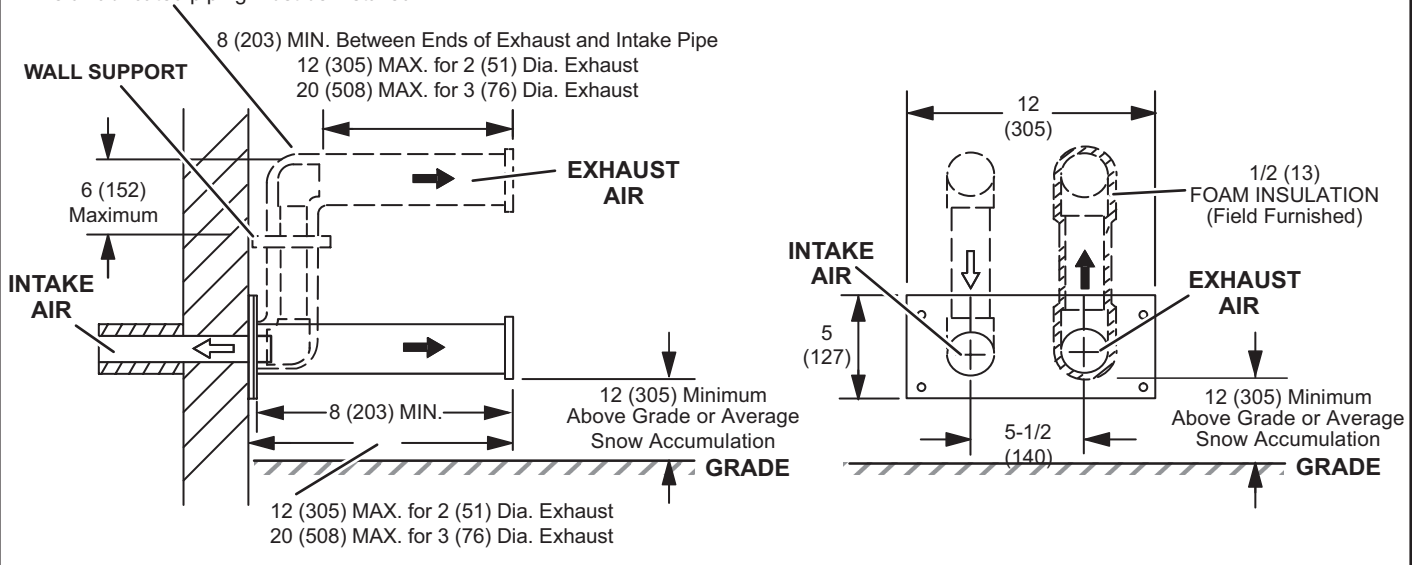

**WALL TERMINATION KITS (CLOSE-COUPLE)
EXTENDED VENT FOR GRADE CLEARANCE
2 inch (51 mm) 30G28 (WTK Canada)
3 inch (76 mm) 81J20 (WTK Canada)**

See Installation Instructions for additional information.

Note - Field provided reducer may be required to adapt different vent pipe sizes to termination.

If Intake and Exhaust Pipe is less than 12 in. (305 mm) above snow accumulation or other obstructions, field fabricated piping must be installed.

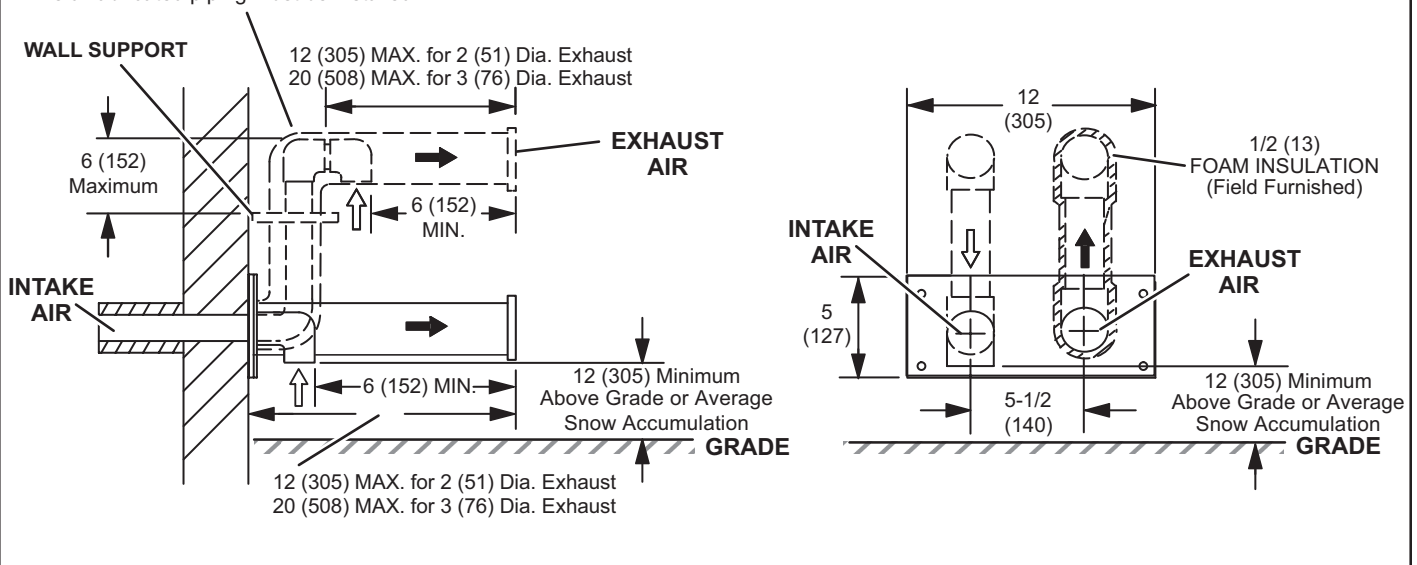

UPFLOW POSITION

Model No	C35/CX35 Cased				C35 Uncased			
	A		B		A		B	
C35/CX35	in.	mm	in.	mm	in.	mm	in.	mm
C35/CX35-18/24A C35/CX35-18/24B	16-1/2	419	49-1/2	1257	14-1/8	359	47-1/8	1197
C35/CX35-24A C35/CX35-24B	18-1/2	470	51-1/2	1308	16-3/8	416	49-3/8	1254
C35/CX35-30A C35/CX35-30B	22-1/2	572	55-1/2	1410	20-3/4	527	53-3/4	1365
C35/CX35-30/36A C35/CX35-30/36B C35/CX35-30/36C	24-1/2	622	57-1/2	1461	22-1/4	565	55-1/4	1403
C35/CX35-36A C35/CX35-36B	24-1/2	622	57-1/2	1461	22-3/8	568	55-3/8	1407
C35/CX35-48B C35/CX35-48C	27-1/2	699	60-1/2	1537	26-1/4	667	59-1/4	1505
C35/CX35-49C	29-1/2	749	62-1/2	1588	28-1/2	724	61-1/2	1562
C35/CX35-50/60C	27-1/2	699	60-1/2	1537	25-7/8	657	58-7/8	1495
CX35-60C	31-1/2	800	64-1/2	1638	30-5/8	778	63-5/8	1616
CX35-60D	29-1/2	749	62-1/2	1588	28	711	61	1549

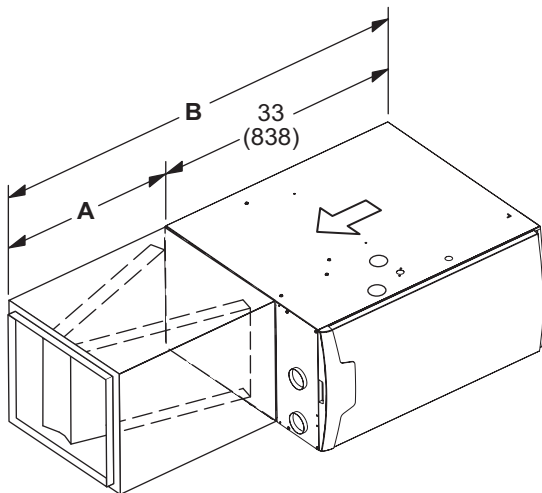
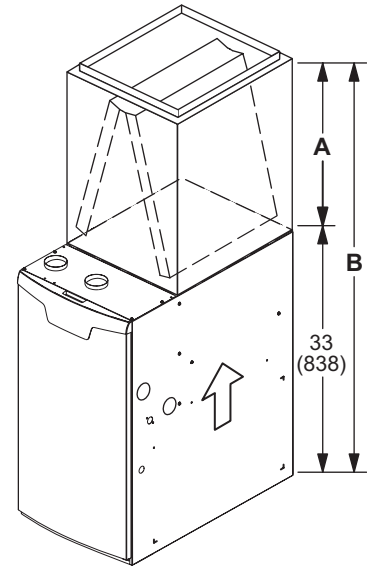

HORIZONTAL POSITION

Model No.		A		B	
		in.	mm	in.	mm
CH35					
CH35-18A, CH35-24A, CH35-24B, CH35-30B,	CH35-36A, CH35-36B, CH35-36C, CH35-42C, CH35-48C	26-1/2	673	59-1/2	1511
CH35-30A, CH35-42B, CH35-48B,	CH35-51C	31-1/2	880	64-1/2	1638
CHX35					
CHX35-18A, CHX35-24A, CHX35-24B, CHX35-30B,	CHX35-36A, CHX35-36B, CHX35-36C, CHX35-42C, CHX35-48C	26-1/2	673	59-1/2	1511
CHX35-30A, CHX35-42B, CHX35-48B,	CHX35-51/61C, CHX35-60D	31-1/2	880	64-1/2	1638

BLOWER DATA

EL296UH045XE36B PERFORMANCE (Less Filter)

External Static Pressure in. w.g.	Air Volume / Watts at Various Blower Speeds									
	High (Black)		Medium-High (Brown)		Medium (Blue)		Medium-Low (Yellow)		Low (Red)	
	cfm	Watts	cfm	Watts	cfm	Watts	cfm	Watts	cfm	Watts
0.00	1345	340	1255	245	1150	185	895	105	845	95
0.10	1305	345	1225	250	1105	200	855	110	810	95
0.20	1290	360	1190	260	1080	205	825	120	780	105
0.30	1275	370	1150	270	1045	215	785	125	720	110
0.40	1220	385	1120	280	1015	220	735	135	690	120
0.50	1215	390	1090	290	980	230	705	140	635	125
0.60	1190	395	1060	300	950	240	650	150	600	135
0.70	N/A	N/A	1015	300	900	250	620	155	555	140
0.80	N/A	N/A	1000	310	870	260	580	160	520	145

EL296UH070XE36B PERFORMANCE (Less Filter)

External Static Pressure in. w.g.	Air Volume / Watts at Various Blower Speeds									
	High (Black)		Medium-High (Brown)		Medium (Blue)		Medium-Low (Yellow)		Low (Red)	
	cfm	Watts	cfm	Watts	cfm	Watts	cfm	Watts	cfm	Watts
0.00	1380	315	1305	250	1190	200	965	105	920	100
0.10	1360	325	1270	255	1180	205	915	115	865	100
0.20	1310	335	1250	265	1130	215	880	120	815	110
0.30	1275	340	1205	275	1100	225	835	125	775	115
0.40	1250	355	1175	280	1065	230	795	135	730	125
0.50	1215	370	1145	295	1045	240	745	145	670	130
0.60	1200	380	1100	310	995	245	705	150	640	140
0.70	1145	380	1070	310	960	255	670	160	585	145
0.80	N/A	N/A	1035	320	925	265	610	165	550	155

EL296UH090XE48C PERFORMANCE (Less Filter)

External Static Pressure in. w.g.	Air Volume / Watts at Various Blower Speeds									
	High (Black)		Medium-High (Brown)		Medium (Blue)		Medium-Low (Yellow)		Low (Red)	
	cfm	Watts	cfm	Watts	cfm	Watts	cfm	Watts	cfm	Watts
0.00	1740	370	1505	250	1370	195	1285	160	1135	125
0.10	1695	390	1470	265	1325	205	1240	170	1090	135
0.20	1660	405	1435	280	1290	220	1195	185	1045	145
0.30	1615	415	1390	295	1240	235	1140	200	995	160
0.40	1590	425	1350	305	1200	245	1110	210	945	165
0.50	1560	440	1310	320	1155	260	1055	225	895	175
0.60	1525	455	1255	335	1105	270	1005	230	855	190
0.70	1475	470	1220	340	1065	285	960	245	805	200
0.80	N/A	N/A	1170	355	1010	295	920	255	760	210

BLOWER DATA

EL296UH110XE60C PERFORMANCE (Less Filter)

External Static Pressure in. w.g.	Air Volume / Watts at Different Blower Speeds																			
	Bottom Return Air, Side Return Air with Return Air from Both Sides or Return Air from Bottom and One Side.										Single Side Return Air - Air volumes in bold (over 1800 cfm) require Optional Return Air Base and field fabricated transition to accommodate 20 x 25 x 1 in. air filter in order to maintain proper air velocity.									
	High (Black)		Medium-High (Brown)		Medium (Blue)		Medium-Low (Yellow)		Low (Red)		High (Black)		Medium-High (Brown)		Medium (Blue)		Medium-Low (Yellow)		Low (Red)	
	cfm	Watts	cfm	Watts	cfm	Watts	cfm	Watts	cfm	Watts	cfm	Watts	cfm	Watts	cfm	Watts	cfm	Watts	cfm	Watts
0.00	2220	645	1940	435	1765	335	1635	280	1435	200	2185	655	1915	440	1745	340	1620	275	1430	195
0.10	2170	660	1920	460	1715	350	1595	290	1380	205	2160	660	1880	460	1705	345	1570	285	1380	205
0.20	2130	680	1865	475	1670	370	1560	305	1345	220	2115	680	1835	470	1670	365	1535	305	1325	220
0.30	2095	700	1835	490	1640	390	1525	325	1285	230	2060	705	1795	495	1630	380	1505	320	1285	230
0.40	2065	720	1785	510	1600	405	1465	335	1250	245	2050	720	1760	510	1570	400	1455	330	1235	245
0.50	2030	740	1755	525	1560	415	1425	355	1215	260	2000	740	1720	530	1535	415	1410	345	1195	260
0.60	1995	760	1705	550	1525	435	1380	370	1150	270	1955	760	1685	550	1505	435	1380	365	1145	275
0.70	1955	770	1660	560	1475	450	1350	375	1100	290	1935	775	1650	555	1455	450	1325	375	1100	285
0.80	1930	790	1635	575	1445	460	1300	395	1050	305	1890	790	1610	575	1425	460	1285	390	1055	295

EL296UH135XE60D PERFORMANCE (Less Filter)

External Static Pressure in. w.g.	Air Volume / Watts at Different Blower Speeds																			
	Bottom Return Air, Side Return Air with Return Air from Both Sides or Return Air from Bottom and One Side.										Single Side Return Air - Air volumes in bold (over 1800 cfm) require Optional Return Air Base and field fabricated transition to accommodate 20 x 25 x 1 in. air filter in order to maintain proper air velocity.									
	High (Black)		Medium-High (Brown)		Medium (Blue)		Medium-Low (Yellow)		Low (Red)		High (Black)		Medium-High (Brown)		Medium (Blue)		Medium-Low (Yellow)		Low (Red)	
	cfm	Watts	cfm	Watts	cfm	Watts	cfm	Watts	cfm	Watts	cfm	Watts	cfm	Watts	cfm	Watts	cfm	Watts	cfm	Watts
0.00	2405	940	2235	735	2070	545	1830	390	1620	280	2395	925	2235	710	2020	550	1800	380	1610	275
0.10	2365	960	2210	745	2020	565	1770	400	1585	295	2360	935	2175	735	2005	555	1760	395	1550	295
0.20	2330	975	2180	770	1950	580	1745	420	1535	315	2350	955	2160	760	1955	565	1725	415	1510	300
0.30	2295	1000	2120	785	1925	595	1690	435	1480	325	2290	990	2095	775	1890	590	1700	435	1420	325
0.40	2275	1015	2075	805	1885	615	1640	460	1445	340	2255	995	2060	795	1850	615	1635	445	1390	340
0.50	2225	1025	2035	815	1845	630	1605	475	1395	360	2230	1010	2040	815	1845	625	1590	470	1375	360
0.60	2185	1010	2020	835	1815	645	1565	485	1330	365	2170	1025	2000	820	1795	640	1580	485	1335	370
0.70	N/A	N/A	1940	850	1735	665	1520	500	1310	385	N/A	N/A	1935	845	1725	660	1520	500	1295	385
0.80	N/A	N/A	1890	860	1715	680	1465	510	1285	400	N/A	N/A	1880	855	1705	680	1470	510	1260	405

REVISIONS

Sections	Description of Change
Optional Accessories	Removed Wall Ring Kit (discontinued).



Visit us at www.lennox.com

For the latest technical information, www.LennoxPros.com

Contact us at 1-800-4-LENNOX

NOTE - Due to Lennox' ongoing commitment to quality, Specifications, Ratings and Dimensions subject to change without notice and without incurring liability. Improper installation, adjustment, alteration, service or maintenance can cause property damage or personal injury. Installation and service must be performed by a qualified installer and servicing agency.

©2021 Lennox Industries, Inc.