



HRV / ERV

HEALTHY CLIMATE®

Heat / Energy Recovery Ventilator - 60 Hz

Bulletin No. 210883

February 2021

Supersedes November 2020

RESIDENTIAL PRODUCT SPECIFICATIONS

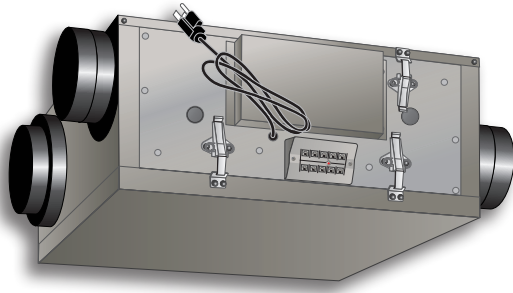

ERV5-130



HRV6-HEX095-TPD, HRV3-150-TPD,
HRV5-200-TPD, HRV5-270-TPD-ECM,
ERV5-150-TPD, ERV5-175-TPD



HRV5-150

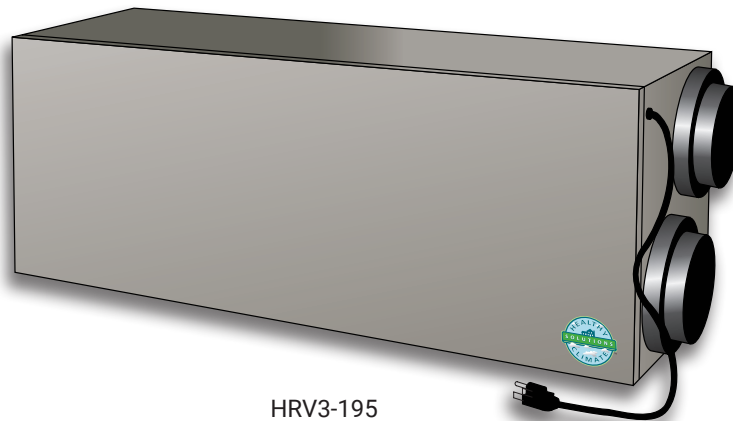

HRV3-195

MODEL NUMBER IDENTIFICATION

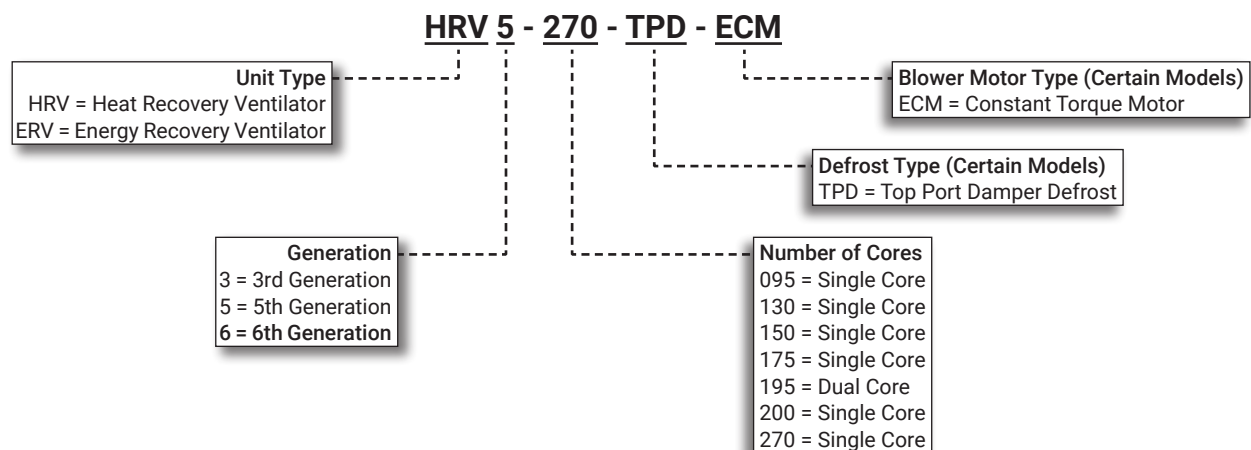

CONTENTS

Application Map	8
Approvals And Warranty	2
Blower Data	17
Dimensions - Accessories	21
Dimensions - Unit	18
Electrical Data	12
Features	3
Model Number Identification.	2
Optional Accessories	15
Specifications	12
System Sizing	9

APPROVALS AND WARRANTY

APPROVALS

- CSA certified to UL 1812 and CSA 22.2
- Certified by the Home Ventilating Institute (HVI)
- Conform to the Canadian Home Builders' Association R-2000 Standard and meet Heating, Refrigeration and Air Conditioning Institute of Canada (HRAI) standards
- Conform to CAN/ULC-S110-M1986 for non combustible material and CAN/ULC-S102-M88 for flame spread rating and smoke developed classification
- Certain models have earned the ENERGY STAR® by meeting strict energy efficiency guidelines set by Natural Resources Canada and the US EPA

NOTE - See Specifications table for certified models.

- ISO 9001 Registered Manufacturing Quality System

WARRANTY

- HRV Aluminum Core:
 - Limited lifetime warranty in residential applications
 - Limited one-year in non-residential applications
- ERV Enthalpic Core:
 - Limited ten year warranty in residential applications
 - Limited one-year in non-residential applications
- All other covered components:
 - Limited five year warranty in residential applications
 - Limited one-year in non-residential applications

NOTE - Refer to Lennox Equipment Limited Warranty certificate included with unit for specific details.

FEATURES

INSTALLATION GUIDELINES

- Lennox recommends that the HRV/ERV unit be installed in a conditioned space
- If the unit is installed above a ceiling, a separate, secondary drain pan should also be installed under the unit
- If the unit is installed in an unconditioned area condensate lines must be protected against freezing temperatures

ENERGY STAR Certified Units

- To ensure quiet operation of the ENERGY STAR certified HRV/ERV, each product model must be installed using sound attenuation techniques appropriate for the installation
- The way the heat/energy-recovery ventilator is installed can make a significant difference to the electrical energy usage
- To minimize the electricity use of the heat/energy-recovery ventilator, a stand-alone fully ducted installation is recommended
- If a simplified installation is used that operates the furnace air handler for room-to-room ventilation, an electrically efficient furnace that has an electronically commutated (EC) variable speed blower motor will minimize electrical energy consumption and operating cost
- Installation of a user-accessible control with the product model will improve comfort and may significantly reduce the product model's energy use

APPLICATIONS

- Units are completely wired and include filters
- See System Sizing section on page 10 to determine the right model for the desired application
- If use of HRV/ERV with a dehumidifier and HEPA/Carbon Filtration for optimal Indoor Air Quality (IAQ) is desired, see Lennox Service & Application Notes "HEPA Filtration with Outdoor Air and a Dehumidifier"

HRV

- Heat Recovery Ventilators (HRV) provide fresh, clean outdoor air with an energy saving temperature recovery of up to 90%
- HRV's are recommended in regions where normal humidity levels occur

NOTE - See Application Map on page 9

- Intake and exhaust air passes through a patented thermally conductive aluminum core where heat is transferred from exhaust air to incoming air

NOTE - HRV6-HEX095-TPD, HRV3-150-TPD, HRV5-150, HRV5-200-TPD and HRV5-270-TPD-ECM are top port models with four oval collars. See dimension drawings for additional information.

ERV

- Energy Recovery Ventilations (ERV) exchange energy (temperature and humidity) from stale indoor air and transfer it to incoming outdoor fresh air
- During warm seasons the unit pre-cools and dehumidifies incoming fresh air
- During cool seasons the unit pre-heats and humidifies incoming fresh air
- Intake and exhaust air passes through an enthalpic core where heat and moisture are transferred from stale exhaust air to incoming fresh air

HRV / ERV

- Centrifugal blowers bring in fresh outdoor air while at the same time exhausting an equal amount of stale indoor air
- A duct system distributes the fresh air and collects the stale air for removal from the building
- Unit airflow must be balanced for maximum efficiency

NOTE - Refer to Installation Instructions for unit air flow balancing details.

CORE ASSEMBLY

HRV Patented Aluminum Core

- Aluminum plates have excellent heat transfer characteristics, are washable, corrosion resistant and durable
- Opposed dimples pressed into each plate ensure proper separation within each core
- Modular design ensures ease of service

ERV Enthalpic Core

- Enthalpic core has excellent latent and sensible heat transfer characteristics, are vacuum cleanable, corrosion resistant and durable
- UL recognized component
- Modular design ensures ease of service

BLOWER

- Dual centrifugal style blowers with single dual shaft motor (HRV3-195, HRV5-150)
- Two backward curved centrifugal impellers with integral motors (HRV6-HEX095-TPD, HRV3-150-TPD, HRV5-200-TPD, HRV5-270-TPD-ECM, ERV5-150-TPD, ERV5-175-TPD)
- Two forward curved centrifugal impellers with integral motors (ERV5-130)
- Design allows easy access for servicing

Blower Motor

(All models except HRV5-270-TPD-ECM)

- Multi-speed direct drive PSC motor (up to 5 speed settings with optional control)

Electronically Commuted (EC) Motors (HRV5-270-TPD-ECM Only)

- Each airstream has an independent motorized electronically commuted (EC) motor with impeller for multiple fan speed operations. High cfm with minimum Watts/cfm

FEATURES

DEFROST

- The ERV/HRV has an electronically controlled defrost mechanism
- The defrost cycle is activated when the outdoor temperature drops below 27°F
- Defrost run times vary based on incoming fresh air temperature
- Three recirculating defrost modes are available:
 1. At 27°F HRV runs in defrost for 3 minutes and runs in ventilation for 25 minutes
 2. At -4°F HRV runs in defrost for 4.5 minutes and runs in ventilation for 17 minutes
 3. At -31°F HRV runs in defrost for 7 minutes and runs in ventilation for 15 minutes
- No remote device can override this defrost mode or selected speed until the cycle is complete
- After the defrost cycle is complete the unit defaults to previous settings
- If the cycle is complete and the thermistor continues to measure defrost temperature the defrost cycle is repeated

Recirculating Damper Defrost

(HRV3-150-TPD, HRV5-150, HRV5-200-TPD, HRV6-HEX095-TPD, HRV5-270-TPD-ECM, ERV5-150-TPD, ERV5-175-TPD, ERV5-130)

- During defrost a motor driven damper door mechanism closes off the supply air from outside allowing exhaust air to recirculate through the unit's core
- During defrost cycle no ventilation is occurring
- After the defrost period, the damper operates in the opposite direction to reopen the fresh air port
- Defrost cycle repeats until the temperature rises above 27°F

Damper Defrost

(HRV3-195 Models)

- During defrost a motor driven damper door mechanism closes off the supply air from outside allowing the fifth port to open, enabling warm room air to be drawn in from around the unit
- During defrost cycle stale air exhaust is still occurring
- After the defrost period, the damper operates in the opposite direction to reopen the fresh air port
- Defrost cycle repeats until the temperature rises above 27°F
- The defrost port can also be ducted to another location

CABINET

- Constructed of 20 gauge pre-painted quartz gray steel
- Interior is lined with foil-faced polystyrene to eliminate noise, condensation and air loss
- Cabinet is designed for structural strength and long life
- Access panels are hinged, have quick release latches and can be completely removed for easy access to filters and core(s) for servicing
- Safety interlock switch automatically shuts off power to unit when access panel is opened
- Four polyester hanging straps provided with unit (ERV5-130 has 4 mounting brackets included)
- Condensate drain pans have drain connection (except ERV5-130)

System Balancing

- HRV6-HEX095-TPD, HRV5-270-TPD-ECM, HRV3-150-TPD, HRV5-150, HRV5-200-TPD, ERV5-150-TPD and ERV5-175-TPD models include a patented, balancing damper located in the intake and exhaust air stream collar
- HRV3-150-TPD, HRV5-150, HRV5-200-TPD, HRV5-HEX095-TPD, HRV5-270-TPD-ECM, ERV5-150-TPD and ERV5-175-TPD models include door port balancing capability. See installation instructions
- HRV3-195 and ERV5-130 models requires an optional field installed butterfly damper for system balancing
- See Optional Accessories

OPTIONAL ACCESSORIES (MUST BE ORDERED SEPARATELY)

AIR FILTER

- MERV 6 air filters are furnished in both exhaust and intake air streams
- Polyester filters are easily removed for cleaning
- Design and location of filters allows maximum filtration with minimum air resistance

NOTE - See Optional Accessories for MERV 13 filters.

ELECTRICAL

Control Box

- Contains control circuit board and auto-transformer

Plug-in Electrical Connection

- Convenient 36 inch (approx. length) power cord with 3-prong 120VAC plug provided for easy electrical connection

CONTROLS

Circuit Board

- Circuit board controls unit operation
- Dip Switches enable and disable defrost and recirculation and selection of maximum speed
- Up to five blower speeds and five modes of operation are available with optional wall mount controls

Self-Test

- When unit is energized, the HRV/ERV cycles through all speeds available, tests damper motor operation, and returns to the previous operational mode and speed selection

Dehumidistat Disable Feature

- The dehumidistat function will be disabled if the outdoor temperature exceeds 59°F for a 24-hour period
- The dehumidistat function will be re-enabled if the unit is unplugged or if the outdoor temperature drops below 59°F for a 24-hour period

Furnace/Air Handler Interlock Capability

- Built-in function on HRV/ERV allows unit to turn on/off furnace or air handler blower
- Refer to Installation Instructions for interlocking unit to furnace or air handler

NOTE - If connecting to an iComfort® S30 or E30 thermostat refer to the thermostat installation instructions for interlocking.

Terminal Block

- Control Board is wired to external terminal block located on side of unit
- Terminal block allows connection to various wall mount controls
- See Optional Accessories for complete listing
- Terminal block also allows interlock control connection to furnace or air handler



Thermostats and Controls (not furnished)

- Thermostats and controls are not furnished and must be ordered extra
- See Optional Accessories tables

OPTIONAL ACCESSORIES (MUST BE ORDERED SEPARATELY)

ICOMFORT® THERMOSTATS

NOTE - iComfort® S30 and E30 Smart Thermostats can control HRV and ERV units without the need for a separate controller. The iComfort® S30 Ultra-Smart Thermostat and iComfort® E30 Smart Thermostat requires firmware version 3.5 or higher and Smart Hub 2.0.

- Units can be setup based on house size and be configured for timed only or ASHRAE 62.2 ventilation modes on the touchscreen

iComfort® S30 Ultra-Smart Wi-Fi Thermostat (part of the iComfort® Residential Communicating Control System)

- Recognizes and connects to all iComfort® Communicating products to automatically configure and control the heating/cooling system (based on user-specified settings) for the highest level of comfort, performance and efficiency
- Recognizes model and serial number information for iComfort® Communicating products to simplify system setup
- Wi-Fi remote temperature monitoring and adjustment through a home wireless network for desktop PCs, laptops and apps for smartphones or tablets
- Service alerts and reminders sent via text message or e-mail
- Smart home automation compatible with Apple HomeKit™, Amazon Alexa®, Google Assistant and IFTTT
- Service Dashboard features online real-time monitoring of installed iComfort® thermostats
- Simple easy-to-use touchscreen allows complete system configuration
- Scheduled maintenance alerts, system warnings and troubleshooting are also displayed on thermostat screen
- Easy to read 7 inch high definition color display (measured diagonally)
- Conventional outdoor units (not iComfort® Communicating) can easily be added and controlled by the iComfort® S30 Thermostat
- Installer setup screens allow quick and simple system configuration without a manual, Installer can also run tests on complete system or individual components for easy maintenance and troubleshooting
- Serial communications bus (RSBus), with less wiring than a conventional heating/cooling system, allows system communication
- Uses 4-wire, standard thermostat wiring
- High Definition Color Display, Mag-Mount, Smart Hub Controller, wallplate (for retrofit installations) furnished for easy installation
- See the iComfort® S30 Thermostat Product Specifications bulletin for more information



iComfort® E30 Smart Wi-Fi Thermostat

- Wi-Fi enabled, electronic 7-day, universal, multi-stage, programmable, touchscreen thermostat
- 3 Heat/2 Cool
- Auto-changeover
- Controls dehumidification during cooling mode and humidification during heating mode
- Offers enhanced capabilities including humidification / dehumidification / dewpoint measurement and control, Humiditol® control, and equipment maintenance reminders
- Easy to read 7 in. color touchscreen (measured diagonally)
- LCD display with backlight shows the current and set temperature, time, inside relative humidity, system status (operating mode and schedules) and outside temperature (optional outdoor sensor required)
- Smooth Setback Recovery starts system early to achieve setpoint at start of program period
- Compressor short-cycle protection (5 minutes)
- Up to four separate schedules are available plus Schedule IQ™
- One-Touch Away Mode - A quick and easy way to set the cooling and heating setpoints while away
- Smart Away™ - Uses geo-fencing technology to determine when the homeowner is within a predetermined distance from the home to operate the system when leaving, away and arriving
- Wi-Fi remote monitoring and adjustment through a home wireless network for desktop PCs, laptops and apps for smartphones or tablets
- Smart home automation compatible with Apple HomeKit™, Amazon Alexa®, Google Assistant and IFTTT
- Service Dashboard features online real-time monitoring of installed iComfort® thermostats
- High Definition Color Display, Mag-Mount, Smart Hub Controller, wallplate (for retrofit installations) furnished for easy installation
- See the iComfort® E30 Smart Wi-Fi Thermostat Product Specifications bulletin for more information



Remote Outdoor Temperature Sensor

- Used with the iComfort® Communicating thermostats and the iComfort® E30 Smart Thermostat
- When installed outdoors, sensor allows thermostat to display outdoor temperature

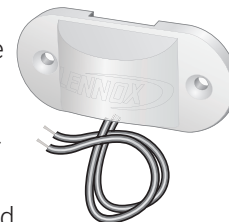

NOTE - Sensor is required for Enhanced Dehumidification Control (EDA) applications.

NOTE - The outdoor sensor is furnished as standard with iComfort® Communicating outdoor units, optional for conventional units.

OPTIONAL ACCESSORIES (MUST BE ORDERED SEPARATELY)

CONTROLS (continued)

Healthy Climate® Basic Wall Mount 2 Speed Dehumidistat/Ventilation Control

- ON/OFF button with indicator LED
- Dehumidistat with graduated LED indicators (20 to 60% relative humidity)

NOTE - Dehumidistat is off when no LEDs are lit.

- Fan Speed button for High, Low and Standby
- Compatible with Wireless 20 / 40 / 60 Minute Timer
- 3-wire, 20-gauge (min.), low-voltage wire connection
- Designed to be mounted in a standard 2 x 4 in. electrical box or surface mounted to a wall



Healthy Climate® Digital 5 Speed / 5 Mode Dehumidistat/Ventilation Control

Fully digital control determines when and how much fresh air will enter the home.

- 5-speed blower setting
- Standby setting (blower speed 0)
- Electronic dehumidistat
- Five selectable modes of operation:
 1. Continuous Ventilation
 2. ¹ 20 min. Ventilation / 40 min. Recirculation
 3. 20 min. Ventilation / 40 min. Off
 4. 10 min. Ventilation / 50 min. Off
 5. ¹ Continuous Recirculation
- 20 / 40 / 60 high speed override button
- Compatible with Wireless/Wired 20 / 40 / 60 Minute Timer
- Instruction card inserted in control
- Easy-to-read backlit LCD screen
- Service Indicator
- 3-wire, 20-gauge (min.), low-voltage wire connection
- Slim-line design



¹ **NOTE** - Recirculation mode not available on all models.

Healthy Climate® Wired 20 / 40 / 60 Minute Timer

Remotely located timer allows 20, 40 or 60 minute operation.

- One-touch button activates high speed
- 3 indicator LED's show timer status
- Lockout feature eliminates tampering
- 3-wire, 20-gauge (min.), low-voltage wire connection
- Installs in a standard 2 x 4 in. electrical box



Healthy Climate® Wireless 20 / 40 / 60 Minute Timer

Remotely located timer allows 20, 40 or 60 minute wireless operation when paired with the Wall Mount Dehumidistat/Ventilation Control or the Digital 5 Speed / 5 Mode Control.

- 40 ft. range
- One-touch button activates high speed
- 3 indicator LED's show timer status
- No wiring, timer is paired with the main control
- Multiple timers can be paired to a single main control
- Designed to be mounted in a standard 2 x 4 in. electrical box or surface mounted to a wall
- Battery (CR2450) lithium button type is furnished.



Healthy Climate® Wireless Repeater

The Wireless Repeater is used to extend range of the Wireless Timer.

- Installed halfway in-between the Wireless Timer and the main control if the timer is out of range
- Plugs directly into a 120V power outlet
- LED indicates connection status:
 - Green = Connected to the wall control
 - Flashing = Moderate connection to the wall control
 - Red = No connection to the wall control
- Multiple Repeaters can be paired to a single main control



INDOOR AIR QUALITY

MERV 13 High Efficiency Filters

- MERV 13 (Minimum Efficiency Reporting Value based on ASHRAE 52.2)
- Includes four filters
- Installed on the fresh air intake

NOTE - Recommended replacement every 3 months.

OPTIONAL ACCESSORIES (MUST BE ORDERED SEPARATELY)

AIR BALANCING TOOLS

Optional Accessories

Butterfly Balancing Damper

- 6 or 7 in. diameter



Backdraft Damper

- 5 or 6 in. diameter
- Spring-loaded damper is installed on the Stale Air to Outside ducting
- See System Applications

Door Port Gauge Tube Set (HRV3-150-TPD/TPF, HRV5-150, HRV5-200-TPD, HRV5-HEX095-TPD, HRV5-270-TPD-ECM, ERV5-150-TPD & ERV5-175-TPD Models Only)

- Includes two connection hoses and two rubber fittings and instructions



NOTE - Magnehelic gauge or digital manometer (reading down to 0 with resolution of 0.001 in. w.g.) is not furnished and must be field supplied.

DUCTWORK

Optional Accessories

Duct Heaters

- Duct heaters are available to temper incoming fresh air after heat recovery
- Heaters have built-in electronic modulating controller and air flow/temperature sensor to proportionally adjust the heating load to match the exact capacity required while minimizing operating costs
- Available in 6 inch (1 or 2 kW) and 7 inch (2 kW) diameter sizes
- Voltage/Phase - 120/1
- H x W x L - 8-1/2 x 11-1/2 x 12-1/2 in.



Flexible Ducts - Insulated or Non-Insulated

- Non-insulated ducts are available for connection to optional circular grilles
- Constructed of aluminum foil/polyester laminate and metalized polyester film around a steel wire helix
- Fully insulated fiberglass ducts have an "R" value of 4.2 and are available for connection to outside weatherhoods (refer to local codes)



Hinged Kitchen Exhaust Grille

- Louvered panel is hinged for easy access to washable aluminum grease filter
- Size - 6 x 10 in. in white



Round Diffusers

- White molded plastic grilles are available for room air distribution
- Grilles are adjustable for room to room system balancing
- Compression spring tab clips into round duct
- Available in 4, 5, 6 and 8 inch diameters



Weatherhood Kit

- Two furnished per kit, one for intake air and one for exhaust air
- Labeled for easy identification
- Fully adjustable for different wall thickness
- Complete with 1/4 in. mesh bird screen, two 12 in. sleeves with insulating duct collars
- Hinged hood allows easy cleaning of screen
- White finish. Available in 5, 6, and 7 inch diameters







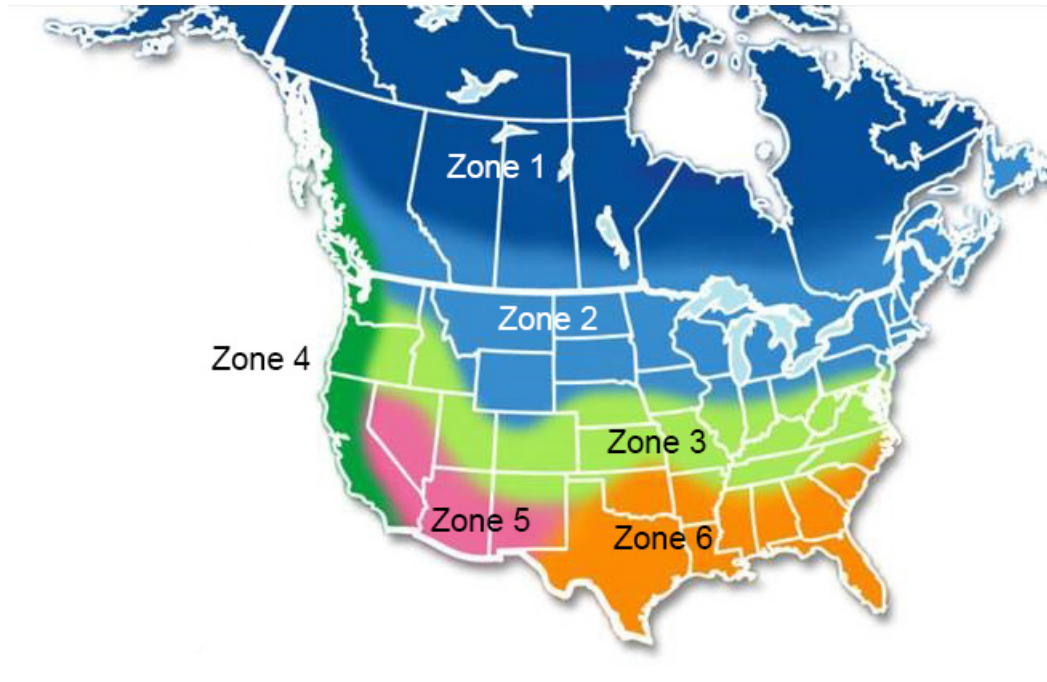

Dual Hood

- Dual Hood only requires a single 6 inch diameter penetration in the exterior wall for the fresh air intake and stale air exhaust connections
- Stale air is exhausted from the front of the hood while fresh air intake is from the bottom of the hood
- Compatible with 5 in. or 6 in. duct
- See dimension drawing on page 22
- See pressure drop charts on page 17

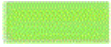

APPLICATION MAP



	ZONE 1	True North - Cold Winter and Dry Summer - HRV	HRV is best for a very cold and prolonged winter.
	ZONE 2	US - Canada Border - Cold Winter and Hot Humid Summer - HRV or ERV	HRV is best for a cold or prolonged winter. ERV will help reduce the AC load in the summer by transferring moisture.
	ZONE 3	Central US - Moderate Climate - HRV or ERV	HRV and ERV will work equally well. ERV will help reduce the AC load in the summer by transferring moisture.
	ZONE 4	Marine Climate - HRV or ERV	Humidity and temperature are moderated by HRV or ERV.
	ZONE 5	Arid Climate - Hot and Dry - HRV	HRV will transfer energy summer and winter. With little moisture to transfer an ERV is not needed.
	ZONE 6	Gulf Region - Hot and Humid Climate - ERV	ERV is recommended. Primary benefit is transferring energy and moisture throughout summer and winter.

NOTE - All HRV and ERV models have an integrated defrost system for cold climates.

ERV is recommended in regions where high outdoor humidity causes air conditioning operation for dehumidification more frequently than heating system operation.

SYSTEM SIZING

SIZING A CENTRAL VENTILATION SYSTEM

- The HRV and ERV is part of a central ventilation system
- The system can include multiple fans such as kitchen range hoods and bathroom exhaust fans in addition to the HRV or ERV
- An HRV can be used in place of a bathroom exhaust fan and provide supplemental ventilation in the kitchen (it cannot be used as a range hood)
- Therefore determining the required Ventilation cfm will depend on the application and standard/method used for calculation

Method #1

Size the HRV/ERV to provide 1/3 air change per hour - International Residential Code (IRC) 2006

- This method requires determining the volume of the home and then providing enough air flow to have one complete air change every 3 hours
- Example: A home has 2000 square feet of conditioned floor space and 8 ft. ceilings
- The volume is $2000 \times 8 = 16,000$ cubic feet. To obtain required airflow in cfm, multiply by 1/3 and divide by 60 minutes/hour: Required airflow, cfm = $16,000 \text{ cu. ft.} \times 1/3 \text{ ACH} / 60 \text{ minutes/hr} = 88 \text{ cfm}$

Method #2

Use a Room Count to find the required airflow - CSA-F326

- Determine the number of bedrooms and add 1. Multiply this by 10 cfm. An additional 10 cfm is required for every other room in the house. An unfinished basement requires 20 cfm
- Example: A home with 4 bedrooms, 2 bathrooms, living room, kitchen, dining room and basement requires 120 cfm

Method #3

ASHRAE (American Society of Heating Refrigeration and Air Conditioning Engineers) Standard 62.2-2016

- This standard describes the minimum ventilation required based on the ASHRAE 4.1a Quick Reference Chart
- Example a 2000 square foot home with 4 bedrooms from ASHRAE 4.1 a quick reference chart predicts 98 cfm

Method #4

Home Ventilating Institute (HVI):

- HVI recommends using the minimum ventilation rate as specified by ASHRAE 62.2 and adding 2 cfm/100 sq. ft. of floor area
- Example a 2000 square foot home with 4 bedrooms from ASHRAE 4.1a Quick Reference Chart predicts 98 cfm + 40 cfm = 138 cfm

WHOLE BUILDING VENTILATION AIR REQUIREMENTS
ASHRAE 4.1a (I-P) Quick Reference Chart

Floor Area sq. ft.	No. of Bedrooms				
	1	2	3	4	5
	cfm	cfm	cfm	cfm	cfm
<500	30	38	45	53	60
501 - 1000	45	53	60	68	75
1001 - 1500	60	68	75	83	90
1501 - 2000	75	83	90	98	105
2001- 2500	90	98	105	113	120
2501 - 3000	105	113	120	128	135
3001 - 3500	120	128	135	143	150
3501 - 4000	135	143	150	158	165
4001 - 4500	150	158	165	173	180
4501 - 5000	165	173	180	188	195

SYSTEM SIZING

Method #5

Custom method to achieve a target VOC's level in homes

- Ventilation or source control may be required above the ASHRAE rates if there are significant sources; or to achieve specific concentration level(s) of chemical(s) of interest [for instance achieving $<20 \text{ } \mu\text{g}/\text{m}^3$ of formaldehyde (HCHO) as recommended by the CDC/HUD and NIOSH for occupied trailers]
- If ventilation rates other than mentioned above are desired, dealers may wish to obtain the services of a certified IAQ consultant to obtain guidance and laboratory measurements of chemical(s) of concern both before and after installation and operation of additional ventilation to insure that the target concentration(s) of chemical(s) of concern are achieved
- Dealers and homeowner need to be aware that reaching specific concentration target(s) may be an iterative process
- For instance if there are multiple furnace/air handlers in the home, ventilation may be added to one or more of the indoor units to start with, and if the desired level(s) of chemical(s) of concern are not obtained, additional ventilation can be added to the additional indoor units or more rigorous source control measures implemented (i.e. removing contaminant sources from the home)
- One option is to size the HRV/ERV based on low speed fan operation or 20 minute/hour operation to one of the above methods which will allow ventilation to be easily increased by changing a controller setting if desired

NOTE - Dealer should always calculate increased load requirement due to ventilation and insure that HVAC system is sized appropriately to handle both sensible (temperature) and latent (humidity) loads.

Note - In some locations, a standalone dehumidifier may be required to handle the increased latent (humidity) load to prevent increased humidity in the home.

SIZING A CENTRAL VENTILATION SYSTEM

SUMMARY OF THE ABOVE CALCULATIONS USING VARIOUS METHODS

Method 1 - Cubic Volume - 88 cfm

Method 2 - Room Count - 120 cfm

Method 3 - ASHRAE 62.2 - 98 cfm

Method 4 - HVI Recommendation - 138 cfm

Method 5 - Custom calculation. Size on one of above methods on low speed fan or 20 minute/hour operation. After measuring chemical(s) of concern, adjust operation accordingly

- All methods were calculated using the same 2,000 sq. ft. with 8 ft. ceiling house as an example
- Choose the cfm which satisfies the code requirement of your area and application
- All sizing is done based on HIGH fan speed data but normal operation is constant LOW fan speed with times of HIGH fan speed from a timer, dehumidistat or wall control
- Typically a 0.3 in. w.g. static is used for choosing the correct model (however your duct design would negate the static you want to use for the calculated cfm) for your installation design, see exact model specifications for details (HVI certified data for the unit)

NOTE - It is always recommended a proper duct design is done.

SYSTEM SIZING

SETUP WITH ICOMFORT S30 OR E30 THERMOSTAT

- Determine ventilation cfm required based on local code or one of the above methods
- Select an HRV or ERV model which can deliver approximately 25% more than the required cfm at high speed for the designed static pressure, or 0.3 in. w.g. for the default static pressure
- After installation, balance the HRV or ERV on high speed and maximum capacity, making sure that the blower system is operating
- Use Door Port Balancing method (using a manometer with an accuracy of ± 0.02 in. w.g. and a resolution of 0.001) or pitot tube to measure the cfm
- This is the cfm to set in the S30 or E30 installer HRV/ERV screen, "Ventilation Rate for High Speed"
- For low speed (speed 1), use a pitot tube to measure the cfm of fresh air and stale air. Use the higher cfm value to set in the S30 or E30 installer HRV/ERV screen, "Ventilation Rate for Low Speed"



SETUP WITH BASIC OR DELUXE CONTROL

- Determine ventilation cfm required based on local code or one of the methods above
- Select an HRV or ERV model which can deliver the required cfm at high speed for the designed static pressure, or 0.3 in. w.g. for the default static pressure
- After installation, balance the HRV or ERV on high speed to the required cfm making sure the blower system is operating

NOTE - Dealer should always calculate increased load requirement due to ventilation and insure that HVAC system is sized appropriately to handle both sensible (temperature) and latent (humidity) loads.

NOTE - In some locations, a standalone dehumidifier may be required to handle the increased latent (humidity) load to prevent increased humidity in the home.

SPECIFICATIONS - HRV

		Model No.	HRV6-HEX095-TPD	HRV5-150	HRV3-150-TPD
		No. of Cores	Single	Single	Single
¹ ENERGY STAR® Certified (Canada Only)					No
² Performance	Adjusted Sensible Recovery Efficiency @ 32°F		79% (64 cfm)	82% (64 cfm)	68% (66 cfm)
	Sensible Recovery Efficiency @ 32°F		75% (64 cfm)	75% (64 cfm)	61% (66 cfm)
	Adjusted Sensible Recovery Efficiency @ -13°F		68% (66 cfm)	76% (69 cfm)	65% (76 cfm)
	Sensible Recovery Efficiency @ -13°F		65% (66 cfm)	72% (69 cfm)	61% (76 cfm)
² Blower	Air Flow (cfm) vs. Static Pressure (high speed)	0.1 in. w.g.	110	170	170
		0.2 in. w.g.	104	159	155
		0.3 in. w.g.	97	148	148
		0.4 in. w.g.	89	140	136
		0.5 in. w.g.	81	125	125
		0.6 in. w.g.	72	---	114
		0.7 in. w.g.	61	---	102
		0.8 in. w.g.	49	---	89
		0.9 in. w.g.	---	---	76
		1.0 in. w.g.	---	---	57
Number of Speeds Available (with S30/E30 or Basic Control)			2	2	2
Number of Speeds Available (with Digital Control)			5	5	5
Defrost type			Recirculating	Recirculating	Recirculating
Door Port Balancing			Yes	Yes	Yes
Balancing Damper in Intake and Exhaust Collar			Yes	Yes	Yes
Duct Ports	Connections (No.) & diameter - inch		(2) 5 outside (oval) (2) 5 inside (oval)	(2) 6 outside (round) (2) 6 inside (round)	(2) 5 outside (oval) (2) 5 inside (oval)
Condensate drain (o.d.) - in. (includes tee)			(2) 1/2	(2) 1/2	(2) 1/2
Shipping weight - lbs.			63	71	49
ELECTRICAL DATA					
Voltage			120 volts - 60 Hertz - 1 phase		
Blower HP (PSC type)			1/10	1/10	1/20
³ Fan Watts - high speed @HVI Test SRE maximum rated cfm			43	119	140
³ Fan Watts - low speed @HVI Test SRE minimum rated cfm			34	71	74
Amp Rating			0.5	1.4	1.2



NOTE - Effectiveness is based on temperature difference between the two air streams. Efficiency includes parasitic losses from fan operation.

¹ This product earned the ENERGY STAR® by meeting strict energy efficiency guidelines set by Natural Resources Canada and the US EPA. This product meets ENERGY STAR requirements only when used in Canada.

² Certified by the Home Ventilating Institute (HVI) according to test procedures developed by HVI members and based on internationally recognized standards. For performance ratings at other conditions not shown, please visit the [HVI website](#).

³ Sensible Recovery Efficiency (SRE) tested at 32°F.

SPECIFICATIONS - HRV

		Model No.	HRV5-200-TPD	HRV3-195	HRV5-270-TPD-ECM
		No. of Cores	Single	Dual	Single
¹ ENERGY STAR® Certified (Canada Only)					
² Performance	Adjusted Sensible Recovery Efficiency @ 32°F		82% (64 cfm)	87% (64 cfm)	77% (64 cfm)
	Sensible Recovery Efficiency @ 32°F		76% (64 cfm)	81% (64 cfm)	75% (64 cfm)
	Adjusted Sensible Recovery Efficiency @ -13°F		73% (102 cfm)	70% (114 cfm)	71% (70 cfm)
	Sensible Recovery Efficiency @ -13°F		70% (102 cfm)	68% (114 cfm)	70% (70 cfm)
² Blower	Air Flow (cfm) vs. Static Pressure (high speed)	0.1 in. w.g.	203	222	280
		0.2 in. w.g.	193	210	273
		0.3 in. w.g.	182	195	267
		0.4 in. w.g.	172	176	261
		0.5 in. w.g.	159	157	254
		0.6 in. w.g.	148	133	248
		0.7 in. w.g.	136	108	242
		0.8 in. w.g.	121	83	235
		0.9 in. w.g.	108	57	227
		1.0 in. w.g.	93	- - -	220
Number of Speeds Available (with S30/E30 or Basic Control)			2	2	2
Number of Speeds Available (with Digital Control)			5	5	5
Defrost type			Recirculating	Damper	Recirculating
Door Port Balancing			Yes	No	Yes
Balancing Damper in Intake and Exhaust Collar			Yes	No	Yes
Duct Ports	Connections (No.) & diameter - inch		(2) 6 outside (oval) (2) 6 inside (oval)	(2) 6 outside (round) (2) 7 inside (round) (1) 6 defrost (round)	(2) 6 outside (oval) (2) 6 inside (oval)
Condensate drain (o.d.) - in. (includes tee)			(2) 1/2	(2) 1/2	(2) 1/2
Shipping weight - lbs.			67	96	68
ELECTRICAL DATA					
		Voltage	120 volts - 60 Hertz - 1 phase		
		Blower HP (PSC type)	1/10	1/10	1/10 (ECM)
³ Fan Watts - high speed @HVI Test SRE maximum rated cfm			92	93	44
³ Fan Watts - low speed @HVI Test SRE minimum rated cfm			60	66	22
Amp Rating			1.4	1.5	2.1

NOTE - Effectiveness is based on temperature difference between the two air streams. Efficiency includes parasitic losses from fan operation.

¹ This product earned the ENERGY STAR® by meeting strict energy efficiency guidelines set by Natural Resources Canada and the US EPA. This product meets ENERGY STAR requirements only when used in Canada.

² Certified by the Home Ventilating Institute (HVI) according to test procedures developed by HVI members and based on internationally recognized standards. For performance ratings at other conditions not shown, please visit the [HVI website](http://www.hvi.com).

³ Sensible Recovery Efficiency (SRE) tested at 32°F.

SPECIFICATIONS - ERV

		Model No.	ERV5-130	ERV5-150-TPD	ERV5-175-TPD
		No. of Cores	Single	Single	Single
¹ ENERGY STAR® Certified (Canada Only)			No		No
² Performance	Adjusted Sensible Recovery Efficiency @ 32°F		77% (64 cfm)	82% (64 cfm)	85% (66 cfm)
	Sensible Recovery Efficiency @ 32°F		72% (64 cfm)	75% (64 cfm)	75% (66 cfm)
	Adjusted Sensible Recovery Efficiency @ -13°F		- - -	64% (70 cfm)	62% (68 cfm)
	Sensible Recovery Efficiency @ - 13°F		54% (53 cfm)	60% (70 cfm)	58% (68 cfm)
	Latent Efficiency @ 95 °F		38% (64 cfm)	43% (66 cfm)	41% (64 cfm)
	Total Efficiency @ 95 °F		44% (64 cfm)	48% (66 cfm)	48% (64 cfm)
	² Blower	Air Flow (cfm) vs. Static Pressure (high speed)	0.1 in. w.g.	133	161
		0.2 in. w.g.	129	155	184
		0.3 in. w.g.	125	146	172
		0.4 in. w.g.	123	138	161
		0.5 in. w.g.	119	127	150
		0.6 in. w.g.	112	117	140
		0.7 in. w.g.	108	104	129
		0.8 in. w.g.	102	93	117
		0.9 in. w.g.	95	83	106
		1.0 in. w.g.	87	74	93
Number of Speeds Available (with S30/E30 or Basic Control)			2	2	2
Number of Speeds Available (with Digital Control)			5	5	5
Defrost type			Recirculating	Recirculating	Recirculating
Door Port Balancing			No	Yes	Yes
Balancing Damper in Intake and Exhaust Collar			No	Yes	Yes
Duct Ports	Connections (No.) & diameter - inch		(2) 5 outside (round) (2) 5 inside (round)	(2) 5 outside (oval) (2) 5 inside (oval)	(2) 6 outside (oval) (2) 6 inside (oval)
Condensate drain (o.d.) - in. (includes tee)			- - -	(2) 1/2	(2) 1/2
Shipping weight - lbs.			45	46	63
ELECTRICAL DATA					
Voltage		120 volts - 60 Hertz - 1 phase			
Blower HP (PSC type)			1/10	1/20	1/20
³ Fan Watts - high speed @HVI Test SRE maximum rated cfm			86	102	96
³ Fan Watts - low speed @HVI Test SRE minimum rated cfm			48	66	62
Amp Rating			1.4	1.7	1.4

NOTE - Effectiveness is based on temperature difference between the two air streams. Efficiency includes parasitic losses from fan operation.

¹ This product earned the ENERGY STAR® by meeting strict energy efficiency guidelines set by Natural Resources Canada and the US EPA. This product meets ENERGY STAR requirements only when used in Canada.

² Certified by the Home Ventilating Institute (HVI) according to test procedures developed by HVI members and based on internationally recognized standards. For performance ratings at other conditions not shown, please visit the [HVI website](#).

³ Sensible Recovery Efficiency (SRE) tested at 32°F.

OPTIONAL ACCESSORIES - HRV - ORDER SEPARATELY

Model No.		HRV6- HEX095-TPD	HRV3-150- TPD	HRV5-150	HRV3-195	HRV5-200- TPD	HRV5-270- TPD-ECM
Air Filters - MERV 13 (4 per order)		21V13	20A91	21V13	20A91	21V13	21V13
Air Balancing Tools	Door Port Gauge Tube Set	Y2207	Y2207	Y2207	N/A	Y2207	Y2207
Backdraft Damper	5 in. diameter	Y3728	Y3728	---	---	---	---
	6 in. diameter	---	---	Y3727	Y3727	Y3727	Y3727
Butterfly Damper	6 inch diameter	Furnished	Furnished	Furnished	---	Furnished	Furnished
	7 inch diameter	---	---	---	Field Provided	---	---
iComfort® Controls	S30 Ultra-Smart Thermostat	19V30	19V30	19V30	19V30	19V30	19V30
	E30 Smart Thermostat	20A65	20A65	20A65	20A65	20A65	20A65
¹ Remote Outdoor Air Temperature Sensor		X2658	X2658	X2658	X2658	X2658	X2658
Controls	Basic 2 Speed Control	Y8249	Y8249	Y8249	Y8249	Y8249	Y8249
	Digital 5 Speed/4 Mode Control	Y8250	Y8250	Y8250	Y8250	Y8250	Y8250
	Wired 20/40/60 Minute Fan Timer	Y2169	Y2169	Y2169	Y2169	Y2169	Y2169
	² Wireless 20/40/60 Minute Fan Timer	Y8251	Y8251	Y8251	Y8251	Y8251	Y8251
	Wireless Repeater	Y8252	Y8252	Y8252	Y8252	Y8252	Y8252
² Dual Hood		Y3813	Y3813	Y3813	Y3813	Y3813	Y3813
Duct Heaters	6 in. diameter (1 kW)	97E73	97E73	97E73	97E73	97E73	97E73
	6 in. diameter (2 kW)	20N16	20N16	20N16	20N16	20N16	20N16
	7 in. diameter (2 kW)	97E74	97E74	97E74	97E74	97E74	97E74
	Voltage/Phase (60 Hz)	120/1	120/1	120/1	120/1	120/1	120/1
	Amps - 1 kW Heater	8.3	8.3	8.3	8.3	8.3	8.3
	Amps - 2 kW Heaters	16.7	16.7	16.7	16.7	16.7	16.7
	⁴ Flexible Ducts - No. & dia. - in.		(2) 6	(2) 5	(2) 6	(2) 6	(2) 6
Hinged Kitchen Exhaust Grille		18N48	18N48	18N48	18N48	18N48	18N48
Round Diffusers	4 in. diameter	92E54	92E54	92E54	92E54	92E54	92E54
	5 in. diameter	92E55	92E55	92E55	92E55	92E55	92E55
	6 in. diameter	92E56	92E56	92E56	92E56	92E56	92E56
	8 in. diameter	56N81	56N81	56N81	56N81	56N81	56N81
⁵ Weatherhood Kit (2 per kit)	5 in. diameter	92E66	92E66	92E66	92E66	92E66	92E66
	6 in. diameter	95P07	95P07	95P07	95P07	95P07	95P07
	7 in. diameter	17N11	17N11	17N11	17N11	17N11	17N11

¹ Remote Outdoor Temperature Sensor is used with conventional (non-iComfort® Communicating) outdoor units (sensor is furnished with iComfort® Communicating outdoor units). Allows the thermostat to display outdoor temperature. Required in dual-fuel and EDA applications

² Wireless Timer (Y8251) is only compatible with Basic or Digital Control. For S30 or E30 use Wired Timer (Y2169).

³ See Dual Hood Pressure Drop/Airflow Charts for applications.

⁴ Contact your Territory Manager for additional information.

⁵ Two Required, one for fresh air intake, one for stale air exhaust.

OPTIONAL ACCESSORIES - ERV - ORDER SEPARATELY

Model No.		ERV5-130	ERV5-150-TPD	ERV5-175-TPD
Air Filters - MERV 13 (4 per order)		20A90	20A91	20A91
Backdraft Damper	6 in. diameter	Y3727	Y3727	Y3727
Butterfly Damper	6 inch diameter	Furnished	Furnished	Furnished
iComfort® Controls	S30 Ultra-Smart Thermostat	19V30	19V30	19V30
	E30 Smart Thermostat	20A65	20A65	20A65
Controls	Basic 2 Speed Control	Y8249	Y8249	Y8249
	Digital 5 Speed/4 Mode Control	Y8250	Y8250	Y8250
	Wired 20/40/60 Minute Fan Timer	Y2169	Y2169	Y2169
	¹ Wireless 20/40/60 Minute Fan Timer	Y8251	Y8251	Y8251
	Wireless Repeater	Y8252	Y8252	Y8252
² Dual Hood		Y3813	Y3813	Y3813
Duct Heaters	6 in. diameter (1 kW)	97E73	97E73	97E73
	6 in. diameter (2 kW)	20N16	20N16	20N16
	7 in. diameter (2 kW)	97E74	97E74	97E74
	Voltage/Phase (60 Hz)	120/1	120/1	120/1
	Amps - 1 kW Heater	8.3	8.3	8.3
	Amps - 2 kW Heaters	16.7	16.7	16.7
³ Flexible Ducts - No. & dia. - in.		(2) 6	(2) 6	(2) 6
Hinged Kitchen Exhaust Grille		18N48	18N48	18N48
Round Diffusers	4 in. diameter	92E54	92E54	92E54
	5 in. diameter	92E55	92E55	92E55
	6 in. diameter	92E56	92E56	92E56
	8 in. diameter	56N81	56N81	56N81
³ Weatherhood Kit (2 per kit)	5 in. diameter	92E66	92E66	92E66
	6 in. diameter	95P07	95P07	95P07
	7 in. diameter	17N11	17N11	17N11

¹ Wireless Timer (Y8251) is only compatible with Basic or Digital Control. For S30 or E30 use Wired Timer (Y2169).

² See Dual Hood Pressure Drop/Airflow Charts for applications.

³ Contact your Territory Manager for additional information.

⁴ Two Required, one for fresh air intake, one for stale air exhaust.

DUAL HOOD PRESSURE DROP/AIRFLOW CHARTS

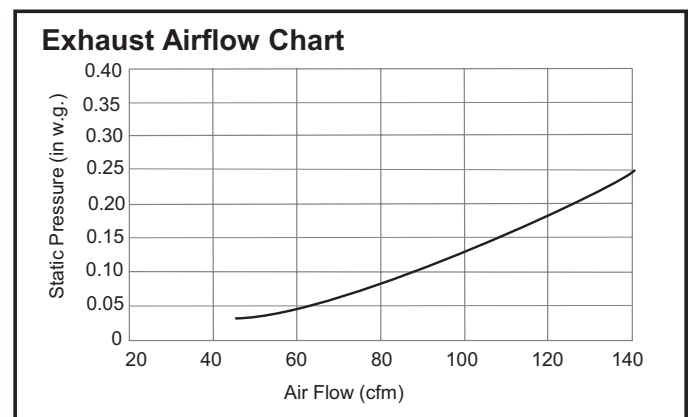
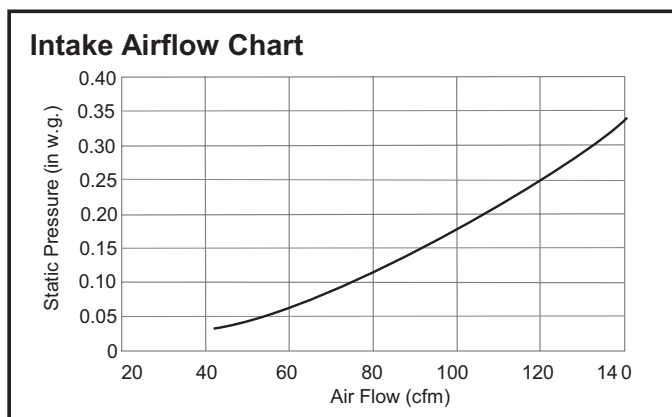

BLOWER DATA

FOR OPTIONAL CONTROLS (Factory Tested)

Model No.	HRV6-HEX095-TPD	HRV3-150-TPD	HRV5-150	HRV3-195	HRV5-200-TPD	HRV5-270-TPD-ECM	ERV5-130	ERV5-150-TPD	ERV5-175-TPD
Air Flow vs. Static Pressure									
in. w.g.	Speed 4 - Medium-High (cfm)								
0.10	98	---	153	167	189	249	117	127	n/a
0.20	95	---	141	159	170	239	112	119	138
0.30	89	---	131	150	153	228	110	112	123
0.40	80	101	117	140	136	217	105	105	112
0.50	70	91	96	124	120	204	98	96	101
0.60	60	82	80	110	106	190	95	89	88
0.70	---	69	---	93	91	176	88	80	74
0.80	---	60	---	---	78	160	80	---	62
in. w.g.	Speed 3 - Medium (cfm)								
0.10	95	---	144	142	161	209	100	100	n/a
0.20	90	---	130	136	141	198	96	98	115
0.30	80	92	120	127	123	185	92	90	101
0.40	72	82	106	118	108	171	89	82	90
0.50	60	71	88	103	92	155	84	75	75
0.60	---	60	---	92	77	137	80	64	63
0.70	---	---	---	72	64	118	75	---	50
0.80	---	---	---	---	52	97	---	---	---
in. w.g.	Speed 2 - Medium-Low (cfm)								
0.10	88	---	127	115	127	158	N/A	N/A	n/a
0.20	80	81	116	107	108	142	N/A	N/A	89
0.30	70	70	106	100	90	123	N/A	N/A	75
0.40	60	60	97	90	73	101	N/A	N/A	60
0.50	---	46	86	81	60	75	N/A	N/A	47
0.60	---	---	---	66	48	45	N/A	N/A	---
0.70	---	---	---	---	38	---	N/A	N/A	---
0.80	---	---	---	---	---	---	N/A	N/A	---
in. w.g.	Speed 1 - Low (cfm)								
0.10	70	---	108	88	100	106	63	66	n/a
0.20	58	61	100	80	78	79	60	60	61
0.30	45	49	91	73	60	45	57	54	48
0.40	36	35	78	63	46	---	53	45	35
0.50	---	---	---	56	32	---	50	37	---
0.60	---	---	---	43	---	---	44	---	---
0.70	---	---	---	---	---	---	---	---	---
0.80	---	---	---	---	---	---	---	---	---

BLOWER DATA WITH OPTIONAL DUAL HOOD

NOTE - Perform all calculations for duct sizing in the usual manner (taking into account measured and equivalent lengths).

Model No.	Airflow (cfm) at Nominal External Static Pressure - in. w.g.			Compatible with Dual Air Hood?
	0.30	0.40	0.50	
HRV6-HEX095-TPD	78	70	59	Yes
HRV3-150-TPD	115	104	95	Yes
HRV5-150	115	103	87	Yes
HRV3-195	125	114	107	Yes
HRV5-200-TPD	128	120	110	Yes
HRV5-270-TPD-ECM	N/A	N/A	N/A	No
ERV5-130	118	113	112	Yes
ERV5-150-TPD	117	104	93	Yes
ERV5-175-TPD	140	129	103	Yes

DIMENSIONS - UNIT

HRV6-HEX095-TPD HEAT RECOVERY VENTILATORS

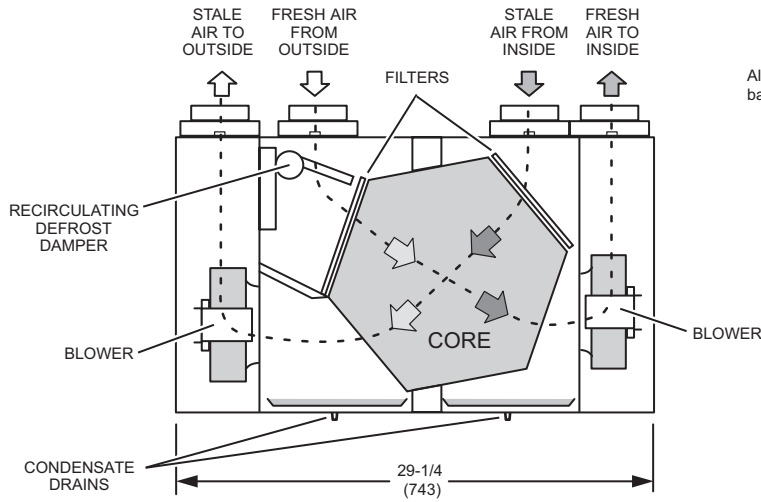

All duct connections are oval collars for use with 5 in. (127 mm) ductwork, balancing dampers are located on all collars.

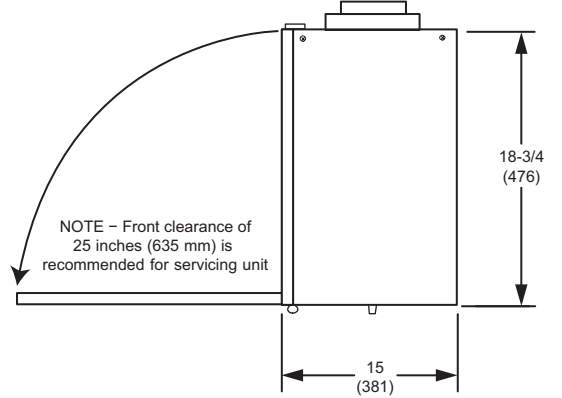

HRV3-150-TPD HEAT RECOVERY VENTILATORS

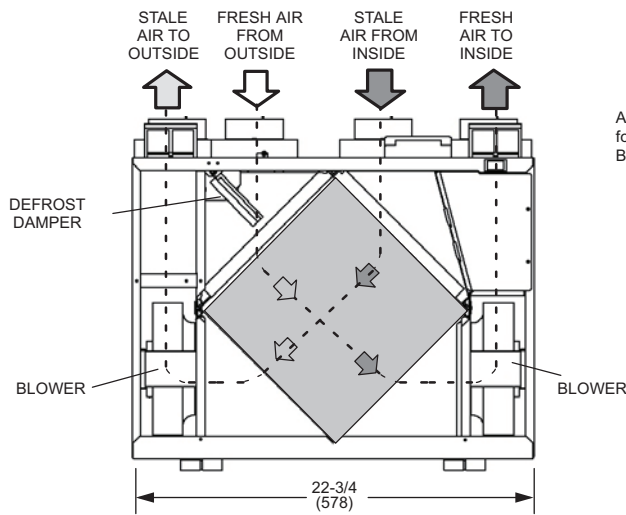

All duct connections are oval collars for use with 5 in. (125 mm) ductwork. Balancing Dampers are located on all collars.

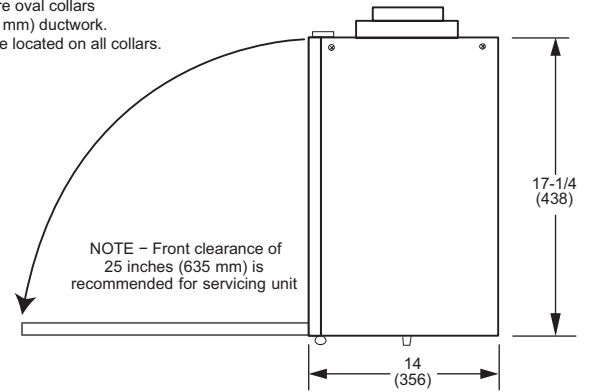

HRV5-150 HEAT RECOVERY VENTILATORS

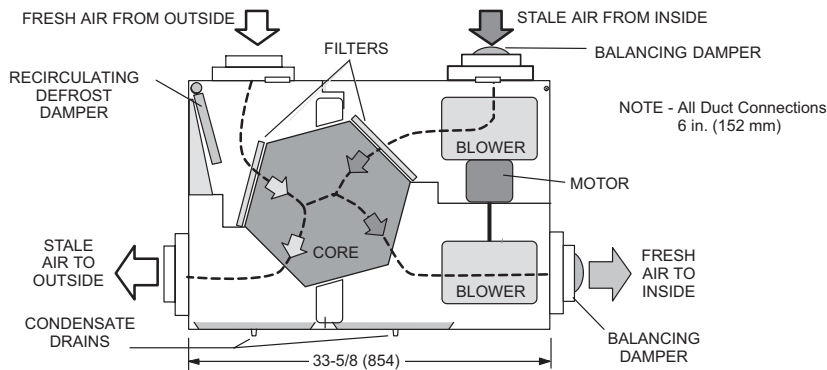

NOTE - All Duct Connections 6 in. (152 mm)

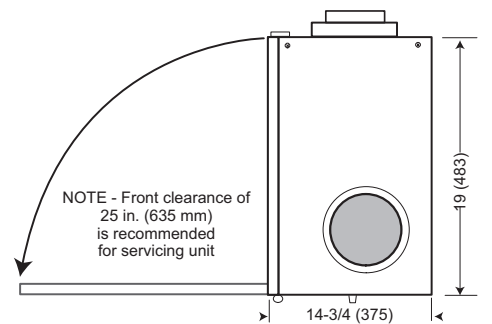

HRV3-195 HEAT RECOVERY VENTILATORS

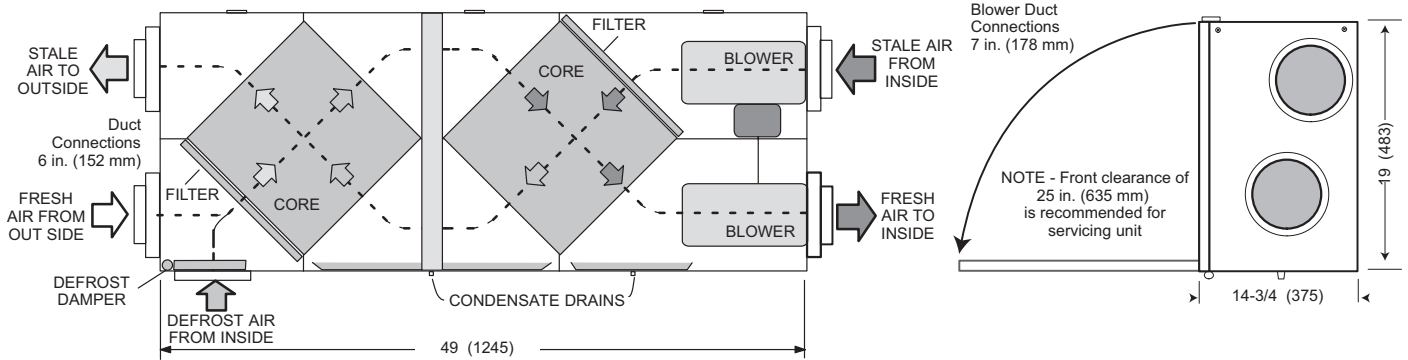

HRV5-200-TPD, HRV5-270-TPD-ECM HEAT RECOVERY VENTILATORS

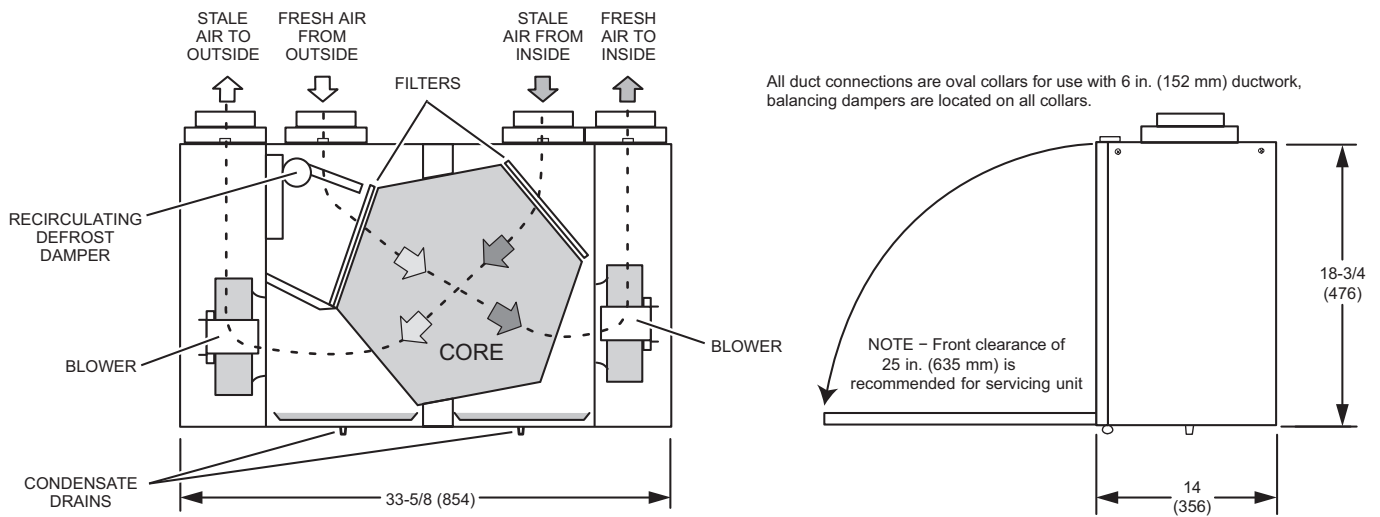

DIMENSIONS - UNIT

ERV5-130 ENERGY RECOVERY VENTILATOR

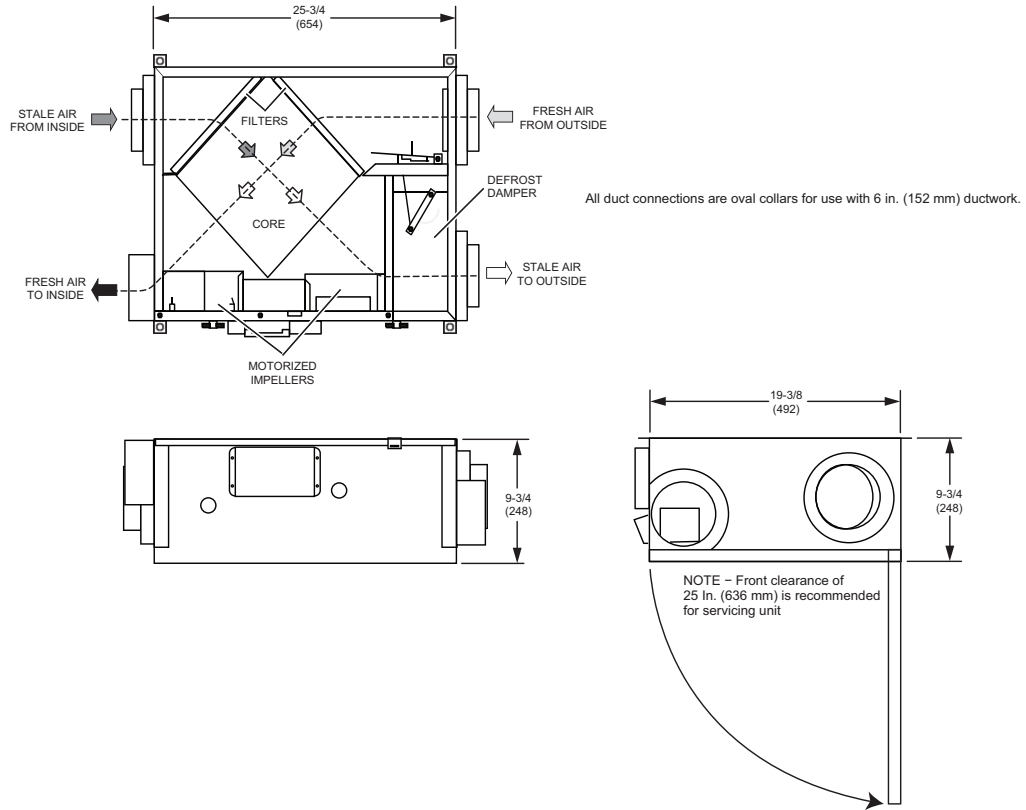

ERV5-150-TPD ENERGY RECOVERY VENTILATOR

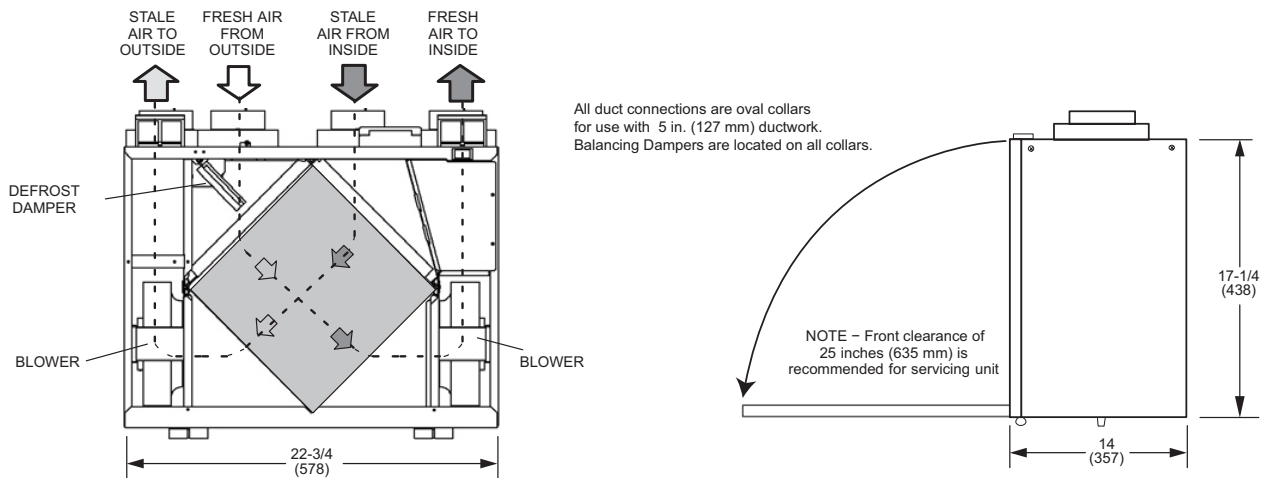

ERV5-175-TPD ENERGY RECOVERY VENTILATORS

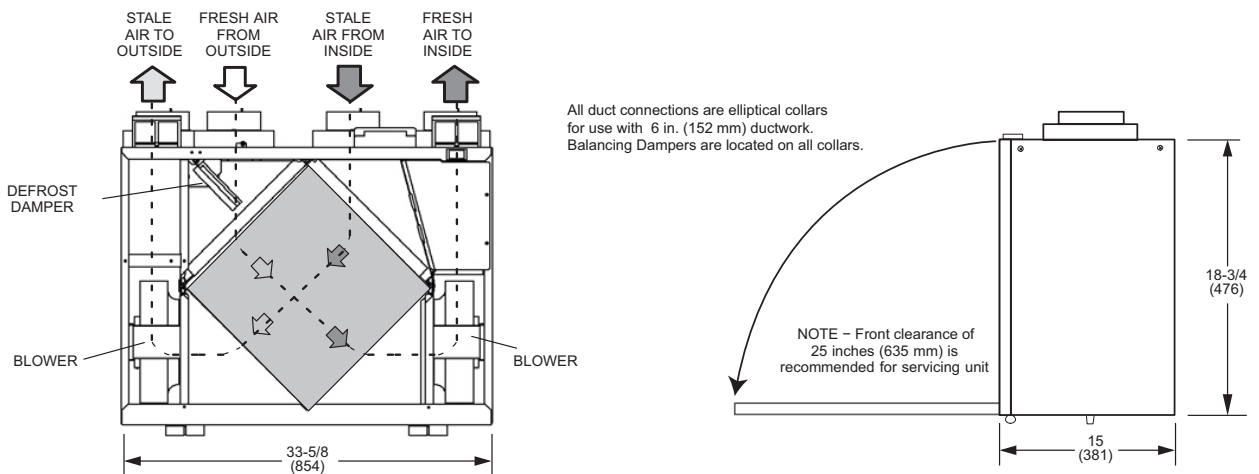

DIMENSIONS - ACCESSORIES

DUAL HOODS

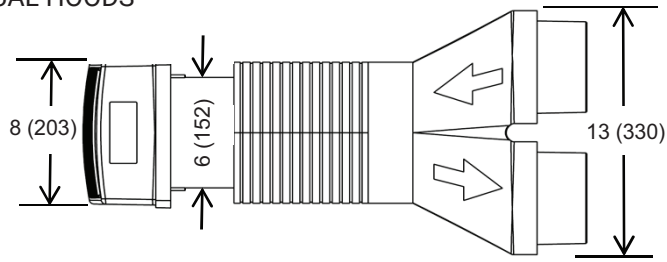

TOP VIEW

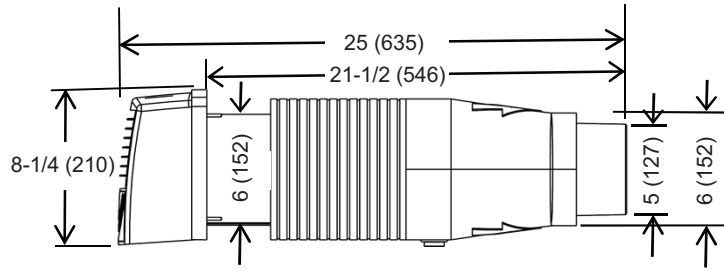

SIDE VIEW

TYPICAL SYSTEM APPLICATIONS

SIMPLIFIED INSTALLATION (Return/Return Method)

(Direct connection of both supply and exhaust air streams to the air handler cold air return)

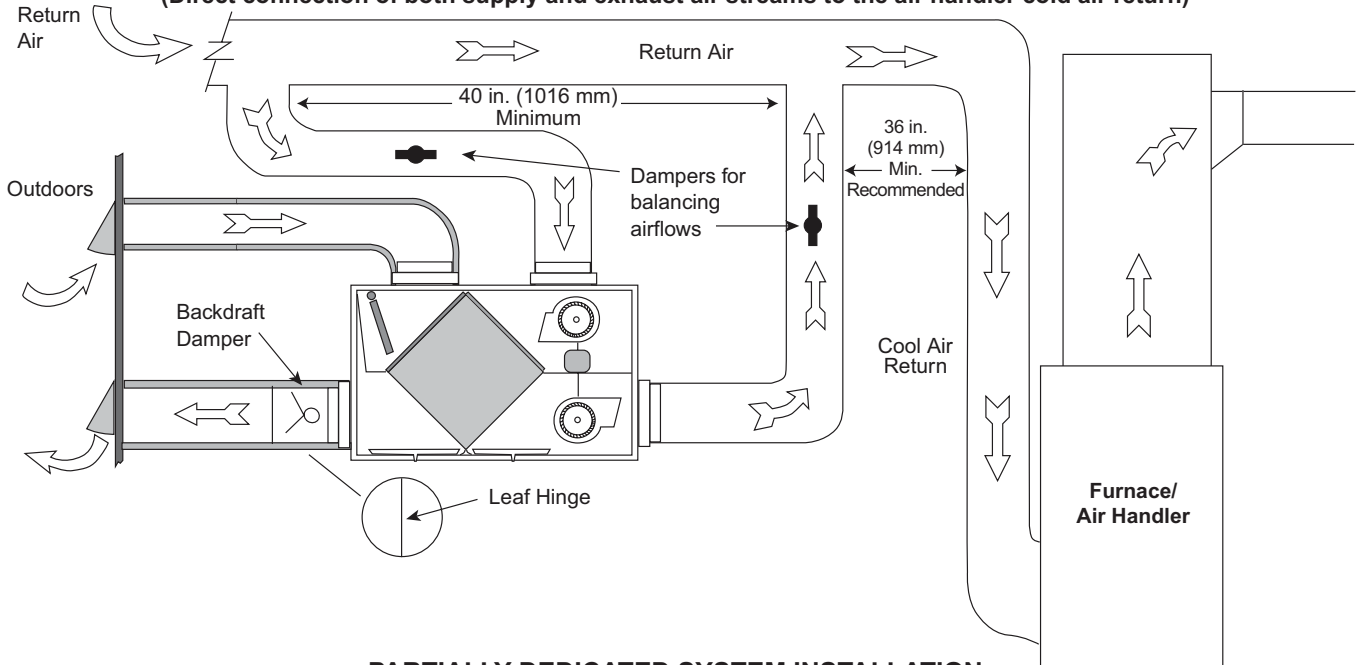

PARTIALLY DEDICATED SYSTEM INSTALLATION

(Direct connection of supply air stream to the air handler cold air return)
(Stale air drawn from key areas of home)

EXHAUST AIR from various parts of home.
(i.e. bathrooms, kitchens, utility areas)

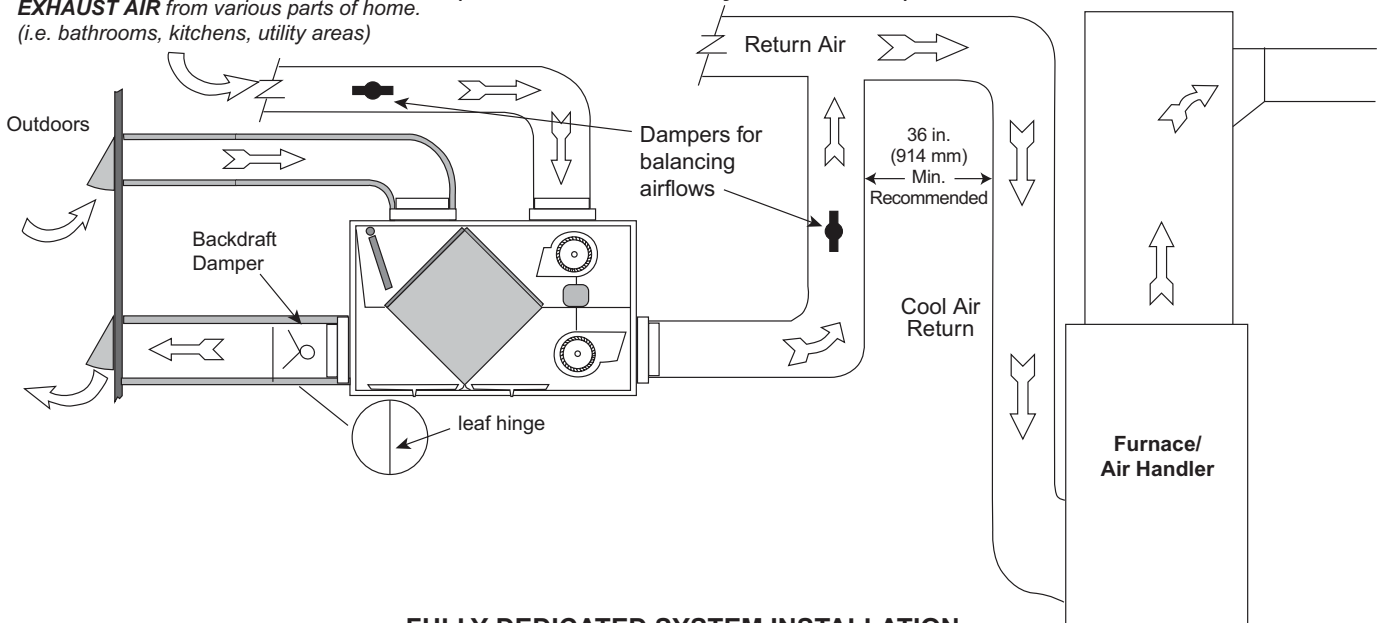

FULLY DEDICATED SYSTEM INSTALLATION

(Fresh air supplied to main living areas of house. Stale air drawn from key areas of home)

Stale air from various parts of home (i.e. bathrooms, kitchens, utility areas)

Fresh air to house - main living areas, bedrooms, living room, rec. room, etc.

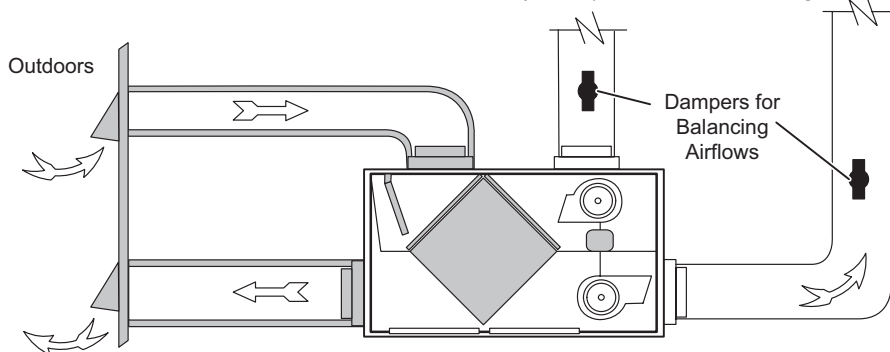

REVISIONS

Sections	Description of Change
Document	Deleted HRV3-095 and HRV5-HEX095-TPD models. Product discontinued New model added - HRV6-HEX095-TPD, specifications, ratings and dimensions.
Optional Accessories	Healthy Climate® Wired 20 / 40 / 60 Minute Timer redesigned.
Specifications	Updated for HRV5-150, HRV3-150-TPD, HRV3-195, ERV5-130.



HRAI
YOUR ENVIRONMENT • OUR EXPERTISE
✓ MEMBER COMPANY



Visit us at www.Lennox.com

For the latest technical information, www.LennoxPros.com

Contact us at 1-800-4-LENNOX

NOTE - Due to Lennox' ongoing commitment to quality, Specifications, Ratings and Dimensions subject to change without notice and without incurring liability.
Improper installation, adjustment, alteration, service or maintenance can cause property damage or personal injury.
Installation and service must be performed by a qualified installer and servicing agency.

©2021 Lennox Industries, Inc.