

EPIC™ SERIES
GCS24-953-1353-1603-3003
PACKAGED UNITS
COOLING & GAS HEAT

GCS24
(7.5, 10, 12.5 and 25 Ton)
(26.4, 35.2, 44.0 to 87.9 kW)

*88,000, 119,000, 144,000 & 289,000 Btuh (25.8, 34.9, 42.2 & 84.7 kW) Cooling Capacity
126,000 to 470,000 Btuh (36.9 to 137.7 kW) Input Heating Capacity

Bulletin No. 210028
July 1995
Supersedes June 1994
and Bulletin No. 210054
June 1994

*ARI Standard Ratings

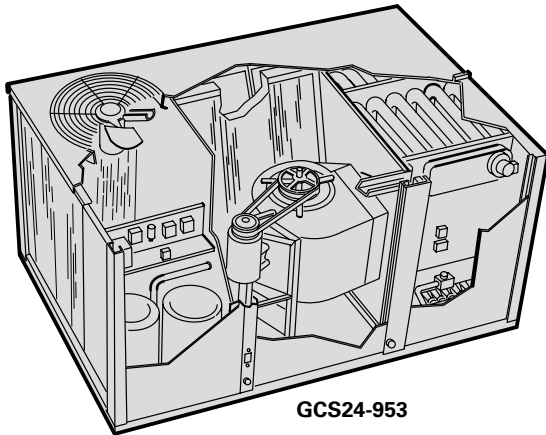

GCS24-953

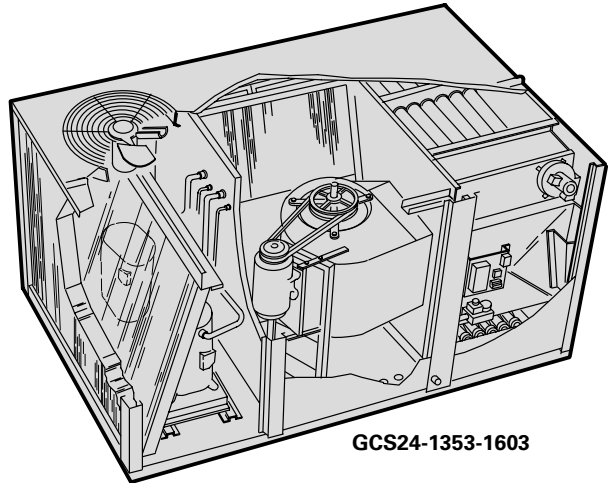

GCS24-1353-1603

Typical Applications

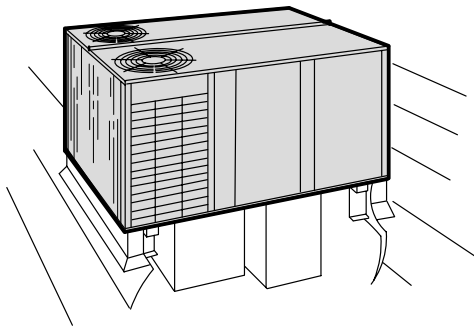

Down-Flo Supply and Return Air Installation
With RMF16 Roof Mounting Frame.

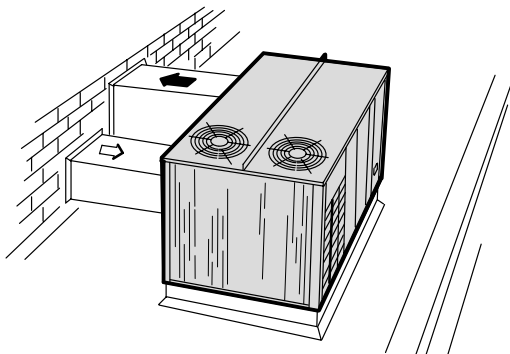

Horizontal (Side) Supply and Return Air Installation
With RMF16 Roof Mounting Frame.

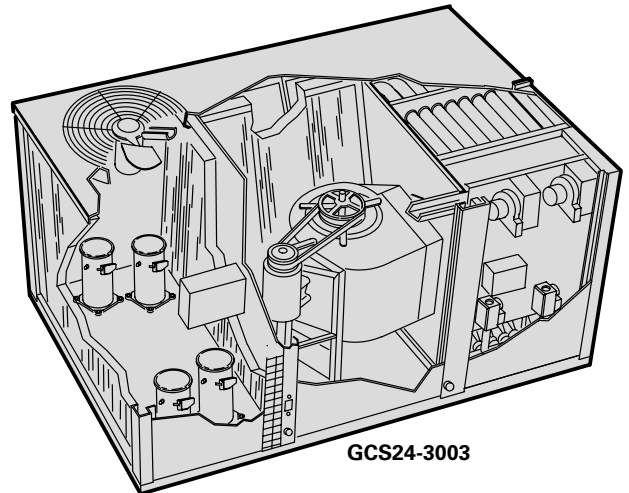

GCS24-3003

Table of Contents

Features	Page 2
Accessories	Page 3
Temperature Control Systems	Page 4-5
Temperature Control Flowcharts	Page 6-7
Specifications	Page 8-9
Field Installed Accessories	Page 10-11
High Altitude Derate	Page 11
Factory Installed Options Selection	Page 11-12
Electrical Data	Page 13
Field Wiring	Page 14
Cooling Ratings	Page 15-16
Blower Data	Page 17-21
Guide Specifications	Page 22
Dimensions - GCS24-953	Page 23-25
Dimensions - GCS24-1353-1603	Page 26-28
Dimensions - GCS24-3003	Page 29-31
Dimensions - Accessories	Page 32-35
Installation Clearances	Page 36

FEATURES

Item	GCS24-953	GCS24-1353	GCS24-1603	GCS24-3003
Air Flow Choice — Bottom (down-flow) or horizontal (side) supply and return air	Std.	Std.	Std.	Std.
Approvals — A.G.A./C.G.A. certified as combination heating/ cooling unit for outdoor installation, bonded for grounding to meet safety standards for servicing required by A.G.A./C.G.A. and National and Canadian Electrical Codes	Std.	Std.	Std.	Std.
ARI Standard 210/240-89 Certified	Std.	Std.	—	—
ARI Standard 360-86 Certified	—	—	Std.	▲
Sound Rating — Tested in accordance with conditions included in ARI 270	Std.	Std.	Not Applicable	
Bottom Power Entry	†Opt.	†Opt.	Std.	Std.
Cabinet — Heavy gauge galvanized steel, fully insulated, powdered enamel paint finish, large removeable access panels, electrical inlets in cabinet base and condenser section, hinged control box with factory installed controls low voltage terminal strip, unit lifting brackets	Std.	Std.	Std.	Std.
Cabinet Panels — 2 compressor panels, 2 blower panels and 1 gas heat access panel hinged with quarter-turn latches	—	—	—	●Opt.
Coil Construction (Evaporator and Condenser) — Copper tube construction, ripple-edged enhanced aluminum fins, flared shoulder tubing connections, silver soldered construction, factory tested, evaporator coil face split with separate circuits, evaporator coil drain connection outside of unit cabinet.	Std.	Std.	Std.	Std.
Compressors — Reciprocating type, hermetically sealed, suction cooled, overload protected	Std.	—	Std.	—
Compressors — Copeland® Compliant Scroll™ type, hermetically sealed, discharge temperature thermostat (protects compressor)	—	Std.	—	—
Compressors — Bristol® Inertia™ type, hermetically sealed, overload protected	—	—	—	Std.
Compressor Crankcase Heaters	Std.	Std.	—	Std.
Condenser Coils — Formed coil construction	Std.	—	—	—
Condenser Coils — Slab coil construction	—	Std.	Std.	Std.
Condenser Fans — Low sound operating levels, PVC coated fan guard furnished	Std.	Std.	Std.	Std.
Condenser Fan Motors — Overload protected, permanently lubricated, ball bearings	Std.	Std.	Std.	Std.
Control Box — Hinged for easy access, factory installed	*Opt.	Std.	Std.	Std.
Corrosion Protection — Phenolic epoxy coating applied to condenser coil only (with painted base section) or to both condenser and evaporator coils (with painted condenser and evaporator base section and painted blower housings), factory applied	**Opt.	**Opt.	**Opt.	**Opt.
Disconnect — Factory installed	*Opt.	*Opt.	*Opt.	*Opt.
Fan and Limit Controls — Factory installed, 90 second fan time delay, dual limit controls (primary and secondary) with fixed temperature setting	Std.	Std.	Std.	Std.
Filters — Disposable 2 inch (51 mm) commercial grade, filter rack will accept 1 inch (25 mm) thick filters	Std.	Std.	Std.	Std.
Filter Access — Hinged filter door with quarter turn fasteners	Std.	Std.	Std.	Std.
Heat Exchanger — Tubular construction, aluminized steel, life cycle tested	Std.	Std.	Std.	Std.
Heating System — Aluminized Steel inshot burners, direct spark ignition, electronic flame sensor, redundant automatic dual gas valve with manual shut-off, induced draft blower, flame rollout switch, peep hole for flame viewing	Std.	Std.	Std.	Std.
Low Ambient Controls — Allows unit operation down to 30°F (–1°C)	†Opt.	Std.	Std.	Std.
Refrigeration System — Consists of: compressors, condenser coil and direct drive fan(s), evaporator coil and belt drive blower, expansion valves, high capacity driers, thermomometer wells, high pressure switches, low pressure switches, full refrigerant charge, freezestat (prevents coil freeze-up during low ambient operation), independent refrigerant circuits (allows staging)	Std.	Std.	Std.	Std.
Service Outlets (2) — Factory installed, 120v ground fault circuit interrupter (GFCI) type	*Opt.	*Opt.	*Opt.	*Opt.
Supply Air Blower — Belt drive, forward curved blades with double inlet, blower wheel statically and dynamically balanced, permanently lubricated sleeve bearings, adjustable pulley (allows speed change)	Std.	Std.	Std.	Std.
Supply Air Motor — Overload protected, equipped with ball bearings	Std.	Std.	Std.	Std.
Warranty — Limited ten years heat exchanger, limited five years compressors, one year all other components, see limited warranty certificate included with unit for details	Std.	Std.	Std.	Std.

Std.= Standard with unit.

Opt.= Optional

▲ Tested at conditions included in ARI Standard 360.

*Available as part of factory installed Electrical Convenience Package, see Optional Factory Installed Options tables.

**Available factory installed Corrosion Protection Package, see Optional Factory Installed Options table.

● Available factory installed Hinged Panel Package, see Optional Factory Installed Options tables.

† Available for field installation, see Optional Field Installed Accessories tables. Also part of factory installed Electrical Convenience Package, see Factory Installed Options tables.

OPTIONAL ACCESSORIES (Must Be Ordered Extra)

Item	GCS24-953	GCS24-1353	GCS24-1603	GCS24-3003
❖ Cold Weather Kit — Electric heater automatically controls minimum temperature in gas burner compartment when temperature is below -40°F (-40°C). C.G.A. certified to allow operation of unit down to -60°F (-50°C)	Opt.	Opt.	Opt.	Opt.
Control System — Electro-mechanical Thermostat	Opt.	Opt.	Opt.	Opt.
Control System — W973	Opt.	Opt.	Opt.	Opt.
Control System — T7300 Thermostat	Opt.	Opt.	Opt.	Opt.
Control System — W7400	Opt.	Opt.	Opt.	Opt.
Control System — T8600 and T8621 Thermostat	Opt.	Opt.	Opt.	Opt.
Differential Enthalpy Control — For use with economizer dampers, solid-state return air sensor allows selection between outdoor air and return air (whichever has lowest enthalpy)	Opt.	Opt.	Opt.	Opt.
Diffusers (Step-Down) — Aluminum grilles, double deflection louvers, large center grille, insulated diffuser box with flanges, hanging rings furnished, interior transition (even air flow), internally sealed (prevents recirculation), adapts to T-bar ceiling grids or plaster ceilings	RTD11-95	RTD11-135	RTD11-185	RTD11-275
Diffusers (Flush) — Aluminum grilles, fixed blade louvers, large center grille, insulated diffuser box with flanges, hanging rings furnished, interior transition (even air flow), internally sealed (prevents recirculation), adapts to T-bar ceiling grids or plaster ceilings	FD11-95	FD11-135	FD11-185	FD11-275
Transitions (Supply and Return) — Used with diffusers, installs in roof mounting frame, galvanized steel construction, flanges furnished for duct connection, fully insulated	SRT16-95	SRT16-135	SRT16-160	SRT16-300
Economizer Dampers — Mechanically linked recirculated air and outdoor air dampers, plug-in connections to unit, nylon bearings, stainless steel seals (outdoor dampers), 24 volt fully modulating spring return damper motor, adjustable minimum damper position switch, mixed air controller, solid-state adjustable outdoor air enthalpy control, 0 to 100% outdoor air adjustable	†Opt.	†Opt.	†Opt.	†Opt.
Economizer Dampers (Down-Flow) — Cleanable aluminum mesh frame filter furnished, gravity exhaust air dampers furnished, fresh air and exhaust air hoods furnished for field installation, powdered enamel paint finish	†REMD24M-95	†REMD24M-135	†REMD24M-160	—
Economizer Dampers (Horizontal) — Two cleanable polyurethane frame filters furnished, galvanized steel cabinet, flanged air openings on return air section, outdoor air hood shipped separately, powdered enamel paint finish, fully insulated, requires optional Horizontal Supply and Return Air Kit for duct connection NOTE — Installation requires field modification to filter access door	EMDH16M-95	EMDH16M-135	EMDH16M-160	—
Economizer Dampers (Down-Flow or Horizontal) — Two cleanable polyurethane frame filters furnished, damper assembly installs in unit, outdoor air hood installs over outdoor air dampers, gravity exhaust dampers furnished, horizontal applications require Horizontal Supply and Return Air Kit	—	—	—	†REMD16M-300
Economizer Gravity Exhaust Dampers (Horizontal) — For use with EMDH16 horizontal economizer damper sections, two neoprene coated fiberglass dampers furnished, rainhoods furnished, bird screen furnished		GED16-95/135/160		
Horizontal Supply and Return Air Kit — Provides duct connection to unit, flanges furnished, hardware furnished, two filler panels furnished for unused air openings, filter access panel furnished	Opt.	Opt.	Opt.	Opt.
LPG/Propane Kits	Opt.	Opt.	Opt.	Opt.
Outdoor Air Damper Section — Linked mechanical dampers, interchangeable unit panel furnished (down-flow applications), two-piece cabinet (control access), cleanable polyurethane frame type filter furnished, 0 to 25% (fixed) outdoor air adjustable, manual or automatic operation (kit required for automatic operation), installs on unit for down-flow applications, installs in return air duct for horizontal applications	OAD24-95	OAD24-135	OAD24-160	OAD16-300
Outdoor Air Damper Automatic Damper Kit — 3 position damper actuator, plug-in connection	Opt.	Opt.	Opt.	Opt.
Power Exhaust Fans — Install on economizer dampers in down-flow applications, provide pressure relief, interlocked to run when return air dampers are closed and supply air blowers are operating, overload protected	—	—	—	PED16-300
Roof Mounting Frame — Nailer strip furnished, mates to unit, U.S. National Roofing Contractors Approved, shipped knocked down	RMF16-95	RMF16-135/160		RMF16-300
Smoke Detector — Photoelectric type, factory installed in return air section	*Opt.	*Opt.	*Opt.	*Opt.
Timed-Off Control — Prevents compressor short-cycling, contains two controls	Opt.	Opt.	Opt.	Opt.

Opt.= Optional. See Optional Field Installed Accessories tables for ordering information.

†Available for field installation, see Field Installed Accessories tables. Also available as factory installed Economizer Package, see Factory Installed Options tables.

*Available factory installed Smoke Detector Package, see Factory Installed Options tables.

OPTIONAL TEMPERATURE CONTROL SYSTEMS (See Flow Charts on Pages 6 and 7)

System and Component Description	Catalog No.
ELECTRO-MECHANICAL THERMOSTAT CONTROL SYSTEM	
Thermostat — Two stage heat & two stage cool with dual temperature levers, subbase choice	13F06
Subbase — Manual system switch (Off-Heat-Auto-Cool), fan switch (Auto-On)	13F17
Subbase — Non-switching	13F16
Night Setback Operation — Order components below	—
Heating Thermostat — Single stage heat	13F12
Subbase — Non-switching	13F16
Nite Kit — Required if economizer is not used, contains plug-in relay, overrides operation of day thermostat	39G74
Time Clock — 7 day operation, indicates day and night periods, 2 hour increments, battery back-up	See Price Book for Selection
Time Clock — 24 hour night setback operation, 15 minute increments, battery back-up	See Price Book for Selection
Warm Up Kit — Holds economizer dampers closed during night heating operation and morning warm-up	39G77
Cycle Control (Required) — Plug-in connections, provides timed-on and off function, prevents compressor short cycling, not required on GCS24-3003 units.	42H51
W973 CONTROL SYSTEM	
Logic Panel/Discharge Sensor/Plug-in Relay — Panel controls operation of economizer and stages of heating and cooling in response to signals from thermostat, balances conditioned space thermostat demand against system output, system output measured by discharge sensor (furnished), combined demand and output signals determine economizer damper position and number of cooling or heating stages required, logic panel may be installed in unit or remotely located, W973 Plug-in Relay (furnished) adapts control system to unit	39G76
Thermostat — Dual setpoint, separate heating-cooling levers, locking setpoints, integral sensor	25C52
Subbase — Switching with system selector switch (Heat-Auto-Off-Cool), fan switch (Auto-On)	58C93
Transmitter — Dual setpoint, separate heating-cooling levers, locking setpoints, requires sensor	25C51
Subbase — Switching with system selector switch (Heat-Auto-Off-Cool), fan switch (Auto-On)	58C93
Sensor — Room temperature	58C92
Sensor — Return air temperature	27C40
Time Clock — 7 day operation, indicates day and night periods, 2 hour increments, battery back-up	See Price Book for Selection
Time Clock — 24 hour night setback operation, 15 minute increments, battery back-up	See Price Book for Selection
Warm Up Kit — Holds economizer dampers closed during night heating operation and morning warm-up	39G77
T7300 THERMOSTAT CONTROL SYSTEM	
Thermostat — Programmable, internal or optional remote temperature sensing (sensor required), touch sensitive keyboard, automatic switching, °F or °C readout, no anticipator, droop/no droop selection, indicator LED's, hour/day programming, override capabilities, time and operational mode readout, stage status indicators, battery back-up, subbase choice	81G59
Subbase — Selectable staging up to two stage heat & two stage cool, manual system switch (Heat-Off-Auto-Cool), fan switch (Auto-On), indicator LED's, auxiliary relay output for economizer operation	81G60
Subbase — Selectable staging up to three stage heat & two stage cool, manual system switch (Auto-Cool-Off-Heat-Emergency Heat) (heat pump only), fan switch (Auto-On), indicator LED's, auxiliary relay output for economizer operation	13H76
Sensor — Room temperature	58C92
Sensor — Room temperature with 3 hour override and setpoint adjustment	86G67
Sensor — Return air temperature	27C40

OPTIONAL TEMPERATURE CONTROL SYSTEMS (See Flow Charts on Pages 6 and 7)

System and Component Description	Catalog No.
W7400 CONTROL SYSTEM	—
Control Module/Plug-in Relay — Module controls operation of economizer and stages of heating and cooling, setpoint/space temperature sensor and time-of-day signals control unit operation, module balances space temperature signal against stages operating to determine system output, system output is measured and updated by monitoring actual space temperature deviation from setpoint and rate of change of space temperature, module may be installed in unit or remotely located, plug-in relay (furnished) provides set points for economizer and DX cooling, choice of thermostats	74G11
Thermostat — Room thermostat with integral sensor, touch sensitive keyboard, automatic switching, no anticipator, zero droop, indicator lights, hour/day programming, override capabilities, time readout, stage status indicators, battery back-up, wiring wallplate	36G62 (°F) or 36G63 (°C)
Thermostat — Remote thermostat (sensor required), touch sensitive keyboard, automatic switching, no anticipator, zero droop, indicator lights, hour/day programming, override capabilities, time readout, stage status indicators, battery back-up, wiring wallplate	36G64 (°F) or 36G65 (°C)
Sensor — Room temperature	58C92
Sensor — Return air temperature	27C40
T8600 and T8621 THERMOSTAT CONTROL SYSTEMS	—
Thermostats — Built-in time delays, system switch (Heat-Off-Cool-Auto), fan switch (Auto-On), touch sensitive keyboard, LCD display (Time-Day-Status-Temperature readout in °F or °C), four different time and temperature settings per day, T8621 has switching subbase and one LED (system “On”), T8600 has wiring wall plate and two LED’s (Energy Savings and system “On”), both have instant override capabilities for skipping current program, running previous program, temporarily raising or lowering temperature for current program or overriding program indefinitely, three “AAA” battery back-up, see below for additional descriptions	See left for catalog numbers
⚡ T8600C1055 71E91 Manual changeover, 1 htg./1 clg. 5-1-1 day programming T8600D1079 27H31 Auto changeover, 1 htg./1 clg. 5-1-1 day programming ⚡ T8621A7010 75E25 Auto changeover, 1 htg./1 clg. 7 day programming T8621D7055 27H29 Auto changeover, 2 htg./2 clg. 7 day programming	
Warm Up Kit — Holds economizer dampers closed during night heating operation and morning warm-up	39G77

LOGIC CONTROLS PACKAGE (Factory Installed Option)

Component Description	Catalog No.
ETM Electronic Thermostat Module — Factory installed control monitors unit operation from different sensors factory installed in unit, has outputs for 2 stage heat/2 stage cool, automatic or continuous blower operation, economizer damper operation and night setback, features: day/occupied mode with low enthalpy (outdoor air damper open), high enthalpy (outdoor air damper closed) or night/unoccupied mode (outdoor air damper closed), ETM allows units to be “daisy chained” together (up to 31 units) to be operated from one central location with an “executive” type control processor (onsite or offsite), built-in time delays, built-in unit operating defaults, diagnostic LED’s indicate various operating functions, surge suppression protects ETM against lightning or voltage spikes	Factory Installed In Unit
Return Air Sensor — Provides input to ETM module to determine heating or cooling operation and number of stages required	Factory Installed In Unit
Blower Proving Switch — Monitors blower operation, locks out unit in case of blower failure, sends signal to ETM module for alarm	Factory Installed In Unit
Dirty Filter Switch — Senses static pressure increase indicating a dirty filter condition	Factory Installed In Unit
Discharge Air Monitor — Senses leaving air temperature for monitoring unit operation	Factory Installed In Unit
Room Temperature Sensor — Provides input to ETM module to determine heating or cooling operation and number of stages required (ordered separately)	97H53
Night Setback Override Switch — Allows momentary override of night setback during unoccupied mode	Field Furnished

TEMPERATURE CONTROL SELECTION FLOWCHARTS

OPTIONAL ELECTRO-MECHANICAL THERMOSTAT CONTROL SYSTEM

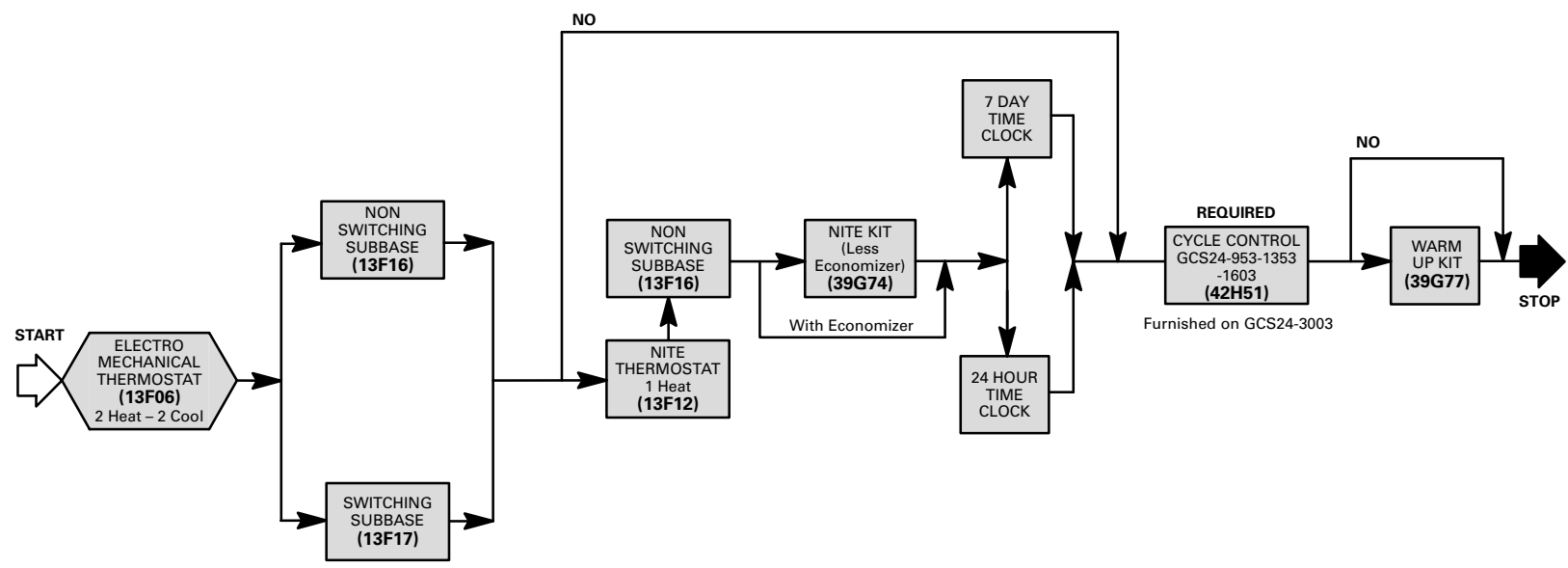

OPTIONAL W973 CONTROL SYSTEM

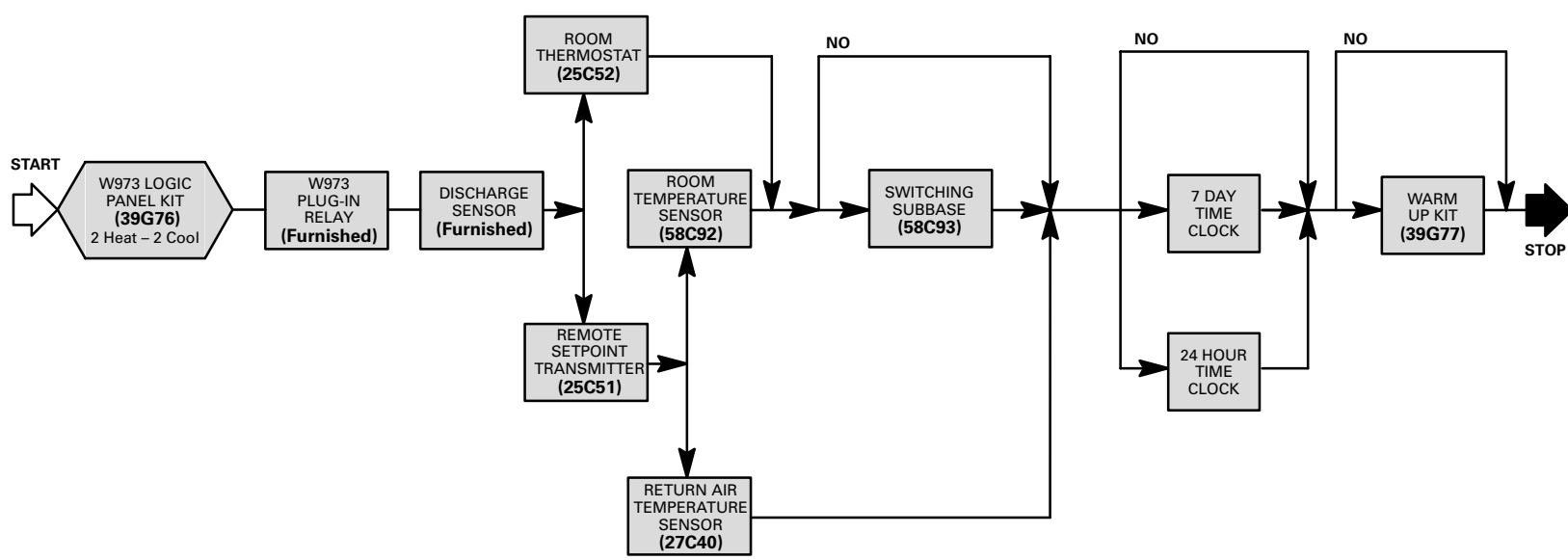

TEMPERATURE CONTROL SELECTION FLOWCHARTS

OPTIONAL T7300 CONTROL SYSTEM

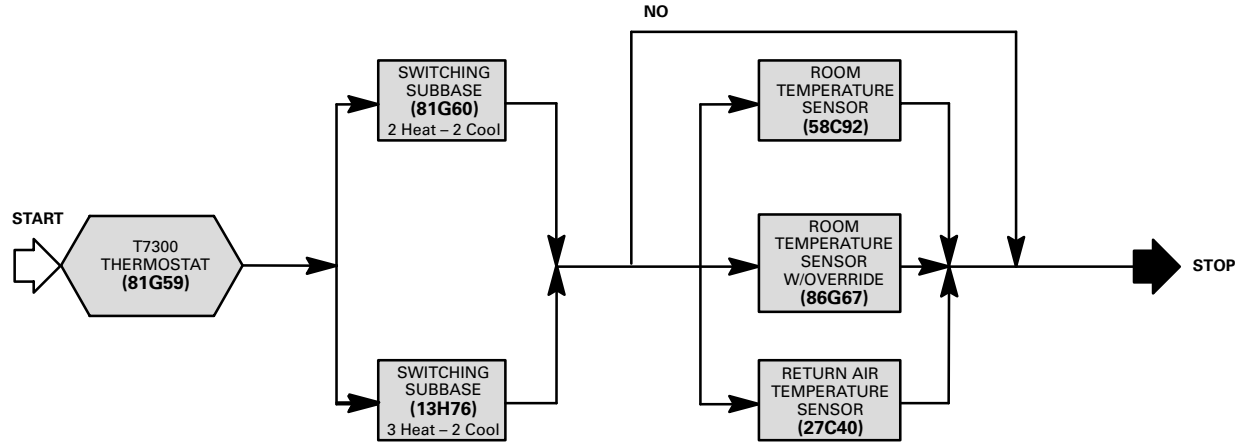

OPTIONAL W7400 CONTROL SYSTEM

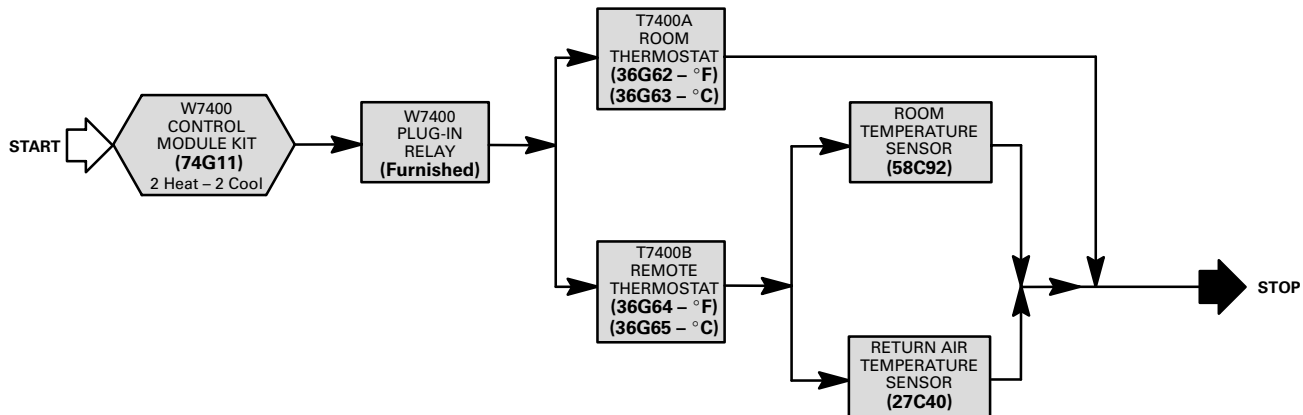

OPTIONAL T8600 OR T8621 THERMOSTAT CONTROL SYSTEM

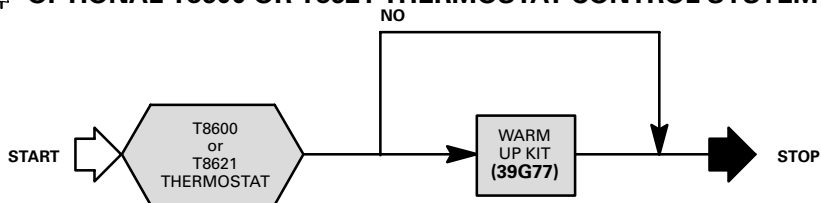

OPTIONAL LOGIC CONTROLS PACKAGE (Factory Installed)

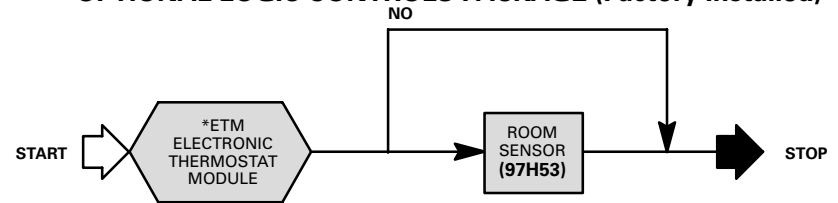

*Includes Return Air Sensor, Blower Proving Switch, Dirty Filter Switch and Discharge Air Monitor factory installed in unit.

SPECIFICATIONS — GCS24-953 and GCS24-1353

Model No.		GCS24-953	GCS24-1353	
Cooling Ratings	Gross cooling capacity — Btuh (kW)	92,800 (27.2)	123,700 (36.2)	
	*Total cooling capacity — Btuh (kW)	88,000 (25.8)	119,000 (34.9)	
	*Total unit watts	8800	11,780	
	*EER (Btuh/Watts)	10.0	10.1	
	*†Integrated Part Load Value	10.0	9.8	
	* Sound Rating Number (Bels)	8.6	8.4	
Refrigerant Charge (HCFC-22)	Circuit 1	6 lbs. 0 oz. (2.72 kg)	11 lbs. 0 oz. (4.99 kg)	
	Circuit 2	6 lbs. 0 oz. (2.72 kg)	11 lbs. 0 oz. (4.99 kg)	
Evaporator Blower and Drive Selection	Blower wheel nominal dia. x width — in. (mm)		12 x 12 (305 x 305)	15 x 15 (381 x 381)
	Factory Installed ***Drives	Nominal motor hp (W)	2 (1492)	3 (2238)
		Maximum usable hp (W)	2.30 (1716)	3.45 (2574)
		Voltage & phase	208/230/460v or 575v-3ph	208/230/460v or 575v-3ph
		RPM range	740 — 1010	730 — 950
Evaporator Coil	Net face area — sq. ft. (m ²)		7.75 (0.72)	9.46 (0.88)
	Tube diameter — in. (mm) & No. of rows		3/8 (9.5) — 3	3/8 (9.5) — 4
	Fins per inch (m)		14 (551)	12 (472)
	Expansion device type		Thermostatic Expansion Valve	
	Drain connection size mpt — in. (mm) PVC		1 (25.4)	1 (25.4)
Condenser Coil	Net face area — sq. ft. (m ²)		15.67 (1.46)	30.25 (2.81)
	Tube diameter — in. (mm) & No. of rows		3/8 (9.5) — 2	3/8 (9.5) — 2
	Fins per inch (m)		20 (787)	20 (787)
Condenser Fan(s)	Diameter — in. (mm) & No. of blades		(1) 24 (610) — 4	(2) 22 (559) — 5
	Air volume — cfm (L/s)		5150 (2430)	8800 (4155) Total
	Motor horsepower (W)		(1) 3/4 (560)	(2) 1/2 (373)
	Motor rpm		1075	1075
	Motor watts		650	995 Total
Sea Level Two Stage Heating Capacity (Natural Gas Only)	Input (low) — Btuh (kW)		126,000 (36.9)	170,000 (49.8)
	Output (low) — Btuh (kW)		98,000 (28.7)	132,500 (38.8)
	Input (High) — Btuh (kW)		200,000 (58.6)	270,000 (79.1)
	Output (High) — Btuh (kW)		160,000 (46.9)	216,000 (63.3)
	A.G.A./C.G.A. Thermal Efficiency		80%	80%
Sea Level Two Stage Heating Capacity (**LPG/Propane Gas Only)	Input (low) — Btuh (kW)		126,000 (36.9)	170,000 (49.8)
	Output (low) — Btuh (kW)		98,000 (28.7)	132,500 (38.8)
	Input (High) — Btuh (kW)		175,000 (51.3)	236,250 (69.2)
	Output (High) — Btuh (kW)		142,600 (41.8)	192,500 (56.4)
	A.G.A./C.G.A. Thermal Efficiency		81.5%	81.5%
⊕ High Altitude Two Stage Heating Capacity (Natural Gas Only)	Input (low) — Btuh (kW)		126,000 (36.9)	170,000 (49.8)
	Output (low) — Btuh (kW)		98,000 (28.7)	132,500 (38.8)
	Input (High) — Btuh (kW)		192,000 (56.3)	254,000 (74.4)
	Output (High) — Btuh (kW)		153,600 (45.0)	203,200 (59.5)
	C.G.A. Thermal Efficiency		80%	80%
⊕ High Altitude Two Stage Heating Capacity (**LPG/Propane Gas Only)	Input (low) — Btuh (kW)		126,000 (36.9)	170,000 (49.8)
	Output (low) — Btuh (kW)		98,000 (28.7)	132,500 (38.8)
	Input (High) — Btuh (kW)		175,000 (51.3)	235,000 (68.9)
	Output (High) — Btuh (kW)		142,600 (41.8)	191,525 (56.1)
	C.G.A. Thermal Efficiency		81.5%	81.5%
Gas Supply Connections fpt — in. (mm)	Natural	3/4 (19)	3/4 (19)	
	**LPG/Propane	3/4 (19)	3/4 (19)	
Recommended Gas Supply Pressure — wc. in. (kPa)	Natural	7 (1.7)	7 (1.7)	
	**LPG/Propane	11 (2.7)	11 (2.7)	
Filters (furnished)	Type of filter	Disposable, commercial grade		
	No. & size — in. (mm)	(4) 16 x 20 x 2 (406 x 508 x 51)	(4) 16 x 25 x 2 (406 x 635 x 51)	
Net weight of basic unit — lbs. (kg)		875 (397)	1254 (569)	
Shipping weight of basic unit — lbs. (kg) (1 Package)		1060 (481)	1345 (610)	
Electrical characteristics		208/230v, 460v or 575v — 60 hertz — 3 phase		

*Sound Rating Number in accordance with test conditions included in ARI Standard 270.

*Rated in accordance with ARI Standard 210/240; 95°F (35°F) outdoor air temperature and 80°F (27°C) db/67°F (19°C) wb entering evaporator air.

†Integrated Part Load Value rated at 80°F (27°C) outdoor air temperature.

NOTE — ARI capacity is net and includes evaporator blower motor heat deduction. Gross capacity does not include evaporator blower motor heat deduction.

**For LPG/Propane units a field conversion kit is required and must be ordered extra. See Optional Accessories table.

***Using total air volume and system static pressure requirements determine from blower performance tables rpm and motor output required. Maximum usable output of motors furnished by Lennox are shown. In Canada, nominal motor output is also maximum usable motor output. If motors of comparable output are used, be sure to keep within the service factor limitations outlined on the motor nameplate.

SPECIFICATIONS — GCS24-1603 AND GCS24-3003

Model No.		GCS24-1603	GCS24-3003-235	GCS24-3003-470	
Cooling Ratings	Gross cooling capacity — Btuh (kW)	150,700 (44.2)	294,600 (86.3)		
	*Total cooling capacity — Btuh (kW)	144,000 (42.2)	▲289,000 (84.7)		
	*Total unit watts	15,500	▲31,100		
	*EER (Btuh/Watts)	9.3	▲9.0		
	*†Integrated Part Load Value	10.3	▲9.1		
	*Sound Rating Number (bels)	8.8	----		
Refrigerant Charge-HCFC-22	Each Circuit and Number of Circuits	11 lbs. 8 oz. (5.22 kg) — 2	10 lbs. 4 oz. (4.65 kg) — 4		
Evaporator Blower and Drive Selection	Blower wheel nominal dia. x width — in. (mm)	15 x 15 (381 x 381)	20 x 18 (508 x 457)		
	Factory Installed ***Drives	Nominal motor hp (W)	3 (2238)	7.5 (5595)	
		Maximum usable hp (W)	3.45 (2574)	8.6 (6415)	
		Voltage & phase	208/230v, 460v or 575v-3ph		
		RPM range	730 — 950	610 — 780	
	Optional Factory Installed ***Drives	Nominal motor hp (W)	----	10 (7460)	
		Maximum usable hp (W)	----	11.5 (8580)	
		Voltage & phase	----	208/230v, 460v or 575v-3ph	
RPM range		----	770 — 980		
Evaporator Coil	Net face area — sq. ft. (m ²)	11.9 (1.11)	21.0 (1.95)		
	Tube diameter — in. (mm) & No. of rows	3/8 (9.5) — 3	3/8 (9.5) — 3		
	Fins per inch (m)	12 (472)	13 (512)		
	Expansion device type	Thermostatic Expansion Valve			
	Drain connection size mpt — in. (mm) PVC	1 (25.4)	(2) 1 (25.4)		
Condenser Coil	Net face area — sq. ft. (m ²)	30.25 (2.81)	48.5 (4.51)		
	Tube diameter — in. (mm) & No. of rows	3/8 (9.5) — 2	3/8 (9.5) — 3		
	Fins per inch (m)	20 (787)	16 (630)		
Condenser Fans	Diameter — in. (mm) & No. of blades	(2) 22 (559) — 4	(2) 26 (660) — 5		
	Air volume — cfm (L/s)	8800 (4155) Total	14,500 (6845) total		
	Motor horsepower (W)	(2) 1/2 (373)	(2) 1 (746)		
	Motor rpm & Motor watts	1075 — 995 Total	1130 — 2200 Total		
Sea Level Two Stage Heating Capacity (Natural Gas Only)	Input (low) — Btuh (kW)	170,000 (49.8)	145,000 (42.5)	290,000 (85.0)	
	Output (low) — Btuh (kW)	132,500 (38.8)	116,000 (34.0)	232,000 (68.0)	
	Input (High) — Btuh (kW)	270,000 (79.1)	235,000 (68.9)	470,000 (137.7)	
	Output (High) — Btuh (kW)	216,000 (63.3)	188,000 (55.1)	376,000 (110.2)	
	A.G.A./C.G.A. Thermal Efficiency	80%	80%	80%	
Sea Level Two Stage Heating Capacity (**LPG/Propane Gas Only)	Input (low) — Btuh (kW)	170,000 (49.8)	164,000 (48.1)	328,000 (96.1)	
	Output (low) — Btuh (kW)	132,500 (38.8)	131,200 (38.4)	262,400 (76.9)	
	Input (High) — Btuh (kW)	236,250 (69.2)	235,000 (68.9)	470,000 (137.7)	
	Output (High) — Btuh (kW)	192,500 (56.4)	188,000 (55.1)	376,000 (110.2)	
	A.G.A./C.G.A. Thermal Efficiency	81.5%	80%	80%	
⊕ High Altitude Two Stage Heating Capacity (Natural Gas Only)	Input (low) — Btuh (kW)	170,000 (49.8)	145,000 (42.5)	290,000 (85.0)	
	Output (low) — Btuh (kW)	132,500 (38.8)	116,000 (34.0)	232,000 (68.0)	
	Input (High) — Btuh (kW)	254,000 (74.4)	235,000 (68.9)	470,000 (137.7)	
	Output (High) — Btuh (kW)	203,200 (59.5)	188,000 (55.1)	376,000 (110.2)	
	C.G.A. Thermal Efficiency	80%	80%	80%	
⊕ High Altitude Two Stage Heating Capacity (**LPG/Propane Gas Only)	Input (low) — Btuh (kW)	170,000 (49.8)	164,000 (48.1)	328,000 (96.1)	
	Output (low) — Btuh (kW)	132,500 (38.8)	131,200 (38.4)	262,400 (76.9)	
	Input (High) — Btuh (kW)	235,000 (68.9)	235,000 (68.9)	470,000 (137.7)	
	Output (High) — Btuh (kW)	191,525 (56.1)	188,000 (55.1)	376,000 (110.2)	
	C.G.A. Thermal Efficiency	81.5%	80%	80%	
Gas Supply Connections fpt — in. (mm) Natural and **LPG/Propane		3/4 (19)	3/4 (19)	1 (25.4)	
Rec. Gas Supply Pressure — in. w.g. (kPa) Natural and **LPG/Propane		7 (1.7)	7 (1.7)		
Filters (furnished)	Type of filter	Disposable, commercial grade			
	No. & size of filters — in. (mm)	(4) 20x25x2 (508x635x25)	(6) 20 x 25 x 2 (508 x 635 x 51)		
Net weight of basic unit — lbs. (kg)		1313 (596)	2880 (1306)	3080 (1397)	
Shipping weight of basic unit — lbs. (kg) (1 Package)		1500 (680)	3155 (1431)	3355 (1522)	
Electrical characteristics		208/230v, 460v or 575v — 60 hertz — 3 phase			

*Sound Rating Number in accordance with test condition included in ARI Standard 270.

*Rated in accordance with ARI Standard 360; 95°F (35°F) outdoor air temperature and 80°F (27°C) db/67°F (19°C) wb entering evaporator air.

▲Testing conditions are those included in ARI Standard 360-86.

†Integrated Part Load Value rated at 80°F (27°C) outdoor air temperature.

NOTE — ARI capacity is net and includes evaporator blower motor heat deduction. Gross capacity does not include evaporator blower motor heat deduction.

**For LPG/Propane units a field conversion kit is required and must be ordered extra. See Optional Accessories table.

***Using total air volume and system static pressure requirements determine from blower performance tables rpm and motor output required. Maximum usable output of motors furnished by Lennox are shown. In Canada, nominal motor output is also maximum usable motor output. If motors of comparable output are used, be sure to keep within the service factor limitations outlined on the motor nameplate.

OPTIONAL FIELD INSTALLED ACCESSORIES — GCS24-953 and GCS24-1353

Unit Model No.		GCS24-953	GCS24-1353	
LPG/Propane Conversion Kit		LB-55755DA (32G88)		
ϕ Cold Weather Kit		65C03		
Roof Mounting Frame — (Net Weight)		RMF16-95 (107 lbs.) (49 kg)	RMF16-135/160 (119 lbs.) (54 kg)	
Down-Flow Economizer Dampers with Gravity Exhaust	Model No. (Net Weight)	REMD24M-95 (60 lbs.) (27 kg)	REMD24M-135 (80 lbs.) (36 kg)	
	Net face area	2.1 sq. ft. (0.20 m ²)	2.8 sq. ft. (0.26 m ²)	
	No. & size of filters	in.	(1) 32-1/4 x 16-1/2 x 1	(1) 32-1/4 x 21-1/2 x 1
mm		(1) 819 x 419 x 25	(1) 819 x 546 x 25	
Horizontal Economizer Dampers	Model No. (Net Weight)	EMDH16M-95 (120 lbs.) (54 kg)	EMDH16M-135 (137 lbs.) (62 kg)	
	No. & size of filters	in.	(2) 16 x 25 x 1	(2) 16 x 25 x 1
		mm	(2) 406 x 635 x 25	(2) 406 x 635 x 25
Exhaust Dampers — (Net Weight) — Net Face Area		GED16-95/135/160 (5 lbs.) (2 kg) — 0.43 sq. ft. (0.04 m ²) used with EMDH16		
Differential Enthalpy Control		54G44		
Horizontal Supply and Return Air Kit — (Net Weight)		LB-55756BA (34G71) (30 lbs.) (14 kg)	LB-55756BB (35G42) (35 lbs.) (16 kg)	
Bottom Power Entry Kit — (Net Weight)		LB-55757CA (34G70) (12 lbs.) (5 kg)		
Ceiling Supply and Return Air Diffusers (Net Weight)	Step-Down	RTD11-95 (125 lbs.) (57 kg)	RTD11-135 (125 lbs.) (57 kg)	
	Flush	FD11-95 (95 lbs.) (43 kg)	FD11-135 (95 lbs.) (43 kg)	
	Transition	SRT16-95 (38 lbs.) (17 kg)	SRT16-135 (38 lbs.) (17 kg)	
Outdoor Air Dampers	Model No. (Net Weight)	OAD24-95 (41 lbs.) (19 kg)	OAD24-135 (43 lbs.) (20 kg)	
	No. & size of filters — in. (mm)	(1) 16 x 20 x 1 (406 x 508 x 25)	(1) 16 x 20 x 1 (406 x 508 x 25)	
Automatic Damper Kit — (Net Weight)		35G21 (7 lbs.) (3 kg)		
Timed-Off Control Kit (2) LB-50709BA		40G20		
Low Ambient Control Kit		LB-57113BG (15J80)	Furnished	

OPTIONAL FIELD INSTALLED ACCESSORIES — GCS24-1603

Unit Model No.		GCS24-1603	
LPG/Propane Conversion Kit		LB-55755DA (32G88)	
ϕ Cold Weather Kit		65C03	
Roof Mounting Frame — (Net Weight)		RMF16-135/160 (119 lbs.) (54 kg)	
Economizer Dampers with Gravity Exhaust	Model No. (Net Weight)	REMD24M-160 (100 lbs.) (45 kg)	
	Net face area	3.6 sq. ft. (0.33 m ²)	
	No. & size of filters	in.	(1) 40-1/4 x 21-1/2 x 1
mm		(1) 1022 x 546 x 25	
Horizontal Economizer Dampers	Model No. (Net Weight)	EMDH16M-160 (147 lbs.) (67 kg)	
	No. & size of filters	in.	(2) 20 x 25 x 1
		mm	(2) 508 x 635 x 25
Exhaust Dampers — (Net Weight) — Net Face Area		GED16-95/135/160 (5 lbs.) (2 kg) — 0.43 sq. ft. (0.04 m ²) used with EMDH16	
Differential Enthalpy Control		54G44	
Horizontal Supply and Return Air Kit — (Net Weight)		LB-55756BC (51G27) (42 lbs.) (19 kg)	
Ceiling Supply and Return Air Diffusers (Net Weight)	Step-Down	RTD11-185 (392 lbs.) (178 kg)	
	Flush	FD11-185 (289 lbs.) (131 kg)	
	Transition	SRT16-160 (70 lbs.) (32 kg)	
Outdoor Air Dampers	Model No. (Net Weight)	OAD24-160 (45 lbs.) (20 kg)	
	No. & size of filters — in. (mm)	(1) 16 x 20 x 1 (406 x 508 x 25)	
Automatic Damper Kit — (Net Weight)		35G21 (7 lbs.) (3 kg)	
Timed-Off Control Kit (2) LB-50709BA		40G20	

OPTIONAL FIELD INSTALLED ACCESSORIES – GCS24-3003

Unit Model No.		GCS24-3003	
LPG/Propane Conversion Kit		LB-81509DA (12H31) (2 required on -470)	
❖ Cold Weather Kit		65C03	
Roof Mounting Frame – (Net Weight)		RMF16-300 (180 lbs.) (82 kg)	
Economizer Dampers with Gravity Exhaust	Model No. (Net Weight)		REMD16M-300 (210 lbs.) (95 kg)
	No. & size of filters	in.	(3) 20 x 25 x 1
		mm	(3) 508 x 635 x 25
Differential Enthalpy Control		54G44	
Optional Power Exhaust Fans (Down-Flo Only)	Model No. (Net Weight)		PED16-300 (91 lbs.) (41 kg)
	Diameter – in.(mm) & No. of Blades		(3) 16 (406) – 5
	Total air volume – cfm (L/s)		6300 (2975)
	Motor Horsepower (W)		(3) 1/4 (187)
	Watts input (total)		750
Horizontal Supply and Return Air Kit – (Net Weight)		LB-55756BE (60 lbs.) (27 kg) (41H23)	
Ceiling Supply and Return Air Diffusers (Net Weight)	Step-Down		RTD11-275 (403 lbs.) (183 kg)
	Flush		FD11-275 (363 lbs.) (165 kg)
	Transition		SRT16-300 (120 lbs.) (54 kg)
Outdoor Air Dampers – (Net Weight) No. & size of filters – in. (mm)		OAD16-300 (84 lbs.) (38 kg) (1) 26 x 31 x 1 (660 x 787 x 25)	
Automatic OAD16 Damper Kit – (Net Weight)		35G21 (7 lbs.) (3 kg)	
Timed-Off Control (2) LB-50709BA		40G20	

HIGH ALTITUDE DERATE

A.G.A. certified units must be derated when installed at an elevation of more than 2000 feet (610 m) above sea level. If unit is installed at an altitude higher than 2000 feet (610 m), the unit must be derated 4% for every 1000 feet (305 m) above sea level. Thus, at an altitude of 4000 feet (1210 m), the unit would require a derate of 16%.

❖ C.G.A. certified units must be derated when installed at an elevation of more than 2000 feet (610 m) above sea level. If unit is installed at an altitude higher than 2000 feet (610 m), the unit must be derated 10% for elevations between 2000 feet and 4500 feet (610 m and 1370 m) above sea level.

NOTE – This is the only permissible derate for these units.

FACTORY INSTALLED OPTIONS SELECTION

GCS24-953

Packaged Unit Model No.	Voltage Selection 3 phase 60hz	Electrical Convenience Package (D)	Economizer Package (E) or (G)	Smoke Detector Package (S)	Corrosion Protection Package (T) or (U)
GCS24-953 Basic unit includes: –2 hp (1492W) Blower Motor –200,000 Btuh (58.6 kW) Gas Heating Input –Hinged Filter Access	208/230v	Unit Disconnect, Bottom Power Entry and Low Ambient Controls Installed and Wired. Dual 120v GFCI Service Outlets, (Field Wired) Hinged Control Box Panel	Down-Flow Economizer With Gravity Exhaust Installed and Wired (E) Enthalpy Controlled or (G) Globally Controlled	Photoelectric Smoke Detector Installed and Wired In Return Air Section	Corrosion Resistant Coating Applied To Both Condenser And Evaporator Coils With Painted Base in Condensing And Evaporator Sections And Painted Blower Housing (U) Or Condenser Coil Only With Painted Base Condensing Section(T)
	460V				
	575v				

FACTORY INSTALLED OPTIONS SELECTION

GCS24-1353

Packaged Unit Model No.	Voltage Selection 3 phase 60hz	Electrical Convenience Package (D)	Economizer Package (E) or (G)	Smoke Detector Package (S)	Corrosion Protection Package (T) or (U)
GCS24-1353 Basic unit includes: -3 hp (2238W) -Blower Motor -270,000 Btuh (79.1 kW) -Gas Heating Input -Hinged Control Box -Hinged Filter Access -Low Ambient Controls	208/230v	Unit Disconnect, and Bottom Power Entry Installed and Wired Dual 120v GFCI Service Outlets, (Field Wired)	Down-Flow Economizer With Gravity Exhaust Installed and Wired (E) Enthalpy Controlled or (G) Globally Controlled	Photoelectric Smoke Detector Installed and Wired In Return Air Section	Corrosion Resistant Coating Applied To Both Condenser And Evaporator Coils With Painted Base in Condensing And Evaporator Sections And Painted Blower Housing (U) Or Condenser Coil Only With Painted Base Condensing Section(T)
	460V				
	575v				

GCS24-1603

Packaged Unit Model No.	Voltage Selection 3 phase 60hz	Electrical Convenience Package (D)	Economizer Package (E) or (G)	Smoke Detector Package (S)	Corrosion Protection Package (T) or (U)
GCS24-1603 Basic unit includes: -3 hp (2238W) -Blower Motor -270,000 Btuh (79.1 kW) -Gas Heating Input -Hinged Control Box -Hinged Filter Access -Low Ambient Controls -Bottom Power Entry	208/230v	Unit Disconnect Installed and Wired and Dual 120v GFCI Service Outlets (Field Wired)	Down-Flow Economizer With Gravity Exhaust Installed and Wired (E) Enthalpy Controlled or (G) Globally Controlled	Photoelectric Smoke Detector Installed and Wired In Return Air Section	Corrosion Resistant Coating Applied To Both Condenser And Evaporator Coils With Painted Base in Condensing And Evaporator Sections And Painted Blower Housing (U) Or Condenser Coil Only With Painted Base Condensing Section(T)
	460V				
	575v				

GCS24-3003

Packaged Unit Model No.	Voltage Selection 3 phase 60hz	Blower Motor (Select One)	Gas Heat Btuh (kW) (Select One)	Electrical Convenience Package (D)	Economizer Package (E) or (G)	Smoke Detector Package (S)	Hinged Panel Package (H)	Corrosion Protection Package (T) or (U)
GCS24-3003 Basic unit includes: -Hinged Control Box -Hinged Filter Access -Bottom Power Entry -Low Ambient Controls	208/230v	7.5 hp (5595)	235,000 (68.9)	Unit Disconnect Installed and Wired. Dual 120v GFCI Service Outlets (Field Wired)	Down-Flow Economizer With Gravity Exhaust Installed and Wired (E) Enthalpy Controlled or (G) Globally Controlled	Photoelectric Smoke Detector Installed and Wired In Return Air Section	Two Compressor Panels, Two Blower Panels And One Gas Heat Service Panel Hinged With Quarter Turn Latches	Corrosion Resistant Coating Applied To Both Condenser And Evaporator Coils With Painted Base in Condensing And Evaporator Sections And Painted Blower Housing (U) Or Condenser Coil Only With Painted Base Condensing Section(T)
		10 hp (7460)	470,000 (137.7)					
	460V	7.5 hp (5595)	235,000 (68.9)					
		10 hp (7460)	470,000 (137.7)					
	575v	7.5 hp (5595)	235,000 (68.9)					
		10 hp (7460)	470,000 (137.7)					

All MODELS

Packaged Unit Model No.	Logic Controls Package (L)
All Models	Controls for Logic control system factory installed

ELECTRICAL DATA — GCS24-953 & GCS24-1353

Model No.		GCS24-953			GCS24-1353			
Line voltage data — 60 Hz — 3 phase		208/230v	460v	575v	208/230v	460v	575v	
Compressors (2)	Rated load amps — each (total)	14.1 (28.2)	7.1 (14.2)	5.8 (11.6)	17.3 (34.6)	9.0 (18.0)	7.1 (14.2)	
	Locked rotor amps — each (total)	130 (260.0)	64 (128.0)	52 (104.0)	123 (246.0)	62 (124.0)	50 (100.0)	
Condenser Fan Motor(s) (1) -953 (2) -1353	Full load amps — each (total)	3.7	1.9	1.6	3.0 (6.0)	1.5 (3.0)	1.2 (2.4)	
	Locked rotor amps — each (total)	7.3	3.7	2.9	6.0 (12.0)	3.0 (6.0)	2.9 (5.8)	
Evaporator Blower Motor	Motor Output	hp	2	2	2	3	3	3
		W	1492	1492	1492	2238	2238	2238
	Full load amps		7.5	3.4	2.7	10.6	4.8	3.9
	Locked rotor amps		41.0	20.4	16.2	58.0	26.8	23.4
Recommended maximum fuse size (amps)		50	25	20	70	35	25	
Service Outlets (2) 120 volt GFCI (amp rating)		20	20	20	20	20	20	
*Minimum Circuit Ampacity		43.0	22.0	18	56.0	29.0	23.0	
Unit power factor		.88	.88	.88	.88	.88	.88	

*Refer to National or Canadian Electrical Code manual to determine wire, fuse and disconnect size requirements.
NOTE — Extremes of operating range are plus and minus 10 % of line voltage.

ELECTRICAL DATA — GCS24-1603 and GCS24-3003

Model No.		GCS24-1603			GCS24-3003						
Line voltage data — 60 hz — 3 phase		208/230v	460v	575v	208/230v		460v		575v		
Compressors (2) -1603 (4) -3003	Rated load amps — each (total)	20.8 (41.6)	8.1 (16.2)	6.5 (13.0)	21.8 (87.2)		12.2 (48.8)		9.0 (36.0)		
	Locked rotor amps — each (total)	142.0 (284.0)	72 (144.0)	58 (116.0)	158.0 (632.0)		82.0 (328.0)		68 (272.0)		
Condenser Fan Motors (2)	Full load amps (total)	6.0	3.0	2.4	9.6		4.8		4.0		
	Locked rotor amps (total)	12.0	6.0	5.8	46.0		23.0		17.8		
Evaporator Blower Motor	Motor Output	hp	3	3	3	7.5	10	7.5	10	7.5	10
		W	2238	2238	2238	5595	7460	5595	7460	5595	7460
	Full load amps (total)		10.6	4.8	3.9	24.2	30.8	11.0	14.0	9.0	11.0
	Locked rotor amps (total)		58.0	26.8	23.4	152.0	193.0	66.0	84.0	54.0	66.0
Optional Power Exhaust Fans	(No.) Horsepower (W)	----	----	----	(3) — 1/4 (187)						
	Full load amps (total)	----	----	----	4.2		2.2		2.1		
	Locked rotor amps (total)	----	----	----	8.7		3.9		4.2		
Rec. max. fuse size (amps)	With Exhaust Fans	----	----	----	150	150	80	80	60	60	
	Less Exhaust Fans	80	30	25	150	150	70	80	60	60	
*Minimum Circuit Ampacity	With Exhaust Fans	----	----	----	131.0	140.0	69.0	73.0	53.0	56.0	
	Less Exhaust Fans	64.0	26.0	21.0	127.0	136.0	67.0	71.0	51.0	54.0	
Service Outlets (2) 120 volt GFCI (amp rating)		20	20	20	20		20		20		
Unit Power Factor		.88	.88	.88	.89		.89		.89		

*Refer to National or Canadian Electrical Code manual to determine wire, fuse and disconnect size requirements.
NOTE — Extremes of operating range are plus and minus 10 % of line voltage.

W973 CONTROL SYSTEM

- A — Three wire power (See Electrical Data Table)
- B — Seven wire low voltage — DC only
- C — Two wire low voltage — AC only — with switching subbase
- D — Two wire low voltage — DC only
- E — Two wire power
- F — Two wire low voltage — AC only
- G — Two wire power (120 volt)

AC — Alternating current
DC — Direct current

NOTE — Run separate harness for AC and DC.
AC voltage interferes with DC signals.

— *Field wiring not furnished* —

NOTE — All wiring must conform to NEC or CEC and local electrical codes.

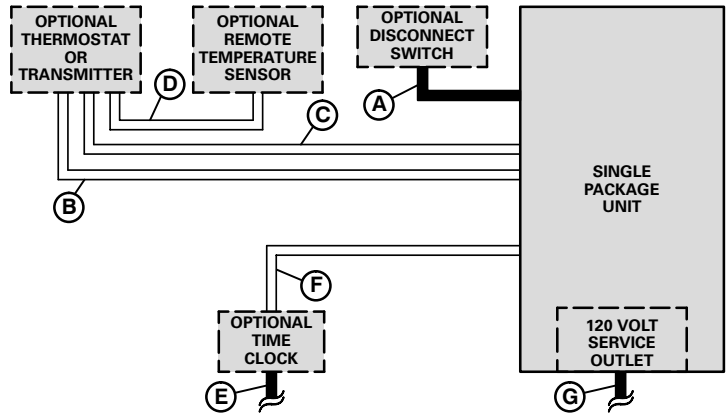

ELECTRO-MECHANICAL THERMOSTAT CONTROL SYSTEM

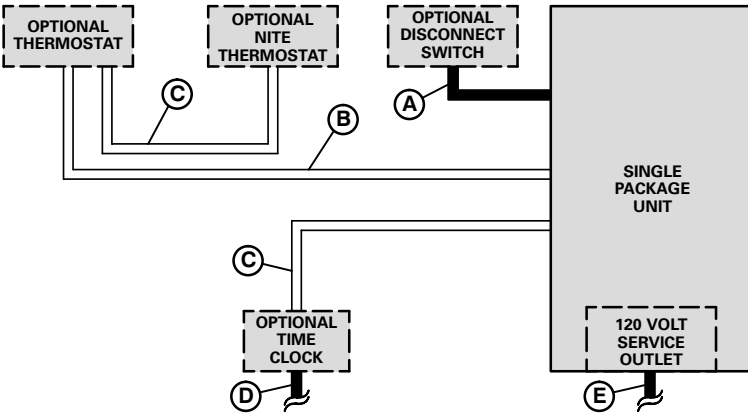

- A — Three wire power (See Electrical Data Table)
- B — Six wire low voltage
- C — Two wire low voltage
- D — Two wire power
- E — Two wire power (120 volt)

— *Field wiring not furnished* —

NOTE — All wiring must conform to NEC or CEC and local electrical codes.

W7400 CONTROL SYSTEM

- A — Three wire power (See Electrical Data Table)
- B — Two wire low voltage
- C — Four wire low voltage
- D — Two wire power (120 volt)

— *Field wiring not furnished* —

NOTE — All wiring must conform to NEC or CEC and local electrical codes.

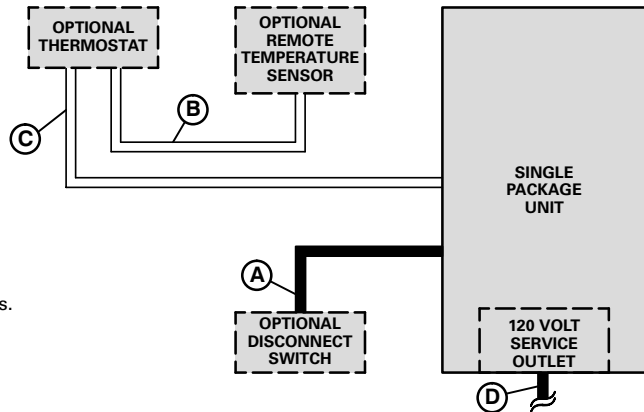

T8600 OR T8621 THERMOSTAT OR T7300 THERMOSTAT CONTROL SYSTEM

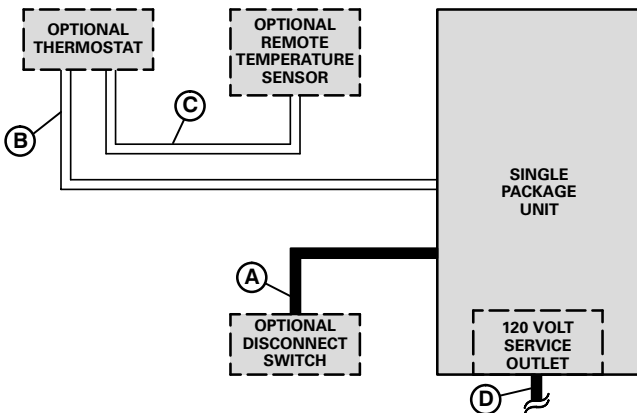

- A — Three wire power (See Electrical Data Table)
- B — Nine wire low voltage
- C — Two wire low voltage
- Seven wire low voltage (T7300 Room Sensor with override)
- D — Two wire power (120 volt)

— *Field wiring not furnished* —

NOTE — All wiring must conform to NEC or CEC and local electrical codes.

RATINGS

NOTE — For Temperatures and Capacities not shown in tables, see bulletin — Cooling Unit Rating Table Correction Factor Data in Miscellaneous Engineering Data section.

GCS24-953 COOLING CAPACITY (With One Compressor Only Operating)

Entering Wet Bulb Temperature	Total Air Volume		Outdoor Air Temperature Entering Condenser Coil																							
			65°F (18°C)						75°F (24°C)						85°F (29°C)						95°F (35°C)					
			Total Cooling Capacity		Compressor Motor Watts Input	Sensible To Total Ratio (S/T)			Total Cooling Capacity		Compressor Motor Watts Input	Sensible To Total Ratio (S/T)			Total Cooling Capacity		Compressor Motor Watts Input	Sensible To Total Ratio (S/T)			Total Cooling Capacity		Compressor Motor Watts Input	Sensible To Total Ratio (S/T)		
						Dry Bulb						Dry Bulb						Dry Bulb						Dry Bulb		
L/s	cfm	kW	Btuh	75°F/24°C	80°F/27°C	85°F/29°C	kW	Btuh	75°F/24°C	80°F/27°C	85°F/29°C	kW	Btuh	75°F/24°C	80°F/27°C	85°F/29°C	kW	Btuh	75°F/24°C	80°F/27°C	85°F/29°C					
63°F (17.2°C)	1180	2500	14.3	48,900	2800	.72	.84	.96	13.8	47,000	3060	.73	.86	.97	13.2	45,000	3330	.74	.88	.99	12.6	43,000	3600	.75	.89	1.00
	1415	3000	14.8	50,600	2810	.75	.89	1.00	14.2	48,500	3080	.76	.91	1.00	13.6	46,500	3350	.78	.93	1.00	13.0	44,500	3630	.80	.95	1.00
	1650	3500	15.2	51,900	2820	.79	.94	1.00	14.6	49,900	3090	.80	.95	1.00	14.0	47,800	3370	.82	.97	1.00	13.4	45,800	3660	.84	.99	1.00
67°F (19.4°C)	1180	2500	15.3	52,300	2820	.56	.69	.81	14.7	50,200	3090	.57	.70	.82	14.1	48,100	3380	.58	.71	.84	13.5	46,000	3660	.58	.72	.86
	1415	3000	15.8	53,900	2830	.58	.72	.86	15.1	51,700	3110	.59	.74	.88	14.5	49,500	3390	.60	.75	.89	13.8	47,200	3680	.61	.77	.91
	1650	3500	16.1	55,000	2830	.60	.76	.90	15.5	52,800	3110	.61	.78	.92	14.8	50,500	3410	.62	.79	.94	14.1	48,200	3700	.64	.81	.96
71°F (21.7°C)	1180	2500	16.4	56,100	2840	.43	.54	.66	15.8	53,900	3120	.43	.55	.67	15.1	51,700	3420	.43	.56	.68	14.5	49,500	3720	.43	.57	.70
	1415	3000	16.9	57,600	2840	.43	.57	.70	16.2	55,300	3130	.44	.57	.71	15.5	53,000	3430	.44	.58	.73	14.9	50,700	3740	.44	.59	.74
	1650	3500	17.2	58,800	2840	.44	.59	.74	16.5	56,400	3140	.45	.60	.75	15.8	54,000	3440	.45	.61	.77	15.1	51,700	3760	.45	.62	.79

NOTE — All values are gross capacities and do not include evaporator coil blower motor heat deduction.

GCS24-953 TOTAL COOLING CAPACITY (With Both Compressors Operating)

Entering Wet Bulb Temperature	Total Air Volume		Outdoor Air Temperature Entering Condenser Coil																							
			85°F (29°C)						95°F (35°C)						105°F (41°C)						115°F (46°C)					
			Total Cooling Capacity		Compressor Motor Watts Input	Sensible To Total Ratio (S/T)			Total Cooling Capacity		Compressor Motor Watts Input	Sensible To Total Ratio (S/T)			Total Cooling Capacity		Compressor Motor Watts Input	Sensible To Total Ratio (S/T)			Total Cooling Capacity		Compressor Motor Watts Input	Sensible To Total Ratio (S/T)		
						Dry Bulb						Dry Bulb						Dry Bulb						Dry Bulb		
L/s	cfm	kW	Btuh	75°F/24°C	80°F/27°C	85°F/29°C	kW	Btuh	75°F/24°C	80°F/27°C	85°F/29°C	kW	Btuh	75°F/24°C	80°F/27°C	85°F/29°C	kW	Btuh	75°F/24°C	80°F/27°C	85°F/29°C					
63°F (17.2°C)	1180	2500	26.8	91,300	6570	.71	.86	.98	25.1	85,500	6990	.73	.88	1.00	22.5	76,900	7390	.77	.91	1.00	21.5	73,300	7890	.78	.93	1.00
	1415	3000	27.6	94,100	6650	.75	.92	1.00	25.8	88,200	7090	.78	.94	1.00	23.3	79,400	7510	.82	.97	1.00	22.2	75,800	8030	.84	.98	1.00
	1650	3500	28.3	96,600	6740	.80	.97	1.00	26.6	90,700	7190	.83	.99	1.00	24.0	81,800	7630	.86	1.00	1.00	22.9	78,300	8170	.88	1.00	1.00
67°F (19.4°C)	1180	2500	28.4	96,800	6740	.55	.69	.82	26.5	90,600	7180	.57	.71	.85	23.9	81,500	7610	.59	.74	.88	22.7	77,600	8130	.60	.76	.90
	1415	3000	29.1	99,200	6820	.58	.73	.89	27.2	92,800	7270	.60	.76	.91	24.4	83,400	7700	.62	.79	.94	23.3	79,400	8230	.63	.81	.96
	1650	3500	29.6	101,000	6880	.61	.78	.94	27.7	94,500	7340	.63	.81	.96	24.9	85,000	7780	.65	.84	.98	23.7	80,900	8320	.67	.86	1.00
71°F (21.7°C)	1180	2500	30.2	103,100	6950	.41	.54	.66	28.3	96,600	7420	.42	.55	.69	25.5	86,900	7870	.43	.58	.72	24.3	82,900	8420	.44	.59	.73
	1415	3000	30.9	105,300	7020	.42	.57	.71	28.9	98,600	7500	.43	.59	.74	26.0	88,700	7960	.45	.61	.77	24.8	84,500	8520	.45	.62	.79
	1650	3500	31.3	106,900	7080	.43	.59	.75	29.3	100,100	7560	.44	.62	.79	26.4	90,000	8030	.46	.64	.82	25.1	85,700	8590	.46	.66	.84

NOTE — All values are gross capacities and do not include evaporator coil blower motor heat deduction.

GCS24-1353 COOLING CAPACITY (With One Compressor Only Operating)

Entering Wet Bulb Temperature	Total Air Volume		Outdoor Air Temperature Entering Condenser Coil																							
			65°F (18°C)						75°F (24°C)						85°F (29°C)						95°F (35°C)					
			Total Cooling Capacity		Compressor Motor Watts Input	Sensible To Total Ratio (S/T)			Total Cooling Capacity		Compressor Motor Watts Input	Sensible To Total Ratio (S/T)			Total Cooling Capacity		Compressor Motor Watts Input	Sensible To Total Ratio (S/T)			Total Cooling Capacity		Compressor Motor Watts Input	Sensible To Total Ratio (S/T)		
						Dry Bulb						Dry Bulb						Dry Bulb						Dry Bulb		
L/s	cfm	kW	Btuh	75°F/24°C	80°F/27°C	85°F/29°C	kW	Btuh	75°F/24°C	80°F/27°C	85°F/29°C	kW	Btuh	75°F/24°C	80°F/27°C	85°F/29°C	kW	Btuh	75°F/24°C	80°F/27°C	85°F/29°C					
63°F (17.2°C)	1650	3500	17.7	60,500	3480	.71	.85	.97	17.1	58,500	3790	.71	.86	.98	16.6	56,700	4170	.72	.87	1.00	16.0	54,600	4640	.73	.89	1.00
	2005	4250	18.5	63,100	3510	.75	.90	1.00	17.9	61,200	3820	.76	.91	1.00	17.3	59,200	4200	.77	.93	1.00	16.6	56,800	4660	.78	.95	1.00
	2360	5000	19.1	65,100	3540	.79	.94	1.00	18.3	62,600	3850	.80	.97	1.00	17.8	60,600	4220	.81	.98	1.00	17.1	58,300	4690	.83	1.00	1.00
67°F (19.4°C)	1650	3500	18.8	64,000	3530	.56	.70	.82	18.2	62,100	3830	.56	.71	.83	17.6	60,200	4210	.56	.71	.84	17.0	58,000	4680	.57	.73	.86
	2005	4250	19.6	66,800	3560	.58	.73	.88	19.0	64,800	3860	.59	.74	.89	18.4	62,800	4240	.59	.75	.90	17.7	60,400	4720	.60	.76	.92
	2360	5000	20.3	69,100	3570	.61	.77	.93	19.6	66,900	3880	.61	.78	.94	18.9	64,600	4270	.62	.79	.96	18.2	62,000	4750	.63	.81	.98
71°F (21.7°C)	1650	3500	19.9	67,800	3560	.42	.56	.69	19.3	65,800	3870	.42	.57	.70	18.7	63,800	4260	.42	.57	.70	18.0	61,500	4740	.42	.58	.71
	2005	4250	20.7	70,800	3590	.43	.58	.73	20.1	68,700	3900	.43	.59	.74	19.5	66,500	4290	.43	.59	.75	18.8	64,000	4770	.43	.60	.76
	2360	5000	21.4	73,000	3610	.44	.60	.77	20.7	70,700	3930	.44	.61	.78	20.0	68,300	4320	.44	.62	.79	19.3	65,700	4800	.45	.63	.80

NOTE — All values are gross capacities and do not include evaporator coil blower motor heat deduction.

GCS24-1353 TOTAL COOLING CAPACITY (With Both Compressors Operating)

Entering Wet Bulb Temperature	Total Air Volume		Outdoor Air Temperature Entering Condenser Coil																							
			85°F (29°C)						95°F (35°C)						105°F (41°C)						115°F (46°C)					
			Total Cooling Capacity		Compressor Motor Watts Input	Sensible To Total Ratio (S/T)			Total Cooling Capacity		Compressor Motor Watts Input	Sensible To Total Ratio (S/T)			Total Cooling Capacity		Compressor Motor Watts Input	Sensible To Total Ratio (S/T)			Total Cooling Capacity		Compressor Motor Watts Input	Sensible To Total Ratio (S/T)		
						Dry Bulb						Dry Bulb						Dry Bulb						Dry Bulb		
L/s	cfm	kW	Btuh	75°F/24°C	80°F/27°C	85°F/29°C	kW	Btuh	75°F/24°C	80°F/27°C	85°F/29°C	kW	Btuh	75°F/24°C	80°F/27°C	85°F/29°C	kW	Btuh	75°F/24°C	80°F/27°C	85°F/29°C					
63°F (17.2°C)	1650	3500	35.4	121,000	8200	.69	.85	.98	33.0	112,700	9290	.76	.91	1.00	31.6	107,900	10,250	.78	.94	1.00	29.2	99,500	11,440	.79	.96	1.00
	2005	4250	36.9	126,000	8250	.73	.91	1.00	34.1	116,300	9340	.80	.97	1.00	32.6	111,400	10,310	.83	1.00	1.00	30.1	102,600	11,490	.84	1.00	1.00
	2360	5000	38.0	129,800	8290	.78	.97	1.00	35.1	119,800	9380	.83	.99	1.00	33.5	114,300	10,360	.88	1.00	1.00	30.9	105,600	11,560	.90	1.00	1.00
67°F (19.4°C)	1650	3500	37.7	128,500	8280	.54	.67	.81	35.1	119,900	9380	.59	.73	.87	33.7	114,900	10,360	.61	.77	.91	31.1	106,100	11,570	.61	.78	.92
	2005	4250	39.2	133,800	8340	.57	.71	.87	36.6	124,800	9460	.62	.77	.93	34.8	118,800	10,450	.64	.81	.97	32.2	109,900	11,660	.65	.83	.99
	2360	5000	40.3	137,400	8390	.59	.75	.94	37.4	127,800	9520	.64	.81	.98	35.8	122,200	10,500	.67	.86	1.00	33.0	112,600	11,720	.68	.88	1.00
71°F (21.7°C)	1650	3500	39.8	135,900	8370	.41	.53	.67	37.2	127,000	9500	.43	.58	.73	35.7	121,700	10,490	.45	.60	.76	32.9	112,400	11,710	.45	.61	.77
	2005	4250	41.4	141,300	8440	.42	.56	.71	38.7	132,100	9570	.44	.61	.77	36.9	126,000	10,570	.46	.63	.80	34.1	116,300	11,800	.47	.64	.82
	2360	5000	42																							

RATINGS

NOTE — For Temperatures and Capacities not shown in tables, see bulletin — Cooling Unit Rating Table Correction Factor Data in Miscellaneous Engineering Data section.

GCS24-1603 COOLING CAPACITY (With One Compressor Only Operating)

Entering Wet Bulb Temperature	Total Air Volume		Outdoor Air Temperature Entering Condenser Coil																							
			65°F (18°C)			75°F (24°C)			85°F (29°C)			95°F (35°C)														
			Total Cooling Capacity		Compressor Motor Watts Input	Sensible To Total Ratio (S/T) Dry Bulb			Total Cooling Capacity		Compressor Motor Watts Input	Sensible To Total Ratio (S/T) Dry Bulb			Total Cooling Capacity		Compressor Motor Watts Input	Sensible To Total Ratio (S/T) Dry Bulb								
			L/s	cfm		kW	Btuh	75°F 24°C	80°F 27°C	85°F 29°C		kW	Btuh	75°F 24°C	80°F 27°C	85°F 29°C		kW	Btuh	75°F 24°C	80°F 27°C	85°F 29°C	kW	Btuh	75°F 24°C	80°F 27°C
63°F (17.2°C)	1980	4200	22.4	76,500	4620	.59	.73	.85	21.5	73,300	5030	.60	.74	.87	20.6	70,300	5470	.61	.76	.89	19.6	67,000	5960	.62	.77	.91
	2360	5000	23.5	80,200	4670	.62	.76	.91	22.5	76,900	5100	.63	.78	.93	21.5	73,400	5560	.65	.80	.96	20.5	70,000	6040	.66	.82	.99
	2735	5800	24.3	83,000	4720	.66	.80	.97	23.3	79,500	5150	.67	.82	1.00	22.3	76,000	5610	.69	.84	1.00	21.2	72,400	6110	.70	.86	1.00
67°F (19.4°C)	1980	4200	23.7	80,700	4680	.47	.59	.70	22.7	77,400	5110	.47	.60	.72	21.7	74,200	5580	.48	.61	.73	20.8	71,000	6070	.48	.62	.75
	2360	5000	24.7	84,400	4740	.48	.61	.75	23.7	81,000	5180	.49	.62	.77	22.7	77,600	5650	.50	.63	.78	21.7	74,100	6160	.50	.65	.80
	2735	5800	25.6	87,300	4780	.50	.64	.80	24.6	83,800	5230	.51	.65	.81	23.5	80,200	5710	.52	.66	.83	22.4	76,600	6220	.53	.68	.86
71°F (21.7°C)	1980	4200	24.9	84,900	4750	.35	.48	.58	23.9	81,600	5190	.35	.49	.59	22.9	78,200	5670	.35	.49	.60	22.0	74,900	6180	.36	.50	.61
	2360	5000	26.0	88,700	4800	.36	.49	.61	24.9	85,100	5250	.36	.50	.62	23.9	81,600	5740	.36	.50	.63	22.9	78,100	6260	.36	.51	.64
	2735	5800	26.8	91,400	4840	.36	.51	.64	25.8	87,900	5300	.37	.51	.65	24.7	84,300	5800	.37	.52	.67	23.6	80,600	6330	.37	.53	.68

NOTE — All values are gross capacities and do not include evaporator coil blower motor heat deduction.

GCS24-1603 TOTAL COOLING CAPACITY (With Both Compressors Operating)

Entering Wet Bulb Temperature	Total Air Volume		Outdoor Air Temperature Entering Condenser Coil																							
			85°F (29°C)			95°F (35°C)			105°F (41°C)			115°F (46°C)														
			Total Cooling Capacity		Compressor Motor Watts Input	Sensible To Total Ratio (S/T) Dry Bulb			Total Cooling Capacity		Compressor Motor Watts Input	Sensible To Total Ratio (S/T) Dry Bulb			Total Cooling Capacity		Compressor Motor Watts Input	Sensible To Total Ratio (S/T) Dry Bulb								
			L/s	cfm		kW	Btuh	75°F 24°C	80°F 27°C	85°F 29°C		kW	Btuh	75°F 24°C	80°F 27°C	85°F 29°C		kW	Btuh	75°F 24°C	80°F 27°C	85°F 29°C	kW	Btuh	75°F 24°C	80°F 27°C
63°F (17.2°C)	1980	4200	41.8	143,800	11,230	.66	.83	.98	40.3	137,400	12,180	.68	.85	.99	37.3	127,200	13,050	.69	.87	1.00	34.3	117,200	13,920	.71	.90	1.00
	2360	5000	43.7	149,000	11,380	.70	.89	1.00	41.8	142,700	12,340	.72	.90	1.00	38.7	132,000	13,230	.73	.92	1.00	35.4	120,900	14,100	.76	.96	1.00
	2735	5800	45.0	153,700	11,490	.75	.95	1.00	42.7	145,700	12,450	.77	.96	1.00	39.4	134,600	13,330	.78	.97	1.00	36.3	124,000	14,250	.81	1.00	1.00
67°F (19.4°C)	1980	4200	44.5	151,800	11,450	.52	.65	.80	42.7	145,700	12,440	.53	.66	.82	39.5	134,700	13,350	.54	.68	.83	36.5	124,600	14,270	.55	.71	.85
	2360	5000	46.1	157,400	11,580	.54	.69	.85	44.2	151,000	12,590	.55	.71	.87	40.9	139,500	13,530	.56	.72	.89	37.7	128,600	14,460	.58	.75	.92
	2735	5800	47.4	161,800	11,680	.56	.73	.92	45.4	155,000	12,710	.57	.75	.94	41.9	142,900	13,660	.58	.76	.95	38.6	131,800	14,630	.60	.79	.98
71°F (21.7°C)	1980	4200	46.8	159,700	11,640	.39	.52	.65	45.0	153,600	12,670	.40	.53	.66	41.6	142,100	13,630	.40	.54	.67	38.6	131,700	14,590	.41	.55	.69
	2360	5000	48.4	165,300	11,770	.40	.54	.68	46.6	158,900	12,820	.40	.55	.69	43.1	147,100	13,790	.41	.56	.71	39.8	135,900	14,770	.42	.58	.74
	2735	5800	49.8	169,900	11,870	.40	.56	.72	47.8	163,000	12,920	.41	.57	.73	44.2	150,700	13,920	.42	.58	.75	40.8	139,300	14,910	.43	.60	.78

NOTE — All values are gross capacities and do not include evaporator coil blower motor heat deduction.

GCS24-3003 COOLING CAPACITY (With Two Compressors Only Operating)

Entering Wet Bulb Temperature	Total Air Volume		Outdoor Air Temperature Entering Condenser Coil																							
			65°F (18°C)			75°F (24°C)			85°F (29°C)			95°F (35°C)														
			Total Cooling Capacity		Compressor Motor Watts Input	Sensible To Total Ratio (S/T) Dry Bulb			Total Cooling Capacity		Compressor Motor Watts Input	Sensible To Total Ratio (S/T) Dry Bulb			Total Cooling Capacity		Compressor Motor Watts Input	Sensible To Total Ratio (S/T) Dry Bulb								
			L/s	cfm		kW	Btuh	75°F 24°C	80°F 27°C	85°F 29°C		kW	Btuh	75°F 24°C	80°F 27°C	85°F 29°C		kW	Btuh	75°F 24°C	80°F 27°C	85°F 29°C	kW	Btuh	75°F 24°C	80°F 27°C
63°F (17.2°C)	4010	8500	44.9	153,100	9690	.63	.77	.90	43.1	147,100	10,390	.63	.78	.92	41.3	141,000	11,130	.65	.80	.94	39.5	134,700	11,880	.66	.82	.96
	4720	10,000	46.2	157,700	9790	.66	.82	.95	44.4	151,400	10,510	.67	.84	.97	42.5	145,100	11,270	.69	.86	.99	40.7	138,800	12,050	.71	.88	1.00
	5425	11,500	47.3	161,300	9860	.70	.86	1.00	45.4	154,900	10,600	.71	.89	1.00	43.6	148,700	11,390	.73	.92	1.00	41.7	142,400	12,200	.75	.94	1.00
67°F (19.4°C)	4010	8500	47.6	162,400	9880	.50	.61	.72	45.7	155,900	10,620	.51	.61	.74	43.8	149,600	11,420	.51	.62	.76	41.9	143,000	12,230	.51	.63	.78
	4720	10,000	48.7	166,300	9940	.51	.63	.78	46.9	159,900	10,720	.52	.64	.80	44.9	153,200	11,550	.52	.66	.82	43.0	146,700	12,370	.53	.68	.84
	5425	11,500	49.8	169,600	10,010	.53	.67	.83	47.7	162,800	10,800	.54	.68	.85	45.7	156,100	11,630	.55	.71	.88	43.8	149,400	12,490	.56	.72	.90
71°F (21.7°C)	4010	8500	50.5	172,500	10,050	.38	.48	.58	48.6	165,900	10,880	.38	.49	.59	46.7	159,400	11,740	.38	.49	.60	44.7	152,600	12,420	.39	.50	.61
	4720	10,000	51.7	176,300	10,110	.39	.50	.61	49.8	169,800	10,960	.39	.51	.62	47.7	162,900	11,850	.39	.51	.63	45.7	156,000	12,740	.39	.52	.65
	5425	11,500	52.5	179,300	10,150	.40	.52	.65	50.5	172,500	11,020	.40	.52	.66	48.5	165,600	11,940	.40	.53	.68	46.4	158,500	12,850	.40	.54	.70

NOTE — All values are gross capacities and do not include evaporator coil blower motor heat deduction.

GCS24-3003 TOTAL COOLING CAPACITY (With All Compressors Operating)

Entering Wet Bulb Temperature	Total Air Volume		Outdoor Air Temperature Entering Condenser Coil																							
			85°F (29°C)			95°F (35°C)			105°F (41°C)			115°F (46°C)														
			Total Cooling Capacity		Compressor Motor Watts Input	Sensible To Total Ratio (S/T) Dry Bulb			Total Cooling Capacity		Compressor Motor Watts Input	Sensible To Total Ratio (S/T) Dry Bulb			Total Cooling Capacity		Compressor Motor Watts Input	Sensible To Total Ratio (S/T) Dry Bulb								
			L/s	cfm		kW	Btuh	75°F 24°C	80°F 27°C	85°F 29°C		kW	Btuh	75°F 24°C	80°F 27°C	85°F 29°C		kW	Btuh	75°F 24°C	80°F 27°C	85°F 29°C	kW	Btuh	75°F 24°C	80°F 27°C
63°F (17.2°C)	4010	8500	85.5	291,700	23,130	.70	.88	.99	81.7	278,900	24,680	.72	.90	1.00	77.9	265,900	26,200	.74	.93	1.00	73.9	252,300	27,650	.76	.96	1.00
	4720	10,000	87.9	300,000	23,460	.75	.94	1.00	84.1	287,200	25,070	.77	.96	1.00	80.4	274,400	26,660	.80	.98	1.00	76.5	261,200	28,220	.83	.99	1.00
	5425	11,500	90.1	307,600	23,760	.81	.98	1.00	86.6	295,400	25,450	.83	.99	1.00	82.8	282,600	27,110	.86	1.00	1.00	78.8	268,900	28,710	.89	1.00	1.00
67°F (19.4°C)	4010	8500	90.0	307,000	23,710	.54	.68	.84	86.0	293,400	25,360	.55	.69	.86	81.9	279,500	26,930	.56	.71	.89	77.4	264,300	28,420	.57	.73	.92
	4720	10,000	91.8	313,400	23,950	.57	.72	.91	87.7	299,400	25,630	.58	.74	.93	83.5	285,100	27,250	.59	.77	.96	79.1	269,800	28,760	.60	.80	.98
	5425	11,500	93.3	318,400	24,150	.59	.78	.96	89.2	304,600	25,850	.61	.80	.98	84.9	289,900	27,500	.62	.83	1.00	80.5	274,700	29,060	.64	.87	1.00
71°F (21.7°C)	4010	8500	95.4	325,700	24,400	.40	.53	.66	91.3	311,600	26,160	.40	.54	.67	87.0	296,800	27,850	.40	.55	.69	82.3	281,000	29,450	.41	.56	.71
	4720	10,000	97.0	331,100	24,620	.41	.55	.70	93.2	317,000	26,390	.41	.57	.72	88.4	301,600	28,110	.42	.58	.74	83.7	285,500	29,730	.42	.60	.78
	5425	11,500	98.4	335,700	24,750	.42	.58	.75	94.1	321,000	26,580	.42	.60	.78	89.5	305,500	28,320	.43	.61	.81	84.7	289,00				

BLOWER DATA

GCS24-953 BLOWER PERFORMANCE

Air Volume cfm (L/s)	STATIC PRESSURE EXTERNAL TO UNIT – Inches Water Gauge (Pa)																			
	.20 (50)		.40 (75)		.50 (125)		.70 (175)		.80 (200)		.90 (225)		1.00 (250)		1.10 (275)		1.30 (325)		1.50 (375)	
	RPM	BHP (kW)	RPM	BHP (kW)	RPM	BHP (kW)	RPM	BHP (kW)	RPM	BHP (kW)	RPM	BHP (kW)	RPM	BHP (kW)	RPM	BHP (kW)	RPM	BHP (kW)	RPM	BHP (kW)
2400 (1135)	-----	-----	-----	-----	810	0.85 (0.63)	905	1.05 (0.78)	955	1.15 (1.16)	1000	1.25 (0.93)	1050	1.40 (1.04)	1100	1.55 (1.16)	1195	1.95 (1.45)	1285	2.25 (1.68)
2600 (1225)	-----	-----	-----	-----	840	1.00 (0.75)	930	1.20 (0.90)	970	1.30 (0.97)	1015	1.40 (1.04)	1060	1.55 (1.16)	1105	1.70 (1.27)	1200	2.15 (1.60)	-----	-----
2800 (1320)	-----	-----	830	1.05 (0.78)	870	1.15 (0.86)	955	1.35 (1.00)	995	1.45 (1.08)	1035	1.60 (1.19)	1075	1.70 (1.27)	1115	1.85 (1.38)	1210	2.25 (3.78)	-----	-----
3000 (1415)	-----	-----	860	1.20 (0.90)	905	1.30 (0.97)	980	1.55 (1.16)	1020	1.65 (1.23)	1060	1.80 (1.34)	1095	1.90 (1.42)	1135	2.05 (1.53)	-----	-----	-----	-----
3200 (1510)	835	1.20 (0.90)	905	1.40 (1.04)	940	1.50 (1.12)	1010	1.75 (1.31)	1050	1.90 (1.42)	1085	2.00 (1.49)	-----	-----	-----	-----	-----	-----	-----	-----
3400 (1605)	880	1.40 (1.04)	945	1.60 (1.19)	980	1.75 (1.31)	1045	2.00 (1.49)	1080	2.10 (1.57)	-----	-----	-----	-----	-----	-----	-----	-----	-----	-----
3600 (1700)	920	1.65 (1.23)	985	1.85 (1.38)	1015	2.00 (1.49)	1080	2.25 (1.68)	-----	-----	-----	-----	-----	-----	-----	-----	-----	-----	-----	-----
3800 (1795)	965	1.90 (1.41)	1025	2.15 (1.60)	-----	-----	-----	-----	-----	-----	-----	-----	-----	-----	-----	-----	-----	-----	-----	-----

NOTE – All data is measured external to the unit with dry coil and with the air filters in place. See Page 21 for Accessory Air Resistance data.

NOTE – In Canada, maximum usable motor output is 2 hp (1.49 kW).

GCS24-1353 BLOWER PERFORMANCE

Air Volume cfm (L/s)	STATIC PRESSURE EXTERNAL TO UNIT – Inches Water Gauge (Pa)																			
	.20 (50)		.40 (75)		.50 (125)		.70 (175)		.80 (200)		.90 (225)		1.00 (250)		1.10 (275)		1.30 (325)		1.50 (375)	
	RPM	BHP (kW)	RPM	BHP (kW)	RPM	BHP (kW)	RPM	BHP (kW)	RPM	BHP (kW)	RPM	BHP (kW)	RPM	BHP (kW)	RPM	BHP (kW)	RPM	BHP (kW)	RPM	BHP (kW)
3600 (1700)	-----	-----	672	1.14 (0.85)	707	1.24 (0.93)	772	1.47 (1.10)	802	1.60 (1.19)	831	1.74 (1.30)	860	1.87 (1.40)	887	2.00 (1.49)	940	2.30 (1.72)	985	2.60 (1.94)
3800 (1795)	-----	-----	690	1.27 (0.95)	725	1.39 (1.04)	790	1.64 (1.22)	820	1.78 (1.33)	850	1.93 (1.44)	878	2.06 (1.54)	905	2.20 (1.64)	950	2.46 (1.84)	994	2.76 (2.06)
4000 (1890)	642	1.18 (0.88)	715	1.43 (1.07)	746	1.54 (1.15)	809	1.81 (1.35)	838	1.95 (1.45)	866	2.09 (1.56)	895	2.24 (1.67)	920	2.38 (1.78)	968	2.66 (1.98)	1013	2.96 (2.21)
4200 (1980)	670	1.35 (1.01)	736	1.50 (1.12)	768	1.73 (1.29)	828	2.00 (1.49)	856	2.13 (1.59)	885	2.28 (1.70)	913	2.43 (1.81)	938	2.56 (1.91)	984	2.86 (2.13)	1030	3.19 (2.38)
4400 (2075)	693	1.52 (1.13)	760	1.79 (1.34)	790	1.93 (1.44)	850	2.29 (1.71)	878	2.36 (1.76)	905	2.50 (1.87)	930	2.63 (1.96)	955	2.77 (2.07)	1003	3.08 (2.30)	-----	-----
4600 (2170)	718	1.70 (1.27)	785	2.00 (1.49)	815	2.15 (1.60)	872	2.44 (1.82)	900	2.59 (1.93)	923	2.71 (2.02)	948	2.84 (2.12)	974	3.00 (2.24)	1021	3.32 (2.48)	-----	-----
4800 (2265)	747	1.93 (1.44)	807	2.22 (1.66)	835	2.37 (1.60)	892	2.66 (1.98)	918	2.82 (2.10)	940	2.93 (2.19)	970	3.09 (2.31)	995	3.25 (2.42)	-----	-----	-----	-----
5000 (2360)	772	2.16 (1.61)	830	2.46 (1.84)	860	2.66 (2.06)	915	2.92 (2.18)	940	3.07 (2.29)	965	3.24 (2.42)	989	3.43 (2.56)	-----	-----	-----	-----	-----	-----
5200 (2455)	800	2.41 (1.80)	860	2.75 (2.05)	887	2.89 (2.16)	940	3.22 (2.40)	965	3.42 (2.55)	-----	-----	-----	-----	-----	-----	-----	-----	-----	-----

NOTE – All data is measured external to the unit with dry coil and with the air filters in place. See Page 21 for Accessory Air Resistance data.

NOTE – In Canada, maximum usable motor output is 3 hp (2.24 kW).

GCS24-1603 BLOWER PERFORMANCE

Air Volume cfm (L/s)	STATIC PRESSURE EXTERNAL TO UNIT — Inches Water Gauge (Pa)																					
	.20 (50)		.40 (75)		.50 (125)		.70 (175)		.80 (200)		.90 (225)		1.00 (250)		1.10 (275)		1.30 (325)		1.50 (375)			
	RPM	BHP (kW)	RPM	BHP (kW)	RPM	BHP (kW)	RPM	BHP (kW)	RPM	BHP (kW)	RPM	BHP (kW)	RPM	BHP (kW)	RPM	BHP (kW)	RPM	BHP (kW)	RPM	BHP (kW)	RPM	BHP (kW)
4200 (1980)	-----	-----	750	1.67 (1.25)	780	1.77 (1.32)	840	2.05 (1.53)	870	2.17 (1.62)	900	2.31 (1.72)	930	2.45 (1.83)	955	2.60 (2.07)	1010	2.90 (2.28)	1045	3.14 (2.34)		
4400 (2075)	710	1.59 (1.19)	770	1.83 (1.41)	805	1.99 (1.48)	860	2.24 (1.67)	890	2.39 (1.78)	915	2.51 (1.87)	945	2.67 (1.99)	970	2.83 (2.11)	1025	3.12 (2.33)	1060	3.39 (2.53)		
4600 (2170)	735	1.78 (1.33)	795	2.13 (1.59)	825	2.17 (1.62)	880	2.45 (1.83)	910	2.60 (1.94)	935	2.75 (2.05)	960	2.89 (2.16)	990	3.06 (2.39)	1040	3.38 (2.66)	1075	3.62 (2.70)		
4800 (2265)	760	2.00 (1.49)	820	2.27 (1.69)	850	2.43 (1.81)	905	2.70 (2.01)	930	2.85 (2.13)	955	3.01 (2.25)	980	3.26 (2.43)	1010	3.33 (2.48)	1055	3.63 (2.71)	1090	3.87 (2.89)		
5000 (2360)	790	2.26 (1.69)	845	2.53 (1.89)	875	2.68 (2.00)	925	2.96 (2.21)	950	3.11 (2.32)	975	3.27 (2.44)	1000	3.41 (2.54)	1025	3.58 (2.67)	1075	3.94 (2.94)	1110	4.16 (3.10)		
5200 (2455)	815	2.50 (1.87)	870	2.80 (2.09)	900	2.95 (2.20)	950	3.25 (2.42)	975	3.42 (2.55)	1000	3.56 (2.66)	1025	3.75 (2.80)	1045	3.88 (2.89)	1095	4.23 (3.16)	1125	4.46 (3.33)		
5400 (2550)	840	2.79 (2.08)	895	3.07 (2.29)	920	3.24 (2.42)	970	3.55 (2.65)	995	3.70 (2.76)	1020	3.87 (2.89)	1045	4.09 (3.05)	1070	4.22 (3.15)	1110	4.53 (3.38)	1145	4.81 (3.59)		
5600 (2645)	865	3.08 (2.30)	920	3.39 (2.53)	950	3.58 (2.67)	995	3.88 (2.89)	1020	4.05 (3.02)	1045	4.22 (3.15)	1065	4.37 (3.26)	1090	4.57 (3.41)	1130	4.89 (3.65)	1165	5.16 (3.85)		
5800 (2735)	895	3.38 (2.52)	945	3.73 (2.78)	980	3.90 (2.91)	1020	4.25 (3.17)	1045	4.42 (3.30)	1065	4.57 (3.41)	1090	4.76 (3.55)	1110	4.93 (3.68)	1150	5.25 (3.92)	1185	5.59 (4.17)		

NOTE — All data is measured external to the unit with dry coil and with the air filters in place. See Page 21 for Accessory Air Resistance data.

NOTE — Data in shaded area requires field furnished motor and drive.

NOTE — In Canada, maximum usable motor output is 3 hp (2.24 kW).

BLOWER DATA — GCS24-3003-235

Air Volume cfm (L/s)	STATIC PRESSURE EXTERNAL TO UNIT — Inches Water Gauge (Pa)																		
	.30 (75)	.40 (100)	.50 (125)	.60 (150)	.70 (175)	.80 (200)	.90 (225)	1.00 (250)	1.10 (275)	1.20 (300)	1.30 (325)	1.40 (350)	1.50 (375)	1.60 (400)	1.70 (425)	1.80 (450)	1.90 (470)	2.00 (495)	
	RPM BHP (kW)	RPM BHP (kW)	RPM BHP (kW)	RPM BHP (kW)	RPM BHP (kW)	RPM BHP (kW)	RPM BHP (kW)	RPM BHP (kW)	RPM BHP (kW)	RPM BHP (kW)	RPM BHP (kW)	RPM BHP (kW)	RPM BHP (kW)	RPM BHP (kW)	RPM BHP (kW)	RPM BHP (kW)	RPM BHP (kW)	RPM BHP (kW)	RPM BHP (kW)
9000 (4245)	----	----	----	----	----	----	----	----	----	----	----	----	----	----	----	----	860 7.65 (5.70)	875 7.90 (5.89)	
9250 (4365)	----	----	----	----	----	----	----	----	----	----	----	----	----	----	----	855 7.80 (5.81)	865 7.95 (5.93)	880 8.25 (6.15)	
9500 (4485)	----	----	----	----	----	----	----	----	----	----	----	----	----	830 7.65 (5.70)	845 7.90 (5.89)	860 8.15 (6.07)	875 8.40 (6.26)	890 8.65 (6.45)	
9750 (4600)	----	----	----	----	----	----	----	----	----	----	810 7.55 (5.63)	825 7.80 (5.81)	840 8.05 (6.00)	855 8.30 (6.19)	870 8.60 (6.41)	885 8.85 (6.60)	900 9.10 (6.78)		
10,000 (4720)	----	----	----	----	----	----	----	----	----	805 7.70 (5.74)	820 7.95 (5.93)	835 8.20 (6.11)	850 8.50 (6.34)	865 8.75 (6.52)	880 9.00 (6.71)	895 9.30 (6.93)	910 9.60 (7.16)		
10,250 (4835)	----	----	----	----	----	----	----	785 7.70 (5.74)	805 7.85 (5.85)	820 8.20 (6.11)	835 8.35 (6.22)	850 8.80 (6.56)	860 9.00 (6.71)	875 9.30 (6.93)	895 9.60 (7.16)	905 9.80 (7.31)	920 10.10 (7.53)		
10,500 (4955)	----	----	----	----	----	765 7.60 (5.66)	780 7.90 (5.89)	800 8.20 (6.11)	810 8.35 (6.22)	835 8.85 (6.60)	845 9.00 (6.71)	860 9.25 (6.90)	875 9.80 (7.31)	890 9.90 (7.38)	905 10.15 (7.57)	950 10.50 (7.83)	930 10.75 (8.01)		
10,750 (5075)	----	----	----	750 7.65 (5.70)	760 7.75 (5.78)	775 8.05 (6.00)	795 8.50 (6.34)	810 8.70 (6.49)	825 9.00 (6.71)	845 9.35 (6.97)	855 9.60 (7.16)	875 9.95 (7.42)	885 10.20 (7.60)	900 10.50 (7.83)	915 10.80 (8.05)	930 11.20 (8.35)	940 11.50 (8.57)		
11,000 (5190)	----	----	730 7.70 (5.74)	745 7.80 (5.81)	760 8.10 (6.04)	775 8.35 (6.22)	790 8.65 (6.45)	805 8.95 (6.67)	825 9.25 (6.90)	840 9.60 (7.16)	855 9.85 (7.34)	865 10.25 (7.64)	885 10.50 (7.83)	895 10.80 (8.09)	910 11.10 (8.28)	925 11.50 (8.57)	----	----	
11,250 (5310)	710 7.75 (5.78)	730 7.65 (5.70)	745 8.10 (6.04)	755 8.30 (6.19)	770 8.50 (6.34)	785 8.80 (6.56)	805 9.20 (6.86)	820 9.45 (6.30)	840 10.00 (7.46)	850 10.10 (7.53)	865 10.40 (7.75)	880 10.70 (7.98)	895 11.15 (8.31)	910 11.45 (8.54)	----	----	----	----	
11,500 (5425)	730 8.10 (6.04)	745 8.40 (6.26)	755 8.55 (6.37)	775 8.80 (6.56)	785 9.00 (6.71)	805 9.50 (7.08)	820 9.80 (7.31)	840 10.30 (7.68)	850 10.45 (7.79)	860 10.60 (7.90)	875 11.00 (8.20)	890 11.45 (8.50)	----	----	----	----	----	----	
11,750 (5545)	745 8.60 (6.41)	755 8.80 (6.56)	770 9.00 (6.71)	785 9.25 (6.90)	800 9.70 (7.23)	815 10.00 (7.46)	840 10.50 (7.80)	850 10.75 (8.01)	860 10.90 (8.13)	875 11.35 (8.46)	----	----	----	----	----	----	----	----	
12,000 (5665)	755 9.05 (6.75)	775 9.35 (6.97)	785 9.65 (7.19)	800 10.00 (7.46)	810 10.15 (7.57)	830 10.70 (7.98)	850 11.05 (8.24)	860 11.30 (8.42)	875 11.50 (8.57)	----	----	----	----	----	----	----	----	----	
12,250 (5780)	775 9.70 (7.23)	790 10.05 (7.49)	800 10.30 (7.68)	810 10.50 (7.83)	830 10.85 (8.09)	845 11.30 (8.42)	860 11.50 (8.57)	----	----	----	----	----	----	----	----	----	----	----	
12,500 (5900)	790 10.40 (7.75)	800 10.55 (7.87)	810 11.00 (8.20)	840 11.00 (8.20)	850 11.50 (8.57)	----	----	----	----	----	----	----	----	----	----	----	----	----	

NOTE — All data is measured external to the unit with dry coil and air filters in place. See Page 21 for Accessory Air Resistance data.

NOTE — Maximum air volume for GCS24-3003 is 12,500 cfm (5900 L/s).

Shaded area denotes optional 10 hp (7460W) drive kit for GCS24-3003 unit.

NOTE — In Canada, nominal motor output is also maximum usable motor output.

BLOWER DATA — GCS24-3003-470

Air Volume cfm (L/s)	STATIC PRESSURE EXTERNAL TO UNIT — Inches Water Gauge (Pa)																	
	.30 (75)	.40 (100)	.50 (125)	.60 (150)	.70 (175)	.80 (200)	.90 (225)	1.00 (250)	1.10 (275)	1.20 (300)	1.30 (325)	1.40 (350)	1.50 (375)	1.60 (400)	1.70 (425)	1.80 (450)	1.90 (470)	2.00 (495)
	RPM BHP (kW)	RPM BHP (kW)	RPM BHP (kW)	RPM BHP (kW)	RPM BHP (kW)	RPM BHP (kW)	RPM BHP (kW)	RPM BHP (kW)	RPM BHP (kW)	RPM BHP (kW)	RPM BHP (kW)	RPM BHP (kW)	RPM BHP (kW)	RPM BHP (kW)	RPM BHP (kW)	RPM BHP (kW)	RPM BHP (kW)	RPM BHP (kW)
8500 (4010)	----	----	----	----	----	----	----	----	----	----	----	----	----	----	----	----	----	870 7.50 (5.60)
8750 (4130)	----	----	----	----	----	----	----	----	----	----	----	----	----	----	----	----	860 7.50 (5.60)	870 7.80 (5.81)
9000 (4245)	----	----	----	----	----	----	----	----	----	----	----	----	----	----	----	855 8.05 (6.00)	870 7.90 (5.89)	885 8.20 (6.11)
9250 (4365)	----	----	----	----	----	----	----	----	----	----	----	----	----	----	850 7.80 (5.81)	865 8.05 (6.00)	880 8.35 (6.22)	890 8.50 (6.34)
9500 (4485)	----	----	----	----	----	----	----	----	----	----	----	----	825 7.60 (5.66)	840 7.85 (5.85)	855 8.10 (6.04)	870 8.40 (6.26)	885 8.65 (6.45)	900 8.95 (6.67)
9750 (4600)	----	----	----	----	----	----	----	----	----	----	805 7.50 (5.60)	820 7.75 (5.78)	835 8.00 (5.96)	850 8.25 (6.15)	865 8.55 (6.37)	880 8.80 (6.56)	895 9.10 (6.78)	910 9.40 (7.01)
10,000 (4720)	----	----	----	----	----	----	----	----	----	800 7.65 (5.70)	815 7.90 (5.89)	830 8.15 (6.07)	845 8.40 (6.26)	860 8.70 (6.49)	875 8.95 (6.67)	890 9.25 (6.90)	905 9.55 (7.12)	920 9.85 (7.34)
10,250 (4835)	----	----	----	----	----	----	----	795 7.80 (5.81)	810 8.05 (6.00)	825 8.30 (6.19)	840 8.55 (6.37)	855 8.85 (6.60)	870 9.15 (6.82)	885 9.40 (7.01)	900 9.70 (7.23)	915 10.05 (7.49)	925 10.25 (7.64)	
10,500 (4955)	----	----	----	----	----	770 7.60 (5.66)	790 7.95 (5.93)	805 8.20 (6.11)	820 8.45 (6.30)	835 8.75 (6.52)	850 9.00 (6.71)	865 9.30 (6.93)	880 9.50 (7.80)	895 9.90 (7.38)	910 10.20 (7.60)	920 10.40 (7.75)	935 10.75 (8.01)	
10,750 (5075)	----	----	----	750 7.55 (5.63)	765 7.80 (5.81)	785 8.10 (6.04)	800 8.40 (6.26)	815 8.65 (6.45)	830 8.90 (6.63)	845 9.20 (6.86)	860 9.50 (7.08)	875 9.75 (7.27)	890 10.05 (7.49)	905 10.40 (7.75)	920 10.70 (7.98)	930 10.90 (8.13)	945 11.25 (8.39)	
11,000 (5190)	----	----	745 7.70 (5.74)	765 8.05 (6.00)	780 8.30 (6.19)	795 8.55 (6.37)	810 8.80 (6.56)	825 9.10 (6.78)	840 9.35 (6.97)	855 9.65 (7.19)	870 9.95 (7.42)	885 10.25 (7.64)	900 10.55 (7.87)	915 10.90 (8.13)	930 11.20 (8.35)	940 11.45 (8.54)	----	
11,250 (5310)	----	725 7.65 (5.70)	745 7.95 (5.93)	760 8.20 (6.11)	775 8.45 (6.30)	790 8.75 (6.52)	805 9.00 (6.71)	820 9.30 (6.93)	835 9.65 (7.19)	855 9.95 (7.42)	865 10.15 (7.57)	880 10.45 (7.79)	895 10.75 (8.01)	910 11.10 (8.28)	925 11.40 (8.50)	----	----	----
11,500 (5425)	720 7.80 (5.81)	740 8.15 (6.07)	755 8.40 (6.26)	770 8.65 (6.45)	790 9.00 (6.71)	805 9.30 (6.93)	820 9.55 (7.12)	835 9.85 (7.34)	850 10.15 (7.57)	865 10.45 (7.79)	880 10.75 (8.01)	890 10.95 (8.16)	905 11.30 (8.42)	----	----	----	----	----
11,750 (5545)	735 8.35 (6.22)	750 8.60 (6.41)	770 8.95 (6.67)	785 9.20 (6.86)	800 9.45 (7.04)	815 9.75 (7.25)	830 10.05 (7.49)	845 10.35 (7.72)	860 10.65 (7.94)	875 10.95 (8.16)	890 11.25 (8.39)	----	----	----	----	----	----	----
12,000 (5665)	750 8.85 (6.60)	765 9.10 (6.78)	780 9.40 (7.01)	795 9.65 (7.19)	810 9.95 (7.42)	830 10.35 (7.72)	845 10.65 (7.94)	855 10.85 (8.09)	870 11.15 (8.31)	885 11.50 (8.57)	----	----	----	----	----	----	----	----
12,250 (5780)	765 9.40 (7.01)	780 9.70 (7.23)	795 9.95 (7.42)	810 10.25 (7.64)	825 10.55 (7.87)	840 10.85 (8.09)	855 11.15 (8.31)	870 11.50 (8.57)	----	----	----	----	----	----	----	----	----	----
12,500 (5900)	775 9.90 (7.39)	790 10.20 (7.61)	810 10.55 (7.87)	825 10.85 (8.09)	840 11.20 (6.27)	850 11.40 (8.50)	----	----	----	----	----	----	----	----	----	----	----	----

NOTE — All data is measured external to the unit with dry coil and air filters in place. See Page 21 for Accessory Air Resistance data.

NOTE — Maximum air volume for GCS24-3003 is 12,500 cfm (5900 L/s).

Shaded area denotes optional 10 hp (7460W) drive kit for GCS24-3003 unit.

NOTE — In Canada, nominal motor output is also maximum usable motor output.

BLOWER DATA

ACCESSORY AIR RESISTANCE

Unit Model No.	Air Volume		Total Resistance – inches water gauge (Pa)						
			Wet Evaporator Coil	REMD Down-Flow Economizer	EMDH16M Horizontal Economizer	RTD11 Step-Down Diffuser			FD11 Flush Diffuser
	cfm	L/s				2 Ends Open	1 Side 2 Ends Open	All Ends & Sides Open	
GCS24-953	2400	1185	.12 (30)	.25 (62)	.03 (7)	.21 (52)	.18 (45)	.15 (37)	.14 (35)
	2600	1225	.13 (32)	.31 (77)	.04 (10)	.24 (60)	.21 (52)	.18 (45)	.17 (42)
	2800	1320	.14 (35)	.37 (92)	.04 (10)	.27 (67)	.24 (60)	.21 (52)	.20 (50)
	3000	1415	.16 (40)	.43 (107)	.05 (12)	.32 (80)	.29 (72)	.25 (62)	.25 (62)
	3200	1510	.18 (45)	.50 (124)	.05 (12)	.41 (102)	.37 (92)	.32 (80)	.31 (77)
	3400	1605	.19 (47)	.53 (132)	.06 (15)	.50 (124)	.45 (112)	.39 (97)	.37 (92)
	3600	1700	.21 (52)	.55 (137)	.06 (15)	.61 (152)	.54 (134)	.48 (119)	.44 (109)
GCS24-1353	3800	1795	.23 (57)	.60 (149)	.07 (17)	.73 (182)	.63 (157)	.57 (142)	.51 (127)
	3600	1700	.12 (30)	.18 (45)	.03 (7)	.36 (90)	.28 (70)	.23 (57)	.15 (37)
	3800	1795	.13 (32)	.19 (47)	.04 (10)	.40 (99)	.32 (80)	.26 (65)	.18 (45)
	4000	1890	.14 (35)	.21 (52)	.04 (10)	.44 (109)	.36 (90)	.29 (72)	.21 (52)
	4200	1980	.15 (37)	.24 (60)	.05 (12)	.49 (122)	.40 (99)	.33 (82)	.24 (60)
	4400	2075	.16 (40)	.26 (65)	.05 (12)	.54 (134)	.44 (109)	.37 (92)	.27 (67)
	4600	2170	.17 (42)	.28 (70)	.06 (15)	.60 (149)	.49 (122)	.42 (104)	.31 (77)
	4800	2265	.18 (45)	.30 (75)	.07 (17)	.65 (162)	.53 (132)	.46 (114)	.35 (87)
GCS24-1603	5000	2360	.19 (47)	.31 (77)	.09 (22)	.69 (172)	.58 (144)	.50 (124)	.39 (97)
	5200	2455	.20 (50)	.32 (80)	.10 (25)	.75 (186)	.62 (154)	.54 (134)	.43 (107)
	4200	1980	.10 (25)	.18 (45)	.06 (15)	.22 (55)	.19 (47)	.16 (40)	.10 (25)
	4400	2075	.11 (27)	.20 (50)	.07 (17)	.28 (70)	.24 (60)	.20 (50)	.12 (30)
	4600	2170	.12 (30)	.21 (52)	.07 (17)	.34 (85)	.29 (72)	.24 (60)	.15 (37)
	4800	2265	.13 (32)	.23 (57)	.08 (20)	.40 (99)	.34 (85)	.29 (72)	.19 (47)
	5000	2360	.14 (35)	.26 (65)	.08 (20)	.46 (114)	.39 (97)	.34 (85)	.23 (57)
	5200	2455	.15 (37)	.31 (77)	.09 (22)	.52 (129)	.44 (109)	.39 (97)	.27 (67)
GCS24-3003	5400	2550	.16 (40)	.34 (85)	.10 (25)	.58 (144)	.49 (122)	.43 (107)	.31 (77)
	5600	2645	.17 (42)	.38 (94)	.12 (30)	.64 (159)	.54 (134)	.47 (117)	.35 (87)
	5800	2735	.18 (45)	.40 (99)	.13 (32)	.70 (174)	.59 (147)	.51 (127)	.39 (97)
	6000	2830	.06 (15)	.01 (2)	----	.36 (90)	.31 (77)	.27 (67)	.29 (72)
	6500	3065	.07 (17)	.02 (5)	----	.42 (104)	.36 (90)	.31 (77)	.34 (85)
	7000	3305	.08 (20)	.02 (5)	----	.49 (122)	.41 (102)	.36 (90)	.40 (99)
	7500	3540	.09 (22)	.04 (10)	----	.51 (127)	.46 (114)	.41 (102)	.45 (112)
	8000	3775	.10 (25)	.06 (15)	----	.59 (147)	.49 (122)	.43 (107)	.50 (124)
GCS24-953	8500	4010	.11 (27)	.08 (20)	----	.69 (172)	.58 (144)	.50 (124)	.57 (142)
	9000	4245	.12 (30)	.10 (25)	----	.79 (196)	.67 (167)	.58 (144)	.66 (164)
	9500	4485	.13 (32)	.12 (30)	----	.89 (221)	.75 (186)	.65 (162)	.74 (184)
	10,000	4720	.15 (37)	.14 (35)	----	1.00 (249)	.84 (209)	.73 (182)	.81 (201)

CEILING DIFFUSER AIR THROW DATA

Model No.	Air Volume		*Effective Throw Range			
			RTD11 Step-Down		FD11 Flush	
	cfm	L/s	ft.	m	ft.	m
GCS24-953	3000	1415	27 – 33	8 – 10	25 – 30	8 – 9
	3375	1595	30 – 37	9 – 11	28 – 34	9 – 10
	3750	1770	34 – 41	10 – 12	31 – 38	9 – 12
GCS24-1353	4400	2075	34 – 42	10 – 13	32 – 40	10 – 12
	4950	2335	38 – 47	12 – 14	36 – 45	11 – 14
	5500	2595	43 – 52	13 – 16	40 – 50	12 – 15
GCS24-1603	4200	1980	39 – 46	12 – 14	40 – 48	12 – 15
	5000	2360	41 – 50	12 – 15	43 – 52	13 – 16
	5800	2735	43 – 52	13 – 16	45 – 54	14 – 16
GCS24-3003	8000	3775	39 – 44	12 – 13	53 – 62	16 – 19
	9000	4245	47 – 56	14 – 17	55 – 64	17 – 20
	10,000	4720	49 – 58	15 – 18	57 – 67	17 – 20

*Throw is the horizontal or vertical distance an airstream travels on leaving the outlet or diffuser before the maximum velocity is reduced to 50 ft. (15 m) per minute. Four sides open.

PED16-300 POWER EXHAUST FANS PERFORMANCE

Model No.	Air Volume Exhausted		Return Air System Static Pressure Inches Water Gauge (Pa)
	cfm	L/s	
PED16-300	6300	2970	0 (0)
	5750	2715	.05 (12)
	5200	2455	.10 (25)
	4625	2180	.15 (37)
	4050	1910	.20 (50)

GUIDE SPECIFICATIONS

Prepared for the guidance of architects, consulting engineers and mechanical contractors.

General — Furnish and install a single package combination air to air DX mechanical cooling system and gas fired heating system, complete with automatic controls. The single package unit shall be a standard product of a firm regularly engaged in the manufacture of heating-cooling equipment. The manufacturer shall have parts and service available throughout the U.S. and Canada.

The installed weight shall not be more than lbs. (kg) Entire unit shall have a width of not more than inches (mm), a depth of not more than inches (mm) and an overall height of not more than inches (mm). The equipment shall be shipped completely factory assembled, precharged, piped and wired internally ready for field connections. In addition, manufacturer shall test operate system at the factory before shipment.

Air Distribution — Equipment shall be capable of bottom (down-flo) or side (horizontal) handling of conditioned air. All air distribution ducts shall be fiberglass or ga. galvanized steel insulated with inch (mm) thick lb./ft.³ (kg/m³) density fiberglass or equivalent.

Approvals — All electrical components shall have U.L. and C.S.A. Listing. All wiring shall be in compliance with NEC and CEC.

Equipment Warranty — Heat exchangers shall have a limited warranty for a full ten years. Compressors have a limited warranty for a full five years. All other components have a limited warranty for one year. Refer to the Lennox Equipment Limited Warranty certificate included with the unit for details.

Cooling System — The total certified cooling capacity shall not be less than Btuh (kW) with an evaporator air volume of cfm (L/s), an entering wet bulb air temperature of °F (°C), an entering dry bulb air temperature of °F (°C) and a condenser entering temperature of °F (°C). The compressor power input shall not exceed kW at these conditions.

The coils shall be non-ferrous construction with aluminum fins mechanically bonded to durable copper tubes. Coils shall be pressure leak tested. Coil face area shall be not less than sq. ft. (m²) (evaporator) and sq. ft. (m²) (condenser). GCS24-953 condenser coil shall be formed coil construction. GCS24-1353-1603-3003 condenser coil shall be slab coil construction.

Compressors shall be resiliently mounted, have overload protection and crankcase heaters. GCS24-1353 shall have scroll compressor. The refrigeration system shall have suction and liquid line service gauge ports, high pressure switches, low pressure switches, thermometer wells, driers, freestat and full refrigerant charge. GCS24-1353-1603-3003 shall have low ambient controls. Control option available shall consist of low ambient controls (GCS24-953) and timed-off control (all models). Shall be rated in accordance with ARI Standard 210/240-89 or 360-86.

Heating System — The heating capacity output shall be Btuh (kW) with a gas input of Btuh (kW).

Tubular heat exchanger and inshot type gas burners shall be constructed of aluminized steel. Controls shall consist of direct spark ignition, electronic flame sensor controls, flame rollout switch, limit controls and automatic redundant dual gas valve with staging control and centrifugal switch on induced draft blower. Unit shall be available for use with LPG/propane as an option. Complete service access shall be provided for controls and wiring. Shall be A.G.A./C.G.A. design certified for outdoor installation.

Cabinet — Shall be galvanized steel with a powdered enamel paint finish electrostatically bonded to the metal. Cabinet panels where conditioned air is handled shall be fully insulated to prevent sweating and minimize sound. Openings shall be provided for power connection entry. Shall have peep hole with cover for flame viewing of burners. Evaporator coil condensate drain extended outside cabinet shall be provided. Lifting brackets shall be provided for rigging. Bottom power entry shall be furnished on GCS24-1603-3003 (optional for GCS24-953 & -1353). Control box panel shall be hinged for easy access on GCS24-1353-1603-3003. (optional for GCS24-953).

Service Access — All components, wiring and inspection areas shall be completely accessible through removable panels.

Supply Air Blowers — Centrifugal supply air blower shall have permanently lubricated sleeve bearings and adjustable belt drive. Motor mount base shall permit ease of motor changeover and belt tension adjustment. Blower wheel shall be statically and dynamically balanced with ball bearings. Blower shall be capable of delivering cfm (L/s) at an external static pressure of inches water gauge (Pa) requiring bhp (W) and rpm.

Condenser Fan(s) — Direct drive propeller type condenser fan(s) shall discharge vertically and be direct driven by a hp (W) motor. Fan motor shall have ball bearings and be permanently lubricated and inherently protected. Fan(s) shall have a safety guard.

Air Filters — Disposable filters furnished shall have not less than sq. ft. (m²) of free area.

OPTIONAL ACCESSORIES

Roof Mounting Frame — Furnish and install a steel roof mounting frame for bottom discharge and return air duct connection. It shall mate to the bottom perimeter of the equipment. When flashed into the roof it shall make a unit mounting curb and provide weatherproof duct connection and entry into the conditioned area. Flashing shall be the responsibility of a roofing contractor. RMF16 frame shall be approved by U.S. National Roofing Contractors Association.

Economizer Damper Section — Furnish and install complete with recirculated air dampers, outside air dampers, air filters, damper actuator and controls. Low leakage dampers shall ride in nylon bearings. Down-flow economizer shall have gravity exhaust. The economizer section shall provide for the introduction of 100% outdoor air for minimum ventilation and free cooling. Integrated economizer cycle shall allow compressors to cycle for dehumidification and additional cooling, as needed, with 100% outdoor air intake. Damper actuator shall be 24 volt, fully modulating spring return. Controls shall include fixed 55°F (13°C) mixed air controller, damper actuator, adjustable minimum position switch and solid-state adjustable outdoor air enthalpy control. Cabinet shall be galvanized steel with a powdered enamel paint finish electrostatically bonded to the metal. Control option shall consist of differential enthalpy control (return air sensor). Down-flow economizer shall be available for factory or field installation.

Gravity Exhaust Dampers — Optional pressure operated dampers shall be available for field installation in EMDH16 horizontal economizer damper section. Neoprene coated fiberglass dampers shall prevent blow-back and outdoor air infiltration during off cycle. Shall be equipped with rainhoods and bird screen. Shall be furnished with down-flow economizer. Shall be furnish with REMD16-300.

Outdoor Air Damper Section — Optional outdoor dampers shall be available to provide outdoor air requirements of up to 25%. Shall be available for manual or automatic operation. Damper section field installs external to the unit. Shall be equipped with filter for extra air filtering and bird screen protection.

Horizontal Supply & Return Air Kit — Optional kit shall provide necessary cabinet parts to field convert unit for side (horizontal) supply and return air duct connections.

Ceiling Diffusers — Furnish and install a (flush or stepdown) optional combination ceiling supply and return air diffuser. It shall be capable of not less than ft. (m) radius of effective throw. Supply and return transitions shall be available, for field installation in the roof mounting frame, to provide duct connection to the diffuser.

Control Systems — Shall provide a selection of thermostats and related controls to automatically operate the mechanical equipment through the heating or cooling and ventilating cycles as required.

Disconnect Package — Furnish and factory install package that includes unit disconnect, dual 120 volt GFCI type service outlets, bottom power entry (GCS24-953 & -1353 only), low ambient controls (GCS24-953 only) and hinged control box panel (GCS24-953 only).

Smoke Detector Package — Furnish and factory install photoelectric type smoke detector in return air section.

Corrosion Protection Package — Furnish and factory apply phenolic epoxy coating to condenser and evaporator coils with painted condensing and evaporator base sections and painted blower housings or apply only to condenser coil with painted condensing section base.

Logic Controls Package — Furnish and factory install a selection of controls to automatically operate the mechanical equipment through the heating or cooling and ventilating cycles as required.

Hinged Panel Package — Furnish and factory install package that includes hinged panels for two compressor section panels, two blower section panels and one electric heat access panel with quarter turn handles. GCS24-3003 only.

UNIT DIMENSIONS – inches (mm)

GCS24-953 BASIC UNIT

CORNER WEIGHTS – lbs. (kg)

Model Number	AA		BB		CC		DD	
	lbs.	kg	lbs.	kg	lbs.	kg	lbs.	kg
GCS24-953	236	107	283	128	194	88	162	69

CENTER OF GRAVITY – inches (mm)

Model Number	EE		FF	
	inch	mm	inch	mm
GCS24-953	28-1/2	724	40	1016

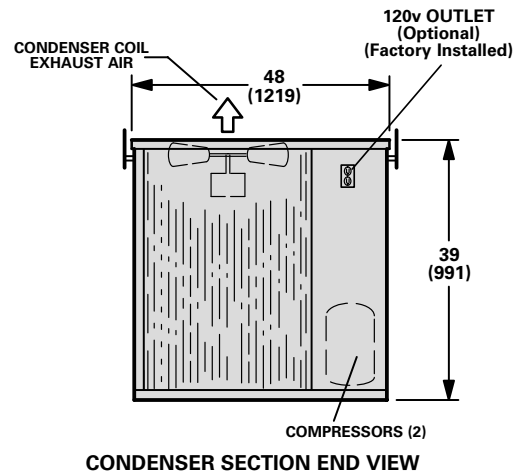
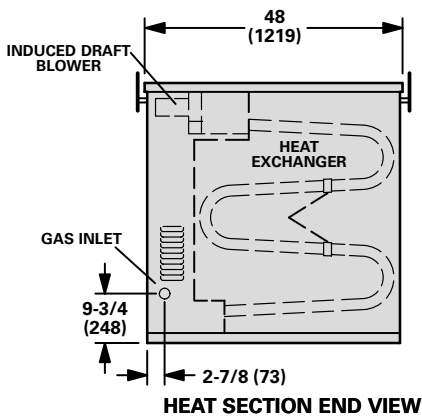
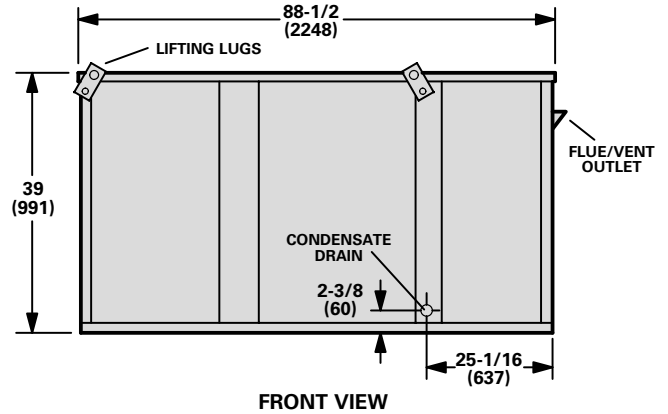
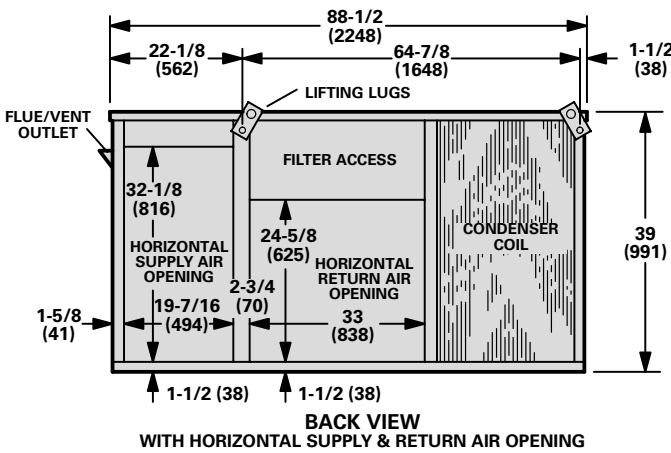
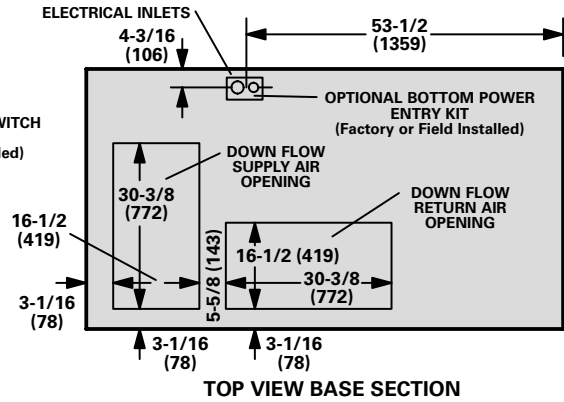
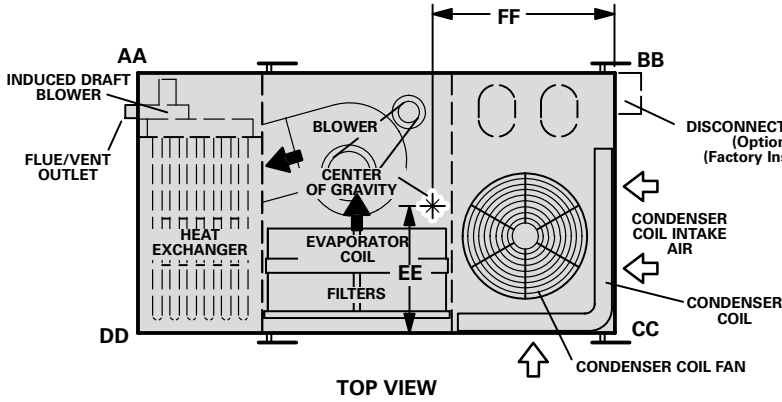

ACCESSORY DIMENSIONS – inches (mm)

**GCS24-953 UNIT WITH REMD24M-95 ECONOMIZER DAMPER SECTION
AND RMF16-95 ROOF MOUNTING FRAME**

CORNER WEIGHTS – lbs. (kg)

Model Number	AA		BB		CC		DD	
	lbs.	kg	lbs.	kg	lbs.	kg	lbs.	kg
GCS24-953	268	122	318	144	247	112	208	94

CENTER OF GRAVITY – inches (mm)

Model Number	EE		FF	
	inch	mm	inch	mm
GCS24-953	27	686	40-1/2	1029

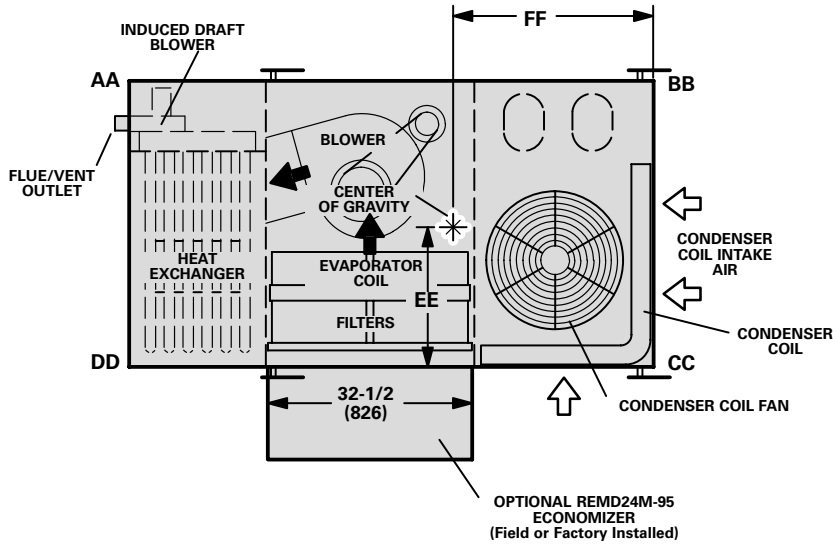

TOP VIEW

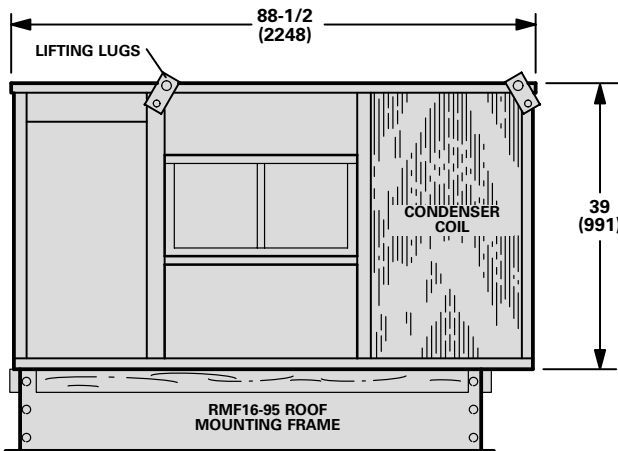

BACK VIEW

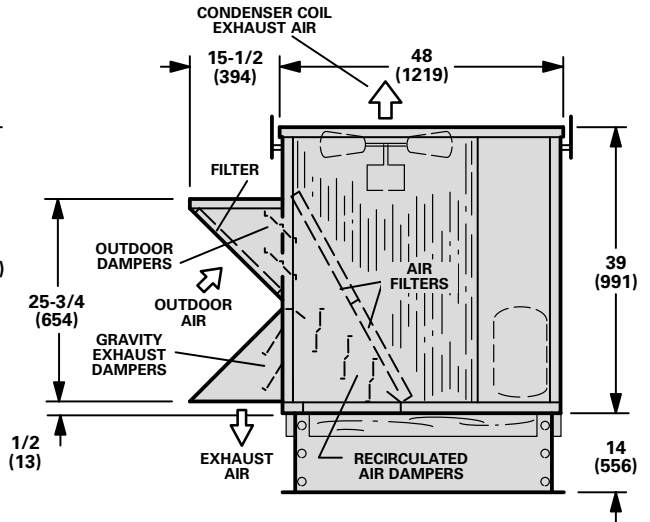

CONDENSER SECTION END VIEW

ACCESSORY DIMENSIONS – inches (mm)

**GCS24-953 UNIT WITH
EMDH16M-95 HORIZONTAL ECONOMIZER DAMPER SECTION**

CORNER WEIGHTS – lbs. (kg)

Model Number	AA		BB		CC		DD	
	lbs.	kg	lbs.	kg	lbs.	kg	lbs.	kg
GCS24-953	235	107	273	124	261	118	226	103

CENTER OF GRAVITY – inches (mm)

Model Number	EE		FF	
	inch	mm	inch	mm
GCS24-953	24-1/2	622	41	1041

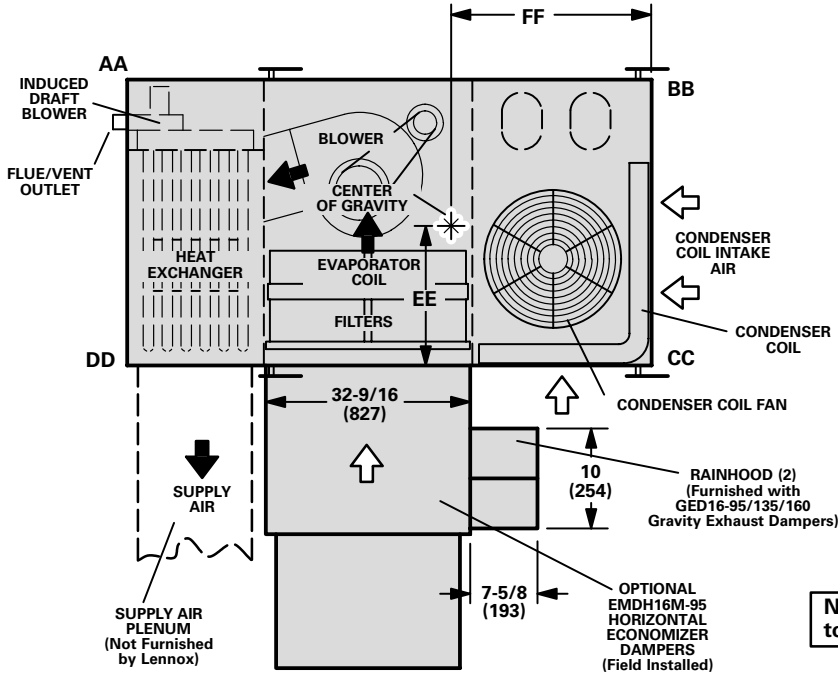

TOP VIEW

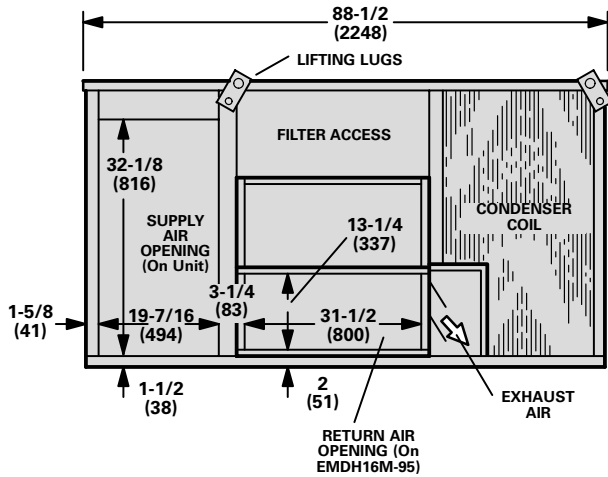

BACK VIEW

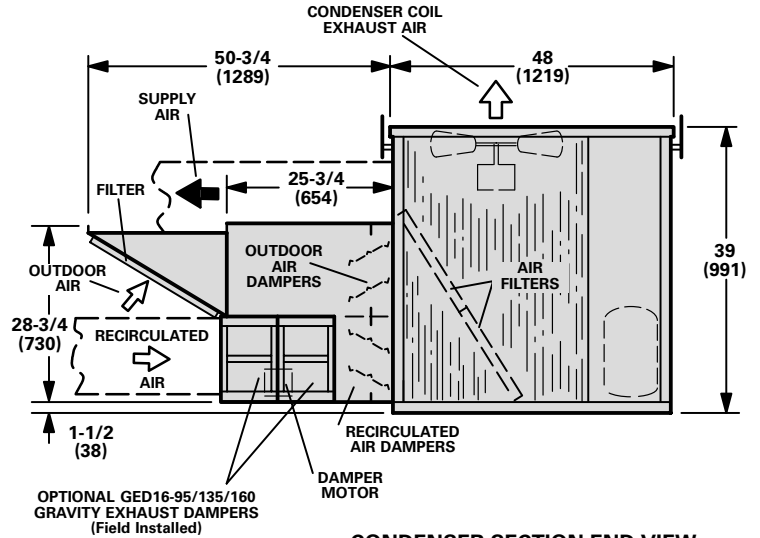

CONDENSER SECTION END VIEW

UNIT DIMENSIONS — inches (mm)

GCS24-1353 & 1603 BASIC UNITS

CORNER WEIGHTS — lbs. (kg)

Model No.	AA		BB		CC		DD	
	lbs.	kg	lbs.	kg	lbs.	kg	lbs.	kg
GCS24-1353	308	140	371	168	314	142	261	118
GCS24-1603	315	143	394	179	336	152	269	122

CENTER OF GRAVITY — in. (mm)

Model No.	EE		FF	
	in.	mm	in.	mm
GCS24-1353	32-1/2	826	44-1/2	1130
GCS24-1603	32-3/8	822	47-1/8	1197

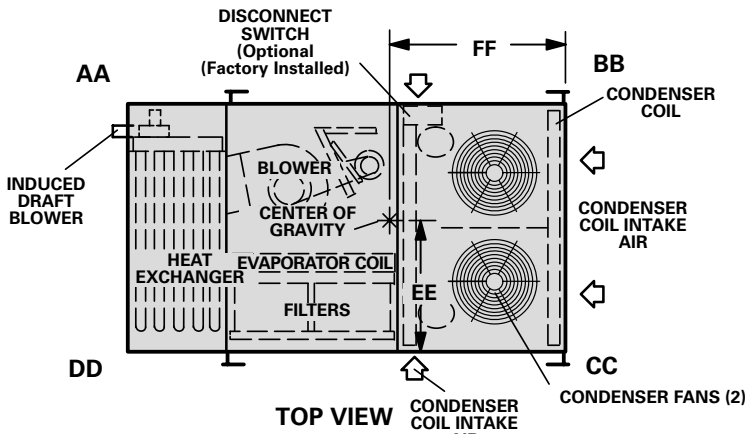

*NOTE — Bottom Power Entry Optional on GCS24-1353 Models
Furnished on GCS24-1603 Models

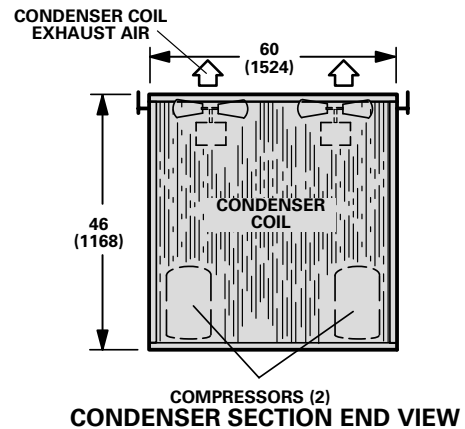
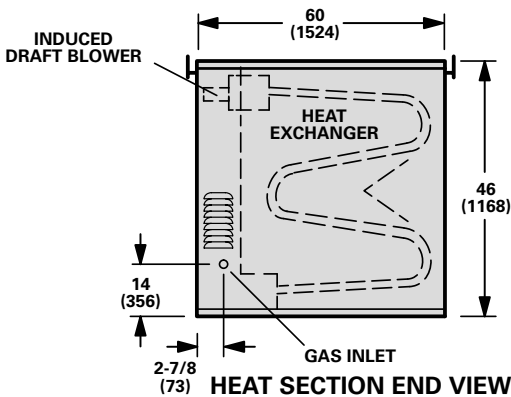
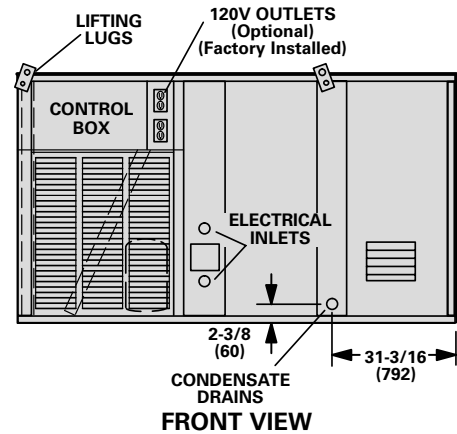
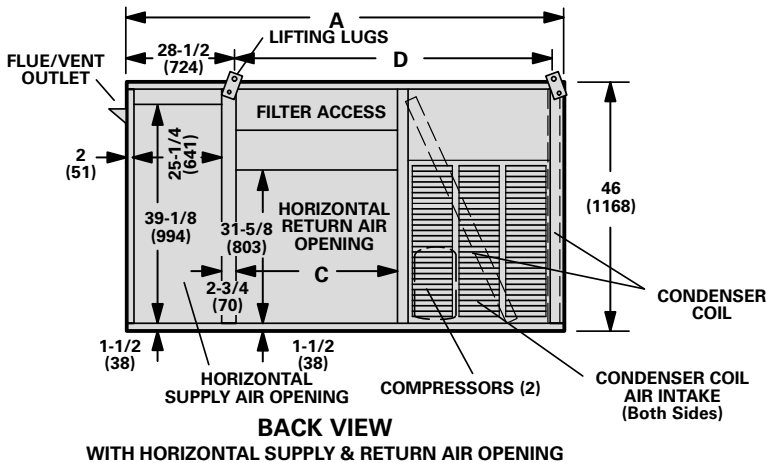
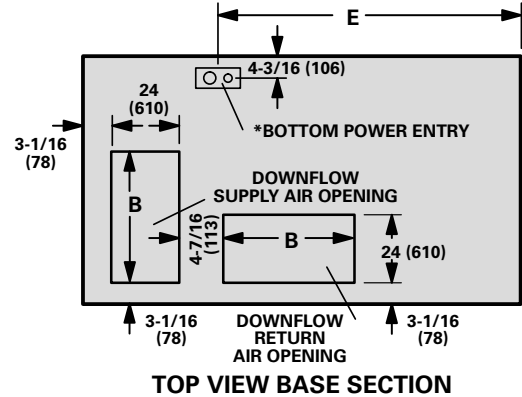

Model No.	A		B		C		D		E	
	in.	mm	in.	mm	in.	mm	in.	mm	in.	mm
GCS24-1353	98	2489	30-3/8	772	33	838	68	1727	57-1/2	1461
GCS24-1603	106	2692	38	965	41	1041	76	1930	29-1/2	749

ACCESSORY DIMENSIONS – inches (mm)

**GCS24-1353 & 1603 UNITS WITH REMD24M DOWN-FLOW ECONOMIZER DAMPER SECTION
AND RMF16 ROOF MOUNTING FRAME
(Down-Flo Position Only)**

CORNER WEIGHTS – lbs. (kg)

Model No.	AA		BB		CC		DD	
	lbs.	kg	lbs.	kg	lbs.	kg	lbs.	kg
GCS24-1353	329	149	360	163	398	181	364	165
GCS24-1603	349	158	428	194	415	188	339	154

CENTER OF GRAVITY – in. (mm)

Model No.	EE		FF	
	in.	mm	in.	mm
GCS24-1353	28-1/2	725	47	1188
GCS24-1603	30-1/2	775	47-1/2	1206

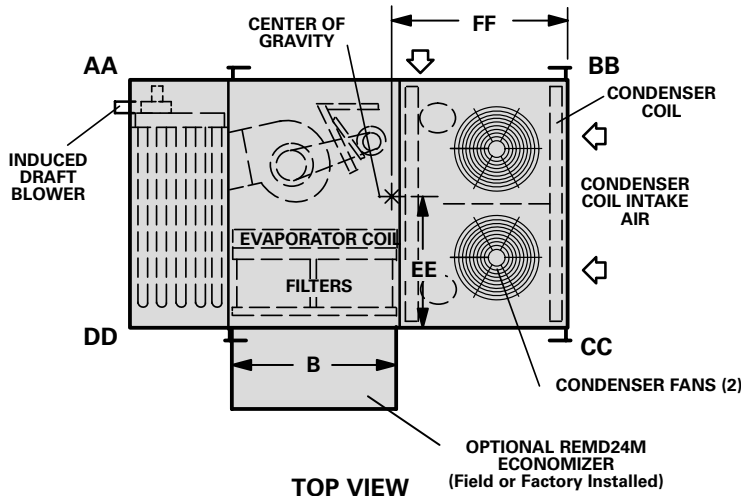

TOP VIEW

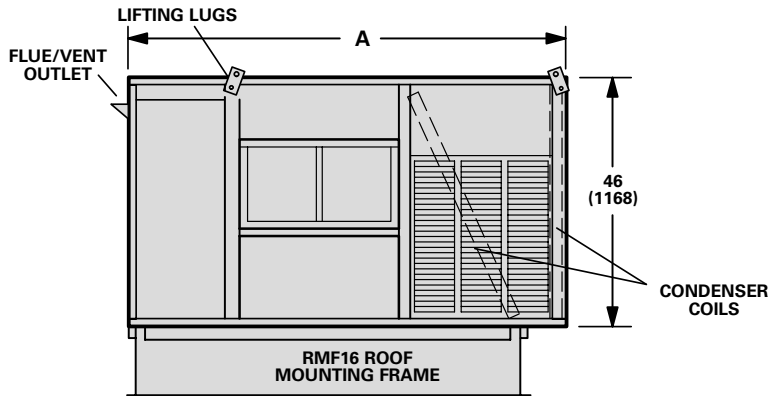

BACK VIEW

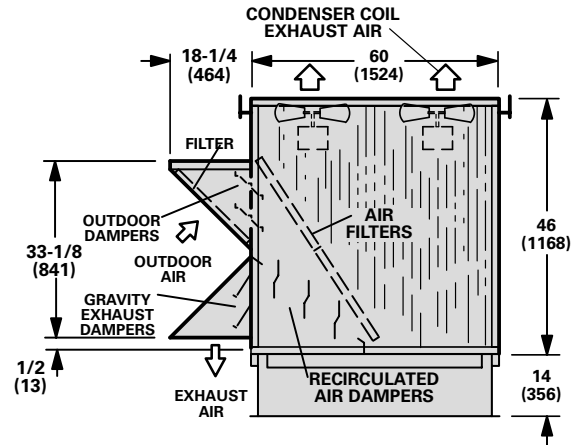

CONDENSER SECTION END VIEW

Model No.	A		B	
	in.	mm	in.	mm
GCS24-1353	98	2489	32-1/2	826
GCS24-1603	106	2692	40-1/2	1029

ACCESSORY DIMENSIONS – inches (mm)

**GCS24-1353 & 1603 UNITS WITH
EMDH16M HORIZONTAL ECONOMIZER DAMPER SECTION**

CORNER WEIGHTS – lbs. (kg)

Model Number	AA		BB		CC		DD	
	lbs.	kg	lbs.	kg	lbs.	kg	lbs.	kg
GCS24-1353	295	134	320	145	404	183	372	169
GCS24-1603	314	142	382	173	419	190	345	156

CENTER OF GRAVITY – inches (mm)

Model Number	EE		FF	
	inch	mm	inch	mm
GCS24-1353	26-1/2	674	47	1194
GCS24-1603	28-1/2	727	48	1219

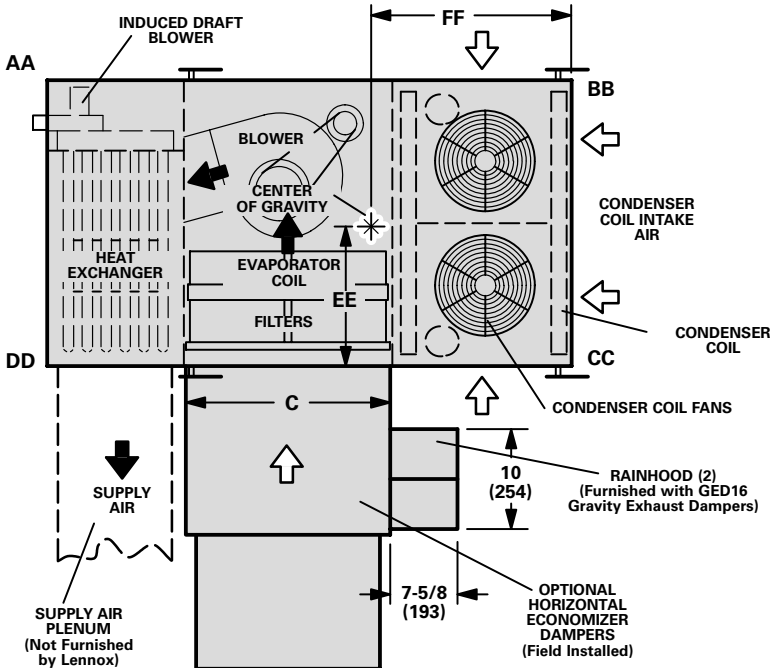

NOTE – EMDH16M requires field modification to GCS24 filter access door for proper fit.

TOP VIEW

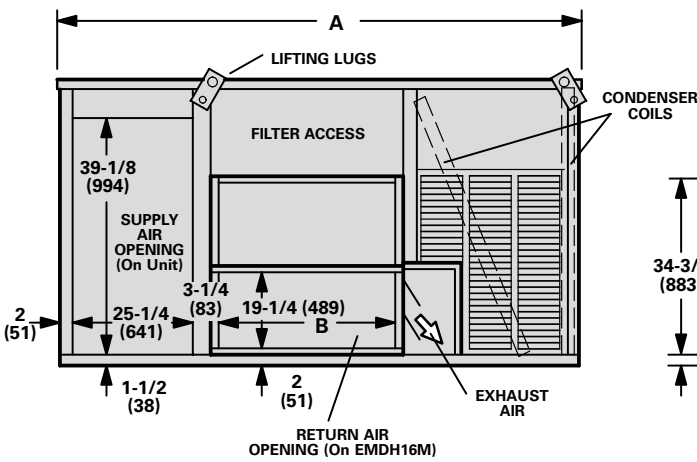

BACK VIEW

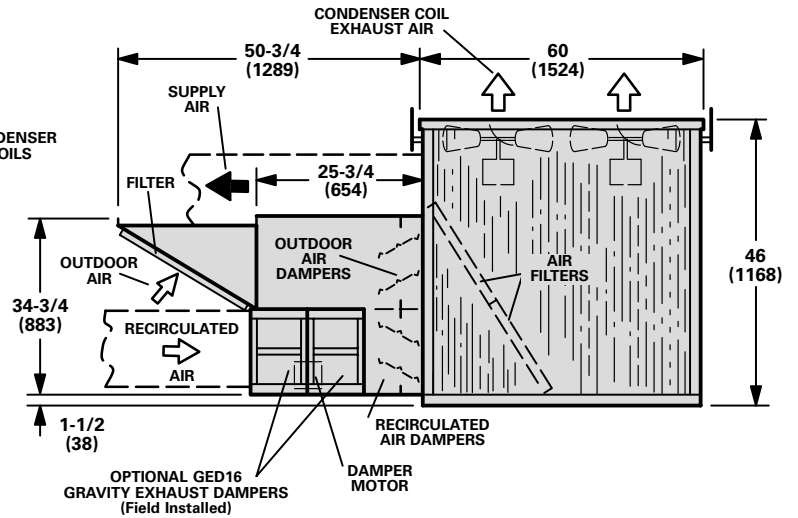

CONDENSER SECTION END VIEW

Model Number	A		B		C	
	inch	mm	inch	mm	inch	mm
GCS24-1353	98	2489	31-1/2	800	32-9/16	827
GCS24-1603	106	2692	39-1/2	1003	40-9/16	1030

UNIT DIMENSIONS – inches (mm)

GCS24-3003 (GCS24-3003-235 Size Shown)

CORNER WEIGHTS – lbs. (kg)

Model Number	AA		BB		CC		DD	
	lbs.	kg	lbs.	kg	lbs.	kg	lbs.	kg
GCS24-3003-235	484	220	567	257	987	448	842	382
GCS24-3003-470	517	236	606	275	1056	479	901	409

CENTER OF GRAVITY – inches (mm)

Model Number	EE		FF	
	inch	mm	inch	mm
GCS24-3003-235	101	2565	45-7/8	1165
GCS24-3003-470				

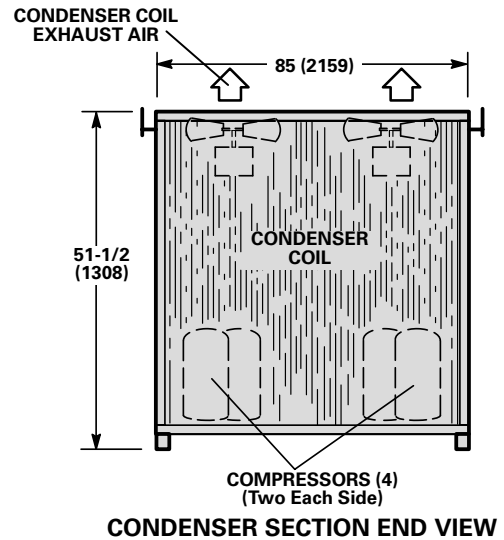
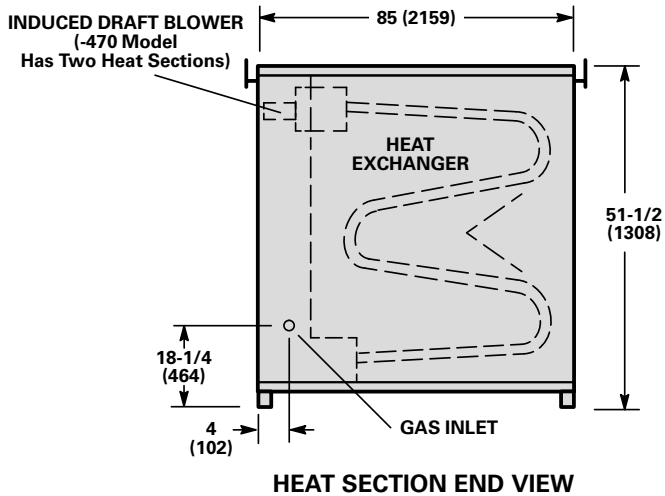
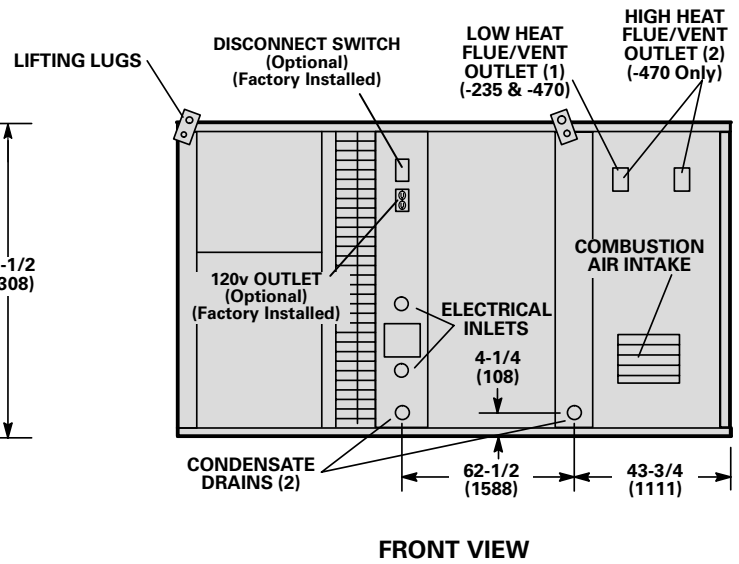
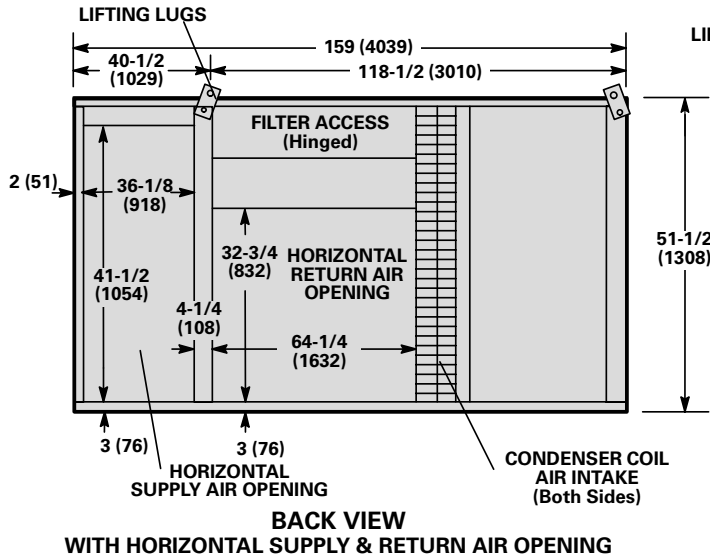
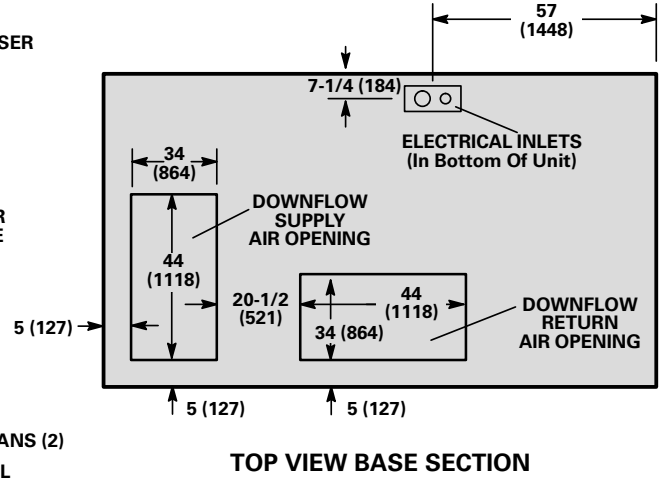
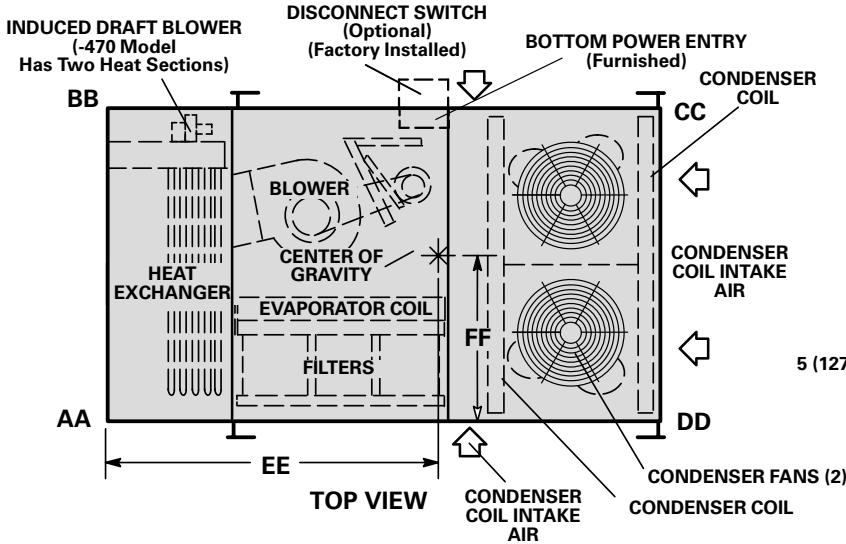

ACCESSORY DIMENSIONS – inches (mm)

**GCS24-3003 UNIT (GCS24-3003-235 Size Shown)
WITH REMD16M ECONOMIZER DAMPER SECTION AND RMF16 ROOF MOUNTING FRAME
(DOWN-FLOW APPLICATION)**

CORNER WEIGHTS – lbs. (kg)

Model Number	AA		BB		CC		DD	
	lbs.	kg	lbs.	kg	lbs.	kg	lbs.	kg
GCS24-3003-235	648	294	616	280	977	444	1028	467
GCS24-3003-470	688	312	664	297	1037	471	1091	495

CENTER OF GRAVITY – inches (mm)

Model Number	EE		FF	
	inch	mm	inch	mm
GCS24-3003 GCS24-3003	97-1/2	2477	41-1/2	1054

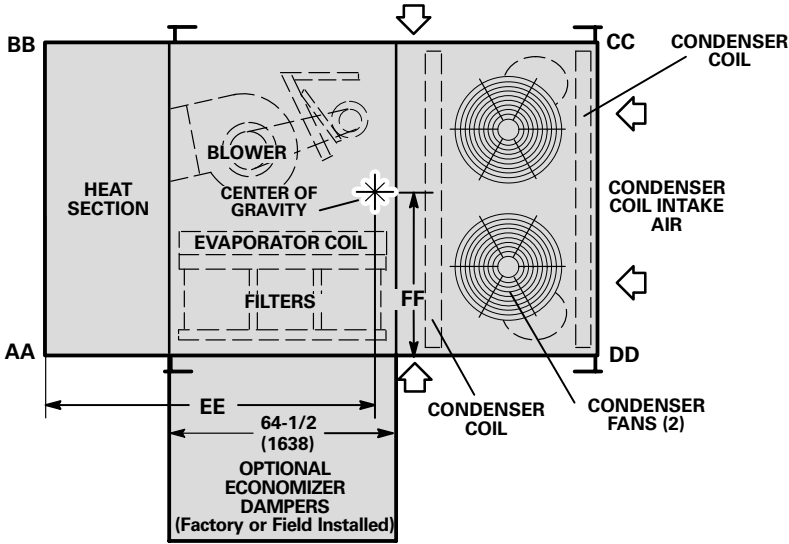

TOP VIEW

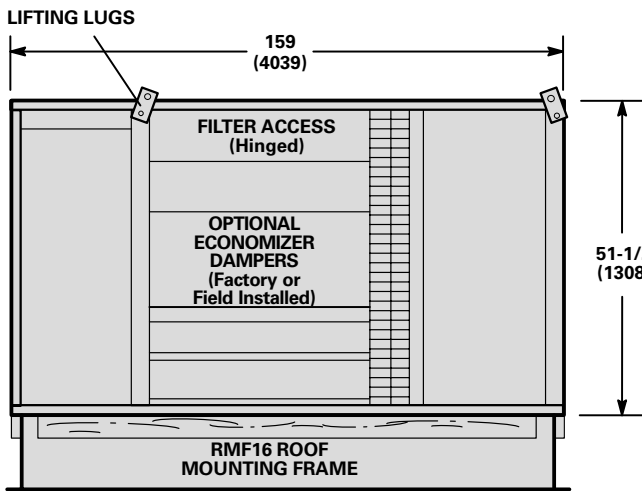

BACK VIEW

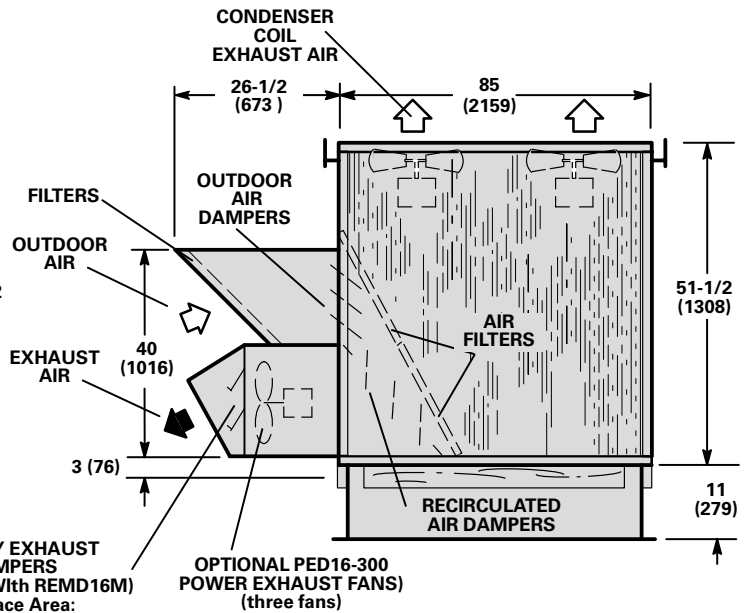

CONDENSER SECTION END VIEW

ACCESSORY DIMENSIONS – inches (mm)

**GCS24-3003 UNIT (GCS24-3003-235 Size Shown)
WITH REMD16M ECONOMIZER DAMPER SECTION
(HORIZONTAL APPLICATION)**

CORNER WEIGHTS – lbs. (kg)

Model Number	AA		BB		CC		DD	
	lbs.	kg	lbs.	kg	lbs.	kg	lbs.	kg
GCS24-3003-235	613	278	582	264	924	419	972	441
GCS24-3003-470	652	296	620	281	983	446	1035	470

CENTER OF GRAVITY – inches (mm)

Model Number	EE		FF	
	inch	mm	inch	mm
GCS24-3003-235 GCS24-3003-470	97-1/2	2477	41-1/2	1054

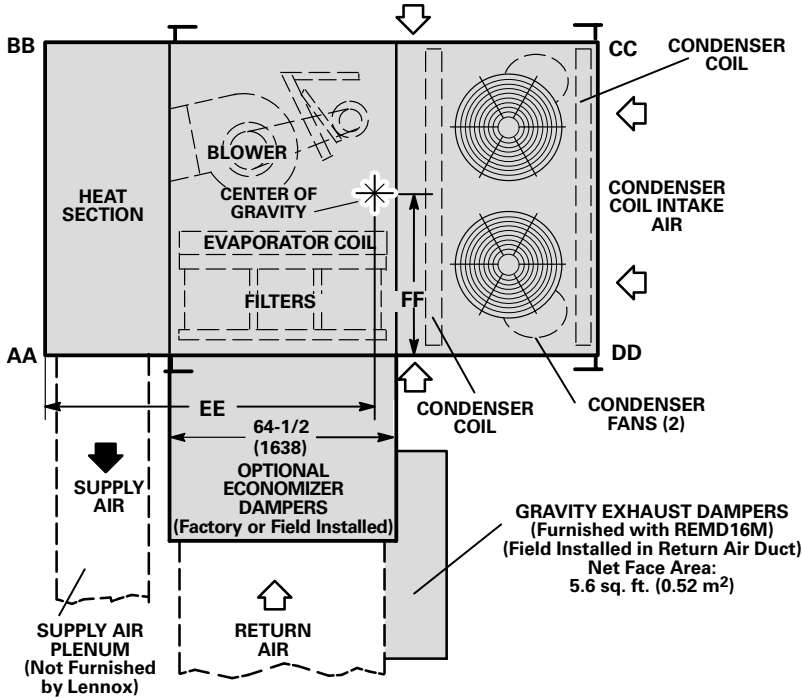

TOP VIEW

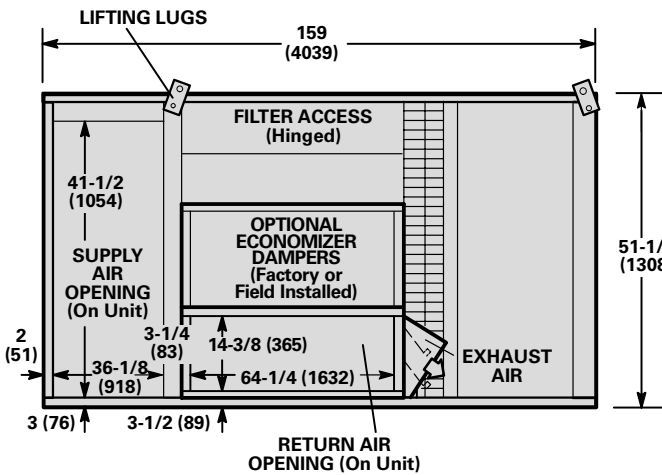

BACK VIEW

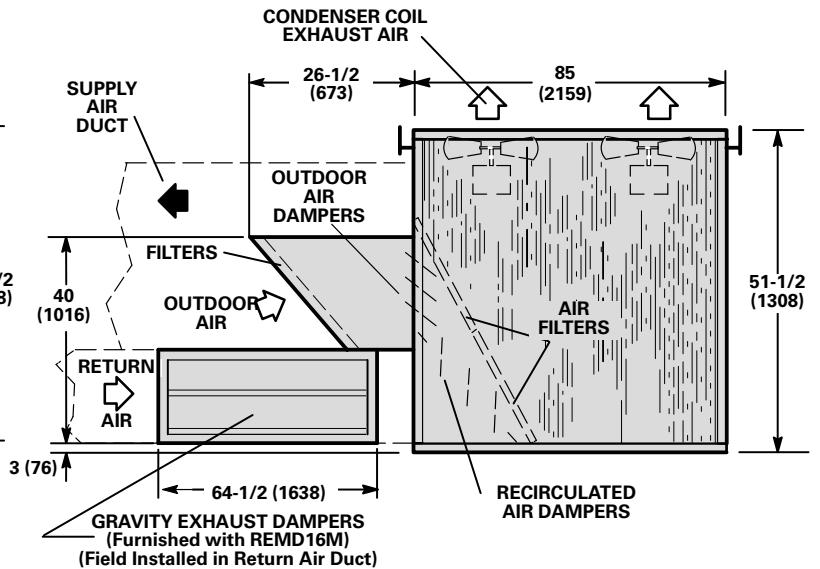

CONDENSER SECTION END VIEW

ACCESSORY DIMENSIONS – inches (mm) U.S. Only

RMF16 SERIES ROOF MOUNTING FRAME WITH DOUBLE DUCT OPENING

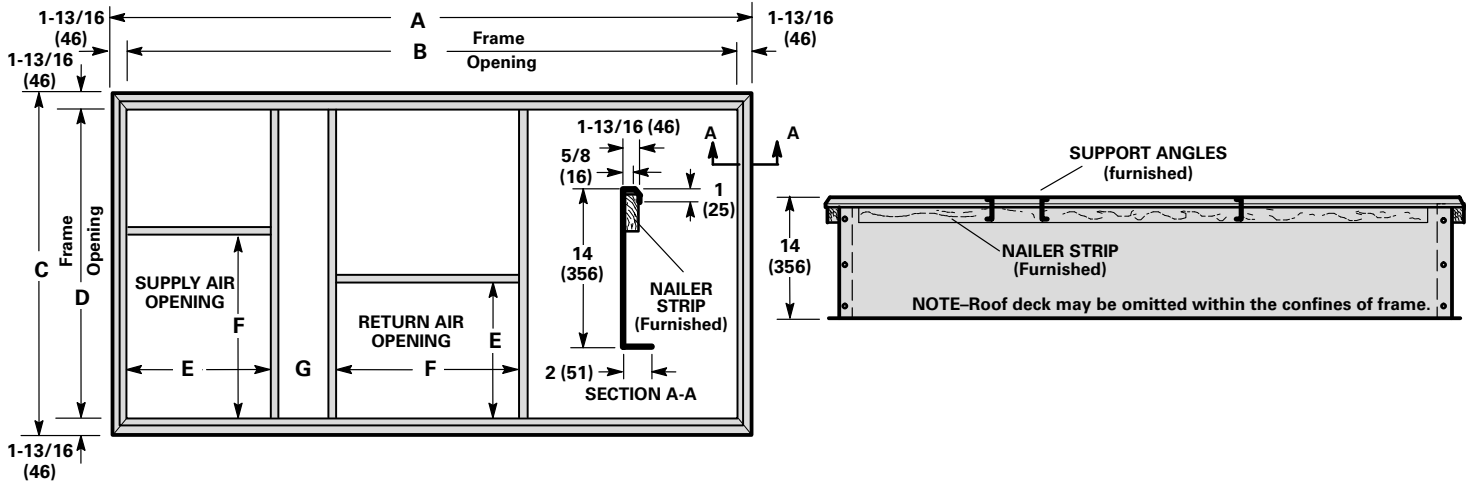

Model No.	A		B		C		D		E		F		G	
	inch	mm	inch	mm	inch	mm	inch	mm	inch	mm	inch	mm	inch	mm
RMF16-95	87-1/8	2213	83-1/2	2121	46-5/8	1184	43	1092	17-15/16	456	31-1/2	800	4	102
RMF16-135/160	92-1/2	2350	88-7/8	2257	58-1/2	1486	54-7/8	1394	25-1/4	641	*	*	3-3/16	81
RMF16-300	156-5/16	3970	152-11/16	3878	80-7/8	2054	77-1/4	1962	36	914	46	1168	18	457

*31-1/2 inches (800 mm) for -1353 units. 39-1/2 inches (1003 mm) for -1603 units.

**RMF16-95 ROOF MOUNTING FRAME WITH SRT16-95
SUPPLY AND RETURN AIR TRANSITIONS FOR FD11-95 & RTD11-95 CEILING DIFFUSERS**

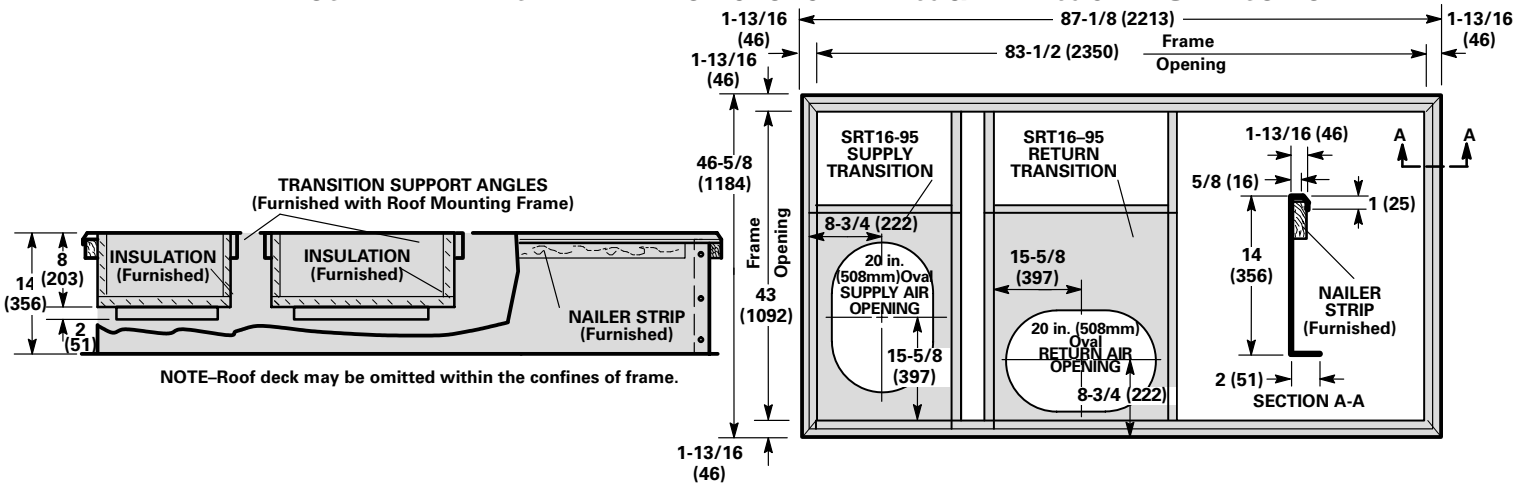

**RMF16-135/160 & RMF16-300 ROOF MOUNTING FRAMES WITH SRT16
SUPPLY AND RETURN AIR TRANSITIONS FOR FD11 & RTD11 CEILING DIFFUSERS**

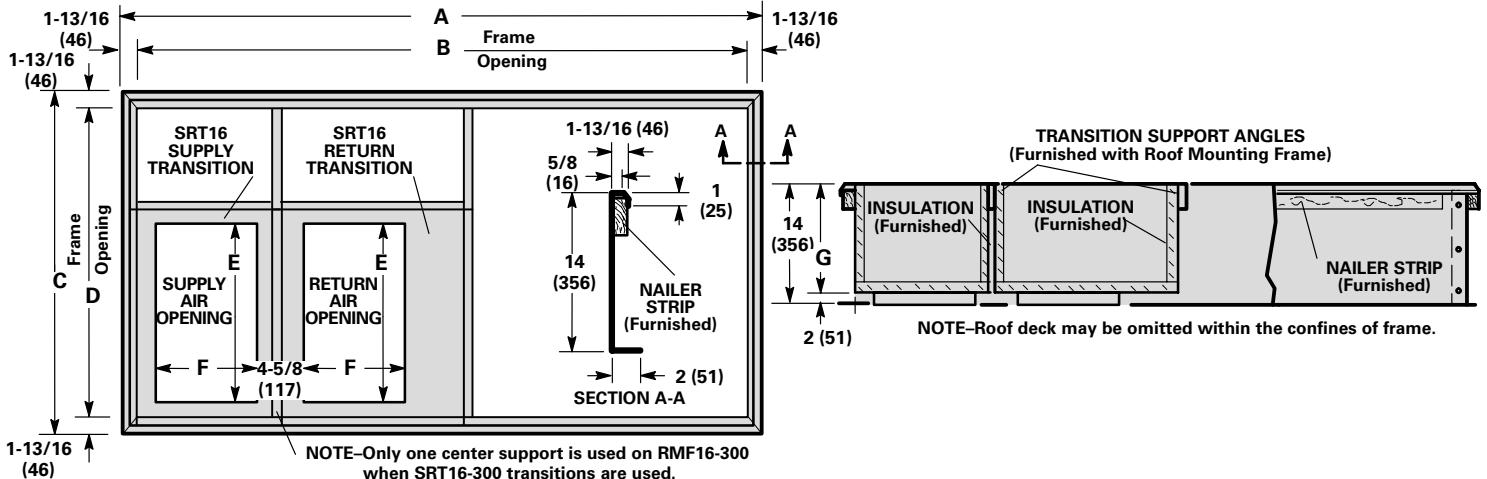

Model No.	A		B		C		D		E		F		G	
	inch	mm	inch	mm	inch	mm	inch	mm	inch	mm	inch	mm	inch	mm
RMF16-135/160	92-1/2	2350	88-7/8	2257	58-1/2	1486	54-7/8	1394	*	*	18	457	8	203
RMF16-300	156-5/16	3970	152-11/16	3878	80-7/8	2054	77-1/4	1962	48	1219	24	610	12	305

*28 inches (711 mm) for SRT16-135 units. 36 inches (914 mm) for SRT16-160 units.

TYPICAL FLASHING DETAIL FOR RMF16 ROOF MOUNTING FRAME

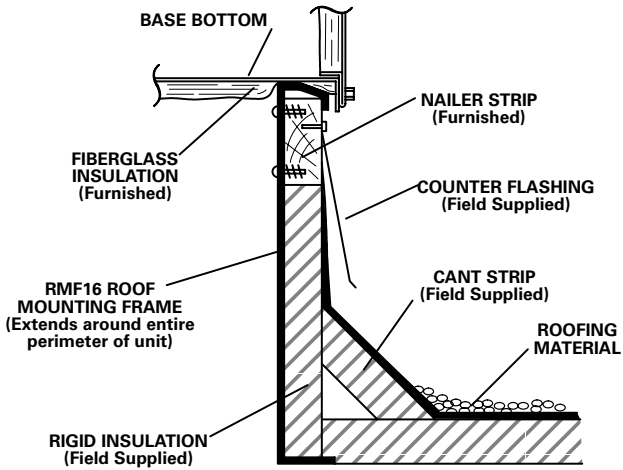

ROOF MOUNTING FRAME SPECIFICATIONS

Roof Mounting frame is rigid enough to be spanned over its entire length or cantilevered if supported on both sides of center of gravity.

Roof Mounting Frames	RMF16
*Moment of inertia (I) (in. ⁴) (cm ⁴)	42 (1748)
*Section modulus $\frac{I}{C}$ (in. ³) (cm ³)	5.8 (95)
Maximum weight (lb/ft) (kg/m) of length	5.5 (8.2)
Design strength (psi) (kPa)	20,000 (137,900)

*Includes both sides of frame.

**GCS24 UNIT WITH OAD24 OUTDOOR AIR DAMPER SECTION
DOWN-FLO SUPPLY AND RETURN AIR**

NOTE – For Horizontal (Side) Supply And Return Air, OAD24 Field Installs on Return Air Duct

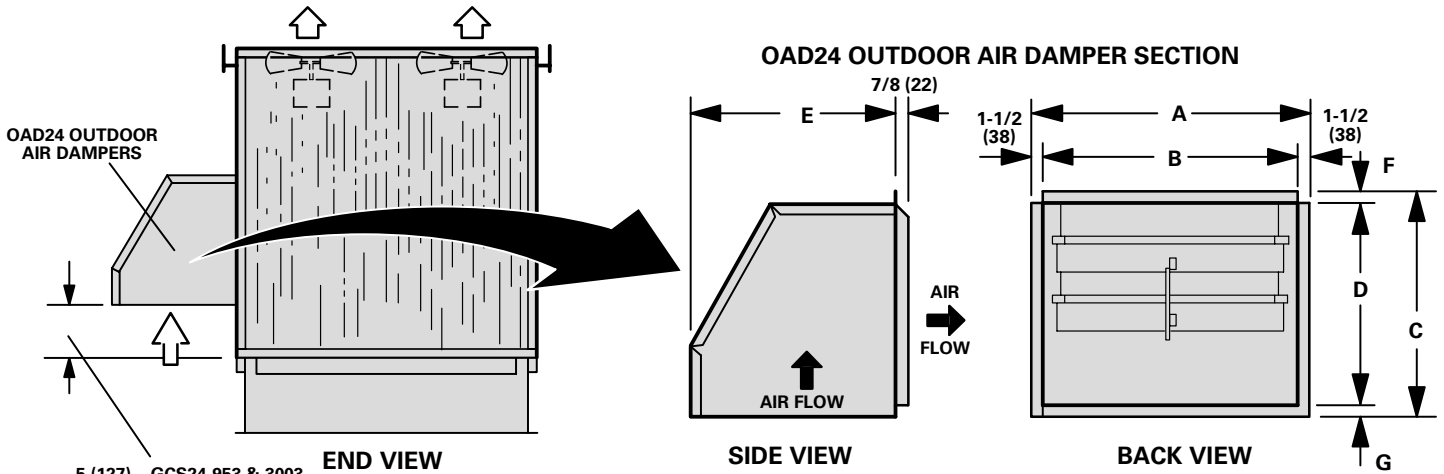

5 (127) – GCS24-953 & 3003
12-15/16 (329) – GCS24-1353 & 1603

Model Number	A		B		C		D		E		F		G	
	inch	mm	inch	mm	inch	mm	inch	mm	inch	mm	inch	mm	inch	mm
OAD24-95 OAD24-135 OAD24-160	24	610	21	533	18-1/2	470	17-1/8	435	17-1/8	435	3/4	19	5/8	16
OAD24-300	33	838	30	762	34-5/8	879	33-1/4	845	34-1/4	870	1-1/2	38	1-1/2	38

COMBINATION CEILING SUPPLY AND RETURN DIFFUSERS

RTD11-95 STEP-DOWN CEILING DIFFUSER

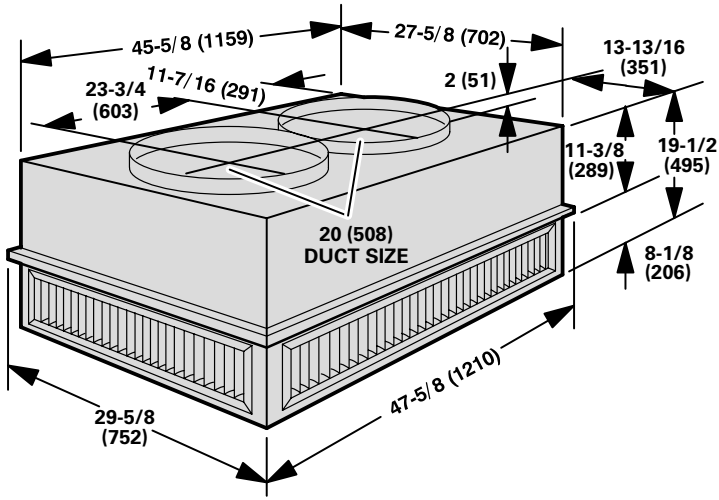

FD11-95 FLUSH CEILING DIFFUSER

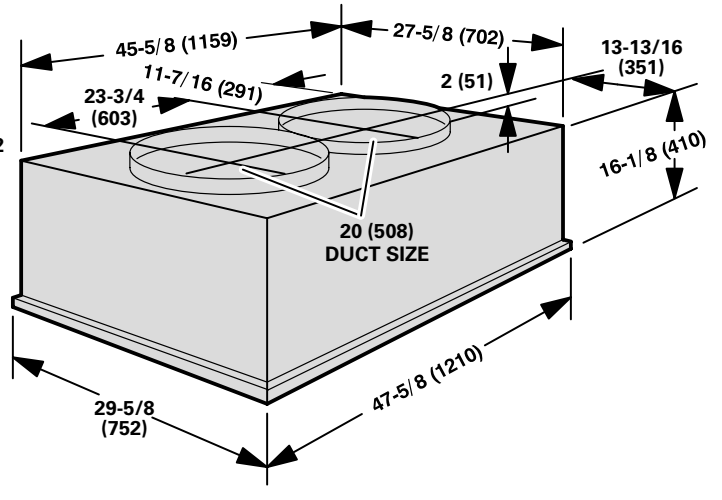

**RTD11-135, RTD11-185 & RTD11-275
STEP-DOWN CEILING DIFFUSERS**

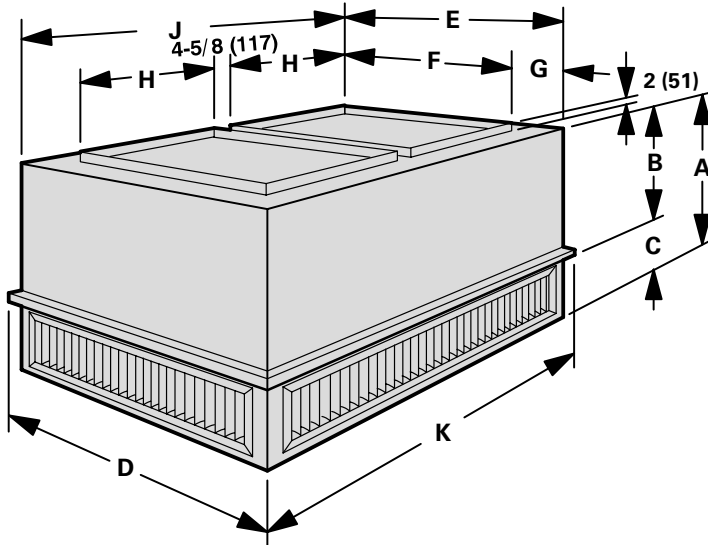

**FD11-135, FD11-185 & FD11-275
FLUSH CEILING DIFFUSERS**

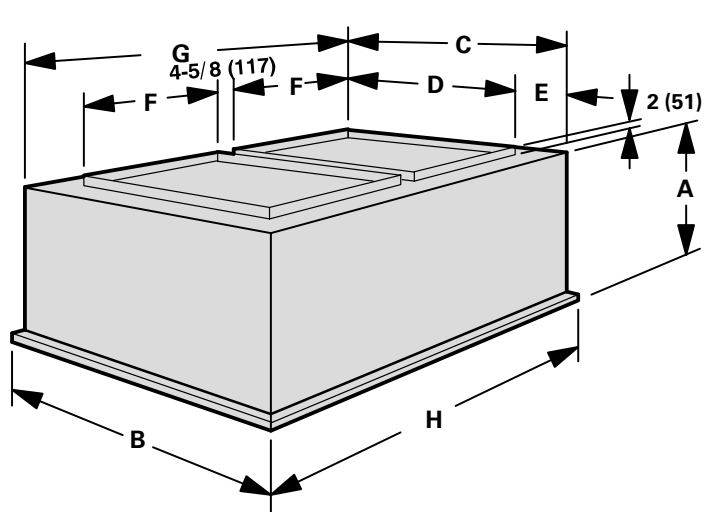

Model Number	A		B		C		D		E	
	in.	mm	in.	mm	in.	mm	in.	mm	in.	mm
RTD11-135	28	711	18-7/8	479	9-1/8	232	35-5/8	905	33-5/8	854
RTD11-185	34	864	23-7/8	606	10-1/8	257	47-5/8	1210	45-5/8	1159
RTD11-275	40	1016	28-7/8	725	11-1/8	283	59-5/8	1514	57-7/8	1470

Model Number	A		B		C		D	
	in.	mm	in.	mm	in.	mm	in.	mm
FD11-135	24-1/8	613	35-5/8	905	33-5/8	854	28	711
FD11-185	30-1/8	765	47-5/8	1210	45-5/8	1159	36	914
FD11-275	36-1/8	918	59-5/8	1514	57-5/8	1464	48	1219

Model Number	F		G		H		J		K	
	in.	mm	in.	mm	in.	mm	in.	mm	in.	mm
RTD11-135	28	711	2-13/16	71	18	457	45-5/8	1159	47-5/8	1210
RTD11-185	36	914	4-13/16	122	18	457	45-5/8	1159	47-5/8	1210
RTD11-275	48	1219	4-13/16	122	24	610	57-5/8	1464	59-5/8	1521

Model Number	E		F		G		H	
	in.	mm	in.	mm	in.	mm	in.	mm
FD11-135	2-13/16	71	18	457	45-5/8	1159	47-5/8	1210
FD11-185	4-13/16	122	18	457	45-5/8	1159	45-5/8	1210
FD11-275	4-13/16	122	24	610	57-5/8	1464	59-5/8	1521

GCS24 BASIC UNIT

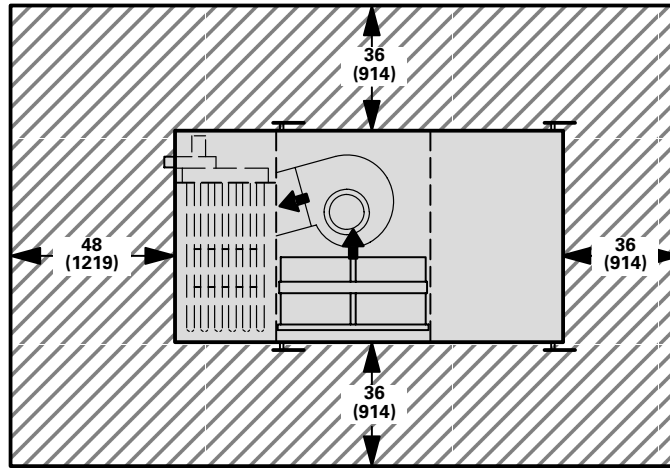

NOTE — Top Clearance Unobstructed.
 NOTE — Entire perimeter of unit requires support when elevated above mounting surface.

GCS24 UNIT WITH REMD24M ECONOMIZER DAMPER SECTION OR OAD24 OUTDOOR AIR DAMPER SECTION

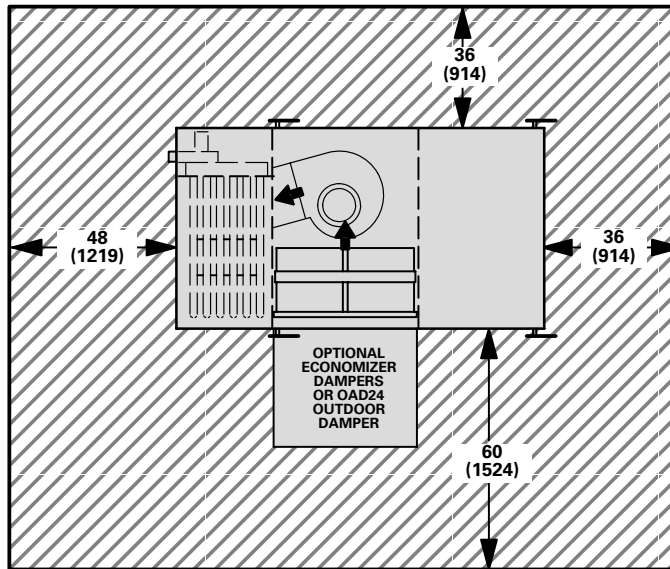

NOTE — Top Clearance Unobstructed.

GCS24 UNIT WITH EMDH16M HORIZONTAL ECONOMIZER DAMPER SECTION

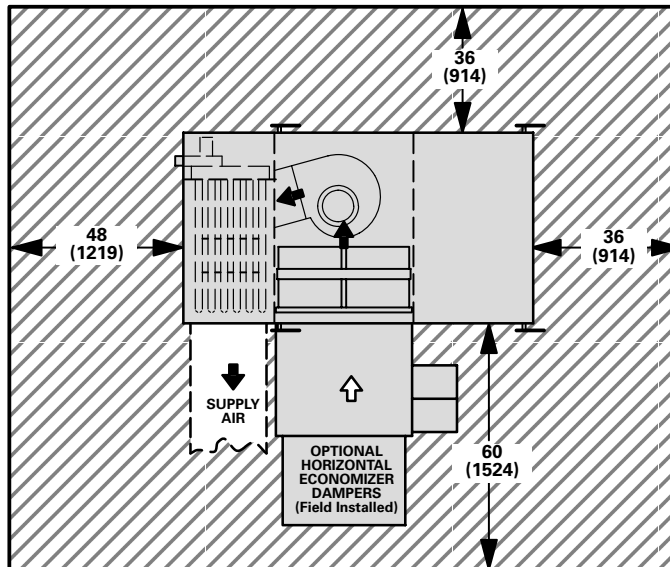

NOTE — Top Clearance Unobstructed.