

EPIC[™] SERIES

GHP24D-651-653

DUAL FUEL

PACKAGED HEAT PUMP UNITS

***59,000 Btuh (17.3 kW) Cooling Capacity**

***58,000 Btuh (17.0 kW) Heating Capacity**

95,000 or 130,000 Btuh (28.8 or 38.1 kW) Input Heating Capacity

*ARI Standard Ratings

GHP24

**(5 Ton)
(17.6 kW)**

Bulletin No. 210046
April 1995
Supersedes July 1994

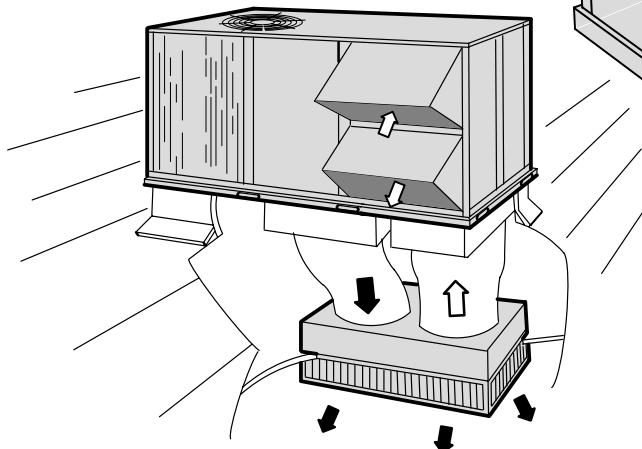
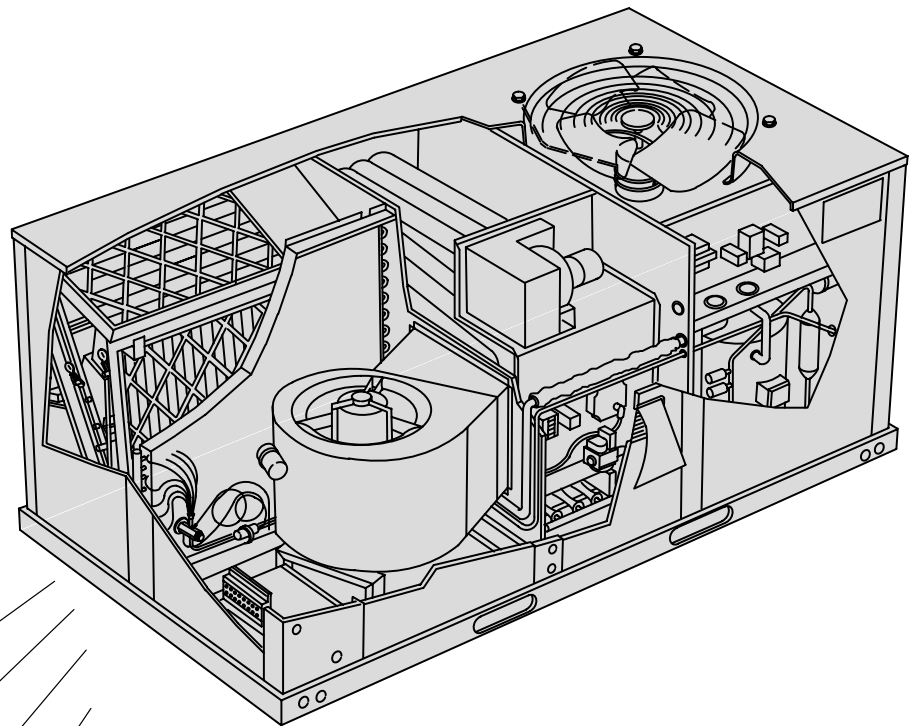

Down-Flo Supply and Return Air Installation
With RMF24 Roof Mounting Frame, REMD24M Economizer
and RTD11-95 Diffuser.

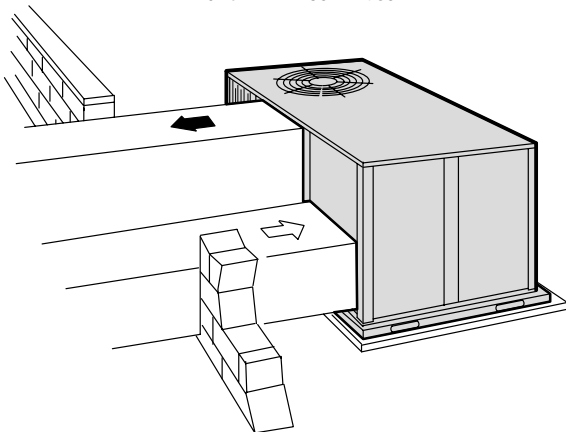

Horizontal (Side) Supply and Return Air Installation.

Table of Contents

Features	Page 2
Accessories	Page 3
Temperature Control Systems	Page 4
Temperature Control Flowcharts	Page 5
Field Wiring	Page 6
Specifications	Page 7
Field Installed Accessories	Page 8
Electrical Data	Page 8
Model Number Identification	Page 9
Factory Installed Options Selection	Page 10
Cooling Ratings	Page 11
Blower Data	Page 11-12
Guide Specifications	Page 13
Dimensions	Page 14
Dimensions - Accessories	Page 15-18
Installation Clearances	Page 18

FEATURES

Item	GHP24D-651-653
Air Flow Choice — Bottom (down-flow) or horizontal (side) supply and return air	Standard
Application — Combines a standard single package heat pump with gas fired heating section, heat pump section supplies primary conditioned for heating, gas heat section provides supplemental heating	Standard
Approvals — A.G.A./C.G.A. certified as combination heating/cooling unit for outdoor installation, U.L. and C.G.A. listed, components bonded for grounding to meet safety standards for servicing required by U.L., C.G.A. and National and Canadian Electrical Codes, meet California Nitrogen Oxides (NO _x) standards and California Seasonal Energy Requirements	Standard
ARI Standard 210/240-89 Certified Ratings	Standard
Bottom Power Entry	Standard
Cabinet — Heavy gauge galvanized steel, base section and cabinet panels fully insulated, powdered enamel paint finish, large removeable access panels, electrical inlets in cabinet base and blower section cabinet panel, combustion air intake and exhaust hoods furnished for field installation, unit lifting holes in base rails	Standard
Coil Construction (Indoor and Outdoor) — Copper tube construction, ripple-edged enhanced aluminum fins, flared shoulder tubing connections, silver soldered construction, factory tested, indoor coil features rifled tubing, evaporator coil drain connection flush with unit cabinet, sloped drain pan for positive drainage	Standard
Compressors — Reciprocating type, hermetically sealed, suction cooled, overload protected, resiliently mounted	Standard
Compressor Crankcase Heaters	Standard
Outdoor Coil — Formed coil construction	Standard
Outdoor Coil Fan — Low sound operating levels, PVC coated fan guard furnished	Standard
Outdoor Coil Fan Motor — Overload protected, permanently lubricated, ball bearings	Standard
Control Box — Control box with factory installed controls conveniently located, 24 volt control transformer with fuse, low voltage terminal strip	Standard
Control Box Panel — Hinged for easy access	Standard
Defrost Control — Solid-state clock timer defrost control, provides defrost cycle if needed every 30, 60 or 90 minutes (adjustable) of compressor "on" time at outdoor temperatures below 45°F (7°C), pressure switch on outdoor coil vapor line determines when defrost cycle is required and when to terminate cycle	Standard
Fan and Limit Controls — Factory installed, 90 second fan time delay, dual limit controls (primary and secondary) with fixed temperature setting	Standard
Filters — Disposable 2 inch (51 mm) commercial grade	Standard
Filter Access — Hinged filter door with quarter turn fasteners	Standard
Heat Exchanger — Tubular construction, aluminized steel, compact size, life cycle tested	Standard
Heating System — Aluminized steel inshot burners, direct spark ignition, electronic flame sensor, redundant automatic dual gas valve with manual shut-off and pressure regulation, 95/130 models have two stage heating operation, induced draft blower with blower proving switch, flame rollout switch, peep hole for flame viewing	Standard
Refrigeration System — Consists of: compressor, outdoor coil and direct drive fan, indoor coil and direct drive drive blower, check and expansion valve, high capacity drier, defrost control, thermometer well, high pressure switch, loss of charge switch, reversing valve, suction line accumulator, suction and liquid line service gauge ports, full refrigerant charge, freezestat (prevents indoor coil freeze-up during low ambient operation or restricted air flow to coil)	Standard
Supply Air Blower — Direct drive, multi-speed motor, blower wheel statically and dynamically balanced, sleeve bearings with oiler ports	Standard
Warranty — Limited ten years heat exchanger, limited five years compressor, limited one year all other components, see limited warranty certificate included with unit for details	Standard

OPTIONAL FACTORY INSTALLED ACCESSORIES

Item	GHP24D-651-653
Corrosion Protection — Phenolic epoxy coating applied to condenser coil only (with painted base section) or to both condenser and evaporator coil (with painted condenser and evaporator base section and painted blower housing), factory applied	*Factory
Disconnect	*Factory
Service Outlets (2) — Factory installed, 120v ground fault circuit interrupter (GFCI) type	*Factory
Smoke Detector — Photoelectric type, factory installed in return air section	*Factory

*See Factory Installed Options tables.

OPTIONAL FACTORY OR FIELD INSTALLED ACCESSORIES

Item	GHP24D-651-653
Economizer Dampers (Down-Flow or Horizontal) — Mechanically linked recirculated air and outdoor air dampers, plug-in connections to unit, nylon bearings, stainless steel seals (outdoor dampers), 24 volt fully modulating spring return damper motor, adjustable minimum damper position switch, mixed air controller, solid-state adjustable outdoor air enthalpy control, 0 to 100% outdoor air adjustable, cleanable aluminum mesh frame filter furnished, fresh air hood and exhaust air hood with gravity exhaust dampers furnished for field installation, powdered enamel paint finish, exhaust dampers field install in return air duct for horizontal applications	†REMD24M-81
Low Ambient Controls — Allows unit cooling operation down to 30°F (-1°C). NOTE — Unit operates down to 45°F (7.2°C) without controls	†Factory or Field Installed
Outdoor Air Damper Section (Manual) — Linked mechanical dampers, interchangeable unit panel with lower filler panel furnished to replace return air access panel, 0 to 25% (fixed) outdoor air adjustable	†OAD24-81

†See Optional Field Installed Accessories tables. Also see Factory Installed Options tables.

OPTIONAL ACCESSORIES (Must Be Ordered Extra)

Item	GHP24D-651-653
❖ Cold Weather Kit — Electric heater automatically controls minimum temperature in gas burner compartment when temperature is below -40°F (-40°C). C.G.A. certified to allow operation of unit down to -60°F (-50°C)	Optional
Control System — Electro-mechanical Thermostat	Optional
Control System — W973	Optional
Control System — T7300 Thermostat	Optional
Control System — W7400	Optional
❖ Control System — T8600 and T8621 Thermostat	Optional
Differential Enthalpy Control — For use with economizer dampers, solid-state return air sensor allows selection between outdoor air and return air (whichever has lowest enthalpy)	Optional
Diffusers (Step-Down) — Aluminum grilles, double deflection louvers, large center grille, insulated diffuser box with flanges, hanging rings furnished, interior transition (even air flow), internally sealed (prevents recirculation), adapts to T-bar ceiling grids or plaster ceilings	RTD11-95
Diffusers (Flush) — Aluminum grilles, fixed blade louvers, large center grille, insulated diffuser box with flanges, hanging rings furnished, interior transition (even air flow), internally sealed (prevents recirculation), adapts to T-bar ceiling grids or plaster ceilings	FD11-95
Transitions (Supply and Return) — Used with diffusers, installs in roof mounting frame, galvanized steel construction, flanges furnished for duct connection, fully insulated	SRT24-81
Horizontal Supply and Return Air Kit — Provides duct connection to unit, flanges furnished, hardware furnished, two covers furnished for unused air openings, filter access panel furnished	HDK24-81
LPG/Propane Kits	Optional
Outdoor Air Damper Section (Automatic) — Linked mechanical dampers, interchangeable unit panel with lower filler panel furnished to replace return air access panel, damper motor with thumbwheel for adjusting fresh air amount desired	OAD24M-81
Roof Mounting Frame — Nailer strip furnished, mates to unit, U.S. National Roofing Contractors Approved, shipped knocked down	RMF24-81
Timed-Off Control — Prevents compressor short-cycling	Optional

OPTIONAL TEMPERATURE CONTROL SYSTEMS (See Flow Charts on Page 5)

System and Component Description	Catalog No.
ELECTRO-MECHANICAL THERMOSTAT CONTROL SYSTEM	
Thermostat — Two stage heat & two stage cool with dual temperature levers, subbase choice	13F06
Subbase — Manual system switch (Off-Heat-Auto-Cool), fan switch (Auto-On)	13F17
Balance Point Thermostat (Required) — Locks out compressor operation in heating mode when outdoor temperature falls below setpoint, allowing gas heat to operate for first and second stage heating, features operational mode LED's, adjustable temperature differential and tamper proof cover	39H56
Night Setback Operation — Order components below	—
Heating Thermostat — Single stage heat	13F12
Subbase — Non-switching	13F16
Nite Kit — Required if economizer is not used, contains plug-in relay, overrides operation of day thermostat	39G74
Time Clock — 7 day operation, indicates day and night periods, 2 hour increments, battery back-up	See Price Book for Selection
Time Clock — 24 hour night setback operation, 15 minute increments, battery back-up	See Price Book for Selection
Warm Up Kit — Holds economizer dampers closed during night heating operation and morning warm-up	39G77
T7300 THERMOSTAT CONTROL SYSTEM	
Thermostat — Programmable, internal or optional remote temperature sensing (sensor required), touch sensitive keyboard, automatic switching, °F or °C readout, no anticipator, droop/no droop selection, indicator LED's, hour/day programming, override capabilities, time and operational mode readout, stage status indicators, battery back-up	81G59
Subbase — Selectable staging up to three stage heat & two stage cool, manual system switch (Auto-Cool-Off-Heat-Emergency Heat) (heat pump only), fan switch (Auto-On), indicator LED's, auxiliary relay output controls economizer operation during occupied and unoccupied periods, heat pump compressor provides first stage of heating requirement, 1st stage gas heat provides the second stage, heat pump and gas heat may operate simultaneously if conditions warrant	13H76
Sensor — Room temperature	58C92
Sensor — Room temperature with 3 hour override and setpoint adjustment	86G67
Sensor — Return air temperature	27C40
Balance Point Thermostat (Required) — Locks out compressor operation in heating mode when outdoor temperature falls below setpoint, allowing gas heat to operate for first and second stage heating, features operational mode LED's, adjustable temperature differential and tamper proof cover	39H56
Heat Relay — To attain maximum maximum gas heat capacity (both 1st and 2nd stage), relay is required	13H78

LOGIC CONTROLS PACKAGE (Factory Installed Option)

Component Description	Catalog No.
ETM Electronic Thermostat Module — Factory installed control monitors unit operation from different sensors factory installed in unit, has outputs for 2 stage heat/2 stage cool, automatic or continuous blower operation, economizer damper operation and night setback, features: day/occupied mode with low enthalpy (outdoor air damper open), high enthalpy (outdoor air damper closed) or night/unoccupied mode (outdoor air damper closed), ETM allows units to be "daisy chained" together (up to 31 units) to be operated from one central location with an "executive" control processor (on-site or off-site), built-in time delays, built-in unit operating defaults, diagnostic LED's indicate various operating functions, surge suppression protects ETM against lightning or voltage spikes	Factory Installed In Unit
Return Air Sensor — Provides input to ETM module to determine heating or cooling operation and number of stages required	Factory Installed In Unit
Blower Proving Switch — Monitors blower operation, locks out unit in case of blower failure, sends signal to ETM module for alarm	Factory Installed In Unit
Dirty Filter Switch — Senses static pressure increase indicating a dirty filter condition	Factory Installed In Unit
Discharge Air Monitor — Senses leaving air temperature for monitoring unit operation	Factory Installed In Unit
Room Temperature Sensor — Provides input to ETM module to determine heating or cooling operation and number of stages required (ordered separately)	97H53
Night Setback Override Switch — Allows momentary override of night setback during unoccupied mode	Field Furnished

TEMPERATURE CONTROL SELECTION FLOWCHARTS

OPTIONAL ELECTRO-MECHANICAL THERMOSTAT CONTROL SYSTEM

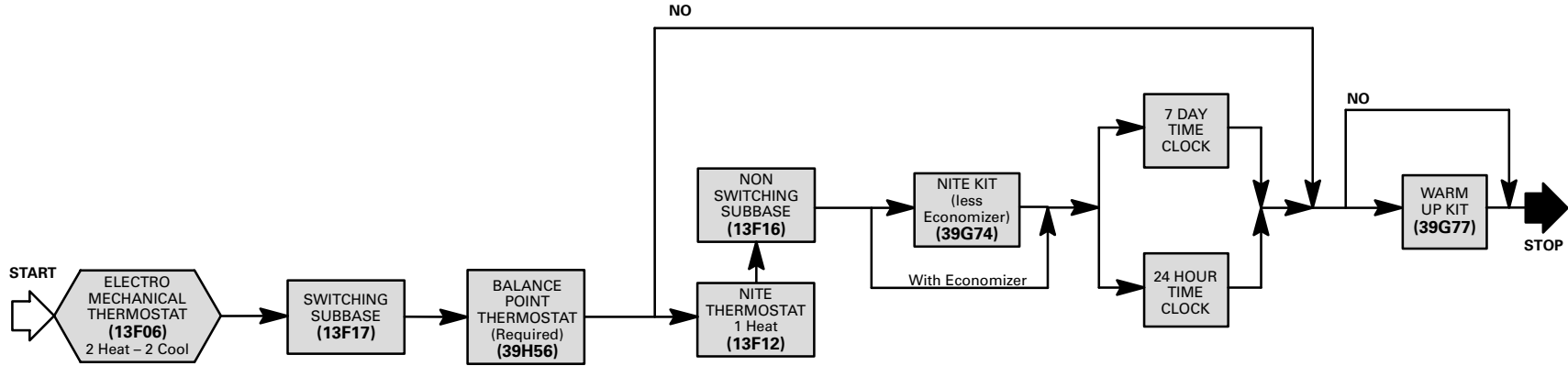

OPTIONAL T7300 CONTROL SYSTEM

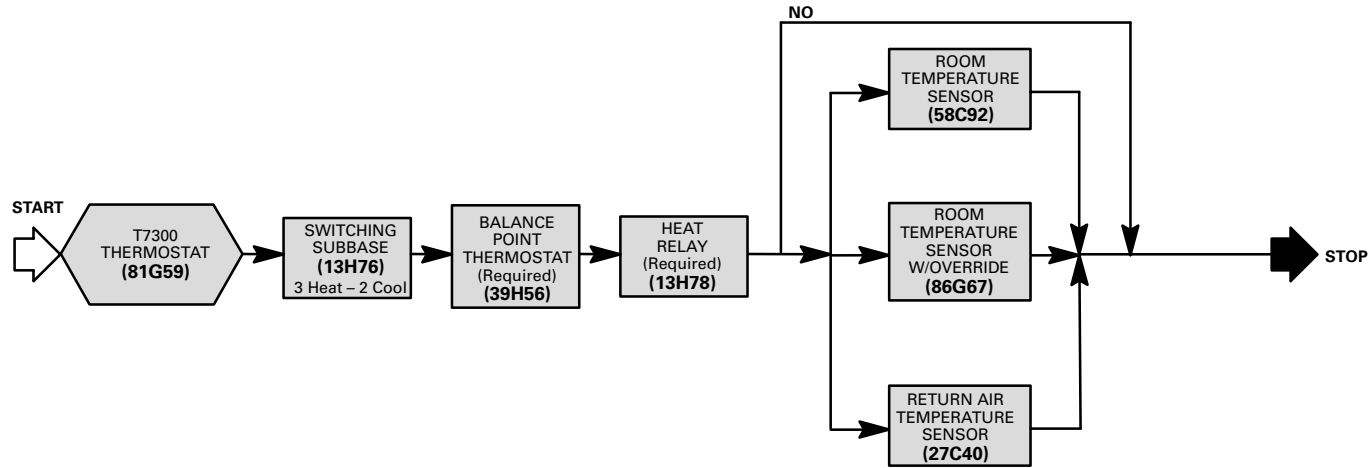

OPTIONAL LOGIC CONTROLS PACKAGE (Factory Installed)

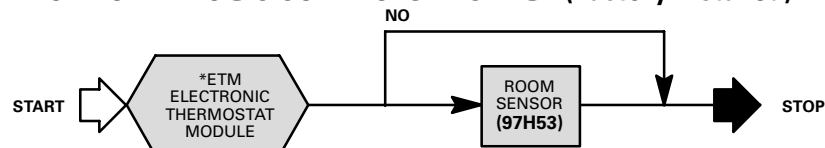

*Includes Return Air Sensor, Blower Proving Switch, Dirty Filter Switch and Discharge Air Monitor factory installed in unit.

ELECTRO-MECHANICAL THERMOSTAT CONTROL SYSTEM

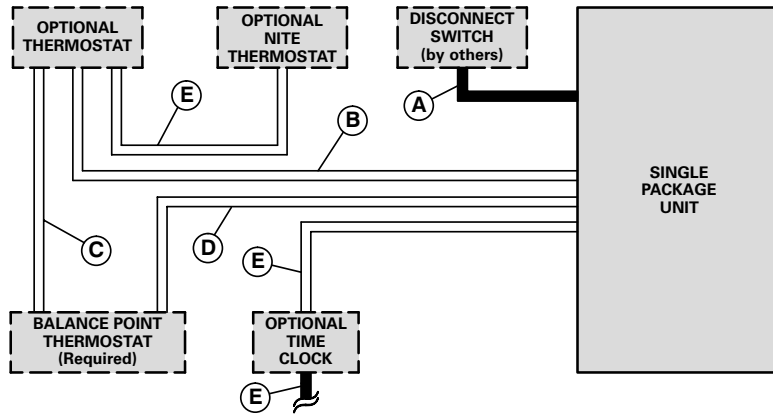

- A – Two or Three wire power (See Electrical Data Table)
- B – Six wire low voltage
- C – Two wire low voltage
 - Seven wire low voltage (with override sensor)
 - See Electrical Data
- D – One wire low voltage
- E – Two wire low voltage

– Field Wiring Not Furnished –

NOTE – All wiring must conform to NEC or CEC and local electrical codes.

T7300 THERMOSTAT CONTROL SYSTEM

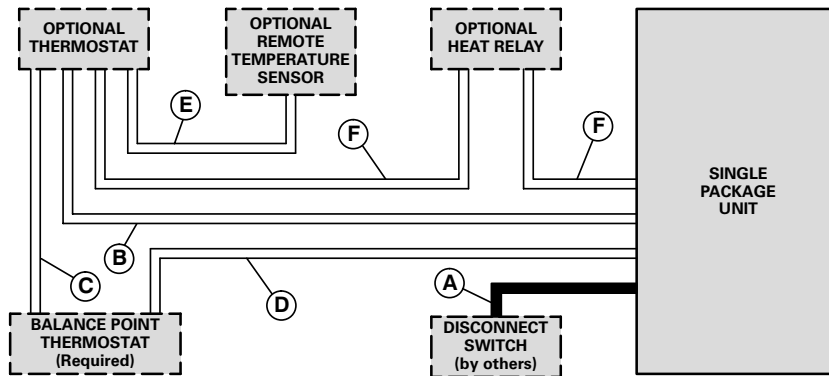

- A – Two or Three wire power (See Electrical Data Table)
- B – Nine wire low voltage
- C – Two wire low voltage
 - Seven wire low voltage (with override sensor)
- D – One wire low voltage
- E – Two wire low voltage
- F – Three wire low voltage

– Field Wiring Not Furnished –

NOTE – All wiring must conform to NEC or CEC and local electrical codes.

SPECIFICATIONS

Model No.		GHP24D-651-653-95/130	
Cooling Ratings	Gross cooling capacity — Btuh (kW)		61,000 (18.9)
	*Net cooling capacity — Btuh (kW)		59,000 (17.3)
	*Total unit watts		6590
	*SEER (Btuh/Watts)		10.0
	*EER (Btuh/Watts)		8.8
High Temperature Heating Ratings	*Total capacity — Btuh (kW)		58,000 (17.0)
	*Total unit watts		5580
	*C.O.P		3.05
	*Heating Seasonal Performance Factor (Region IV/Region V)		6.8 / 5.9
Low Temperature Heating Ratings	*Total capacity — Btuh (kW)		31,000 (9.1)
	*Total unit watts		4330
	*C.O.P		2.1
*Sound Rating Number (Bels)			8.8
Refrigerant Charge (HCFC-22)			9 lbs. 9 oz. (4.34 kg)
Heating Ratings	Sea Level Two Stage Heating Capacity (Natural Gas)	Input/Output (low) — Btuh (kW)	95,000 (27.8) / 75,000 (22.0)
		Input/Output (high) — Btuh (kW)	130,000 (38.1) / 104,000 (30.5)
		A.G.A./C.G.A. Thermal Efficiency / AFUE	80.0% / 78.0%
	Sea Level Two Stage Heating Capacity (●LPG/Propane)	Input/Output (low) — Btuh (kW)	95,000 (27.8) / 75,000 (22.0)
		Input/Output (high) — Btuh (kW)	130,000 (38.1) / 104,000 (30.5)
		A.G.A./C.G.A. Thermal Efficiency / AFUE	80.0% / 78.0%
	High Altitude Two Stage Heating Capacity (Natural Gas)	Input/Output (low) — Btuh (kW)	95,000 (27.8) / 75,000 (22.0)
		Input/Output (high) — Btuh (kW)	117,000 (34.3) / 94,000 (27.5)
		C.G.A. Thermal Efficiency	80.0%
	High Altitude Two Stage Heating Capacity (●LPG/Propane)	Input/Output (low) — Btuh (kW)	95,000 (27.8) / 75,000 (22.0)
		Input/Output (high) — Btuh (kW)	117,000 (34.3) / 94,000 (27.5)
		C.G.A. Thermal Efficiency	80.0%
Indoor Coil Blower	Blower wheel nominal diameter x width — in. (mm)		11-1/2 x 9 (292 x 229)
	Motor horsepower (W)		3/4 (560)
Indoor Coil	Net face area — sq. ft. (m ²)		6.25 (0.58)
	Tube diameter — in. (mm) & No. of rows		3/8 (9.5) — 3
	Fins per inch (m)		14 (551)
	Expansion device type		Thermostatic Expansion and Check Valve
	Drain connection (No. & size) — in. (mm) fpt		(1) 3/4 (19)
Outdoor Coil	Net face area sq. ft. (m ²)		12.9 (1.20)
	Tube diameter — in. (mm) & No. of rows		3/8 (9.5) — 2
	Fins per inch (m)		20 (787)
Outdoor Coil Fan	Diameter — in. (mm) & No. of blades		24 (610) — 3
	Air Volume — cfm (L/s)		4200 (1980)
	Motor horsepower (W)		1/3 (224)
	Motor rpm		1060
	Motor watts		460
Gas Supply Connections — in. (mm) Natural Gas or ●LPG/Propane			1/2 (12.7)
Recommended Gas Supply Pressure — wc. in. (kPa)	Natural Gas		7 (1.7)
	●LPG/Propane		11 (2.7)
Filters (furnished)	Type of filter		Pleated Disposable
	No. & size — in. (mm)		(4) 12 x 24 x 2 (305 x 610 x 51)
Net weight of basic unit — lbs. (kg)			730 (331)
Shipping weight of basic unit — lbs. (kg) 1 Package			830 (376)
Electrical characteristics			208/230v-1 or 3 ph / 460v or 575v 3ph

*Sound Rating Number in accordance with ARI Standard 270.

*Rated in accordance with ARI Standard 210/240.

Cooling Ratings— 95°F (35°C) outdoor air temperature and 80°F (27°C) db/67°F (19°C) wb entering indoor coil air.

High Temperature Heating Ratings— 47°F (8°C) db/43°F (6°C) wb outdoor air temperature and 70°F (21°C) entering indoor coil air.

Low Temperature Heating Ratings— 17°F (-8°C) db/15°F (-9°C) wb outdoor air temperature and 70°F (21°C) entering indoor coil air.

NOTE — ARI capacity is net and includes indoor blower motor heat deduction. Gross capacity does not include indoor blower motor heat deduction.

● For LPG/Propane units a field installed kit is required and must be ordered extra. See Optional Accessories table.

OPTIONAL FIELD INSTALLED ACCESSORIES – (Must Be Ordered Extra)

Unit Model No.	GHP24D-651-653-95/130	
LPG / Propane Conversion Kit	2 stage LB-65825A (45J24)	
❖ Cold Weather Kit	65C03	
Roof Mounting Frame – Net Weight	RMF24-81 (45J19) ❖(59J47) (100 lbs. (45 kg))	
Ceiling Supply and Return Air Diffusers Net Weight lbs. (kg)	Step-Down	RTD11-95 (29G04) (88 lbs.) (40 kg)
	Flush	FD11-95 (29G08) (75 lbs.) (34 kg)
	Transition	SRT24-81 (48J27) (28 lbs.) (13 kg)
Horizontal Supply and Return Air Kit – Net Weight	HDK24-81 (45J25) (20 lbs.) (9 kg)	
Economizer Dampers With Exhaust dampers	Model Number – Net Weight	REMD24M-81 (45J20) (68 lbs.) (31 kg)
	No. & size of filters – in. (mm)	(1) 16 x 25 x 1 (406 x 635 x 25)
	Exhaust Dampers Net Face Area	2.5 sq. ft. (0.23 m ²)
Differential Enthalpy Control	54G44	
Manual Outdoor Air Damper – Net Weight	OAD24-81 (45J21) (18 lbs.) (8 kg)	
Automatic Outdoor Air Damper – Net Weight	OAD24M-81 (45J22) (24 lbs.) (11 kg)	
Low Ambient Control Kit	LB-57113BM (27J00)	
Timed-Off Control	LB-50709BA (32F21)	

ELECTRICAL DATA

Model No.		GHP24D-651-653			
Line voltage data – 60 Hz		208/230v 1 phase	208/230v 3 phase	460v 3 phase	575v 3 phase
Compressor	Rated load amps	30.8	17.3	9.7	8.4
	Locked rotor amps	147	150	73	62
Outdoor Coil Fan Motor	Full load amps	2.3	2.3	1.1	††1.1
	Locked rotor amps	4.5	4.5	2.2	†† 2.2
Indoor Coil Blower Motor	Motor Output	hp	3/4	3/4	3/4
		W	560	560	560
	Full load amps	4.6	4.6	2.3	†† 2.3
	Locked rotor amps	10.0	10.0	5.4	†† 5.4
Recommended maximum fuse size (amps)		60	40	20	15
*Minimum Circuit Ampacity		46.0	29.0	16.0	13.0
Unit Power Factor		.98	.85	.86	.88

*Refer to National or Canadian Electrical Code manual to determine wire, fuse and disconnect size requirements.

†† Motors are rated at 460v. Full load amps shown are for stepdown transformer output.

NOTE – Extremes of operating range are plus and minus 10 % of line voltage.

HIGH ALTITUDE DERATE

A.G.A. certified units must be derated when installed at an elevation of more than 2000 feet (610 m) above sea level. If unit is installed at an altitude higher than 2000 feet (610 m), the unit must be derated 4% for every 1000 feet (305 m) above sea level. Thus, at an altitude of 4000 feet (1210 m), the unit would require a derate of 16%.

❖ C.G.A. certified units must be derated when installed at an elevation of more than 2000 feet (610 m) above sea level. If unit is installed at an altitude higher than 2000 feet (610 m), the unit must be derated 10% for elevations between 2000 feet and 4500 feet (610 m and 1370 m) above sea level.

NOTE – This is the only permissible derate for these units.

MODEL NUMBER IDENTIFICATION

NOTE — See Factory Installed Options Selection on Next Page For Complete Description Of Available Accessories.
 NOTE — This example shows all possible combinations available.

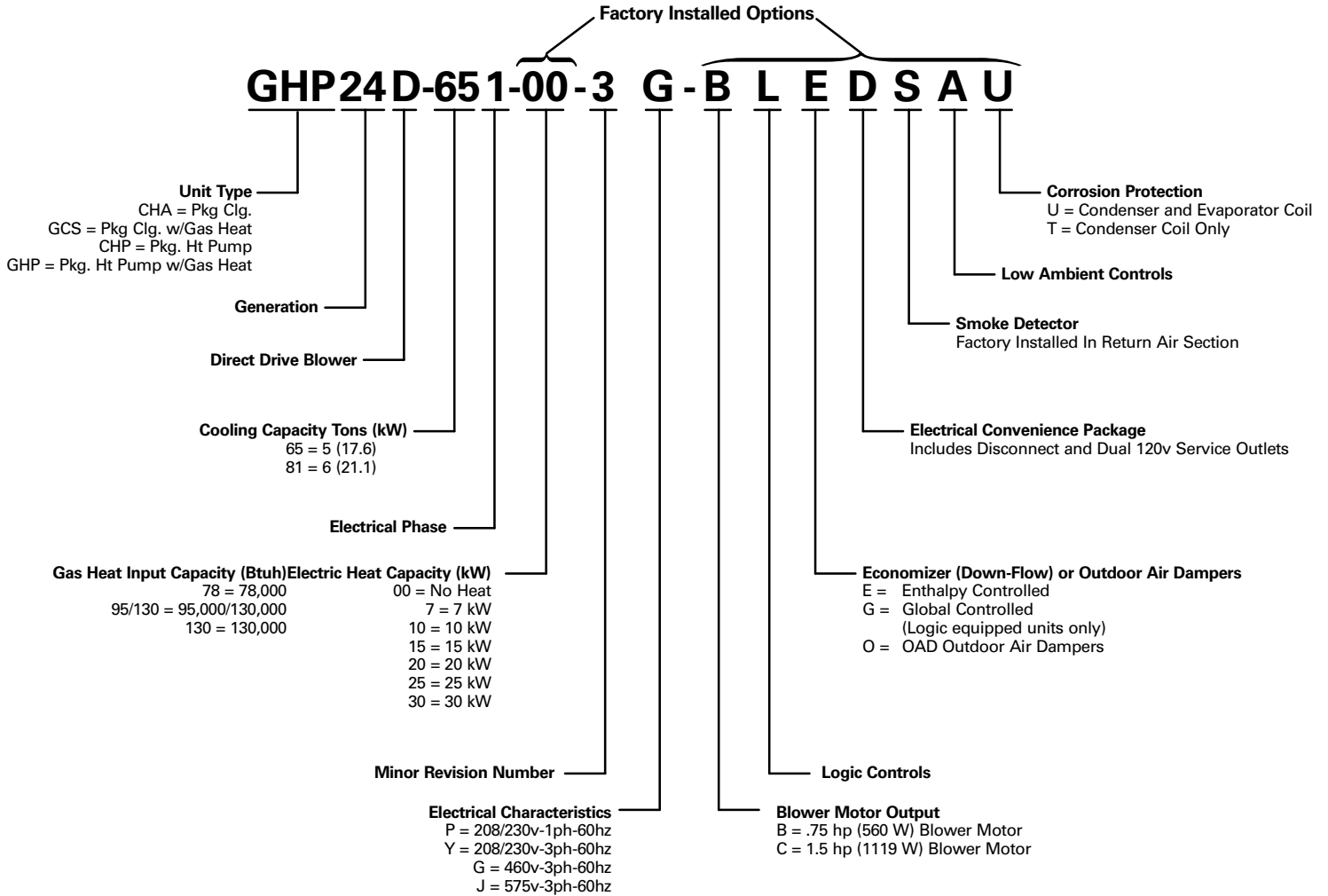

FACTORY INSTALLED OPTIONS SELECTION

GHP24D-651-653

Packaged Unit Model No.	Voltage Selection 1 or 3 phase 60hz	Electrical Convenience Package (D)	Low Ambient Controls (A)
GHP24D-651-653 Basic unit includes: -.75 hp (560W) Blower Motor -Hinged Control Box -Hinged Filter Access -Bottom Power Entry	208/230v	Unit Disconnect Installed and Wired. Dual 120v GFCI Service Outlets, (Field Wired)	Low Ambient Controls (Down to 30°F (-1.1°C) Operation) Installed and Wired
	460V		
	575v		

GHP24D-651-653 (Continued)

Packaged Unit Model No.	Outdoor Air Damper (O)	Economizer Package (E) or (G)	Smoke Detector Package (S)	Corrosion Protection Package (T) or (U)
GHP24D-651-653 Basic unit includes: -.75 hp (560W) Blower Motor -Hinged Control Box -Hinged Filter Access -Bottom Power Entry	Linked Damper Assembly and Outdoor Air Hood Installed	Economizer With Gravity Exhaust Installed and Wired (E) Enthalpy Controlled or (G) Globally Controlled	Photoelectric Smoke Detector Installed and Wired In Return Air Section	Corrosion Resistant Coating Applied To Both Condenser And Evaporator Coil With Painted Base in Condensing And Evaporator Section And Painted Blower Housing (U) Or Condenser Coil Only With Painted Base Condensing Section(T)

All MODELS

Packaged Unit Model No.	Logic Controls Package (L)
All Models	Controls for Logic control system factory installed

COOLING AND HEATING RATINGS

NOTE — For Temperatures and Capacities not shown in tables, see bulletin — Cooling Unit Rating Table Correction Factor Data in Miscellaneous Engineering Data section.

GHP24D-651-653 COOLING CAPACITY

Entering Wet Bulb Temperature	Total Air Volume		Outdoor Air Temperature Entering Outdoor Coil																							
			85°F (29°C)						95°F (35°C)						105°F (41°C)						115°F (46°C)					
			Total Cooling Capacity		Compressor Motor Watts Input	Sensible To Total Ratio (S/T) Dry Bulb			Total Cooling Capacity		Compressor Motor Watts Input	Sensible To Total Ratio (S/T) Dry Bulb			Total Cooling Capacity		Compressor Motor Watts Input	Sensible To Total Ratio (S/T) Dry Bulb			Total Cooling Capacity		Compressor Motor Watts Input	Sensible To Total Ratio (S/T) Dry Bulb		
			kW	Btuh		75°F 24°C	80°F 27°C	85°F 29°C	kW	Btuh		75°F 24°C	80°F 27°C	85°F 29°C	kW	Btuh		75°F 24°C	80°F 27°C	85°F 29°C	kW	Btuh		75°F 24°C	80°F 27°C	85°F 29°C
63°F (17.2°C)	875	1850	17.7	60,300	4910	.71	.88	1.00	16.9	57,600	5310	.73	.90	1.00	16.1	55,000	5720	.74	.93	1.00	15.3	52,300	6130	.77	.95	1.00
	990	2100	18.1	61,600	4950	.74	.92	1.00	17.3	58,900	5360	.76	.95	1.00	16.5	56,300	5770	.79	.97	1.00	15.7	53,600	6200	.81	.99	1.00
	1110	2350	18.4	62,800	4980	.78	.96	1.00	17.6	60,200	5400	.80	.98	1.00	16.9	57,500	5830	.83	1.00	1.00	16.1	55,000	6280	.85	1.00	1.00
67°F (19.4°C)	875	1850	18.8	64,000	5010	.55	.69	.84	17.9	61,100	5440	.56	.70	.86	17.1	58,200	5860	.57	.72	.89	16.2	55,300	6290	.58	.74	.92
	990	2100	19.0	65,000	5040	.57	.72	.89	18.2	62,100	5470	.58	.74	.91	17.3	59,100	5900	.59	.76	.94	16.5	56,200	6340	.60	.78	.97
	1110	2350	19.3	65,900	5070	.59	.75	.93	18.4	62,900	5500	.60	.78	.96	17.6	60,000	5940	.61	.80	.98	16.7	56,900	6380	.63	.83	1.00
71°F (21.7°C)	875	1850	20.0	68,200	5140	.41	.54	.66	19.1	65,200	5580	.41	.54	.68	18.2	62,200	6030	.41	.55	.70	17.3	59,100	6490	.42	.57	.71
	990	2100	20.3	69,200	5160	.41	.56	.70	19.4	66,200	5620	.42	.57	.71	18.5	63,000	6070	.42	.58	.73	17.6	59,900	6530	.43	.59	.76
	1110	2350	20.5	70,100	5190	.42	.58	.73	19.6	67,000	5640	.42	.59	.75	18.7	63,800	6100	.43	.60	.77	17.7	60,500	6570	.44	.62	.80

NOTE — All values are gross capacities and do not include indoor coil blower motor heat deduction.

GHP24D-651-653 HEATING CAPACITY

Indoor Coil Air Volume 70°F db (21°C db)	Air Temperature Entering Outdoor Coil																			
	65°F (18°C)				45°F (7°C)				25°F (-4°C)				5°F (-15°C)				-15°F (-28°C)			
	Total Heating Capacity		Comp. Motor Watts Input	Total Heating Capacity		Comp. Motor Watts Input	Total Heating Capacity		Comp. Motor Watts Input	Total Heating Capacity		Comp. Motor Watts Input	Total Heating Capacity		Comp. Motor Watts Input					
	L/s	cfm		kW	Btuh		kW	Btuh		kW	Btuh		kW	Btuh		kW	Btuh			
825	1750	21.1	72,000	4950	16.8	57,400	4335	10.6	36,300	3500	6.6	22,600	2760	3.3	11,200	2105				
945	2000	21.3	72,800	4815	17.1	58,200	4200	10.9	37,100	3365	6.9	23,400	2625	3.5	12,000	1970				
1060	2250	21.6	73,800	4710	17.3	59,200	4095	11.2	38,100	3260	7.2	24,400	2520	3.8	13,000	1865				

NOTE — Heating capacities include the effect of defrost cycles in the temperature range where they occur.

GHP24D-651-653 HEATING PERFORMANCE at 2000 cfm (945 L/s) Indoor Coil Air Volume

*Outdoor Temperature		Compressor Motor Watts Input	Total Output	
°F	°C		Btuh	kW
65	18	4815	72,800	21.3
60	16	4665	69,400	20.3
55	13	4515	66,100	19.4
50	10	4370	62,700	18.4
47	8	4280	60,700	17.8
45	7	4200	58,200	17.1
40	4	4000	52,000	15.2
35	2	3800	45,700	13.4
30	-1	3580	41,400	12.1
25	-4	3365	37,100	10.9
20	-7	3145	32,900	9.6
17	-8	3015	30,300	8.9
15	-9	2950	29,200	8.6
10	-12	2785	26,300	7.7
5	-15	2625	23,400	6.9
0	-18	2460	20,600	6.0
-5	-21	2295	17,700	5.2
-10	-23	2135	14,800	4.3
-15	-26	1970	12,000	3.5
-20	-29	1810	9100	2.7

*Outdoor temperature at 70% relative humidity. Indoor temperature at 70°F (21°C).

BLOWER DATA

GHP24D-651-653 BLOWER PERFORMANCE @ 208 VOLTS (With Down-Flo Supply and Return Air Openings)

External Static Pressure		Air Volume at Various Blower Speeds									
		High		Medium-High		Medium		Medium-Low		Low	
in. w.g.	Pa	cfm	L/s	cfm	L/s	cfm	L/s	cfm	L/s	cfm	L/s
0	0	2530	1195	2265	1070	1970	930	1720	810	1440	680
.10	25	2495	1175	2235	1055	1945	920	1700	800	1430	675
.20	50	2450	1155	2200	1040	1915	905	1670	790	1415	670
.30	75	2405	1135	2160	1020	1880	890	1640	775	----	----
.40	100	2355	1110	2115	1000	1840	870	1605	755	----	----
.50	125	2300	1085	2065	975	1795	845	1565	740	----	----
.60	150	2235	1055	2010	950	1745	825	1515	715	----	----
.70	175	2165	1020	1945	920	1690	800	1460	690	----	----
.80	200	2090	985	1875	885	1620	765	1400	660	----	----
.90	225	2000	945	1790	845	1550	730	----	----	----	----
1.00	250	1895	895	1695	800	1460	690	----	----	----	----
1.10	275	1770	835	1580	745	----	----	----	----	----	----
1.20	300	1620	765	1440	680	----	----	----	----	----	----

NOTE — All air data is measured external to unit with dry coil and 2 inch (51 mm) filters. See Page 12 for Accessory Air Resistance Table.

BLOWER DATA

GHP24D-651-653 BLOWER PERFORMANCE @ 230 VOLTS (With Down-Flo Supply and Return Air Openings)

External Static Pressure		Air Volume at Various Blower Speeds									
		High		Medium-High		Medium		Medium-Low		Low	
in. w.g.	Pa	cfm	L/s	cfm	L/s	cfm	L/s	cfm	L/s	cfm	L/s
0	0	2750	1300	2500	1180	2245	1060	1955	925	1630	770
.10	25	2705	1275	2470	1165	2215	1045	1925	910	1600	755
.20	50	2650	1250	2430	1145	2180	1030	1890	890	1570	740
.30	75	2585	1220	2390	1130	2140	1010	1850	875	1535	725
.40	100	2535	1195	2340	1105	2100	990	1810	855	1500	710
.50	125	2475	1170	2290	1080	2050	965	1760	830	1455	685
.60	150	2405	1135	2225	1050	1995	940	1705	805	1405	665
.70	175	2330	1100	2155	1015	1930	910	1640	775	-----	-----
.80	200	2245	1060	2075	980	1865	880	1575	745	-----	-----
.90	225	2155	1015	1975	930	1780	840	1495	705	-----	-----
1.00	250	2050	965	1860	880	1690	800	1405	665	-----	-----
1.10	275	1935	915	1720	810	1585	750	-----	-----	-----	-----
1.20	300	1805	850	1560	735	1450	685	-----	-----	-----	-----

NOTE — All air data is measured external to unit with dry coil and 2 inch (51 mm) filters. See below for Accessory Air Resistance Table.

GHP24D-651-653 BLOWER PERFORMANCE @ 460/575 VOLTS (With Down-Flo Supply and Return Air Openings)

External Static Pressure		Air Volume at Various Blower Speeds					
		High		Medium		Low	
in. w.g.	Pa	cfm	L/s	cfm	L/s	cfm	L/s
0	0	2820	1330	2460	1160	1975	930
.10	25	2770	1305	2430	1145	1950	920
.20	50	2720	1285	2395	1130	1920	905
.30	75	2670	1260	2345	1105	1885	890
.40	100	2610	1230	2310	1090	1845	870
.50	125	2545	1200	2260	1065	1800	850
.60	150	2475	1170	2200	1040	1755	830
.70	175	2400	1130	2140	1010	1700	800
.80	200	2315	1090	2065	975	1635	770
.90	225	2220	1045	1980	935	1565	740
1.00	250	2115	1000	1880	885	1480	700
1.10	275	2000	945	1760	830	-----	-----
1.20	300	1860	875	1615	760	-----	-----

NOTE — All air data is measured external to unit with dry coil and 2 inch (51 mm) filters. See below for Accessory Air Resistance Table.

ACCESSORY AIR RESISTANCE

Air Volume		Total Resistance — inches water gauge (Pa)					
		Wet Indoor Coil	REMD24M Down-flo Economizer	RTD11 Step-Down Diffuser			FD11 Flush Diffuser
cfm	L/s			2 Ends Open	1 Side 2 Ends Open	All Ends & Sides Open	
1800	850	.06 (15)	.11 (27)	.13 (32)	.11 (27)	.09 (22)	.09 (22)
2000	945	.07 (17)	.12 (30)	.15 (37)	.13 (32)	.11 (27)	.10 (25)
2200	1040	.09 (22)	.14 (35)	.18 (45)	.15 (37)	.12 (30)	.12 (30)
2400	1135	.11 (27)	.16 (40)	.21 (52)	.18 (45)	.15 (37)	.14 (35)
2600	1225	.13 (32)	.18 (45)	.24 (60)	.21 (52)	.18 (45)	.17 (42)
2800	1320	.16 (40)	.20 (50)	.27 (67)	.24 (60)	.21 (52)	.20 (50)
3000	1415	.20 (50)	.23 (57)	.32 (80)	.29 (72)	.25 (62)	.25 (62)

CEILING DIFFUSER AIR THROW DATA

Unit Model No.	Air Volume		*Effective Throw Range			
			RTD11 Step-Down		FD11 Flush	
	cfm	L/s	ft.	m	ft.	m
GHP24D-651-653	3000	1415	27 — 33	8 — 10	25 — 30	8 — 9
	3375	1595	30 — 37	9 — 11	28 — 34	9 — 10
	3750	1770	34 — 41	10 — 12	31 — 38	9 — 12

*Throw is the horizontal or vertical distance an airstream travels on leaving the outlet or diffuser before the maximum velocity is reduced to 50 ft. (15 m) per minute. Four sides open.

GUIDE SPECIFICATIONS

Prepared for the guidance of architects, consulting engineers and mechanical contractors.

General — Furnish and install a single package dual fuel heat pump complete with automatic controls. The single package unit shall be a standard product of a firm regularly engaged in the manufacture of heating-cooling equipment. The manufacturer shall have parts and service available throughout the U.S. and Canada.

The installed weight shall not be more than lbs.(kg). Entire unit shall have a width of not more than inches (mm), a depth of not more than inches (mm) and an overall height of not more than inches (mm). The equipment shall be shipped completely factory assembled, precharged, piped and wired internally ready for field connections. In addition, manufacturer shall test operate system at the factory before shipment.

Approvals — All electrical components shall have U.L. and C.G.A. Listing. All wiring shall be in compliance with NEC and CEC.

Equipment Warranty — Heat exchangers have a limited warranty for a full ten years. Compressors have a limited warranty for a full five years. All other components have a limited warranty for one year. Refer to the Lennox Equipment Limited Warranty certificate included with the unit for details.

Air Distribution — Equipment shall be capable of bottom or side (horizontal) handling of conditioned air. All air distribution ducts shall be fiberglass or ga. galvanized steel insulated with inch (mm) thick lb./ft.³ (kg/m³) density fiberglass or equivalent.

Cooling System — The total certified cooling capacity shall not be less than Btuh (kW) with an indoor coil air volume of cfm (L/s), an entering wet bulb air temperature of °F (°C), an entering dry bulb air temperature of °F (°C) and an outdoor coil entering temperature of °F (°C). The compressor power input shall not exceed kW at these conditions.

Heating System — The total certified heating capacity shall not be less than Btuh (kW) with an indoor coil air volume of cfm (L/s), an entering wet bulb air temperature of °F (°C), an entering dry bulb air temperature of °F (°C) and an outdoor coil entering temperature of °F (°C). The compressor power input shall not exceed kW at these conditions.

The coils shall be non-ferrous construction with aluminum enhanced fins mechanically bonded to copper tubes. Indoor coil shall have rifled tubes. Coils shall be pressure leak tested. Coil face area shall be not less than sq. ft. (m²) (indoor coil) and sq. ft. (m²) (outdoor coil). Sloped drain pan shall provide positive drainage of condensate.

Compressor shall be resiliently mounted and have overload protection and crankcase heater. The refrigeration system shall have suction and liquid line service gauge ports, high pressure switch, loss of charge switch, defrost control, check and expansion valve, reversing valve, suction line accumulator, thermometer well, drier, freestat and full refrigerant charge. Control option available shall consist of low ambient control (factory or field installed) and timed-off control (field installed). Shall be rated in accordance with ARI Standard 210/240-89, and DOE test procedures.

Gas Heating System — The heating capacity output shall be Btuh (kW) with a gas input of Btuh (kW).

Tubular heat exchanger and inshot type gas burners shall be constructed of aluminized steel. Controls shall consist of direct spark ignition, electronic flame sensor controls, flame rollout switch, limit control(s), automatic redundant gas valve and blower prove switch on induced draft blower. All models shall have dual gas valve with staging control. Unit shall be available for use with LPG/propane as an option. Complete service access shall be provided for controls and wiring. Shall be U.L. and C.G.A. design certified for outdoor installation.

Cabinet — Shall be galvanized steel with a powdered enamel paint finish electrostatically bonded to the metal. Cabinet panels where conditioned air is handled shall be fully insulated to prevent sweating and minimize sound. Openings shall be provided for power entry in bottom and side of unit. Indoor coil condensate drain shall extend outside of cabinet. Lifting holes shall be provided for rigging.

Service Access — All components, wiring and inspection areas shall be completely accessible through removable panels. Outdoor coil compartment wall shall have access holes for service gauge line pass-through.

Supply Air Blower — Centrifugal supply air blower shall be driven by a multi-speed direct drive motor and be capable of delivering cfm (L/s) at an external static pressure of inches water gauge (Pa) requiring not more than bhp (W) and rpm. Blower shall be statically and dynamically balanced.

Outdoor Coil Fan — Direct drive propeller type outdoor coil fan shall discharge vertically and be direct driven by a hp (W) motor. Fan motor shall be permanently lubricated and inherently protected. Fan shall have a safety guard.

Air Filters — Disposable filters furnished shall have not less than sq. ft. (m²) of free area.

OPTIONAL ACCESSORIES (Must Be Ordered Extra)

Roof Mounting Frame — Furnish and install a steel roof mounting frame for bottom discharge and return air duct connection. It shall mate to the bottom perimeter of the equipment. When flashed into the roof it shall make a unit mounting curb and provide weatherproof duct connection and entry into the conditioned area. Flashing shall be the responsibility of a roofing contractor. Frame design shall be approved by U.S. National Roofing Contractors Association.

Supply and Return Air Transitions — Supply and return transitions shall be available, for field installation in the roof mounting frame, to facilitate duct connection to the diffuser.

Ceiling Diffusers — Furnish and install a (flush or stepdown) optional combination ceiling supply and return air diffuser. It shall be capable of not less than ft. (m) radius of effective throw.

Economizer Dampers — Furnish and install complete with controls an air mixing damper assembly including outdoor air and recirculated air dampers. The assembly shall provide for the introduction of outside air for minimum ventilation and free cooling. Damper motor shall be 24 volt fully modulating spring return. Controls shall include electronic discharge air sensor, minimum position potentiometer, and solid-state adjustable enthalpy control. Control option available shall consist of differential enthalpy control (return air sensor). Economizer shall include pressure operated gravity exhaust dampers. Damper blades shall ride in nylon bearings and be gasketed for tight seal and quiet operation. Exhaust dampers shall install in return air duct for horizontal applications. Economizer shall be available for factory or field installation.

Outdoor Air Damper Section — Optional outdoor dampers shall be available to provide outdoor air requirements of up to 25%. Damper section factory or field installs on unit cabinet. Shall be equipped with outdoor air hood with bird screen protection. Shall be available for manual or motorized operation.

Horizontal Supply & Return Air Kit — Optional kit shall provide necessary cabinet parts to field convert unit for side (horizontal) supply and return air duct connections.

Control Systems — Shall provide a selection of thermostats and related controls to automatically operate the mechanical equipment through the heating or cooling and ventilating cycles as required.

Disconnect Package — Furnish and factory install package that includes unit disconnect and dual 120 volt GFCI type service outlets

Smoke Detector Package — Furnish and factory install photoelectric type smoke detector in return air section.

Corrosion Protection Package — Furnish and factory apply phenolic epoxy coating to condenser and evaporator coils with painted condensing and evaporator base sections and painted blower housing or apply only to condenser coil with painted condensing section base.

DIMENSIONS — inches (mm)

GHP24 BASIC UNIT

CORNER WEIGHTS — lbs. (kg)

Model No.	AA		BB		CC		DD	
	lbs.	kg	lbs.	kg	lbs.	kg	lbs.	kg
GHP24(D)-650	140	64	151	68	231	105	214	97

CENTER OF GRAVITY — in. (mm)

Model No.	EE		FF	
	in.	mm	in.	mm
GHP24(D)-650	18-1/2	470	43	1092

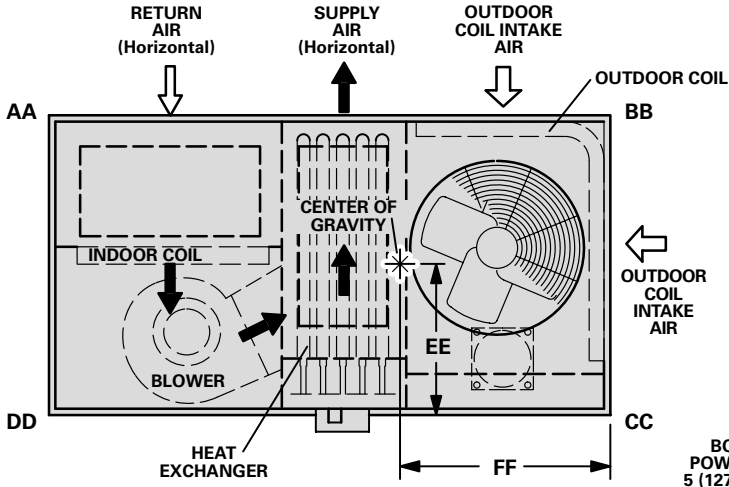

TOP VIEW

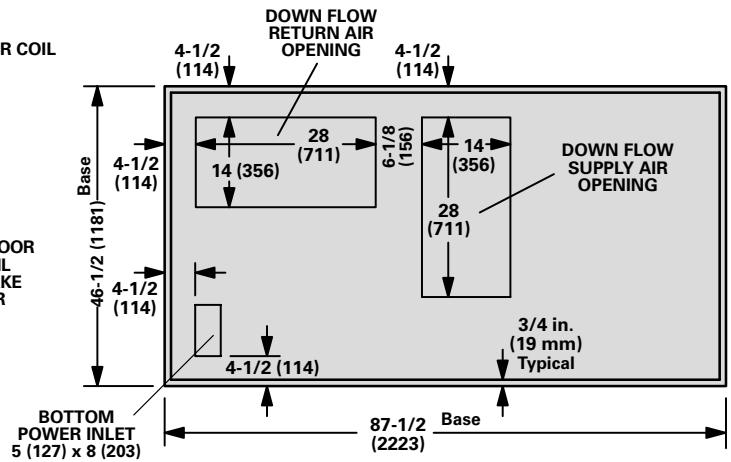

TOP VIEW BASE SECTION

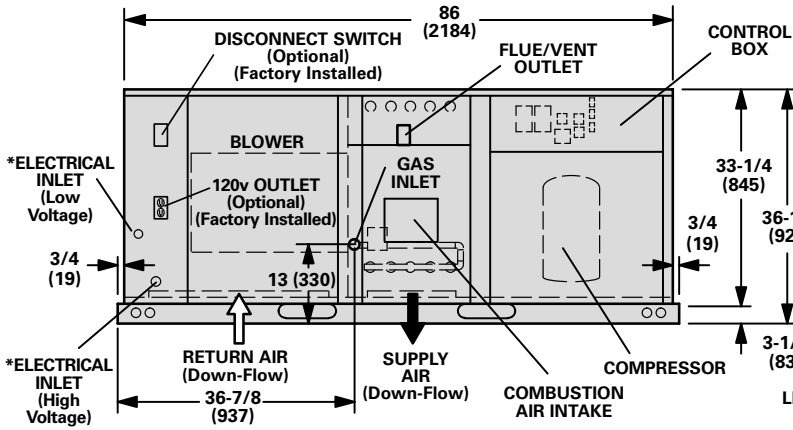

FRONT VIEW

*When Factory Installed Disconnect is Not Used.

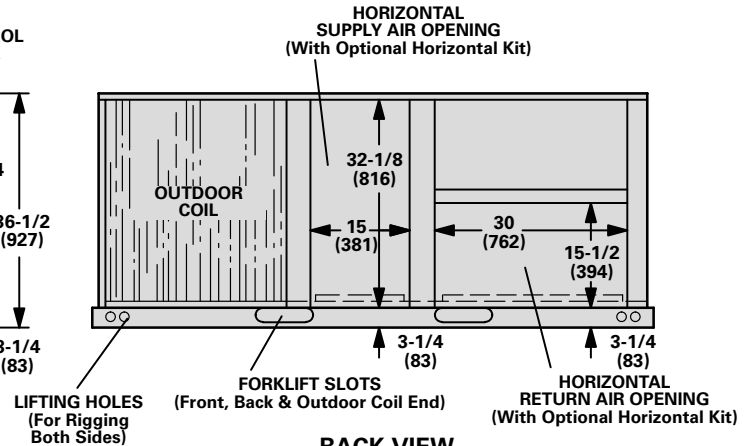

BACK VIEW

With Horizontal Supply & Return Air Openings (Optional Horizontal Kit Required)

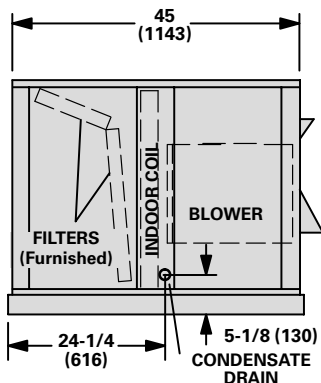

LEFT END VIEW

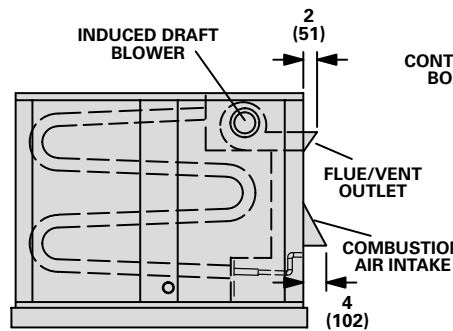

LEFT END VIEW HEAT SECTION

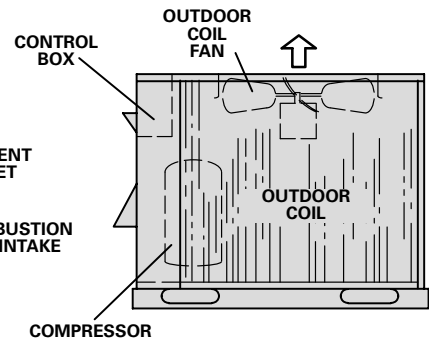

RIGHT END VIEW OUTDOOR COIL END

ACCESSORY DIMENSIONS – inches (mm)

**GHP24 UNIT WITH REMD24M-81 ECONOMIZER DAMPER SECTION
AND RMF24-81 ROOF MOUNTING FRAME
(DOWN-FLOW APPLICATION)**

CORNER WEIGHTS – lbs. (kg)

Model No.	AA		BB		CC		DD	
	lbs.	kg	lbs.	kg	lbs.	kg	lbs.	kg
GHP24D-650	160	73	163	74	239	108	230	104

CENTER OF GRAVITY – in. (mm)

Model No.	EE		FF	
	in.	mm	in.	mm
GHP24D-650	19	483	43-1/2	1105

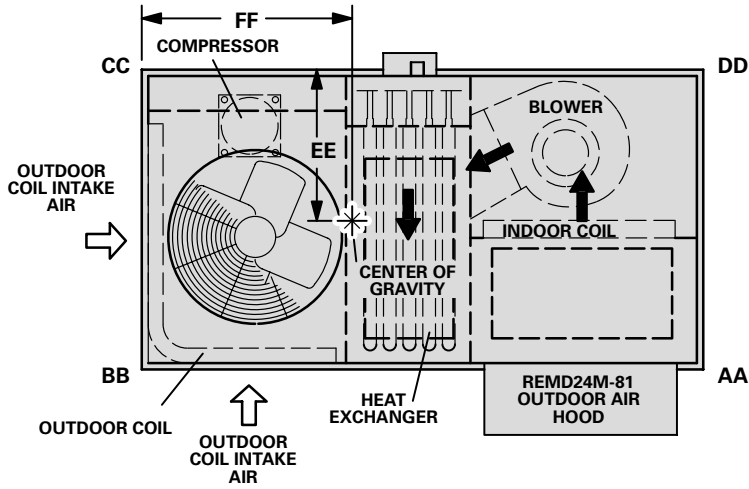

TOP VIEW

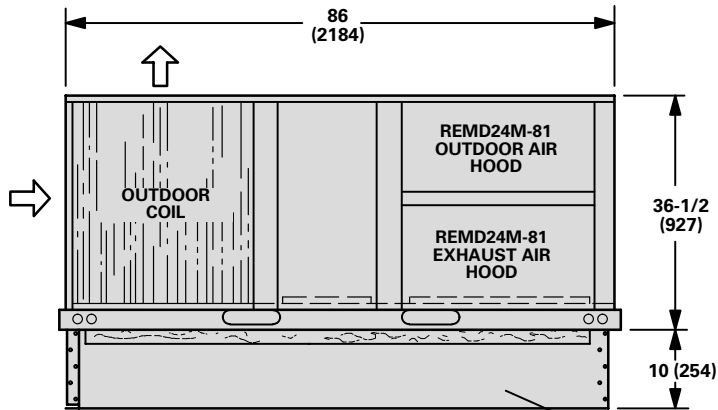

BACK VIEW

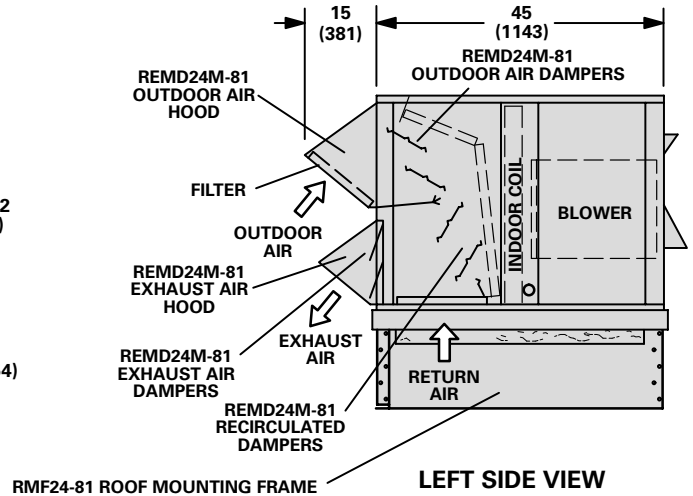

LEFT SIDE VIEW

**GHP24 UNIT WITH REMD24M-81 ECONOMIZER DAMPER SECTION
(HORIZONTAL APPLICATION)**

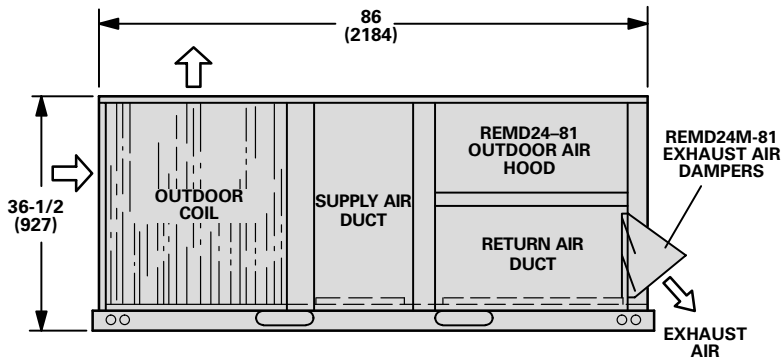
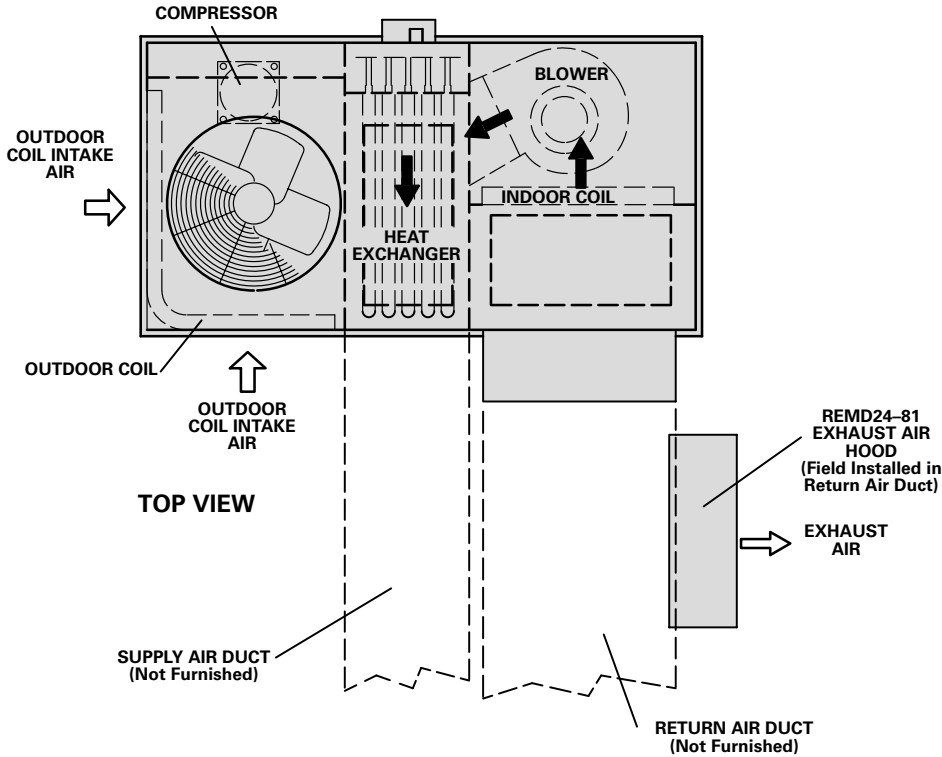

BACK VIEW
With Horizontal Supply & Return Air Openings

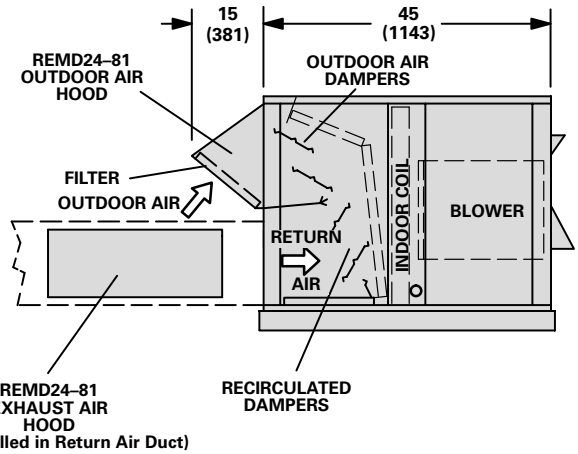

LEFT SIDE VIEW

ACCESSORY DIMENSIONS — inches (mm)

RMF24-81 ROOF MOUNTING FRAME WITH DOUBLE DUCT OPENING

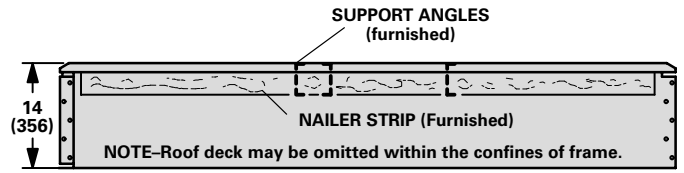
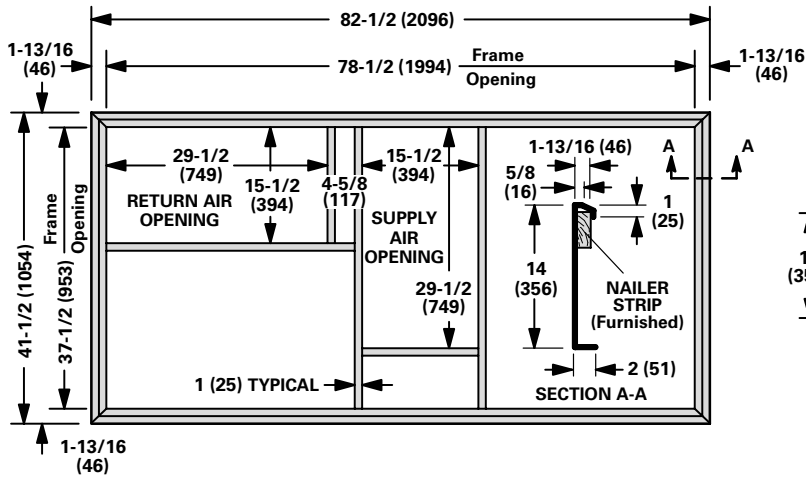

RMF24-81 ROOF MOUNTING FRAME WITH SRT24-81 SUPPLY AND RETURN TRANSITIONS FOR FD11-95 & RTD11-95 CEILING DIFFUSERS

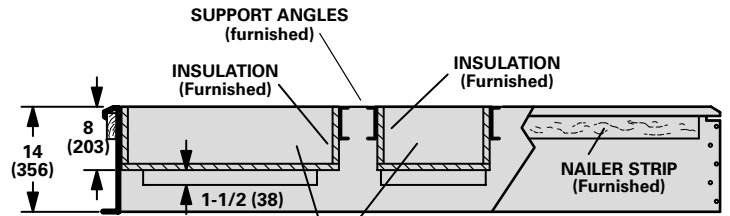
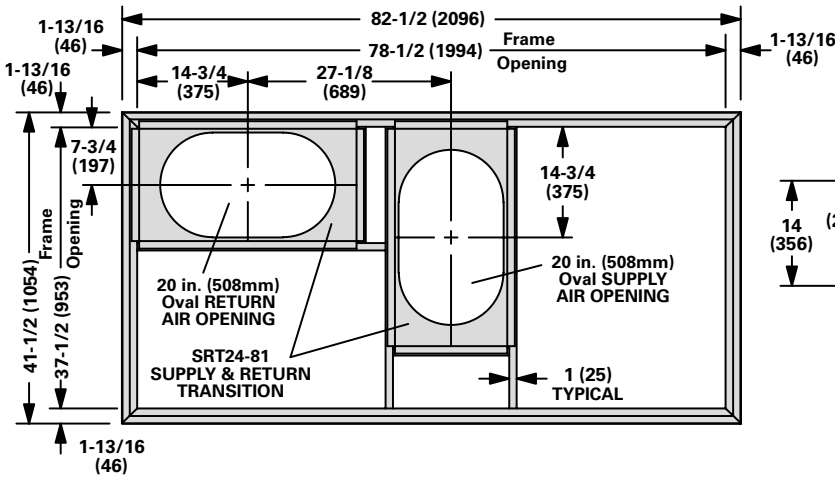

SRT24-81 CEILING SUPPLY AND RETURN AIR TRANSITION
(See Drawing Above For Additional Dimensions)

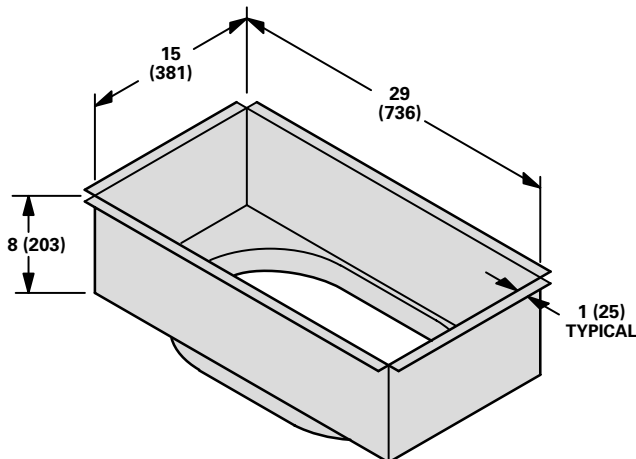

TYPICAL FLASHING DETAIL FOR RMF24 ROOF MOUNTING FRAME

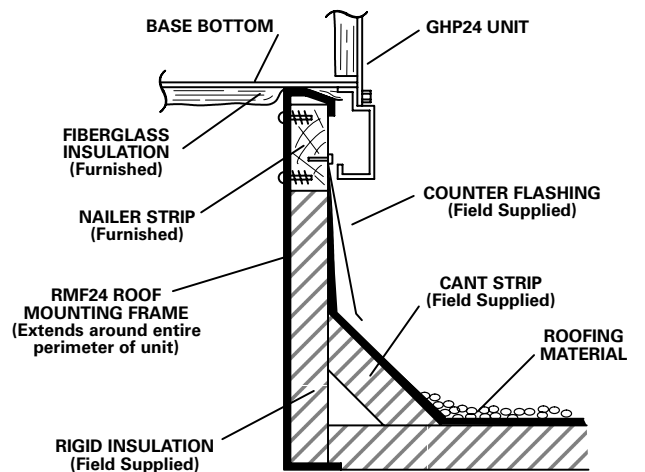

RMF24-81 SERIES ROOF MOUNTING FRAME WITH DOUBLE DUCT OPENING

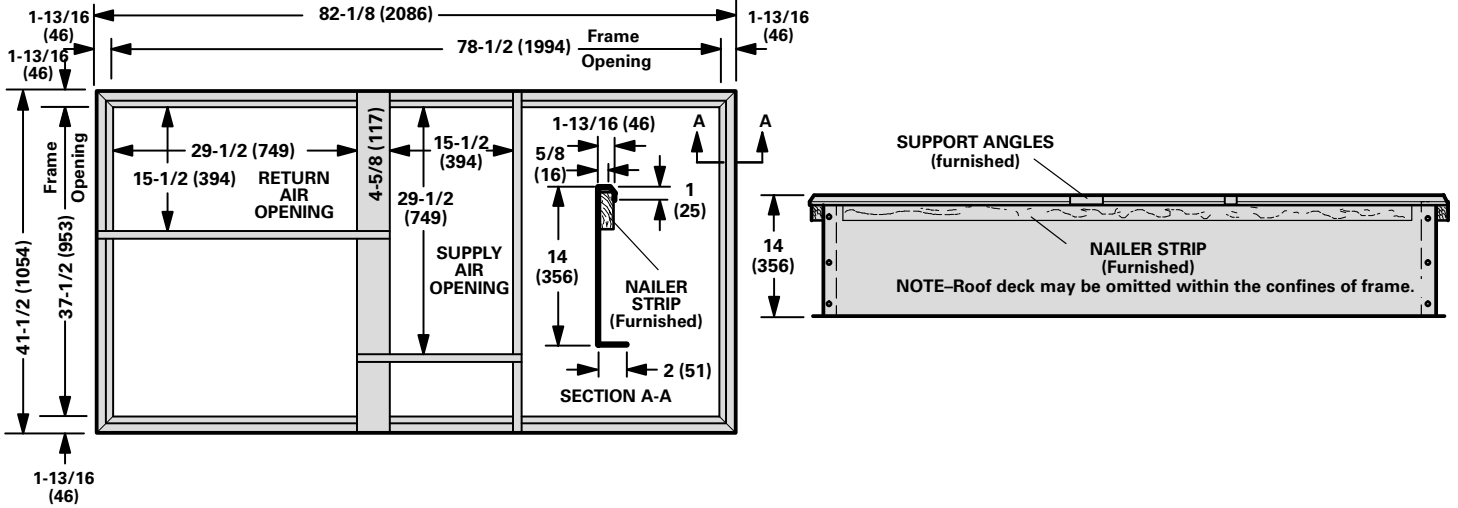

RMF24-81 ROOF MOUNTING FRAMES WITH SRT24-81 SUPPLY AND RETURN AIR TRANSITIONS FOR FD11-95 & RTD11-95 CEILING DIFFUSERS

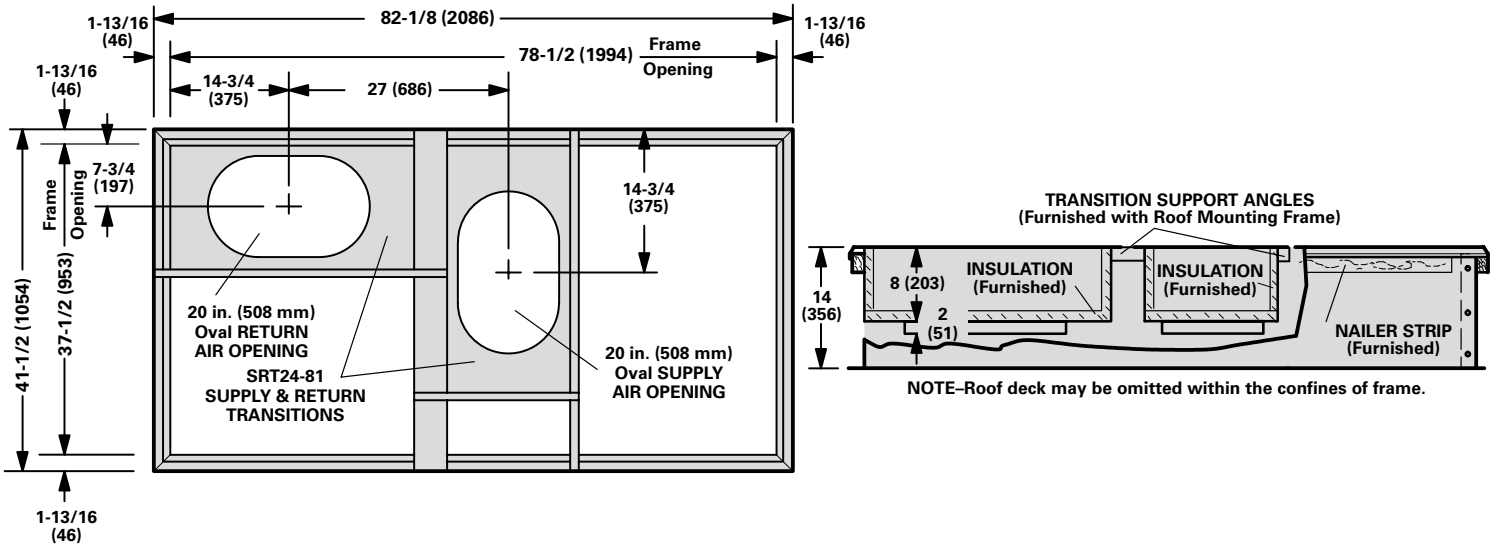

ACCESSORY DIMENSIONS – inches (mm)

**GHP24 UNIT WITH OAD24 OUTDOOR DAMPER SECTION
(For Down-Flo or Horizontal Supply and Return Air Applications)**

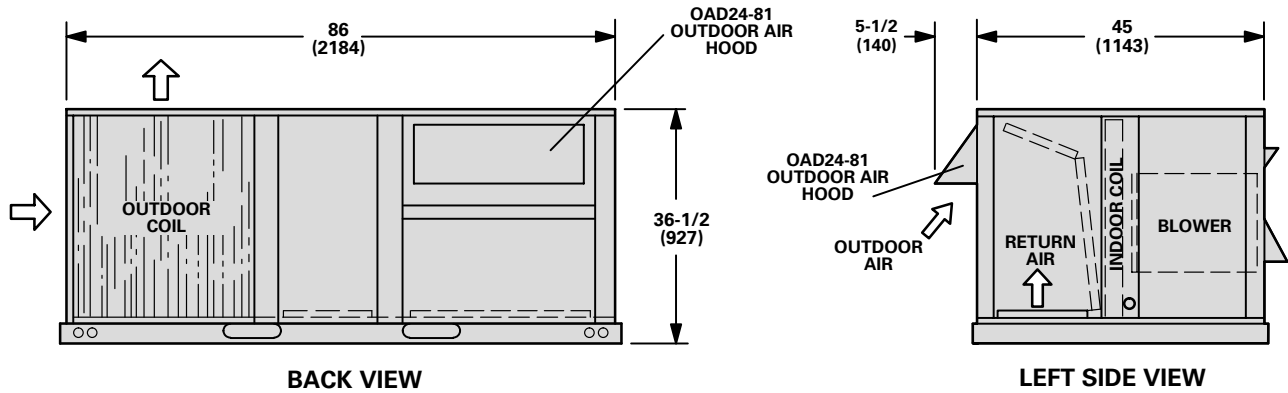

COMBINATION CEILING SUPPLY AND RETURN DIFFUSERS

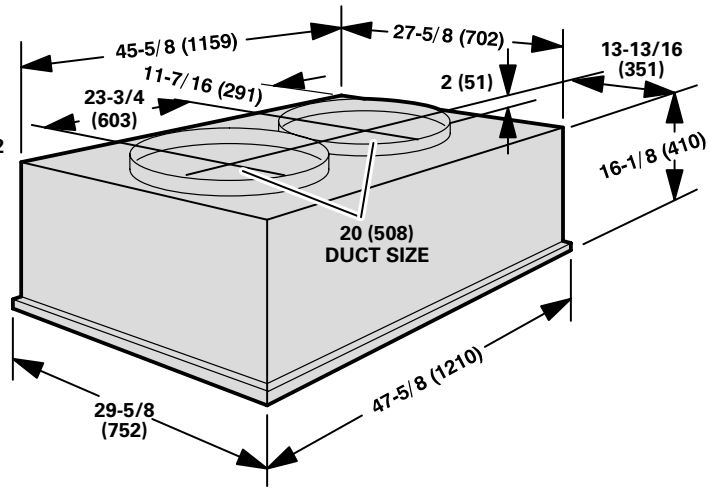
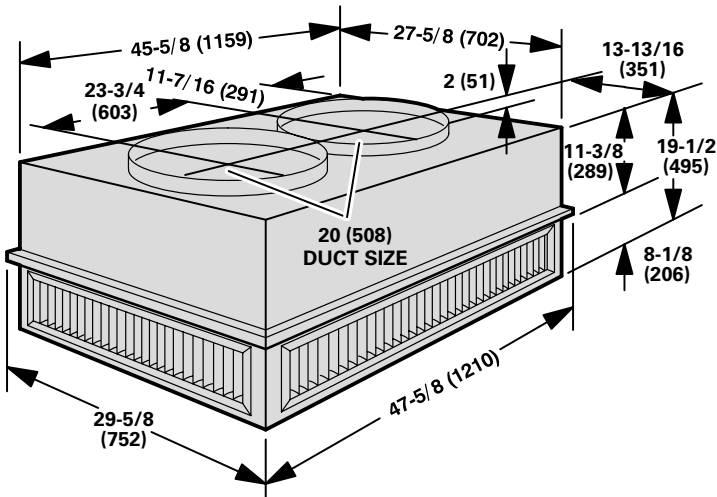

INSTALLATION CLEARANCES – inches (mm)

GHP24 BASIC UNIT

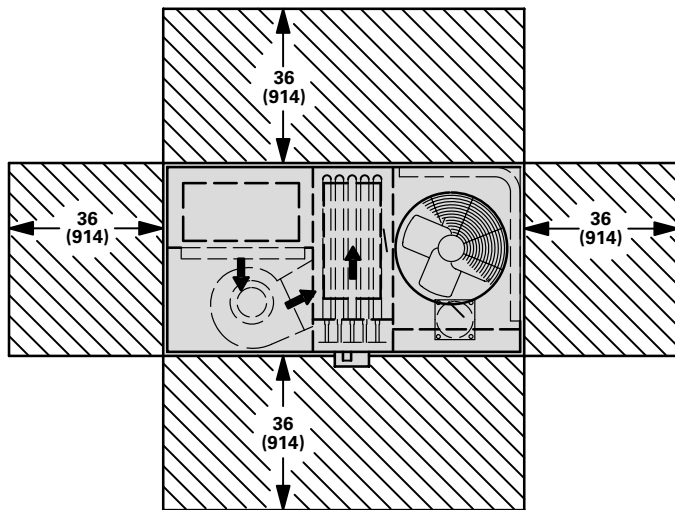

NOTE – Top Clearance Unobstructed.

GHP24 UNIT WITH REMD24M ECONOMIZER DAMPER SECTION OR OAD24 OUTDOOR AIR DAMPER SECTION

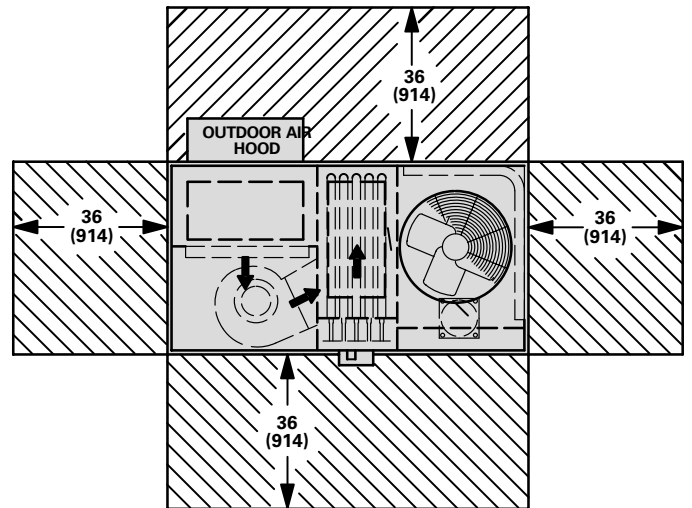

NOTE – Top Clearance Unobstructed.