



PRODUCT SPECIFICATIONS

Bulletin No. 210652
 March 2018
 Supersedes October 2013



AFUE - 90%

Input - 50,000 to 100,000 Btuh

MODEL NUMBER IDENTIFICATION

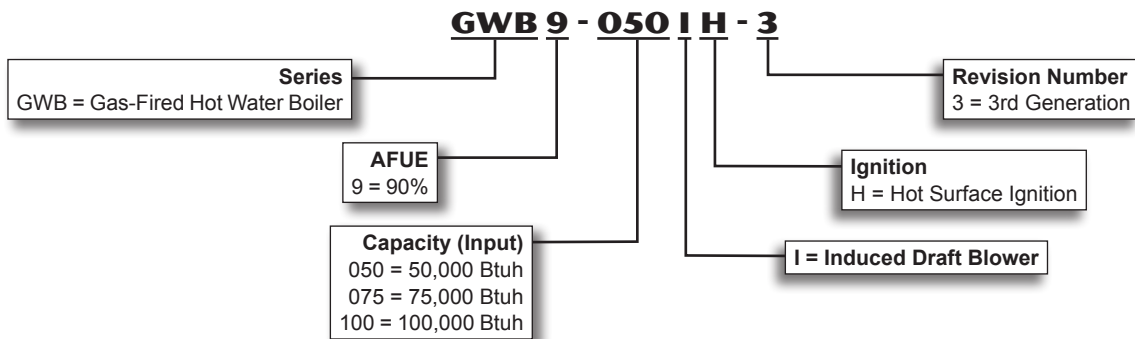

FEATURES

CONTENTS

Circulating Pump Flow Rate 8
 Dimensions 6
 Features 1
 High Altitude Derate 5
 Installation Clearances 4
 Intake/Exhaust Pipe Vent Lengths 4
 Model Number Identification 1
 Optional Accessories 4
 Optional Accessory Dimensions 7
 Specifications 4

WARRANTY

Cast aluminum boiler assembly - Limited fifteen year warranty in residential applications only.

All other covered components - Limited ten years warranty in residential applications.

Refer to Lennox Equipment Limited Warranty certificate included with equipment for details.

FEATURES

APPROVALS

Low pressure, sectional cast aluminium boilers are design certified by CSA for use with natural gas or LPG/Propane.

Annual Fuel Utilization Efficiencies are based on US DOE test procedures and FTC labeling regulations.

Units are certified by AHRI.

Boiler heat exchanger assemblies are constructed and hydrostatically tested in accordance with American Society of Mechanical Engineers (ASME) Boiler and Pressure Vessel Code Section IV Standards for heating boilers.

ENERGY STAR® certified units are designed to use less energy, help save money on utility bills, and help protect the environment.

APPLICATIONS

Heating input capacities of 50,000, 75,000 and 100,000 Btuh.

AFUE of 90%.

Hot surface ignition.

Natural gas or LPG/Propane (LPG with optional conversion kit).

Boiler applications include radiant floor heating, baseboard heating and zoned heating systems. For use in closed hydronic heating system only.

Compact size allows easy installation in a basement or utility room.

All units are completely factory assembled with all controls installed and wired.

Each unit is factory test operated to ensure dependable performance.

HEATING SYSTEM

Cast Aluminum Boiler Assembly

Boiler sections are constructed of long life cast aluminum.

Push nipples are constructed of wrought aluminum.

Boiler sections and push nipples expand and contract together, providing positive watertight seal.

Sightglass is furnished for flame viewing.

Hot Surface Igniter

Tough, reliable, long-life, trouble-free performance.

Silicon nitride ignitor.

Automatic Gas Control

24 volt redundant combination gas control valve combines 100% safety shut-off, manual shut off valve (On-Off), automatic electric valve and gas pressure regulation into a compact combination control.

Stainless Steel Premix Inshot Burner

Inshot burner provides efficient, trouble-free operation.

Burner mixes air and gas in correct proportion for proper combustion.

Induced Draft Blower

Heavy-duty blower safely vents flue products.

Differential pressure switch prevents unit operation in case of flue blockage of intake or exhaust air.

Pressure switch controlled by Integrated Boiler Control Module for a pre-purge and a post purge cycle.

Pressure switch proves blower operation before allowing gas valve to open. After five minutes of lack of adequate differential pressure, the control will lockout unit operation.

Blower operates only during heating cycle.

Adjustable exhaust vent (front, right side or rear).

Circulating Pump

Furnished standard for field installation at the installer's preferred location.

Relief Valve and Air Vent

Furnished as standard for field installation in top of cabinet.

Valve provides for pressure relief of heating system in case of abnormal operating conditions.

Valve opens at 30 psig and is approved by ASME.

Combination Temperature/Pressure Gauge

Located on supply piping.

Gauge monitors system for safe and reliable operation.

Brass Drain Valve

Factory installed 3/4 in. brass drain valve is furnished in the first boiler section.

Optional Accessories

LPG/Propane Conversion Kit

Required for field changeover from natural gas to LPG/Propane. See Specifications table.

DIRECT VENT SEALED COMBUSTION SYSTEM

Boiler features a "sealed combustion" system and can only be installed in Direct Vent (two pipe) applications.

In Direct Vent applications, combustion air is supplied from outdoors and flue gases are discharged outdoors.

Intake/Exhaust Piping

2 or 3 in. PVC pipe used for both intake and exhaust air. 2 in. connection from unit but may be transitioned to 3 in. PVC in a vertical run.

Vent pipe connector with integral condensate drain furnished as standard.

CPVC pipe MUST be used in the first five feet of the exhaust piping. Unit ships with 5 ft. of 2 in. CPVC pipe, one 2 in. CPVC coupling, elbow and short nipple.

See Intake/Exhaust Pipe Vent Lengths Table.

Condensate Trap

Integrated low profile condensate drain trap assembly is included on the unit.

Internal condensate drain tubing is furnished.

FEATURES

Optional Accessories

Termination Kit - Concentric

2 or 3 inch kit contains concentric termination assembly, reducer bushing and 45° elbow.

Kit requires single hole penetration of roof or wall for installation.

Roof penetration applications requires field supplied boot/flashing.

CSA certified.

CONTROLS

Integrated Boiler Control Module

Control module provides ignition sequence, flame monitoring and safety shutoff for hot surface ignition heating system.

Five diagnostic LEDs (POWER, PURGE, IGNITOR, VALVE, FLAME) aid in servicing.

Should flame fail to ignite, control will initiate 3 re-attempts at ignition before locking out unit operation for 60 minutes.

Watchguard type circuit automatically resets ignition controls after one hour of continuous thermostat demand after unit lockout, eliminating nuisance calls for service.

Thermal Purge Operation

Boiler control incorporates automatic means to insure usable residual heated water in the boiler is circulated until it is sufficiently depleted from the system before the burner is allowed to fire.

Casting Temperature Safety Switch

Protects the boiler in case of lack or loss of water.

Installed in the top of the boiler section, the switch will turn off the power to the Integrated Boiler Control when the temperature reaches setpoint, 300°F.

Manual reset. Verify that the boiler is properly filled before resetting.

Differential Pressure Air Proving Switch/Blocked Vent Safety Shutoff

Prevents unit operation in the event combustion air products passage through the flueway is reduced or blocked.

Automatic reset.

Hydrostat Combination High Limit Control / Low Water Cut Off With Boiler Temperature Reset

Limit control is factory set at 180°F, field adjustable from 100°F to 190°F (rotary DIP switch).

Automatic differential based on control settings and boiler temperature.

Integral manual reset low water cutoff.

LED indicators for the following conditions:

- HI TEMP - Indicates boiler water temperature has reached high limit setting. Remains lit until water temperature decreases 10°F below the high limit setting, preventing burner operation.

Low Water Cutoff

- ACTIVE - Indicates low water cut-off operation.
- LOW WATER - Indicates boiler low water condition.

Economy

- ACTIVE - Indicates thermal targeting function is operating and boiler control has reduced boiler temperature to conserve fuel. Economy feature is activated using the ECONOMY rotary DIP switch.
- TARGET - When active, boiler control continuously sets target temperature below high limit setting maximizing fuel efficiency. When boiler reaches target temperature, LED illuminates and burner shuts down. Boiler water continues to circulate for heating as long as thermostat demand continues. LED remains lit until boiler temperature drops below differential, allowing the boiler to fire again.

Purge/Testing

- PURGE - Boiler control is purging latent heat from boiler and will not fire until temperature drops to 135°F.
- TEST - Allows testing of low water operation.

ECONOMY rotary DIP switch allows setting of number of heating zones for maximum efficiency by reducing boiler temperature required, default setting is one zone.

Induced Draft Blower Temperature Safety Switch

Temperature safety switch prevents unit operation in case of high temperature of discharge flue gases.

Sensor is furnished as standard and factory installed on the induced draft blower outlet port.

Junction Box

Furnished on right side of cabinet for easy field wiring.

Transformer

50VA transformer furnished for control module operation.

Mounted on control panel.

Optional Accessories

Thermostat

See Thermostat bulletins in Controls section and Lennox Price Book for a complete list of thermostats.

CABINET

Constructed of heavy gauge steel with a baked-on enamel paint finish.

Gas connection and flue connections are furnished on the right side of cabinet.

Supply and return water connections are furnished on top of cabinet, alternate connection openings are located on the left side of the cabinet.

See dimension drawing.

Front access panel is easily removed for servicing.

SPECIFICATIONS

		Model No.	GWB9-050IH-3	GWB9-075IH-3	GWB9-100IH-3
Gas Heating Performance	Heating capacity input - Btuh		50,000	75,000	100,000
	Heating capacity output - Btuh		45,000	68,000	90,000
	¹ Net AHRI I=B=R rating - Btuh		39,000	59,000	78,000
	² AFUE		90%	90%	90%
Boiler Data	Number of boiler sections		2	2	2
	Boiler capacity		2.6 US gallons	2.6 US gallons	2.6 US gallons
Connections in.	³ Flue size connection diameter - round		2	2	2
	Gas piping size I.P.S.		1/2	1/2	1/2
	Water supply and return connection size		1-1/4 NPT	1-1/4 NPT	1-1/4 NPT
	Drain connection size		3/4 NPT	3/4 NPT	3/4 NPT
Electrical characteristics			120 volts - 60 hertz - 1 phase (less than 12 amps)		
Shipping Data	lbs. - 1 package		220	220	220

OPTIONAL ACCESSORIES

Concentric Vent Kit	US - 2 inch	69M29	69M29	69M29
	3 inch	60L46	60L46	60L46
	Canada - 2 inch	44W92	44W92	44W92
	3 inch	44W93	44W93	44W93
LPG/Propane Conversion Kit	0 - 10,000 ft	75E01	---	10T27
	0 - 5000 ft	---	70E01	---
	5001 - 10,000 ft	---	77E01	---

See Lennox Price Book For Complete Listing of Optional Accessories (Expansion Tanks, Valves, Circulator Pumps, etc.)

¹ AHRI I=B=R ratings indicate the amount of equivalent direct radiation each boiler will produce under normal conditions and thermostatic control. Ratings based on an allowance of 1.15 in accordance with the factors shown on the I=B=R Standard as published by The Hydronics Institute. Selection of boiler size should be based on "Net I=B=R Rating" being equal to or greater than the calculated heat loss of the building.

² Heating Capacity and AFUE (Annual Fuel Utilization Efficiency) based on US DOE test procedures and FTC labeling regulations.

³ CPVC pipe MUST be used in the first five feet. Unit ships with 5 ft. of 2 in. CPVC pipe, one 2 in CPVC coupling, one nipple and one elbow.

NOTE - Termination Kits **44W92**, **44W93** are certified to ULC S636 standard for use in Canada only.

INTAKE/EXHAUST PIPE VENT LENGTHS

Vent Pipe Diameter	GWB9-050-075		GWB9-100	
	Minimum	Maximum	Minimum	Maximum
2 in.	2 ft.	26 ft.	2 ft.	21 ft.
3 in.	20 ft.	112 ft.	15 ft.	92 ft.

NOTES:

One 90° elbow = 5 ft.

One 45° elbow = 3.5 ft.

One 2 x 3 in. adaptor = 0 ft.

Concentric Vent Kit (optional) = 5 ft.

INSTALLATION CLEARANCES

	in.	mm
Top	1	25
Top Service	8	203
Left Side	1	25
Right Side	11	279
Front	1	25
Front (Service)	24	610
Back	1	25
Base	Non-Combustible	
Intake/Exhaust Piping	0	0
Hot Water Piping	1	25

NOTE - Air for combustion must conform to the methods outlined in the National Fuel Gas Code (NFPA 54/ANSI-Z223.1) or the National Standard of Canada CAN/CSA-B149.1 "Natural Gas and Propane Installation Code".

NOTE - In the U.S. flue sizing must conform to the methods outlined in the current National Fuel Gas Code (NFPA 54/ANSI-Z223.1) or applicable provisions of local building codes. In Canada flue sizing must conform to the methods outlined in National Standard of Canada CAN/CSA-B149.1.

HIGH ALTITUDE DERATE

US

- CSA certified units for the U.S. are factory equipped for operation from 0 to 10,000 feet above sea level. No changes to the factory settings are required for installations from 0 to 5000 feet above sea level.
- At altitudes from 5001 to 10,000 feet above sea level the gas manifold pressure must be adjusted based on the value of the supply gas to achieve a Combustion Setting CO₂ range as shown in the Table below. See Installation Instructions for additional information about measuring and adjusting the manifold pressure.

CANADA

- CSA certified units for Canada are factory equipped for operation from 0 to 4500 feet above sea level without any changes to the factory settings.
- At altitudes over 4500 feet above sea level units must be derated according to local utility codes.

Model No.	Factory Setting	Gas Value - NATURAL GAS (Btu)				
		750	850	950	1000	1050
	0-5000 ft.	5000-10,000 ft.				
GWB9-050IH-3 GWB9-075IH-3 GWB9-100IH-3		Combustion Setting (CO ₂) - 8.7 - 9.7% (CO < 100 ppm)				
Model No.	Factory Setting	Gas Value - LPG/PROPANE (Btu)				
		2300	2350	2400	2450	2500
	0-5000 ft.	5000-10,000 ft.				
GWB9-050IH-3 ¹ GWB9-075IH-3 GWB9-100IH-3		Combustion Setting (CO ₂) - 10.0 - 11.1% (CO < 100 ppm)				

¹ GWB9-075IH-3 LPG/Propane applications for 5001-10,000 feet above sea level require an orifice change as well as gas manifold pressure adjustment. See installation instructions for details.

DIMENSIONS - INCHES (MM)

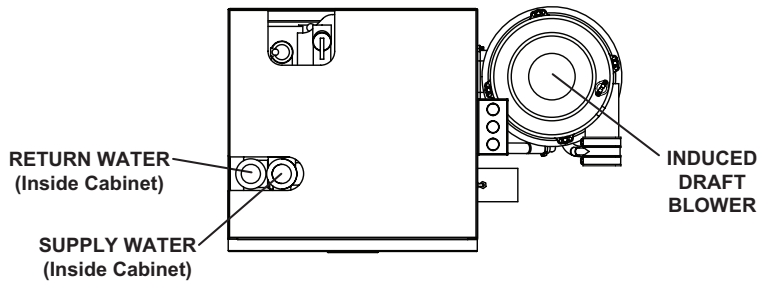

TOP VIEW

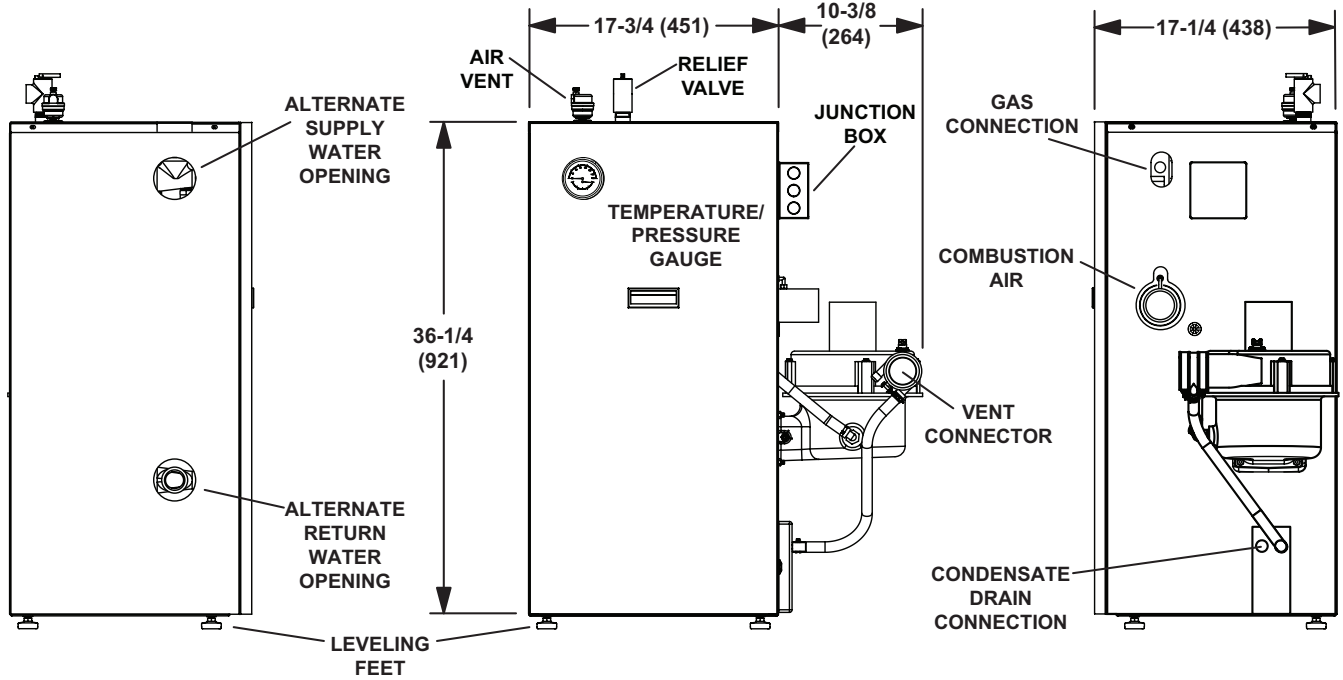

OPTIONAL ACCESSORY DIMENSIONS - INCHES (MM)

69M29 / 44W92 – 2 inch kits
 60L46 / 44W93 – 3 inch kits
 See Installation Instructions for additional information.

Note - Field provided reducer may be required to adapt larger vent pipe size to termination.

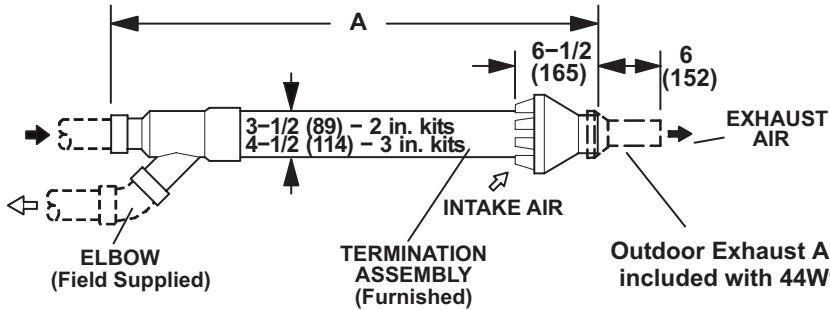

Cat. No.	A		B	
	in.	mm	in.	mm
69M29	33-3/8	848	16-3/4	425
44W92 (Canada)	29	737	15-1/2	394
60L46	38-7/8	987	21-3/16	538
44W93 (Canada)	36-1/8	918	19-1/2	495

NOTE - Typical illustration for dimensions only. Design may vary depending on kit ordered.

CONCENTRIC WALL TERMINATION APPLICATIONS

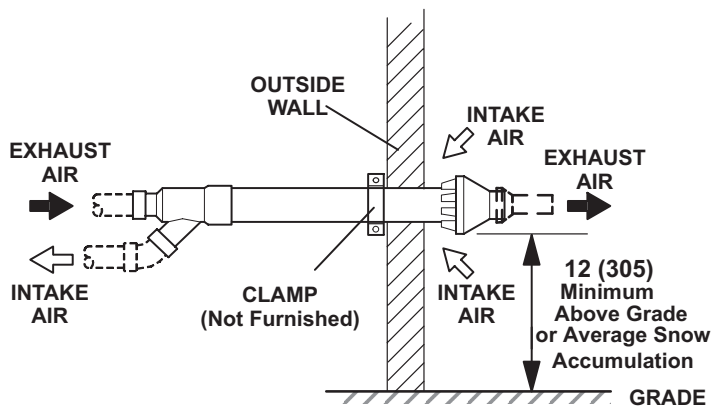

CONCENTRIC ROOF TERMINATION APPLICATIONS

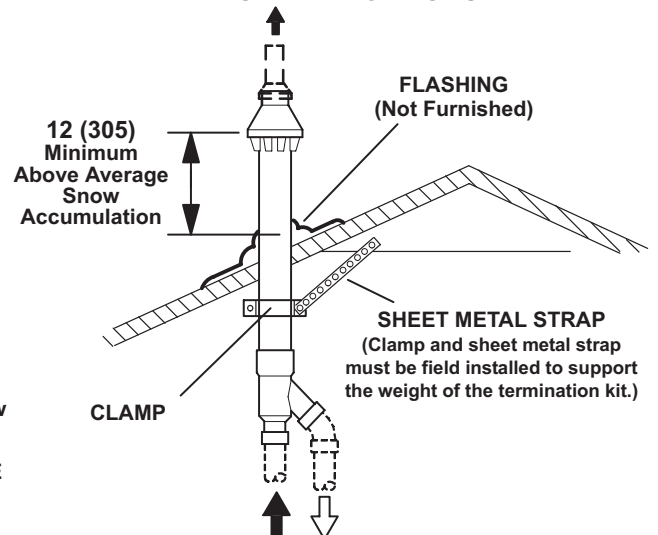

CIRCULATING PUMP FLOW RATE



FLOW-M³/H

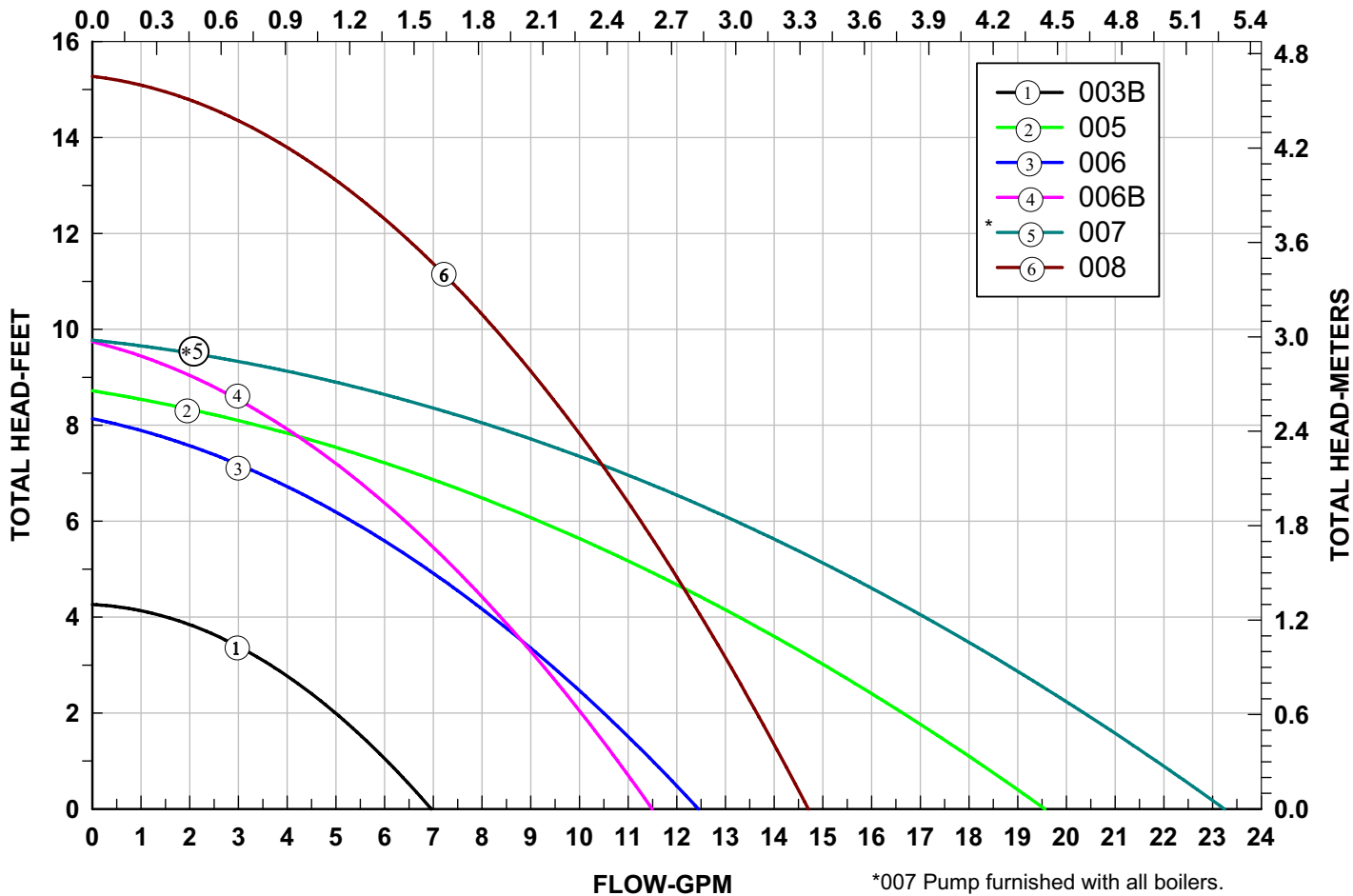

REVISIONS

Sections	Description of Change
New	Added circulator pump flow rate chart.

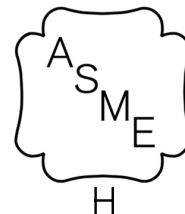

Visit us at www.lennox.com

For the latest technical information, www.LennoxPros.com

Contact us at 1-800-4-LENNOX

NOTE - Due to Lennox' ongoing commitment to quality, Specifications, Ratings and Dimensions subject to change without notice and without incurring liability. Improper installation, adjustment, alteration, service or maintenance can cause property damage or personal injury. Installation and service must be performed by a qualified installer and servicing agency.