



HARMONY III™

Zoning System for Residential, Variable Air Volume Heating/Cooling Systems

Bulletin No. 210405
July 2019
Supersedes August 2015

RESIDENTIAL PRODUCT SPECIFICATIONS



FEATURES

WARRANTY

- Zone Control Panel - Limited two year in residential applications

NOTE - Refer to Lennox Equipment Limited Warranty certificate included with unit for specific details.

ZONE CONTROL SYSTEM

- Harmony III™ Zoning System is capable of controlling up to four separate zones
- Panel is capable of controlling multi-stage equipment, 2 heat / 2 cool conventional heating/cooling systems and 3 heat / 2 cool heat pump and dual fuel systems
- System consists of the Control Panel, discharge air sensor (furnished), field-supplied duct-mounted motorized zone dampers with a thermostat in each zone
- Panel is powered by a separate stand-alone transformer
- Zone dampers are automatically controlled to supply air flow only to zones with a thermostat demand
- Individual air volumes for heating or cooling are available to each zone
- Round or rectangular dampers can be used
- Zoning system allows temperature setback in unoccupied areas while maintaining comfort in occupied areas
- Auto-changeover control from any zone thermostat or control heating/cooling mode to all zones from the zone 1 thermostat
- Compatible with standard heat/cool electronic thermostats (non-power robbing). See recommended thermostats

- Also compatible with Humiditrol® Whole Home Dehumidification System (with optional Interface Board).

ZONE CONTROL PANEL

- Microprocessor controlled panel contains all necessary relays and controls to operate the system
- Automatic reset in case of operation error or power failure
- Built-in time delay function (5 minutes) prevents short cycling of system
- 3A (slow-blow) fuse protects panel from shorts in the thermostat and damper field wiring. Spare 3A fuse included
- Cabinet and removable cover constructed of high impact plastic
- Holes for mounting are furnished and electrical inlets are provided in cabinet
- Dimensions (H x W x D): 12 x 9-1/2 x 2-1/4 in.
- Shipping weight: 2 lbs.
- Power requirements: 24VAC (18-30VAC)
- Low Voltage Equipment Terminals
 - Four zones (dampers) (NC, NO, C)
 - Heating/Cooling equipment connections (RC, RH, Y1, Y2, O, G, W1, W2, W3, DS, W1 - Def)

FEATURES

ZONE CONTROL PANEL (continued)

Low Voltage Control Terminals

- Four zone thermostats (W, C, Y, G, R)
- Discharge air sensor
- Balance point sensor
- Pressure switch (heat pump systems only)
- Setup Jumpers
- HEATING STAGE TEMP (85, 90, 100, 110, 120, 130)
- COOLING STAGE TEMP (50, 55, 60)
- CONT. AIR REDUCTION (0%, 25%, 50%, 75%)
- HEATING AIR REDUCTION (0%, 20%, 40%)
- ZONE 1, 2, 3, 4 PIAB (0 to 100%)
- SYSTEM CONFIGURATION (HP, GAS, 2COOL, 1COOL, 2HP, 1HP)
- E-HEAT STAGES (DF, 1, 2, 3)

Display LED's

- Damper 1, 2, 3, 4 (LED's lit when zone dampers are closed)
- E-Heat Mode (LED lit in emergency heat mode)
- Central Mode (LED lit in vacation mode)
- Fan On (LED lit when fan is operating)
- Cooling (LED lit when cooling equipment is operating)
- Heating (LED lit when heating equipment is operating)
- Electric Heating (LED lit when electric heat is operating)
- Status (power, flashing)

Additional Control Board LED's

- Y1, Y2, O, W1 Def., W1, W2, W3 (LED's lit showing heating/cooling equipment operation)
- Thermostat LEDs: one set for each zone, green - cooling call, red - heating call, and amber - blower call

Timer Delay Override Button (TDO)

- Speeds up onboard timer by a factor of 60 for system checkout

ZONE CONTROL PANEL JUMPER SETTINGS

- See Installation Instructions for detailed information on configuration

Heating Staging Temperature Jumper

- Used to set the discharge air temperature that will be maintained by staging the equipment
- Selectable between 85°F and 140°F with a built-in differential of 20°F
- Recommended settings: 90°F for heat pumps, and 110°F for gas furnaces
- In heat pump applications, the electric heat will be staged to maintain the discharge air temperature set by the heating stage jumper position

Cooling Staging Temperature Jumper

- Used to set the discharge air temperature that will be maintained by staging the equipment
- Selectable between 50°, 55°, and 60°F. with a built-in differential of 7°F

Continuous Air Reduction

- During continuous fan mode with no heating or cooling demand, the blower runs at the CFM calculated from the jumper settings of the zones calling for continuous fan and is reduced by the percentage selected on this bank of jumpers
- Selections are 0%, 25%, 50% and 75%

Heating Air Reduction

- The heating air reduction jumper enables the blower speed, during heating, to be reduced by a percentage of the cooling blower speed
- Selections are 0%, 20% and 40%
- Heat pump applications, always set the jumper on 0%. High head pressures may result if air is reduced during heating mode

Zone PIAB (Percent Into Adjustment Band)

- The adjustment band is the difference between the minimum and maximum CFM rating of the air handler
- Setting allows an appropriate percentage of air volume to each zone
- Volume settings must be selected for zone 1 and at least one other zone
- Selections are: 0 to 100% in increments of 10%
- See Installation Instructions for more information

System Configuration

- Selects the type of cooling and heating system that has been installed
- Select the number of equipment stages by placing the jumper to the appropriate side (HP or GAS, 1COOL or 2COOL, and 1HP or 2HP)

E-Heat Stages

- Selects number of electric heat stages that are available
- Jumper must be set to DF for dual fuel operation
- Selections are DF, 1, 2, and 3

FEATURES

SLIDE SWITCHES

Central Mode (Vacation) (On/Off)

- Allows Zone 1 to control entire system during unoccupied times
- All zone dampers remain open. Central Mode LED is lit when operating

Emergency Heat (On/Off)

- Used with heat pump systems only
- Allows any call for heat to use auxiliary heat
- Allows homeowner to activate emergency heat when heat/cool thermostats are installed in all zones
- E-Heat LED is lit when operating

DISCHARGE AIR SENSOR (furnished)

- Field installed in supply air plenum
- Senses discharge air temperature to control system
- Relays information back to the zone control board so the board can control first and second stage heating and cooling based on discharge air temperature
- Temperature settings are controlled by jumpers on the zone control board

SYSTEM EQUIPMENT DATA

- For furnace data, see Gas Furnaces
- For air handler unit data, see Air Handlers
- For air conditioning units data, see Air Conditioners
- For heat pump data, see Heat Pump Outdoor Units
- For add-on indoor coil unit data, see Indoor Coils

ZONES VS. OUTDOOR UNIT TYPES

No. of Zones	Comparative Zone Sizes	Lennox Air Conditioner or Heat Pump
2	Equal	Single or Two-Stage
2	Unequal	Two-Stage Only
3 or 4	Equal or Unequal	Two-Stage Only

SEQUENCE OF OPERATION

When power is first applied, the green Status LED will flash, indicating that the board is functioning normally. When the board is first powered on, there is a 5 minute minimum off time delay during which only the fan output will respond.

In the heating mode, heating operation will continue until all heat demands have been satisfied. Any existing cooling demands will then be satisfied. Heating operation is only interrupted if an Emergency Heat demand (heat pump applications only) exists or if a cooling demand from another zone exists for 20 minutes. Cooling operation will continue until all cooling demands have been satisfied or if a heating demand from another zone exists for 20 minutes.

Heat/Cool Changeover:

When a demand for heating or cooling exists and an opposing demand is made from another zone, a 20-minute timer is activated. If the original demand is not satisfied within the 20-minute time period, the demand will be interrupted, turning the equipment off and allowing for the normal equipment off time delay. The opposing demand will then be initiated. After 20 minutes, if the original demand still exists, the opposing demand will be terminated and the original demand can once again be reinstated.

DAMPER OPERATION

The "NO" output will be energized and the "NC" output will be de-energized for any zone not calling for heating or cooling during heating/cooling equipment operation and during the damper purge time delay. During heating/cooling equipment operation or during the damper purge time delay, should all zones stop calling for heating or cooling, the dampers will remain in the position they were in before all zones stopped calling.

CONTINUOUS FAN OPERATION

Continuous fan operation is available from any zone thermostat. Zone dampers not calling for continuous fan operation will close.

HEATING/COOLING OPERATION

Cooling Operation - Conventional Heat/Cool and Heat Pump Systems

When a zone thermostat makes a demand for cooling, the zone damper opens and the cooling equipment begins operating.

Cooling demand is terminated when:

1. All zone demands for cooling are terminated.
2. The demand has exceeded the heat/cool changeover time limit (20-minutes) while a heat demand exists.

When cooling demand is terminated, a 5 minute minimum off time delay is initiated.

Second stage cooling is energized when the discharge air temperature is 7°F higher than the set point of the cooling staging temperature jumper.

Heating Operation - Conventional Heat/Cool and Heat Pump Systems

When a zone thermostat makes a demand for heating, the zone damper opens and heating equipment begins operating. Heating demand is terminated when:

1. All zone demands for heating are terminated.
2. The demand has exceeded the heat/cool changeover time limit (20-minutes) while a cooling demand exists.

When heating demand is terminated, a 5-minute minimum off time delay is initiated

Second stage heating is energized if the discharge air temperature is lower than the set point of the heating staging temperature jumper

Dual Fuel Operation

The Control Panel will control a dual fuel system when the HP / GAS jumper is set to HP and the E-HEAT Stages jumper is set to DF. The dual fuel system is set up so that the first and second stage compressor operation turns off before the auxiliary heat is turned on. Dual fuel mode effects auxiliary heat operation only.

To lock out the heat pump at low ambient conditions (below the system balance point) and use the gas furnace for heating demands a balance point sensor needs to be installed. When the outdoor temperature is above the balance point, the HP will be used to satisfy the heating demand. If the discharge air temperature falls below the heating staging jumper setting for 20 minutes during heat pump heating, the heat pump will be turned off and the furnace will be used to satisfy the heating demands for the next 3 hours. During this time, diagnostic lights 2, 3, and 4 will flash. At the end of 3 hours, the heat pump will be tried again. Below the balance point, all heat demands are serviced by the gas furnace.

Emergency Heat Operation - Heat Pump Systems

When the control center is used with a heat pump and the Emergency Heat switch is turned ON, the unit will satisfy all heating demand with electric backup heat. When the Emergency Heat Switch is OFF, the heat pump is used to satisfy heating demands. (This switch has no effect on operation in a non-heat pump system.)

Whole Home Dehumidification Operation - Humiditrol®

Harmony III Zoning System can be used with the Humiditrol Whole Home Dehumidification System

A separate Humiditrol® Zoning Accessory must be used for proper operation. See for detailed information

NOTE - Operation with the Humiditrol Whole Home Dehumidification System is only possible with the latest Harmony III Control Panel (**X9953**). Humiditrol will not work with earlier versions!

NOTE - Humiditrol Zoning Accessory (**39W67**) is also required.

OPTIONAL ACCESSORIES

CONTROLS

Transformer

- 24VAC transformer is required for operation of Zone Control Panel, thermostats and zone dampers
- Transformer size is determined by the total power requirements of the control panel, thermostats and damper
- See page 6 for ordering information
- Zone Control Panel and Thermostats require 10VA
- Dampers require 10VA each

Balance Point Sensor

- Used to lock out the heat pump at low ambient conditions (below the system balance point)

Defrost Tempering Kit

- For dual-fuel heat pump applications. Used to temper the indoor air during the defrost cycle

Pressure Switches

- A pressure switch is required for applications with a Lennox heat pump
- Guards against high head pressures during first- and second-stage heating

DAMPERS

Zone Dampers

- Any style 24VAC damper is compatible with the Harmony III™ Zoning System
- Spring-open/power-close dampers are the preferred, however, power-open/spring-close and power-open/power-close dampers can be used
- At least one damper per zone is required
- Up to 5 dampers per zone may be connected in parallel to the Harmony Panel, not to exceed a total of six dampers for entire system

NOTE - If additional dampers are required, refer to the special wiring diagram in the Installation Instructions for additional information.

- See page 6 for ordering information

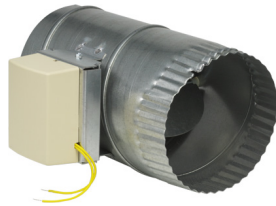

ZONE THERMOSTATS

- A single-stage, non-heat pump, non-power-robbing electronic thermostat is required for each zone
- Each thermostat must have a dead band between HEAT and COOL
- In central control mode, the zone 1 thermostat is designated as the master thermostat and it controls the entire house
- The other thermostats are not used

NOTE - Lennox recommends that the zone 1 (master) thermostat be programmable

- Individual zone thermostats can also be programmable
- For all zones, use single-stage, electronic, non-heat pump thermostats
- Recommended thermostats include ComfortSense® 7500, 5500 and 3000 Series Thermostats
- See Lennox Price Book for additional compatible thermostats

ComfortSense® 7500 Touchscreen Fully Programmable Thermostat

- 4 Heat/2 Cool
- 7 Day programmable
- Auto-changeover
- Easy-to-use, touch screen thermostat
- See the Product Specifications bulletin for individual thermostats for more information

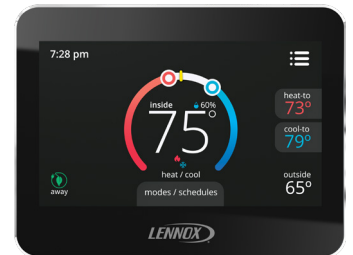

ComfortSense® 5500 Touchscreen Fully Programmable Thermostat

- 1 Heat/1 Cool
- 7 Day programmable
- Easy-to-use, touch screen thermostat
- See the Product Specifications bulletins in the Controls section for more information



ComfortSense® 3000 5-2 Day Programmable and Non-Programmable Thermostats

- 1 Heat/1 Cool
- Easy-to-use
- 5-2 Day programmable or non-programmable models available
- See the Product Specifications bulletins in the Controls section for more information

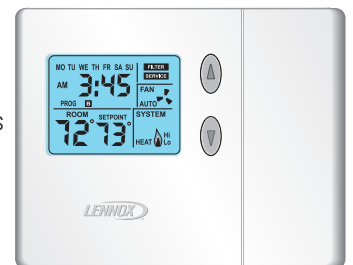

OPTIONAL ACCESSORIES

		Description	Catalog No.			
Pressure Switches		for R-410A systems	27W13			
Balance Point Sensor			10Z23			
Defrost Tempering Kit			67M41			
Transformers		120/208/240V primary / 24V secondary - 40VA (3 dampers)	10P17			
		120/208/240V primary / 24V secondary - 50VA (4 dampers)	10P87			
		120/208/240V primary / 24V secondary - 75VA (6 dampers)	12P61			
		4 in. square Electrical Box	83P74			
Thermostats - See Controls section and Lennox Price Book for additional thermostats.						
		ComfortSense® 7500 Touchscreen Thermostat - 4 heat/2 cool - Fully programmable	13H14			
		ComfortSense® 5500 Touchscreen Thermostat - 1 heat/1 cool - Fully programmable	13H13			
		ComfortSense® 3000 Programmable Thermostat - 1 heat/1 cool - 5-2-day programmable	51M34			
		ComfortSense® 3000 Thermostat - 1 heat/1 cool - Non-programmable	51M32			
Humiditrol® Zoning Accessory			39W67			
Freezestats - For use with Humiditrol system		3/8 in.	93G35			
		1/2 in.	39H29			
		5/8 in.	50A93			
Dampers Zone Control Power Close / Spring Open	Round	6 in. Round	X4207	11 in. Round	X4212	
		7 in. Round	X4208	12 in. Round	X4213	
		8 in. Round	X4209	14 in. Round	X4214	
		9 in. Round	X4210	16 in. Round	X4215	
		10 in. Round	X4211			
	Bottom Mount - Two Wire	8 in. x 10 in.	X4252	10 in. x 18 in.	X4263	
		8 in. x 12 in.	X4253	10 in. x 20 in.	X4264	
		8 in. x 14 in.	X4254	10 in. x 22 in.	X4265	
		8 in. x 16 in.	X4255	10 in. x 24 in.	X4266	
		8 in. x 18 in.	X4256	12 in. x 14 in.	X4267	
		8 in. x 20 in.	X4257	12 in. x 16 in.	X4268	
		8 in. x 22 in.	X4258	12 in. x 18 in.	X4269	
		8 in. x 24 in.	X4259	12 in. x 20 in.	X4270	
		10 in. x 12 in.	X4260	12 in. x 22 in.	X4271	
		10 in. x 14 in.	X4261	12 in. x 24 in.	X4272	
		10 in. x 16 in.	X4262			
		Side Mount - Two Wire	8 in. x 8 in.	X4216	22 in. x 10 in.	X4234
			10 in. x 8 in.	X4217	24 in. x 10 in.	X4235
			12 in. x 8 in.	X4218	26 in. x 10 in.	X4236
	14 in. x 8 in.		X4219	28 in. x 10 in.	X4237	
	16 in. x 8 in.		X4220	30 in. x 10 in.	X4238	
	18 in. x 8 in.		X4221	12 in. x 12 in.	X4239	
	20 in. x 8 in.		X4222	14 in. x 12 in.	X4240	
	22 in. x 8 in.		X4223	16 in. x 12 in.	X4241	
	24 in. x 8 in.		X4224	18 in. x 12 in.	X4242	
	26 in. x 8 in.		X4225	20 in. x 12 in.	X4243	
28 in. x 8 in.	X4226		22 in. x 12 in.	X4244		
30 in. x 8 in.	X4227		24 in. x 12 in.	X4245		
10 in. x 10 in.	X4228		14 in. x 14 in.	X4246		
12 in. x 10 in.	X4229	16 in. x 14 in.	X4247			
14 in. x 10 in.	X4230	18 in. x 14 in.	X4248			
16 in. x 10 in.	X4231	20 in. x 14 in.	X4249			
18 in. x 10 in.	X4232	22 in. x 14 in.	X4250			
20 in. x 10 in.	X4233	24 in. x 14 in.	X4251			

COMPONENT SELECTION

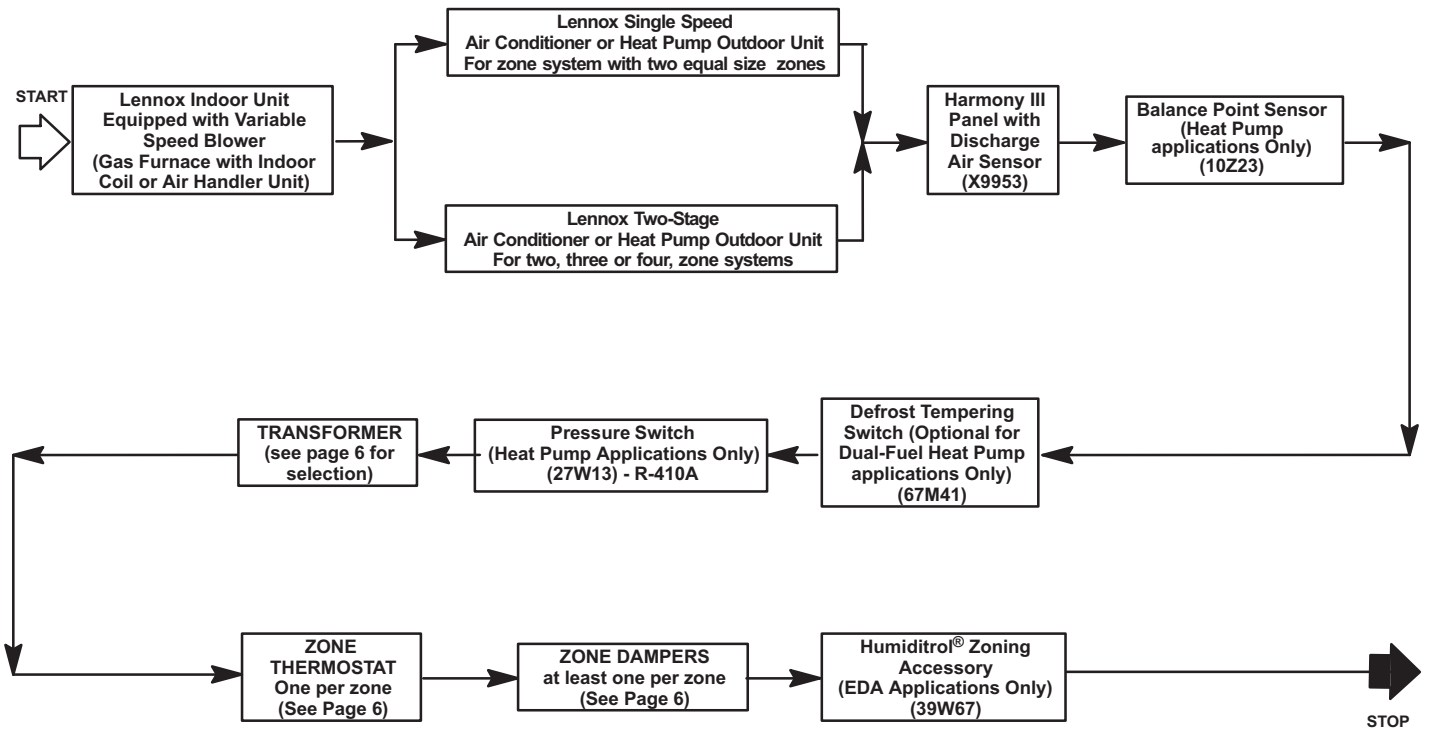

TYPICAL SYSTEM LAYOUT

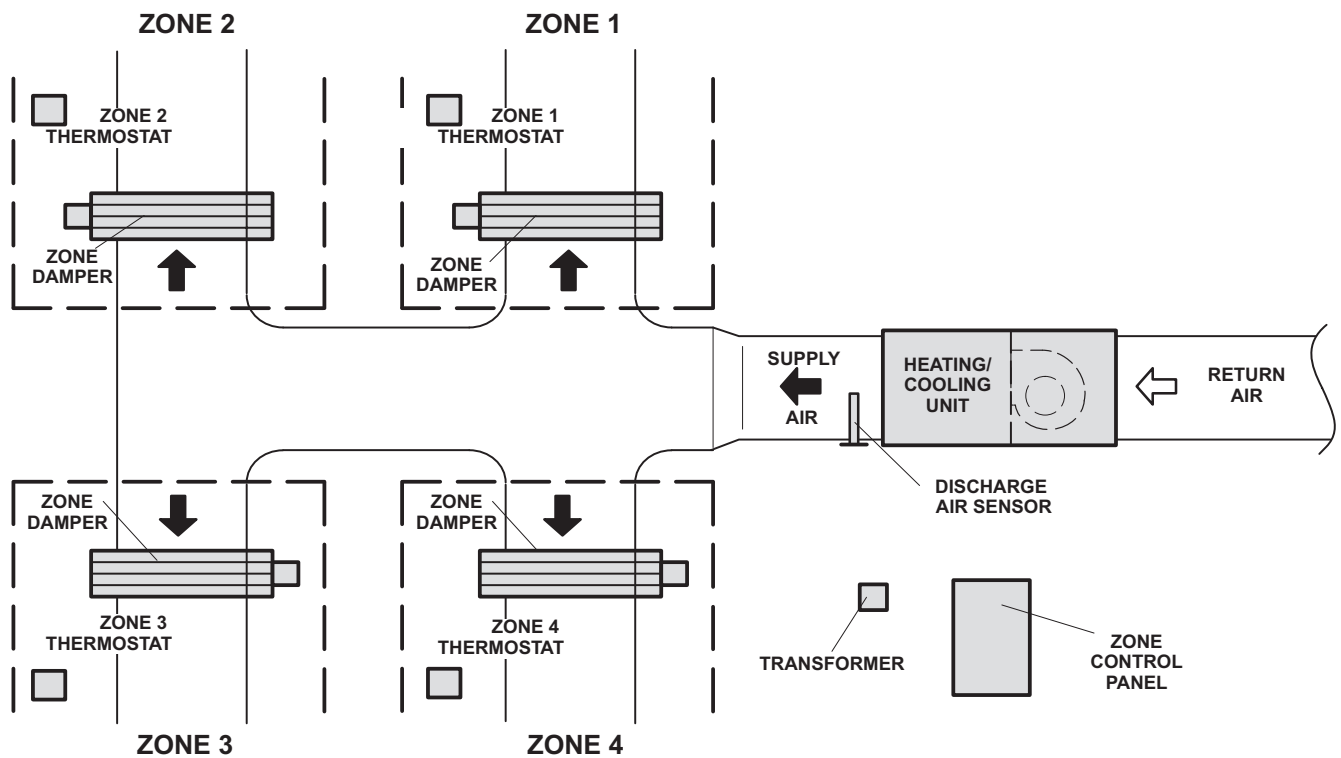

FIELD WIRING

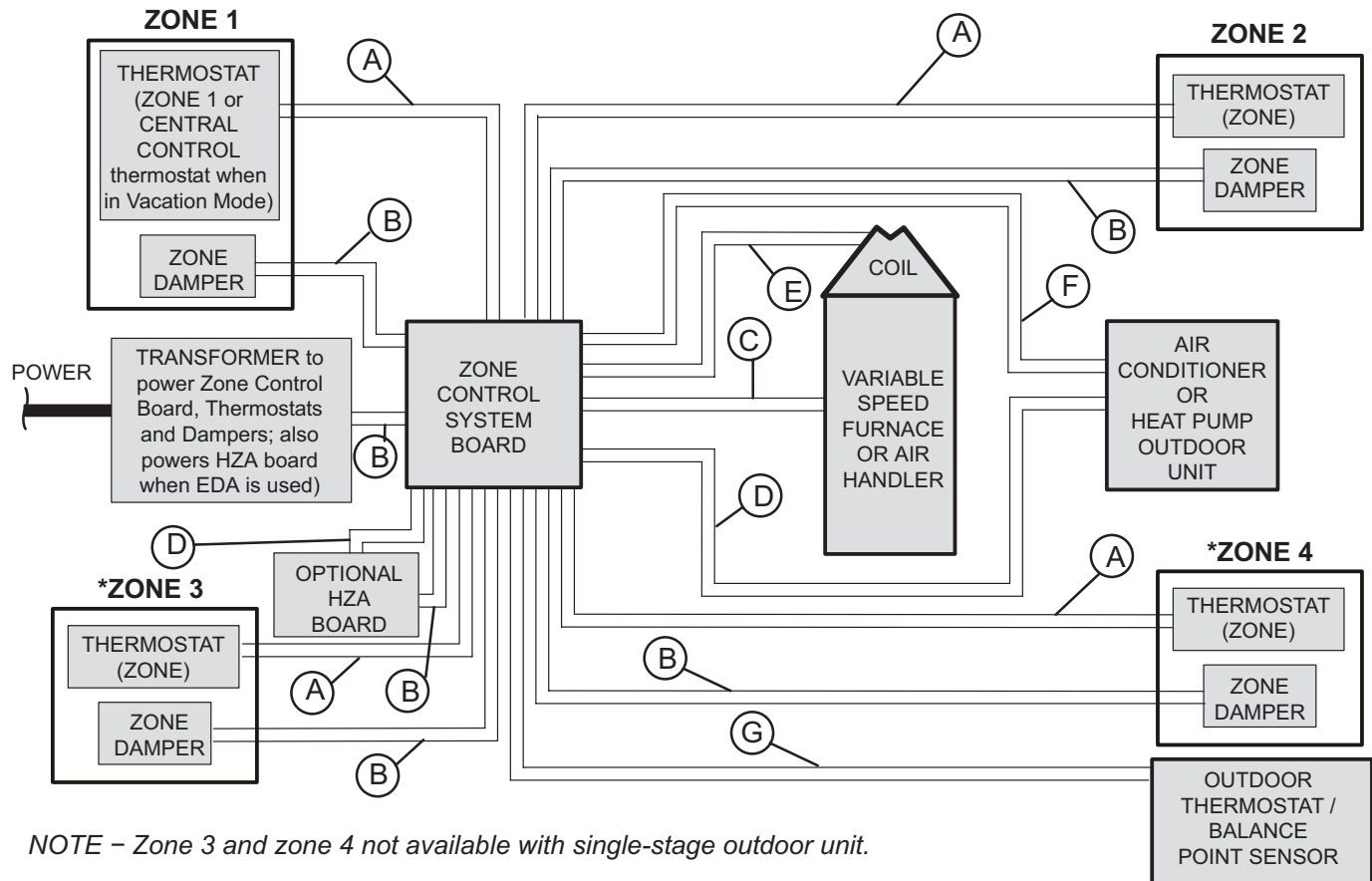

- A** – Five wire low voltage – 18 ga. minimum
- B** – Two wire low voltage – 18 ga. minimum
- C** – Up to nine wire low voltage – 18 ga. minimum
- D** – Two wire low voltage (single-stage air conditioner or EDA) 18 ga. minimum
- Three wire low voltage (two-stage air conditioner) 18 ga. minimum
- Up to seven wire low voltage (single-stage heat pump outdoor unit) 18 ga. minimum
- Up to eight wire low voltage (two-stage heat pump outdoor unit) 18 ga. minimum

- E-** – Two wire low voltage (discharge air sensor) – 18 ga. minimum
- F-** – Two wire low voltage – pressure switch (heat pump only) – 18 ga. minimum
- G** – Two wire – 18 ga. minimum

HUMIDITROL ZONING ACCESSORY

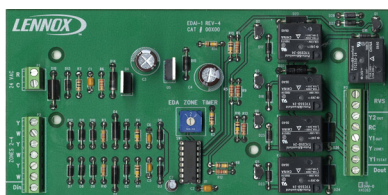

The Humiditrol Zoning Accessory is required for proper operation of the Harmony III™ Zoning System when used with the Humiditrol®

Whole Home Dehumidification System (EDA). Refer to Installation Instructions for detailed information about system operation.

System Selector Switch

- Three position switch on control allows three different operating modes
- **Position 1** - (EDA) Dehumidification demand has priority over heating/cooling demands from zones 2 - 4.
- **Position 2** - (ZONE) Heating/cooling demands for all zones have priority over a dehumidification demand. Factory setting.
- **Position 3** - (TIMER) Internal timer (non-adjustable) will cycle system between dehumidification demand and heating/cooling demand every twenty minutes. Cycling only occurs when there is a demand for both.

Thermostat

- The zone 1 master room thermostat must be a "reverse logic" type (outputs a 24 volt AC signal when there is NO dehumidification demand and a 0 volt signal when there IS a dehumidification demand).
- The ComfortSense® 7500 Thermostat meets these requirements. See Optional Accessories Table for selection.

Transformer

- Five (5) volt-amps (VA) are required for the EDA interface control which must be powered by the same system transformer that powers the Zone Control Board, thermostats, and zone dampers. See Optional Accessories Table for selection.

Freezestats (Indoor Coil)

- If the minimum air requirement for the EDA system is less than 350 cfm per ton, it is recommended that a freezestat be installed on the indoor coil to prevent icing of the coil. The freeze-stat senses when suction line temperature falls below its setpoint and cycles the compressor off. The freeze-stat opens at 29°F and closes at 58°F. See Optional Accessories Table for selection.

Discharge Air Sensor

- Discharge Air Sensor furnished with Harmony III Zone Control Board must be installed on the outlet side of the EDA system.

Outdoor Air Temperature Sensor

- For proper operation of Harmony III Zone Control with EDA applications, an outdoor air temperature sensor **MUST** be installed.

Cabinet

- The Humiditrol Zoning Accessory comes in a high impact plastic case that matches the Harmony III control panel.

CONTROL BOARD LAYOUT

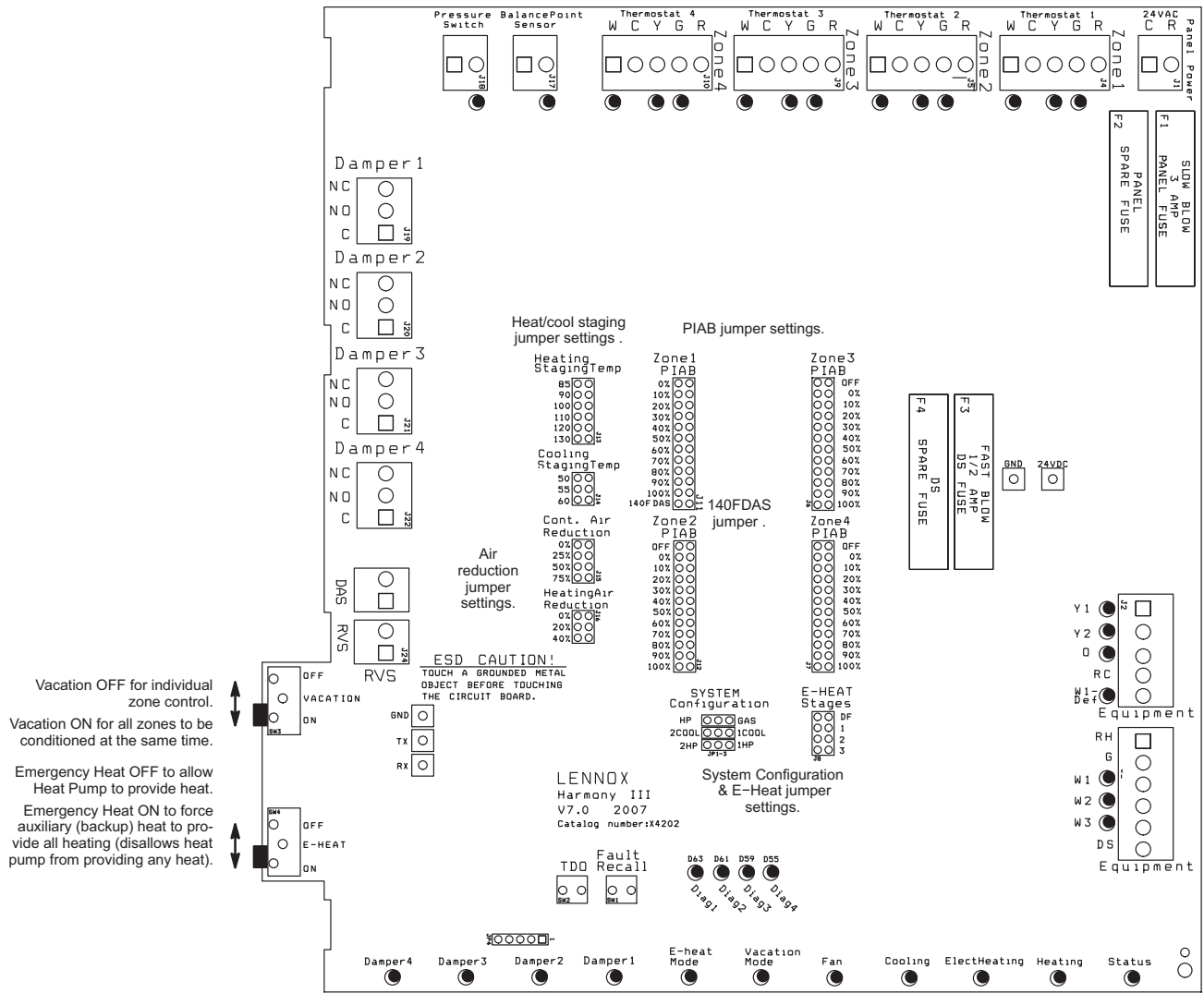

NOTE – See Installation Instructions for different system wiring configurations.

REVISIONS

Sections	Description of Change
Optional Accessories	Updated catalog number for Balance Point Sensor.



Visit us at www.lennox.com

For the latest technical information, www.LennoxPros.com

Contact us at 1-800-4-LENNOX

NOTE - Due to Lennox' ongoing commitment to quality, Specifications, Ratings and Dimensions subject to change without notice and without incurring liability. Improper installation, adjustment, alteration, service or maintenance can cause property damage or personal injury. Installation and service must be performed by a qualified installer and servicing agency.

©2019 Lennox Industries, Inc.