



HCWHD

Healthy Climate® Whole-Home Dehumidifier

Bulletin No. 210699
September 2020
Supersedes February 2020

RESIDENTIAL PRODUCT SPECIFICATIONS



NOTE - ENERGY STAR® Rating for HCWHD3-130 Model Only.

Nominal Capacity - 70 to 130 pints per day

MODEL NUMBER IDENTIFICATION

HCWHD - 3 - 095

Unit Type
HCWHD = Healthy Climate® Whole Home Dehumidifier

Major Design Sequence = 3

Nominal Capacity
070 = 70 pints per day
095 = 95 pints per day
130 = 130 pints per day

CONTENTS

Approvals and Warranty	2
Dimensions	13
Electrical Data	6
Features	2
Installation Clearances	13
Optional Accessories	7
Performance	8
Sizing Guidelines	12
Specifications	6
Typical Applications	14

APPROVALS AND WARRANTY

APPROVALS

- CSA Listed
- ENERGY STAR® certified unit (HCWHD3-130 model only) is designed to use less energy, help save money on utility bills, and help protect the environment

WARRANTY

- All Covered Components
 - Limited five year warranty in residential applications
 - Limited one year in non-residential applications

NOTE - Refer to Lennox Equipment Limited Warranty certificate included with unit for specific details.

FEATURES

APPLICATIONS

- Healthy Climate Whole Home Dehumidifier is designed to control humidity throughout the home or in specific locations such as an attic, crawlspace or basement
- Also used for zoned dehumidification and ventilation control
- Humidity sensor automatically and continually measures the relative humidity
- Based on sensor measurement, the unit will operate to control the humidity based on the set point
- Zoning option dehumidifies a "Primary" zone space (example: living space) or a "Secondary" zone space (example: basement) to control humidity levels in different areas as needed
- Patented, built-in ventilation feature allows fresh air to be brought into the home from the outside
- Dehumidifier will condition the incoming air if needed

FILTER

- Washable, MERV 8 (Minimum Efficiency Reporting Value) filter furnished

BLOWER ASSEMBLY

- UL approved impeller type with backward curved centrifugal fan equipped with maintenance free ball bearings

EVAPORATOR COIL

- Aluminum coil for superior corrosion resistance

COMPRESSOR

- R-410A, rotary-type compressor

CABINET

- Constructed of 22 gauge, post-painted steel
- Interior is lined with 1/2 in., foil-faced, expanded polystyrene to eliminate noise, condensation and air loss
- The supply outlet is equipped with a built-in backflow damper
- Duct start collars (10 inch diameter) are included
- Supply collar can be relocated from the end of the cabinet to the top if space is restricted
- Adjustable feet (up to 2 in.) to level unit

NOTE - If the dehumidifier is installed in an attic or location requiring leak protection, the unit should be placed in a secondary condensate drain pan with a normally closed condensate overflow safety switch (float switch)

DIGITAL ONBOARD CONTROL

- Factory installed on the top of the unit

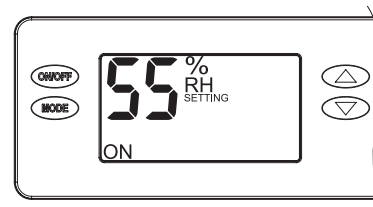

- Depending on dehumidifier location the control can be moved to the duct inlet end of the unit for easier accessibility
- Simple, backlit, menu-driven control allows complete operation of dehumidification and ventilation features
- Control will display the humidity setting when unit is not running, and display the measured humidity when running
- UP and DOWN arrow buttons allow the humidity level to be set from 40% to 80% relative humidity
- ON/OFF button turns the dehumidifier on or off
- MODE button allows access to optional ventilation (timed and auto) and zoning features and installer setup menu (hold for 3 seconds)
- Filter Reminder displays CLEAN FILTER every six months (press Up/Down Arrow buttons simultaneously for 3 seconds to clear)

External Control Operation

- The control can be set to operate using an external wired control
- See Optional Accessories section for available controls

Dehumidification Operation Options

- Unit can be set to operate during HVAC air-conditioning operation or only when HVAC air conditioning is off

FEATURES

VENTILATION

- The dehumidifier can activate a normally closed damper to bring in outdoor air through a fresh air intake duct
- Settings are available at the Digital Onboard Control

Timed Ventilation Features (Vent Timed Mode)

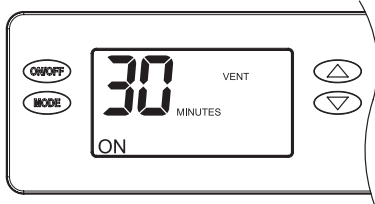

Press the UP or DOWN arrows to adjust the ventilation time per hour from 0 to 60 minutes.

Automatic Ventilation Features (Auto Mode)

- Three different settings based on outdoor temperature are available:
 1. **Vent-Auto-B** - Ventilation is disabled when outdoor temperature is below 0°F and above 100°F. Between 0°F and 20°F ventilation is only allowed during an HVAC heating demand
 2. **Vent-Auto-C** - Ventilation is disabled when outdoor temperature is below 0°F and above 100°F
 3. **Vent-Auto-D** - Ventilation is disabled when outdoor temperature is below 0°F and above 100°F. Between 0°F – 40°F ventilation is only allowed during an HVAC heating demand

NOTE - Outdoor temperature sensor is required for ventilation options above. Sensor must be ordered extra.

ZONING

Zone Mode

- Zone control can be enabled and disabled from the Digital Onboard Control
- When zone control is enabled two zones are available
 1. **Primary Zone** - Zone dampers are energized
 2. **Secondary Zone** - Zone dampers are de-energized

VENTILATION

- The built-in ventilation feature is designed to be meet ASHRAE 62.2 Standard for Ventilation
- Utilizes the dehumidifier and furnace/air handler blower to make-up any remaining ventilation required based on chosen set point
- In hot, humid climates, supplemental dehumidification of fresh air is recommended
- Automatically monitors and controls the humidity of the incoming air
- The dehumidifier can also operate an optional ventilation damper to bring air in from outside
- To keep it from using outdoor air above 100°F or below 0°F, an optional Outdoor Temperature Sensor must be field installed

AIR CYCLING

- An integrated air cycling feature can activate the furnace/air handler blower to cycle air through the house to balance the indoor air conditions
- Monitors furnace/air handler blower run-time to efficiently ventilate the whole home
- Air cycling will cycle furnace/air handler blower to the values set on the control

REQUIRED COMPONENTS

Drain Pan

- Required if unit is installed in an attic or a location requiring leak protection

OPTIONAL CONTROLS

iComfort® S30 Ultra-Smart Wi-Fi Thermostat (part of the iComfort® Residential Communicating Control System)

- Recognizes and connects to all iComfort® Communicating products to automatically configure and control the heating/cooling system (based on user-specified settings) for the highest level of comfort, performance and efficiency
- Recognizes model and serial number information for iComfort® Communicating products to simplify system setup
- Wi-Fi remote temperature monitoring and adjustment through a home wireless network for desktop PCs, laptops and apps for smartphones or tablets
- Service alerts and reminders sent via text message or e-mail
- Smart home automation compatible with Apple HomeKit™, Amazon Alexa®, Google Assistant and IFTTT
- Service Dashboard features online real-time monitoring of installed iComfort® Communicating systems
- Simple easy-to-use touchscreen allows complete system configuration
- Scheduled maintenance alerts, system warnings and troubleshooting are also displayed on thermostat screen
- Easy to read 7 inch high definition color display (measured diagonally)
- Conventional outdoor units (not iComfort® Communicating) can easily be added and controlled by the iComfort® S30 Thermostat
- Installer setup screens allow quick and simple system configuration without a manual, Installer can also run tests on complete system or individual components for easy maintenance and troubleshooting
- Serial communications bus (RSBus), with less wiring than a conventional heating/cooling system, allows system communication
- Uses 4-wire, 18-gauge standard thermostat wiring
- High Definition Color Display with Subbase, Smart Hub Controller, wallplate (for retrofit installations) furnished for easy installation
- See the iComfort® S30 Thermostat Product Specifications bulletin for more information



iComfort® E30 Smart Wi-Fi Thermostat

- Wi-Fi enabled, electronic 7-day, universal, multi-stage, programmable, touchscreen thermostat
- 3 Heat/2 Cool
- Auto-changeover
- Controls dehumidification during cooling mode and humidification during heating mode
- Offers enhanced capabilities including humidification / dehumidification / dewpoint measurement and control, Humiditol® control, and equipment maintenance reminders
- Easy to read 7 in. color touchscreen (measured diagonally)
- LCD display with backlight shows the current and set temperature, time, inside relative humidity, system status (operating mode and schedules) and outside temperature (optional outdoor sensor required)
- Smooth Setback Recovery starts system early to achieve setpoint at start of program period
- Compressor short-cycle protection (5 minutes)
- Up to four separate schedules are available plus Schedule IQ™
- One-Touch Away Mode - A quick and easy way to set the cooling and heating setpoints while away
- Smart Away™ - Uses geo-fencing technology to determine when the homeowner is within a predetermined distance from the home to operate the system when leaving, away and arriving
- Wi-Fi remote monitoring and adjustment through a home wireless network for desktop PCs, laptops and apps for smartphones or tablets
- Smart home automation compatible with Apple HomeKit™, Amazon Alexa®, Google Assistant and IFTTT
- High Definition Color Display with Subbase, Smart Hub Controller, wallplate (for retrofit installations) furnished for easy installation
- See the iComfort® E30 Smart Wi-Fi Thermostat Product Specifications bulletin for more information



OPTIONAL CONTROLS (continued)

Remote Outdoor Temperature Sensor

- Used with iComfort® Communicating thermostats
- When installed outdoors, sensor allows thermostat to display outdoor temperature

NOTE - Sensor is required for Enhanced Dehumidification Control (EDA) applications.



NOTE - The outdoor sensor is furnished as standard with iComfort® Communicating outdoor units, optional for conventional units.

NOTE - HCWHD3 Whole-Home Dehumidifiers are not iComfort® Communicating. The iComfort® humidity sensor can control the dehumidification features in the dehumidifier; however, it can not control zoning or ventilation.

NOTE - An iComfort® Communicating indoor unit (furnace or air handler) is required for proper operation with a conventional outdoor unit.

ComfortSense® 7500 Touchscreen Thermostat

- Electronic 7-day, universal, multi-stage, programmable, touchscreen thermostat
- 4 Heat/2 Cool
- Auto-changeover
- Dual-fuel control with optional outdoor sensor
- Controls dehumidification during cooling mode and humidification during heating mode
- Offers enhanced capabilities including humidification / dehumidification / dewpoint measurement and control, Humiditrol® control, and equipment maintenance reminders
- Easy-to-use, menu driven thermostat with a back-lit, LCD touchscreen
- See the ComfortSense® 7500 Product Specifications bulletin in the Controls section for more information



OPTIONAL ACCESSORIES

Whole-Home Dehumidistat



- Whole-Home Dehumidistat is used when access to the onboard control is unavailable (unit installation in an attic, crawlspace, etc.).
- LCD screen displays current relative humidity (%) and operation mode (On/Off).
- Up/Down arrow buttons allow setting dryness levels (1 to 7; 1 is least dry, 7 is most dry) in remote mode & % RH setting in external mode.
- Two modes of operation are available:
 - 1 - External - Measures humidity levels with an internal sensor on the control.
 - 2 - Remote - Measures humidity levels with the sensor on the dehumidifier.

Basement Kit

- Includes components typically needed for two-zone dehumidification.
- Includes two 10-in. normally open dampers, two 10-in. normally closed dampers and one 24V, 40VA transformer.

Ventilation and Zone Dampers

- Constructed of rolled galvanized steel with stiffening ribs to maintain rigidity. A single steel offset blade is attached to a one piece aluminium shaft connected with nylon bearings for smooth operation. Spring return with a normally closed or normally open configurations are available. Requires 24V transformer ordered separately.

Transformer

- 120V primary, 24V secondary, 40VA transformer for powering dampers.

Outdoor Air Temperature Sensor

- Prevents the HCWHD from using outside air for ventilation if the outdoor temperature is above 100°F or below 0°F. Connects directly to dehumidifier.

SPECIFICATIONS

Model No.		HCWHD3-070	HCWHD3-095	HCWHD3-130
Energy Star Qualified		No	No	Yes
Capacity		¹ 70 pints per day	² 95 pints per day	³ 130 pints per day
Energy Factor		¹ 2.0 L/kW-h	² 2.2 L/kW-h	³ 2.9L/kW-h
Capacity in Non-Rating Conditions		70°F / 60% RH = 55 ppd	70°F / 60% RH = 74 ppd	70°F / 60% RH = 99 ppd
		60°F / 60% RH = 40 ppd @ 155 cfm	60°F / 60% RH = 52 ppd @ 245 cfm	60°F / 60% RH = 72 ppd @310 cfm
Discharge Air Temperature Rise (°F)		10 - 30	10 - 30	10 - 30
Refrigerant		R-410A	R-410A	R-410A
Sound Level (dBA)	Ducted	47	54	50
	Unducted	51	58	54
Connections - in.	Drain diameter (PVC)	⁴ 3/4	⁴ 3/4	⁴ 3/4
	Duct diameter	10	10	10
Operating Conditions (temperature, RH)	Inlet Air	50°F - 104°F, 40°F dewpoint minimum	50 - 104°F, 40° dewpoint minimum	50 - 104°F, 40°F dewpoint minimum
	Installation (ambient)	40°F - 140°F, 0 - 99% (non-condensing)	40 - 140°F, 0 - 99% RH (non-condensing)	40 - 140°F, 0-99% RH (non-condensing)
Blower Data	Air Flow (external static pressure - dry coil)	155 cfm @ 0.0 in. w.c.	245 cfm @ 0.0 in. w.c.	310 cfm @ 0.0 in. w.c.
		115 cfm @ 0.2 in. w.c.	215 cfm @ 0.2 in. w.c.	270 cfm @ 0.2 in. w.c.
		70 cfm @ ⁵ 0.4 in. w.c.	185 cfm @ 0.4 in. w.c.	225 cfm @ 0.4 in. w.c.
		---	150 cfm @ ⁵ 0.6 in. w.c.	175 cfm @ 0.6 in. w.c.
		---	---	160 cfm @ ⁵ 0.7 in. w.c.
Filter	Type	Washable, MERV 8	Washable, MERV 8	Washable, MERV 8
	Size - in.	10 x 12 x 1	10 x 12 x 1	14 x 19 x 1
Shipping Weight - lbs.		76	79	122

ELECTRICAL DATA

	Line voltage data - 60 hz - 1ph	110/120V	110/120V	110/120V
	⁵ Maximum overcurrent protection (amps)	15	15	15
	⁵ Minimum Circuit Ampacity	8.42	11.23	11.51
	Rated amperage (amps)	¹ 6.3	² 8	³ 8.3
	Maximum normal operation amps	6.03	9.9	10.4
Compressor	Compressor rated load (amps)	6.45	8	9.4
	Compressor locked rotor (amps)	34	37	54
	Blower rated power (watts)	60	135	124
	Power connection	8 ft., 3-prong power cord		

¹ Rated capacity, Energy Factor test and current draw measured in accordance with AHAM DH-1 2008 at 80°F/60% RH inlet air at 155 cfm.

² Rated capacity, Energy Factor test and current draw measured in accordance with AHAM DH-1 2008 at 80°F/60% RH inlet air at 245 cfm.

³ Rated capacity, Energy Factor test and current draw measured in accordance with AHAM DH-1 2008 at 80°F/60% RH inlet air at 310 cfm.

⁴ Adaptor for threaded connection or plastic hose is furnished.

⁵ Refer to National or Canadian Electrical Code manual to determine wire, fuse and disconnect size requirements.

REQUIRED COMPONENTS			
Model No.	HCWHD3-070	HCWHD3-095	HCWHD3-130
Drain Pan - 36 x 36 in. (required for attic installations)	25P64	25P64	25P64
OPTIONAL ACCESSORIES			
Basement Kit - includes 2-10 in. NO dampers, 2-10 in. NC dampers, one 24V, 40VA transformer.	Y6451	Y6451	Y6451
Dampers Ventilation - 6 in. Normally Closed (NC)	X4152	X4152	X4152
Ventilation - 10 in Normally Closed (NC)	Y6483	Y6483	Y6483
Zone - 10 in. Normally Open (NO)	X4211	X4211	X4211
Damper Transformers Damper Transformer 24V, 40VA (hardwired, operates 1 damper only)	22N03	22N03	22N03
Damper Transformer 24V, 40VA (plug in, operates up to 4 dampers)	Y7128	Y7128	Y7128
OPTIONAL CONTROLS			
iComfort® S30 Ultra-Smart Wi-Fi Thermostat	19V30	19V30	19V30
Equipment Interface Module (EIM) - Required with iComfort® S30 Ultra-Smart Wi-Fi Thermostat (Dual-Fuel capable non-communicating heat pumps)	10T50	10T50	10T50
iComfort® E30 Smart Wi-Fi Thermostat	20A65	20A65	20A65
¹ Discharge Air Temperature Sensor	88K38	88K38	88K38
ComfortSense® 7500 Thermostat	13H14	13H14	13H14
² Remote Outdoor Air Temperature Sensor	X2658	X2658	X2658
¹ Discharge Air Temperature Sensor	88K38	88K38	88K38
ComfortSense® 7500 Thermostat	13H14	13H14	13H14
Whole-Home Dehumidistat	Y6456	Y6456	Y6456
³ Outdoor Air Temperature Sensor	58N66	58N66	58N66

¹ Optional for service diagnostics for communicating outdoor and indoor units (E30/S30 thermostats).

² Remote Outdoor Air Temperature Sensor allows the thermostat to display outdoor temperature.

³ Required for Automatic Ventilation Modes. Connects directly to dehumidifier.

HCWHD3-070 Dehumidifier Pressure/Airflow Curve
 Coil Dry, Air Filter Clean

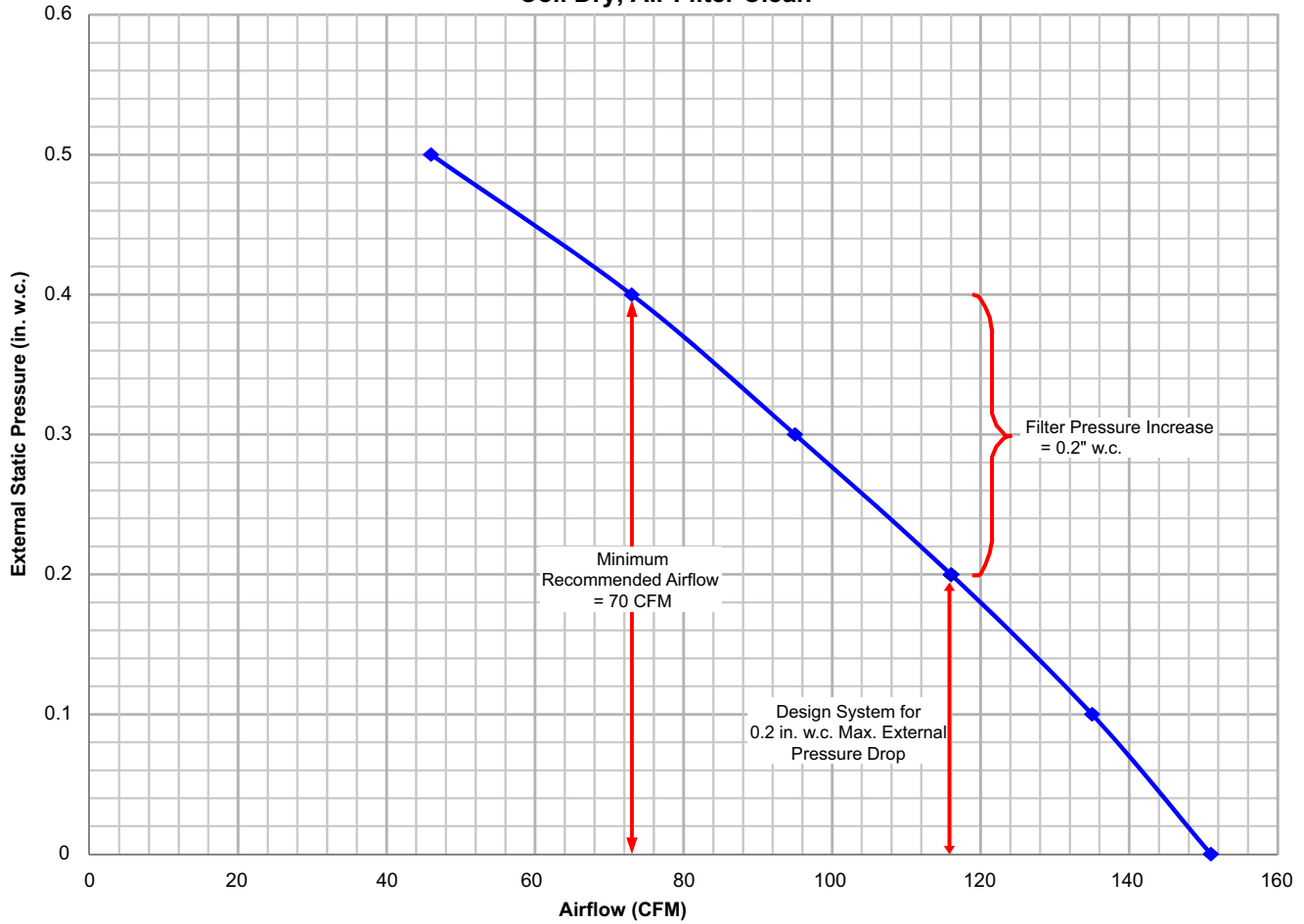

HCWHD3-095 Dehumidifier Pressure/Airflow Curve
 Coil Dry, Air Filter Clean

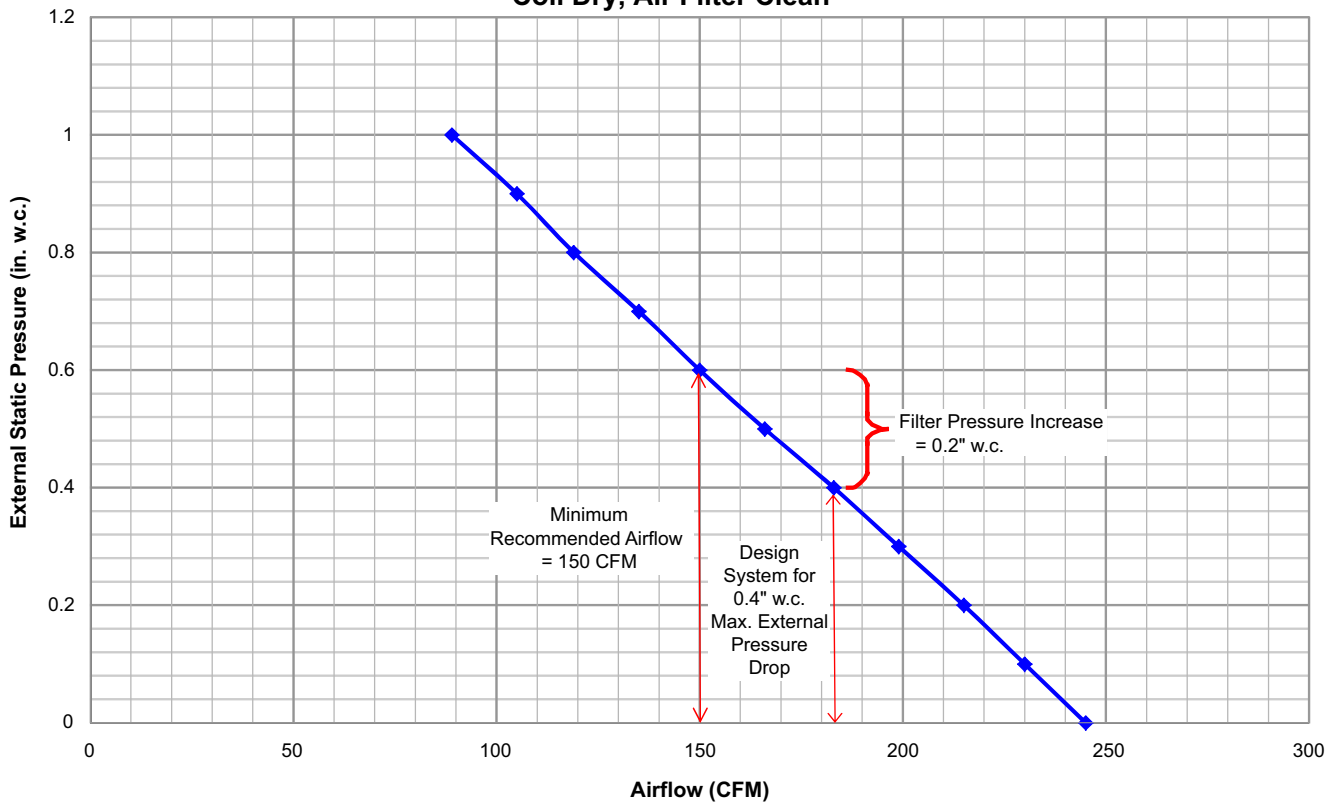

HCWHD3-130 Dehumidifier Pressure/Airflow Curve Coil Dry, Air Filter Clean

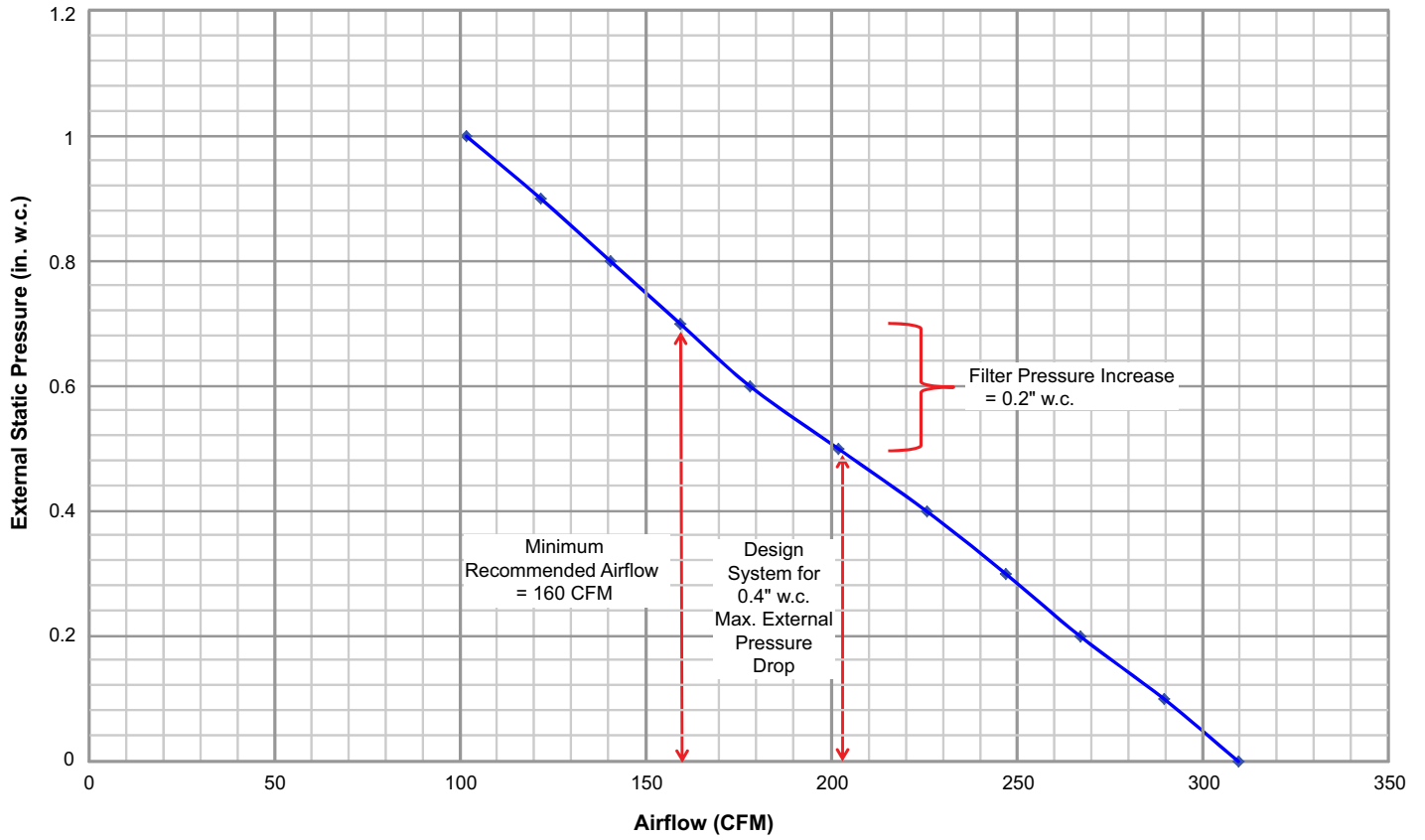

PERFORMANCE

HCWHD3-070 - CAPACITY - PINTS PER DAY

Relative Humidity	Temperature °F		
	60	70	80
60	40	55	70

HCWHD3-070 - ENERGY USE - PINTS PER KW/HR

Relative Humidity	Temperature °F		
	60	70	80
60	3.2	4.0	4.2

HCWHD3-070 - LEAVING AIR TEMPERATURE

Relative Humidity	Temperature °F		
	60	70	80
60	82	97	115

HCWHD3-070 - LEAVING AIR % RELATIVE HUMIDITY

Relative Humidity	Temperature °F		
	60	70	80
60	18	15	12

HCWHD3-070 - CAPACITY AND ENERGY USAGE VS. STATIC PRESSURE

Static Pressure - in. w.g.	0.0	0.3	0.4
Capacity - Pints Per Day	70	56	46
Energy Usage - Pints per kW/Hr	4.23	2.96	2.32

NOTE - Tested at 80°F/60% relative humidity.

HCWHD3-095 - CAPACITY - PINTS PER DAY

Relative Humidity	Temperature °F		
	60	70	80
60	52	74	95

HCWHD3-095 - ENERGY USE - PINTS PER KW/HR

Relative Humidity	Temperature °F		
	60	70	80
60	3.4	4.2	4.6

HCWHD3-095 - LEAVING AIR TEMPERATURE

Relative Humidity	Temperature °F		
	60	70	80
60	80	95	112

HCWHD3-095 - LEAVING AIR % RELATIVE HUMIDITY

Relative Humidity	Temperature °F		
	60	70	80
60	19	16	14

HCWHD3-095 CAPACITY AND ENERGY USAGE VS. STATIC PRESSURE

Static Pressure - in. w.g.	0	0.3	0.5	0.7
Capacity - Pints Per Day	95	91	86	79
Energy Usage - Pints per kW/Hr	4.71	4.23	3.89	3.49

NOTE - Tested at 80°F/60% relative humidity.

PERFORMANCE

HCWHD3-130 - CAPACITY - PINTS PER DAY

Relative Humidity	Temperature °F		
	60	70	80
60	72	99	130

HCWHD3-130 - ENERGY USE - PINTS PER KW/HR

Relative Humidity	Temperature °F		
	60	70	80
60	4.3	5.3	6.13

HCWHD3-130 - LEAVING AIR TEMPERATURE

Relative Humidity	Temperature °F		
	60	70	80
60	80	94	107

HCWHD3-130 - LEAVING AIR % RELATIVE HUMIDITY

Relative Humidity	Temperature °F		
	60	70	80
60	18	17	18

HCWHD3-130 CAPACITY AND ENERGY USAGE VS. STATIC PRESSURE

Static Pressure - in. w.g.	0	0.3	0.5	0.7
Capacity - Pints Per Day	130	121	103	83
Energy Usage - Pints per kW/Hr	6.13	5.30	4.12	3.05

NOTE - Tested at 80°F/60% relative humidity.

SIZING GUIDELINES

1. Find the home location (and corresponding region) in the map below
2. Estimate the air change rate of the home:
 - a. 1.00 air change per hour is an older home, that is not particularly tight.
 - b. 0.50 air change per hour is a reasonably tight home.
3. Determine how many dehumidifiers are required by comparing the actual home size and corresponding air change rate, to the "Maximum Recommended Home Size" in the table.
4. This is a general guideline. Consider any special circumstances that may require more water removal capacity and, if necessary, adjust your dehumidifier choice(s) accordingly.

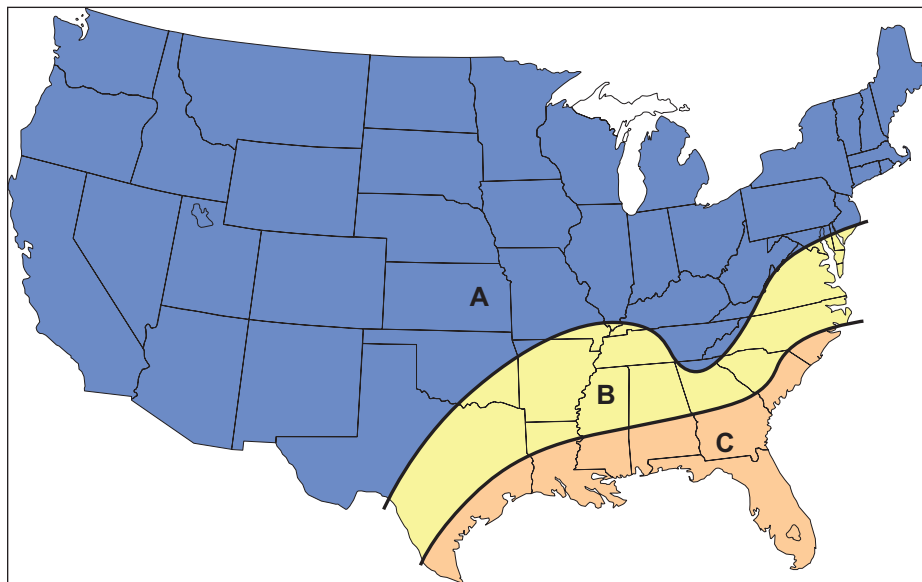

	HCWHD3-070		HCWHD3-095		HCWHD3-130	
	Air Change Per Hour (ACH)					
	1.00	0.50	1.00	0.50	1.00	0.50
	Maximum Recommended Home Size (sq. ft.)					
Region A	2800	3800	3800	5200	5200	7200
Region B	2200	3400	3000	4700	3900	6500
Region C	1400	2000	1900	2800	2300	3600

NOTES:

- Based on a single-story, slab construction home with four occupants.
- Dehumidistats set to less dry; thermostat set to auto-fan.
- Air conditioner with thermostat cooling set to at least 79°F.
- TMY 2 (Typical Meteorological Year) weather data; 1.00 lb./hr. internal moisture gain due to occupants.

DIMENSIONS

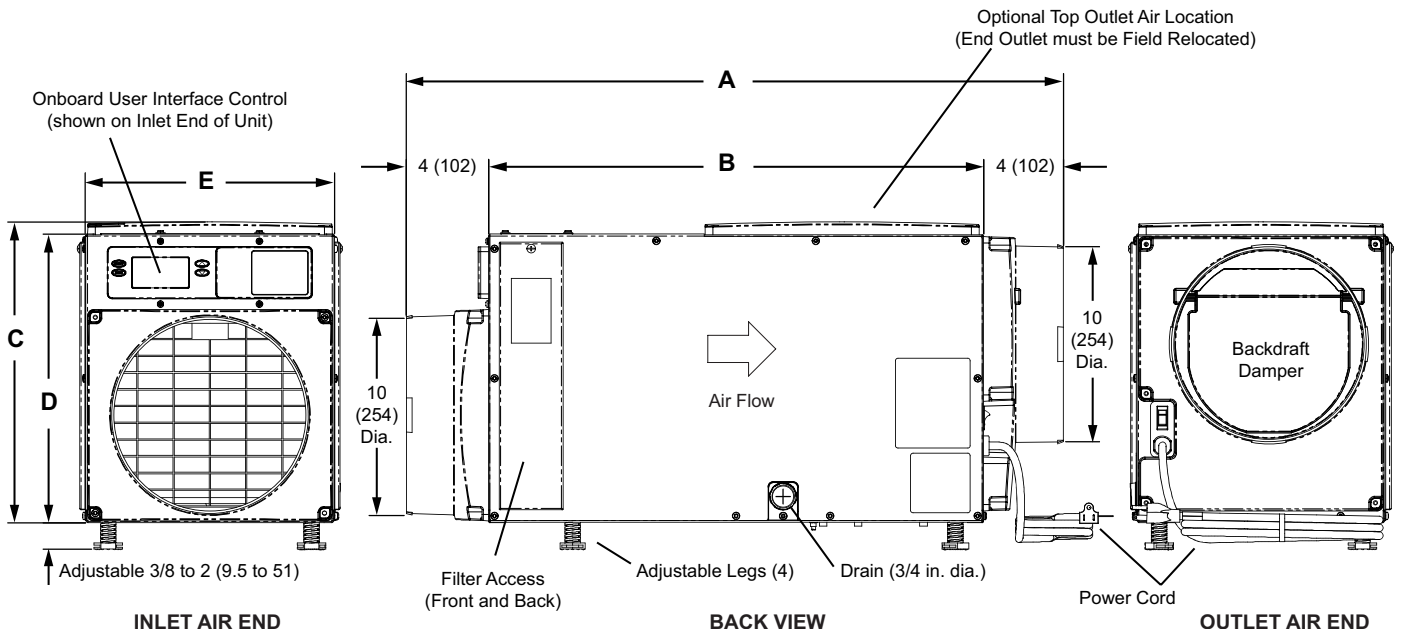

Model No.	A		B		C		D		E	
	in.	mm	in.	mm	in.	mm	in.	mm	in.	mm
HCWHD3-070	33	838	25	635	15-1/8	384	14-1/2	368	12-1/2	318
HCWHD3-095	35-1/2	902	27-1/2	699	15-1/8	384	14-1/2	368	12-1/2	318
HCWHD3-130	38	965	30	762	18-3/4	476	17-1/8	435	19-1/2	495

INSTALLATION CLEARANCES

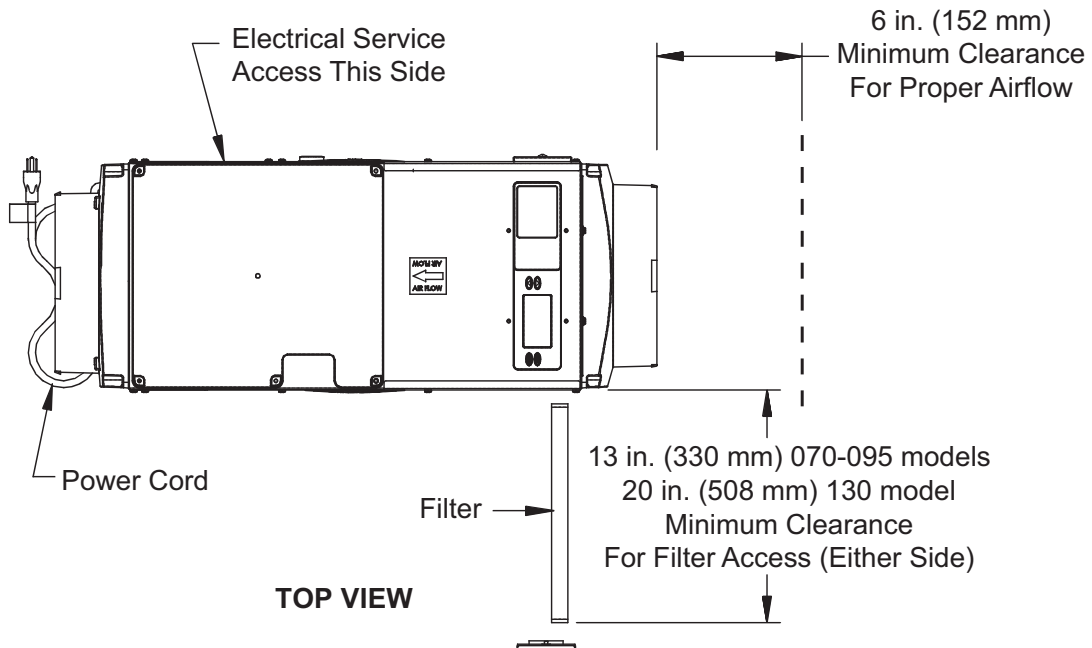

TYPICAL APPLICATIONS

BASEMENT DUCTING AND WIRING

Whole-Home Preferred Basement Installation

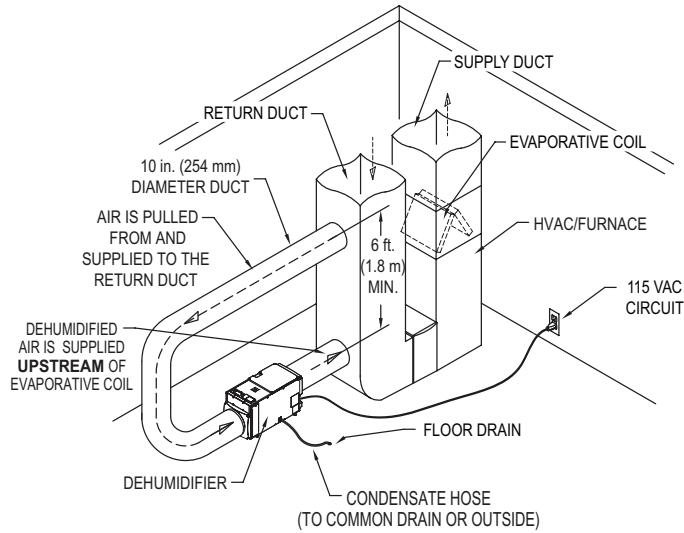

ATTIC DUCTING

Whole-Home Preferred Attic Installation

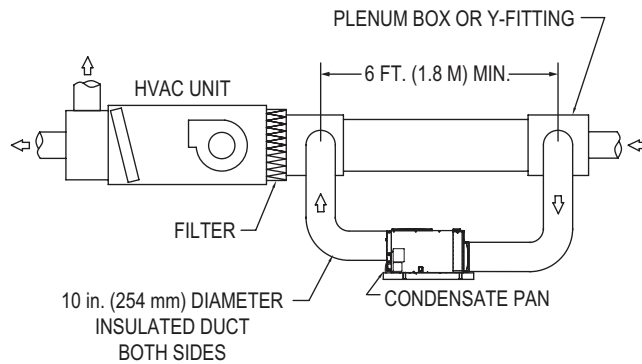

STANDALONE DUCTING AND WIRING

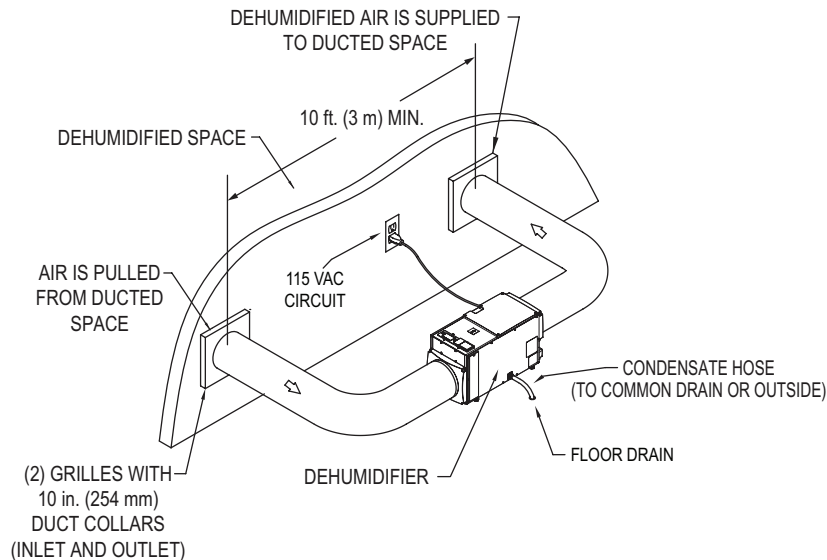

TYPICAL APPLICATIONS - PRIMARY AND SECONDARY ZONING

SECONDARY ZONING AND WIRING Whole-Home Primary Zone Installation

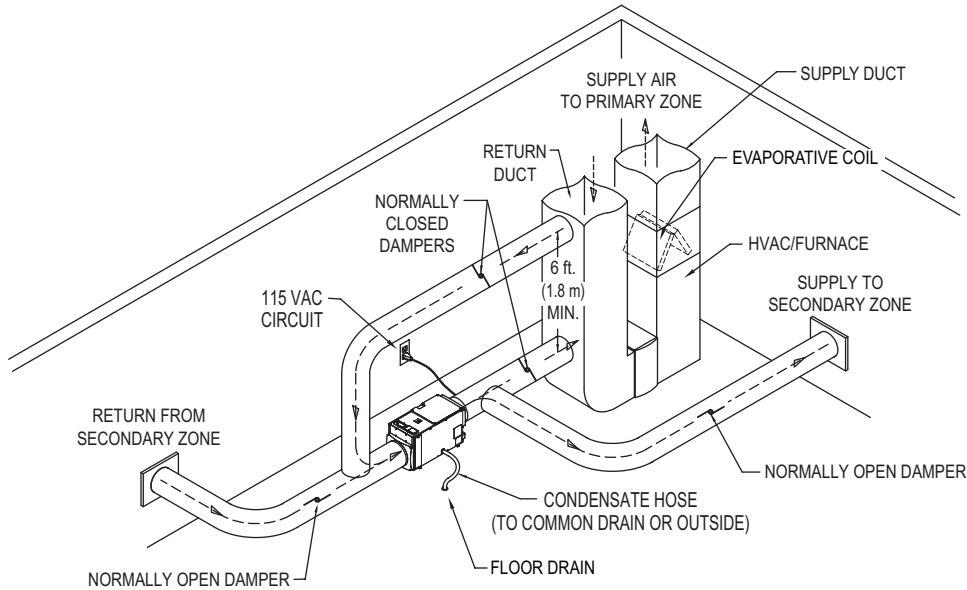

IMPORTANT - Normally Closed dampers must be installed in the ducts serving the Primary Zone and Normally Open dampers installed in the ducts serving the Secondary Zone.

PRIMARY ZONING AND WIRING Whole-Home Secondary Zone Installation

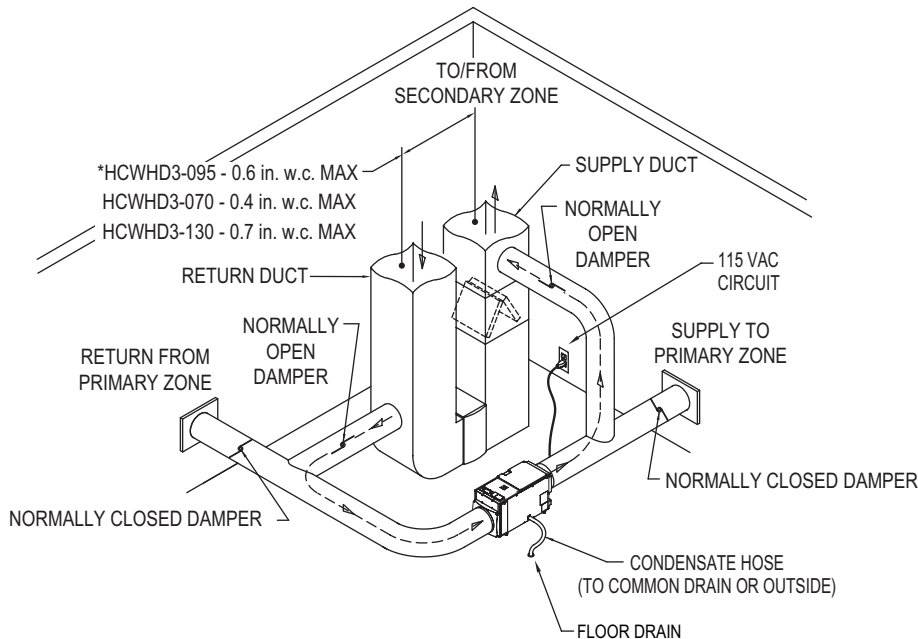

* NOTE - When the Whole-Home is the Secondary Zone, the ducting must be returned to supply. Make sure the external static pressure does not exceed the maximums shown and disable dehumidification during air conditioning operation.

IMPORTANT - Normally Closed dampers must be installed in the ducts serving the Primary Zone and Normally Open dampers installed in the ducts serving the Secondary Zone.

REVISIONS

Sections	Description of Change
Optional Accessories	Updated catalog numbers for S30 and E30 thermostats.



Visit us at www.lennox.com

For the latest technical information, www.LennoxPros.com

Contact us at 1-800-4-LENNOX

NOTE - Due to Lennox' ongoing commitment to quality, Specifications, Ratings and Dimensions subject to change without notice and without incurring liability. Improper installation, adjustment, alteration, service or maintenance can cause property damage or personal injury. Installation and service must be performed by a qualified installer and servicing agency.

©2020 Lennox Industries, Inc.