

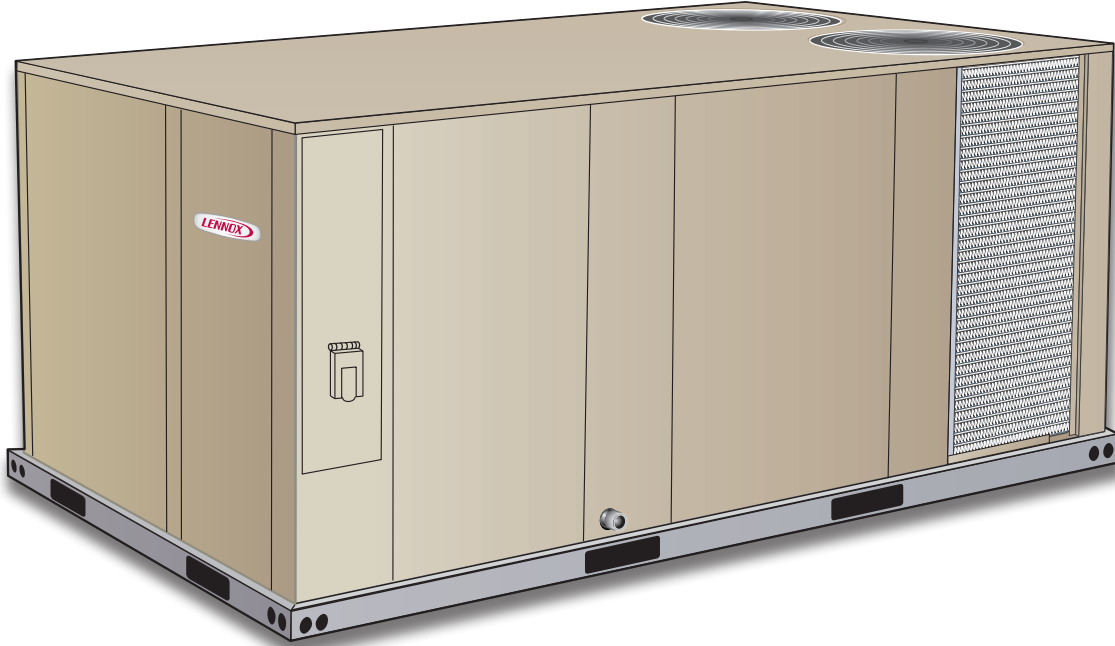

PRODUCT SPECIFICATIONS

Bulletin No. 210821
September 2019
Supersedes July 2019



7.5 to 12.5 Tons

Net Cooling Capacity – 86,000 to 142,000 Btuh
Optional Electric Heat - 7.5 to 60 kW

MODEL NUMBER IDENTIFICATION

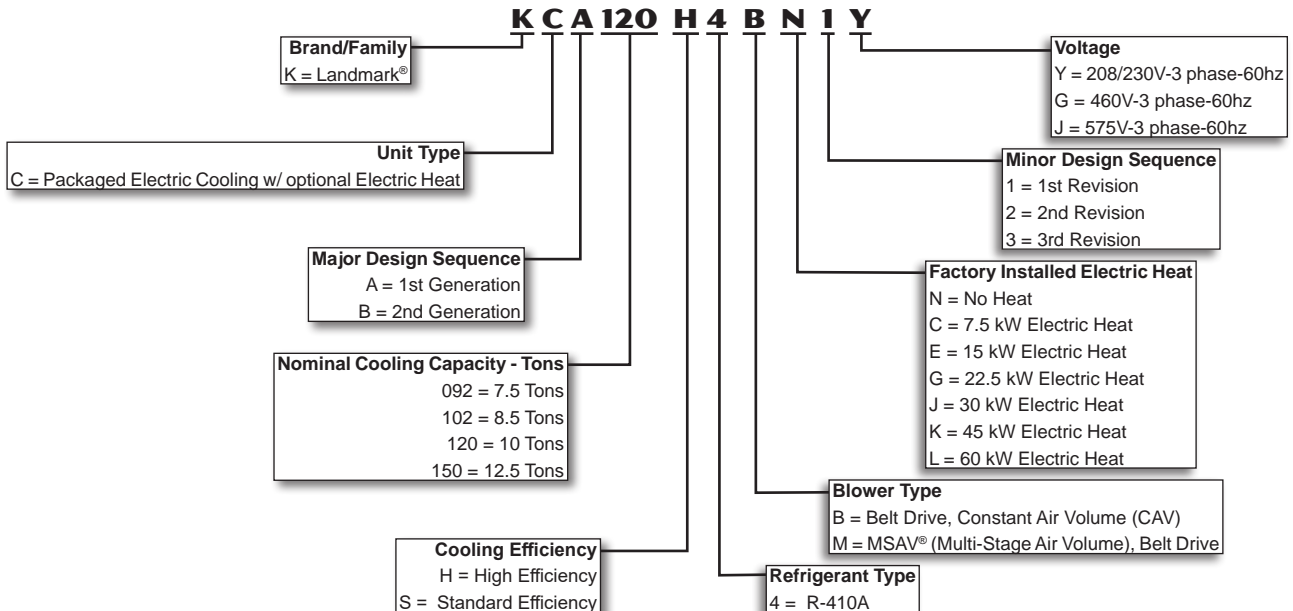

FEATURES AND BENEFITS

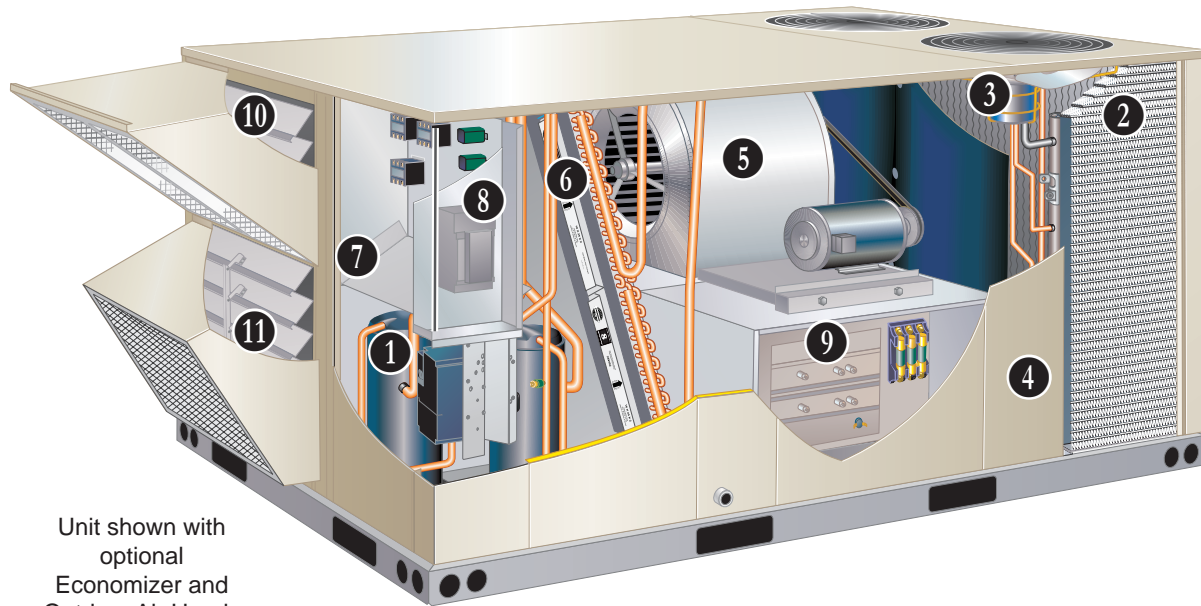

Unit shown with optional Economizer and Outdoor Air Hoods

Landmark® rooftop units from Lennox are the new standard for reliable, efficient rooftop units built for long-lasting performance that can significantly improve indoor environments. Landmark rooftop units feature:

- **R-410A Refrigerant** - Environmentally friendly.
- **Scroll Compressors** - Single speed scroll compressors are furnished on all models.
- **Lennox' Environ™ Coil System (092 - 120 Models Only)** - Smaller, lighter condenser coil.
- **Humiditrol® Dehumidification System (Standard Efficiency Models Only)** - Patented system allows for independent control of temperature and humidity, providing enhanced comfort control.
- **High Pressure Switches** - Protect compressor.
- **Isolated Compressor Compartment** - Allows performance check during normal compressor operation without disrupting airflow.
- **Independent Outdoor Fan Motor Mounts** - Allows for easy and efficient service access without removing the top panel.
- **Constant Air Volume (CAV) or MSAV® (Multi-Stage Air Volume) Supply Air Blower Option** - Allows constant or multi-staged air delivery.
- **Downflow or Horizontal Airflow** - Easy field conversion.
- **Two Fork Lift Slots on Three Sides** - Easy to pick up and transport units from almost any angle.
- **Corrosion-Resistant Removable, Reversible Drain Pan** - Provides application flexibility, durability and improved serviceability.
- **Thermostatic Expansion Valves (High Efficiency, 150S Models and all Standard Efficiency Models with Humiditrol®)** - Provide peak cooling performance across the entire application range.
- **MERV 8 or MERV 13 Filters** - Available as field installed option, provide an enhanced level of indoor air quality, and can help the building qualify for additional LEED credits.
- **Common Components** - Many maintenance items are standard throughout the entire product line, reducing the need to carry different parts to the job or maintain in inventory.

FEATURES AND BENEFITS

CONTENTS

Blower Data28
Dimensions - Accessories.44
Dimensions - Unit43
Electrical/Electric Heat Data33
Electric Heat Capacities.40
Features And Benefits	2
Humiditrol® Dehumidification System Ratings25
Model Number Identification	1
Optional Conventional Temperature Control Systems41
Options / Accessories10
Outdoor Sound Data27
Ratings17
Specifications13
Unit Clearances.40
Weight Data.42

APPROVALS

AHRI Certified to AHRI Standard 340/360.

ETL and CSA listed.

Efficiency rating verified by CSA.

Components bonded for grounding to meet safety standards for servicing required by UL, ULC and National and Canadian Electrical Codes.

All models are ASHRAE 90.1-2010 energy efficiency compliant and meet or exceed requirements of Section 6.8.

Models equipped with the MSAV blower option meet California Code of Regulations, Title 24 and ASHRAE 90.1-2010 Section 6.4.3.10 requirements for staged airflow.

ISO 9001 Registered Manufacturing Quality System.

WARRANTY

Limited five years on compressors.

Limited three years on the Lennox' Environ™ Coil System.

Limited five years Optional High Performance Economizers.

Limited one year all other covered components.

COOLING SYSTEM

Designed to maximize sensible and latent cooling performance at design conditions.

System can operate from 30°F to 125°F without any additional controls.

R-410A Refrigerant

Non-chlorine based, ozone friendly, R-410A.

1 Scroll Compressors

Scroll compressors on all models for high performance, reliability and quiet operation.

Resiliently mounted on rubber grommets for quiet operation.

Compressor Crankcase Heaters

Protects against refrigerant migration that can occur during low ambient operation.

Thermal Expansion Valves (All High Efficiency Models, 150S Model and all Standard Efficiency Models with Humiditrol®)

Assures optimal performance throughout the application range.

Removable element head.



Refrigerant Metering Orifice (092 through 120 Standard Efficiency Models)

Accurately meters refrigerant in system.

Refrigerant control is accomplished by exact sizing of refrigerant metering orifice.

Filter/Driers

High capacity filter/drier protects the system from dirt and moisture.

High Pressure Switches

Protects the compressor from overload conditions such as dirty condenser coils, blocked refrigerant flow, or loss of outdoor fan operation. Auto-reset.

Freezestats

Protects the evaporator coil from damaging ice build-up due to conditions such as low/no airflow, or low refrigerant charge.

2 Lennox' Environ™ Coil System (092 through 120 models only)

Condenser coil features lightweight, all aluminum brazed fin construction.

Constructed of three components:

a flat extrusion tube, fins in-between the flat extrusion tube and two refrigerant manifolds.

Environ™ Coil System Features:

- Improved heat transfer performance due to high primary surface area (flat tubes) versus secondary surface (fins).
- Smaller internal volume (reduced refrigerant charge).
- High durability (all aluminum construction).
- Fewer brazed joints.
- Compact design (reduces unit weight).
- Easy maintenance/cleaning.

Face-split design.

Mounting brackets with rubber inserts secure coil to unit providing vibration dampening and corrosion protection.

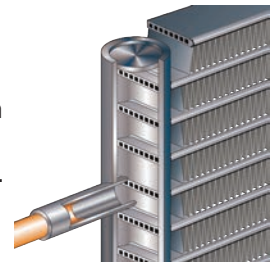

FEATURES AND BENEFITS

COOLING SYSTEM **(continued)**

Conventional Fin/Tube Condenser Coils **(furnished on 150 models, optional for 092-120)**

Copper tube construction, enhanced rippled-edge aluminum fins, flared shoulder tubing connections, silver soldered construction.

Evaporator Coil

Copper tube construction, enhanced rippled-edge aluminum fins, flared shoulder tubing connections, silver soldered construction for improved heat transfer.

Cross row circuiting with rifled copper tubing optimizes both sensible and latent cooling capacity.

Condensate Drain Pan

Plastic pan, sloped to meet drainage requirements of ASHRAE 62.1.

Side or bottom drain connections.

Reversible to allow connection at back of unit.

Outdoor Coil Fan Motors

Thermal overload protected, totally enclosed, permanently lubricated ball bearings, shaft up, wire basket mount.

3 Outdoor Coil Fans

PVC coated fan guard furnished.

Required Selections

Cooling Capacity

Specify nominal cooling capacity of the unit.

Cooling Efficiency

Specify either standard or high efficiency.

Options/Accessories

Factory Installed

Conventional Fin/Tube Condenser Coil (replaces Environ™ Coil System - 092 through 120 models only)

Copper tube construction, enhanced rippled-edge aluminum fins, flared shoulder tubing connections, silver soldered construction.

Landmark® Packaged Electric / Electric 7.5 to 12.5 Ton / Page 4

*NOTE - Required if Humiditrol®
Dehumidification System is
ordered.*

Field Installed

Condensate Drain Trap

Available in copper or PVC.

Drain Pan Overflow Switch

Monitors condensate level in drain pan, shuts down unit if drain becomes clogged.

Low Ambient Controls

Units operate satisfactorily down to 45°F outdoor air temperature without any additional controls.

Two low ambient control options are available for field installation:

1. **Low Ambient Control Kit (30°F)** - Allows unit operation down to 30°F.
2. **Low Ambient Control Kit (0°F)** - Allows unit operation down to 0°F without evaporator coil icing. Head pressure speed control reduces outdoor fan operation during low ambient conditions until head pressure rises to the setpoint. Pressure transducers are mounted on the liquid lines. High pressure switches are furnished to replace existing. Wiring harnesses are furnished for simple plug-in wiring to fans and controller.

CABINET

4 Construction

Heavy-gauge steel panels and full perimeter heavy-gauge galvanized steel base rail provides structural integrity for transportation, handling, and installation.

Base rails have rigging holes.

Three sides of the base rail have forklift slots.

Raised edges around duct and power entry openings in the bottom of the unit provide additional protection against water entering the building.

Airflow Choice

Units are shipped in downflow (vertical) configuration, can be field converted to horizontal airflow with optional Horizontal Discharge Kit.

Duct Flanges

Provided for horizontal duct attachment.

Power Entry

Electrical lines can be brought through the unit base or through horizontal access knock-outs

Exterior Panels

Constructed of heavy-gauge, galvanized steel with a two-layer enamel paint finish.

Insulation

All panels adjacent to conditioned air are fully insulated with non-hygroscopic fiberglass insulation.

Unit base is fully insulated. The insulation also serves as an air seal to the roof curb, eliminating the need to add a seal during installation.

Access Panels

Access panels are provided for the filter section, heating/blower section, and the compressor/controls section.

Options/Accessories

Factory Installed

Corrosion Protection

A completely flexible immersed coating with an electrodeposited dry film process. (AST ElectroFin E-Coat) Meets Mil Spec MIL-P-53084, ASTM B117 Standard Method Salt Spray Testing.

Indoor Corrosion Protection:

- Coated coil
- Coated reheat coil (Humiditrol®)
- Painted blower housing
- Painted base

Outdoor Corrosion Protection:

- Coated coil
- Painted base

FEATURES AND BENEFITS

CABINET (continued)

Options/Accessories

Factory Installed

Hinged Access Panels

Large access panels are hinged and have quarter-turn latches for quick and easy access to maintenance areas (filter, compressor / controls, heating / blower).

Field Installed

Combination Coil/Hail Guards

Heavy gauge steel frame painted to match cabinet with expanded metal mesh to protect the outdoor coil from damage.

Horizontal Discharge Kit

Consists of duct covers to block off downflow supply and return air openings for horizontal applications.

Also includes return air duct flanges for end return air when economizer is used in horizontal applications.

NOTE - When configuring unit for horizontal application with economizer, a separate Horizontal Barometric Relief Damper with Hood must be ordered separately for installation in the return air duct.

Return Air Adaptor Plate

For same size LC/LG/LH and TC/TG/TH unit replacement.

Installs on return air opening in unit to match return air opening on existing roof curbs. Also see Accessory Air Resistance table.

5 BLOWER

A wide selection of supply air blower options are available to meet a variety of airflow requirements.

Motor

Overload protected, equipped with ball bearings. Belt drive motors are offered on all models and are available in several different sizes to maximize air performance.

Supply Air Blower

Forward curved blades, double inlet, blower wheel is statically and dynamically balanced. Equipped

with ball bearings and adjustable pulley (allows speed change).

Blower assembly slides out of unit for servicing.

Required Selections

Select Constant Air Volume (CAV) or MSAV® (Multi-Stage Air Volume) Blower Option

Order blower motor horsepower and drive kit number required when base unit is ordered, see Drive Kit Specifications Table.

CAV Operation

On units ordered with the Constant Air volume (CAV) option, the supply air blower will provide a constant volume of air.

MSAV Operation

Units ordered with the MSAV option utilize a Variable Frequency Drive (VFD) to stage the supply air blower airflow. The VFD alters the frequency and voltage of the power supply to the blower to control blower speed.

The supply air blower has two speeds:

- Low speed for part-load cooling operation. Note - Low speed is 66% of high speed.
- High speed for full load cooling and all heat modes.

Full speed blower operation is set by adjusting the motor pulley to deliver the desired air volume.

The ventilation speed is selectable between high and low speed.

NOTE - Part load airflow in cooling mode on MSAV units should not be set below 220 cfm/nominal full load ton to reduce the risk of evaporator coil freeze-up.

The VFD has an operational range of -40 to 125° F outdoor air ambient temperature.

Lower operating costs are obtained when the blower is operated on lower speeds.

MSAV Sequence of Operation

Ventilation speed is determined by the VENT SPEED switch setting on VFD control board (LO or HI).

Blower operates in low speed for mechanical cooling (Y1).

Blower operates in high speed for any other mode (free cooling, mechanical cooling Y1+Y2, and heating).

Economizer damper minimum position is fully closed in unoccupied mode.

In occupied mode, the economizer damper minimum position is determined by the setting of the two potentiometers on VFD control board.

- LO SPD MIN POS potentiometer sets the minimum position when blower is operating at low speed.
- HI SPD MIN POS potentiometer sets the minimum position when blower is operating at high speed.

Options/Accessories

Field Installed

VFD Manual Bypass Kit

VFD Manual Bypass Control is available as a kit for units equipped with the MSAV option.

The VFD Manual Bypass Control is a manual bypass and is enabled by re-configuring the wiring on the unit.

INDOOR AIR QUALITY

6 Air Filters

Disposable 2 inch filters furnished as standard.

Options/Accessories

Field Installed

Healthy Climate® High Efficiency Air Filters

Disposable MERV 8 or MERV 13 (Minimum Efficiency Reporting Value based on ASHRAE 52.2) efficiency 2 inch pleated filters.

Replacement Filter Media Kit With Frame

Replaces existing pleated filter media. Includes washable metal mesh screen and metal frame with clip for holding replaceable non-pleated filter.

FEATURES AND BENEFITS

INDOOR AIR QUALITY (continued)

Options/Accessories

Field Installed

Healthy Climate® UVC Germicidal Lamps



Germicidal lamps emit ultra-violet (UV-C) energy, which has been proven to be effective in reducing microbes such as viruses, bacteria, yeasts, and molds. This process either destroys the organism or controls its ability to reproduce.

UV-C energy greatly reduces the growth and proliferation of mold and other bioaerosols (bacteria and viruses) on illuminated surfaces (particularly coil and drain pan).

Lamps are field installed in the blower/evaporator coil section.

All necessary hardware for installation is included.

Lamps operate on 208/230V power supply. Step-down transformer must be field supplied when used with 460V and 575V rooftop units.

Magnetic safety interlock terminates power when access panels are removed.

Approved by ETL.

Indoor Air Quality (CO₂) Sensors

Monitors CO₂ levels, reports to the Unit Controller which adjusts economizer dampers as needed.

CONTROLS

7 Unit Control

All control voltage is provided via a 24V (secondary) transformer with built-in circuit breaker protection.

Heat/Cool Staging - Capable of up to 2 heat / 2 cool staging with a third party DDC control system or thermostat.

Low Voltage Terminal Block - Provides screw terminal connections for thermostat or controller wiring.

Night Setback Mode - Saves energy by closing outdoor air dampers and operating supply fan on thermostat demand only.

Options/Accessories

Field Installed

Smoke Detector

Photoelectric type, installed in supply air section, return air section or both sections. Available with power board and single sensor (supply or return) or power board and two sensors (supply and return).

Commercial Control Systems

L Connection® Network

Complete building automation control system for single or multi-zone applications. Options include local interface, software for local or remote communication, and hardware for networking other control functions.

See L Connection Network Product Specifications Bulletin for details.

NOTE - Not available for *Humiditrol*® equipped units.

Thermostats

Control system and thermostat options, see page 41.

ELECTRICAL

Marked & Color-Coded Wiring

All electrical wiring is color-coded and marked to identify which components it is connecting.

Electrical Plugs

Positive connection electrical plugs are used to connect common accessories or maintenance parts for easy removal or installation.

Phase Monitor (Factory Installed on Units Equipped with the MSAV® Supply Air Blower Option)

Phase monitor located in the control compartment detects the phasing of incoming power. If the incoming power is out of phase or if any of the three phases are lost, an indicator LED on the phase monitor will turn red and the unit will not start. In normal operation with correct incoming power phasing, the LED will be green.

Required Selections

Voltage Choice

Specify when ordering base unit.

Options/Accessories

Factory or Field Installed

8 Disconnect Switch

Accessible from outside of unit, spring loaded weatherproof cover furnished. Main power to the unit is field connected to the disconnect which allows all power to be shut off for service. See Electrical/Electric Heat tables for ordering information, page 33.

9 Electric Heat

Helix wound nichrome elements, individual element limit controls, wiring harness. Unit fuse block is furnished as standard. See Options / Accessories tables for ordering information.

NOTE - Factory installed electric heat is only available with high efficiency models.

GFI Service Outlets (2)

115V ground fault circuit interrupter (GFCI) type, non-powered, field-wired.

Field Installed

GFI Weatherproof Cover

Single-gang cover.

Heavy-duty UV-resistant polycarbonate case construction.

Hinged base cover with gasket.

OPTIONS / ACCESSORIES

ECONOMIZER OPTIONS

Factory or Field Installed

10 Economizer (Standard and High Performance Common Features)

Downflow or Horizontal with Outdoor Air Hood and Barometric Relief Dampers with Exhaust Hood.

11 Barometric Relief Dampers allow relief of excess air, aluminum blade dampers prevent blow back and outdoor air infiltration during off cycle, bird screen furnished.

NOTE - Optional Horizontal Low Profile Barometric Relief Dampers with Exhaust Hood are available for field installation in a reduced space.

Occupied/Unoccupied mode with field furnished setback thermostat.

Demand Control Ventilation (DCV) ready using optional CO₂ sensors.

Mixed Air Sensor is furnished for field installation in the rooftop unit. Sensor is factory installed when Economizers are factory installed.

Single sensible sensor is furnished with Economizer and enables economizer operation if the outdoor temperature is less than the setpoint of the control.

Standard Economizer Features (Not for Title 24)

Gear-driven action, return air and outdoor air dampers, plug-in connections to unit, nylon bearings, neoprene seals, 24-volt, fully-modulating spring return motor.

Standard Economizer Control Module

The Standard Economizer Control Module can be adjusted to operate based on outdoor air temperatures.



Economizer Controls:

- Damper Minimum Position - Can be set lower than traditional minimum air requirements resulting in cost savings.

- IAQ Sensor - Signals dampers to modulate and maintain 55°F when CO₂ is higher than the CO₂ setpoint.
- Demand Control Ventilation (DCV) LED - A steady green Demand Control Ventilation LED indicates the IAQ reading is higher than setpoint and requires more fresh air.
- Free Cool LED - A steady green LED indicates outdoor air is suitable for free cooling.

Free Cooling runs when outdoor air temperature is lower than the set temperature on the economizer control.

NOTE: The Free Cooling default setting for outdoor air temperature sensor is 55°F.

High Performance Economizer Features

Approved for California Title 24 building standards.

Low leakage dampers are Air Movement and Control Association International (AMCA) Class 1A Certified - Maximum 3 CFM per sq. ft. leakage at 1 in. w.g.

ASHRAE 90.1-2010 compliant.

Gear-driven action, high torque 24-volt fully-modulating spring return damper motor, return air and outdoor air dampers, plug-in connections to unit, stainless steel bearings, enhanced neoprene blade edge seals and flexible stainless steel jamb seals to minimize air leakage.

NOTE - High Performance Economizers are not approved for use with enthalpy controls in Title 24 applications.

NOTE - The Free Cooling setpoint for Title 24 applications must be set based on the Climate Zone where the system is installed. See Section 140.4 "Prescriptive Requirements for Space Conditioning Systems" of the California Energy Commission's 2013 Building Energy Efficiency Standards.

Refer to Installation Instructions for complete setup information and menu parameters available.

High Performance Economizer Control Module

Module provides inputs and outputs to control economizer based on parameter settings.



Module automatically detects sensors by polling to determine which sensors are installed in system.

Module displays any alarm messages (fault detection and diagnostics) as an aid in troubleshooting.

Non-volatile memory retains parameter settings in case of power failure.

Keypad with four navigation buttons and LCD screen is furnished for setting economizer parameters.

- Menu Up/Exit (↑) button returns to the main menu.
- Arrow Up (▲) button moves to the previous or next parameter within the selected menu.
- Arrow Down (▼) button moves to the next parameter within the selected menu.
- Select (enter) (↵) button confirms parameter selection.

Main Menu Structure:

- STATUS (economizer and system operation status)
- SETPOINTS (settings for various setpoint parameters)
- SYSTEM SETUP (settings/information about the system)
- ADVANCED SETUP (freeze protection, CO₂ settings, stage 3 delay and additional calibration settings)
- CHECKOUT (damper positions)
- ALARMS (output signal that can be configured for remote alarm monitoring)

OPTIONS / ACCESSORIES

ECONOMIZER OPTIONS

(continued)

Factory or Field Installed

Single Enthalpy Temperature Control

(Not for Title 24)

Outdoor air enthalpy sensor enables Economizer if the outdoor enthalpy is less than the setpoint of the control.

Field Installed

Differential Enthalpy Control (Not for Title 24)

Order two Single Enthalpy Controls. One is field installed in the return air section, the other in the outdoor air section. Allows the economizer control board to select between outdoor air or return air, whichever has lower enthalpy.

EXHAUST OPTIONS

Field Installed

Horizontal Low Profile Barometric Relief Dampers

Replaces barometric relief dampers furnished with Economizer.

For use when unit is configured for horizontal applications in a reduced space requiring an economizer.

Allows relief of excess air.

Aluminum blade dampers prevent blow back and outdoor air infiltration during off cycle.

Field installed in return air duct.

Exhaust hood with bird screen furnished.

Requires Horizontal Discharge Kit.

Power Exhaust Fan

Installs internal to unit for downflow applications only with economizer option. Provides exhaust air pressure relief. Interlocked to run when supply air blower is operating, fan runs when outdoor air dampers are 50% open (adjustable), motor is overload protected. Requires Economizer with Outdoor Air Hood and Barometric Relief Dampers. Fan is 20 in. diameter with 5 blades (K1PWRE10B) WITH 1/3 hp motor.

OUTDOOR AIR OPTIONS

Factory or Field Installed

Outdoor Air Damper - Downflow or Horizontal With Air Hood

Linked mechanical dampers, 0 to 25% (fixed) outdoor air adjustable, installs in unit. Includes outdoor air hood.

Automatic model features fully modulating spring return damper motor with plug-in connection.

Manual model features a slide damper.

Maximum mixed air temperature in cooling mode: 100°F.

ROOF CURBS

Nailer strip furnished, mates to unit, US National Roofing Contractors Approved, shipped knocked down.

Hybrid Roof Curbs, Downflow

Roof curb can be assembled using interlocking tabs to fasten corners together. No tools required.

Curb can also be fastened together with furnished hardware.

Available in 8, 14, 18, and 24 inch heights.

Adjustable Pitch Curb

Fully adjustable pitch curbs (3/4 in. per foot in any direction) provide a level platform for rooftop units allowing flexible installations on roofs with uneven or sloped angles.

Uses interlocking tabs to fasten corners together. No tools required.

Hardware is furnished to connect upper curb with lower curb.

Available in 14 inch height.

Adaptor Curbs (not shown)

Curbs are regionally sourced. Dimensions will vary based upon the source. Contact your local sales representative for a detailed cut sheet with applicable dimensions.

CEILING DIFFUSERS

Ceiling Diffusers (Flush or Step-Down)

Diffuser face and grilles with white powder coat finish, insulated (UL listed duct liner), diffuser box with collars for duct connection, fixed blades (flush diffusers) and double deflection blades (step-down diffusers), provisions for suspending, internally sealed (prevents recirculation), removable return air grille, adapts to T-bar ceiling grids or plaster ceilings.

Transitions (Supply and Return)

Used with diffusers, installs in roof curb, galvanized steel construction, flanges furnished for duct connection to diffusers, fully insulated.

OPTIONS / ACCESSORIES

HUMIDITROL® DEHUMIDIFICATION SYSTEM

NOTE - Not available with Environ™ Coil System. Conventional Fin/Tube condenser coil must be ordered as a factory option.

Factory installed option designed to control humidity.

Provides dehumidification on demand using ASHRAE 90.1 recommended method for comfort conditioning humidity control.

Unit comes equipped with one row reheat coil, solenoid valve and humidity controller.

A thermostat with a dehumidification output, a dehumidistat, or a DDC controller with an isolated output is required to control humidity and must be located in the occupied space.

Benefits

Improves indoor air quality.

Helps prevent damage due to high humidity levels.

Improves comfort levels by reducing space humidity levels.

OPERATION

No Dehumidification Demand

The unit will operate conventionally whenever there is a demand for cooling or heating and no dehumidification demand.

Free cooling is only permitted when there is no demand for dehumidification.

Dehumidification Demand Only

Dehumidification is initiated by an output from a dehumidistat (furnished), an optional thermostat with a dehumidification output or an optional DDC controller with an isolated output to control humidity.

Reheat operation will initiate on a dehumidification demand and does not require a cooling demand.

The unit will operate in the dehumidification mode until the relative humidity of the conditioned space is below the setpoint.

This operation reduces sensible cooling capacity and extends compressor run time to control humidity when the cooling load is low.

A solenoid valve diverts hot gas from the compressor to the reheat coil.

The cooled and dehumidified air from the evaporator is reheated as it passes through the reheat coil.

The de-superheated and partially condensed refrigerant continues to the outdoor condenser coil where condensing is completed. The unit will continue to operate in this mode until the dehumidification demand is satisfied.

Dehumidistat Furnished

Furnished for field installation

Remote mounted dehumidistat for factory installed *Humiditrol*® option. Adjustable 20-80%.

NOTE - A thermostat with a dehumidification output or a DDC controller with an isolated output can be used instead.

See Conventional Thermostat Control Systems on page 41 for additional Humiditrol® control options.

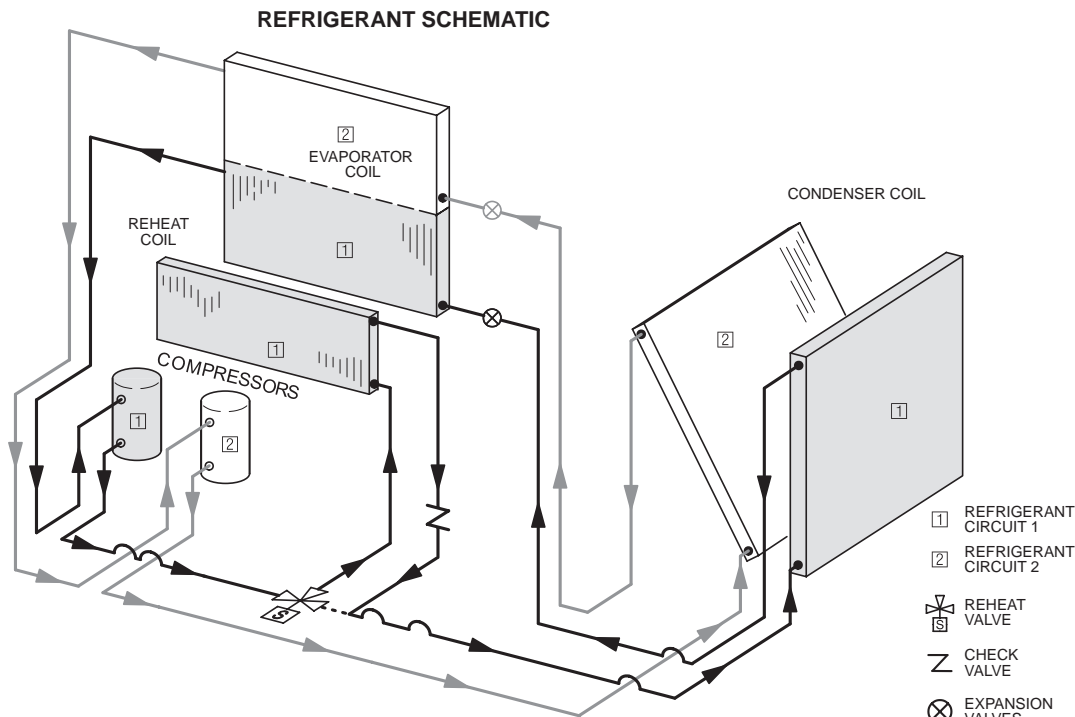

OPTIONS / ACCESSORIES

Item Description	Model Number	Catalog Number	Unit Model No			
			092	102	120	150
COOLING SYSTEM						
Condensate Drain Trap	PVC - C1TRAP20AD2	76W26	X	X	X	X
	Copper - C1TRAP10AD2	76W27	X	X	X	X
Conventional Fin/Tube Condenser Coil (Replaces Environ™ Coil System) (Required for Humiditrol® option)		Factory	O	O	O	
Corrosion Protection		Factory	O	O	O	O
Drain Pan Overflow Switch	K1SNSR71AB1-	74W42	X	X	X	X
Efficiency		High	O	O	O	O
		Standard	O	O	O	O
Low Ambient Kits	30°F - K1SNSR33B-1	54W16	X	X	X	X
	0°F - K1LOAM62B-1	18B87	X	X	X	
	0°F - K1LOAM62BS1	18B94				X
Refrigerant Type		R-410A	O	O	O	O
BLOWER - SUPPLY AIR						
Blower Option	CAV (Constant Air Volume)	Factory	O	O	O	O
	MSAV® (Multi-Stage Air Volume)	Factory	O	O	O	O
Blower Motors	Belt Drive - 2 hp	Factory	O	O	O	O
	Belt Drive - 3 hp	Factory	O	O	O	O
	Belt Drive - 5 hp	Factory	O	O	O	O
VFD Manual Bypass Kit (for MSAV® equipped units only)	KVFDB12C-1	90W53	X	X	X	X
Drive Kits	Kit #1 590-890 rpm	Factory	O	O	O	O
See Blower Data Tables for selection	Kit #2 800-1105 rpm	Factory	O	O	O	O
	Kit #3 795-1195 rpm	Factory	O	O	O	O
	Kit #7 730-970 rpm	Factory	O	O	O	O
	Kit #8 940-1200 rpm	Factory	O	O	O	O
	Kit #9 1015-1300 rpm	Factory	O	O	O	O
	Kit #10 900-1135 rpm	Factory	O	O	O	O
	Kit #11 1040-1315 rpm	Factory	O	O	O	O
	Kit #12 1125-1425 rpm	Factory	O	O	O	O
	CABINET					
	Combination Coil/Hail Guards	C1GARD52B-1	13T05	X	X	X
Hinged Access Panels		Factory	O	O	O	O
Horizontal Discharge Kit	K1HECK00B-1	51W25	X	X	X	X
Return Air Adaptor Plate (for LC/LG/LH and TC/TG/TH unit replacement)	C1CONV10B-1	54W96	X	X	X	X
CONTROLS						
NOTE - Also see Conventional Thermostat Control Systems page 40 for Additional Options.						
Smoke Detector - Supply or Return (Power board and one sensor)	C1SNSR44B-2	11K76	X	X	X	X
Smoke Detector - Supply and Return (Power board and two sensors)	C1SNSR43B-2	11K80	X	X	X	X
L Connection® Building Automation System		- - -	X	X	X	X

NOTE - Catalog and model numbers shown are for ordering field installed accessories.

OX - Configure To Order (Factory Installed) or Field Installed

O = Configure To Order (Factory Installed)

X = Field Installed

OPTIONS / ACCESSORIES

Item Description	Model Number	Catalog Number	Unit Model No			
			092	102	120	150
INDOOR AIR QUALITY						
Air Filters						
Healthy Climate® High Efficiency Air Filters	MERV 8 - C1FLTR15B-1	50W61	X	X	X	X
20 x 25 x 2 (Order 4 per unit)	MERV 13 - C1FLTR40B-1	52W41	X	X	X	X
Replacement Media Filter With Metal Mesh Frame (includes non-pleated filter media)	C1FLTR30B-1-	Y3063	X	X	X	X
Indoor Air Quality (CO₂) Sensors						
Sensor - Wall-mount, off-white plastic cover with LCD display	C0SNSR50AE1L	77N39	X	X	X	X
Sensor - Wall-mount, off-white plastic cover, no display	C0SNSR52AE1L	87N53	X	X	X	X
Sensor - Black plastic case with LCD display, rated for plenum mounting	C0SNSR51AE1L	87N52	X	X	X	X
Sensor - Wall-mount, black plastic case, no display, rated for plenum mounting	C0MISC19AE1	87N54	X	X	X	X
CO ₂ Sensor Duct Mounting Kit - for downflow applications	C0MISC19AE1-	85L43	X	X	X	X
Aspiration Box - for duct mounting non-plenum rated CO ₂ sensors (87N53 or 77N39)	C0MISC16AE1-	90N43	X	X	X	X
UVC Germicidal Lamps						
¹ Healthy Climate® UVC Light Kit (208/230v-1ph)	C1UVCL10B-1	54W62	X	X	X	X
HUMIDITROL® DEHUMIDIFICATION CONDENSER REHEAT OPTION						
Humiditrol® Dehumidification Option		Factory	O	O	O	O
² Dehumidistat, Remote Mounted	C0SNSR30FF1L	99N41	X	X	X	X
ELECTRICAL						
Voltage 60 hz	208/230V - 3 phase	Factory	O	O	O	O
	460V - 3 phase	Factory	O	O	O	O
	575V - 3 phase	Factory	O	O	O	O
Disconnect Switch - See Electrical/Electric Heat tables for selection	80 amp - C1DISC080B-1	54W56	OX	OX	OX	OX
	150 amp - C1DISC150B-1	54W57	OX	OX	OX	OX
GFI Service Outlets 15 amp non-powered, field-wired (208/230V, 460V only)	LTAGFIK10/15	74M70	OX	OX	OX	OX
	20 amp non-powered, field-wired (575V only)	C1GFCI20FF1	67E01	X	X	X
Weatherproof Cover for GFI	C1GFCI99FF1	10C89	X	X	X	X
³ ELECTRIC HEAT						
7.5 kW	208/230V-3ph - C1EH0075B-1Y	56W38	OX	OX		
	460V-3ph - C1EH0075B-1G	56W39	OX	OX		
	575V-3ph - C1EH0075B-1J	56W40	OX	OX		
15 kW	208/230V-3ph - C1EH0150B-1Y	56W41	OX	OX	OX	OX
	460V-3ph - C1EH0150B-1G	56W42	OX	OX	OX	OX
	575V-3ph - C1EH0150B-1J	56W43	OX	OX	OX	OX
22.5 kW	208/230V-3ph - C1EH0225B-1Y	56W44	OX	OX	OX	OX
	460V-3ph - C1EH0225B-1G	56W45	OX	OX	OX	OX
	575V-3ph - C1EH0225B-1J	56W46	OX	OX	OX	OX
30 kW	208/230V-3ph - C1EH0300B-1Y	56W47	OX	OX	OX	OX
	460V-3ph - C1EH0300B-1G	56W48	OX	OX	OX	OX
	575V-3ph - C1EH0300B-1J	56W49	OX	OX	OX	OX
45 kW	208/230V-3ph - C1EH0450B-1Y	56W50	OX	OX	OX	OX
	460V-3ph - C1EH0450B-1G	56W51	OX	OX	OX	OX
	575V-3ph - C1EH0450B-1J	56W52	OX	OX	OX	OX
60 kW	208/230V-3ph - C1EH0600B-1Y	55W02			OX	OX
	460V-3ph - C1EH0600B-1G	55W03			OX	OX
	575V-3ph - C1EH0600B-1J	55W04			OX	OX

¹ Lamps operate on 110-230V single-phase power supply. Step-down transformer may be ordered separately for 460V and 575V units. Alternately, 110V power supply may be used to directly power the UVC ballast(s).

² A thermostat with a dehumidification output or a DDC controller with an isolated output can be used instead.

³ NOTE - Factory installed electric heat is only available with high efficiency models.

NOTE - Catalog and model numbers shown are for ordering field installed accessories.

OX - Configure To Order (Factory Installed) or Field Installed

O = Configure To Order (Factory Installed)

X = Field Installed

OPTIONS / ACCESSORIES

Item Description	Model Number	Catalog Number	Unit Model No			
			092	102	120	150
ECONOMIZER						
Standard Economizer (Not for Title 24)						
Standard Economizer with Single Temperature Control Downflow or Horizontal Applications - Includes Barometric Relief Dampers and Air Hoods	K1ECON20B-2	13U45	OX	OX	OX	OX
Standard Economizer Controls (Not for Title 24)						
Single Enthalpy Control	C1SNSR64FF1	53W64	OX	OX	OX	OX
Differential Enthalpy Control (order 2)	C1SNSR64FF1	53W64	X	X	X	X
High Performance Economizer (Approved for California Title 24 Building Standards / AMCA Class 1A Certified)						
High Performance Economizer with Single Temperature Control Downflow or Horizontal Applications - Includes Barometric Relief Dampers and Air Hoods	K1ECON22B-3	17U09	OX	OX	OX	OX
High Performance Economizer Controls (Not for Title 24)						
Single Enthalpy Control	C1SNSR60FF1	10Z75	OX	OX	OX	OX
Differential Enthalpy Control (order 2)	C1SNSR60FF1	10Z75	X	X	X	X
Horizontal Low Profile Barometric Relief Dampers With Exhaust Hood						
Horizontal Low Profile Barometric Relief Dampers With Exhaust Hood	LAGEDH03/15	53K04	X	X	X	X
OUTDOOR AIR						
Outdoor Air Dampers With Outdoor Air Hood						
Motorized	C1DAMP20B-1	14G28	OX	OX	OX	OX
Manual	C1DAMP10B-1	14G29	OX	OX	OX	OX
POWER EXHAUST						
Standard Static	208/230V-3ph - K1PWRE10B-1Y	53W44	X	X	X	X
	460V-3ph - K1PWRE10B-1G	53W45	X	X	X	X
	575V-3ph - K1PWRE10B-1J	53W46	X	X	X	X
ROOF CURBS						
Hybrid Roof Curbs, Downflow						
8 in. height	C1CURB70B-1	11F54	X	X	X	X
14 in. height	C1CURB71B-1	11F55	X	X	X	X
18 in. height	C1CURB72B-1	11F56	X	X	X	X
24 in. height	C1CURB73B-1	11F57	X	X	X	X
Adjustable Pitch Curb						
14 in. height	C1CURB55B-1	54W50	X	X	X	X
CEILING DIFFUSERS						
Step-Down - Order one	RTD11-95S	13K61	X			
	RTD11-135S	13K62		X	X	
	RTD11-185S	13K63				X
Flush - Order one	FD11-95S	13K56	X			
	FD11-135S	13K57		X	X	
	FD11-185S	13K58				X
Transitions (Supply and Return) - Order one	C1DIFF30B-1	12X65	X			
	C1DIFF31B-1	12X66		X	X	
	C1DIFF32B-1	12X67				X

NOTE - Catalog and model numbers shown are for ordering field installed accessories.

OX - Configure To Order (Factory Installed) or Field Installed

O = Configure To Order (Factory Installed)

X = Field Installed

SPECIFICATIONS			7.5 TON			
General Data		Nominal Tonnage	7.5 Ton	7.5 Ton	7.5 Ton	7.5 Ton
		Model Number	KCB092S4B	KCB092S4M	KCA092H4B	KCA092H4M
		Efficiency Type	Standard	Standard	High	High
		Blower Type	CAV (Constant Air Volume)	MSAV® (Multi-Stage Air Volume)	CAV (Constant Air Volume)	MSAV® (Multi-Stage Air Volume)
Cooling Performance	Gross Cooling Capacity - Btuh		87,800	87,800	93,000	93,000
	¹ Net Cooling Capacity - Btuh		86,000	86,000	90,000	90,000
	AHRI Rated Air Flow - cfm		2400	2400	3000	2800
	Total Unit Power - kW		7.7	7.7	7.1	7.1
	¹ EER (Btuh/Watt)		11.2	11.2	12.7	12.7
	¹ IEER (Btuh/Watt)		12.9	13.6	13.0	14.0
AHRI Reference Number			10609475	202088990	202089011	202075431
Refrigerant Charge	Refrigerant Type		R-410A	R-410A	R-410A	R-410A
	Environ™ Coil System	Circuit 1	4 lbs. 0 oz.	4 lbs. 0 oz.	6 lbs. 13 oz.	6 lbs. 13 oz.
		Circuit 2	3 lbs. 6 oz.	3 lbs. 6 oz.	7 lbs. 2 oz.	7 lbs. 2 oz.
	Conventional Fin/Tube Coil Option	Circuit 1	9 lbs. 0 oz.	9 lbs. 0 oz.	---	---
		Circuit 2	6 lbs. 13 oz.	6 lbs. 13 oz.	---	---
	Conventional Fin/Tube with Humiditrol® Option	Circuit 1	10 lbs. 4 oz.	10 lbs. 4 oz.	---	---
		Circuit 2	7 lbs. 0 oz.	7 lbs. 0 oz.	---	---
Electric Heat Available - See page 11			7.5, 15, 22.5, 30 & 45 KW			
Compressor Type (number)			Scroll (2)	Scroll (2)	Scroll (2)	Scroll (2)
Outdoor Coils	Net face area (total) - sq. ft.		20.5	20.5	28.0	28.0
	Environ (Fin/Tube)	Number of rows	1 (2)	1 (2)	1	1
Fins per inch		23 (20)	23 (20)	20	20	
Outdoor Coil Fans	Motor - (No.) hp		(2) 1/3	(2) 1/3	(2) 1/3	(2) 1/3
	Motor rpm		1075	1075	1075	1075
	Total Motor watts		740	740	800	800
	Diameter - (No.) in.		(2) 24	(2) 24	(2) 24	(2) 24
	Number of blades		3	3	3	3
	Total Air volume - cfm		8800	8800	8800	8800
	Indoor Coils	Net face area (total) - sq. ft.		12.78	12.78	12.78
Tube diameter - in.		3/8	3/8	3/8	3/8	
Number of rows		2	2	4	4	
Fins per inch		14	14	14	14	
Drain connection - Number and size		(1) 1 in. NPT coupling				
Expansion device type		Refrigerant Metering Orifice (RFC) - No Humiditrol® Option		Balanced port TXV, removable head		
		Balanced port TXV, removable head - Humiditrol® Option				
² Indoor Blower and Drive Selection	Nominal motor output		2 hp, 3 hp, 5 hp			
	Maximum usable motor output (US Only)		2.3 hp, 3.45 hp, 5.75 hp			
	Motor - Drive kit number		2 hp			
			Kit 1 590-890 rpm Kit 2 800-1105 rpm Kit 3 795-1195 rpm			
		3 hp				
		Kit 7 730-970 rpm Kit 8 940-1200 rpm Kit 9 1015-1300 rpm				
		5 hp				
		Kit 10 900-1135 rpm Kit 11 1040-1315 rpm Kit 12 1125-1425 rpm				
Blower wheel nominal diameter x width - in.			(1) 15 X 15	(1) 15 X 15	(1) 15 X 15	(1) 15 X 15
Filters	Type of filter		Disposable			
	Number and size - in.		(4) 20 x 25 x 2			
Electrical characteristics			208/230V, 460V or 575V - 60 hertz - 3 phase			

NOTE - Net capacity includes evaporator blower motor heat deduction. Gross capacity does not include evaporator blower motor heat deduction.

¹ AHRI Certified to AHRI Standard 340/360; 95°F outdoor air temperature and 80°F db/67°F wb entering evaporator air; minimum external duct static pressure.

² Using total air volume and system static pressure requirements determine from blower performance tables rpm and motor output required. Maximum usable output of motors furnished are shown. In Canada, nominal motor output is also maximum usable motor output. If motors of comparable output are used, be sure to keep within the service factor limitations outlined on the motor nameplate.

NOTE - Units equipped with MSAV® (Multi-Stage Air Volume) option are limited to a motor service factor of 1.0.

SPECIFICATIONS **8.5 TON**

General Data		Nominal Tonnage	8.5 Ton	8.5 Ton	8.5 Ton	8.5 Ton
Model Number			KCB102S4B	KCB102S4M	KCA102H4B	KCA102H4M
Efficiency Type			Standard	Standard	High	High
Blower Type			CAV (Constant Air Volume)	MSAV® (Multi-Stage Air Volume)	CAV (Constant Air Volume)	MSAV® (Multi-Stage Air Volume)
Cooling Performance	Gross Cooling Capacity - Btuh		99,600	99,600	103,800	103,800
	¹ Net Cooling Capacity - Btuh		97,000	97,000	100,000	100,000
	AHRI Rated Air Flow - cfm		2800	2800	3400	3400
	Total Unit Power - kW		8.7	8.7	8.1	8.1
	¹ EER (Btuh/Watt)		11.2	11.2	12.4	12.4
	¹ IEER (Btuh/Watt)		12.9	13.8	12.9	14.0
AHRI Reference Number			10609473	202088979	202089012	202090509
Refrigerant Charge		Refrigerant Type	R-410A	R-410A	R-410A	R-410A
	Environ™ Coil System	Circuit 1	4 lbs. 5 oz.	4 lbs. 5 oz.	6 lbs. 8 oz.	6 lbs. 8 oz.
		Circuit 2	4 lbs. 3 oz.	4 lbs. 3 oz.	6 lbs. 15 oz.	6 lbs. 15 oz.
	Conventional Fin/Tube Coil Option	Circuit 1	9 lbs. 3 oz.	9 lbs. 3 oz.	---	---
		Circuit 2	7 lbs. 14 oz.	7 lbs. 14 oz.	---	---
	Conventional Fin/Tube with Humiditrol® Option	Circuit 1	9 lbs. 8 oz.	9 lbs. 8 oz.	---	---
		Circuit 2	9 lbs. 4 oz.	9 lbs. 4 oz.	---	---
Electric Heat Available - See page 11			7.5, 15, 22.5, 30 & 45 KW			
Compressor Type (number)			Scroll (2)	Scroll (2)	Scroll (2)	Scroll (2)
Outdoor Coils	Net face area (total) - sq. ft.		20.5	20.5	28.0	28.0
	Number of rows		1 (2)	1 (2)	1	1
Outdoor Coils (Fin/Tube)	Fins per inch		23 (20)	23 (20)	20	20
Outdoor Coil Fans	Motor - (No.) hp		(2) 1/3	(2) 1/3	(2) 1/3	(2) 1/3
	Motor rpm		1075	1075	1075	1075
	Total Motor watts		740	740	800	800
	Diameter - (No.) in.		(2) 24	(2) 24	(2) 24	(2) 24
	Number of blades		3	3	3	3
	Total Air volume - cfm		8800	8800	8800	8800
Indoor Coils	Net face area (total) - sq. ft.		12.78	12.78	12.78	12.78
	Tube diameter - in.		3/8	3/8	3/8	3/8
	Number of rows		3	3	4	4
	Fins per inch		14	14	14	14
	Drain connection - Number and size		(1) 1 in. NPT coupling			
Expansion device type			Refrigerant Metering Orifice (RFC) - No Humiditrol® Option Balanced port TXV, removable head - Humiditrol® Option		Balance port TXV, removable head	
² Indoor Blower and Drive Selection	Nominal motor output		2 hp, 3 hp, 5 hp			
	Maximum usable motor output (US Only)		2.3 hp, 3.45 hp, 5.75 hp			
	Motor - Drive kit number		2 hp Kit 1 590-890 rpm Kit 2 800-1105 rpm Kit 3 795-1195 rpm			
			3 hp Kit 7 730-970 rpm Kit 8 940-1200 rpm Kit 9 1015-1300 rpm			
		5 hp Kit 10 900-1135 rpm Kit 11 1040-1315 rpm Kit 12 1125-1425 rpm				
Blower wheel nominal diameter x width - in.			(1) 15 X 15	(1) 15 X 15	(1) 15 X 15	(1) 15 X 15
Filters	Type of filter		Disposable			
	Number and size - in.		(4) 20 x 25 x 2			
Electrical characteristics			208/230V, 460V or 575V - 60 hertz - 3 phase			

NOTE - Net capacity includes evaporator blower motor heat deduction. Gross capacity does not include evaporator blower motor heat deduction.
¹ AHRI Certified to AHRI Standard 340/360; 95°F outdoor air temperature and 80°F db/67°F wb entering evaporator air; minimum external duct static pressure.
² Using total air volume and system static pressure requirements determine from blower performance tables rpm and motor output required. Maximum usable output of motors furnished are shown. In Canada, nominal motor output is also maximum usable motor output. If motors of comparable output are used, be sure to keep within the service factor limitations outlined on the motor nameplate.
 NOTE - Units equipped with MSAV® (Multi-Stage Air Volume) option are limited to a motor service factor of 1.0.

SPECIFICATIONS			10 TON			
General Data		Nominal Tonnage	10 Ton	10 Ton	10 Ton	10 Ton
		Model Number	KCB120S4B	KCB120S4M	KCA120H4B	KCA120H4M
		Efficiency Type	Standard	Standard	High	High
		Blower Type	CAV (Constant Air Volume)	MSAV® (Multi-Stage Air Volume)	CAV (Constant Air Volume)	MSAV® (Multi-Stage Air Volume)
Cooling Performance	Gross Cooling Capacity - Btuh		118,000	118,000	122,000	122,000
	¹ Net Cooling Capacity - Btuh		115,000	115,000	118,000	118,000
	AHRI Rated Air Flow - cfm		3000	3000	3600	3300
	Total Unit Power - kW		10.3	10.3	9.7	9.7
	¹ EER (Btuh/Watt)		11.2	11.2	12.2	12.2
	¹ IEER (Btuh/Watt)		12.9	13.6	13.2	14.0
AHRI Reference Number			10609471	202088980	202088949	202090475
Refrigerant Charge	Refrigerant Type		R-410A	R-410A	R-410A	R-410A
	Environ™ Coil System	Circuit 1	5 lbs. 7 oz.	5 lbs. 7 oz.	7 lbs. 4 oz.	7 lbs. 4 oz.
		Circuit 2	5 lbs. 12 oz.	5 lbs. 12 oz.	7 lbs. 8 oz.	7 lbs. 8 oz.
	Conventional Fin/Tube Coil Option	Circuit 1	9 lbs. 15 oz.	9 lbs. 15 oz.	---	---
		Circuit 2	9 lbs. 1 oz.	9 lbs. 1 oz.	---	---
	Conventional Fin/Tube with Humiditrol® Option	Circuit 1	10 lbs. 8 oz.	10 lbs. 8 oz.	---	---
		Circuit 2	8 lbs. 0 oz.	8 lbs. 0 oz.	---	---
Electric Heat Available - See page 11			15, 22.5, 30, 45 & 60 KW			
Compressor Type (number)			Scroll (2)	Scroll (2)	Scroll (2)	Scroll (2)
Outdoor Coils	Net face area (total) - sq. ft.		28.0	28.0	28.0	28.0
Environ (Fin/Tube)	Number of rows		1(2)	1 (2)	1	1
	Fins per inch		23 (20)	23 (20)	20	20
Outdoor Coil Fans	Motor - (No.) hp		(2) 1/3	(2) 1/3	(2) 1/3	(2) 1/3
	Motor rpm		1075	1075	1075	1075
	Total Motor watts		690	690	800	800
	Diameter - (No.) in.		(2) 24	(2) 24	(2) 24	(2) 24
	Number of blades		3	3	3	3
	Total Air volume - cfm		9300	9300	8800	8800
Indoor Coils	Net face area (total) - sq. ft.		12.78	12.78	13.54	13.54
	Tube diameter - in.		3/8	3/8	3/8	3/8
	Number of rows		4	4	4	4
	Fins per inch		14	14	14	14
Drain connection - Number and size			(1) 1 in. NPT coupling			
Expansion device type			Refrigerant Metering Orifice (RFC) - No Humiditrol® Option Balanced port TXV, removable head - Humiditrol® Option		Balance port TXV, removable head	
² Indoor Blower and Drive Selection	Nominal motor output		2 hp, 3 hp, 5 hp			
	Maximum usable motor output (US Only)		2.3 hp, 3.45 hp, 5.75 hp			
	Motor - Drive kit number		2 hp Kit 1 590-890 rpm Kit 2 800-1105 rpm Kit 3 795-1195 rpm			
			3 hp Kit 7 730-970 rpm Kit 8 940-1200 rpm Kit 9 1015-1300 rpm			
		5 hp Kit 10 900-1135 rpm Kit 11 1040-1315 rpm Kit 12 1125-1425 rpm				
Blower wheel nominal diameter x width - in.			(1) 15 X 15	(1) 15 X 15	(1) 15 X 15	(1) 15 X 15
Filters	Type of filter		Disposable			
	Number and size - in.		(4) 20 x 25 x 2			
Electrical characteristics			208/230V, 460V or 575V - 60 hertz - 3 phase			

NOTE - Net capacity includes evaporator blower motor heat deduction. Gross capacity does not include evaporator blower motor heat deduction.

¹ AHRI Certified to AHRI Standard 340/360; 95°F outdoor air temperature and 80°F db/67°F wb entering evaporator air; minimum external duct static pressure.

² Using total air volume and system static pressure requirements determine from blower performance tables rpm and motor output required. Maximum usable output of motors furnished are shown. In Canada, nominal motor output is also maximum usable motor output. If motors of comparable output are used, be sure to keep within the service factor limitations outlined on the motor nameplate.

NOTE – Units equipped with MSAV® (Multi-Stage Air Volume) option are limited to a motor service factor of 1.0.

SPECIFICATIONS			12.5 TON	
General Data		Nominal Tonnage	12.5 Ton	12.5 Ton
		Model Number	KCB150S4B	KCB150S4M
		Efficiency Type	Standard	Standard
		Blower Type	CAV (Constant Air Volume)	MSAV® (Multi-Stage Air Volume)
Cooling Performance	Gross Cooling Capacity - Btuh		148,000	148,000
	¹ Net Cooling Capacity - Btuh		142,000	142,000
	AHRI Rated Air Flow - cfm		3950	3950
	Total Unit Power - kW		12.9	12.9
	¹ EER (Btuh/Watt)		11.0	11.0
	¹ IEER (Btuh/Watt)		12.4	13.5
AHRI Reference Number			10609467	10609469
Refrigerant Charge	Refrigerant Type		R-410A	R-410A
	Fin/Tube Coil	Circuit 1	12 lbs. 8 oz.	12 lbs. 8 oz.
		Circuit 2	10 lbs. 12 oz.	10 lbs. 12 oz.
	Fin/Tube Coil with Humiditrol® Option	Circuit 1	12 lbs. 9 oz.	12 lbs. 9 oz.
		Circuit 2	10 lbs. 12 oz.	10 lbs. 12 oz.
Electric Heat Available - See page 11			15, 22.5, 30, 45 & 60 KW	
Compressor Type (number)			Scroll (2)	Scroll (2)
Outdoor Coils	Net face area (total) - sq. ft.		25.9	25.9
	Number of rows		3	3
	Fins per inch		20	20
Outdoor Coil Fans	Motor - (No.) hp		(2) 1/2	(2) 1/2
	Motor rpm		1075	1075
	Total Motor watts		1050	1050
	Diameter - (No.) in.		(2) 24	(2) 24
	Number of blades		3	3
	Total Air volume - cfm		9700	9700
	Indoor Coils	Net face area (total) - sq. ft.		13.54
Tube diameter - in.		3/8	3/8	
Number of rows		4	4	
Fins per inch		14	14	
Drain connection - Number and size		(1) 1 in. NPT coupling		
Expansion device type		Balance port TXV, removable head		
² Indoor Blower and Drive Selection	Nominal motor output		2 hp, 3 hp, 5 hp	
	Maximum usable motor output (US Only)		2.3 hp, 3.45 hp, 5.75 hp	
	Motor - Drive kit number		2 hp Kit 1 590-890 rpm Kit 2 800-1105 rpm Kit 3 795-1195 rpm 3 hp Kit 7 730-970 rpm Kit 8 940-1200 rpm Kit 9 1015-1300 rpm 5 hp Kit 10 900-1135 rpm Kit 11 1040-1315 rpm Kit 12 1125-1425 rpm	
	Blower wheel nominal diameter x width - in.		(1) 15 X 15	(1) 15 X 15
Filters	Type of filter		Disposable	
	Number and size - in.		(4) 20 x 25 x 2	
Electrical characteristics		208/230V, 460V or 575V - 60 hertz - 3 phase		

NOTE - Net capacity includes evaporator blower motor heat deduction. Gross capacity does not include evaporator blower motor heat deduction.

¹ AHRI Certified to AHRI Standard 340/360; 95°F outdoor air temperature and 80°F db/67°F wb entering evaporator air; minimum external duct static pressure.

² Using total air volume and system static pressure requirements determine from blower performance tables rpm and motor output required. Maximum usable output of motors furnished are shown. In Canada, nominal motor output is also maximum usable motor output. If motors of comparable output are used, be sure to keep within the service factor limitations outlined on the motor nameplate.

NOTE – Units equipped with MSAV® (Multi-Stage Air Volume) option are limited to a motor service factor of 1.0.

RATINGS

NOTE – For Temperatures and Capacities not shown in tables, see bulletin – Cooling Unit Rating Table Correction Factor Data in Miscellaneous Engineering Data section.

12.5 TON STANDARD EFFICIENCY KCB150S4B (1ST STAGE) - CONSTANT AIR VOLUME

Entering Wet Bulb Temperature	Total Air Volume	Outdoor Air Temperature Entering Outdoor Coil																			
		65°F					75°F					85°F					95°F				
		Total Cool Cap.	Comp. Motor Input	Sensible To Total Ratio (S/T)			Total Cool Cap.	Comp. Motor Input	Sensible To Total Ratio (S/T)			Total Cool Cap.	Comp. Motor Input	Sensible To Total Ratio (S/T)			Total Cool Cap.	Comp. Motor Input	Sensible To Total Ratio (S/T)		
				Dry Bulb					Dry Bulb					Dry Bulb					Dry Bulb		
		cfm	kBtuh	kW	75°F	80°F	85°F	kBtuh	kW	75°F	80°F	85°F	kBtuh	kW	75°F	80°F	85°F	kBtuh	kW	75°F	80°F
63°F	3800	76.4	3.46	0.67	0.81	0.96	72	3.83	0.67	0.82	0.98	67	4.24	0.68	0.84	0.99	61.7	4.69	0.68	0.86	1
	4400	79.6	3.47	0.71	0.86	1	74.9	3.84	0.71	0.88	1	69.9	4.25	0.71	0.9	1	64.4	4.7	0.73	0.92	1
	5000	82.3	3.49	0.74	0.91	1	77.5	3.85	0.74	0.93	1	72.2	4.26	0.76	0.95	1	66.6	4.71	0.77	0.98	1
67°F	3800	81.9	3.48	0.53	0.65	0.78	77.2	3.85	0.53	0.65	0.79	72.3	4.26	0.52	0.66	0.8	66.8	4.71	0.52	0.66	0.82
	4400	85.2	3.5	0.55	0.68	0.82	80.4	3.86	0.55	0.69	0.84	75.1	4.27	0.54	0.69	0.85	69.6	4.72	0.54	0.7	0.88
	5000	87.8	3.51	0.57	0.71	0.87	82.8	3.88	0.57	0.72	0.89	77.6	4.28	0.57	0.73	0.91	71.8	4.73	0.56	0.74	0.94
71°F	3800	87.7	3.51	0.41	0.52	0.63	83	3.87	0.4	0.52	0.63	77.8	4.28	0.38	0.52	0.64	72.3	4.73	0.37	0.51	0.64
	4400	90.7	3.52	0.42	0.54	0.66	85.8	3.89	0.41	0.54	0.66	80.6	4.29	0.4	0.54	0.67	74.8	4.74	0.38	0.53	0.68
	5000	93.6	3.54	0.43	0.56	0.69	88.3	3.9	0.41	0.56	0.7	82.9	4.3	0.41	0.56	0.71	77	4.75	0.4	0.56	0.72

12.5 TON STANDARD EFFICIENCY KCB150S4B (2ND STAGE) - CONSTANT AIR VOLUME

Entering Wet Bulb Temperature	Total Air Volume	Outdoor Air Temperature Entering Outdoor Coil																			
		85°F					95°F					105°F					115°F				
		Total Cool Cap.	Comp. Motor Input	Sensible To Total Ratio (S/T)			Total Cool Cap.	Comp. Motor Input	Sensible To Total Ratio (S/T)			Total Cool Cap.	Comp. Motor Input	Sensible To Total Ratio (S/T)			Total Cool Cap.	Comp. Motor Input	Sensible To Total Ratio (S/T)		
				Dry Bulb					Dry Bulb					Dry Bulb					Dry Bulb		
		cfm	kBtuh	kW	75°F	80°F	85°F	kBtuh	kW	75°F	80°F	85°F	kBtuh	kW	75°F	80°F	85°F	kBtuh	kW	75°F	80°F
63°F	3800	146.9	9.2	0.69	0.84	0.98	135.7	10.21	0.7	0.86	1	124.2	11.34	0.7	0.88	1	111.9	12.62	0.72	0.91	1
	4400	153	9.23	0.73	0.89	1	141.3	10.23	0.74	0.91	1	129.5	11.37	0.75	0.94	1	117	12.65	0.77	0.98	1
	5000	158	9.26	0.76	0.94	1	146.2	10.27	0.77	0.97	1	134.2	11.4	0.8	0.99	1	121.8	12.67	0.82	1	1
67°F	3800	157.9	9.26	0.54	0.67	0.81	146.4	10.26	0.53	0.68	0.82	134.6	11.39	0.52	0.68	0.84	122.2	12.68	0.51	0.69	0.87
	4400	164.1	9.29	0.56	0.71	0.86	152.4	10.3	0.56	0.72	0.88	139.9	11.43	0.55	0.73	0.9	127.1	12.7	0.55	0.75	0.94
	5000	169.2	9.32	0.58	0.74	0.91	157.1	10.33	0.58	0.75	0.93	144.6	11.47	0.58	0.77	0.96	131.1	12.73	0.59	0.79	0.99
71°F	3800	169.9	9.32	0.39	0.53	0.65	158	10.34	0.38	0.52	0.65	145.8	11.47	0.37	0.52	0.66	132.7	12.74	0.35	0.51	0.67
	4400	176	9.36	0.41	0.55	0.69	163.6	10.36	0.4	0.55	0.7	151.1	11.51	0.38	0.54	0.71	137.4	12.77	0.37	0.54	0.72
	5000	180.9	9.39	0.42	0.57	0.72	168.2	10.39	0.41	0.57	0.73	155.3	11.52	0.4	0.57	0.75	141.4	12.79	0.39	0.58	0.77

RATINGS

NOTE – For Temperatures and Capacities not shown in tables, see bulletin – Cooling Unit Rating Table Correction Factor Data in Miscellaneous Engineering Data section.

12.5 TON STANDARD EFFICIENCY KCB150S4M (1ST STAGE) - MSAV® (Multi-Stage Air Volume) SUPPLY AIR BLOWER

Entering Wet Bulb Temperature	Total Air Volume	Outdoor Air Temperature Entering Outdoor Coil																							
		65°F						75°F						85°F						95°F					
		Total Cool Cap.	Comp. Motor Input	Sensible To Total Ratio (S/T)			Total Cool Cap.	Comp. Motor Input	Sensible To Total Ratio (S/T)			Total Cool Cap.	Comp. Motor Input	Sensible To Total Ratio (S/T)			Total Cool Cap.	Comp. Motor Input	Sensible To Total Ratio (S/T)						
				Dry Bulb					Dry Bulb					Dry Bulb					Dry Bulb						
				75°F	80°F	85°F			75°F	80°F	85°F			75°F	80°F	85°F			75°F	80°F	85°F	75°F	80°F	85°F	
cfm	kBtuh	kW	75°F	80°F	85°F	kBtuh	kW	75°F	80°F	85°F	kBtuh	kW	75°F	80°F	85°F	kBtuh	kW	75°F	80°F	85°F					
63°F	2560	68.8	3.41	0.64	0.74	0.84	64.5	3.8	0.63	0.74	0.85	60	4.21	0.62	0.74	0.86	55.3	4.66	0.62	0.75	0.88				
	3200	74.6	3.44	0.67	0.79	0.91	70.1	3.82	0.67	0.8	0.92	65.2	4.22	0.67	0.8	0.94	60.3	4.68	0.67	0.82	0.96				
	3480	76.6	3.45	0.69	0.81	0.93	72	3.82	0.69	0.82	0.95	67.2	4.23	0.69	0.83	0.97	61.9	4.68	0.69	0.84	0.99				
67°F	2560	74.2	3.44	0.51	0.62	0.71	69.9	3.82	0.5	0.61	0.71	65.4	4.23	0.49	0.6	0.71	60.6	4.69	0.48	0.6	0.72				
	3200	80	3.46	0.54	0.65	0.76	75.3	3.84	0.53	0.64	0.76	70.6	4.25	0.52	0.65	0.77	65.3	4.7	0.51	0.65	0.78				
	3480	82.1	3.47	0.55	0.67	0.78	77.5	3.84	0.54	0.66	0.78	72.5	4.25	0.53	0.66	0.8	67.1	4.7	0.52	0.67	0.81				
71°F	2560	79.9	3.46	0.41	0.5	0.59	75.6	3.84	0.39	0.49	0.58	70.8	4.24	0.37	0.48	0.58	65.9	4.7	0.35	0.47	0.58				
	3200	86	3.49	0.42	0.52	0.63	81.4	3.86	0.4	0.52	0.62	76.5	4.27	0.39	0.51	0.63	71.1	4.72	0.37	0.5	0.62				
	3480	88.2	3.5	0.42	0.53	0.64	83.4	3.87	0.41	0.53	0.64	78.3	4.27	0.4	0.52	0.64	72.9	4.73	0.38	0.52	0.64				

12.5 TON STANDARD EFFICIENCY KCB150S4M (2ND STAGE) - MSAV® (Multi-Stage Air Volume) SUPPLY AIR BLOWER

Entering Wet Bulb Temperature	Total Air Volume	Outdoor Air Temperature Entering Outdoor Coil																							
		85°F						95°F						105°F						115°F					
		Total Cool Cap.	Comp. Motor Input	Sensible To Total Ratio (S/T)			Total Cool Cap.	Comp. Motor Input	Sensible To Total Ratio (S/T)			Total Cool Cap.	Comp. Motor Input	Sensible To Total Ratio (S/T)			Total Cool Cap.	Comp. Motor Input	Sensible To Total Ratio (S/T)						
				Dry Bulb					Dry Bulb					Dry Bulb					Dry Bulb						
				75°F	80°F	85°F			75°F	80°F	85°F			75°F	80°F	85°F			75°F	80°F	85°F	75°F	80°F	85°F	
cfm	kBtuh	kW	75°F	80°F	85°F	kBtuh	kW	75°F	80°F	85°F	kBtuh	kW	75°F	80°F	85°F	kBtuh	kW	75°F	80°F	85°F					
63°F	3800	146.9	9.2	0.69	0.84	0.98	135.7	10.21	0.7	0.86	1	124.2	11.34	0.7	0.88	1	111.9	12.62	0.72	0.91	1				
	4400	153	9.23	0.73	0.89	1	141.3	10.23	0.74	0.91	1	129.5	11.37	0.75	0.94	1	117	12.65	0.77	0.98	1				
	5000	158	9.26	0.76	0.94	1	146.2	10.27	0.77	0.97	1	134.2	11.4	0.8	0.99	1	121.8	12.67	0.82	1	1				
67°F	3800	157.9	9.26	0.54	0.67	0.81	146.4	10.26	0.53	0.68	0.82	134.6	11.39	0.52	0.68	0.84	122.2	12.68	0.51	0.69	0.87				
	4400	164.1	9.29	0.56	0.71	0.86	152.4	10.3	0.56	0.72	0.88	139.9	11.43	0.55	0.73	0.9	127.1	12.7	0.55	0.75	0.94				
	5000	169.2	9.32	0.58	0.74	0.91	157.1	10.33	0.58	0.75	0.93	144.6	11.47	0.58	0.77	0.96	131.1	12.73	0.59	0.79	0.99				
71°F	3800	169.9	9.32	0.39	0.53	0.65	158	10.34	0.38	0.52	0.65	145.8	11.47	0.37	0.52	0.66	132.7	12.74	0.35	0.51	0.67				
	4400	176	9.36	0.41	0.55	0.69	163.6	10.36	0.4	0.55	0.7	151.1	11.51	0.38	0.54	0.71	137.4	12.77	0.37	0.54	0.72				
	5000	180.9	9.39	0.42	0.57	0.72	168.2	10.39	0.41	0.57	0.73	155.3	11.52	0.4	0.57	0.75	141.4	12.79	0.39	0.58	0.77				

HUMIDITROL® DEHUMIDIFICATION SYSTEM RATINGS

NOTE - For Temperatures and Capacities not shown in tables, see bulletin - Cooling Unit Rating Table Correction Factor Data in Miscellaneous Engineering Data section.

7.5 TON STANDARD EFFICIENCY WITH KCB092S4 HUMIDITROL® OPERATING (1ST STAGE)

Entering Wet Bulb Temperature	Total Air Volume	Outdoor Air Temperature Entering Outdoor Coil																			
		65°F						75°F					85°F					95°F			
		Total Cool Cap.	Comp. Motor Input	Sensible To Total Ratio (S/T)			Total Cool Cap.	Comp. Motor Input	Sensible To Total Ratio (S/T)			Total Cool Cap.	Comp. Motor Input	Sensible To Total Ratio (S/T)			Total Cool Cap.	Comp. Motor Input	Sensible To Total Ratio (S/T)		
				Dry Bulb					Dry Bulb					Dry Bulb					Dry Bulb		
cfm	kBtuh	kW	75°F	80°F	85°F	kBtuh	kW	75°F	80°F	85°F	kBtuh	kW	75°F	80°F	85°F	kBtuh	kW	75°F	80°F	85°F	
63°F	2400	38.7	3.9	0.48	0.63	0.78	30.9	3.8	0.34	0.57	0.79	23.1	3.8	0.20	0.50	0.80	15.3	3.7	0.06	0.43	0.80
	3000	40.8	3.3	0.53	0.71	0.88	31.7	3.4	0.37	0.68	0.89	22.7	3.6	0.22	0.64	0.90	13.6	3.8	0.06	0.61	0.90
	3600	42.9	2.6	0.58	0.78	0.98	32.6	3.0	0.40	0.78	0.98	22.3	3.3	0.23	0.79	0.99	12.0	3.6	0.05	0.79	1.00
67°F	2400	44.3	3.3	0.34	0.48	0.62	36.3	3.1	0.20	0.39	0.58	28.3	2.9	0.05	0.30	0.55	20.3	2.7	-0.10	0.21	0.51
	3000	46.5	3.0	0.37	0.60	0.69	37.3	2.9	0.20	0.50	0.65	28.0	2.8	0.02	0.39	0.62	18.8	2.7	-0.15	0.29	0.59
	3600	48.7	2.7	0.40	0.73	0.75	38.2	3.0	0.20	0.61	0.73	27.8	3.3	0.00	0.49	0.70	17.3	3.6	-0.20	0.37	0.67
71°F	2400	50.0	2.7	0.20	0.33	0.45	41.8	3.1	0.05	0.21	0.38	33.6	3.4	-0.11	0.10	0.30	25.4	3.8	-0.27	-0.02	0.23
	3000	52.2	2.7	0.21	0.50	0.49	42.8	3.0	0.02	0.32	0.42	33.4	3.3	-0.17	0.14	0.35	24.0	3.6	-0.36	-0.04	0.28
	3600	54.5	2.7	0.22	0.68	0.53	43.9	3.0	0.00	0.43	0.47	33.2	3.4	-0.23	0.19	0.40	22.6	3.7	-0.45	-0.06	0.34

7.5 TON STANDARD EFFICIENCY WITH KCB092S4 HUMIDITROL® OPERATING (2ND STAGE)

Entering Wet Bulb Temperature	Total Air Volume	Outdoor Air Temperature Entering Outdoor Coil																			
		65°F						75°F					85°F					95°F			
		Total Cool Cap.	Comp. Motor Input	Sensible To Total Ratio (S/T)			Total Cool Cap.	Comp. Motor Input	Sensible To Total Ratio (S/T)			Total Cool Cap.	Comp. Motor Input	Sensible To Total Ratio (S/T)			Total Cool Cap.	Comp. Motor Input	Sensible To Total Ratio (S/T)		
				Dry Bulb					Dry Bulb					Dry Bulb					Dry Bulb		
cfm	kBtuh	kW	75°F	80°F	85°F	kBtuh	kW	75°F	80°F	85°F	kBtuh	kW	75°F	80°F	85°F	kBtuh	kW	75°F	80°F	85°F	
63°F	2400	73.2	4.4	0.60	0.73	0.87	62.6	5.1	0.58	0.76	0.92	52.0	5.7	0.56	0.78	0.96	41.3	6.3	0.54	0.80	1.00
	3000	77.7	4.5	0.64	0.79	0.94	66.4	5.0	0.63	0.80	0.93	55.2	5.6	0.63	0.81	0.92	43.9	6.2	0.62	0.82	0.92
	3600	82.1	4.5	0.68	0.84	1.00	70.3	5.0	0.69	0.84	0.94	58.4	5.6	0.69	0.84	0.89	46.6	6.1	0.70	0.84	0.83
67°F	2400	80.6	4.5	0.43	0.57	0.71	70.5	5.1	0.40	0.55	0.72	60.4	5.7	0.37	0.52	0.73	50.3	6.3	0.34	0.50	0.75
	3000	85.8	4.5	0.46	0.61	0.76	74.5	5.1	0.44	0.63	0.76	63.1	5.7	0.41	0.65	0.75	51.8	6.3	0.39	0.67	0.74
	3600	91.0	4.5	0.49	0.65	0.82	78.4	5.1	0.47	0.71	0.79	65.8	5.6	0.45	0.77	0.77	53.2	6.2	0.43	0.83	0.74
71°F	2400	88.0	4.7	0.27	0.41	0.54	78.4	5.2	0.23	0.34	0.53	68.8	5.8	0.19	0.27	0.51	59.2	6.4	0.15	0.20	0.49
	3000	93.9	4.6	0.29	0.44	0.59	82.5	5.2	0.24	0.47	0.59	71.0	5.7	0.20	0.49	0.58	59.6	6.3	0.15	0.52	0.57
	3600	99.9	4.5	0.30	0.47	0.64	86.5	5.1	0.25	0.59	0.64	73.2	5.7	0.20	0.71	0.65	59.9	6.3	0.15	0.83	0.65

8.5 TON STANDARD EFFICIENCY KCB102S4 HUMIDITROL® OPERATING (1ST STAGE)

Entering Wet Bulb Temperature	Total Air Volume	Outdoor Air Temperature Entering Outdoor Coil																			
		65°F						75°F					85°F					95°F			
		Total Cool Cap.	Comp. Motor Input	Sensible To Total Ratio (S/T)			Total Cool Cap.	Comp. Motor Input	Sensible To Total Ratio (S/T)			Total Cool Cap.	Comp. Motor Input	Sensible To Total Ratio (S/T)			Total Cool Cap.	Comp. Motor Input	Sensible To Total Ratio (S/T)		
				Dry Bulb					Dry Bulb					Dry Bulb					Dry Bulb		
cfm	kBtuh	kW	75°F	80°F	85°F	kBtuh	kW	75°F	80°F	85°F	kBtuh	kW	75°F	80°F	85°F	kBtuh	kW	75°F	80°F	85°F	
63°F	2720	35.4	2.2	0.45	0.60	0.74	27.8	2.5	0.22	0.49	0.76	20.2	2.8	-0.02	0.38	0.79	12.6	3.0	-0.25	0.28	0.81
	3400	39.3	2.2	0.48	0.64	0.80	29.8	2.5	0.21	0.55	0.89	20.2	2.8	-0.07	0.46	0.99	10.7	3.0	-0.34	0.37	1.09
	4080	43.2	2.2	0.51	0.68	0.85	31.8	2.5	0.20	0.61	1.02	20.3	2.7	-0.11	0.54	1.20	8.9	3.0	-0.43	0.47	1.37
67°F	2720	40.4	2.2	0.31	0.45	0.59	32.7	2.5	0.08	0.32	0.55	25.0	2.8	-0.14	0.19	0.52	17.3	3.1	-0.37	0.05	0.48
	3400	44.1	2.2	0.32	0.48	0.64	34.6	2.5	0.05	0.35	0.65	25.0	2.8	-0.23	0.22	0.67	15.5	3.1	-0.51	0.09	0.68
	4080	47.9	2.2	0.34	0.51	0.69	36.5	2.5	0.01	0.38	0.75	25.1	2.8	-0.32	0.25	0.82	13.7	3.1	-0.65	0.12	0.89
71°F	2720	45.5	2.2	0.16	0.30	0.44	37.6	2.5	-0.06	0.14	0.34	29.8	2.9	-0.27	-0.01	0.25	21.9	3.2	-0.49	-0.17	0.15
	3400	49.0	2.2	0.17	0.32	0.48	39.4	2.5	-0.12	0.14	0.41	29.8	2.8	-0.40	-0.03	0.34	20.2	3.1	-0.68	-0.20	0.28
	4080	52.5	2.2	0.18	0.33	0.52	41.2	2.5	-0.18	0.14	0.48	29.9	2.8	-0.53	-0.05	0.44	18.5	3.1	-0.88	-0.24	0.40

8.5 TON STANDARD EFFICIENCY KCB102S4 HUMIDITROL® OPERATING (2ND STAGE)

Entering Wet Bulb Temperature	Total Air Volume	Outdoor Air Temperature Entering Outdoor Coil																			
		65°F						75°F					85°F					95°F			
		Total Cool Cap.	Comp. Motor Input	Sensible To Total Ratio (S/T)			Total Cool Cap.	Comp. Motor Input	Sensible To Total Ratio (S/T)			Total Cool Cap.	Comp. Motor Input	Sensible To Total Ratio (S/T)			Total Cool Cap.	Comp. Motor Input	Sensible To Total Ratio (S/T)		
				Dry Bulb					Dry Bulb					Dry Bulb					Dry Bulb		
cfm	kBtuh	kW	75°F	80°F	85°F	kBtuh	kW	75°F	80°F	85°F	kBtuh	kW	75°F	80°F	85°F	kBtuh	kW	75°F	80°F	85°F	
63°F	2720	85.8	4.5	0.61	0.77	0.94	75.7	5.2	0.60	0.78	0.96	65.6	5.9	0.59	0.79	0.98	55.5	6.6	0.58	0.80	1.00
	3400	91.9	4.5	0.66	0.83	1.00	80.8	5.2	0.65	0.83	1.00	69.7	5.9	0.65	0.84	1.00	58.6	6.6	0.64	0.84	1.00
	4080	98.0	4.5	0.71	0.89	1.06	85.9	5.2	0.71	0.89	1.04	73.8	5.9	0.70	0.89	1.02	61.7	6.6	0.70	0.89	1.00
67°F	2720	96.6	4.5	0.47	0.60	0.73	85.7	5.2	0.44	0.59	0.74	74.8	6.0	0.41	0.58	0.74	63.9	6.7	0.38	0.57	0.74
	3400	102.3	4.5	0.49	0.64	0.79	90.1	5.2	0.47	0.63	0.79	77.8	5.9	0.44	0.62	0.79	65.6	6.7	0.42	0.61	0.78
	4080	108.1	4.5	0.51	0.68	0.86	94.5	5.2	0.49	0.67	0.85	80.8	5.9	0.47	0.66	0.84	67.2	6.7	0.45	0.65	0.82
71°F	2720	107.4	4.5	0.33	0.43	0.52	95.7	5.3	0.28	0.40	0.51	84.1	6.0	0.23	0.36	0.50	72.4	6.8	0.18	0.33	0.48
	3400	112.8	4.5	0.32	0.45	0.59	99.4	5.3	0.28	0.43	0.58	86.0	6.0	0.23	0.40	0.57	72.5	6.7	0.19	0.38	0.57
	4080	118.2	4.5	0.31	0.48	0.65	103.0	5.3	0.28	0.46	0.65	87.9	6.0	0.24	0.44	0.65	72.7	6.7	0.20	0.42	0.65

HUMIDITROL® DEHUMIDIFICATION SYSTEM RATINGS

NOTE - For Temperatures and Capacities not shown in tables, see bulletin - Cooling Unit Rating Table Correction Factor Data in Miscellaneous Engineering Data section.

10 TON STANDARD EFFICIENCY WITH KCB120S4 HUMIDITROL® OPERATING (1ST STAGE)

Entering Wet Bulb Temperature	Total Air Volume	Outdoor Air Temperature Entering Outdoor Coil																							
		65°F						75°F						85°F						95°F					
		Total Cool Cap.	Comp. Motor Input	Sensible To Total Ratio (S/T)			Total Cool Cap.	Comp. Motor Input	Sensible To Total Ratio (S/T)			Total Cool Cap.	Comp. Motor Input	Sensible To Total Ratio (S/T)			Total Cool Cap.	Comp. Motor Input	Sensible To Total Ratio (S/T)						
				Dry Bulb					Dry Bulb					Dry Bulb					Dry Bulb						
cfm	kBtuh	kW	75°F	80°F	85°F	kBtuh	kW	75°F	80°F	85°F	kBtuh	kW	75°F	80°F	85°F	kBtuh	kW	75°F	80°F	85°F					
63°F	3200	39.2	2.6	0.51	0.66	0.82	28.3	2.9	0.25	0.60	0.88	17.5	3.2	0.00	0.54	0.94	6.7	3.6	-0.26	0.48	1.00				
	4000	42.7	2.6	0.54	0.72	0.91	29.9	2.9	0.23	0.71	0.94	17.1	3.2	-0.08	0.69	0.97	4.4	3.6	-0.39	0.67	1.00				
	4800	46.3	2.6	0.57	0.78	0.99	31.5	2.9	0.21	0.81	0.99	16.8	3.2	-0.16	0.84	1.00	2.0	3.5	-0.52	0.86	1.00				
67°F	3200	45.5	2.6	0.33	0.48	0.64	34.7	2.9	0.14	0.32	0.50	23.9	3.3	-0.05	0.16	0.36	13.0	3.6	-0.24	-0.01	0.23				
	4000	49.2	2.6	0.36	0.53	0.70	36.4	2.9	0.14	0.34	0.53	23.7	3.3	-0.08	0.14	0.36	10.9	3.6	-0.30	-0.05	0.19				
	4800	52.8	2.6	0.38	0.58	0.77	38.1	2.9	0.13	0.35	0.57	23.4	3.3	-0.11	0.12	0.36	8.7	3.6	-0.36	-0.10	0.16				
71°F	3200	53.5	2.6	0.20	0.33	0.47	41.8	3.0	-0.01	0.18	0.36	30.2	3.3	-0.21	0.02	0.26	18.6	3.7	-0.41	-0.13	0.15				
	4000	56.6	2.6	0.20	0.36	0.52	43.2	3.0	-0.03	0.19	0.40	29.8	3.3	-0.27	0.01	0.29	16.5	3.7	-0.51	-0.16	0.18				
	4800	59.6	2.6	0.21	0.39	0.56	44.6	3.0	-0.06	0.19	0.45	29.5	3.3	-0.33	0.00	0.33	14.4	3.7	-0.60	-0.19	0.21				

10 TON STANDARD EFFICIENCY WITH KCB120S4 HUMIDITROL® OPERATING (2ND STAGE)

Entering Wet Bulb Temperature	Total Air Volume	Outdoor Air Temperature Entering Outdoor Coil																							
		65°F						75°F						85°F						95°F					
		Total Cool Cap.	Comp. Motor Input	Sensible To Total Ratio (S/T)			Total Cool Cap.	Comp. Motor Input	Sensible To Total Ratio (S/T)			Total Cool Cap.	Comp. Motor Input	Sensible To Total Ratio (S/T)			Total Cool Cap.	Comp. Motor Input	Sensible To Total Ratio (S/T)						
				Dry Bulb					Dry Bulb					Dry Bulb					Dry Bulb						
cfm	kBtuh	kW	75°F	80°F	85°F	kBtuh	kW	75°F	80°F	85°F	kBtuh	kW	75°F	80°F	85°F	kBtuh	kW	75°F	80°F	85°F					
63°F	3200	107.2	5.2	0.62	0.76	0.90	92.4	6.0	0.62	0.79	0.93	77.6	6.8	0.61	0.81	0.97	62.8	7.6	0.60	0.84	1.00				
	4000	112.0	5.2	0.67	0.83	0.95	96.4	6.0	0.67	0.86	0.97	80.8	6.8	0.68	0.88	0.98	65.3	7.6	0.68	0.91	1.00				
	4800	116.9	5.2	0.71	0.90	1.00	100.5	6.0	0.73	0.93	1.00	84.1	6.8	0.74	0.95	1.00	67.7	7.6	0.76	0.98	1.00				
67°F	3200	119.0	5.2	0.46	0.59	0.72	103.7	6.0	0.43	0.59	0.74	88.5	6.9	0.41	0.58	0.75	73.2	7.7	0.38	0.57	0.77				
	4000	124.3	5.2	0.49	0.64	0.79	107.0	6.0	0.47	0.64	0.82	89.8	6.9	0.44	0.65	0.85	72.5	7.7	0.42	0.65	0.88				
	4800	129.5	5.2	0.52	0.69	0.86	110.3	6.0	0.50	0.70	0.91	91.0	6.9	0.48	0.72	0.95	71.8	7.7	0.46	0.73	1.00				
71°F	3200	132.8	5.3	0.32	0.44	0.57	116.3	6.1	0.28	0.42	0.57	99.7	7.0	0.23	0.40	0.57	83.2	7.8	0.19	0.38	0.56				
	4000	139.0	5.3	0.34	0.48	0.61	120.4	6.1	0.30	0.46	0.62	101.8	6.9	0.25	0.44	0.63	83.1	7.8	0.20	0.42	0.63				
	4800	145.2	5.3	0.37	0.51	0.66	124.5	6.1	0.32	0.49	0.67	103.8	6.9	0.27	0.48	0.69	83.1	7.8	0.22	0.46	0.70				

12.5 TON STANDARD EFFICIENCY KCB150S4 HUMIDITROL® OPERATING (1ST STAGE)

Entering Wet Bulb Temperature	Total Air Volume	Outdoor Air Temperature Entering Outdoor Coil																							
		65°F						75°F						85°F						95°F					
		Total Cool Cap.	Comp. Motor Input	Sensible To Total Ratio (S/T)			Total Cool Cap.	Comp. Motor Input	Sensible To Total Ratio (S/T)			Total Cool Cap.	Comp. Motor Input	Sensible To Total Ratio (S/T)			Total Cool Cap.	Comp. Motor Input	Sensible To Total Ratio (S/T)						
				Dry Bulb					Dry Bulb					Dry Bulb					Dry Bulb						
cfm	kBtuh	kW	75°F	80°F	85°F	kBtuh	kW	75°F	80°F	85°F	kBtuh	kW	75°F	80°F	85°F	kBtuh	kW	75°F	80°F	85°F					
63°F	3800	55.2	3.4	.48	.70	.91	45.8	3.8	.40	.67	.94	36.4	4.1	.25	.61	.97	27.0	4.5	.33	.51	.99				
	4400	58.2	3.5	.53	.77	1.00	47.9	3.8	.45	.76	1.00	37.6	4.1	.31	.73	1.00	27.3	4.5	.22	.69	1.00				
	5000	61.2	3.5	.57	.84	1.00	50.0	3.8	.50	.85	1.00	38.8	4.1	.33	.73	.90	27.6	4.5	.10	.89	1.00				
67°F	3800	63.7	3.5	.29	.48	.66	53.8	3.9	.20	.41	.63	44.0	4.2	.04	.32	.59	34.1	4.6	.03	.12	.52				
	4400	66.6	3.6	.32	.51	.73	56.1	3.9	.21	.46	.72	45.7	4.2	.05	.36	.68	35.3	4.6	-.04	.19	.65				
	5000	69.4	3.6	.33	.55	.79	58.4	3.9	.24	.51	.79	47.4	4.2	.08	.42	.79	36.4	4.6	-.10	.25	.60				
71°F	3800	72.2	3.6	.15	.31	.47	61.9	4.0	.05	.23	.42	51.6	4.3	-.10	.12	.35	41.3	4.6	-.28	-.07	.22				
	4400	74.9	3.7	.16	.33	.51	64.4	4.0	.05	.25	.45	53.8	4.3	-.11	.14	.39	43.3	4.7	-.29	-.06	.27				
	5000	77.7	3.7	.16	.35	.55	66.9	4.0	.05	.28	.51	56.1	4.4	-.12	.16	.45	45.3	4.7	-.30	-.04	.33				

12.5 TON STANDARD EFFICIENCY KCB150S4 HUMIDITROL® OPERATING (2ND STAGE)

Entering Wet Bulb Temperature	Total Air Volume	Outdoor Air Temperature Entering Outdoor Coil																							
		65°F						75°F						85°F						95°F					
		Total Cool Cap.	Comp. Motor Input	Sensible To Total Ratio (S/T)			Total Cool Cap.	Comp. Motor Input	Sensible To Total Ratio (S/T)			Total Cool Cap.	Comp. Motor Input	Sensible To Total Ratio (S/T)			Total Cool Cap.	Comp. Motor Input	Sensible To Total Ratio (S/T)						
				Dry Bulb					Dry Bulb					Dry Bulb					Dry Bulb						
cfm	kBtuh	kW	75°F	80°F	85°F	kBtuh	kW	75°F	80°F	85°F	kBtuh	kW	75°F	80°F	85°F	kBtuh	kW	75°F	80°F	85°F					
63°F	3800	122.7	7.3	.63	.79	.96	110.6	8.0	.62	.80	.99	98.6	8.8	.61	.81	1.00	86.5	9.6	.60	.82	1.00				
	4400	127.4	7.3	.66	.82	.97	114.4	8.1	.65	.83	1.00	101.4	8.8	.65	.84	1.00	88.4	9.6	.64	.85	1.00				
	5000	132.1	7.3	.69	.84	.99	118.2	8.1	.69	.86	1.00	104.2	8.9	.69	.87	1.00	90.3	9.6	.69	.88	1.00				
67°F	3800	137.7	7.5	.47	.62	.76	124.7	8.2	.44	.61	.78	111.8	9.0	.42	.60	.79	98.8	9.8	.39	.60	.80				
	4400	142.5	7.5	.49	.64	.79	128.7	8.3	.46	.63	.80	115.0	9.0	.44	.63	.81	101.3	9.8	.42	.62	.83				
	5000	147.2	7.6	.50	.66	.81	132.7	8.3	.48	.65	.82	118.2	9.1	.46	.65	.84	103.7	9.8	.44	.65	.85				
71°F	3800	152.7	7.7	.31	.44	.57	138.8	8.4	.27	.42	.56	125.0	9.2	.23	.39	.55	111.1	10.0	.19	.37	.55				
	4400	157.5	7.7	.31	.46	.60	143.1	8.5	.27	.43	.60	128.6	9.2	.23	.41	.59	114.2	10.0	.19	.39	.59				
	5000	162.4	7.8	.31	.47	.63	147.3	8.5	.27	.45	.63	132.2	9.3	.23	.43	.63	117.2	10.0	.19	.41	.63				

BLOWER DATA

092S STANDARD EFFICIENCY BELT DRIVE BLOWER – BASE UNIT

BLOWER TABLE INCLUDES RESISTANCE FOR BASE UNIT ONLY (NO HEAT SECTION) WITH DRY INDOOR COIL AND AIR FILTERS IN PLACE. FOR ALL UNITS ADD:

- 1 – Wet indoor coil air resistance of selected unit.
- 2 – Any factory installed options air resistance (heat section, economizer, etc.)
- 3 – Any field installed accessories air resistance (duct resistance, diffuser, etc.)

Then determine from blower table blower motor output required.

See page 31 for blower motors and drives.

See page 31 for wet coil and option/accessory air resistance data.

MINIMUM AIR VOLUME REQUIRED FOR USE WITH OPTIONAL ELECTRIC HEAT (Maximum Static Pressure - 2.0 in. w.g.)

7.5 kW, 15 kW, 22.5 kW, 30 kW and 45 kW - 2800 cfm

Total Air Volume cfm	Total Static Pressure – in. w.g.																									
	0.2		0.4		0.6		0.8		1.0		1.2		1.4		1.6		1.8		2		2.2		2.4		2.6	
	RPM	BHP	RPM	BHP	RPM	BHP	RPM	BHP	RPM	BHP	RPM	BHP	RPM	BHP	RPM	BHP	RPM	BHP	RPM	BHP	RPM	BHP	RPM	BHP	RPM	BHP
1750	608	0.05	651	0.03	696	0.06	744	0.22	794	0.60	845	0.95	894	1.24	934	1.38	978	1.47	1047	1.66	1120	1.89	1179	2.15	1230	2.40
2000	615	0.07	657	0.05	702	0.10	748	0.36	797	0.72	846	1.05	892	1.30	933	1.45	977	1.55	1049	1.75	1124	2.00	1181	2.23	1234	2.47
2250	624	0.09	664	0.07	707	0.14	753	0.50	800	0.84	847	1.15	892	1.38	934	1.53	979	1.65	1051	1.86	1126	2.12	1183	2.36	1238	2.62
2500	632	0.11	672	0.09	714	0.29	758	0.64	803	0.97	849	1.26	893	1.48	936	1.63	983	1.75	1052	1.96	1124	2.22	1184	2.49	1241	2.77
2750	641	0.13	680	0.11	721	0.45	763	0.78	807	1.09	852	1.37	896	1.58	940	1.74	989	1.88	1053	2.08	1121	2.34	1185	2.63	1244	2.93
3000	651	0.15	689	0.29	728	0.61	770	0.93	812	1.23	856	1.49	901	1.70	947	1.87	996	2.02	1055	2.21	1120	2.47	1186	2.78	1248	3.10
3250	661	0.17	698	0.46	737	0.78	777	1.09	819	1.38	862	1.63	908	1.84	955	2.01	1004	2.17	1059	2.36	1122	2.62	1189	2.94	1252	3.28
3500	672	0.36	708	0.65	746	0.95	786	1.25	827	1.53	870	1.78	916	1.99	965	2.17	1013	2.33	1065	2.52	1126	2.79	1193	3.12	1257	3.47
3750	684	0.56	719	0.85	756	1.14	795	1.43	836	1.70	880	1.95	927	2.16	976	2.34	1023	2.51	1073	2.71	1133	2.98	1198	3.32	1263	3.67
4000	697	0.78	731	1.05	768	1.34	807	1.62	848	1.89	892	2.13	940	2.34	988	2.53	1034	2.71	1083	2.91	1141	3.19	1205	3.53	1270	3.89
4250	710	1.00	745	1.27	781	1.55	819	1.83	861	2.09	906	2.33	954	2.55	1001	2.74	1046	2.93	1094	3.14	1151	3.42	1214	3.76	1278	4.12

OUTDOOR SOUND DATA

Unit Model Number	Octave Band Sound Power Levels dBA, re 10 ⁻¹² Watts - Center Frequency - Hz							¹ Sound Rating Number (dBA)
	125	250	500	1000	2000	4000	8000	
092, 102 and 120	76	79	84	83	79	73	66	88
150	75	81	87	85	80	73	67	90

Note - The octave sound power data does not include tonal corrections.

¹ Sound Rating Number according to AHRI Standard 270-95 or AHRI Standard 370-2001 (includes pure tone penalty). Sound Rating Number is the overall A-Weighted Sound Power Level, (LWA), dBA (100 Hz to 10,000 Hz).

BLOWER DATA

092H AND 102H HIGH EFFICIENCY BELT DRIVE BLOWER – BASE UNIT

BLOWER TABLE INCLUDES RESISTANCE FOR BASE UNIT ONLY (NO HEAT SECTION) WITH DRY INDOOR COIL AND AIR FILTERS IN PLACE. FOR ALL UNITS ADD:

- 1 – Wet indoor coil air resistance of selected unit.
- 2 – Any factory installed options air resistance (heat section, economizer, etc.)
- 3 – Any field installed accessories air resistance (duct resistance, diffuser, etc.)

Then determine from blower table blower motor output required.

See page 31 for blower motors and drives.

See page 31 for wet coil and option/accessory air resistance data.

MINIMUM AIR VOLUME REQUIRED FOR USE WITH OPTIONAL ELECTRIC HEAT (Maximum Static Pressure - 2.0 in. w.g.)

7.5 kW, 15 kW, 22.5 kW, 30 kW and 45 kW - 2800 cfm

Total Air Volume cfm	Total Static Pressure – in. w.g.																										
	0.2		0.4		0.6		0.8		1.0		1.2		1.4		1.6		1.8		2.0		2.2		2.4		2.6		
	RPM	BHP	RPM	BHP	RPM	BHP	RPM	BHP	RPM	BHP	RPM	BHP	RPM	BHP	RPM	BHP	RPM	BHP	RPM	BHP	RPM	BHP	RPM	BHP	RPM	BHP	RPM
1750	481	0.21	549	0.4	618	0.57	688	0.7	758	0.82	824	0.93	885	1.08	941	1.23	991	1.39	1038	1.54	1082	1.68	1124	1.82	1166	1.95	
2000	493	0.29	561	0.47	629	0.64	700	0.77	768	0.9	832	1.02	892	1.17	946	1.33	995	1.49	1041	1.66	1085	1.81	1126	1.97	1167	2.12	
2250	507	0.37	574	0.56	643	0.72	712	0.86	779	0.99	842	1.13	900	1.28	953	1.44	1001	1.61	1045	1.78	1088	1.95	1128	2.12	1168	2.3	
2500	521	0.46	588	0.64	657	0.81	727	0.95	792	1.09	853	1.24	909	1.4	960	1.57	1007	1.74	1050	1.93	1091	2.11	1130	2.29	1170	2.48	
2750	537	0.56	604	0.74	674	0.91	743	1.06	806	1.21	865	1.36	920	1.53	969	1.71	1014	1.89	1055	2.08	1095	2.27	1133	2.47	1172	2.66	
3000	554	0.67	622	0.86	692	1.02	760	1.18	822	1.34	878	1.5	931	1.68	979	1.86	1021	2.06	1061	2.26	1099	2.46	1136	2.65	1174	2.85	
3250	572	0.78	641	0.98	712	1.15	778	1.32	838	1.49	892	1.66	943	1.84	989	2.03	1030	2.24	1068	2.45	1105	2.65	1141	2.85	1178	3.06	
3500	592	0.9	663	1.12	733	1.3	798	1.47	855	1.65	907	1.83	956	2.02	1000	2.22	1039	2.44	1076	2.65	1111	2.86	1146	3.07	1183	3.27	
3750	614	1.04	687	1.28	756	1.47	818	1.65	872	1.83	923	2.02	970	2.22	1011	2.43	1049	2.65	1084	2.87	1118	3.09	1152	3.29	1189	3.51	
4000	639	1.22	713	1.48	780	1.66	838	1.83	890	2.02	939	2.22	984	2.44	1023	2.66	1059	2.89	1093	3.11	1126	3.33	1160	3.54	1197	3.77	
4250	667	1.43	741	1.69	805	1.86	859	2.02	909	2.22	956	2.45	998	2.68	1036	2.92	1070	3.15	1103	3.37	1135	3.59	1169	3.81	1207	4.05	

BLOWER DATA

102S AND 120S (MSAV®)

(Multi-Stage Air Volume) STANDARD EFFICIENCY BELT DRIVE BLOWER – BASE UNIT

BLOWER TABLE INCLUDES RESISTANCE FOR BASE UNIT ONLY (NO HEAT SECTION) WITH DRY INDOOR COIL AND AIR FILTERS IN PLACE. FOR ALL UNITS ADD:

- 1 – Wet indoor coil air resistance of selected unit.
- 2 – Any factory installed options air resistance (heat section, economizer, etc.)
- 3 – Any field installed accessories air resistance (duct resistance, diffuser, etc.)

Then determine from blower table blower motor output required.

See page 31 for blower motors and drives.

See page 31 for wet coil and option/accessory air resistance data.

MINIMUM AIR VOLUME REQUIRED FOR USE WITH OPTIONAL ELECTRIC HEAT (Maximum Static Pressure - 2.0 in. w.g.)

15 kW, 22.5 kW, 30 kW and 45 kW - 2800 cfm

60 kW - 4000 cfm

Total Air Volume cfm	Total Static Pressure – in. w.g.																									
	0.2		0.4		0.6		0.8		1.0		1.2		1.4		1.6		1.8		2		2.2		2.4		2.6	
	RPM	BHP	RPM	BHP	RPM	BHP	RPM	BHP	RPM	BHP	RPM	BHP	RPM	BHP	RPM	BHP	RPM	BHP	RPM	BHP	RPM	BHP	RPM	BHP	RPM	BHP
2000	593	0.11	636	0.07	682	0.10	731	0.22	784	0.60	840	0.96	898	1.26	948	1.38	996	1.47	1045	1.57	1092	1.71	1140	1.92	1188	2.32
2250	604	0.15	645	0.11	690	0.15	739	0.39	790	0.74	846	1.08	901	1.34	953	1.48	1002	1.57	1052	1.70	1100	1.86	1149	2.09	1197	2.42
2500	615	0.19	655	0.15	699	0.20	747	0.55	797	0.89	851	1.20	906	1.44	959	1.58	1009	1.68	1059	1.83	1108	2.01	1158	2.26	1206	2.52
2750	626	0.23	666	0.19	709	0.37	755	0.71	805	1.03	858	1.32	912	1.55	966	1.70	1017	1.81	1067	1.97	1117	2.17	1166	2.44	1215	2.71
3000	637	0.27	677	0.24	719	0.55	764	0.87	813	1.18	866	1.45	920	1.67	975	1.82	1026	1.96	1076	2.13	1126	2.35	1176	2.63	1225	2.92
3250	650	0.31	688	0.43	730	0.73	775	1.04	823	1.34	875	1.60	930	1.81	985	1.97	1036	2.12	1086	2.31	1136	2.54	1186	2.83	1235	3.13
3500	663	0.35	700	0.63	741	0.92	786	1.22	834	1.50	886	1.76	942	1.96	997	2.14	1048	2.31	1097	2.51	1147	2.75	1196	3.04	1245	3.35
3750	676	0.57	714	0.84	754	1.12	798	1.41	846	1.68	899	1.93	956	2.14	1010	2.32	1060	2.51	1109	2.72	1158	2.98	1207	3.27	1255	3.58
4000	691	0.79	728	1.05	768	1.33	812	1.61	860	1.88	914	2.12	971	2.34	1023	2.53	1072	2.73	1121	2.95	1169	3.22	1218	3.51	1266	3.83
4250	706	1.03	743	1.28	783	1.55	827	1.82	876	2.09	931	2.33	987	2.55	1037	2.76	1085	2.97	1133	3.20	1181	3.47	1229	3.76	1277	4.08
4500	722	1.27	759	1.52	799	1.78	844	2.05	894	2.31	949	2.56	1003	2.79	1052	3.00	1098	3.22	1145	3.46	1193	3.73	1241	4.03	1289	4.34
4750	739	1.53	776	1.77	817	2.03	862	2.30	913	2.56	968	2.81	1020	3.04	1066	3.27	1112	3.49	1158	3.74	1205	4.01	1253	4.30	1301	4.61
5000	757	1.79	794	2.04	835	2.30	882	2.56	934	2.83	988	3.08	1036	3.32	1081	3.55	1125	3.78	1171	4.02	1218	4.29	1265	4.59	1312	4.89

BLOWER DATA

120H AND 120S (CAV) HIGH EFFICIENCY AND 150S STANDARD EFFICIENCY BELT DRIVE BLOWER – BASE UNIT

BLOWER TABLE INCLUDES RESISTANCE FOR BASE UNIT ONLY (NO HEAT SECTION) WITH DRY INDOOR COIL AND AIR FILTERS IN PLACE. FOR ALL UNITS ADD:

- 1 – Wet indoor coil air resistance of selected unit.
- 2 – Any factory installed options air resistance (heat section, economizer, etc.)
- 3 – Any field installed accessories air resistance (duct resistance, diffuser, etc.)

Then determine from blower table blower motor output required.

See page 31 for blower motors and drives.

See page 31 for wet coil and option/accessory air resistance data.

MINIMUM AIR VOLUME REQUIRED FOR USE WITH OPTIONAL ELECTRIC HEAT (Maximum Static Pressure - 2.0 in. w.g.)

15 kW, 22.5 kW, 30 kW and 45 kW - 2800 cfm

60 kW - 4000 cfm

Total Air Volume cfm	Total Static Pressure – in. w.g.																										
	0.2		0.4		0.6		0.8		1.0		1.2		1.4		1.6		1.8		2.0		2.2		2.4		2.6		
	RPM	BHP	RPM	BHP	RPM	BHP	RPM	BHP	RPM	BHP	RPM	BHP	RPM	BHP	RPM	BHP	RPM	BHP	RPM	BHP	RPM	BHP	RPM	BHP	RPM	BHP	RPM
2000	497	0.25	558	0.44	624	0.6	694	0.74	764	0.85	830	0.99	889	1.16	943	1.34	994	1.52	1045	1.71	1096	1.89	1146	2.08	1197	2.27	
2250	511	0.34	573	0.52	638	0.68	708	0.82	776	0.94	839	1.09	896	1.26	948	1.45	998	1.64	1048	1.83	1098	2.01	1149	2.2	1200	2.4	
2500	527	0.44	589	0.62	654	0.78	723	0.91	789	1.05	850	1.21	904	1.39	955	1.58	1003	1.77	1052	1.96	1101	2.14	1152	2.33	1203	2.53	
2750	545	0.55	606	0.72	672	0.88	740	1.03	804	1.17	861	1.34	914	1.53	962	1.72	1010	1.92	1057	2.10	1105	2.29	1154	2.47	1206	2.68	
3000	564	0.66	626	0.84	692	1.01	759	1.16	819	1.32	874	1.49	924	1.68	971	1.88	1017	2.08	1063	2.26	1110	2.44	1158	2.63	1208	2.83	
3250	585	0.79	648	0.98	714	1.14	778	1.31	836	1.48	887	1.66	935	1.86	981	2.06	1026	2.26	1071	2.45	1117	2.63	1163	2.80	1213	3.00	
3500	607	0.93	672	1.13	737	1.31	798	1.48	852	1.66	901	1.85	948	2.05	993	2.26	1037	2.46	1081	2.65	1125	2.83	1171	3.01	1221	3.21	
3750	632	1.10	698	1.31	762	1.50	819	1.67	869	1.86	915	2.05	961	2.25	1005	2.47	1049	2.68	1092	2.88	1136	3.05	1181	3.24	1231	3.45	
4000	660	1.30	726	1.52	787	1.70	838	1.87	885	2.06	930	2.26	974	2.48	1018	2.71	1062	2.93	1105	3.12	1149	3.30	1194	3.49	1245	3.72	
4250	691	1.53	755	1.75	810	1.91	857	2.07	901	2.27	945	2.50	990	2.74	1034	2.98	1077	3.20	1120	3.39	1163	3.58	1210	3.79	1262	4.03	
4500	724	1.78	783	1.98	831	2.12	874	2.28	917	2.50	962	2.75	1006	3.02	1051	3.27	1094	3.49	1137	3.70	1181	3.89	1228	4.11	1281	4.38	
4750	757	2.05	809	2.20	851	2.33	891	2.51	935	2.76	980	3.05	1025	3.33	1070	3.59	1113	3.82	1156	4.03	1201	4.24	1249	4.47	1303	4.75	
5000	787	2.31	831	2.43	870	2.57	910	2.78	954	3.06	1000	3.38	1046	3.68	1091	3.95	1135	4.19	1178	4.40	1224	4.62	1272	4.86	1325	5.13	
5250	814	2.55	852	2.66	889	2.83	930	3.09	975	3.41	1023	3.76	1070	4.08	1115	4.35	1159	4.59	1203	4.81	1248	5.03	1297	5.27	1350	5.53	
5500	835	2.78	871	2.91	909	3.13	952	3.44	999	3.81	1049	4.18	1096	4.51	1142	4.79	1186	5.03	1229	5.24	1275	5.46	1324	5.69	---	---	
5750	854	3.01	890	3.19	930	3.48	977	3.86	1027	4.27	1078	4.66	1126	4.99	1171	5.26	1214	5.49	1258	5.70	---	---	---	---	---	---	
6000	871	3.26	910	3.53	955	3.90	1006	4.34	1060	4.80	1111	5.19	1158	5.51	---	---	---	---	---	---	---	---	---	---	---	---	
6250	890	3.57	934	3.94	985	4.41	1041	4.91	1096	5.38	---	---	---	---	---	---	---	---	---	---	---	---	---	---	---	---	

BLOWER DATA

FACTORY INSTALLED BELT DRIVE KIT SPECIFICATIONS

Nominal hp	Maximum hp	Drive Kit Number	RPM Range
2	2.3	1	590 - 890
2	2.3	2	800 - 1105
2	2.3	3	795 - 1195
3	3.45	4	730 - 970
3	3.45	5	940 - 1200
3	3.45	6	1015 - 1300
5	5.75	10	900 - 1135
5	5.75	11	1040 - 1315
5	5.75	12	1125 - 1425

NOTE - Using total air volume and system static pressure requirements determine from blower performance tables rpm and motor output required. Maximum usable output of motors furnished are shown. In Canada, nominal motor output is also maximum usable motor output. If motors of comparable output are used, be sure to keep within the service factor limitations outlined on the motor nameplate.

NOTE - Units equipped with MSAV® (Multi-Stage Air Volume) option are limited to a motor service factor of 1.0.

POWER EXHAUST FAN PERFORMANCE

Return Air System Static Pressure	Air Volume Exhausted
in. w.g.	cfm
0	3175
0.05	2955
0.10	2685
0.15	2410
0.20	2165
0.25	1920
0.30	1420
0.35	1200

FACTORY INSTALLED OPTIONS/FIELD INSTALLED ACCESSORY AIR RESISTANCE - in. w.g.

Air Volume cfm	Wet Indoor Coil		Electric Heat	Economizer	Humiditrol® Condenser Reheat Coil	Filters		Return Air Adaptor Plate
	092, 102	120, 150				MERV 8	MERV 13	
1750	0.04	0.04	0.03	0.05	0.02	0.01	0.03	0.00
2000	0.05	0.05	0.03	0.06	0.02	0.01	0.03	0.00
2250	0.06	0.06	0.04	0.08	0.02	0.01	0.04	0.00
2500	0.07	0.07	0.04	0.11	0.03	0.01	0.05	0.00
2750	0.08	0.08	0.05	0.12	0.03	0.02	0.05	0.00
3000	0.10	0.09	0.06	0.13	0.03	0.02	0.06	0.02
3250	0.11	0.10	0.06	0.15	0.04	0.02	0.06	0.02
3500	0.12	0.11	0.09	0.15	0.04	0.03	0.07	0.04
3750	0.14	0.13	0.09	0.15	0.05	0.03	0.08	0.07
4000	0.15	0.14	0.09	0.19	0.05	0.04	0.08	0.09
4250	0.17	0.15	0.13	0.19	0.06	0.04	0.09	0.11
4500	0.19	0.17	0.14	0.22	0.07	0.04	0.09	0.12
4750	0.20	0.18	0.17	0.25	0.07	0.05	0.10	0.16
5000	0.22	0.20	0.20	0.29	0.08	0.06	0.10	0.18
5250	0.24	0.22	0.22	0.32	0.08	0.06	0.11	0.19
5500	0.25	0.23	0.25	0.34	0.09	0.07	0.12	0.22
5750	0.27	0.25	0.31	0.45	0.10	0.07	0.12	0.25
6000	0.29	0.27	0.33	0.52	0.10	0.08	0.13	0.27

BLOWER DATA

CEILING DIFFUSERS AIR RESISTANCE - in. w.g.

Unit Size	RTD11 Step-Down Diffuser				FD11 Flush Diffuser
	Air Volume cfm	2 Ends Open	1 Side, 2 Ends Open	All Ends & Sides Open	
092 Models	2400	0.21	0.18	0.15	0.14
	2600	0.24	0.21	0.18	0.17
	2800	0.27	0.24	0.21	0.20
	3000	0.32	0.29	0.25	0.25
	3200	0.41	0.37	0.32	0.31
	3400	0.50	0.45	0.39	0.37
	3600	0.61	0.54	0.48	0.44
102 & 120 Models	3800	0.73	0.63	0.57	0.51
	3600	0.36	0.28	0.23	0.15
	3800	0.40	0.32	0.26	0.18
	4000	0.44	0.36	0.29	0.21
	4200	0.49	0.40	0.33	0.24
	4400	0.54	0.44	0.37	0.27
	4600	0.60	0.49	0.42	0.31
	4800	0.65	0.53	0.46	0.35
150 Models	5000	0.69	0.58	0.50	0.39
	5200	0.75	0.62	0.54	0.43
	4200	0.22	0.19	0.16	0.10
	4400	0.28	0.24	0.20	0.12
	4600	0.34	0.29	0.24	0.15
	4800	0.40	0.34	0.29	0.19
	5000	0.46	0.39	0.34	0.23
	5200	0.52	0.44	0.39	0.27
	5400	0.58	0.49	0.43	0.31
5600	0.64	0.54	0.47	0.35	
5800	0.70	0.59	0.51	0.39	

CEILING DIFFUSER AIR THROW DATA

Model No.	Air Volume cfm	¹ Effective Throw Range	
		RTD11 Step-Down	FD11 Flush
		ft.	ft.
092 Models	2600	24 - 29	19 - 24
	2800	25 - 30	20 - 28
	3000	27 - 33	21 - 29
	3200	28 - 35	22 - 29
	3400	30 - 37	22 - 30
102, 120 Models	3600	25 - 33	22 - 29
	3800	27 - 35	22 - 30
	4000	29 - 37	24 - 33
	4200	32 - 40	26 - 35
	4400	34 - 42	28 - 37
150 Models	5600	39 - 49	28 - 37
	5800	42 - 51	29 - 38
	6000	44 - 54	40 - 50
	6200	45 - 55	42 - 51
	6400	46 - 55	43 - 52
	6600	47 - 56	45 - 56

¹ Throw is the horizontal or vertical distance an air stream travels on leaving the outlet or diffuser before the maximum velocity is reduced to 50 ft. per minute. Four sides open.

ELECTRICAL/ELECTRIC HEAT DATA

7.5 TON

7.5 TON STANDARD EFFICIENCY (R-410A)

KCB092S4

¹ Voltage - 60hz		208/230V - 3 Ph			460V - 3 Ph			575V - 3 Ph		
Compressor 1	Rated Load Amps	13.1			6.1			4.4		
	Locked Rotor Amps	83.1			41			33		
Compressor 2	Rated Load Amps	13.1			6.1			4.4		
	Locked Rotor Amps	83.1			41			33		
Outdoor Fan Motors (2)	Full Load Amps (total)	2.4 (4.8)			1.3 (2.6)			1 (2)		
Power Exhaust (1) 0.33 HP	Full Load Amps	2.4			1.3			1		
Service Outlet 115V GFI (amps)		15			15			20		
Indoor Blower Motor	Horsepower	2	3	5	2	3	5	2	3	5
	Full Load Amps	7.5	10.5	16.7	3.4	4.8	7.6	2.7	3.9	6.1
² Maximum Overcurrent Protection	Unit Only	50	50	60	25	25	30	15	20	20
	With (1) 0.33 HP Power Exhaust	50	60	70	25	25	30	20	20	25
³ Minimum Circuit Ampacity	Unit Only	42	45	52	20	22	25	15	16	19
	With (1) 0.33 HP Power Exhaust	45	48	55	22	23	26	16	17	20

ELECTRIC HEAT DATA

Electric Heat Voltage			208V	240V	208V	240V	208V	240V	480V	480V	480V	600V	600V	600V
² Maximum Overcurrent Protection	Unit+ Electric Heat and (1) 0.33 HP Power Exhaust	7.5 kW	50	50	50	50	60	60	25	25	30	15	20	20
		15 kW	50	60	60	60	60	70	30	30	35	25	25	30
		22.5 kW	70	80	80	90	80	90	40	40	45	35	35	35
		30 kW	90	100	100	110	100	125	50	60	60	40	45	45
		45 kW	150	150	150	150	150	175	80	80	80	60	60	60
³ Minimum Circuit Ampacity	Unit+ Electric Heat and (1) 0.33 HP Power Exhaust	7.5 kW	42	42	45	45	52	52	20	22	25	15	16	19
		15 kW	49	55	53	59	60	66	27	29	33	22	23	26
		22.5 kW	69	78	72	81	80	89	39	40	44	31	32	35
		30 kW	88	100	92	104	100	112	50	52	55	40	41	44
		45 kW	127	145	131	149	139	157	72	74	78	58	60	62
² Maximum Overcurrent Protection	Unit+ Electric Heat and (1) 0.33 HP Power Exhaust	7.5 kW	50	50	60	60	70	70	25	25	30	20	20	25
		15 kW	60	60	60	70	70	70	30	35	35	25	25	30
		22.5 kW	80	90	80	90	90	100	40	45	45	35	35	40
		30 kW	100	110	100	110	110	125	60	60	60	45	45	45
		45 kW	150	150	150	175	150	175	80	80	80	60	70	70
³ Minimum Circuit Ampacity	Unit+ Electric Heat and (1) 0.33 HP Power Exhaust	7.5 kW	45	45	48	48	55	55	22	23	26	16	17	20
		15 kW	52	58	56	62	63	69	29	31	34	23	25	27
		22.5 kW	72	81	75	84	83	92	40	42	45	32	34	36
		30 kW	91	103	95	107	103	115	51	53	57	41	43	45
		45 kW	130	148	134	152	142	160	74	76	79	59	61	64

ELECTRICAL ACCESSORIES

Disconnect	7.5 kW	54W56			54W56			54W56		
	15 kW	54W56			54W56			54W56		
	22.5 kW	54W56			54W56			54W56		
	30 kW	54W57			54W56			54W56		
	45 kW	54W57			54W56			54W56		

NOTE - All units have a minimum Short Circuit Current Rating (SCCR) of 5000 amps.

¹ Extremes of operating range are plus and minus 10% of line voltage.

² HACR type breaker or fuse.

³ Refer to National or Canadian Electrical Code manual to determine wire, fuse and disconnect size requirements.

ELECTRICAL/ELECTRIC HEAT DATA

7.5 TON

7.5 TON HIGH EFFICIENCY (R-410A)

KCA092H4

¹ Voltage - 60hz		208/230V - 3 Ph			460V - 3 Ph			575V - 3 Ph		
Compressor 1	Rated Load Amps	11.6			5.5			4.7		
	Locked Rotor Amps	86			37			34		
Compressor 2	Rated Load Amps	11.6			5.5			4.7		
	Locked Rotor Amps	86			37			34		
Outdoor Fan Motors (2)	Full Load Amps (total)	2.4 (4.8)			1.3 (2.6)			1 (2)		
Power Exhaust (1) 0.33 HP	Full Load Amps	2.4			1.3			1		
Service Outlet 115V GFI (amps)		15			15			20		
Indoor Blower Motor	Horsepower	2	3	5	2	3	5	2	3	5
	Full Load Amps	7.5	10.6	16.7	3.4	4.8	7.6	2.7	3.9	6.1
² Maximum Overcurrent Protection	Unit Only	45	50	60	20	25	30	20	20	25
	With (1) 0.33 HP Power Exhaust	50	50	60	25	25	30	20	20	25
³ Minimum Circuit Ampacity	Unit Only	39	42	49	19	20	24	16	17	20
	With (1) 0.33 HP Power Exhaust	41	44	52	20	22	25	17	18	21

ELECTRIC HEAT DATA

Electric Heat Voltage			208V	240V	208V	240V	208V	240V	480V	480V	480V	600V	600V	600V
² Maximum Overcurrent Protection	Unit+	7.5 kW	45	45	50	50	60	60	20	25	30	20	20	25
	Electric Heat and (1) 0.33 HP Power Exhaust	15 kW	50	60	60	60	60	70	30	30	35	25	25	30
		22.5 kW	70	80	80	90	80	90	40	40	45	35	35	35
		30 kW	90	100	100	110	100	125	50	60	60	40	45	45
³ Minimum Circuit Ampacity	Unit+	7.5 kW	39	39	42	42	49	49	19	20	24	16	17	20
	Electric Heat and (1) 0.33 HP Power Exhaust	15 kW	49	55	53	59	60	66	27	29	33	22	23	26
		22.5 kW	69	78	72	81	80	89	39	40	44	31	32	35
		30 kW	88	100	92	104	100	112	50	52	55	40	41	44
² Maximum Overcurrent Protection	Unit+	7.5 kW	50	50	50	50	60	60	25	25	30	20	20	25
	Electric Heat and (1) 0.33 HP Power Exhaust	15 kW	60	60	60	70	70	70	30	35	35	25	25	30
		22.5 kW	80	90	80	90	90	100	40	45	45	35	35	40
		30 kW	100	110	100	110	110	125	60	60	60	45	45	45
³ Minimum Circuit Ampacity	Unit+	7.5 kW	41	41	44	44	52	52	20	22	25	17	18	21
	Electric Heat and (1) 0.33 HP Power Exhaust	15 kW	52	58	56	62	63	69	29	31	34	23	25	27
		22.5 kW	72	81	75	84	83	92	40	42	45	32	34	36
		30 kW	91	103	95	107	103	115	51	53	57	41	43	45
		45 kW	130	148	134	152	142	160	74	76	79	59	61	64

ELECTRICAL ACCESSORIES

Disconnect	7.5 kW	54W56			54W56		
	15 kW	54W56			54W56		
	22.5 kW	54W56	54W57		54W56		
	30 kW	54W57			54W56		
	45 kW	54W57			54W56		

NOTE - All units have a minimum Short Circuit Current Rating (SCCR) of 5000 amps.

¹ Extremes of operating range are plus and minus 10% of line voltage.

² HACR type breaker or fuse.

³ Refer to National or Canadian Electrical Code manual to determine wire, fuse and disconnect size requirements.

ELECTRICAL/ELECTRIC HEAT DATA

8.5 TON

8.5 TON STANDARD EFFICIENCY (R-410A)

KCB102S4

¹ Voltage - 60hz		208/230V - 3 Ph			460V - 3 Ph			575V - 3 Ph		
Compressor 1	Rated Load Amps	11.9			6.7			5.4		
	Locked Rotor Amps	109			59			40		
Compressor 2	Rated Load Amps	11.9			6.7			5.4		
	Locked Rotor Amps	109			59			40		
Outdoor Fan Motors (2)	Full Load Amps	2.4			1.3			1		
	(total)	(4.8)			(2.6)			(2)		
Power Exhaust (1) 0.33 HP	Full Load Amps	2.4			1.3			1		
Service Outlet 115V GFI (amps)		15			15			20		
Indoor Blower Motor	Horsepower	2	3	5	2	3	5	2	3	5
	Full Load Amps	7.5	10.6	16.7	3.4	4.8	7.6	2.7	3.9	6.1
² Maximum Overcurrent Protection	Unit Only	50	50	60	25	25	30	20	20	25
	With (1) 0.33 HP Power Exhaust	50	50	60	25	30	30	20	20	25
³ Minimum Circuit Ampacity	Unit Only	40	43	50	22	23	26	17	19	21
	With (1) 0.33 HP Power Exhaust	42	45	52	23	24	27	18	20	22

ELECTRIC HEAT DATA

Electric Heat Voltage			208V	240V	208V	240V	208V	240V	480V	480V	480V	600V	600V	600V
² Maximum Overcurrent Protection	Unit+ Electric Heat and (1) 0.33 HP Power Exhaust	7.5 kW	50	50	50	50	60	60	25	25	30	20	20	25
		15 kW	⁴ 50	60	60	60	⁴ 60	70	30	30	35	25	25	30
		22.5 kW	⁴ 70	80	⁴ 80	90	⁴ 80	90	40	40	45	35	35	35
		30 kW	⁴ 90	100	⁴ 100	110	⁴ 100	125	50	60	60	40	45	45
		45 kW	150	150	150	150	⁴ 150	175	80	80	80	60	60	70
³ Minimum Circuit Ampacity	Unit+ Electric Heat and (1) 0.33 HP Power Exhaust	7.5 kW	40	40	43	43	50	50	22	23	26	17	19	21
		15 kW	49	55	53	59	60	66	27	29	33	22	23	26
		22.5 kW	69	78	72	81	80	89	39	40	44	31	32	35
		30 kW	88	100	92	104	100	112	50	52	55	40	41	44
		45 kW	127	145	131	149	139	157	72	74	78	58	60	62
² Maximum Overcurrent Protection	Unit+ Electric Heat and (1) 0.33 HP Power Exhaust	7.5 kW	50	50	50	50	60	60	25	30	30	20	20	25
		15 kW	60	60	⁴ 60	70	70	70	30	35	35	25	25	30
		22.5 kW	⁴ 80	90	⁴ 80	90	⁴ 90	100	40	45	45	35	35	40
		30 kW	⁴ 100	110	⁴ 100	110	⁴ 110	125	60	60	60	45	45	45
		45 kW	150	150	⁴ 150	175	⁴ 150	175	80	80	80	60	70	70
³ Minimum Circuit Ampacity	Unit+ Electric Heat and (1) 0.33 HP Power Exhaust	7.5 kW	42	42	45	45	52	52	23	24	27	18	20	22
		15 kW	52	58	56	62	63	69	29	31	34	23	25	27
		22.5 kW	72	81	75	84	83	92	40	42	45	32	34	36
		30 kW	91	103	95	107	103	115	51	53	57	41	43	45
		45 kW	130	148	134	152	142	160	74	76	79	59	61	64

ELECTRICAL ACCESSORIES

Disconnect	7.5 kW	54W56			54W56			54W56		
	15 kW	54W56			54W56			54W56		
	22.5 kW	54W56			54W56			54W56		
	30 kW	54W57			54W56			54W56		
	45 kW	54W57			54W56			54W56		

NOTE - All units have a minimum Short Circuit Current Rating (SCCR) of 5000 amps.

¹ Extremes of operating range are plus and minus 10% of line voltage.

² HACR type breaker or fuse.

³ Refer to National or Canadian Electrical Code manual to determine wire, fuse and disconnect size requirements.

ELECTRICAL/ELECTRIC HEAT DATA

8.5 TON

8.5 TON HIGH EFFICIENCY (R-410A)

KCA102H4

¹ Voltage - 60hz		208/230V - 3 Ph			460V - 3 Ph			575V - 3 Ph		
Compressor 1	Rated Load Amps	11			5.5			4.7		
	Locked Rotor Amps	86			37			34		
Compressor 2	Rated Load Amps	11			5.5			4.7		
	Locked Rotor Amps	86			37			34		
Outdoor Fan Motors (2)	Full Load Amps (total)	2.4 (4.8)			1.3 (2.6)			1 (2)		
Power Exhaust (1) 0.33 HP	Full Load Amps	2.4			1.3			1		
Service Outlet 115V GFI (amps)		15			15			20		
Indoor Blower Motor	Horsepower	2	3	5	2	3	5	2	3	5
	Full Load Amps	7.5	10.6	16.7	3.4	4.8	7.6	2.7	3.9	6.1
² Maximum Overcurrent Protection	Unit Only	45	50	60	20	25	30	20	20	25
	With (1) 0.33 HP Power Exhaust	50	50	60	25	25	30	20	20	25
³ Minimum Circuit Ampacity	Unit Only	38	41	48	19	20	24	16	17	20
	With (1) 0.33 HP Power Exhaust	40	43	51	20	22	25	17	18	21

ELECTRIC HEAT DATA

Electric Heat Voltage			208V	240V	208V	240V	208V	240V	480V	480V	480V	600V	600V	600V
² Maximum Overcurrent Protection	Unit+ Electric Heat	7.5 kW	45	45	50	50	60	60	20	25	30	20	20	25
	and (1) 0.33 HP Power Exhaust	15 kW	50	60	60	60	60	70	30	30	35	25	25	30
		22.5 kW	70	80	80	90	80	90	40	40	45	35	35	35
		30 kW	90	100	100	110	100	125	50	60	60	40	45	45
³ Minimum Circuit Ampacity	Unit+ Electric Heat	7.5 kW	38	38	41	41	48	48	19	20	24	16	17	20
	and (1) 0.33 HP Power Exhaust	15 kW	49	55	53	59	60	66	27	29	33	22	23	26
		22.5 kW	69	78	72	81	80	89	39	40	44	31	32	35
		30 kW	88	100	92	104	100	112	50	52	55	40	41	44
² Maximum Overcurrent Protection	Unit+ Electric Heat	7.5 kW	50	50	50	50	60	60	25	25	30	20	20	25
	and (1) 0.33 HP Power Exhaust	15 kW	60	60	60	70	70	70	30	35	35	25	25	30
		22.5 kW	80	90	80	90	90	100	40	45	45	35	35	40
		30 kW	100	110	100	110	110	125	60	60	60	45	45	45
³ Minimum Circuit Ampacity	Unit+ Electric Heat	7.5 kW	40	40	43	43	51	51	20	22	25	17	18	21
	and (1) 0.33 HP Power Exhaust	15 kW	52	58	56	62	63	69	29	31	34	23	25	27
		22.5 kW	72	81	75	84	83	92	40	42	45	32	34	36
		30 kW	91	103	95	107	103	115	51	53	57	41	43	45
Power Exhaust	45 kW	130	148	134	152	142	160	74	76	79	59	61	64	

ELECTRICAL ACCESSORIES

Disconnect	7.5 kW	54W56			54W56		
	15 kW	54W56			54W56		
	22.5 kW	54W56	54W57		54W56		
	30 kW	54W57			54W56		
	45 kW	54W57			54W56		

NOTE - All units have a minimum Short Circuit Current Rating (SCCR) of 5000 amps.

¹ Extremes of operating range are plus and minus 10% of line voltage.

² HACR type breaker or fuse.

³ Refer to National or Canadian Electrical Code manual to determine wire, fuse and disconnect size requirements.

ELECTRICAL/ELECTRIC HEAT DATA

10 TON

10 TON STANDARD EFFICIENCY (R-410A)

KCB120S4

¹ Voltage - 60hz		208/230V - 3 Ph			460V - 3 Ph			575V - 3 Ph		
Compressor 1	Rated Load Amps	13.5			8			5		
	Locked Rotor Amps	109			59			40		
Compressor 2	Rated Load Amps	13.5			8			5		
	Locked Rotor Amps	109			59			40		
Outdoor Fan Motors (2)	Full Load Amps	2.4			1.3			1		
	(total)	(4.8)			(2.6)			(2)		
Power Exhaust (1) 0.33 HP	Full Load Amps	2.4			1.3			1		
Service Outlet 115V GFI (amps)		15			15			20		
Indoor Blower Motor	Horsepower	2	3	5	2	3	5	2	3	5
	Full Load Amps	7.5	10.6	16.7	3.4	4.8	7.6	2.7	3.9	6.1
² Maximum Overcurrent Protection	Unit Only	50	50	60	30	30	35	20	20	25
	With (1) 0.33 HP Power Exhaust	50	60	70	30	30	35	20	20	25
³ Minimum Circuit Ampacity	Unit Only	43	46	53	24	26	29	16	18	20
	With (1) 0.33 HP Power Exhaust	46	49	56	26	27	30	17	19	21

ELECTRIC HEAT DATA

Electric Heat Voltage			208V	240V	208V	240V	208V	240V	480V	480V	480V	600V	600V	600V
² Maximum Overcurrent Protection	Unit+	15 kW	50	60	60	60	60	70	30	30	35	25	25	30
	Electric Heat and (1) 0.33 HP Power Exhaust	22.5 kW	70	80	80	90	80	90	40	40	45	35	35	35
		30 kW	90	100	100	110	100	125	50	60	60	40	45	45
		45 kW	150	150	150	150	150	175	80	80	80	60	60	70
		60 kW	150	175	150	175	150	175	80	80	90	70	70	70
³ Minimum Circuit Ampacity	Unit+	15 kW	49	55	53	59	60	66	27	29	33	22	23	26
	Electric Heat and (1) 0.33 HP Power Exhaust	22.5 kW	69	78	72	81	80	89	39	40	44	31	32	35
		30 kW	88	100	92	104	100	112	50	52	55	40	41	44
		45 kW	127	145	131	149	139	157	72	74	78	58	60	62
		60 kW	135	154	139	158	146	166	77	79	82	62	63	66
² Maximum Overcurrent Protection	Unit+	15 kW	60	60	60	70	70	70	30	35	35	25	25	30
	Electric Heat and (1) 0.33 HP Power Exhaust	22.5 kW	80	90	80	90	90	100	40	45	45	35	35	40
		30 kW	100	110	100	110	110	125	60	60	60	45	45	45
		45 kW	150	150	150	175	150	175	80	80	80	60	70	70
		60 kW	150	175	150	175	150	175	80	80	90	70	70	70
³ Minimum Circuit Ampacity	Unit+	15 kW	52	58	56	62	63	69	29	31	34	23	25	27
	Electric Heat and (1) 0.33 HP Power Exhaust	22.5 kW	72	81	75	84	83	92	40	42	45	32	34	36
		30 kW	91	103	95	107	103	115	51	53	57	41	43	45
		45 kW	130	148	134	152	142	160	74	76	79	59	61	64
		60 kW	138	157	142	161	149	169	79	80	84	63	64	67

ELECTRICAL ACCESSORIES

Disconnect	15 kW	54W56			54W56			54W56		
	22.5 kW	54W57			54W56			54W56		
	30 kW	54W57			54W56			54W56		
	45 kW	54W57			54W56			54W56		
	60 kW	Not Available			54W56			54W56		

NOTE - All units have a minimum Short Circuit Current Rating (SCCR) of 5000 amps.

¹ Extremes of operating range are plus and minus 10% of line voltage.

² HACR type breaker or fuse.

³ Refer to National or Canadian Electrical Code manual to determine wire, fuse and disconnect size requirements.

ELECTRICAL/ELECTRIC HEAT DATA

10 TON

10 TON HIGH EFFICIENCY (R-410A)

KCA120H4

¹ Voltage - 60hz		208/230V - 3 Ph			460V - 3 Ph			575V - 3 Ph		
Compressor 1	Rated Load Amps	13.5			8			5		
	Locked Rotor Amps	109			59			40		
Compressor 2	Rated Load Amps	13.5			8			5		
	Locked Rotor Amps	109			59			40		
Outdoor Fan Motors (2)	Full Load Amps	2.4			1.3			1		
	(total)	(4.8)			(2.6)			(2)		
Power Exhaust (1) 0.33 HP	Full Load Amps	2.4			1.3			1		
Service Outlet 115V GFI (amps)		15			15			20		
Indoor Blower Motor	Horsepower	2	3	5	2	3	5	2	3	5
	Full Load Amps	7.5	10.6	16.7	3.4	4.8	7.6	2.7	3.9	6.1
² Maximum	Unit Only	50	50	60	30	30	35	20	20	25
Overcurrent Protection	With (1) 0.33 HP	50	60	70	30	30	35	20	20	25
	Power Exhaust									
³ Minimum	Unit Only	43	46	53	24	26	29	16	18	20
Circuit Ampacity	With (1) 0.33 HP	46	49	56	26	27	30	17	19	21
	Power Exhaust									

ELECTRIC HEAT DATA

Electric Heat Voltage			208V	240V	208V	240V	208V	240V	480V	480V	480V	600V	600V	600V
² Maximum	Unit+ Electric Heat Protection	15 kW	50	60	60	60	60	70	30	30	35	25	25	30
		22.5 kW	70	80	80	90	80	90	40	40	45	35	35	35
		30 kW	90	100	100	110	100	125	50	60	60	40	45	45
		45 kW	150	150	150	150	150	175	80	80	80	60	60	70
		60 kW	150	175	150	175	150	175	80	80	90	70	70	70
³ Minimum	Unit+ Electric Heat Protection	15 kW	49	55	53	59	60	66	27	29	33	22	23	26
		22.5 kW	69	78	72	81	80	89	39	40	44	31	32	35
		30 kW	88	100	92	104	100	112	50	52	55	40	41	44
		45 kW	127	145	131	149	139	157	72	74	78	58	60	62
		60 kW	135	154	139	158	146	166	77	79	82	62	63	66
² Maximum	Unit+ Electric Heat Protection and (1) 0.33 HP	15 kW	60	60	60	70	70	70	30	35	35	25	25	30
		22.5 kW	80	90	80	90	90	100	40	45	45	35	35	40
		30 kW	100	110	100	110	110	125	60	60	60	45	45	45
		45 kW	150	150	150	175	150	175	80	80	80	60	70	70
		60 kW	150	175	150	175	150	175	80	80	90	70	70	70
³ Minimum	Unit+ Electric Heat Protection and (1) 0.33 HP	15 kW	52	58	56	62	63	69	29	31	34	23	25	27
		22.5 kW	72	81	75	84	83	92	40	42	45	32	34	36
		30 kW	91	103	95	107	103	115	51	53	57	41	43	45
		45 kW	130	148	134	152	142	160	74	76	79	59	61	64
		60 kW	138	157	142	161	149	169	79	80	84	63	64	67

ELECTRICAL ACCESSORIES

Disconnect	15 kW	54W56			54W56		
	22.5 kW	54W56	54W57		54W56		
	30 kW	54W57			54W56		
	45 kW	54W57			54W56		
	60 kW	Not Available			54W56	N/A	54W56

NOTE - All units have a minimum Short Circuit Current Rating (SCCR) of 5000 amps.

¹ Extremes of operating range are plus and minus 10% of line voltage.

² HACR type breaker or fuse.

³ Refer to National or Canadian Electrical Code manual to determine wire, fuse and disconnect size requirements.

ELECTRICAL/ELECTRIC HEAT DATA

12.5 TON

12.5 TON STANDARD EFFICIENCY (R-410A)

KCB150S4

¹ Voltage - 60hz		208/230V - 3 Ph			460V - 3 Ph			575V - 3 Ph		
Compressor 1	Rated Load Amps	19.6			8.2			6.6		
	Locked Rotor Amps	136			66.1			55.3		
Compressor 2	Rated Load Amps	22.4			10.6			7.7		
	Locked Rotor Amps	149			75.0			54.0		
Outdoor Fan Motors (2)	Full Load Amps	3			1.5			1.2		
	(total)	(6)			(3)			(2.4)		
Power Exhaust (1) 0.33 HP	Full Load Amps	2.4			1.3			1		
Service Outlet 115V GFI (amps)		15			15			20		
Indoor Blower Motor	Horsepower	2	3	5	2	3	5	2	3	5
	Full Load Amps	7.5	10.6	16.7	3.4	4.8	7.6	2.7	3.9	6.1
² Maximum Overcurrent Protection	Unit Only	80	80	90	35	35	40	25	30	30
	With (1) 0.33 HP Power Exhaust	80	80	90	35	40	40	30	30	30
³ Minimum Circuit Ampacity	Unit Only	62	65	71	28	30	33	22	23	25
	With (1) 0.33 HP Power Exhaust	64	67	73	30	31	34	23	24	26

ELECTRIC HEAT DATA

Electric Heat Voltage			208V	240V	208V	240V	208V	240V	480V	480V	480V	600V	600V	600V
² Maximum Overcurrent Protection	Unit+ Electric Heat and (1) 0.33 HP Power Exhaust	15 kW	70	70	80	80	80	80	30	30	35	25	25	30
		22.5 kW	70	80	80	90	80	90	40	40	45	35	35	35
		30 kW	90	100	100	110	100	125	50	60	60	40	45	45
		45 kW	150	150	150	150	150	175	80	80	80	60	60	70
		60 kW	150	175	150	175	150	175	80	80	90	70	70	70
³ Minimum Circuit Ampacity	Unit+ Electric Heat and (1) 0.33 HP Power Exhaust	15 kW	58	58	61	61	67	67	27	29	33	22	23	26
		22.5 kW	69	78	72	81	80	89	39	40	44	31	32	35
		30 kW	88	100	92	104	100	112	50	52	55	40	41	44
		45 kW	127	145	131	149	139	157	72	74	78	58	60	62
		60 kW	135	154	139	158	146	166	77	79	82	62	63	66
² Maximum Overcurrent Protection	Unit+ Electric Heat and (1) 0.33 HP Power Exhaust	15 kW	70	70	80	80	80	80	30	35	35	25	25	30
		22.5 kW	80	90	80	90	90	100	40	45	45	35	35	40
		30 kW	100	110	100	110	110	125	60	60	60	45	45	45
		45 kW	150	150	150	175	150	175	80	80	80	60	70	70
		60 kW	150	175	150	175	150	175	80	80	90	70	70	70
³ Minimum Circuit Ampacity	Unit+ Electric Heat and (1) 0.33 HP Power Exhaust	15 kW	60	60	64	64	70	70	29	31	34	23	25	27
		22.5 kW	72	81	75	84	83	92	40	42	45	32	34	36
		30 kW	91	103	95	107	103	115	51	53	57	41	43	45
		45 kW	130	148	134	152	142	160	74	76	79	59	61	64
		60 kW	138	157	142	161	149	169	79	80	84	63	64	67

ELECTRICAL ACCESSORIES

Disconnect	15 kW	54W56			54W56			54W56		
	22.5 kW	54W57			54W56			54W56		
	30 kW	54W57			54W56			54W56		
	45 kW	Not Available			54W56			54W56		
	60 kW	Not Available			54W56			54W56		

NOTE - All units have a minimum Short Circuit Current Rating (SCCR) of 5000 amps.

¹ Extremes of operating range are plus and minus 10% of line voltage.

² HACR type breaker or fuse.

³ Refer to National or Canadian Electrical Code manual to determine wire, fuse and disconnect size requirements.

ELECTRIC HEAT CAPACITIES

Volts Input	7.5 kW			15 kW			22.5 kW			30 kW			45 kW			60 kW		
	kW Input	Btuh Output	No. of Stages	kW Input	Btuh Output	No. of Stages	kW Input	Btuh Output	No. of Stages	kW Input	Btuh Output	No. of Stages	kW Input	Btuh Output	No. of Stages	kW Input	Btuh Output	No. of Stages
208	5.6	19,100	1	11.3	38,600	1	16.9	57,700	2	22.5	76,800	2	33.8	115,300	2	45.0	153,600	2
220	6.3	21,500	1	12.6	43,000	1	18.9	64,500	2	25.2	86,000	2	37.8	129,000	2	50.4	172,000	2
230	6.9	23,600	1	13.8	47,100	1	20.7	70,700	2	27.5	93,900	2	41.3	141,000	2	55.1	188,000	2
240	7.5	25,600	1	15.0	51,200	1	22.5	76,800	2	30.0	102,400	2	45.0	153,600	2	60.0	204,800	2
440	6.9	21,500	1	12.6	43,000	1	18.9	64,500	2	25.2	86,000	2	37.8	129,000	2	50.4	172,000	2
460	6.9	23,600	1	13.8	47,100	1	20.7	70,700	2	27.5	93,900	2	41.3	141,000	2	55.1	188,000	2
480	7.5	25,600	1	15.0	51,200	1	22.5	76,800	2	30.0	102,400	2	45.0	153,600	2	60.0	204,800	2
550	6.3	21,500	1	12.6	43,000	1	18.9	64,500	2	25.2	86,000	2	37.8	129,000	2	50.4	172,000	2
575	6.9	23,600	1	13.8	47,100	1	20.7	70,700	2	27.5	93,900	2	41.3	141,000	2	55.1	188,000	2
600	7.5	25,600	1	15.0	51,200	1	22.5	76,800	2	30.0	102,400	2	45.0	153,600	2	60.0	204,800	2

UNIT CLEARANCES

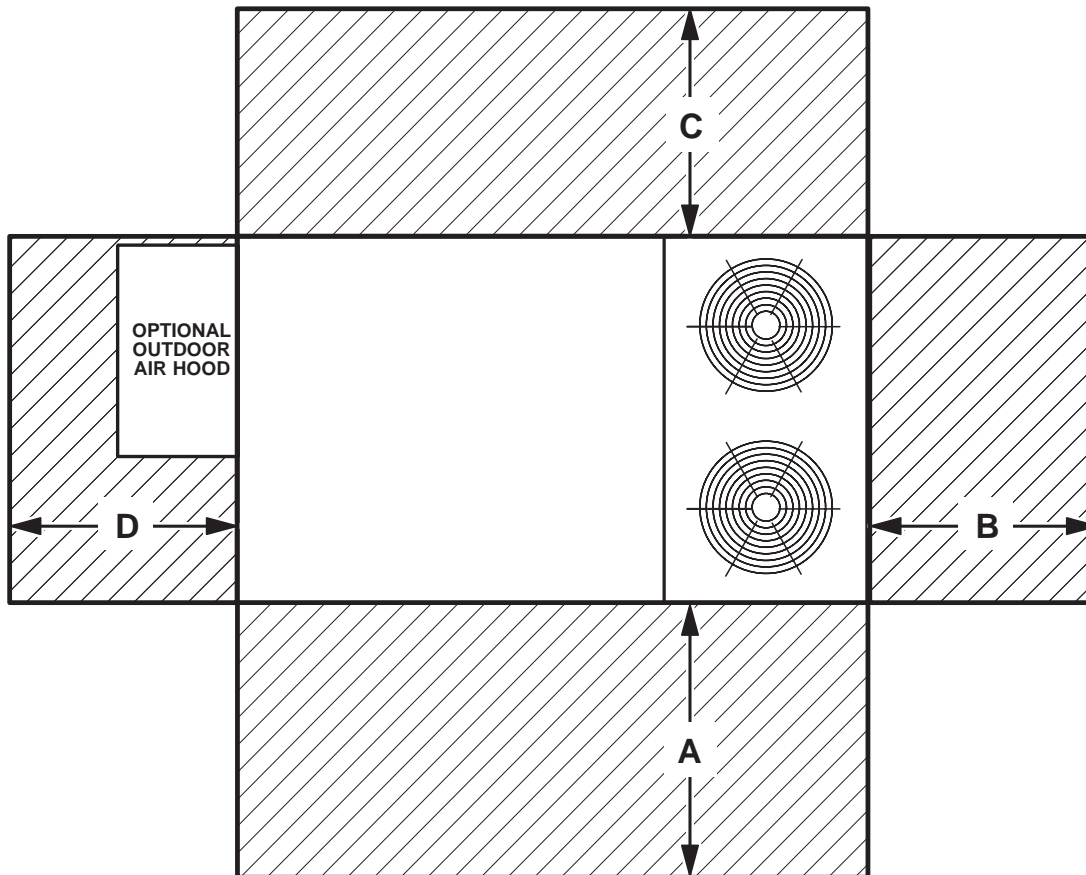



¹ Unit Clearance	A		B		C		D		Top Clearance
	in.	mm	in.	mm	in.	mm	in.	mm	
Service Clearance	60	1524	36	914	36	914	60	1524	Unobstructed
Minimum Operation Clearance	36	914	36	914	36	914	36	914	

NOTE - Entire perimeter of unit base requires support when elevated above the mounting surface.

¹ Service Clearance - Required for removal of serviceable parts.

Minimum Operation Clearance - Required clearance for proper unit operation.

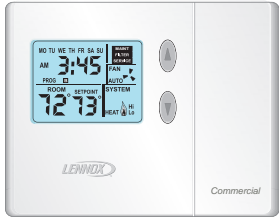
OPTIONAL CONVENTIONAL TEMPERATURE CONTROL SYSTEMS

Item		Model No.	Catalog No.
COMFORTSENSE® 7500 COMMERCIAL 7-DAY PROGRAMMABLE THERMOSTAT			
 <ul style="list-style-type: none"> • Four-Stage Heating / Two-Stage Cooling Universal Multi-Stage • Intuitive Touchscreen Interface • Remote Indoor Temperature Sensing with Averaging • Outside or Discharge Air Temperature Display • Full Seven-Day Programming • Four Time Periods Per Day • Temperature and Humidity Control • One-Touch Away Mode • Holiday Scheduling • Smooth Setback Recovery (SSR) • Performance Reports • Notifications/Reminders • Dehumidification/Humiditrol® Control for Split Systems and Rooftop Units • Economizer Relay Control • Backlit Display • Wallplate Furnished • FDD, ASHRAE, and IECC Compliant 		C0STAT06FF2L	17G74
Optional Accessories	¹ Remote non-adjustable wall mount 20k temperature sensor	C0SNZN01AE2-	47W36
	¹ Remote non-adjustable wall mount 10k temperature sensor	C0SNZN73AE1-	47W37
	Remote non-adjustable discharge air (duct mount) temperature sensor	C0SNDC00AE1-	19L22
	Outdoor temperature sensor	C0SNSR03AE1-	X2658
	Locking cover (clear)	C0MISC15AE1-	39P21
¹ Remote sensors can be applied in any of the following combinations: One Sensor - (1) 47W36 Two Sensors - (2) 47W37 Three Sensors - (2) 47W36 and (1) 47W37 Four Sensors - (4) 47W36 Five Sensors - (3) 47W36 and (2) 47W37			
COMFORTSENSE® 3000 COMMERCIAL 5-2 DAY PROGRAMMABLE THERMOSTAT			
 <ul style="list-style-type: none"> • Two-Stage Heating / Two-Stage Cooling Conventional Systems • Intuitive Interface • 5-2 Day Programming • Program Hold • Remote Indoor Temperature Sensing • Smooth Setback Recovery (SSR) • Economizer Relay Control • Maintenance/Filter/Service Reminders • Backlit Display • Wallplate Furnished • Simple Up and Down Temperature Control. 		C0STAT05FF1L	11Y05
Optional Accessories	Remote non-adjustable wall mount 10k averaging temperature sensor	C0SNZN73AE1-	47W37
	Optional wall mounting plate	C0MISC17AE1-	X2659
7-DAY PROGRAMMABLE THERMOSTAT - BACNET COMPATIBLE WITH REHEAT FUNCTION			
 <ul style="list-style-type: none"> • For units with or without ¹ Humiditrol® • BTL listed MS/TP ensures compatibility with any BACnet system • Built-in control programs for conventional and heat pump applications • Conventional systems up to 3-stage heat and 3-stage cool • Heat pumps with 1 or 2 compressors and up to 2-stage auxiliary heat • On-board temperature and humidity sensor • Multiple configurable inputs and outputs enable advanced control strategies • Set-up Wizard enables rapid system configuration • No special tools required for installation or commissioning • Seven-day (2, 4 or 6 event) occupancy scheduling per day • Backlit 5-inch LCD touchscreen 		- - -	Y8241
¹ BACnet Thermostat (Y8241) will control units with and without the Humiditrol® option. If there is a mix of units equipped with and without Humiditrol on the same site, this thermostat can be used for all units if desired.			
BACnet Controls (no reheat capability)	BACnet® Module (factory or field installed)	K0CTRL31B-2	16X71
	BACnet® Room Sensor with Display (field installed)	K0SNSR01FF1	97W23
	BACnet® Room Sensor without Display (field installed)	K0SNSR00FF1	97W24
Optional Accessories	Plenum Cable (RJ45/CAT5 75 ft.)	K0MISC00FF1	97W25

WEIGHT DATA

Model Number	Outdoor Coil	Net		Shipping		Outdoor Coil	Net		Shipping	
		lbs.	kg	lbs.	kg		lbs.	kg	lbs.	kg
092H Base Unit	Environ™	1052	477	1137	516	---	---	---	---	---
092H Max. Unit	Environ™	1209	548	1294	587	---	---	---	---	---
102H Base Unit	Environ™	1059	480	1144	519	---	---	---	---	---
102H Max. Unit	Environ™	1216	552	1301	590	---	---	---	---	---
120H Base Unit	Environ™	1094	496	1179	535	---	---	---	---	---
120H Max. Unit	Environ™	1258	571	1343	609	---	---	---	---	---
092S Base Unit	Environ™	870	395	955	433	Fin/Tube	927	421	1012	459
092S Max. Unit	Environ™	1027	466	1112	504	Fin/Tube	1084	492	1169	531
102S Base Unit	Environ™	890	404	975	442	Fin/Tube	947	430	1032	469
102S Max. Unit	Environ™	1047	475	1132	513	Fin/Tube	1104	501	1189	540
120S Base Unit	Environ™	954	432	1039	471	Fin/Tube	1025	465	1110	504
120S Max. Unit	Environ™	1118	507	1203	545	Fin/Tube	1189	540	1274	578
150S Base Unit	---	---	---	---	---	Fin/Tube	1084	492	1169	531
150S Max. Unit	---	---	---	---	---	Fin/Tube	1234	560	1319	599

NOTE - Max. Unit is the unit with ALL INTERNAL OPTIONS Installed. (Economizer, Standard Static Power Exhaust Fans, Controls, etc.). Does not include accessories EXTERNAL to unit.

OPTIONS / ACCESSORIES

Model Number	Shipping Weight		
	lbs.	kg	
ECONOMIZER / OUTDOOR AIR / EXHAUST			
Economizer			
Economizer Dampers	60	27	
Barometric Relief Dampers (downflow)	8	4	
Barometric Relief Damper Hood (downflow)	25	11	
Outdoor Air Hood (downflow)	23	10	
Outdoor Air Dampers			
Outdoor Air Damper Section - Automatic	51	23	
Outdoor Air Damper Section - Manual	39	18	
Power Exhaust	31	14	
ELECTRIC HEAT			
7.5 kW	50	23	
15 kW	50	23	
22.5 kW	57	26	
30 kW	57	26	
45 kW	59	27	
60 kW	68	31	
HUMIDITROL® DEHUMIDIFICATION SYSTEM			
Humiditrol Dehumidification Option	10	5	
MSAV (MULTI-STAGE AIR VOLUME) BLOWER OPTION			
Variable Frequency Drive (VFD) and associated components	10	5	
ROOF CURBS			
Hybrid Roof Curbs, Downflow			
8 in. height	60	27	
14 in. height	85	39	
18 in. height	100	45	
24 in. height	125	57	
Adjustable Pitch Curb, Downflow			
14 in. height	191	82	
CEILING DIFFUSERS			
Step-Down	RTD11-95S	118	54
	RTD11-135S	135	61
	RTD11-185S	168	76
Flush	FD11-95S	118	54
	FD11-135S	135	61
	FD11-185S	168	76
Transitions	C1DIFF30B-1	30	14
	C1DIFF31B-1	32	15
	C1DIFF32B-1	36	16
PACKAGING			
LTL Packaging (less than truck load)	105	48	

DIMENSIONS - UNIT

Model No.	CORNER WEIGHTS												CENTER OF GRAVITY											
	AA				BB				CC				DD				EE				FF			
	Base		Max.		Base		Max.		Base		Max.		Base		Max.		Base		Max.		Base		Max.	
	lbs.	kg	lbs.	kg	lbs.	kg	lbs.	kg	lbs.	kg	lbs.	kg	lbs.	kg	lbs.	kg	in.	mm	in.	mm	in.	mm	in.	mm
092S	223	101	309	141	190	86	259	118	206	94	275	124	250	113	341	154	44-1/2	1130	43-1/2	1105	24-1/2	622	25-1/2	648
092H	270	122	310	141	230	104	265	120	249	113	287	130	302	137	348	158	44-1/2	1130	43-1/2	1105	24-1/2	622	25-1/2	648
102S	228	104	316	143	195	88	262	119	211	96	280	127	254	116	347	157	44-1/2	1130	43-1/2	1105	24-1/2	622	25-1/2	648
102H	272	123	312	141	232	105	266	121	251	114	288	131	304	138	350	159	44-1/2	1130	43-1/2	1105	24-1/2	622	25-1/2	648
120S	243	110	331	150	204	93	273	124	220	100	294	133	271	123	369	167	44	1118	43	1092	24-3/4	629	25-3/4	654
120H	283	128	325	148	238	108	274	124	257	116	295	134	316	143	363	165	44	1118	43	1092	24-3/4	629	25-3/4	654
150S	263	119	305	138	222	101	257	117	242	110	280	127	298	135	346	157	44	1118	43	1092	24	610	25	635

Base Unit - The unit with NO OPTIONS.

Max. Unit - The unit with ALL OPTIONS Installed. (Economizer, etc.)

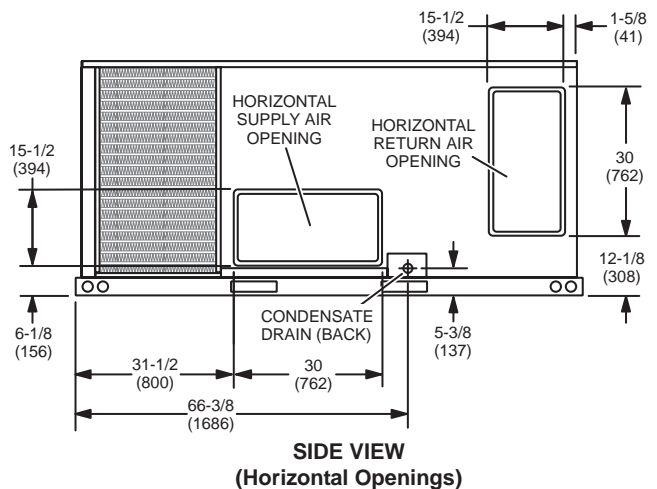
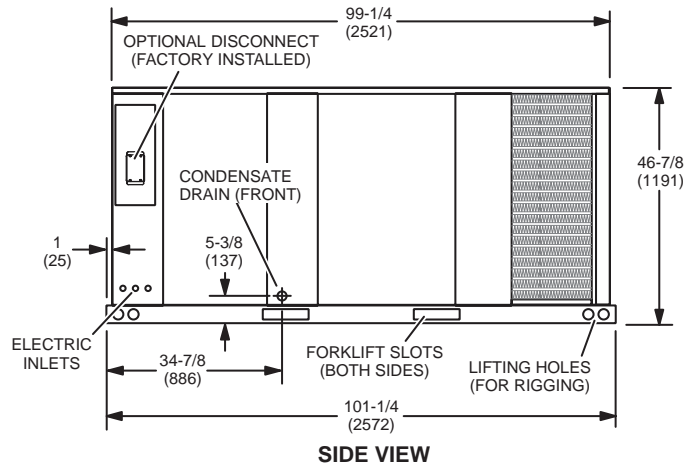
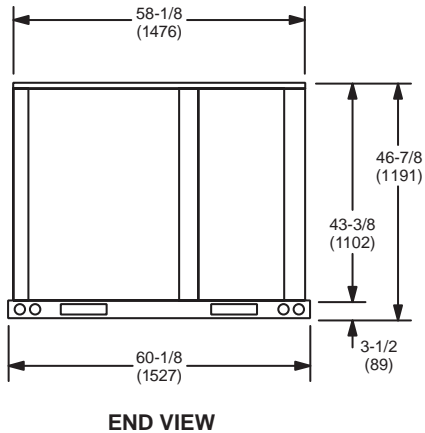
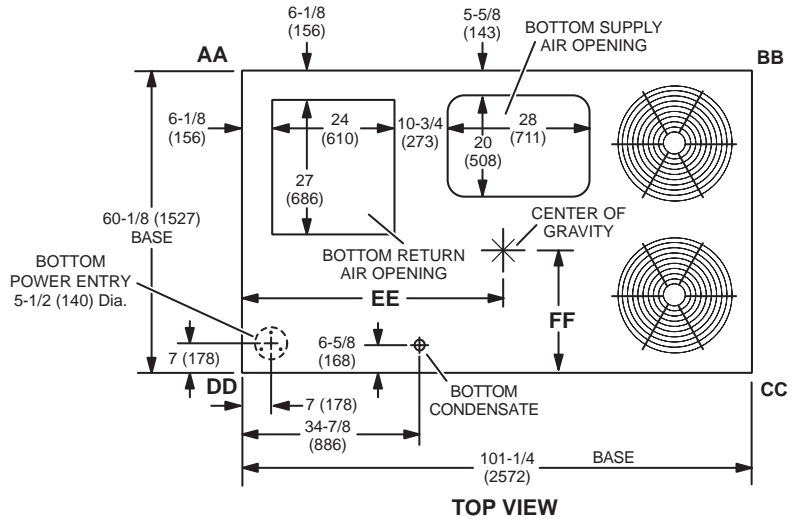

OUTDOOR AIR HOOD DETAIL

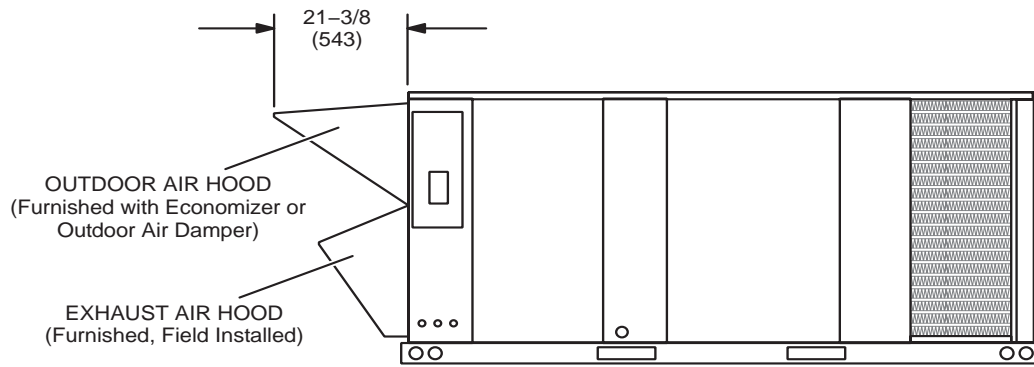

DIMENSIONS - ACCESSORIES

HORIZONTAL ECONOMIZER APPLICATION

(With Furnished Barometric Relief Dampers and Optional Horizontal Discharge Kit - Required)

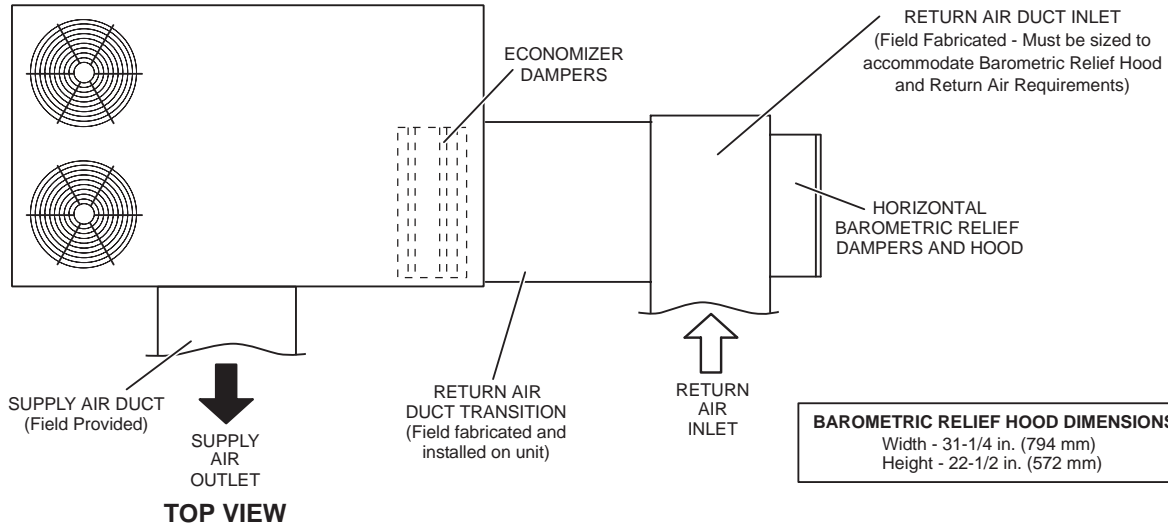

TOP VIEW

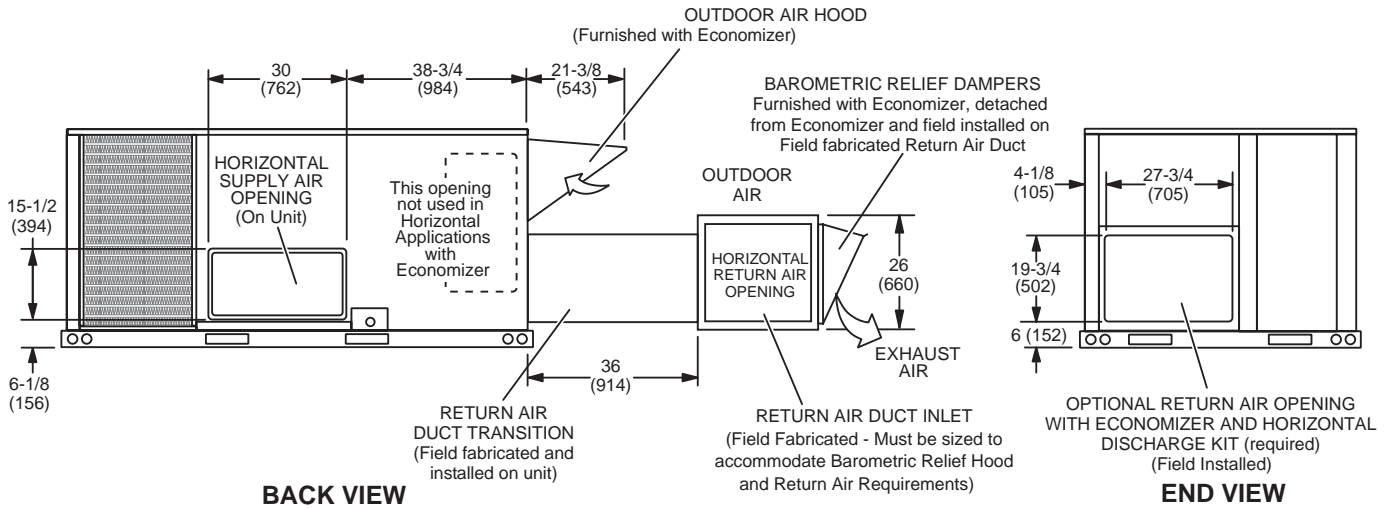

BACK VIEW

END VIEW

NOTE - Return Air Duct and Transition must be supported.

BAROMETRIC RELIEF DAMPERS

(Furnished with Economizer)

(Field installed in horizontal return air duct adjacent to unit)

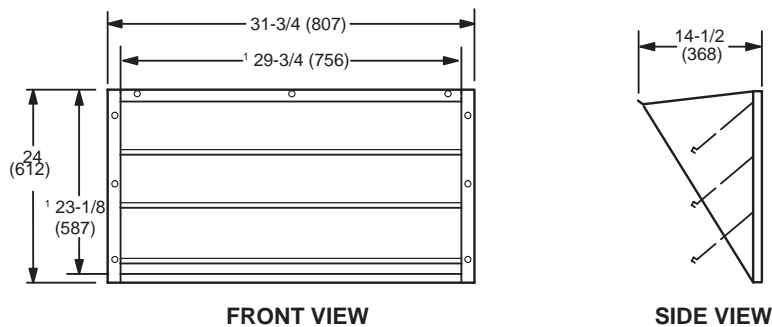

FRONT VIEW

SIDE VIEW

¹ NOTE - Opening size required in return air duct.

DIMENSIONS - ACCESSORIES

HORIZONTAL ECONOMIZER APPLICATION

(with Optional Low Profile Horizontal Barometric Relief Dampers and Horizontal Discharge Kit - Required)

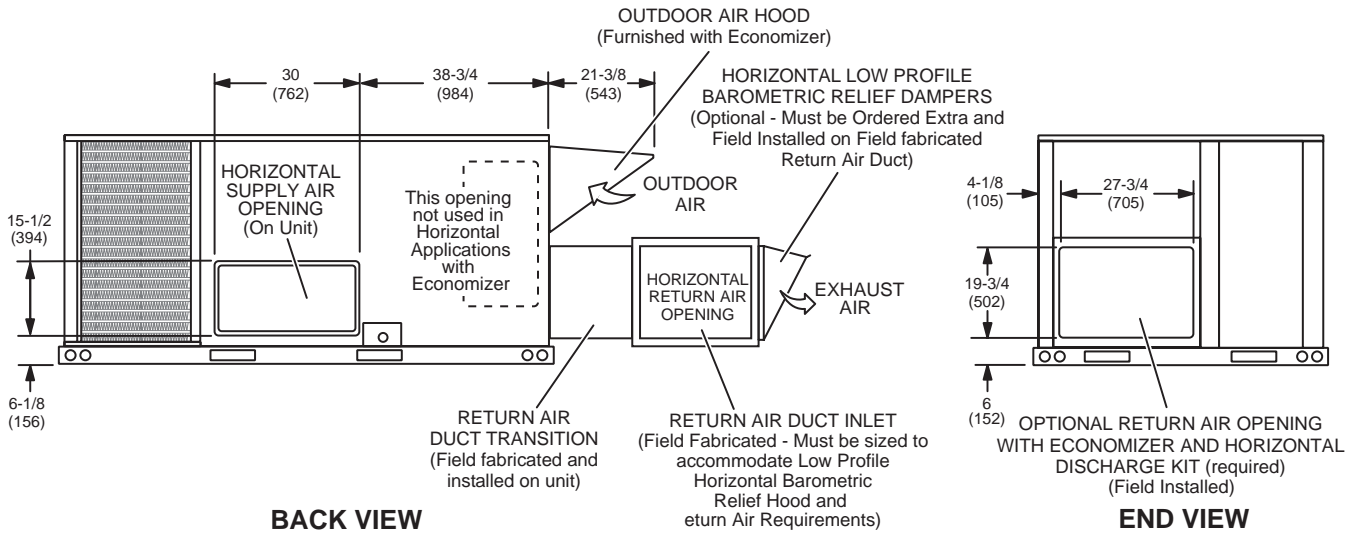
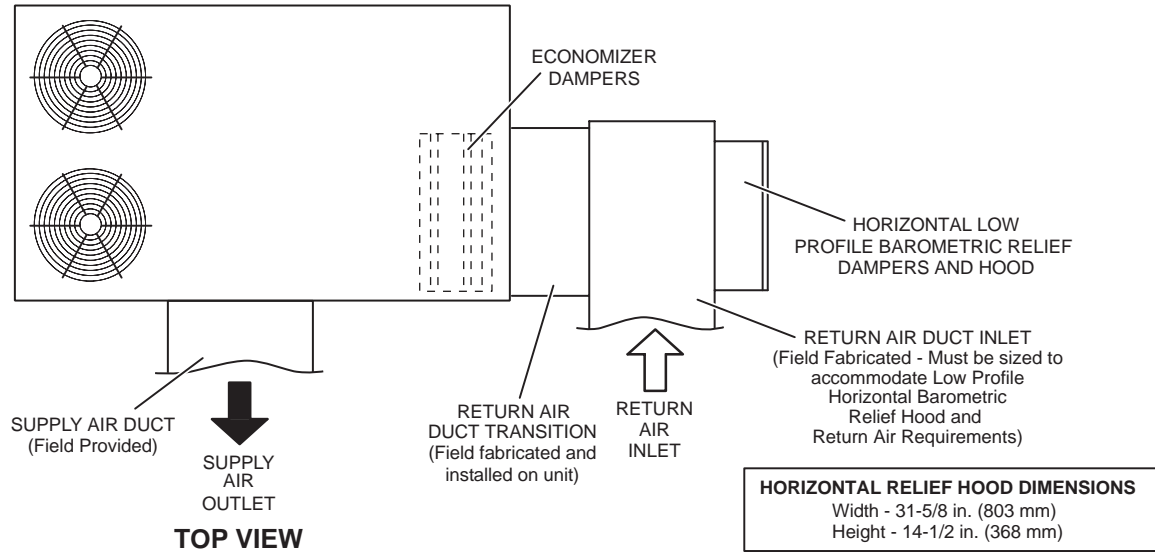

NOTE - Return Air Duct and Transition must be supported.

HORIZONTAL LOW PROFILE BAROMETRIC RELIEF DAMPERS (Field installed in horizontal return air duct adjacent to unit)

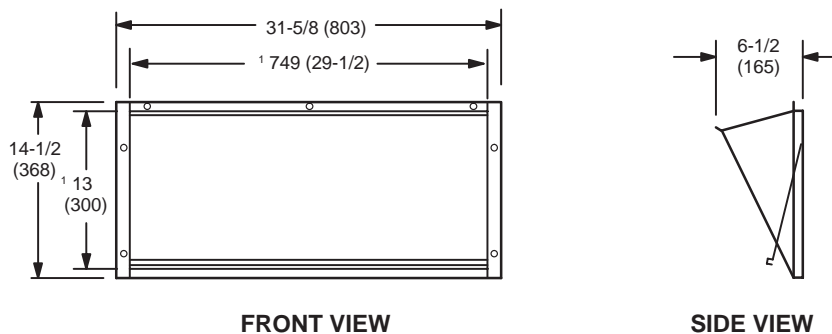

¹ NOTE - Opening size required in return air duct.

DIMENSIONS - ACCESSORIES

HYBRID ROOF CURBS - DOUBLE DUCT OPENING

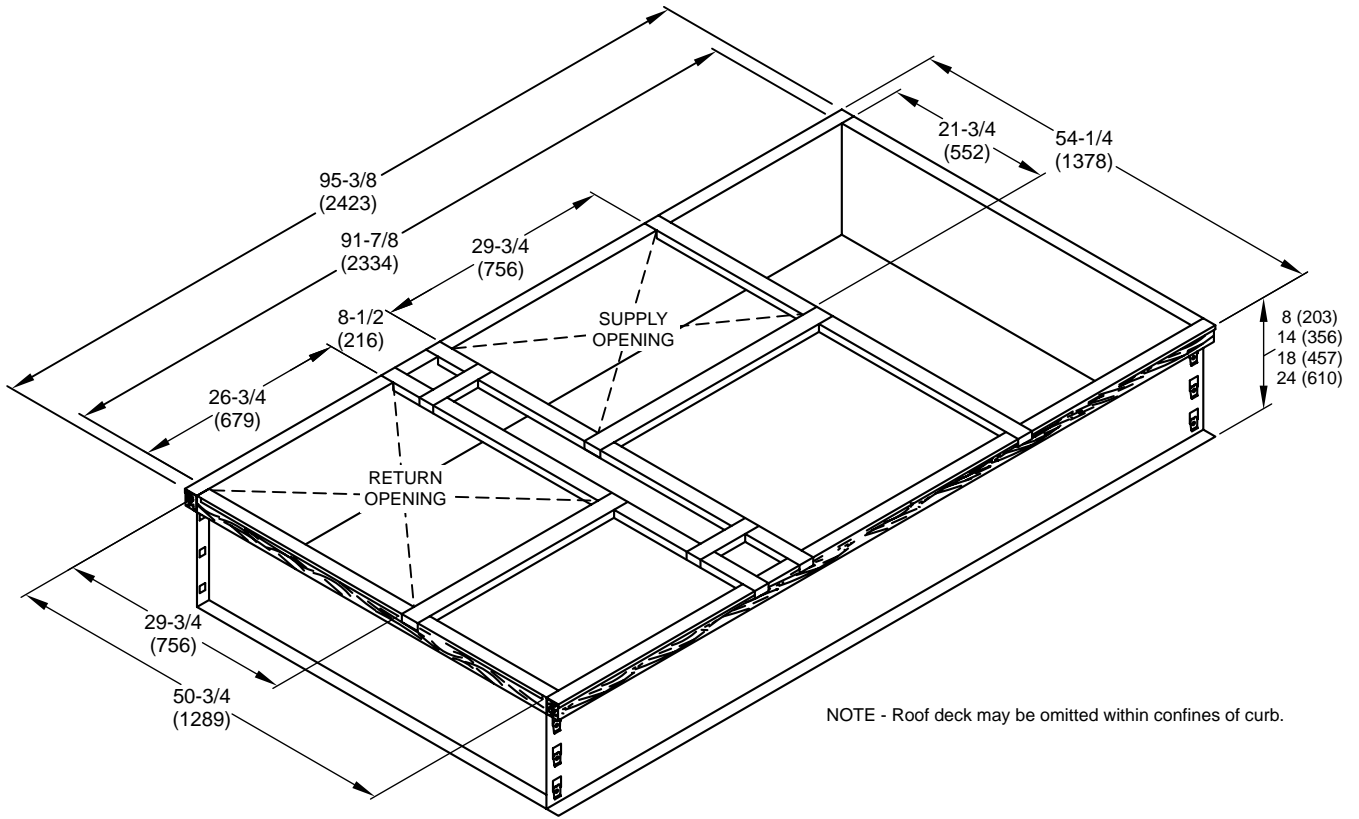

TYPICAL FLASHING DETAIL FOR ROOF CURB

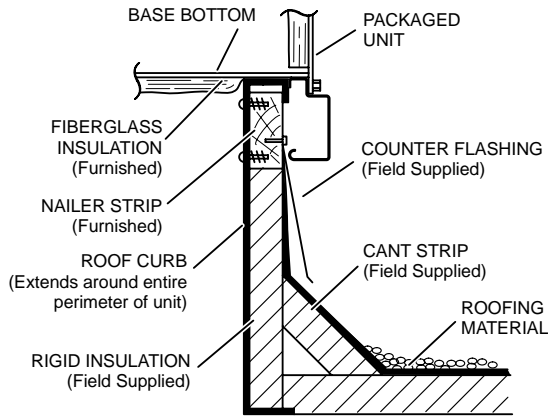

DETAIL ROOF CURB

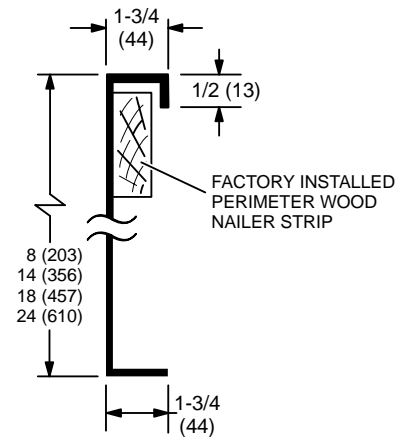

DIMENSIONS - ACCESSORIES

ADJUSTABLE PITCH CURBS - DOUBLE DUCT OPENING

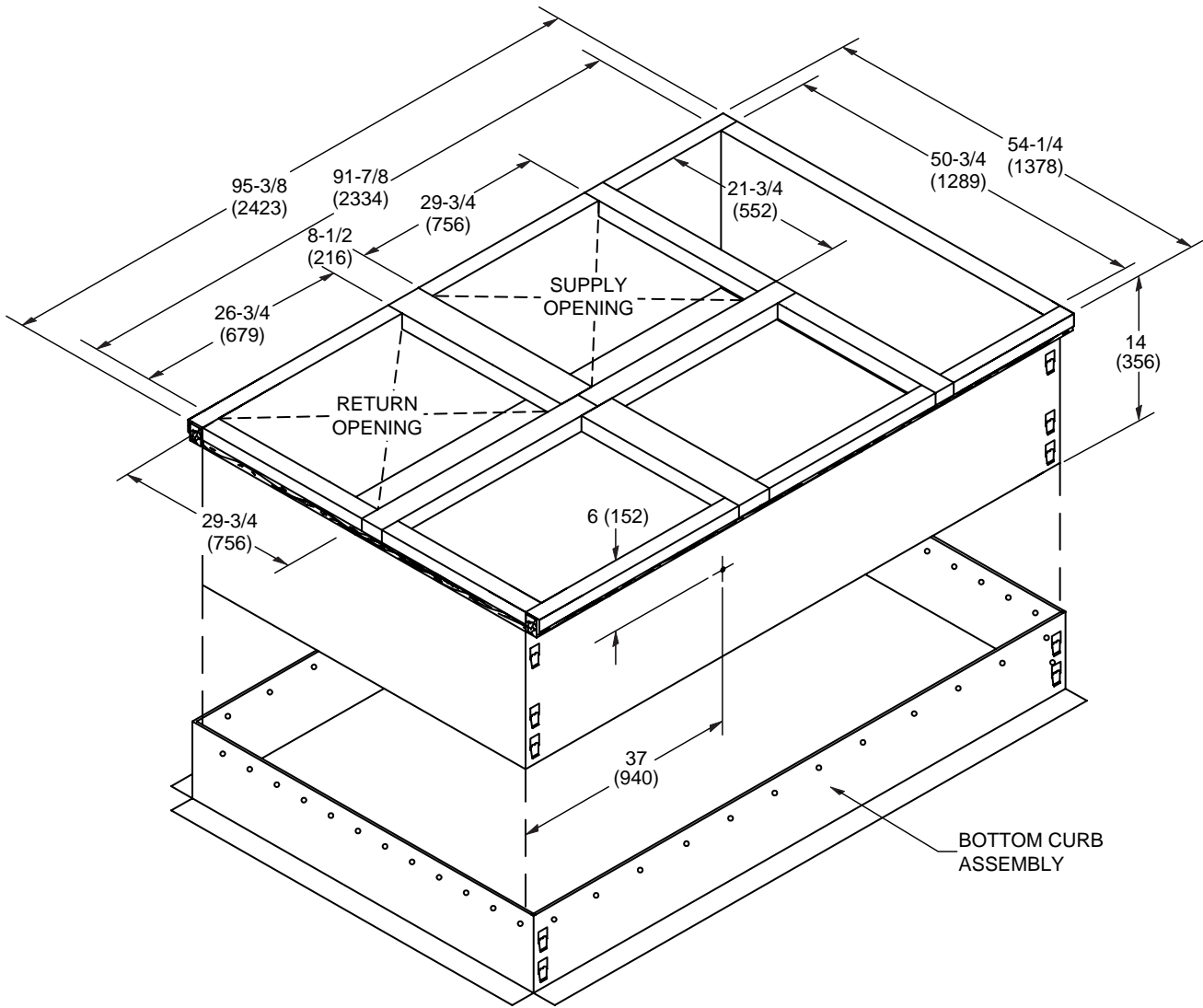

NOTE - Maximum slope pitch is 3/4 in. per 1 foot (19 mm per 305 mm) in any one direction.

TYPICAL FLASHING DETAIL FOR ROOF CURB

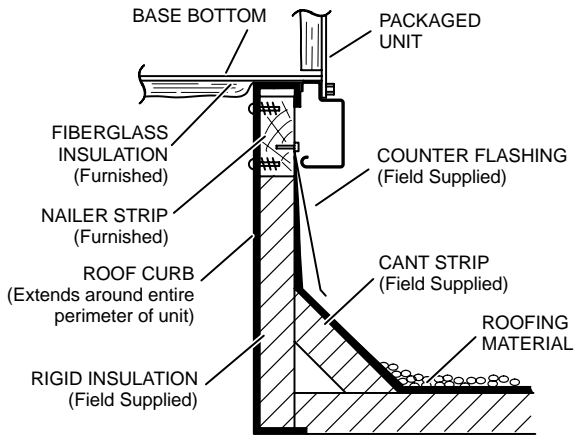

DETAIL ROOF CURB

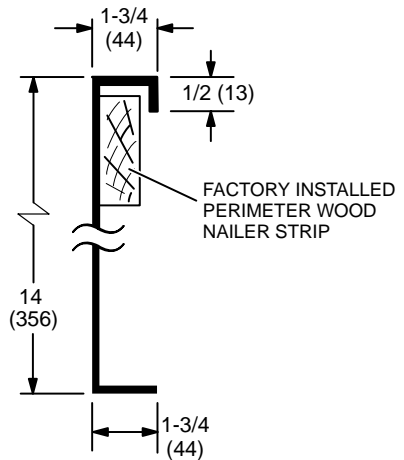

DIMENSIONS - ACCESSORIES

ROOF CURBS WITH SUPPLY & RETURN AIR TRANSITIONS FOR CEILING DIFFUSERS

C1DIFF30B-1 ROUND TRANSITIONS
(for 092 models)

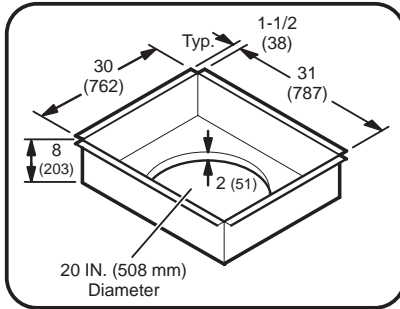

C1DIFF31B-1 & C1DIFF32B-1 RECTANGULAR TRANSITIONS
(for 102 thru 150 models)

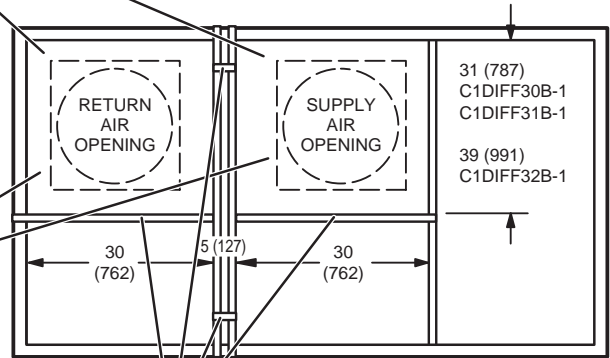
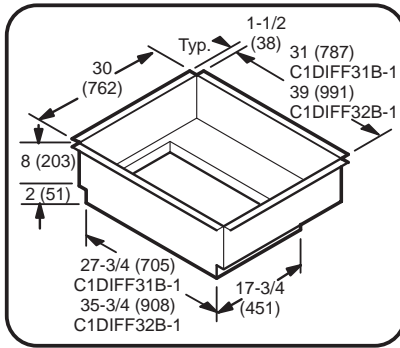

TOP VIEW

NOTE - These four supports are furnished with the transitions to replace supports furnished with curb for proper transition spacing.

DIMENSIONS - ACCESSORIES

COMBINATION CEILING SUPPLY AND RETURN DIFFUSERS

STEP-DOWN CEILING DIFFUSER

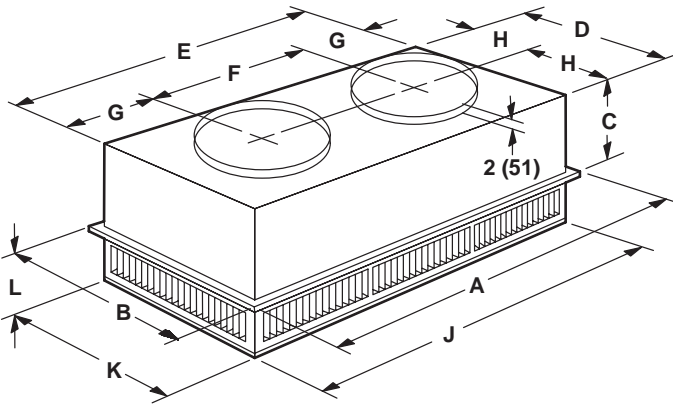

FLUSH CEILING DIFFUSER

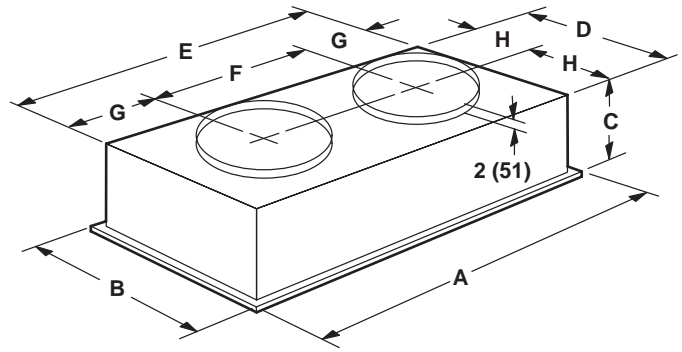

Model Number		RTD11-95S
A	in.	47-5/8
	mm	1159
B	in.	29-5/8
	mm	752
C	in.	14-3/8
	mm	365
D	in.	27-1/2
	mm	699
E	in.	45-1/2
	mm	1158
F	in.	22-1/2
	mm	572
G	in.	11-1/2
	mm	292
H	in.	13-3/4
	mm	349
J	in.	45-1/2
	mm	1156
K	in.	27-1/2
	mm	699
L	in.	8-1/8
	mm	206
Duct Size	in.	20 round
	mm	508 round

Model Number		FD11-95S
A	in.	47-5/8
	mm	1159
B	in.	29-5/8
	mm	752
C	in.	16-5/8
	mm	422
D	in.	27
	mm	686
E	in.	45
	mm	1143
F	in.	22-1/2
	mm	572
G	in.	11-1/4
	mm	286
H	in.	13-1/2
	mm	343
Duct Size	in.	20 round
	mm	508 round

DIMENSIONS - ACCESSORIES

COMBINATION CEILING SUPPLY AND RETURN DIFFUSERS

STEP-DOWN CEILING DIFFUSER

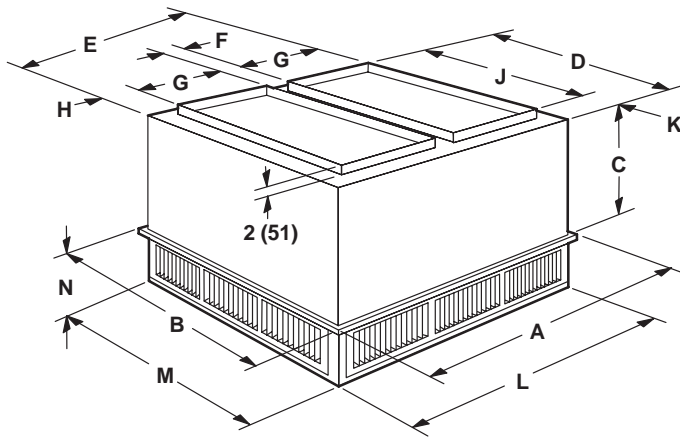

FLUSH CEILING DIFFUSER

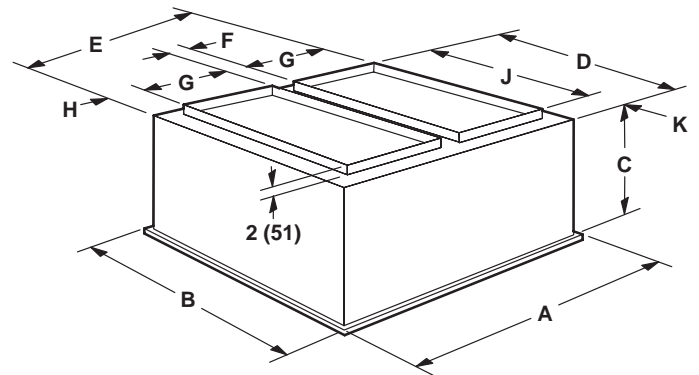

Model Number		RTD11-135S	RTD11-185S
A	in.	47-5/8	47-5/8
	mm	1210	1210
B	in.	35-5/8	47-5/8
	mm	905	1210
C	in.	20-5/8	24-5/8
	mm	524	625
D	in.	33-1/2	45-1/2
	mm	851	1156
E	in.	45-1/2	45-1/2
	mm	1156	1156
F	in.	4-1/2	4-1/2
	mm	114	114
G	in.	18	18
	mm	457	457
H	in.	2-1/2	2-1/2
	mm	64	64
J	in.	28	36
	mm	711	914
K	in.	2-3/4	4-3/4
	mm	70	121
L	in.	45-1/2	45-1/2
	mm	1156	1156
M	in.	33-1/2	45-1/2
	mm	851	1156
N	in.	9-1/8	10-1/8
	mm	232	257
Duct Size	in.	18 x 28	18 x 36
	mm	457 x 711	457 x 914

Model Number		FD11-135S	FD11-185S
A	in.	47-5/8	47-5/8
	mm	1210	1210
B	in.	35-5/8	47-5/8
	mm	905	1210
C	in.	23-1/4	29-1/4
	mm	591	743
D	in.	33	45
	mm	838	1143
E	in.	45	45
	mm	1143	1143
F	in.	4-1/2	4-1/2
	mm	114	114
G	in.	18	18
	mm	457	457
H	in.	2-1/4	2-1/4
	mm	57	57
J	in.	28	36
	mm	711	914
K	in.	2-1/2	4-1/2
	mm	64	114
Duct Size	in.	18 x 28	18 x 36
	mm	457 x 711	457 x 914

REVISIONS

Section	Description
Dehumidification Rating Tables	Corrected Outdoor Air Temperature Entering Outdoor Coil ranges.



Visit us at www.lennox.com

For the latest technical information, www.lennoxcommercial.com

Contact us at 1-800-4-LENNOX

NOTE - Due to Lennox' ongoing commitment to quality, Specifications, Ratings and Dimensions subject to change without notice and without incurring liability. Improper installation, adjustment, alteration, service or maintenance can cause property damage or personal injury. Installation and service must be performed by a qualified installer and servicing agency.

©2019 Lennox Industries, Inc.