



**COMMERCIAL
PRODUCT SPECIFICATIONS**

Bulletin No. 210823
August 2019
Supersedes July 2019



LANDMARK®
Performance Marked by Flexibility™



**ASHRAE 90.1
COMPLIANT**

13 to 25 Tons
Net Cooling Capacity - 150,000 to 270,000 Btuh
Optional Electric Heat - 15 to 90 kW

MODEL NUMBER IDENTIFICATION

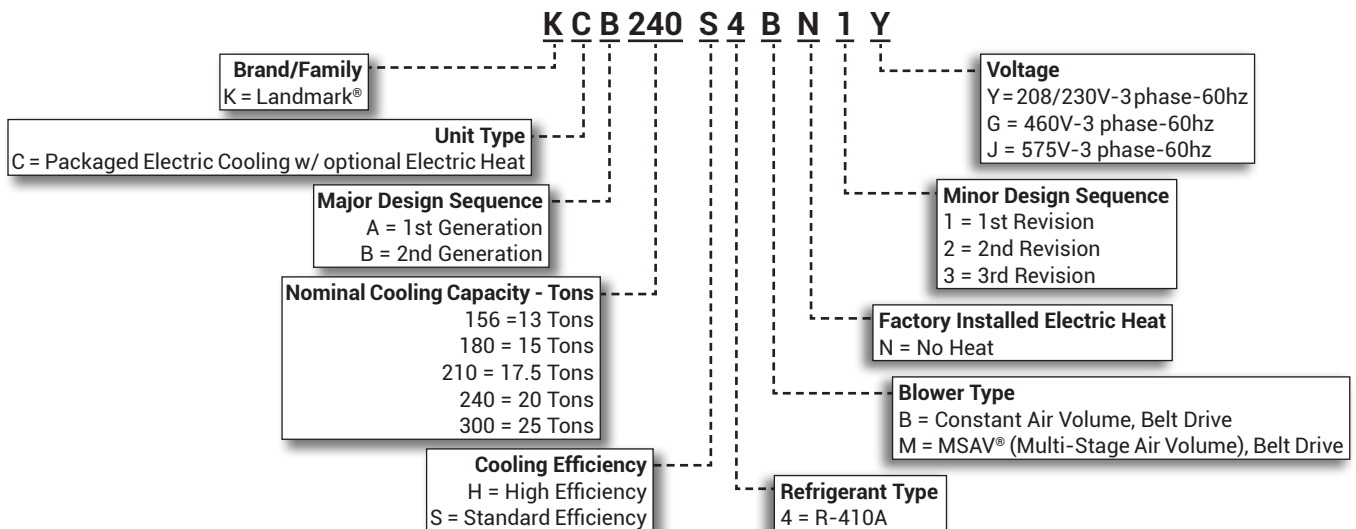

FEATURE HIGHLIGHTS

Landmark® rooftop units from Lennox® are the new standard for reliable, efficient rooftop units built for long-lasting performance that can significantly improve indoor and outdoor environments.

1. Scroll Compressors
2. Thermal Expansion Valves
3. Filter/Driers
4. Lennox' Environ™ Coil System
5. Outdoor Coil Fan Motors
6. Cabinet Construction
7. Constant or Multi-Stage Air Volume (MSAV®) Blower
8. Unit Control
9. Disconnect Switch (option)
10. Electric Heat (option)
11. Air Filters
12. Economizer (option)
13. Downflow Barometric Relief Dampers (option)
14. Power Exhaust Fans (option)

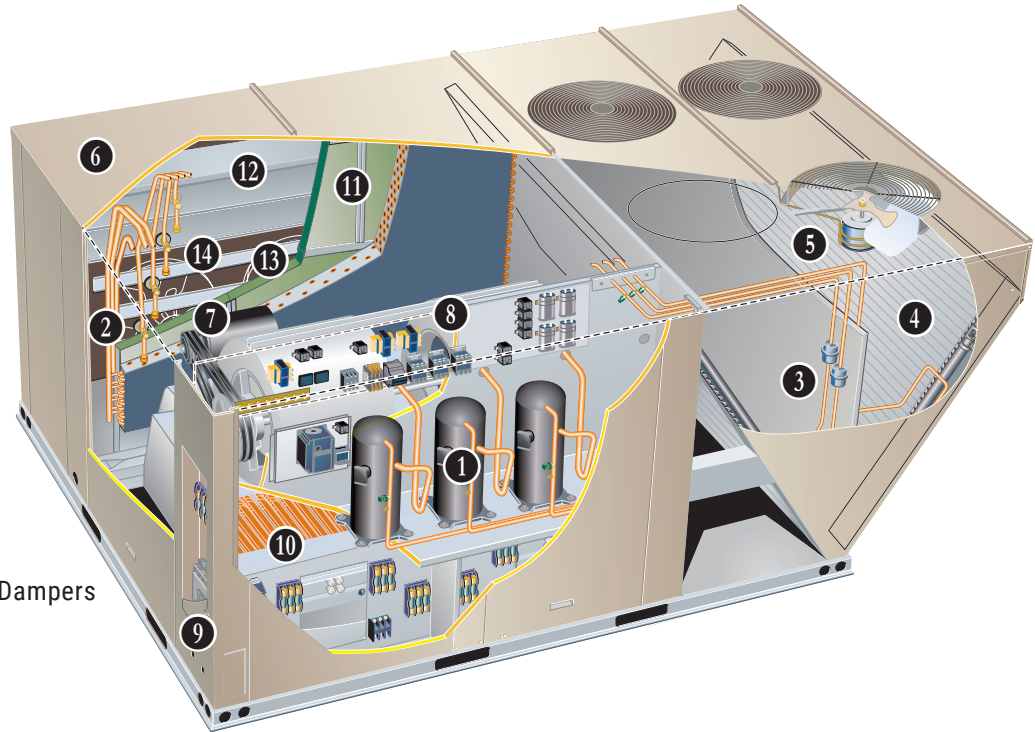

CONTENTS

Approvals and Warranty	3
Blower Data	32
Dimensions - Accessories	48
Dimensions - Unit.	45
Electrical/Electric Heat Data	35
Electric Heat Capacities	43
Features And Benefits	3
Humiditrol® Dehumidification System Option	11
Humiditrol® Dehumidification System Ratings.	30
Model Number Identification.	1
Options / Accessories	13
Outdoor Sound Data	43
Ratings.	22
Specifications	18
Unit Clearances	43
Weight Data	44

APPROVALS AND WARRANTY

APPROVALS

- AHRI Standard 340/360 certified
- ETL and CSA listed
- CSA certified energy ratings
- Unit and components ETL, NEC and CEC bonded for grounding to meet safety standards for servicing
- All models are ASHRAE 90.1-2010 energy efficiency compliant and meet or exceed requirements of Section 6.8
- All models meet DOE 2018 energy efficiency standards
- MSAV models meet California Code of Regulations, Title 24 and ASHRAE 90.1-2010 Section 6.4.3.10 requirements for staged airflow
- ISO 9001 Registered Manufacturing Quality System

WARRANTY

- Compressors - Limited five years
- Lennox' Environ™ Coil System - Limited three years
- Optional High Performance Economizers - Limited five years
- All other covered components - Limited one year

FEATURES AND BENEFITS

COOLING SYSTEM

- Designed to maximize sensible and latent cooling performance at design conditions
- System can operate from 30°F to 125°F without any additional controls

R-410A Refrigerant

- Non-chlorine based
- Ozone-friendly

1 Scroll Compressors

- Scroll compressors on all models for high performance, reliability and quiet operation
- Resiliently mounted on rubber grommets for quiet operation

Compressor Crankcase Heaters

- Protect against refrigerant migration that can occur during low ambient operation

2 Thermal Expansion Valves (All High Efficiency Models, 300S Model and all Standard Efficiency Models with Humiditrol)

- Assures optimal performance throughout the application range
- Removable element head

Refrigerant Metering Orifice (All Standard Efficiency Models except 300S Model)

- Accurately meters refrigerant in system
- Refrigerant control is accomplished by exact sizing of refrigerant metering orifice

3 Filter/Driers

- High capacity filter/drier protects the system from dirt and moisture

High Pressure Switches

- Protects the system from high pressure conditions

Freezestats

- Protects the evaporator coil from damaging ice build-up due to conditions such as low/no airflow, or low refrigerant charge

4 Condenser Coil - Lennox' Environ™ Coil System

Lightweight, all aluminum brazed fin construction

- Constructed of three components
 - A flat extrusion tube
 - Fins in-between the flat extrusion tube
 - Two refrigerant manifolds

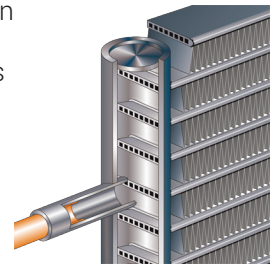

Environ™ Coil System Features:

- Improved heat transfer performance due to high primary surface area (flat tubes) versus secondary surface (fins)
- Smaller internal volume (reduced refrigerant charge)
- High durability
- All aluminum construction
- Fewer brazed joints
- Compact design
- Reduced unit weight
- Easy maintenance/cleaning
- Face split design
- Mounting brackets with rubber inserts
- Angled cabinet design protects coil from damage

FEATURES AND BENEFITS

COOLING SYSTEM (continued)

Evaporator Coil

- Copper tube construction
- Enhanced rippled-edge aluminum fins
- Flared shoulder tubing connections
- Silver soldered construction
- Factory leak tested
- Cross row circuiting with rifled tubing

Condensate Drain Pan

- Plastic pan, sloped to meet drainage requirements of ASHRAE 62.1
- Side or bottom drain connections

5 Outdoor Coil Fan Motors

- Thermal overload protected
- Totally enclosed
- Permanently lubricated ball bearings
- Shaft up
- Wire basket mount

Outdoor Coil Fans

- PVC coated fan guard furnished

Required Selections

Cooling Capacity

- Specify nominal cooling capacity

Options/Accessories

Factory Installed

Conventional Fin/Tube Condenser Coil (replaces Environ™ Coil System, Standard Efficiency Models only)

- Copper tube construction
- Enhanced rippled-edge aluminum fins
- Flared shoulder tubing connections
- Silver soldered construction

NOTE - Required if Humiditrol® Dehumidification System is ordered.

Field Installed

Condensate Drain Trap

- Available in copper or PVC

Drain Pan Overflow Switch

- Monitors condensate level in drain pan, shuts down unit if drain becomes clogged

Low Ambient Controls

- Units operate satisfactorily down to 45°F outdoor air temperature without any additional controls
- Two low ambient control options are available for field installation
 1. **Low Ambient Control Kit (30°F)** - Allows unit operation down to 30°F.
 2. **Low Ambient Control Kit (0°F)** - Allows unit operation down to 0°F without evaporator coil icing
 - Head pressure speed control reduces outdoor fan operation during low ambient conditions until head pressure rises to the setpoint
 - Pressure transducers are mounted on the liquid lines
 - High pressure switches are furnished to replace existing
 - Wiring harnesses are furnished for simple plug-in wiring to fans and controller

CABINET

6 Construction

- Heavy-gauge steel panels
- Full perimeter heavy-gauge galvanized steel base rail
- Base rails have rigging holes
- Three sides of the base rail have forklift slots
- Raised edges around duct and power entry openings in the bottom of the unit for water protection

Airflow Choice

- Units are shipped in downflow (vertical) return air flow configuration

NOTE - Units can be field converted to horizontal air flow with optional Horizontal Return Air Panel Kit and Horizontal Roof Curb.

Power Entry

- Electrical lines can be brought through the unit base or through horizontal access knock-outs

Exterior Panels

- Constructed of heavy-gauge, galvanized steel
- Two-layer enamel paint finish

Insulation

- Fully insulated with non-hygroscopic fiberglass insulation (conditioned areas)
- Unit base is fully insulated
- Base insulation serves as an air seal to the roof curb, eliminating the need to add a seal during installation

Access Panels

- Economizer/Filter section
- Heating/Blower section
- Compressor/Controls section

FEATURES AND BENEFITS

CABINET (continued)

Options/Accessories

Factory Installed

Corrosion Protection

- Completely flexible immersed coating
- Electrodeposited dry film process
- AST ElectroFin E-Coat
- Meets Mil Spec MIL-P-53084, ASTM B117 Standard Method Salt Spray Testing
- Indoor Corrosion Protection:
 - Coated coil
 - Coated reheat coil (Humiditrol®)
 - Painted blower housing
 - Painted base
- Outdoor Corrosion Protection:
 - Coated coil
 - Painted outdoor base

Hinged Access Panels

- Filter section
- Heating/Blower section
- Compressor/Controls section
- Panel seals and quarter-turn latching handles provide a tight air and water seal

Field Installed

Combination Coil/Hail Guards

- Heavy gauge steel frame
- Painted to match cabinet
- Expanded metal mesh protects outdoor coil

Horizontal Return Air Panel Kit

- Required for horizontal applications with Horizontal Roof Curb
- Contains panel with return air opening for field replacement of existing unit panel and panel to cover bottom return air opening in unit
- See dimension drawings

BLOWER

- A wide selection of supply air blower options are available to meet a variety of airflow requirements

Motor

- Overload protected, equipped with ball bearings
- Belt drive motors are offered on all models and are available in several different sizes to maximize air performance

Supply Air Blower

- Forward curved blades
- Double inlet
- Blower wheel statically and dynamically balanced
- Ball bearings
- Adjustable pulley (allows speed change)
- Blower assembly slides out of unit for servicing

Required Selections

7 Select Constant Air Volume (CAV) or MSAV® (Multi-Stage Air Volume)

- Constant Air Volume (CAV) models supply a constant volume of air
- MSAV® (Multi-Stage Air Volume) models utilize a Variable Frequency Drive (VFD) to stage the supply air blower airflow
 - The VFD alters the frequency and voltage of the power supply to the blower to control blower speed
 - The supply air blower has two speeds:
 1. Low speed for part-load cooling operation

NOTE - Low speed is 66% of high speed

2. High speed for full load cooling and all heat modes

- Full speed blower operation is set by adjusting the motor pulley to deliver the desired air volume
- The ventilation speed is selectable between high and low speed

NOTE - Part load airflow in cooling mode on MSAV® models should not be set below 220 cfm/nominal full load ton to reduce the risk of evaporator coil freeze-up.

- The VFD has an operational range of -40 to 125° F outdoor air ambient temperature
- Lower operating costs are obtained when the blower is operated on lower speeds

MSAV® Sequence of Operation

- Ventilation speed is determined by the VENT SPEED switch setting on VFD control board (LO or HI)
- Blower operates in low speed for mechanical cooling (Y1)
- Blower operates in high speed for any other mode (free cooling, mechanical cooling Y1+Y2, and heating)
- Economizer damper minimum position is fully closed in unoccupied mode
- In occupied mode, the economizer damper minimum position is determined by the setting of the two potentiometers on VFD control board:
 - **LO SPD MIN POS** potentiometer sets the minimum position when blower is operating at low speed
 - **HI SPD MIN POS** potentiometer sets the minimum position when blower is operating at high speed

Ordering Information

- Specify standard or high efficiency blower motor, motor horsepower and drive kit number when base unit is ordered

Options/Accessories

Field Installed

VFD Manual Bypass Kit

- VFD Manual Bypass Control is available as a kit for MSAV® equipped models
- The VFD Manual Bypass Control is a manual bypass and is enabled by re-configuring the wiring on the unit

FEATURES AND BENEFITS

CONTROLS

8 Unit Control

- All control voltage is provided via a 24V (secondary) transformer with built-in circuit breaker protection
- Up to 2 heat / 2 cool staging with a third party DDC control system or thermostat
- Low voltage terminal block provides screw terminal connections for thermostat or controller wiring
- Night Setback Mode saves energy by closing outdoor air dampers and operating supply fan on thermostat demand only

Options/Accessories

Field Installed

Smoke Detector

- Photoelectric type
- Installed in supply air section, return air section or both sections
- Available with power board and single sensor (supply or return) or power board and two sensors (supply and return)
- Power board located in unit control compartment

Commercial Control Systems

L Connection® Network

- Complete building automation control system for single or multi-zone applications
- Options include local interface, software for local or remote communication, and hardware for networking other control functions
- See L Connection Network Product Specifications Bulletin for details

NOTE - Not available for Humiditrol® equipped units.

Thermostats

- Control system and thermostat options see page 10

ELECTRICAL

- All units include terminal block and fuse block in power entry junction box for single power entry application

Marked & Color-Coded Wiring

- All electrical wiring is color-coded and marked to identify which components it is connecting

Electrical Plugs

- Positive connection electrical plugs are used to connect common accessories or maintenance parts for easy removal or installation

Required Selections

Voltage Choice

- Specify when ordering base unit

Options/Accessories

Factory or Field Installed

9 Disconnect Switch

- Accessible from outside of unit
- Spring loaded weatherproof cover furnished

GFI Service Outlets (2)

- 115V ground fault circuit interrupter (GFCI) type
- Non-powered
- Field-wired

Field Installed

10 Electric Heat

- Helix wound nichrome elements
- Individual element limit controls
- Wiring harness
- Unit fuse block
- See Options / Accessories tables for ordering information

GFI Weatherproof Cover

- Single-gang cover
- Heavy-duty UV-resistant polycarbonate case construction
- Hinged base cover with gasket

Phase Monitor

- Phase monitor detects the phasing of incoming power
- If the incoming power is out of phase or if any of the three phases are lost red LED on the phase monitor will light and the unit will not start
- Green LED indicates normal operation with correct incoming power phasing

NOTE - Phase Monitor is factory Installed in the control compartment on all units equipped with the MSAV® Supply Air Blower option.

FEATURES AND BENEFITS

INDOOR AIR QUALITY

- 11** Air Filters
- Disposable 2 inch filters furnished as standard

Options/Accessories

Field Installed

Healthy Climate® High Efficiency Air Filters

- Disposable MERV 8 or MERV 13 (Minimum Efficiency Reporting Value based on ASHRAE 52.2) efficiency
- 2 inch pleated filters

Healthy Climate® UVC Germicidal Lamps

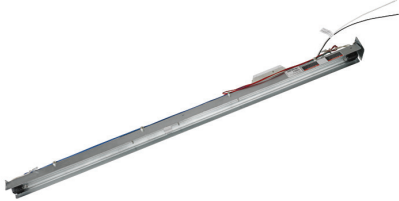

- Germicidal lamps emit ultra-violet (UV-C) energy, which has been proven to be effective in reducing microbes such as viruses, bacteria, yeasts, and molds
- This process either destroys the organism or controls its ability to reproduce
- UV-C energy greatly reduces the growth and proliferation of mold and other bioaerosols (bacteria and viruses) on illuminated surfaces (particularly coil and drain pan)
- Field installed in the blower/evaporator coil section
- All necessary hardware for installation is included
- Lamps operate on 208/230V power supply

NOTE - Step-down transformer must be field supplied when used with 460V and 575V rooftop units

- Magnetic safety interlock terminates power when access panels are removed
- Approved by ETL

Indoor Air Quality (CO2) Sensors

- Monitors CO2 levels
- Reports to the Unit Controller which adjusts economizer dampers as needed

OPTIONS/ACCESSORIES

ECONOMIZER

Factory or Field Installed

- 12** Economizer (Standard and High Performance Common Features)
- Outdoor Air Hood with mist elimination filter furnished
 - Mixed Air Sensor furnished for field installation in the rooftop unit

NOTE - Sensor is factory installed when Economizer is factory installed.

Standard Economizer Features (Not for Title 24)

- Gear-driven action
- 24-volt, fully-modulating spring return motor
- Return air and outdoor air dampers
- Plug-in connections to unit
- Nylon bearings
- Neoprene seals

Standard Economizer Control Module (Not for Title 24)

- Standard Economizer Control Module operation is based on outdoor air temperatures

Economizer Controls:

- **Damper Minimum Position** - Can be set lower than traditional minimum air requirements resulting in cost savings
- **IAQ Sensor** - Signals dampers to modulate and maintain 55°F when CO2 is higher than the CO2 setpoint
- **Demand Control Ventilation (DCV) LED** - A steady green Demand Control Ventilation LED indicates the IAQ reading is higher than setpoint and requires more fresh air
- **Free Cool LED** - A steady green LED indicates outdoor air is suitable for free cooling
 - Free Cooling runs when outdoor air temperature is lower than the set temperature on the economizer control.



NOTE: The Free Cooling default setting for outdoor air temperature sensor is 55°F.

OPTIONS/ACCESSORIES

ECONOMIZER (continued)

High Performance Economizer Features

- Approved for California Title 24 building standards
- Low leakage dampers are Air Movement and Control Association International (AMCA) Class 1A Certified - Maximum 3 CFM per sq. ft. leakage at 1 in. w.g.
- ASHRAE 90.1-2010 compliant
- Gear-driven action
- High torque 24-volt fully-modulating spring return damper motor
- Return air and outdoor air dampers
- Plug-in connections to unit
- Stainless steel bearings
- Enhanced neoprene blade edge seals
- Flexible stainless steel jamb seals

NOTE - High Performance Economizers are not approved for use with enthalpy controls in Title 24 applications.

High Performance Economizer Control Module

- Provides inputs and outputs to control economizer based on parameter settings
- Automatically detects sensors by polling to determine which sensors are installed in system
- Displays any alarm messages (fault detection and diagnostics) as an aid in troubleshooting
- Non-volatile memory retains parameter settings in case of power failure
- Keypad with four navigation buttons and LCD screen is furnished for setting economizer parameters
 - Menu Up/Exit (↑) button returns to the main menu
 - Arrow Up (▲) button moves to the previous or next parameter within the selected menu
 - Arrow Down (▼) button moves to the next parameter within the selected menu
 - Select (enter) (↵) button confirms parameter selection
- Main Menu Structure
 - **Status** (economizer and system operation status)
 - **Setpoints** (settings for various setpoint parameters)
 - **System Setup** (settings/information about the system)
 - **Advanced Setup** (freeze protection, CO2 settings, stage 3 delay and additional calibration settings)
 - **Checkout** (damper positions)
 - **Alarms** (output signal that can be configured for remote alarm monitoring)



NOTE - The Free Cooling setpoint for Title 24 applications must be set based on the Climate Zone where the system is installed. See Section 140.4 "Prescriptive Requirements for Space Conditioning Systems" of the California Energy Commission's 2013 Building Energy Efficiency Standards.

NOTE - Refer to Installation Instructions for complete setup information and menu parameters available

Factory or Field Installed

Single Enthalpy Temperature Control (Not for Title 24)

- Outdoor air enthalpy sensor enables Economizer if the outdoor enthalpy is less than the setpoint of the control

Field Installed

Differential Enthalpy Control (Not for Title 24)

- Order two Single Enthalpy Controls
- One is field installed in the return air section, the other in the outdoor air section
- Allows the economizer control board to select between outdoor air or return air, whichever has lower enthalpy

EXHAUST

Factory or Field Installed

13 Downflow Barometric Relief Dampers With Exhaust Hood

- Allow relief of excess air
- Aluminum blade dampers prevent blow back and outdoor air infiltration during off cycle
- Exhaust hood with bird screen is furnished

Field Installed

Horizontal Barometric Relief Dampers With Exhaust Hood

- For use when unit is configured for horizontal applications requiring an economizer
- Allows relief of excess air
- Aluminum blade dampers prevent blow back and outdoor air infiltration during off cycle
- Field installed in return air duct
- Exhaust hood with bird screen is furnished

14 Power Exhaust Fans

- Installs internal to unit for downflow applications only with economizer option
- Provides exhaust air pressure relief
- Interlocked to run when supply air blower is operating, fans run when outdoor air dampers are 50% open (adjustable)
- Motor is overload protected
- Dual fans
- 20 in. diameter
- 5 blades
- Two 1/3 hp motors

NOTE - Requires Economizer with Outdoor Air Hood and Downflow Barometric Relief Dampers

OPTIONS/ACCESSORIES

OUTDOOR AIR

Factory or Field Installed

Outdoor Air Damper - Downflow or Horizontal With Air Hood

- Linked mechanical dampers
- 0 to 25% (fixed) outdoor air adjustable
- Installs in unit
- Includes outdoor air hood
- Automatic model features fully modulating spring return damper motor with plug-in connection
- Manual model features parallel blade, gear-driven dampers with adjustable fixed position

NOTE - Outdoor Air Hood is included when damper is factory installed and is furnished with damper when ordered for field installation.

ROOF CURBS

- Nailer strip furnished (downflow only)
- Mates to unit
- US National Roofing Contractors Approved
- Shipped knocked down

Downflow

Hybrid Roof Curbs

- Interlocking tabs fasten corners together
- No tools required
- Can also be fastened together with furnished hardware
- Available in 8, 14, 18, and 24 inch heights

Adjustable Pitch Curb

- Fully adjustable pitch curbs (3/4 in. per foot in any direction) provide a level platform for rooftop units allowing flexible installations on roofs with uneven or sloped angles
- Uses interlocking tabs to fasten corners together. No tools required
- Hardware is furnished to connect upper curb with lower curb
- Available in 14 inch height

Horizontal

- Meet National Roofing Code requirements
- Converts unit from downflow to horizontal (side) air flow
- Return air is on unit, supply air is on curb
- See dimension drawings
- Available in 26, 30, 37 and 41 inch heights

NOTE - Requires Horizontal Return Air Panel Kit.

NOTE - Optional Insulation Kit is available to help prevent sweating.

Adaptor Curbs (not shown)

- Curbs are regionally sourced
- Dimensions vary based upon the source

NOTE - Contact your local sales representative for a detailed cut sheet with applicable dimensions.

CEILING DIFFUSERS

Field Installed

Ceiling Diffusers (Flush or Step-Down)

- White powder coat finish on diffuser face and grilles
- Insulated UL listed duct liner
- Diffuser box has collars for duct connection
- Step-down diffusers have double deflection blades
- Flush diffusers have fixed blades
- Provisions for suspending
- Internally sealed to prevent recirculation
- Removable return air grille
- Adapts to T-bar ceiling grids or plaster ceilings

Transitions (Supply and Return)

- Used with diffusers
- Installs in roof curb
- Galvanized steel construction
- Flanges furnished for duct connection to diffusers
- Fully insulated

OPTIONAL CONVENTIONAL TEMPERATURE CONTROL SYSTEMS

Comfortsense® 7500 Commercial 7-Day Programmable Thermostat



- Four-Stage Heating / Two-Stage Cooling
- Universal Multi-Stage
- Intuitive Touchscreen Interface
- Automatic Changeover between Heating and Cooling
- Full Seven-Day Programming
- Four Time Periods Per Day
- Temperature and Humidity Control
- One-Touch Away Mode
- Holiday Scheduling
- Smooth Setback Recovery (SSR)
- Performance Reports
- Notifications/Reminders
- Dehumidification/Humiditrol® Control for Split Systems and Rooftop Units
- Economizer Relay Control
- Backlit Display
- Wallplate Furnished
- FDD, ASHRAE and IECC Compliant

Comfortsense® 3000 Commercial 5-2 Day Programmable Thermostat



- Two-Stage Heating / Two-Stage Cooling
- Conventional Systems
- Intuitive Interface
- 5-2 Day Programming
- Program Hold
- Remote Indoor Temperature Sensing
- Smooth Setback Recovery (SSR)
- Economizer Relay Control
- Maintenance/Filter/Service Reminders
- Backlit Display
- Wallplate Furnished
- Simple Up and Down Temperature Control

Bacnet Compatible Thermostat With Reheat Function



- 7-Day Programmable
- For units with or without Humiditrol®
- BTL listed MS/TP ensures compatibility with any BACnet system
- Built-in control programs for conventional and heat pump applications
- Conventional systems up to 3-stage heat and 3-stage cool
- Heat pumps with 1 or 2 compressors and up to 2-stage auxiliary heat
- On-board temperature and humidity sensor
- Multiple configurable inputs and outputs enable advanced control strategies
- Set-up Wizard enables rapid system configuration
- No special tools required for installation or commissioning
- Seven-day (2, 4 or 6 event) occupancy scheduling per day
- Backlit 5-inch LCD touchscreen

Description	Model No.	Catalog No.
Comfortsense® 7500 7-Day Programmable	C0STAT06FF2L	17G74
Universal thermostat locking guard (clear)	C0MISC15AE1-	39P21
Temperature Sensors ¹ Remote non-adjustable wall-mount 20k	C0SNZN01AE2-	47W36
¹ Remote non-adjustable wall-mount 10k	C0SNZN73AE1-	47W37
Remote non-adjustable discharge air (duct mount)	C0SNDC00AE1-	19L22
Outdoor temperature sensor	C0SNSR03AE1-	X2658
Comfortsense® 3000 5-2 Day Programmable	C0STAT05FF1L	11Y05
Thermostat wall mounting plate	C0MISC17AE1-	X2659
Temperature Sensor Remote non-adjustable wall mount 10k averaging	C0SNZN73AE1-	47W37
¹ 7-Day Programmable - Bacnet Compatible	- - -	Y8241

¹ Remote wall-mount sensors can be applied in any of the following combinations:

- One Sensor - (1) 47W36
- Two Sensors - (2) 47W37
- Three Sensors - (2) 47W36 and (1) 47W37
- Four Sensors - (4) 47W36
- Five Sensors - (3) 47W36 and (2) 47W37

¹ BACnet Thermostat (Y8241) will control units with and without the Humiditrol® option. If there is a mix of units equipped with and without Humiditrol on the same site, this thermostat can be used for all units if desired.

HUMIDITROL® DEHUMIDIFICATION SYSTEM OPTION

OVERVIEW

NOTE - Not available with Environ™ Coil System.
Conventional Fin/Tube condenser coil must be ordered as a factory option.

- Factory installed option designed to control humidity
- Provides dehumidification on demand using ASHRAE 90.1 recommended method for comfort conditioning humidity control
- Unit comes equipped with one row reheat coil, solenoid valve and humidity controller
- A thermostat with a dehumidification output, a dehumidistat, or a DDC controller with an isolated output is required to control humidity and must be located in the occupied space

BENEFITS

- Improves indoor air quality
- Helps prevent damage due to high humidity levels
- Improves comfort levels by reducing space humidity levels

OPERATION

No Dehumidification Demand

- The unit will operate conventionally whenever there is a demand for cooling or heating and no dehumidification demand
- Free cooling is only permitted when there is no demand for dehumidification

Dehumidification Demand Only

- Dehumidification is initiated by an output from a dehumidistat (furnished), an optional thermostat with a dehumidification output or an optional DDC controller with an isolated output to control humidity
- Reheat operation will initiate on a dehumidification demand and does not require a cooling demand
- The unit will operate in the dehumidification mode until the relative humidity of the conditioned space is below the setpoint
- This reduces sensible cooling capacity and extends compressor run time to control humidity when the cooling load is low
- A solenoid valve diverts hot gas from the compressor to the reheat coil
- The cooled and dehumidified air from the evaporator is reheated as it passes through the reheat coil
- The de-superheated and partially condensed refrigerant continues to the outdoor condenser coil where condensing is completed
- The unit will continue to operate in this mode until the dehumidification demand is satisfied

Dehumidistat Furnished

- Furnished for field installation
- Remote mounted dehumidistat for factory installed Humiditrol® option
- Adjustable 20-80%

NOTE - A thermostat with a dehumidification output or a DDC controller with an isolated output can be used instead.

NOTE - See Conventional Thermostat Control Systems on page 10 for additional Humiditrol® control options.

HUMIDITROL® DEHUMIDIFICATION SYSTEM OPTION

REFRIGERANT SCHEMATIC (180S and 210S MODELS ONLY)

NOTE: Refrigerant circuits one and two operates when there is a first-stage thermostat demand.

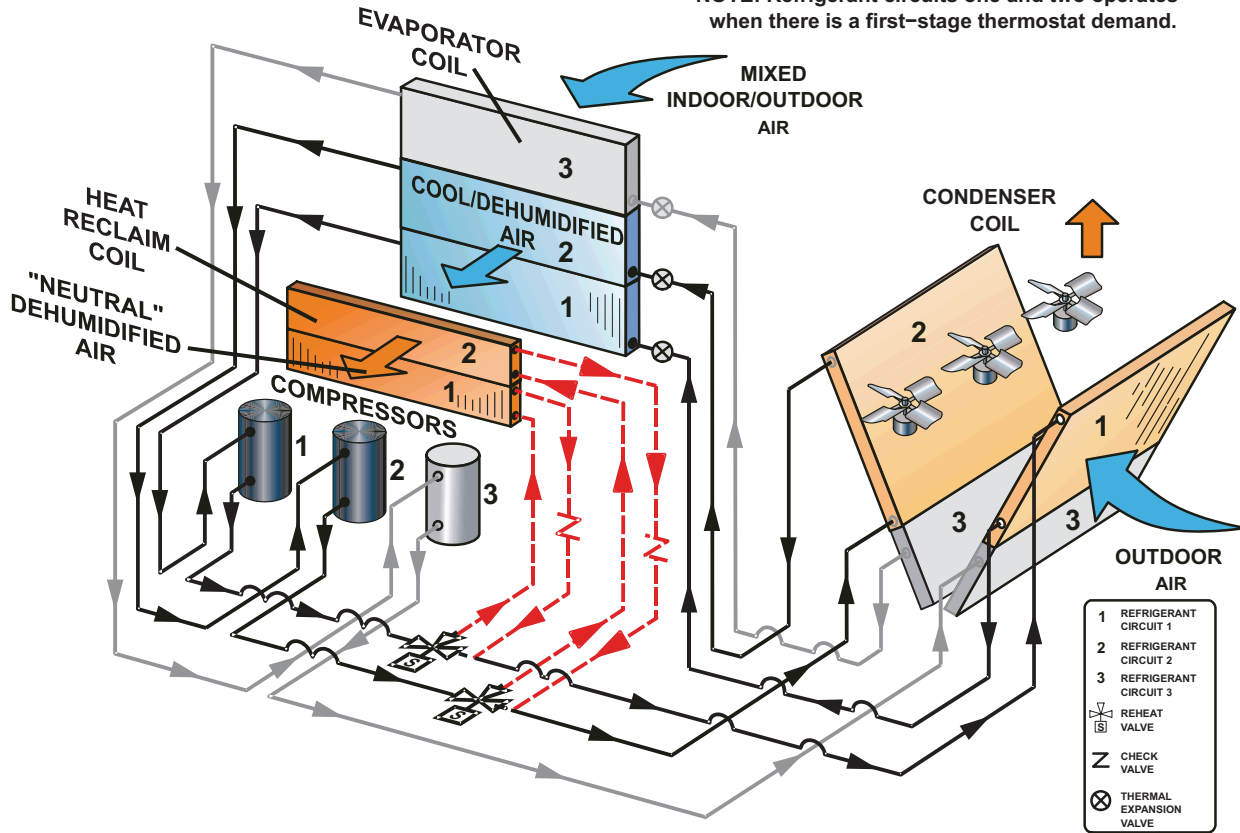

REFRIGERANT SCHEMATIC (240S and 300S MODELS ONLY)

NOTE: Refrigerant circuits one and two operates when there is a first-stage thermostat demand.

NOTE: 300S model has six fans.

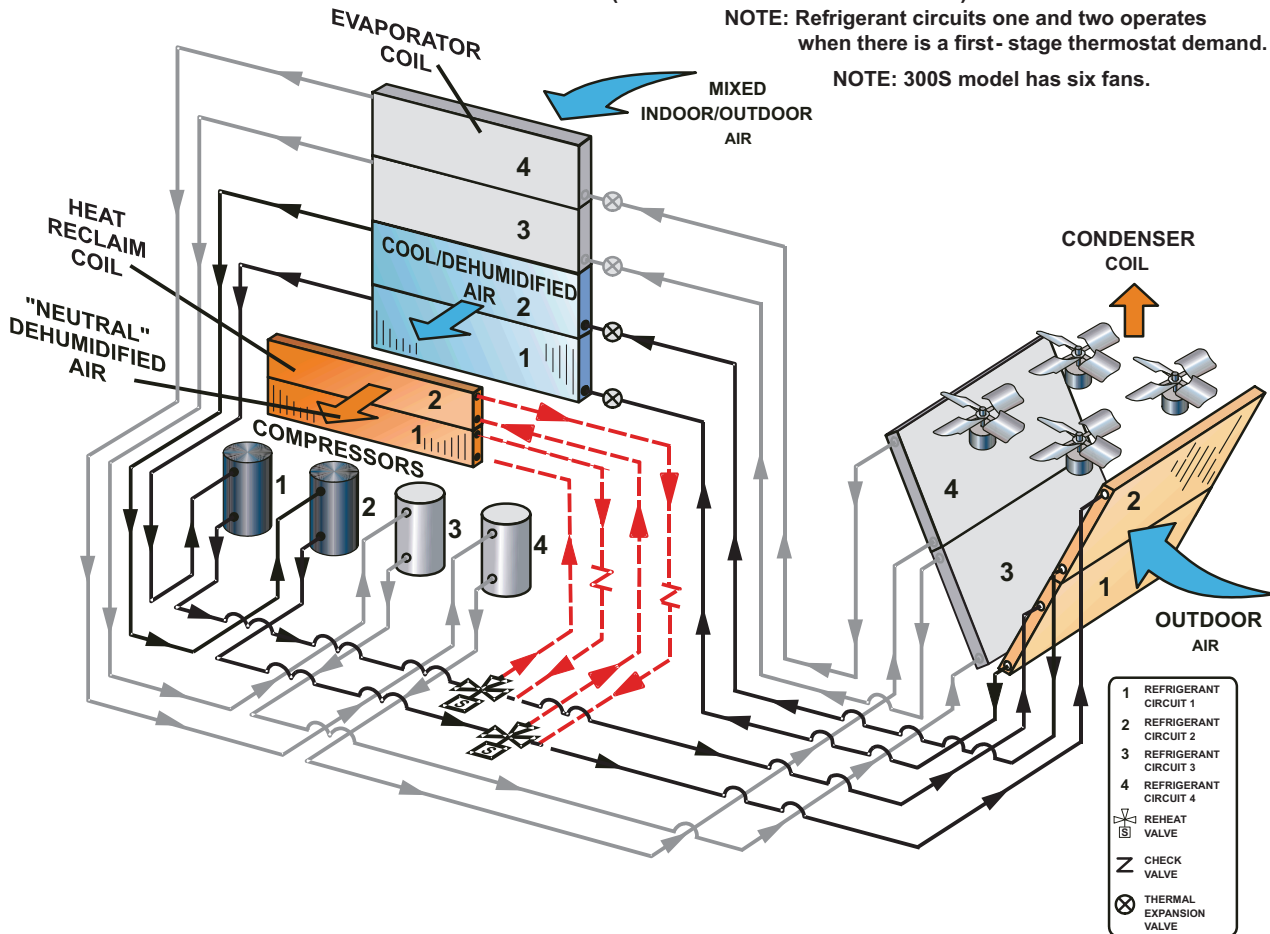

OPTIONS / ACCESSORIES

STANDARD AND HIGH EFFICIENCY MODELS

Item Description	Model Number	Catalog Number	Unit Model No.					
			KCA 156	KCA KCB 180	KCA KCB 210	KCA KCB 240	KCB 300	
COOLING SYSTEM								
Condensate Drain Trap	PVC - C1TRAP20AD2	76W26	X	X	X	X	X	
	Copper - C1TRAP10AD2	76W27	X	X	X	X	X	
Corrosion Protection		Factory	O	O	O	O	O	
Drain Pan Overflow Switch	C1SNSR71FF1-	10C24	X	X	X	X	X	
Efficiency	Standard or High	Factory	O	O	O	O	O	
Refrigerant Type		R-410A	O	O	O	O	O	
BLOWER - SUPPLY AIR								
Blower Option	CAV (Constant Air Volume)	Factory	O	O	O	O	O	
	MSAV® (Multi-Stage Air Volume)	Factory	O	O	O	O	O	
Motors - Constant Air Volume (CAV)	Belt Drive (standard efficiency) - 2 hp	Factory	O					
	Belt Drive (standard efficiency) - 3 hp	Factory	O	O	O			
	Belt Drive (standard efficiency) - 5 hp	Factory	O	O	O	O	O	
	Belt Drive (standard efficiency) - 7.5 hp	Factory		O	O	O	O	
	Belt Drive (standard efficiency) - 10 hp	Factory				O	O	
Motors - MSAV® (Multi-Stage Air Volume)	Belt Drive (standard efficiency) - 2 hp	Factory	O					
	Belt Drive (standard efficiency) - 3 hp	Factory	O	O	O			
	Belt Drive (standard efficiency) - 5 hp	Factory	O	O	O	O	O	
	Belt Drive (standard efficiency) - 7.5 hp	Factory		O	O	O	O	
	Belt Drive (standard efficiency) - 10 hp	Factory				O	O	
VFD Manual Bypass Kit (for MSAV® equipped units)	2, 3, 5 hp (208/230V)	KVFDB11C-1	90W52	X	X	X	X	X
	2, 3, 5, 7.5, 10 hp (460V and 575V)							
Drive Kits See Blower Data Tables for usage and selection	7.5, 10 hp (208/230V)	KVFDB10C-1	90W51		X	X	X	X
	Kit #1 535-725 rpm	Factory		O	O	O		
	Kit #2 710-965 rpm	Factory		O	O	O		
	Kit #3 685-856 rpm	Factory		O	O	O	O	O
	Kit #4 850-1045 rpm	Factory		O	O	O	O	O
	Kit #5 945-1185 rpm	Factory		O	O	O	O	O
	Kit #6 850-1045 rpm	Factory			O	O	O	O
	Kit #7 945-1185 rpm	Factory			O	O	O	O
	Kit #8 1045-1285 rpm	Factory			O	O	O	O
	Kit #10 1045-1285 rpm	Factory					O	O
	Kit #11 1135-1365 rpm	Factory					O	O
CABINET								
Hinged Access Panels		Factory	O	O	O	O	O	
CONTROLS								
NOTE - Also see Conventional Thermostat Control Systems on page 10 for additional control options.								
Smoke Detector - Supply or Return (Power board and one sensor)	C1SNSR44C-1	83W40	X	X	X	X	X	
Smoke Detector - Supply and Return (Power board and two sensors)	C1SNSR43C-1	83W41	X	X	X	X	X	
L Connection® Building Automation System		- - -	X	X	X	X	X	

NOTE - Catalog and model numbers shown are for ordering field installed accessories.

OX - Configure To Order (Factory Installed) or Field Installed

O = Configure To Order (Factory Installed)

X = Field Installed

OPTIONS / ACCESSORIES

STANDARD AND HIGH EFFICIENCY MODELS

Item Description	Model Number	Catalog Number	Unit Model No.				
			KCA 156	KCA KCB 180	KCA KCB 210	KCA KCB 240	KCB 300
ELECTRICAL							
Voltage 60 hz	208/230V - 3 phase	Factory	O	O	O	O	O
	460V - 3 phase	Factory	O	O	O	O	O
	575V - 3 phase	Factory	O	O	O	O	O
Disconnect Switch (see Electric Heat Tables for usage)	80 amp - C1DISC080C-1	54W85	OX	OX	OX	OX	OX
	150 amp - C1DISC150C-1	54W86	OX	OX	OX	OX	OX
	250 amp - C1DISC250C-1	54W87	OX	OX	OX	OX	OX
GFI Service Outlets	15 amp non-powered, field-wired (208/230V, 460V only) LTAGFIK10/15	74M70	X	OX	OX	OX	OX
	20 amp non-powered, field-wired (575V only) C1GFCI20FF1	67E01	X	X	X	X	X
Weatherproof Cover for GFI	C1GFCI99FF1	10C89	X	X	X	X	X
¹ Phase Monitor	C1PHZM01FF1-	10C25	X	X	X	X	X
² ELECTRIC HEAT							
15 kW	208/230V-3ph - C1EH0150C-1Y	53W84	OX	OX	OX	OX	OX
	460V-3ph - C1EH0150C-1G	53W86	OX	OX	OX	OX	OX
	575V-3ph - C1EH0150C-1J	53W87	OX	OX	OX	OX	OX
30 kW	208/230V-3ph - C1EH0300C11Y	53W88	OX				
	460V-3ph - C1EH0300C11G	53W90	OX				
	575V-3ph - C1EH0300C11J	53W91	OX				
	208/230V-3ph - C1EH0300C21Y	53W92		OX	OX	OX	OX
	460V-3ph - C1EH0300C21G	53W94		OX	OX	OX	OX
	575V-3ph - C1EH0300C21J	53W95		OX	OX	OX	OX
45 kW	208/230V-3ph - C1EH0450C11Y	53W96	OX				
	460V-3ph - C1EH0450C11G	53W98	OX				
	575V-3ph - C1EH0450C11J	53W99	OX				
	208/230V-3ph - C1EH0450C21Y	54W00		OX	OX	OX	OX
	460V-3ph - C1EH0450C21G	54W02		OX	OX	OX	OX
	575V-3ph - C1EH0450C21J	54W03		OX	OX	OX	OX
60 kW	208/230V-3ph - C1EH0600C11Y	54W04	OX				
	460V-3ph - C1EH0600C11G	54W06	OX				
	575V-3ph - C1EH0600C11J	54W07	OX				
	208/230V-3ph - C1EH0600C21Y	54W08		OX	OX	OX	OX
	460V-3ph - C1EH0600C21G	54W10		OX	OX	OX	OX
	575V-3ph - C1EH0600C21J	54W11		OX	OX	OX	OX
90 kW	208/230V-3ph - C1EH0900C-1Y	54W12			OX	OX	OX
	460V-3ph - C1EH0900C-1G	54W14			OX	OX	OX
	575V-3ph - C1EH0900C-1J	54W15			OX	OX	OX

¹ Factory installed on all MSAV® equipped units.

² NOTE - Factory installed electric heat is only available with high efficiency models.

NOTE - Catalog and model numbers shown are for ordering field installed accessories.

OX = Configure To Order (Factory Installed) or Field Installed

O = Configure To Order (Factory Installed)

X = Field Installed

OPTIONS / ACCESSORIES

STANDARD AND HIGH EFFICIENCY MODELS

Item Description	Model Number	Catalog Number	Unit Model No.				
			KCA 156	KCA KCB 180	KCA KCB 210	KCA KCB 240	KCB 300
INDOOR AIR QUALITY							
Air Filters							
Healthy Climate® High Efficiency Air Filters 24 x 24 x 2 in. (Order 6 per unit)	MERV 8 - C1FLTR15C-1-	54W67	X	X	X	X	X
	MERV 13 - C1FLTR40C-1-	52W40	X	X	X	X	X
Replacement Media Filter With Metal Mesh Frame (includes non-pleated filter media)	C1FLTR30C-1-	44N61	X	X	X	X	X
Indoor Air Quality (CO2) Sensors							
Sensor - Wall-mount, off-white plastic cover with LCD display	C0SNSR50AE1L	77N39	X	X	X	X	X
Sensor - Wall-mount, off-white plastic cover, no display	C0SNSR52AE1L	87N53	X	X	X	X	X
Sensor - Black plastic case with LCD display, rated for plenum mounting	C0SNSR51AE1L	87N52	X	X	X	X	X
Sensor - Wall-mount, black plastic case, no display, rated for plenum mounting	C0MISC19AE1	87N54	X	X	X	X	X
CO2 Sensor Duct Mounting Kit - for downflow applications	C0MISC19AE1-	85L43	X	X	X	X	X
Aspiration Box - for duct mounting non-plenum rated CO2 sensors (87N53 or 77N39)	C0MISC16AE1-	90N43	X	X	X	X	X
UVC Germicidal Light Kit							
¹ Healthy Climate® UVC Light Kit (110/230V-1ph)	C1UVCL10C-1	54W65	X	X	X	X	X
ECONOMIZER							
Standard Economizer With Outdoor Air Hood (Not for Title 24)							
Standard Economizer Downflow or Horizontal Applications - Includes Outdoor Air Hood, order Downflow or Horizontal Barometric Relief Dampers separately	K1ECON20C-3	13U48	OX	OX	OX	OX	OX
Standard Economizer Controls (Not for Title 24)							
Single Enthalpy Control	C1SNSR64FF1	53W64	OX	OX	OX	OX	OX
Differential Enthalpy Control (order 2)	C1SNSR64FF1	53W64	X	X	X	X	X
High Performance Economizer With Outdoor Air Hood (For Title 24) / AMCA Class 1A Certified							
High Performance Economizer Downflow or Horizontal Applications - Includes Outdoor Air Hood, order Downflow or Horizontal Barometric Relief Dampers separately	K1ECON22C-3	16Y99	OX	OX	OX	OX	OX
High Performance Economizer Controls (Not for Title 24)							
Single Enthalpy Control	C1SNSR60FF1	10Z75	OX	OX	OX	OX	OX
Differential Enthalpy Control (order 2)	C1SNSR60FF1	10Z75	X	X	X	X	X
Barometric Relief Dampers With Exhaust Hood							
Downflow Barometric Relief Dampers	C1DAMP50C	54W78	OX	OX	OX	OX	OX
Horizontal Barometric Relief Dampers	LAGEDH18/24	16K99	X	X	X	X	X
OUTDOOR AIR							
Outdoor Air Dampers With Outdoor Air Hood							
Motorized	C1DAMP20C-1	13U04	OX	OX	OX	OX	OX
Manual	C1DAMP10C-2	13U05	OX	OX	OX	OX	OX
POWER EXHAUST (DOWNFLOW APPLICATIONS ONLY)							
Standard Static	208/230V - C1PWRE11C-1Y	75W90	X	X	X	X	X
	460V - C1PWRE11C-1G	75W91	X	X	X	X	X
	575V - C1PWRE11C-1J	75W92	X	X	X	X	X

¹ Lamps operate on 110-230V single-phase power supply. Step-down transformer must be field supplied for field installation in 460V and 575V rooftop units (transformer is furnished for factory installed light kits). Alternately, a separate 110V power supply may be used to directly power the UVC ballast(s)

NOTE - Catalog and model numbers shown are for ordering field installed accessories.

OX - Configure To Order (Factory Installed) or Field Installed

O = Configure To Order (Factory Installed)

X = Field Installed

OPTIONS / ACCESSORIES

STANDARD AND HIGH EFFICIENCY MODELS

Item Description	Model Number	Catalog Number	Unit Model No.				
			KCA 156	KCA KCB 180	KCA KCB 210	KCA KCB 240	KCB 300
ROOF CURBS							
Hybrid Roof Curbs, Downflow							
8 in. height	C1CURB70C-1	11F58	X	X	X	X	X
14 in. height	C1CURB71C-1	11F59	X	X	X	X	X
18 in. height	C1CURB72C-1	11F60	X	X	X	X	X
24 in. height	C1CURB73C-1	11F61	X	X	X	X	X
Adjustable Pitch Curb							
14 in. height	L1CURB55C	43W26	X	X	X	X	X
Standard Roof Curbs, Horizontal - Requires Horizontal Return Air Panel Kit							
26 in. height - slab applications	C1CURB14C-1	11T89	X	X	X	X	
30 in. height - slab applications	C1CURB15C-1	11T90					X
37 in. height - rooftop applications	C1CURB16C-1	11T96	X	X	X	X	
41 in. height - rooftop applications	C1CURB17C-1	11T97					X
Insulation Kit For Standard Horizontal Curbs							
for C1CURB14C-1	C1INSU11C-1-	73K32	X	X	X	X	
for C1CURB15C-1	C1INSU12C-1-	73K33					X
for C1CURB16C-1	C1INSU13C-1-	73K34	X	X	X	X	
for C1CURB17C-1	C1INSU14C-1-	73K35					X
Horizontal Return Air Panel Kit							
Required for Horizontal Applications with Roof Curb	C1HRAP10C-1-	87M00	X	X	X	X	X
CEILING DIFFUSERS							
Step-Down - Order one	RTD11-185S	13K63	X	X			
	RTD11-275S	13K64			X	X	X
Flush - Order one	FD11-185S	13K58	X	X			
	FD11-275S	13K59			X	X	X
Transitions (Supply and Return) - Order one	C1DIFF33C-1	12X68	X	X			
	C1DIFF34C-1	12X70			X	X	X

NOTE - Catalog and model numbers shown are for ordering field installed accessories.
 OX - Configure To Order (Factory Installed) or Field Installed
 O = Configure To Order (Factory Installed)
 X = Field Installed

OPTIONS / ACCESSORIES

STANDARD EFFICIENCY MODELS ONLY

Item Description	Model Number	Catalog Number	Unit Model No.			
			KCB 180S	KCB 210S	KCB 240S	KCB 300S
COOLING SYSTEM						
Conventional Fin/Tube Condenser Coil (replaces Environ™ Coil System) (Required for Humiditrol® option)		Factory	O	O	O	O
Low Ambient Kits	30°F - K1LOAM53C11	10T63	X	X		
	30°F - K1LOAM53C21	10T64			X	
	30°F - K1LOAM54C21	10T65				X
	0°F - K1LOAM63C11	18B95	X	X		
	0°F - K1LOAM63C21	18B96			X	
	0°F - K1LOAM64C31	18B98				X
CABINET						
Combination Coil/Hail Guards	Environ™ Coil System - C1GARD52C12	15T92	X	X		
	Environ™ Coil System - C1GARD52C22	15T93			X	X
	Conventional Fin/Tube Condenser Coil - C1GARD51C11	13T08	X	X		
	Conventional Fin/Tube Condenser Coil - C1GARD51C21	13T12			X	X
HUMIDITROL® CONDENSER REHEAT OPTION						
Humiditrol® Dehumidification Option		Factory	O	O	O	O
¹ Dehumidistat, Remote Mounted	C0SNSR30FF1L	99N41	X	X	X	X

¹ A thermostat with a dehumidification output or a DDC controller with an isolated output can be used instead.

NOTE - Catalog and model numbers shown are for ordering field installed accessories.

OX - Configure To Order (Factory Installed) or Field Installed

O = Configure To Order (Factory Installed)

X = Field Installed

OPTIONS / ACCESSORIES

HIGH EFFICIENCY MODELS ONLY

Item Description	Model Number	Catalog Number	Unit Model No.			
			KCA 156H	KCA 180H	KCA 210H	KCA 240H
COOLING SYSTEM						
Low Ambient Control	30°F - K1LOAM53C11	10T63	X			
	30°F - K1LOAM53C21	10T64		X	X	
	30°F - K1LOAM54C21	10T65				X
	0°F - K1LOAM63C11	18B95	X			
	0°F - K1LOAM63C21	18B96		X		
	0°F - K1LOAM63C31	18B97			X	
	0°F - K1LOAM64C31	18B98				X
CABINET						
Combination Coil/Hail Gurards	Environ™ Coil System - C1GARD52C12	15T92	X			
	Environ™ Coil System - C1GARD52C22	15T93		X	X	X
	Conventional Fin/Tube Condenser Coil - C1GARD51C11	13T08	X			
	Conventional Fin/Tube Condenser Coil - C1GARD51C21	13T12		X	X	X

NOTE - Catalog and model numbers shown are for ordering field installed accessories.

OX - Configure To Order (Factory Installed) or Field Installed

O = Configure To Order (Factory Installed)

X = Field Installed

SPECIFICATIONS		STANDARD EFFICIENCY - 15 TON 17.5 TON				
General Data		Nominal Tonnage	15 Ton	15 Ton	17.5 Ton	17.5 Ton
		Model Number	KCB180S4B	KCB180S4M	KCB210S4B	KCB210S4M
		Efficiency Type	Standard	Standard	Standard	Standard
		Blower Type	CAV (Constant Air Volume)	MSAV® (Multi-Stage Air Volume)	CAV (Constant Air Volume)	MSAV® (Multi-Stage Air Volume)
Cooling Performance	Gross Cooling Capacity - Btuh		182,000	182,000	206,000	206,000
	¹ Net Cooling Capacity - Btuh		176,000	176,000	200,000	200,000
	AHRI Rated Air Flow - cfm		6000	6000	5700	5700
	Total Unit Power - kW		16.0	16.0	18.2	18.0
	¹ EER (Btuh/Watt)		11.0	11.0	11.0	11.0
	² IEER (Btuh/Watt)		12.4	13.8	12.4	13.5
Refrigerant Charge	Refrigerant Type		R-410A	R-410A	R-410A	R-410A
	Environ™ Coil System	Circuit 1	5 lbs. 14 oz.	5 lbs. 14 oz.	6 lbs. 8 oz.	6 lbs. 8 oz.
		Circuit 2	5 lbs. 11 oz.	5 lbs. 11 oz.	6 lbs. 4 oz.	6 lbs. 4 oz.
		Circuit 3	5 lbs. 13 oz.	5 lbs. 13 oz.	6 lbs. 2 oz.	6 lbs. 2 oz.
	Conventional Fin/Tube Coil Option	Circuit 1	12 lbs. 7 oz.	12 lbs. 7 oz.	11 lbs. 0 oz.	11 lbs. 0 oz.
		Circuit 2	12 lbs. 0 oz.	12 lbs. 0 oz.	11 lbs. 0 oz.	11 lbs. 0 oz.
		Circuit 3	11 lbs. 3 oz.	11 lbs. 3 oz.	11 lbs. 0 oz.	11 lbs. 0 oz.
	Conventional Fin/Tube with Humiditrol® Option	Circuit 1	12 lbs. 10 oz.	12 lbs. 10 oz.	10 lbs. 10 oz.	10 lbs. 10 oz.
		Circuit 2	12 lbs. 10 oz.	12 lbs. 10 oz.	10 lbs. 15 oz.	10 lbs. 15 oz.
		Circuit 3	11 lbs. 12 oz.	11 lbs. 12 oz.	10 lbs. 7 oz.	10 lbs. 7 oz.
Electric Heat Available, see page 14			15-30-45-60 kW		15-30-45-60-90 kW	
Compressor Type (number)			Scroll (3)	Scroll (2)	Scroll (3)	Scroll (3)
Outdoor Coils Environ™ (Fin/Tube)	Net face area (total) - sq. ft.		41.4	41.4	41.4	41.4
	Number of rows		1 (2)	1 (2)	1 (2)	1 (2)
	Fins per inch		23 (20)	23 (20)	23 (20)	23 (20)
Outdoor Coil Fans	Motor - (No.) horsepower		(3) 1/3	(3) 1/3	(3) 1/3	(3) 1/3
	Motor rpm		1075	1075	1075	1075
	Total Motor watts		1100	1100	1100	1100
	Diameter - (No.) in.		(3) 24	(3) 24	(3) 24	(3) 24
	Number of blades		3	3	3	3
	Total Air volume - cfm		12,000	12,000	12,000	12,000
Indoor Coils	Net face area (total) - sq. ft.		21.4	21.4	21.4	21.4
	Tube diameter - in.		3/8	3/8	3/8	3/8
	Number of rows		3	3	4	4
	Fins per inch		14	14	14	14
	Drain connection - No. and size		(1) 1 in. FPT	(1) 1 in. FPT	(1) 1 in. FPT	(1) 1 in. FPT
	Expansion device type		Refrigerant Metering Orifice (RFC) - No Humiditrol® Option Balanced port TXV, removable head - Humiditrol® Option			
³ Indoor Blower and Drive Selection	Nominal motor output		3 hp, 5 hp, 7.5 hp			
	Maximum usable motor output (US Only)		3.45 hp, 5.75 hp, 8.62 hp			
	Motor - Drive kit number		3 hp Kit 1 535-725 rpm Kit 2 710-965 rpm 5 hp Kit 3 685-856 rpm Kit 4 850-1045 rpm Kit 5 945-1185 rpm 7.5 hp Kit 6 850-1045 rpm Kit 7 945-1185 rpm Kit 8 1045-1285 rpm			
	Blower wheel nominal diameter x width - in.		(2) 15 x 15	(2) 15 x 15	(2) 15 x 15	(2) 15 x 15
	Filters	Type of filter		Fiberglass, disposable		
Number and size - in.			(6) 24 x 24 x 2			
Electrical characteristics			208/230V, 460V or 575V - 60 hertz - 3 phase			

NOTE - Net capacity includes evaporator blower motor heat deduction. Gross capacity does not include evaporator blower motor heat deduction.

¹ AHRI Certified to AHRI Standard 340/360; 95°F outdoor air temperature and 80°F db/67°F wb entering evaporator air; minimum external duct static pressure.

² Integrated Energy Efficiency Ratio tested according to AHRI Standard 340/360.

³ Using total air volume and system static pressure requirements determine from blower performance tables rpm and motor output required. Maximum usable output of motors furnished are shown. In Canada, nominal motor output is also maximum usable motor output. If motors of comparable output are used, be sure to keep within the service factor limitations outlined on the motor nameplate.

NOTE – Units equipped with MSAV® (Multi-Stage Air Volume) are limited to a motor service factor of 1.0.

SPECIFICATIONS

STANDARD EFFICIENCY - 20 TON | 25 TON

General Data		Nominal Tonnage	20 Ton	20 Ton	25 Ton	25 Ton	
		Model Number	KCB240S4B	KCB240S4M	KCB300S4B	KCB300S4M	
		Efficiency Type	Standard	Standard	Standard	Standard	
		Blower Type	CAV (Constant Air Volume)	MSAV® (Multi-Stage Air Volume)	CAV (Constant Air Volume)	MSAV® (Multi-Stage Air Volume)	
Cooling Performance	Gross Cooling Capacity - Btuh		236,000	236,000	282,000	282,000	
	¹ Net Cooling Capacity - Btuh		230,000	230,000	270,000	270,000	
	AHRI Rated Air Flow - cfm		6000	6000	8400	8400	
	Total Unit Power - kW		20.9	20.9	25.7	25.7	
	¹ EER (Btuh/Watt)		11.0	11.0	10.5	10.5	
	² IEER (Btuh/Watt)		12.4	13.6	11.6	13.8	
Refrigerant Charge	Refrigerant Type		R-410A	R-410A	R-410A	R-410A	
	Environ™ Coil System	Circuit 1	7 lbs. 0 oz.	7 lbs. 0 oz.	6 lbs. 4 oz.	6 lbs. 4 oz.	
		Circuit 2	6 lbs. 15 oz.	6 lbs. 15 oz.	5 lbs. 10 oz.	5 lbs. 10 oz.	
		Circuit 3	6 lbs. 12 oz.	6 lbs. 12 oz.	6 lbs. 6 oz.	6 lbs. 6 oz.	
		Circuit 4	---	---	6 lbs. 0 oz.	6 lbs. 0 oz.	
	Conventional Fin Tube Coil Option	Circuit 1	14 lbs. 0 oz.	14 lbs. 0 oz.	10 lbs. 8 oz.	10 lbs. 8 oz.	
		Circuit 2	13 lbs. 12 oz.	13 lbs. 12 oz.	10 lbs. 0 oz.	10 lbs. 0 oz.	
		Circuit 3	12 lbs. 0 oz.	12 lbs. 0 oz.	9 lbs. 12 oz.	9 lbs. 12 oz.	
		Circuit 4	---	---	9 lbs. 12 oz.	9 lbs. 12 oz.	
	Conventional Fin/Tube with Humiditrol® Option	Circuit 1	14 lbs. 10 oz.	14 lbs. 10 oz.	12 lbs. 12 oz.	12 lbs. 12 oz.	
		Circuit 2	13 lbs. 4 oz.	13 lbs. 0 oz.	11 lbs. 12 oz.	11 lbs. 12 oz.	
		Circuit 3	12 lbs. 14 oz.	12 lbs. 14 oz.	9 lbs. 12 oz.	9 lbs. 12 oz.	
		Circuit 4	---	---	9 lbs. 12 oz.	9 lbs. 12 oz.	
	Electric Heat Available, see page 14			15-30-45-60-90 kW			
	Compressor Type (number)			Scroll (3)	Scroll (3)	Scroll (4)	Scroll (4)
	Outdoor Coils	Net face area (total) - sq. ft.		55.2	55.2	55.2	55.2
Environ™ Number of rows		1 (2)	1 (2)	1 (2)	1 (2)		
(Fin/Tube) Fins per inch		23 (20)	23 (20)	23 (20)	23 (20)		
Outdoor Coil Fans	Motor - (No.) horsepower		(4) 1/3	(4) 1/3	(6) 1/3	(6) 1/3	
	Motor rpm		1075	1075	1075	1075	
	Total Motor watts		1665	1665	1950	1950	
	Diameter - (No.) in.		(4) 24	(4) 24	(6) 24	(6) 24	
	Number of blades		3	3	3	3	
	Total Air volume - cfm		16,000	16,000	20,000	20,000	
Indoor Coils	Net face area (total) - sq. ft.		21.4	21.4	21.4	21.4	
	Tube diameter - in.		3/8	3/8	3/8	3/8	
	Number of rows		4	4	4	4	
	Fins per inch		14	14	14	14	
	Drain connection - No. and size		(1) 1 in. FPT	(1) 1 in. FPT	(1) 1 in. FPT	(1) 1 in. FPT	
	Expansion device type		Refrigerant Metering Orifice (RFC) - No Humiditrol® Option Balanced port TXV, removable head - Humiditrol® Option				
³ Indoor Blower and Drive Selection	Nominal motor output		5 hp, 7.5 hp, 10 hp				
	Maximum usable motor output (US Only)		5.75 hp, 8.62 hp, 11.5 hp				
	Motor - Drive kit number		5 hp Kit 3 685-856 rpm Kit 4 850-1045 rpm Kit 5 945-1185 rpm 7.5 hp Kit 6 850-1045 rpm Kit 7 945-1185 rpm Kit 8 1045-1285 rpm 10 hp Kit 7 945-1185 rpm Kit 10 1045-1285 rpm Kit 11 1135-1365 rpm				
	Blower wheel nominal diameter x width - in.		(2) 15 x 15	(2) 15 x 15	(2) 15 x 15	(2) 15 x 15	
	Filters	Type of filter		Fiberglass, disposable			
		Number and size - in.		(6) 24 x 24 x 2			
	Electrical characteristics			208/230V, 460V or 575V - 60 hertz - 3 phase			

NOTE - Net capacity includes evaporator blower motor heat deduction. Gross capacity does not include evaporator blower motor heat deduction.

¹ AHRI Certified to AHRI Standard 340/360; 95°F outdoor air temperature and 80°F db/67°F wb entering evaporator air; minimum external duct static pressure.

² Integrated Energy Efficiency Ratio tested according to AHRI Standard 340/360.

³ Using total air volume and system static pressure requirements determine from blower performance tables rpm and motor output required. Maximum usable output of motors furnished are shown. In Canada, nominal motor output is also maximum usable motor output. If motors of comparable output are used, be sure to keep within the service factor limitations outlined on the motor nameplate.

NOTE – Units equipped with MSAV® (Multi-Stage Air Volume) are limited to a motor service factor of 1.0.

SPECIFICATIONS

HIGH EFFICIENCY - 13 TON | 15 TON

General Data		Nominal Tonnage	13 Ton	13 Ton	15 Ton	15 Ton
		Model Number	KCA156H4B	KCA156H4M	KCA180H4B	KCA180H4M
		Efficiency Type	High	High	High	High
		Blower Type	CAV (Constant Air Volume)	MSAV® (Multi-Stage Air Volume)	CAV (Constant Air Volume)	MSAV® (Multi-Stage Air Volume)
Cooling Performance	Gross Cooling Capacity - Btuh		154,000	154,000	176,000	176,000
	¹ Net Cooling Capacity - Btuh		150,000	150,000	172,000	172,000
	AHRI Rated Air Flow - cfm		5000	5000	5250	5250
	Total Unit Power - kW		12.5	12.5	14.3	14.3
	¹ EER (Btuh/Watt)		12.0	12.0	12.0	12.0
	² IEER (Btuh/Watt)		13.2	14.1	13.5	13.7
Refrigerant Charge	Refrigerant Type		R-410A	R-410A	R-410A	R-410A
	Circuit 1		5 lbs. 12 oz.	5 lbs. 12 oz.	6 lbs. 0 oz.	6 lbs. 0 oz.
	Circuit 2		5 lbs. 4 oz.	5 lbs. 4 oz.	5 lbs. 10 oz.	5 lbs. 10 oz.
	Circuit 3		5 lbs. 10 oz.	5 lbs. 10 oz.	5 lbs. 14 oz.	5 lbs. 14 oz.
Electric Heat Available, see page 14			15-30-45-60 kW		15-30-45-60 kW	
Compressor Type (number)			Scroll (3)	Scroll (3)	Scroll (3)	Scroll (3)
Outdoor Coils	Net face area (total) - sq. ft.		41.4	41.4	55.2	55.2
	Number of rows		1	1	1	1
	Fins per inch		23	23	23	23
Outdoor Coil Fans	Motor - (No.) horsepower		(3) 1/3	(3) 1/3	(4) 1/3	(4) 1/3
	Motor rpm		1075	1075	1075	1075
	Total Motor watts		1100	1100	1500	1500
	Diameter - (No.) in.		(3) 24	(3) 24	(4) 24	(4) 24
	Number of blades		3	3	3	3
	Total Air volume - cfm		12000	12000	16,000	16,000
Indoor Coils	Net face area (total) - sq. ft.		21.4	21.4	21.4	21.4
	Tube diameter - in.		3/8	3/8	3/8	3/8
	Number of rows		3	3	3	3
	Fins per inch		14	14	14	14
	Drain connection - No. and size		(1) 1 in. FPT	(1) 1 in. FPT	(1) 1 in. FPT	(1) 1 in. FPT
Expansion device type			Balanced port TXV, removable head			
³ Indoor Blower and Drive Selection	Nominal motor output		2 hp, 3 hp, 5 hp		3 hp, 5 hp, 7.5 hp	
	Maximum usable motor output (US Only)		2.3 hp, 3.45 hp, 5.75 hp		3.45 hp, 5.75 hp, 8.62 hp	
	Motor - Drive kit number		2 hp Kit 1 535-725 rpm Kit 2 710-965 rpm 3 hp Kit 1 535-725 rpm Kit 2 710-965 rpm 5 hp Kit 3 685-856 rpm Kit 4 850-1045 rpm Kit 5 945-1185 rpm		3 hp Kit 1 535-725 rpm Kit 2 710-965 rpm 5 hp Kit 3 685-856 rpm Kit 4 850-1045 rpm Kit 5 945-1185 rpm 7.5 hp Kit 6 850-1045 rpm Kit 7 945-1185 rpm Kit 8 1045-1285 rpm	
Blower wheel nominal diameter x width - in.			(2) 15 x 15	(2) 15 x 15	(2) 15 x 15	(2) 15 x 15
Filters	Type of filter		Fiberglass, disposable			
	Number and size - in.		(6) 24 x 24 x 2			
Electrical characteristics			208/230V, 460V or 575V - 60 hertz - 3 phase			

NOTE - Net capacity includes evaporator blower motor heat deduction. Gross capacity does not include evaporator blower motor heat deduction.

¹ AHRI Certified to AHRI Standard 340/360; 95°F outdoor air temperature and 80°F db/67°F wb entering evaporator air; minimum external duct static pressure.

² Integrated Energy Efficiency Ratio tested according to AHRI Standard 340/360.

³ Using total air volume and system static pressure requirements determine from blower performance tables rpm and motor output required. Maximum usable output of motors furnished are shown. In Canada, nominal motor output is also maximum usable motor output. If motors of comparable output are used, be sure to keep within the service factor limitations outlined on the motor nameplate.

NOTE – Units equipped with MSAV® (Multi-Stage Air Volume) are limited to a motor service factor of 1.0.

SPECIFICATIONS

HIGH EFFICIENCY - 17.5 TON | 20 TON

General Data		Nominal Tonnage	17.5 Ton	17.5 Ton	20 Ton	20 Ton
		Model Number	KCA210H4B	KCA210H4M	KCA240H4B	KCA240H4M
		Efficiency Type	High	High	High	High
		Blower Type	CAV (Constant Air Volume)	MSAV® (Multi-Stage Air Volume)	CAV (Constant Air Volume)	MSAV® (Multi-Stage Air Volume)
Cooling Performance	Gross Cooling Capacity - Btuh		204,000	204,000	238,000	238,000
	¹ Net Cooling Capacity - Btuh		194,000	194,000	230,000	230,000
	AHRI Rated Air Flow - cfm		6125	6125	6400	6400
	Total Unit Power - kW		16.5	16.5	19.2	19.2
	¹ EER (Btuh/Watt)		12.0	12.0	12.0	12.0
	² IEER (Btuh/Watt)		13.0	14.0	13.2	14.5
Refrigerant Charge	Refrigerant Type		R-410A	R-410A	R-410A	R-410A
	Circuit 1		6 lbs. 12 oz.	6 lbs. 12 oz.	6 lbs. 4 oz.	6 lbs. 4 oz.
	Circuit 2		6 lbs. 14 oz.	6 lbs. 14 oz.	6 lbs. 2 oz.	6 lbs. 2 oz.
	Circuit 3		6 lbs. 14 oz.	6 lbs. 14 oz.	5 lbs. 14 oz.	5 lbs. 14 oz.
	Circuit 4		- - -	- - -	5 lbs. 6 oz.	5 lbs. 6 oz.
Electric Heat Available, see page 14			15-30-45-60-90 kW			
Compressor Type (number)			Scroll (3)	Scroll (3)	Scroll (4)	Scroll (4)
Outdoor Coils	Net face area (total) - sq. ft.		55.2	55.2	55.2	55.2
	Number of rows		1	1	1	1
	Fins per inch		23	23	23	23
Outdoor Coil Fans	Motor - (No.) horsepower		(6) 1/3	(6) 1/3	(6) 1/3	(6) 1/3
	Motor rpm		1075	1075	1075	1075
	Total Motor watts		1950	1950	1950	1950
	Diameter - (No.) in.		(6) 24	(6) 24	(6) 24	(6) 24
	Number of blades		3	3	3	3
	Total Air volume - cfm		20,000	20,000	20,000	20,000
Indoor Coils	Net face area (total) - sq. ft.		21.4	21.4	21.4	21.4
	Tube diameter - in.		3/8	3/8	3/8	3/8
	Number of rows		4	4	4	4
	Fins per inch		14	14	14	14
	Drain connection - No. and size		(1) 1 in. FPT	(1) 1 in. FPT	(1) 1 in. FPT	(1) 1 in. FPT
Expansion device type			Balanced port TXV, removable head			
³ Indoor Blower and Drive Selection	Nominal motor output		3 hp, 5 hp, 7.5 hp		5 hp, 7.5 hp, 10hp	
	Maximum usable motor output (US Only)		3.45 hp, 5.75 hp, 8.62 hp		5.75 hp, 8.62 hp, 11.5 hp	
	Motor - Drive kit number		3 hp Kit 1 535-725 rpm Kit 2 710-965 rpm 5 hp Kit 3 685-856 rpm Kit 4 850-1045 rpm Kit 5 945-1185 rpm 7.5 hp Kit 6 850-1045 rpm Kit 7 945-1185 rpm Kit 8 1045-1285 rpm		5 hp Kit 3 685-856 rpm Kit 4 850-1045 rpm Kit 5 945-1185 rpm 7.5 hp Kit 6 850-1045 rpm Kit 7 945-1185 rpm Kit 8 1045-1285 rpm 10 hp Kit 7 945-1185 rpm Kit 10 1045-1285 rpm Kit 11 1135-1365 rpm	
Blower wheel nominal diameter x width - in.			(2) 15 x 15	(2) 15 x 15	(2) 15 x 15	(2) 15 x 15
Filters	Type of filter		Fiberglass, disposable			
	Number and size - in.		(6) 24 x 24 x 2			
Electrical characteristics			208/230V, 460V or 575V - 60 hertz - 3 phase			

NOTE - Net capacity includes evaporator blower motor heat deduction. Gross capacity does not include evaporator blower motor heat deduction.

¹ AHRI Certified to AHRI Standard 340/360; 95°F outdoor air temperature and 80°F db/67°F wb entering evaporator air; minimum external duct static pressure.

² Integrated Energy Efficiency Ratio tested according to AHRI Standard 340/360.

³ Using total air volume and system static pressure requirements determine from blower performance tables rpm and motor output required. Maximum usable output of motors furnished are shown. In Canada, nominal motor output is also maximum usable motor output. If motors of comparable output are used, be sure to keep within the service factor limitations outlined on the motor nameplate.

NOTE – Units equipped with MSAV® (Multi-Stage Air Volume) are limited to a motor service factor of 1.0.

RATINGS

STANDARD EFFICIENCY

NOTE - For Temperatures and Capacities not shown in tables, see bulletin - Cooling Unit Rating Table Correction Factor Data in Miscellaneous Engineering Data section.

15 TON STANDARD EFFICIENCY KCB180S4B (1ST STAGE) - CONSTANT AIR VOLUME

Entering Wet Bulb Temperature	Total Air Volume	Outdoor Air Temperature Entering Outdoor Coil																			
		65°F					75°F					85°F					95°F				
		Total Cool Cap.	Comp. Motor Input	Sensible To Total Ratio (S/T)			Total Cool Cap.	Comp. Motor Input	Sensible To Total Ratio (S/T)			Total Cool Cap.	Comp. Motor Input	Sensible To Total Ratio (S/T)			Total Cool Cap.	Comp. Motor Input	Sensible To Total Ratio (S/T)		
				Dry Bulb					Dry Bulb					Dry Bulb					Dry Bulb		
cfm	kBtuh	kW	75°F	80°F	85°F	kBtuh	kW	75°F	80°F	85°F	kBtuh	kW	75°F	80°F	85°F	kBtuh	kW	75°F	80°F	85°F	
63°F	4800	127	5.43	0.66	0.78	0.9	122.2	6.16	0.67	0.79	0.92	116.8	6.92	0.68	0.81	0.94	111.2	7.77	0.69	0.83	0.97
	6000	134	5.48	0.7	0.84	0.97	128.7	6.2	0.71	0.85	0.99	123	6.98	0.72	0.88	1	116.9	7.83	0.74	0.9	1
	7200	139	5.52	0.73	0.89	1	133.5	6.24	0.75	0.92	1	127.5	7.01	0.77	0.94	1	121.1	7.86	0.79	0.97	1
67°F	4800	134	5.48	0.53	0.64	0.74	128.9	6.2	0.54	0.65	0.76	123.5	6.98	0.54	0.66	0.77	117.6	7.83	0.55	0.67	0.79
	6000	141.5	5.54	0.55	0.67	0.8	135.9	6.26	0.56	0.68	0.82	130	7.03	0.56	0.7	0.84	123.5	7.88	0.58	0.71	0.86
	7200	146.8	5.58	0.58	0.71	0.86	140.8	6.3	0.58	0.72	0.88	134.6	7.07	0.59	0.74	0.9	127.8	7.92	0.6	0.76	0.93
71°F	4800	140.7	5.53	0.41	0.52	0.61	135.3	6.25	0.42	0.52	0.62	129.7	7.03	0.41	0.53	0.63	124.1	7.89	0.42	0.53	0.64
	6000	148.6	5.6	0.42	0.54	0.65	142.7	6.31	0.42	0.54	0.66	136.6	7.09	0.42	0.55	0.68	130	7.95	0.43	0.56	0.69
	7200	154.1	5.65	0.43	0.56	0.69	148	6.36	0.43	0.57	0.7	141.3	7.13	0.43	0.58	0.72	134.4	7.98	0.44	0.59	0.74

15 TON STANDARD EFFICIENCY KCB180S4B (2ND STAGE) - CONSTANT AIR VOLUME

Entering Wet Bulb Temperature	Total Air Volume	Outdoor Air Temperature Entering Outdoor Coil																			
		85°F					95°F					105°F					115°F				
		Total Cool Cap.	Comp. Motor Input	Sensible To Total Ratio (S/T)			Total Cool Cap.	Comp. Motor Input	Sensible To Total Ratio (S/T)			Total Cool Cap.	Comp. Motor Input	Sensible To Total Ratio (S/T)			Total Cool Cap.	Comp. Motor Input	Sensible To Total Ratio (S/T)		
				Dry Bulb					Dry Bulb					Dry Bulb					Dry Bulb		
cfm	kBtuh	kW	75°F	80°F	85°F	kBtuh	kW	75°F	80°F	85°F	kBtuh	kW	75°F	80°F	85°F	kBtuh	kW	75°F	80°F	85°F	
63°F	4800	170.7	11.45	0.68	0.83	0.99	162.4	12.84	0.7	0.86	1	153.5	14.39	0.71	0.89	1	144.4	16.18	0.73	0.93	1
	6000	178.7	11.54	0.73	0.92	1	169.7	12.93	0.75	0.95	1	160.4	14.48	0.78	0.98	1	151.2	16.28	0.81	1	1
	7200	184.7	11.61	0.79	0.99	1	175.6	13	0.81	1	1	166.8	14.57	0.85	1	1	158.2	16.39	0.88	1	1
67°F	4800	180.4	11.56	0.54	0.66	0.79	171.4	12.95	0.55	0.67	0.82	162.3	14.51	0.56	0.69	0.85	152.8	16.29	0.57	0.71	0.88
	6000	188.6	11.66	0.56	0.71	0.88	179	13.05	0.58	0.72	0.91	169.1	14.6	0.59	0.75	0.95	159	16.4	0.6	0.78	0.98
	7200	194.5	11.73	0.59	0.76	0.96	184.2	13.11	0.61	0.79	0.99	173.7	14.67	0.62	0.82	1	163.2	16.46	0.64	0.86	1
71°F	4800	189.5	11.68	0.41	0.53	0.64	180.4	13.06	0.41	0.53	0.65	170.9	14.63	0.41	0.54	0.67	161.2	16.43	0.41	0.55	0.69
	6000	198.3	11.78	0.41	0.55	0.68	188.4	13.17	0.42	0.56	0.7	178	14.74	0.43	0.58	0.72	167.7	16.53	0.43	0.59	0.75
	7200	204.4	11.86	0.43	0.58	0.73	193.8	13.24	0.43	0.6	0.76	183.1	14.81	0.44	0.61	0.79	172	16.6	0.45	0.63	0.83

15 TON STANDARD EFFICIENCY KCB180S4M (1ST STAGE) - MSAV® (Multi-Stage Air Volume) SUPPLY AIR BLOWER

Entering Wet Bulb Temperature	Total Air Volume	Outdoor Air Temperature Entering Outdoor Coil																			
		65°F					75°F					85°F					95°F				
		Total Cool Cap.	Comp. Motor Input	Sensible To Total Ratio (S/T)			Total Cool Cap.	Comp. Motor Input	Sensible To Total Ratio (S/T)			Total Cool Cap.	Comp. Motor Input	Sensible To Total Ratio (S/T)			Total Cool Cap.	Comp. Motor Input	Sensible To Total Ratio (S/T)		
				Dry Bulb					Dry Bulb					Dry Bulb					Dry Bulb		
cfm	kBtuh	kW	75°F	80°F	85°F	kBtuh	kW	75°F	80°F	85°F	kBtuh	kW	75°F	80°F	85°F	kBtuh	kW	75°F	80°F	85°F	
63°F	3500	87	4.84	0.65	0.75	0.84	82.9	5.36	0.65	0.75	0.85	78.3	5.9	0.65	0.76	0.85	73.6	6.51	0.65	0.76	0.86
	4000	91	4.89	0.68	0.77	0.87	86.7	5.38	0.67	0.78	0.87	82	5.93	0.67	0.78	0.89	77.2	6.57	0.67	0.79	0.9
	4500	94.5	4.92	0.69	0.79	0.89	90	5.41	0.69	0.8	0.9	85.1	5.97	0.69	0.8	0.92	80	6.6	0.69	0.81	0.93
67°F	3500	92.5	4.89	0.54	0.64	0.72	87.9	5.39	0.54	0.63	0.72	83	5.95	0.53	0.63	0.73	78	6.57	0.52	0.63	0.73
	4000	96.2	4.93	0.55	0.65	0.74	91.5	5.44	0.54	0.65	0.75	86.6	5.98	0.54	0.65	0.75	81.5	6.6	0.53	0.65	0.76
	4500	99.6	4.97	0.56	0.67	0.76	94.8	5.46	0.55	0.67	0.77	89.8	6.02	0.55	0.67	0.77	84.4	6.65	0.54	0.67	0.78
71°F	3500	97.6	4.93	0.43	0.53	0.61	92.9	5.43	0.42	0.52	0.61	87.9	5.98	0.41	0.51	0.61	82.8	6.63	0.4	0.51	0.61
	4000	101.4	4.97	0.43	0.54	0.62	96.6	5.48	0.43	0.53	0.63	91.5	6.03	0.42	0.52	0.63	86.2	6.67	0.4	0.52	0.63
	4500	104.8	5.02	0.44	0.54	0.64	100	5.53	0.42	0.54	0.64	94.7	6.08	0.41	0.55	0.65	88.7	6.7	0.41	0.53	0.65

15 TON STANDARD EFFICIENCY KCB180S4M (2ND STAGE) - MSAV® (Multi-Stage Air Volume) SUPPLY AIR BLOWER

Entering Wet Bulb Temperature	Total Air Volume	Outdoor Air Temperature Entering Outdoor Coil																			
		85°F					95°F					105°F					115°F				
		Total Cool Cap.	Comp. Motor Input	Sensible To Total Ratio (S/T)			Total Cool Cap.	Comp. Motor Input	Sensible To Total Ratio (S/T)			Total Cool Cap.	Comp. Motor Input	Sensible To Total Ratio (S/T)			Total Cool Cap.	Comp. Motor Input	Sensible To Total Ratio (S/T)		
				Dry Bulb					Dry Bulb					Dry Bulb					Dry Bulb		
cfm	kBtuh	kW	75°F	80°F	85°F	kBtuh	kW	75°F	80°F	85°F	kBtuh	kW	75°F	80°F	85°F	kBtuh	kW	75°F	80°F	85°F	
63°F	4800	175.2	11.96	0.73	0.85	0.96	164.0	13.20	0.74	0.87	0.98	152.1	14.65	0.75	0.89	0.99	139.3	16.35	0.76	0.91	1.00
	6000	184.8	12.1	0.78	0.91	1.00	172.9	13.34	0.79	0.93	1.00	160.4	14.8	0.8	0.95	1.00	147.0	16.5	0.82	0.98	1.00
	7200	192	12.19	0.82	0.96	1.00	179.8	13.45	0.83	0.98	1.00	166.8	14.91	0.85	1.00	1.00	153.5	16.6	0.87	1.00	1.00
67°F	4800	186.3	12.11	0.58	0.71	0.83	174.7	13.36	0.57	0.71	0.84	162.5	14.83	0.57	0.73	0.86	149.2	16.54	0.57	0.74	0.88
	6000	196.4	12.27	0.60	0.76	0.89	184.1	13.52	0.60	0.77	0.90	170.9	14.96	0.61	0.78	0.92	157.0	16.69	0.61	0.80	0.95
	7200	203.6	12.35	0.64	0.8	0.94	190.7	13.61	0.64	0.82	0.96	176.9	15.09	0.65	0.83	0.98	162.1	16.77	0.66	0.85	1.00
71°F	4800	197.2	12.25	0.43	0.56	0.68	185.6	13.53	0.42	0.56	0.69	172.7	14.98	0.41	0.56	0.70	159.1	16.69	0.40	0.56	0.72
	6000	207.8	12.41	0.44	0.59	0.74	194.7	13.66	0.43	0.60	0.75	181.6	15.17	0.43	0.6	0.76	166.9	16.87	0.42	0.61	0.78
	7200	215.2	12.54	0.45	0.63	0.78	201.9	13.80	0.45	0.63	0.80	187.7	15.29	0.45	0.64	0.82	172.2	16.98	0.45	0.65	0.84

RATINGS

STANDARD EFFICIENCY

NOTE - For Temperatures and Capacities not shown in tables, see bulletin - Cooling Unit Rating Table Correction Factor Data in Miscellaneous Engineering Data section.

17.5 TON STANDARD EFFICIENCY KCB210S4B (1ST STAGE) - CONSTANT AIR VOLUME

Entering Wet Bulb Temperature	Total Air Volume	Outdoor Air Temperature Entering Outdoor Coil																			
		65°F					75°F					85°F					95°F				
		Total Cool Cap.	Comp. Motor Input	Sensible To Total Ratio (S/T)			Total Cool Cap.	Comp. Motor Input	Sensible To Total Ratio (S/T)			Total Cool Cap.	Comp. Motor Input	Sensible To Total Ratio (S/T)			Total Cool Cap.	Comp. Motor Input	Sensible To Total Ratio (S/T)		
				Dry Bulb					Dry Bulb					Dry Bulb					Dry Bulb		
cfm	kBtuh	kW	75°F	80°F	85°F	kBtuh	kW	75°F	80°F	85°F	kBtuh	kW	75°F	80°F	85°F	kBtuh	kW	75°F	80°F	85°F	
63°F	5600	160.7	6.69	0.64	0.77	0.92	150.3	7.53	0.64	0.79	0.94	139.6	8.47	0.64	0.8	0.97	128.1	9.52	0.65	0.82	0.99
	7000	170.4	6.76	0.68	0.85	0.99	159.5	7.61	0.69	0.87	1	147.9	8.54	0.7	0.9	1	136.3	9.61	0.72	0.93	1
	8400	178	6.82	0.74	0.93	1	166.8	7.67	0.75	0.95	1	154.9	8.61	0.77	0.98	1	142.9	9.68	0.79	0.99	1
67°F	5600	172.6	6.77	0.51	0.62	0.74	161.8	7.63	0.5	0.62	0.75	150.6	8.57	0.5	0.62	0.76	138.9	9.64	0.49	0.63	0.78
	7000	182.7	6.86	0.53	0.66	0.81	171.3	7.71	0.54	0.67	0.83	159.1	8.65	0.53	0.68	0.86	146.6	9.72	0.53	0.69	0.89
	8400	189.7	6.92	0.56	0.71	0.89	177.9	7.78	0.57	0.73	0.92	165	8.72	0.57	0.74	0.95	151.9	9.78	0.57	0.77	0.98
71°F	5600	184.7	6.87	0.39	0.5	0.6	173.4	7.74	0.38	0.49	0.6	161.6	8.68	0.37	0.49	0.61	149.3	9.75	0.35	0.49	0.61
	7000	194.7	6.96	0.4	0.52	0.64	182.9	7.83	0.39	0.53	0.65	170.1	8.78	0.39	0.53	0.66	157.2	9.85	0.38	0.53	0.68
	8400	202.1	7.04	0.42	0.55	0.69	189.8	7.91	0.41	0.56	0.7	176.6	8.85	0.4	0.56	0.72	162.6	9.92	0.4	0.56	0.74

17.5 TON STANDARD EFFICIENCY KCB210S4B (2ND STAGE) - CONSTANT AIR VOLUME

Entering Wet Bulb Temperature	Total Air Volume	Outdoor Air Temperature Entering Outdoor Coil																			
		85°F					95°F					105°F					115°F				
		Total Cool Cap.	Comp. Motor Input	Sensible To Total Ratio (S/T)			Total Cool Cap.	Comp. Motor Input	Sensible To Total Ratio (S/T)			Total Cool Cap.	Comp. Motor Input	Sensible To Total Ratio (S/T)			Total Cool Cap.	Comp. Motor Input	Sensible To Total Ratio (S/T)		
				Dry Bulb					Dry Bulb					Dry Bulb					Dry Bulb		
cfm	kBtuh	kW	75°F	80°F	85°F	kBtuh	kW	75°F	80°F	85°F	kBtuh	kW	75°F	80°F	85°F	kBtuh	kW	75°F	80°F	85°F	
63°F	5600	205.4	13.32	0.66	0.82	0.98	188.3	14.98	0.66	0.85	0.99	170.7	16.91	0.68	0.88	1	152.7	19.17	0.69	0.92	1
	7000	217.4	13.46	0.71	0.92	1	199.6	15.13	0.73	0.95	1	181.9	17.06	0.75	0.98	1	164.3	19.34	0.78	0.99	1
	8400	227.5	13.59	0.78	0.99	1	209.9	15.28	0.81	1	1	192.6	17.21	0.84	1	1	174.7	19.49	0.88	1	1
67°F	5600	221.3	13.51	0.51	0.64	0.78	203.6	15.18	0.5	0.65	0.81	185	17.09	0.5	0.66	0.84	166.2	19.36	0.5	0.67	0.88
	7000	233.1	13.66	0.54	0.7	0.89	214.2	15.33	0.54	0.71	0.92	194.8	17.25	0.54	0.73	0.95	174.7	19.48	0.55	0.76	0.98
	8400	241.4	13.77	0.58	0.76	0.97	221.7	15.43	0.58	0.79	0.99	201.3	17.34	0.59	0.82	1	180.8	19.59	0.6	0.86	1
71°F	5600	237.2	13.72	0.37	0.5	0.62	218.4	15.39	0.36	0.5	0.63	199.4	17.31	0.35	0.5	0.64	180	19.57	0.33	0.49	0.65
	7000	249	13.88	0.39	0.54	0.68	229.5	15.55	0.38	0.54	0.69	209.2	17.45	0.37	0.54	0.71	188.5	19.7	0.35	0.55	0.74
	8400	257.7	13.99	0.41	0.58	0.74	236.9	15.66	0.4	0.58	0.77	215.7	17.57	0.39	0.59	0.8	194.6	19.8	0.38	0.6	0.84

17.5 TON STANDARD EFFICIENCY KCB210S4M (1ST STAGE) - MSAV® (Multi-Stage Air Volume) SUPPLY AIR BLOWER

Entering Wet Bulb Temperature	Total Air Volume	Outdoor Air Temperature Entering Outdoor Coil																			
		65°F					75°F					85°F					95°F				
		Total Cool Cap.	Comp. Motor Input	Sensible To Total Ratio (S/T)			Total Cool Cap.	Comp. Motor Input	Sensible To Total Ratio (S/T)			Total Cool Cap.	Comp. Motor Input	Sensible To Total Ratio (S/T)			Total Cool Cap.	Comp. Motor Input	Sensible To Total Ratio (S/T)		
				Dry Bulb					Dry Bulb					Dry Bulb					Dry Bulb		
cfm	kBtuh	kW	75°F	80°F	85°F	kBtuh	kW	75°F	80°F	85°F	kBtuh	kW	75°F	80°F	85°F	kBtuh	kW	75°F	80°F	85°F	
63°F	4000	134.7	6.84	0.67	0.77	0.85	127.7	7.65	0.67	0.77	0.86	120.2	8.52	0.67	0.77	0.87	112.2	9.54	0.67	0.78	0.89
	4750	143.1	6.89	0.69	0.79	0.89	135.6	7.7	0.69	0.8	0.9	127.4	8.58	0.69	0.81	0.91	118.9	9.6	0.69	0.82	0.93
	5500	149.6	6.92	0.71	0.82	0.93	141.8	7.73	0.71	0.83	0.94	133.2	8.63	0.72	0.84	0.95	124.3	9.65	0.72	0.85	0.97
67°F	4000	143.8	6.88	0.54	0.64	0.73	136.6	7.69	0.54	0.64	0.74	128.9	8.59	0.53	0.64	0.74	120.3	9.6	0.53	0.64	0.75
	4750	152.4	6.93	0.56	0.67	0.76	144.8	7.76	0.55	0.67	0.77	136.1	8.65	0.55	0.67	0.78	127.1	9.68	0.54	0.67	0.79
	5500	159.3	6.98	0.57	0.69	0.79	150.9	7.81	0.57	0.69	0.8	141.9	8.71	0.57	0.69	0.81	132.4	9.74	0.56	0.7	0.82
71°F	4000	153.7	6.94	0.43	0.52	0.62	146	7.75	0.42	0.52	0.62	137.6	8.66	0.4	0.51	0.62	128.6	9.69	0.39	0.51	0.62
	4750	162.1	6.99	0.44	0.54	0.64	153.8	7.82	0.43	0.54	0.64	144.8	8.74	0.41	0.53	0.64	135.3	9.77	0.41	0.53	0.65
	5500	168.9	7.05	0.44	0.56	0.66	159.9	7.88	0.43	0.56	0.67	150.7	8.8	0.43	0.55	0.67	140.3	9.83	0.42	0.55	0.68

17.5 TON STANDARD EFFICIENCY KCB210S4M (2ND STAGE) - MSAV® (Multi-Stage Air Volume) SUPPLY AIR BLOWER

Entering Wet Bulb Temperature	Total Air Volume	Outdoor Air Temperature Entering Outdoor Coil																			
		85°F					95°F					105°F					115°F				
		Total Cool Cap.	Comp. Motor Input	Sensible To Total Ratio (S/T)			Total Cool Cap.	Comp. Motor Input	Sensible To Total Ratio (S/T)			Total Cool Cap.	Comp. Motor Input	Sensible To Total Ratio (S/T)			Total Cool Cap.	Comp. Motor Input	Sensible To Total Ratio (S/T)		
				Dry Bulb					Dry Bulb					Dry Bulb					Dry Bulb		
cfm	kBtuh	kW	75°F	80°F	85°F	kBtuh	kW	75°F	80°F	85°F	kBtuh	kW	75°F	80°F	85°F	kBtuh	kW	75°F	80°F	85°F	
63°F	5600	202.9	13.37	0.74	0.88	0.98	188.5	14.96	0.75	0.89	1.00	173.7	16.82	0.76	0.92	1.00	158.5	19.09	0.78	0.94	1.00
	7000	213.9	13.51	0.8	0.94	1.00	198.9	15.10	0.81	0.96	1.00	183.1	16.95	0.83	0.98	1.00	167.9	19.21	0.85	0.99	1.00
	8400	222.4	13.61	0.84	0.99	1.00	207.0	15.21	0.86	1.00	1.00	191.6	17.09	0.88	1.00	1.00	176.7	19.35	0.9	1.00	1.00
67°F	5600	216.5	13.53	0.58	0.72	0.85	201.5	15.13	0.58	0.73	0.86	186.0	16.99	0.58	0.74	0.88	169.9	19.23	0.58	0.76	0.91
	7000	227.9	13.68	0.61	0.78	0.91	211.8	15.28	0.62	0.79	0.93	195.4	17.15	0.62	0.81	0.96	178.3	19.38	0.63	0.83	0.98
	8400	235.8	13.78	0.65	0.82	0.96	219.0	15.39	0.65	0.84	0.98	201.7	17.25	0.66	0.86	1.00	184.6	19.49	0.67	0.89	1.00
71°F	5600	230.0	13.71	0.43	0.57	0.70	214.3	15.31	0.42	0.57	0.71	198.0	17.18	0.41	0.57	0.72	181.6	19.43	0.40	0.57	0.74
	7000	241.3	13.86	0.44	0.6	0.76	224.7	15.48	0.44	0.61	0.77	207.6	17.34	0.43	0.62	0.79	190.2	19.57	0.43	0.62	0.81
	8400	249.4	13.97	0.46	0.64	0.81	231.9	15.57	0.46	0.65	0.82	214.2	17.45	0.45	0.66	0.84	195.9	19.68	0.45	0.67	0.87

RATINGS

STANDARD EFFICIENCY

NOTE - For Temperatures and Capacities not shown in tables, see bulletin - Cooling Unit Rating Table Correction Factor Data in Miscellaneous Engineering Data section.

20 TON STANDARD EFFICIENCY KCB240S4B (1ST STAGE) - CONSTANT AIR VOLUME

Entering Wet Bulb Temperature	Total Air Volume	Outdoor Air Temperature Entering Outdoor Coil																			
		65°F					75°F					85°F					95°F				
		Total Cool Cap.	Comp. Motor Input	Sensible To Total Ratio (S/T)			Total Cool Cap.	Comp. Motor Input	Sensible To Total Ratio (S/T)			Total Cool Cap.	Comp. Motor Input	Sensible To Total Ratio (S/T)			Total Cool Cap.	Comp. Motor Input	Sensible To Total Ratio (S/T)		
				Dry Bulb					Dry Bulb					Dry Bulb					Dry Bulb		
cfm	kBtuh	kW	75°F	80°F	85°F	kBtuh	kW	75°F	80°F	85°F	kBtuh	kW	75°F	80°F	85°F	kBtuh	kW	75°F	80°F	85°F	
63°F	6400	171.1	7.51	0.7	0.83	0.95	162.6	8.34	0.71	0.84	0.97	153.5	9.27	0.72	0.86	0.98	143.7	10.29	0.73	0.88	1
	8000	180.1	7.55	0.75	0.89	1	171	8.39	0.76	0.91	1	161.5	9.31	0.77	0.93	1	151.6	10.34	0.79	0.96	1
	9600	187.2	7.57	0.79	0.95	1	178	8.42	0.81	0.97	1	168	9.35	0.83	0.99	1	157.1	10.38	0.85	1	1
67°F	6400	182.3	7.55	0.56	0.68	0.79	173.6	8.39	0.56	0.69	0.81	163.7	9.33	0.56	0.7	0.82	153.5	10.36	0.56	0.7	0.84
	8000	191.4	7.59	0.58	0.72	0.86	181.9	8.44	0.59	0.73	0.88	171.7	9.37	0.6	0.75	0.9	160.3	10.4	0.61	0.76	0.92
	9600	198.2	7.62	0.62	0.78	0.92	187.9	8.47	0.63	0.78	0.94	177.3	9.41	0.63	0.8	0.97	165.9	10.44	0.64	0.83	0.99
71°F	6400	193.6	7.6	0.43	0.55	0.66	184.4	8.45	0.43	0.55	0.66	174	9.39	0.42	0.55	0.67	163.1	10.42	0.42	0.55	0.69
	8000	202.8	7.63	0.44	0.57	0.71	192.8	8.5	0.43	0.58	0.71	182.2	9.44	0.43	0.59	0.73	171	10.47	0.43	0.6	0.75
	9600	210	7.67	0.45	0.61	0.75	199.2	8.54	0.45	0.62	0.77	188	9.48	0.45	0.62	0.78	175.9	10.52	0.45	0.63	0.81

20 TON STANDARD EFFICIENCY KCB240S4B (2ND STAGE) - CONSTANT AIR VOLUME

Entering Wet Bulb Temperature	Total Air Volume	Outdoor Air Temperature Entering Outdoor Coil																			
		85°F					95°F					105°F					115°F				
		Total Cool Cap.	Comp. Motor Input	Sensible To Total Ratio (S/T)			Total Cool Cap.	Comp. Motor Input	Sensible To Total Ratio (S/T)			Total Cool Cap.	Comp. Motor Input	Sensible To Total Ratio (S/T)			Total Cool Cap.	Comp. Motor Input	Sensible To Total Ratio (S/T)		
				Dry Bulb					Dry Bulb					Dry Bulb					Dry Bulb		
cfm	kBtuh	kW	75°F	80°F	85°F	kBtuh	kW	75°F	80°F	85°F	kBtuh	kW	75°F	80°F	85°F	kBtuh	kW	75°F	80°F	85°F	
63°F	6400	237.6	15.43	0.73	0.88	0.99	221.7	17.11	0.74	0.9	1	205.4	19.02	0.76	0.93	1	189.5	21.25	0.77	0.95	1
	8000	249.7	15.56	0.79	0.95	1	233.1	17.24	0.81	0.97	1	216.7	19.16	0.83	0.99	1	201.2	21.39	0.85	0.99	1
	9600	259.9	15.66	0.85	0.99	1	243.8	17.36	0.87	1	1	227	19.28	0.89	1	1	211.1	21.5	0.92	1	1
67°F	6400	253.3	15.6	0.57	0.71	0.85	236.4	17.28	0.57	0.72	0.87	219.2	19.2	0.58	0.74	0.89	202.3	21.41	0.58	0.75	0.92
	8000	264.7	15.73	0.61	0.77	0.93	246.7	17.41	0.61	0.79	0.95	228.9	19.33	0.62	0.81	0.97	210.9	21.52	0.63	0.83	0.98
	9600	273.1	15.82	0.64	0.83	0.98	254.7	17.51	0.65	0.85	0.99	235.5	19.41	0.66	0.87	1	217.6	21.61	0.67	0.9	1
71°F	6400	268.7	15.76	0.42	0.55	0.69	251.5	17.46	0.42	0.56	0.7	233.7	19.37	0.41	0.57	0.72	216.1	21.58	0.4	0.57	0.73
	8000	281	15.91	0.44	0.6	0.75	262.3	17.6	0.43	0.61	0.77	243.3	19.5	0.43	0.61	0.79	224.4	21.7	0.43	0.62	0.81
	9600	289.2	16.01	0.46	0.64	0.81	269.3	17.7	0.45	0.64	0.83	250	19.6	0.45	0.66	0.86	231.1	21.79	0.45	0.68	0.88

20 TON STANDARD EFFICIENCY KCB240S4M (1ST STAGE) - MSAV® (Multi-Stage Air Volume) SUPPLY AIR BLOWER

Entering Wet Bulb Temperature	Total Air Volume	Outdoor Air Temperature Entering Outdoor Coil																			
		65°F					75°F					85°F					95°F				
		Total Cool Cap.	Comp. Motor Input	Sensible To Total Ratio (S/T)			Total Cool Cap.	Comp. Motor Input	Sensible To Total Ratio (S/T)			Total Cool Cap.	Comp. Motor Input	Sensible To Total Ratio (S/T)			Total Cool Cap.	Comp. Motor Input	Sensible To Total Ratio (S/T)		
				Dry Bulb					Dry Bulb					Dry Bulb					Dry Bulb		
cfm	kBtuh	kW	75°F	80°F	85°F	kBtuh	kW	75°F	80°F	85°F	kBtuh	kW	75°F	80°F	85°F	kBtuh	kW	75°F	80°F	85°F	
63°F	4500	150.3	7.71	0.64	0.75	0.84	142.4	8.51	0.64	0.75	0.85	133.8	9.39	0.64	0.75	0.87	125	10.4	0.64	0.76	0.88
	5500	161	7.74	0.67	0.79	0.9	152.4	8.54	0.67	0.79	0.91	143	9.43	0.67	0.8	0.92	133.3	10.44	0.68	0.81	0.94
	6500	169	7.75	0.7	0.82	0.94	159.8	8.56	0.71	0.84	0.96	149.9	9.46	0.7	0.85	0.98	139.7	10.48	0.71	0.86	0.99
67°F	4500	161.1	7.73	0.53	0.62	0.71	152.8	8.54	0.52	0.62	0.72	144	9.43	0.51	0.62	0.72	134.5	10.44	0.5	0.62	0.73
	5500	171.9	7.76	0.54	0.65	0.75	162.8	8.58	0.54	0.65	0.76	153.3	9.49	0.53	0.65	0.77	142.9	10.49	0.53	0.66	0.78
	6500	179.8	7.79	0.56	0.67	0.79	170.4	8.62	0.55	0.68	0.8	160.2	9.52	0.55	0.68	0.81	149.4	10.54	0.55	0.69	0.83
71°F	4500	172.7	7.76	0.42	0.51	0.6	164	8.58	0.4	0.5	0.6	154.3	9.48	0.39	0.5	0.59	144.2	10.51	0.38	0.49	0.59
	5500	183.1	7.8	0.42	0.53	0.63	173.4	8.63	0.41	0.52	0.63	163.2	9.53	0.41	0.52	0.63	152.3	10.55	0.39	0.51	0.63
	6500	191	7.83	0.43	0.54	0.65	180.4	8.66	0.42	0.54	0.66	169.9	9.57	0.41	0.54	0.67	158.6	10.6	0.41	0.54	0.67

20 TON STANDARD EFFICIENCY KCB240S4M (2ND STAGE) - MSAV® (Multi-Stage Air Volume) SUPPLY AIR BLOWER

Entering Wet Bulb Temperature	Total Air Volume	Outdoor Air Temperature Entering Outdoor Coil																			
		85°F					95°F					105°F					115°F				
		Total Cool Cap.	Comp. Motor Input	Sensible To Total Ratio (S/T)			Total Cool Cap.	Comp. Motor Input	Sensible To Total Ratio (S/T)			Total Cool Cap.	Comp. Motor Input	Sensible To Total Ratio (S/T)			Total Cool Cap.	Comp. Motor Input	Sensible To Total Ratio (S/T)		
				Dry Bulb					Dry Bulb					Dry Bulb					Dry Bulb		
cfm	kBtuh	kW	75°F	80°F	85°F	kBtuh	kW	75°F	80°F	85°F	kBtuh	kW	75°F	80°F	85°F	kBtuh	kW	75°F	80°F	85°F	
63°F	6400	229.2	14.28	0.72	0.87	1.00	213.1	15.83	0.73	0.89	1.00	196.7	17.56	0.74	0.91	1.00	179.0	19.54	0.76	0.95	1.00
	8000	241.7	14.36	0.78	0.95	1.00	225.1	15.91	0.80	0.97	1.00	207.9	17.66	0.82	0.99	1.00	190.3	19.63	0.84	1.00	1.00
	9600	251.8	14.43	0.84	1.00	1.00	235.3	15.99	0.85	1.00	1.00	219.3	17.75	0.88	1.00	1.00	201.7	19.72	0.91	1.00	1.00
67°F	6400	245.4	14.38	0.56	0.70	0.83	228.7	15.94	0.56	0.71	0.85	211.3	17.68	0.56	0.72	0.88	192.8	19.64	0.57	0.74	0.82
	8000	257.9	14.47	0.60	0.76	0.91	239.8	16.03	0.60	0.78	0.94	221.2	17.76	0.61	0.79	0.97	201.5	19.71	0.61	0.82	0.90
	9600	266.6	14.55	0.64	0.82	0.98	247.7	16.09	0.64	0.84	1.00	228.3	17.82	0.65	0.86	1.00	208.3	19.77	0.66	0.89	0.96
71°F	6400	262.0	14.51	0.41	0.55	0.68	243.9	16.05	0.41	0.55	0.69	226.3	17.8	0.4	0.55	0.70	207.1	19.77	0.39	0.56	0.66
	8000	274.6	14.61	0.43	0.59	0.74	255.5	16.16	0.43	0.59	0.76	236.0	17.89	0.42	0.6	0.77	215.9	19.84	0.41	0.61	0.72
	9600	283.2	14.67	0.45	0.63	0.80	263.5	16.23	0.44	0.64	0.82	242.7	17.94	0.44	0.65	0.84	222.4	19.89	0.43	0.66	0.78

RATINGS

STANDARD EFFICIENCY

NOTE - For Temperatures and Capacities not shown in tables, see bulletin - Cooling Unit Rating Table Correction Factor Data in Miscellaneous Engineering Data section.

25 TON STANDARD EFFICIENCY KCB300S4B (1ST STAGE) - CONSTANT AIR VOLUME

Entering Wet Bulb Temperature	Total Air Volume	Outdoor Air Temperature Entering Outdoor Coil																			
		65°F					75°F					85°F					95°F				
		Total Cool Cap.	Comp. Motor Input	Sensible To Total Ratio (S/T)			Total Cool Cap.	Comp. Motor Input	Sensible To Total Ratio (S/T)			Total Cool Cap.	Comp. Motor Input	Sensible To Total Ratio (S/T)			Total Cool Cap.	Comp. Motor Input	Sensible To Total Ratio (S/T)		
				Dry Bulb					Dry Bulb					Dry Bulb					Dry Bulb		
cfm	kBtuh	kW	75°F	80°F	85°F	kBtuh	kW	75°F	80°F	85°F	kBtuh	kW	75°F	80°F	85°F	kBtuh	kW	75°F	80°F	85°F	
63°F	8000	147.3	6.36	0.70	0.82	0.95	140.6	7.18	0.71	0.84	0.97	134.8	8.10	0.72	0.86	0.99	129.1	9.16	0.73	0.88	1.00
	9500	152.7	6.41	0.73	0.87	0.99	145.9	7.24	0.74	0.90	1.00	140.0	8.16	0.75	0.92	1.00	133.8	9.22	0.77	0.94	1.00
	11000	157.6	6.47	0.75	0.92	1.00	150.5	7.29	0.78	0.95	1.00	144.1	8.22	0.80	0.97	1.00	137.6	9.27	0.82	0.98	1.00
67°F	8000	156.1	6.45	0.55	0.67	0.79	149.2	7.27	0.56	0.68	0.81	142.8	8.20	0.57	0.70	0.83	136.3	9.25	0.57	0.70	0.84
	9500	161.6	6.51	0.57	0.70	0.84	154.0	7.33	0.58	0.71	0.86	147.3	8.26	0.59	0.73	0.88	140.8	9.31	0.60	0.75	0.91
	11000	165.6	6.55	0.59	0.73	0.89	158.2	7.38	0.60	0.76	0.92	151.1	8.31	0.61	0.77	0.94	144.2	9.37	0.63	0.79	0.96
71°F	8000	165.2	6.55	0.42	0.54	0.65	157.7	7.38	0.42	0.54	0.66	151.1	8.31	0.42	0.55	0.67	144.2	9.37	0.43	0.56	0.69
	9500	170.7	6.61	0.43	0.56	0.68	162.8	7.44	0.43	0.57	0.70	155.4	8.37	0.44	0.57	0.71	148.2	9.42	0.44	0.58	0.72
	11,000	174.8	6.66	0.44	0.58	0.71	166.6	7.49	0.45	0.59	0.73	159.1	8.42	0.44	0.60	0.75	151.8	9.47	0.45	0.61	0.77

25 TON STANDARD EFFICIENCY KCB300S4B (2ND STAGE) - CONSTANT AIR VOLUME

Entering Wet Bulb Temperature	Total Air Volume	Outdoor Air Temperature Entering Outdoor Coil																			
		85°F					95°F					105°F					115°F				
		Total Cool Cap.	Comp. Motor Input	Sensible To Total Ratio (S/T)			Total Cool Cap.	Comp. Motor Input	Sensible To Total Ratio (S/T)			Total Cool Cap.	Comp. Motor Input	Sensible To Total Ratio (S/T)			Total Cool Cap.	Comp. Motor Input	Sensible To Total Ratio (S/T)		
				Dry Bulb					Dry Bulb					Dry Bulb					Dry Bulb		
cfm	kBtuh	kW	75°F	80°F	85°F	kBtuh	kW	75°F	80°F	85°F	kBtuh	kW	75°F	80°F	85°F	kBtuh	kW	75°F	80°F	85°F	
63°F	8000	277.2	17.80	0.72	0.87	1.00	264.6	19.95	0.74	0.89	1.00	251.7	22.43	0.75	0.92	1.00	238.5	25.35	0.78	0.95	1.00
	9500	287.2	17.97	0.76	0.93	1.00	273.8	20.12	0.78	0.96	1.00	260.1	22.59	0.80	0.98	1.00	246.0	25.49	0.83	1.00	1.00
	11000	295.0	18.11	0.80	0.98	1.00	280.6	20.25	0.83	1.00	1.00	267.4	22.73	0.85	1.00	1.00	254.5	25.68	0.88	1.00	1.00
67°F	8000	293.2	18.08	0.57	0.70	0.83	279.6	20.23	0.58	0.71	0.86	265.8	22.71	0.59	0.73	0.88	251.7	25.63	0.60	0.75	0.91
	9500	302.9	18.25	0.59	0.74	0.89	288.4	20.39	0.60	0.76	0.92	273.9	22.86	0.62	0.78	0.95	258.8	25.78	0.63	0.80	0.98
	11000	310.1	18.38	0.62	0.78	0.95	295.3	20.52	0.63	0.80	0.98	279.9	22.99	0.64	0.83	1.00	264.5	25.89	0.65	0.85	1.00
71°F	8000	310.0	18.38	0.43	0.56	0.68	295.5	20.53	0.43	0.57	0.69	280.6	23.00	0.43	0.58	0.71	265.8	25.92	0.44	0.59	0.73
	9500	319.0	18.54	0.44	0.58	0.72	304.0	20.68	0.44	0.59	0.74	288.9	23.17	0.45	0.61	0.75	273.0	26.07	0.45	0.62	0.78
	11,000	326.9	18.68	0.44	0.61	0.76	311.2	20.82	0.45	0.62	0.78	294.9	23.29	0.46	0.63	0.80	278.5	26.19	0.47	0.65	0.83

25 TON STANDARD EFFICIENCY KCB300S4M (1ST STAGE) - MSAV® (Multi-Stage Air Volume) SUPPLY AIR BLOWER

Entering Wet Bulb Temperature	Total Air Volume	Outdoor Air Temperature Entering Outdoor Coil																			
		65°F					75°F					85°F					95°F				
		Total Cool Cap.	Comp. Motor Input	Sensible To Total Ratio (S/T)			Total Cool Cap.	Comp. Motor Input	Sensible To Total Ratio (S/T)			Total Cool Cap.	Comp. Motor Input	Sensible To Total Ratio (S/T)			Total Cool Cap.	Comp. Motor Input	Sensible To Total Ratio (S/T)		
				Dry Bulb					Dry Bulb					Dry Bulb					Dry Bulb		
cfm	kBtuh	kW	75°F	80°F	85°F	kBtuh	kW	75°F	80°F	85°F	kBtuh	kW	75°F	80°F	85°F	kBtuh	kW	75°F	80°F	85°F	
63°F	5750	135.3	6.25	0.65	0.75	0.86	130.0	7.06	0.66	0.77	0.88	124.8	7.98	0.66	0.78	0.89	119.7	9.04	0.67	0.79	0.91
	6750	141.3	6.30	0.67	0.79	0.90	135.5	7.12	0.68	0.80	0.92	129.8	8.04	0.69	0.82	0.94	124.3	9.10	0.70	0.83	0.96
	7750	146.0	6.35	0.69	0.82	0.94	139.8	7.17	0.70	0.84	0.96	133.9	8.09	0.72	0.86	0.98	128.1	9.14	0.73	0.87	0.99
67°F	5750	143.5	6.32	0.53	0.62	0.72	138.1	7.15	0.53	0.63	0.73	132.4	8.07	0.54	0.64	0.74	126.9	9.13	0.54	0.65	0.76
	6750	149.9	6.39	0.54	0.64	0.75	143.6	7.21	0.54	0.65	0.77	137.7	8.14	0.55	0.67	0.78	131.9	9.19	0.56	0.67	0.80
	7750	155.1	6.44	0.55	0.67	0.79	148.1	7.26	0.56	0.68	0.81	141.9	8.19	0.57	0.69	0.82	135.7	9.25	0.57	0.71	0.84
71°F	5750	151.7	6.41	0.42	0.51	0.60	145.6	7.24	0.42	0.51	0.61	140.1	8.17	0.42	0.52	0.61	134.2	9.23	0.42	0.52	0.62
	6750	158.3	6.48	0.42	0.52	0.62	151.7	7.31	0.42	0.53	0.63	145.6	8.24	0.42	0.53	0.64	139.7	9.30	0.42	0.54	0.65
	7750	164.2	6.54	0.42	0.54	0.64	156.7	7.37	0.41	0.54	0.65	150.2	8.30	0.42	0.55	0.67	143.3	9.35	0.43	0.56	0.68

25 TON STANDARD EFFICIENCY KCB300S4M (2ND STAGE) - MSAV® (Multi-Stage Air Volume) SUPPLY AIR BLOWER

Entering Wet Bulb Temperature	Total Air Volume	Outdoor Air Temperature Entering Outdoor Coil																			
		85°F					95°F					105°F					115°F				
		Total Cool Cap.	Comp. Motor Input	Sensible To Total Ratio (S/T)			Total Cool Cap.	Comp. Motor Input	Sensible To Total Ratio (S/T)			Total Cool Cap.	Comp. Motor Input	Sensible To Total Ratio (S/T)			Total Cool Cap.	Comp. Motor Input	Sensible To Total Ratio (S/T)		
				Dry Bulb					Dry Bulb					Dry Bulb					Dry Bulb		
cfm	kBtuh	kW	75°F	80°F	85°F	kBtuh	kW	75°F	80°F	85°F	kBtuh	kW	75°F	80°F	85°F	kBtuh	kW	75°F	80°F	85°F	
63°F	8000	277.2	17.80	0.72	0.87	1.00	264.6	19.95	0.74	0.89	1.00	251.7	22.43	0.75	0.92	1.00	238.5	25.35	0.78	0.95	1.00
	9500	287.2	17.97	0.76	0.93	1.00	273.8	20.12	0.78	0.96	1.00	260.1	22.59	0.80	0.98	1.00	246.0	25.49	0.83	1.00	1.00
	11000	295.0	18.11	0.80	0.98	1.00	280.6	20.25	0.83	1.00	1.00	267.4	22.73	0.85	1.00	1.00	254.5	25.68	0.88	1.00	1.00
67°F	8000	293.2	18.08	0.57	0.70	0.83	279.6	20.23	0.58	0.71	0.86	265.8	22.71	0.59	0.73	0.88	251.7	25.63	0.60	0.75	0.91
	9500	302.9	18.25	0.59	0.74	0.89	288.4	20.39	0.60	0.76	0.92	273.9	22.86	0.62	0.78	0.95	258.8	25.78	0.63	0.80	0.98
	11000	310.1	18.38	0.62	0.78	0.95	295.3	20.52	0.63	0.80	0.98	279.9	22.99	0.64	0.83	1.00	264.5	25.89	0.65	0.85	1.00
71°F	8000	310.0	18.38	0.43	0.56	0.68	295.5	20.53	0.43	0.57	0.69	280.6	23.00	0.43	0.58	0.71	265.8	25.92	0.44	0.59	0.73
	9500	319.0	18.54	0.44	0.58	0.72	304.0	20.68	0.44	0.59	0.74	288.9	23.17	0.45	0.61	0.75	273.0	26.07	0.45	0.62	0.78
	11,000	326.9	18.68	0.44	0.61	0.76	311.2	20.82	0.45	0.62	0.78	294.9	23.29	0.46	0.63	0.80	278.5	26.19	0.47	0.65	0.83

RATINGS

HIGH EFFICIENCY

NOTE - For Temperatures and Capacities not shown in tables, see bulletin - Cooling Unit Rating Table Correction Factor Data in Miscellaneous Engineering Data section.

13 TON HIGH EFFICIENCY KCA156H4B (1ST STAGE) - CONSTANT AIR VOLUME

Entering Wet Bulb Temperature	Total Air Volume	Outdoor Air Temperature Entering Outdoor Coil																			
		65°F					75°F					85°F					95°F				
		Total Cool Cap.	Comp. Motor Input	Sensible To Total Ratio (S/T)			Total Cool Cap.	Comp. Motor Input	Sensible To Total Ratio (S/T)			Total Cool Cap.	Comp. Motor Input	Sensible To Total Ratio (S/T)			Total Cool Cap.	Comp. Motor Input	Sensible To Total Ratio (S/T)		
				Dry Bulb					Dry Bulb					Dry Bulb					Dry Bulb		
cfm	kBtuh	kW	75°F	80°F	85°F	kBtuh	kW	75°F	80°F	85°F	kBtuh	kW	75°F	80°F	85°F	kBtuh	kW	75°F	80°F	85°F	
63°F	4160	110.6	4.68	0.67	0.80	0.93	103.7	5.30	0.68	0.81	0.95	96.4	5.97	0.68	0.82	0.97	88.8	6.74	0.68	0.84	0.99
	5200	117.9	4.73	0.72	0.87	0.99	110.4	5.34	0.72	0.88	1.00	102.7	6.01	0.73	0.90	1.00	94.7	6.78	0.74	0.93	1.00
	6240	123.1	4.77	0.76	0.93	1.00	115.4	5.38	0.77	0.95	1.00	107.5	6.05	0.79	0.97	1.00	99.3	6.81	0.80	0.99	1.00
67°F	4160	118.4	4.73	0.54	0.65	0.77	111.2	5.34	0.53	0.65	0.78	103.8	6.02	0.52	0.66	0.79	96.0	6.79	0.52	0.66	0.80
	5200	126.0	4.79	0.57	0.70	0.83	118.4	5.39	0.56	0.70	0.85	110.5	6.07	0.56	0.71	0.86	102.2	6.83	0.56	0.72	0.89
	6240	131.7	4.83	0.59	0.74	0.90	123.6	5.43	0.59	0.75	0.91	115.4	6.11	0.59	0.76	0.94	106.7	6.87	0.59	0.78	0.96
71°F	4160	126.1	4.78	0.42	0.53	0.63	118.8	5.39	0.40	0.52	0.63	111.2	6.07	0.39	0.52	0.63	103.1	6.84	0.37	0.51	0.64
	5200	134.1	4.84	0.43	0.55	0.67	126.1	5.45	0.41	0.55	0.68	118.0	6.13	0.4	0.55	0.69	109.6	6.89	0.39	0.55	0.70
	6240	140.0	4.88	0.44	0.58	0.72	131.7	5.49	0.42	0.58	0.73	123.3	6.17	0.42	0.59	0.74	114.3	6.93	0.40	0.59	0.76

13 TON HIGH EFFICIENCY KCA156H4B (2ND STAGE) - CONSTANT AIR VOLUME

Entering Wet Bulb Temperature	Total Air Volume	Outdoor Air Temperature Entering Outdoor Coil																			
		85°F					95°F					105°F					115°F				
		Total Cool Cap.	Comp. Motor Input	Sensible To Total Ratio (S/T)			Total Cool Cap.	Comp. Motor Input	Sensible To Total Ratio (S/T)			Total Cool Cap.	Comp. Motor Input	Sensible To Total Ratio (S/T)			Total Cool Cap.	Comp. Motor Input	Sensible To Total Ratio (S/T)		
				Dry Bulb					Dry Bulb					Dry Bulb					Dry Bulb		
cfm	kBtuh	kW	75°F	80°F	85°F	kBtuh	kW	75°F	80°F	85°F	kBtuh	kW	75°F	80°F	85°F	kBtuh	kW	75°F	80°F	85°F	
63°F	4160	148.1	9.05	0.70	0.85	0.99	136.5	10.20	0.71	0.87	1.00	124.5	11.51	0.72	0.9	1.00	112.1	13.01	0.73	0.93	1.00
	5200	157.1	9.11	0.76	0.94	1.00	145.1	10.26	0.77	0.96	1.00	132.6	11.57	0.79	0.99	1.00	120.5	13.08	0.81	1.00	1.00
	6240	164.5	9.17	0.82	0.99	1.00	152.7	10.32	0.83	1.00	1.00	141.1	11.64	0.86	1.00	1.00	129.1	13.15	0.89	1.00	1.00
67°F	4160	159.3	9.13	0.54	0.68	0.82	147.4	10.28	0.54	0.69	0.84	135.3	11.59	0.53	0.70	0.86	122.4	13.09	0.53	0.71	0.89
	5200	169.0	9.20	0.58	0.74	0.90	156.5	10.35	0.58	0.75	0.92	143.4	11.66	0.58	0.77	0.95	129.8	13.16	0.58	0.79	0.98
	6240	175.9	9.25	0.61	0.80	0.97	162.7	10.40	0.62	0.81	0.99	149.1	11.71	0.62	0.83	1.00	135.2	13.20	0.63	0.86	1.00
71°F	4160	170.4	9.21	0.40	0.53	0.66	158.1	10.36	0.38	0.53	0.66	145.8	11.68	0.37	0.53	0.67	132.6	13.18	0.35	0.52	0.69
	5200	180.5	9.29	0.41	0.57	0.72	167.6	10.44	0.41	0.57	0.73	154.2	11.75	0.39	0.57	0.74	140.5	13.25	0.37	0.58	0.76
	6240	187.9	9.35	0.43	0.61	0.77	174.4	10.50	0.42	0.61	0.79	160.4	11.81	0.41	0.61	0.81	146.2	13.31	0.40	0.62	0.84

13 TON HIGH EFFICIENCY KCA156H4M (1ST STAGE) - MSAV® (Multi-Stage Air Volume) SUPPLY AIR BLOWER

Entering Wet Bulb Temperature	Total Air Volume	Outdoor Air Temperature Entering Outdoor Coil																			
		65°F					75°F					85°F					95°F				
		Total Cool Cap.	Comp. Motor Input	Sensible To Total Ratio (S/T)			Total Cool Cap.	Comp. Motor Input	Sensible To Total Ratio (S/T)			Total Cool Cap.	Comp. Motor Input	Sensible To Total Ratio (S/T)			Total Cool Cap.	Comp. Motor Input	Sensible To Total Ratio (S/T)		
				Dry Bulb					Dry Bulb					Dry Bulb					Dry Bulb		
cfm	kBtuh	kW	75°F	80°F	85°F	kBtuh	kW	75°F	80°F	85°F	kBtuh	kW	75°F	80°F	85°F	kBtuh	kW	75°F	80°F	85°F	
63°F	3000	101.3	4.50	0.67	0.77	0.86	95.0	5.11	0.67	0.77	0.87	88.4	5.78	0.66	0.78	0.88	81.4	6.53	0.66	0.78	0.90
	3500	107.4	4.53	0.69	0.8	0.9	100.7	5.14	0.69	0.80	0.91	93.7	5.81	0.69	0.81	0.93	86.4	6.56	0.69	0.82	0.94
	4000	112.3	4.56	0.71	0.83	0.94	105.3	5.16	0.71	0.83	0.95	98.0	5.83	0.71	0.85	0.97	90.4	6.58	0.72	0.86	0.99
67°F	3000	108.8	4.54	0.54	0.65	0.74	102.3	5.15	0.53	0.64	0.74	95.5	5.81	0.52	0.64	0.74	88.3	6.57	0.51	0.64	0.75
	3500	115.1	4.57	0.56	0.67	0.77	108.2	5.18	0.55	0.67	0.77	101.0	5.84	0.54	0.67	0.78	93.5	6.59	0.53	0.67	0.79
	4000	120.3	4.60	0.57	0.69	0.80	113.1	5.21	0.57	0.69	0.80	105.5	5.87	0.56	0.69	0.81	97.7	6.62	0.55	0.70	0.83
71°F	3000	116.1	4.57	0.43	0.53	0.62	109.4	5.18	0.41	0.52	0.62	102.4	5.85	0.4	0.51	0.61	95.1	6.60	0.38	0.50	0.61
	3500	122.7	4.61	0.44	0.54	0.65	115.6	5.22	0.42	0.54	0.65	108.2	5.88	0.41	0.53	0.64	100.5	6.63	0.39	0.52	0.65
	4000	128.1	4.64	0.44	0.56	0.67	120.7	5.25	0.43	0.55	0.67	113.0	5.91	0.42	0.55	0.67	104.9	6.66	0.40	0.54	0.68

13 TON HIGH EFFICIENCY KCA156H4M (2ND STAGE) - MSAV® (Multi-Stage Air Volume) SUPPLY AIR BLOWER

Entering Wet Bulb Temperature	Total Air Volume	Outdoor Air Temperature Entering Outdoor Coil																			
		85°F					95°F					105°F					115°F				
		Total Cool Cap.	Comp. Motor Input	Sensible To Total Ratio (S/T)			Total Cool Cap.	Comp. Motor Input	Sensible To Total Ratio (S/T)			Total Cool Cap.	Comp. Motor Input	Sensible To Total Ratio (S/T)			Total Cool Cap.	Comp. Motor Input	Sensible To Total Ratio (S/T)		
				Dry Bulb					Dry Bulb					Dry Bulb					Dry Bulb		
cfm	kBtuh	kW	75°F	80°F	85°F	kBtuh	kW	75°F	80°F	85°F	kBtuh	kW	75°F	80°F	85°F	kBtuh	kW	75°F	80°F	85°F	
63°F	4160	148.1	9.05	0.70	0.85	0.99	136.5	10.20	0.71	0.87	1.00	124.5	11.51	0.72	0.9	1.00	112.1	13.01	0.73	0.93	1.00
	5200	157.1	9.11	0.76	0.94	1.00	145.1	10.26	0.77	0.96	1.00	132.6	11.57	0.79	0.99	1.00	120.5	13.08	0.81	1.00	1.00
	6240	164.5	9.17	0.82	0.99	1.00	152.7	10.32	0.83	1.00	1.00	141.1	11.64	0.86	1.00	1.00	129.1	13.15	0.89	1.00	1.00
67°F	4160	159.3	9.13	0.54	0.68	0.82	147.4	10.28	0.54	0.69	0.84	135.3	11.59	0.53	0.70	0.86	122.4	13.09	0.53	0.71	0.89
	5200	169.0	9.20	0.58	0.74	0.90	156.5	10.35	0.58	0.75	0.92	143.4	11.66	0.58	0.77	0.95	129.8	13.16	0.58	0.79	0.98
	6240	175.9	9.25	0.61	0.80	0.97	162.7	10.40	0.62	0.81	0.99	149.1	11.71	0.62	0.83	1.00	135.2	13.20	0.63	0.86	1.00
71°F	4160	170.4	9.21	0.40	0.53	0.66	158.1	10.36	0.38	0.53	0.66	145.8	11.68	0.37	0.53	0.67	132.6	13.18	0.35	0.52	0.69
	5200	180.5	9.29	0.41	0.57	0.72	167.6	10.44	0.41	0.57	0.73	154.2	11.75	0.39	0.57	0.74	140.5	13.25	0.37	0.58	0.76
	6240	187.9	9.35	0.43	0.61	0.77	174.4	10.50	0.42	0.61	0.79	160.4	11.81	0.41	0.61	0.81	146.2	13.31	0.40	0.62	0.84

RATINGS

HIGH EFFICIENCY

NOTE - For Temperatures and Capacities not shown in tables, see bulletin - Cooling Unit Rating Table Correction Factor Data in Miscellaneous Engineering Data section.

15 TON HIGH EFFICIENCY KCA180H4B (1ST STAGE) - CONSTANT AIR VOLUME

Entering Wet Bulb Temperature	Total Air Volume	Outdoor Air Temperature Entering Outdoor Coil																			
		65°F					75°F					85°F					95°F				
		Total Cool Cap.	Comp. Motor Input	Sensible To Total Ratio (S/T)			Total Cool Cap.	Comp. Motor Input	Sensible To Total Ratio (S/T)			Total Cool Cap.	Comp. Motor Input	Sensible To Total Ratio (S/T)			Total Cool Cap.	Comp. Motor Input	Sensible To Total Ratio (S/T)		
				Dry Bulb					Dry Bulb					Dry Bulb					Dry Bulb		
cfm	kBtuh	kW	75°F	80°F	85°F	kBtuh	kW	75°F	80°F	85°F	kBtuh	kW	75°F	80°F	85°F	kBtuh	kW	75°F	80°F	85°F	
63°F	4800	127.8	5.04	0.70	0.82	0.93	120.4	5.79	0.7	0.82	0.94	112.8	6.62	0.70	0.83	0.96	104.8	7.53	0.70	0.85	0.98
	6000	136.3	5.05	0.74	0.87	0.99	128.3	5.81	0.75	0.88	1.00	120.1	6.64	0.75	0.90	1.00	111.6	7.56	0.76	0.92	1.00
	7200	142.4	5.05	0.78	0.92	1.00	134.1	5.82	0.79	0.94	1.00	125.4	6.66	0.80	0.96	1.00	116.7	7.58	0.81	0.98	1.00
67°F	4800	136.5	5.05	0.56	0.68	0.79	129.0	5.81	0.55	0.68	0.79	121.1	6.65	0.55	0.68	0.80	112.8	7.56	0.54	0.68	0.81
	6000	145.4	5.06	0.59	0.72	0.84	137.2	5.83	0.58	0.72	0.85	128.8	6.67	0.58	0.73	0.86	120.1	7.60	0.58	0.74	0.88
	7200	151.9	5.06	0.61	0.76	0.89	143.3	5.84	0.61	0.77	0.91	134.5	6.69	0.61	0.78	0.93	125.3	7.62	0.61	0.79	0.95
71°F	4800	145.1	5.06	0.44	0.55	0.65	137.2	5.83	0.42	0.54	0.65	129.2	6.67	0.41	0.54	0.66	120.6	7.60	0.40	0.53	0.66
	6000	154.3	5.07	0.45	0.57	0.70	145.9	5.85	0.43	0.57	0.70	137.2	6.70	0.42	0.57	0.71	128.1	7.63	0.41	0.57	0.71
	7200	161.0	5.08	0.46	0.6	0.74	152.3	5.86	0.44	0.6	0.74	143.1	6.72	0.44	0.6	0.76	133.6	7.66	0.43	0.61	0.77

15 TON HIGH EFFICIENCY KCA180H4B (2ND STAGE) - CONSTANT AIR VOLUME

Entering Wet Bulb Temperature	Total Air Volume	Outdoor Air Temperature Entering Outdoor Coil																			
		85°F					95°F					105°F					115°F				
		Total Cool Cap.	Comp. Motor Input	Sensible To Total Ratio (S/T)			Total Cool Cap.	Comp. Motor Input	Sensible To Total Ratio (S/T)			Total Cool Cap.	Comp. Motor Input	Sensible To Total Ratio (S/T)			Total Cool Cap.	Comp. Motor Input	Sensible To Total Ratio (S/T)		
				Dry Bulb					Dry Bulb					Dry Bulb					Dry Bulb		
cfm	kBtuh	kW	75°F	80°F	85°F	kBtuh	kW	75°F	80°F	85°F	kBtuh	kW	75°F	80°F	85°F	kBtuh	kW	75°F	80°F	85°F	
63°F	4800	172.5	9.96	0.71	0.85	0.99	160.1	11.32	0.71	0.87	1.00	146.8	12.83	0.72	0.90	1.00	132.7	14.51	0.74	0.93	1.00
	6000	182.6	9.99	0.77	0.93	1.00	169.5	11.37	0.78	0.95	1.00	155.7	12.89	0.79	0.98	1.00	141.3	14.57	0.81	1.00	1.00
	7200	190.3	10.02	0.82	0.99	1.00	177.3	11.41	0.83	1.00	1.00	164.3	12.94	0.86	1.00	1.00	150.5	14.64	0.89	1.00	1.00
67°F	4800	185.0	10.00	0.55	0.69	0.82	172.1	11.38	0.55	0.69	0.84	158.6	12.90	0.54	0.70	0.86	144.0	14.59	0.54	0.72	0.89
	6000	195.8	10.04	0.58	0.74	0.90	182.1	11.43	0.58	0.76	0.92	167.5	12.96	0.59	0.77	0.95	152.2	14.65	0.59	0.79	0.98
	7200	203.7	10.07	0.62	0.8	0.97	189.3	11.46	0.62	0.81	0.99	173.9	13.00	0.63	0.84	1.00	157.8	14.69	0.63	0.86	1.00
71°F	4800	197.2	10.04	0.41	0.54	0.67	183.9	11.43	0.39	0.54	0.67	169.9	12.97	0.38	0.53	0.68	155.0	14.67	0.36	0.53	0.69
	6000	208.4	10.09	0.42	0.58	0.72	194.2	11.48	0.41	0.58	0.73	179.4	13.03	0.4	0.58	0.75	163.3	14.73	0.38	0.59	0.77
	7200	216.6	10.12	0.43	0.61	0.78	201.8	11.52	0.42	0.62	0.79	186.2	13.07	0.42	0.62	0.81	169.7	14.78	0.41	0.63	0.84

15 TON HIGH EFFICIENCY KCA180H4M (1ST STAGE) - MSAV® (Multi-Stage Air Volume) SUPPLY AIR BLOWER

Entering Wet Bulb Temperature	Total Air Volume	Outdoor Air Temperature Entering Outdoor Coil																			
		65°F					75°F					85°F					95°F				
		Total Cool Cap.	Comp. Motor Input	Sensible To Total Ratio (S/T)			Total Cool Cap.	Comp. Motor Input	Sensible To Total Ratio (S/T)			Total Cool Cap.	Comp. Motor Input	Sensible To Total Ratio (S/T)			Total Cool Cap.	Comp. Motor Input	Sensible To Total Ratio (S/T)		
				Dry Bulb					Dry Bulb					Dry Bulb					Dry Bulb		
cfm	kBtuh	kW	75°F	80°F	85°F	kBtuh	kW	75°F	80°F	85°F	kBtuh	kW	75°F	80°F	85°F	kBtuh	kW	75°F	80°F	85°F	
63°F	3500	117.6	5.01	0.66	0.76	0.85	110.9	5.76	0.66	0.76	0.86	103.9	6.57	0.65	0.76	0.87	96.6	7.47	0.65	0.77	0.88
	4000	123.6	5.02	0.68	0.78	0.88	116.6	5.77	0.67	0.79	0.89	109.3	6.59	0.67	0.79	0.91	101.6	7.49	0.67	0.80	0.92
	4500	128.7	5.02	0.69	0.81	0.91	121.3	5.78	0.69	0.81	0.93	113.8	6.60	0.69	0.82	0.94	105.7	7.51	0.70	0.83	0.96
67°F	3500	126.1	5.02	0.54	0.63	0.73	119.1	5.77	0.53	0.63	0.73	112.0	6.59	0.52	0.63	0.73	104.3	7.50	0.51	0.63	0.74
	4000	132.3	5.03	0.55	0.65	0.75	125.1	5.78	0.54	0.65	0.76	117.5	6.61	0.53	0.65	0.76	109.6	7.52	0.52	0.65	0.77
	4500	137.6	5.03	0.56	0.67	0.78	130.0	5.80	0.55	0.67	0.78	122.1	6.63	0.55	0.67	0.79	113.9	7.54	0.54	0.68	0.80
71°F	3500	134.4	5.03	0.42	0.52	0.61	127.2	5.79	0.41	0.51	0.61	119.7	6.62	0.40	0.50	0.61	112.0	7.53	0.38	0.49	0.60
	4000	140.9	5.03	0.43	0.53	0.63	133.3	5.80	0.42	0.53	0.63	125.5	6.64	0.40	0.52	0.63	117.3	7.55	0.39	0.51	0.63
	4500	146.3	5.04	0.43	0.54	0.65	138.5	5.81	0.42	0.54	0.65	130.3	6.65	0.41	0.53	0.65	121.8	7.57	0.40	0.53	0.65

15 TON HIGH EFFICIENCY KCA180H4M (2ND STAGE) - MSAV® (Multi-Stage Air Volume) SUPPLY AIR BLOWER

Entering Wet Bulb Temperature	Total Air Volume	Outdoor Air Temperature Entering Outdoor Coil																			
		85°F					95°F					105°F					115°F				
		Total Cool Cap.	Comp. Motor Input	Sensible To Total Ratio (S/T)			Total Cool Cap.	Comp. Motor Input	Sensible To Total Ratio (S/T)			Total Cool Cap.	Comp. Motor Input	Sensible To Total Ratio (S/T)			Total Cool Cap.	Comp. Motor Input	Sensible To Total Ratio (S/T)		
				Dry Bulb					Dry Bulb					Dry Bulb					Dry Bulb		
cfm	kBtuh	kW	75°F	80°F	85°F	kBtuh	kW	75°F	80°F	85°F	kBtuh	kW	75°F	80°F	85°F	kBtuh	kW	75°F	80°F	85°F	
63°F	4800	172.5	9.96	0.71	0.85	0.99	160.1	11.32	0.71	0.87	1.00	146.8	12.83	0.72	0.90	1.00	132.7	14.51	0.74	0.93	1.00
	6000	182.6	9.99	0.77	0.93	1.00	169.5	11.37	0.78	0.95	1.00	155.7	12.89	0.79	0.98	1.00	141.3	14.57	0.81	1.00	1.00
	7200	190.3	10.02	0.82	0.99	1.00	177.3	11.41	0.83	1.00	1.00	164.3	12.94	0.86	1.00	1.00	150.5	14.64	0.89	1.00	1.00
67°F	4800	185.0	10.00	0.55	0.69	0.82	172.1	11.38	0.55	0.69	0.84	158.6	12.90	0.54	0.70	0.86	144.0	14.59	0.54	0.72	0.89
	6000	195.8	10.04	0.58	0.74	0.90	182.1	11.43	0.58	0.76	0.92	167.5	12.96	0.59	0.77	0.95	152.2	14.65	0.59	0.79	0.98
	7200	203.7	10.07	0.62	0.8	0.97	189.3	11.46	0.62	0.81	0.99	173.9	13.00	0.63	0.84	1.00	157.8	14.69	0.63	0.86	1.00
71°F	4800	197.2	10.04	0.41	0.54	0.67	183.9	11.43	0.39	0.54	0.67	169.9	12.97	0.38	0.53	0.68	155.0	14.67	0.36	0.53	0.69
	6000	208.4	10.09	0.42	0.58	0.72	194.2	11.48	0.41	0.58	0.73	179.4	13.03	0.4	0.58	0.75	163.3	14.73	0.38	0.59	0.77
	7200	216.6	10.12	0.43	0.61	0.78	201.8	11.52	0.42	0.62	0.79	186.2	13.07	0.42	0.62	0.81	169.7	14.78	0.41	0.63	0.84

RATINGS

HIGH EFFICIENCY

NOTE - For Temperatures and Capacities not shown in tables, see bulletin - Cooling Unit Rating Table Correction Factor Data in Miscellaneous Engineering Data section.

17.5 TON HIGH EFFICIENCY KCA210H4B (1ST STAGE) - CONSTANT AIR VOLUME

Entering Wet Bulb Temperature	Total Air Volume	Outdoor Air Temperature Entering Outdoor Coil																			
		65°F					75°F					85°F					95°F				
		Total Cool Cap.	Comp. Motor Input	Sensible To Total Ratio (S/T)			Total Cool Cap.	Comp. Motor Input	Sensible To Total Ratio (S/T)			Total Cool Cap.	Comp. Motor Input	Sensible To Total Ratio (S/T)			Total Cool Cap.	Comp. Motor Input	Sensible To Total Ratio (S/T)		
				Dry Bulb					Dry Bulb					Dry Bulb					Dry Bulb		
cfm	kBtuh	kW	75°F	80°F	85°F	kBtuh	kW	75°F	80°F	85°F	kBtuh	kW	75°F	80°F	85°F	kBtuh	kW	75°F	80°F	85°F	
63°F	5600	142.9	5.49	0.71	0.85	0.97	134.4	6.23	0.72	0.86	0.99	125.5	7.05	0.72	0.88	1.00	116.4	7.97	0.74	0.9	1.00
	7000	151.1	5.54	0.76	0.92	1.00	142.3	6.29	0.77	0.94	1.00	133	7.11	0.79	0.96	1.00	123.5	8.03	0.80	0.98	1.00
	8400	157.9	5.58	0.82	0.98	1.00	148.7	6.34	0.83	1.00	1.00	139.3	7.16	0.84	1.00	1.00	130.5	8.08	0.87	1.00	1.00
67°F	5600	153.6	5.55	0.56	0.69	0.81	144.5	6.30	0.56	0.69	0.83	135.3	7.13	0.56	0.70	0.84	125.7	8.04	0.56	0.71	0.86
	7000	161.9	5.61	0.60	0.74	0.88	152.1	6.36	0.6	0.75	0.90	142.5	7.19	0.60	0.77	0.92	132.2	8.10	0.61	0.78	0.95
	8400	167.9	5.65	0.63	0.79	0.95	157.9	6.41	0.63	0.81	0.97	147.6	7.23	0.63	0.82	0.99	137.0	8.14	0.63	0.84	1.00
71°F	5600	164.4	5.63	0.43	0.55	0.67	154.9	6.38	0.42	0.55	0.67	145.2	7.21	0.41	0.54	0.68	135.3	8.13	0.4	0.55	0.69
	7000	172.9	5.69	0.45	0.59	0.72	162.9	6.45	0.44	0.59	0.73	152.6	7.27	0.43	0.59	0.74	142.1	8.19	0.42	0.60	0.76
	8400	179.1	5.74	0.45	0.62	0.77	168.6	6.49	0.46	0.63	0.79	157.8	7.32	0.45	0.63	0.8	146.5	8.24	0.44	0.64	0.82

17.5 TON HIGH EFFICIENCY KCA210H4B (2ND STAGE) - CONSTANT AIR VOLUME

Entering Wet Bulb Temperature	Total Air Volume	Outdoor Air Temperature Entering Outdoor Coil																			
		85°F					95°F					105°F					115°F				
		Total Cool Cap.	Comp. Motor Input	Sensible To Total Ratio (S/T)			Total Cool Cap.	Comp. Motor Input	Sensible To Total Ratio (S/T)			Total Cool Cap.	Comp. Motor Input	Sensible To Total Ratio (S/T)			Total Cool Cap.	Comp. Motor Input	Sensible To Total Ratio (S/T)		
				Dry Bulb					Dry Bulb					Dry Bulb					Dry Bulb		
cfm	kBtuh	kW	75°F	80°F	85°F	kBtuh	kW	75°F	80°F	85°F	kBtuh	kW	75°F	80°F	85°F	kBtuh	kW	75°F	80°F	85°F	
63°F	5600	197.5	11.26	0.71	0.86	0.99	183.2	12.71	0.73	0.89	1.00	168.8	14.37	0.74	0.91	1.00	153.6	16.25	0.75	0.94	1.00
	7000	209.3	11.34	0.78	0.95	1.00	194.5	12.8	0.79	0.97	1.00	179.6	14.45	0.81	0.99	1.00	164.6	16.33	0.83	1.00	1.00
	8400	219.3	11.42	0.83	0.99	1.00	205.2	12.89	0.85	1.00	1.00	190.5	14.55	0.88	1.00	1.00	175.2	16.42	0.91	1.00	1.00
67°F	5600	212.6	11.36	0.55	0.69	0.83	198.1	12.83	0.55	0.70	0.85	182.6	14.48	0.55	0.71	0.87	166.4	16.34	0.55	0.73	0.90
	7000	224.4	11.46	0.59	0.76	0.91	208.9	12.92	0.60	0.77	0.94	192.3	14.56	0.60	0.79	0.96	175.2	16.41	0.60	0.81	0.98
	8400	232.7	11.52	0.62	0.81	0.98	216.2	12.98	0.63	0.83	0.99	199.3	14.62	0.64	0.85	1.00	181.7	16.47	0.64	0.88	1.00
71°F	5600	228.4	11.49	0.41	0.54	0.67	212.9	12.95	0.40	0.54	0.68	197.0	14.60	0.39	0.55	0.69	180.1	16.46	0.38	0.55	0.71
	7000	240.3	11.59	0.42	0.59	0.73	223.9	13.05	0.42	0.59	0.75	206.9	14.69	0.41	0.59	0.76	189.0	16.54	0.40	0.60	0.78
	8400	248.5	11.66	0.44	0.62	0.79	231.5	13.12	0.44	0.63	0.81	214.0	14.75	0.43	0.64	0.83	195.1	16.60	0.42	0.64	0.86

17.5 TON HIGH EFFICIENCY KCA210H4M (1ST STAGE) - MSAV® (Multi-Stage Air Volume) SUPPLY AIR BLOWER

Entering Wet Bulb Temperature	Total Air Volume	Outdoor Air Temperature Entering Outdoor Coil																			
		65°F					75°F					85°F					95°F				
		Total Cool Cap.	Comp. Motor Input	Sensible To Total Ratio (S/T)			Total Cool Cap.	Comp. Motor Input	Sensible To Total Ratio (S/T)			Total Cool Cap.	Comp. Motor Input	Sensible To Total Ratio (S/T)			Total Cool Cap.	Comp. Motor Input	Sensible To Total Ratio (S/T)		
				Dry Bulb					Dry Bulb					Dry Bulb					Dry Bulb		
cfm	kBtuh	kW	75°F	80°F	85°F	kBtuh	kW	75°F	80°F	85°F	kBtuh	kW	75°F	80°F	85°F	kBtuh	kW	75°F	80°F	85°F	
63°F	4000	132.5	5.42	0.67	0.78	0.89	124.8	6.17	0.67	0.78	0.90	116.7	6.99	0.66	0.79	0.91	108.3	7.91	0.67	0.80	0.93
	4750	140.2	5.46	0.69	0.82	0.93	131.8	6.21	0.70	0.83	0.95	123.3	7.04	0.7	0.84	0.97	114.2	7.96	0.7	0.86	0.99
	5500	146.1	5.50	0.72	0.86	0.98	137.3	6.25	0.73	0.87	0.99	128.4	7.07	0.73	0.89	1.00	119.1	7.99	0.75	0.91	1.00
67°F	4000	143.1	5.48	0.54	0.64	0.75	134.9	6.23	0.53	0.64	0.75	126.4	7.05	0.52	0.64	0.76	117.6	7.98	0.52	0.64	0.77
	4750	150.9	5.52	0.55	0.67	0.78	142.3	6.28	0.55	0.67	0.79	133.3	7.10	0.54	0.68	0.81	123.7	8.03	0.54	0.68	0.82
	5500	157.2	5.56	0.57	0.70	0.82	147.9	6.32	0.57	0.70	0.84	138.6	7.15	0.57	0.71	0.85	128.5	8.06	0.57	0.72	0.87
71°F	4000	153.5	5.54	0.42	0.52	0.62	145.1	6.29	0.41	0.52	0.62	136.3	7.12	0.4	0.51	0.62	126.9	8.05	0.38	0.5	0.62
	4750	161.7	5.59	0.43	0.54	0.65	152.6	6.35	0.42	0.54	0.65	143.3	7.18	0.41	0.53	0.66	133.3	8.10	0.39	0.53	0.66
	5500	168.2	5.63	0.43	0.56	0.68	158.5	6.39	0.42	0.56	0.68	148.9	7.22	0.41	0.56	0.69	138.7	8.15	0.41	0.56	0.70

17.5 TON HIGH EFFICIENCY KCA210H4M (2ND STAGE) - MSAV® (Multi-Stage Air Volume) SUPPLY AIR BLOWER

Entering Wet Bulb Temperature	Total Air Volume	Outdoor Air Temperature Entering Outdoor Coil																			
		85°F					95°F					105°F					115°F				
		Total Cool Cap.	Comp. Motor Input	Sensible To Total Ratio (S/T)			Total Cool Cap.	Comp. Motor Input	Sensible To Total Ratio (S/T)			Total Cool Cap.	Comp. Motor Input	Sensible To Total Ratio (S/T)			Total Cool Cap.	Comp. Motor Input	Sensible To Total Ratio (S/T)		
				Dry Bulb					Dry Bulb					Dry Bulb					Dry Bulb		
cfm	kBtuh	kW	75°F	80°F	85°F	kBtuh	kW	75°F	80°F	85°F	kBtuh	kW	75°F	80°F	85°F	kBtuh	kW	75°F	80°F	85°F	
63°F	5600	197.5	11.26	0.71	0.86	0.99	183.2	12.71	0.73	0.89	1.00	168.8	14.37	0.74	0.91	1.00	153.6	16.25	0.75	0.94	1.00
	7000	209.3	11.34	0.78	0.95	1.00	194.5	12.8	0.79	0.97	1.00	179.6	14.45	0.81	0.99	1.00	164.6	16.33	0.83	1.00	1.00
	8400	219.3	11.42	0.83	0.99	1.00	205.2	12.89	0.85	1.00	1.00	190.5	14.55	0.88	1.00	1.00	175.2	16.42	0.91	1.00	1.00
67°F	5600	212.6	11.36	0.55	0.69	0.83	198.1	12.83	0.55	0.70	0.85	182.6	14.48	0.55	0.71	0.87	166.4	16.34	0.55	0.73	0.90
	7000	224.4	11.46	0.59	0.76	0.91	208.9	12.92	0.60	0.77	0.94	192.3	14.56	0.60	0.79	0.96	175.2	16.41	0.60	0.81	0.98
	8400	232.7	11.52	0.62	0.81	0.98	216.2	12.98	0.63	0.83	0.99	199.3	14.62	0.64	0.85	1.00	181.7	16.47	0.64	0.88	1.00
71°F	5600	228.4	11.49	0.41	0.54	0.67	212.9	12.95	0.40	0.54	0.68	197.0	14.60	0.39	0.55	0.69	180.1	16.46	0.38	0.55	0.71
	7000	240.3	11.59	0.42	0.59	0.73	223.9	13.05	0.42	0.59	0.75	206.9	14.69	0.41	0.59	0.76	189.0	16.54	0.40	0.60	0.78
	8400	248.5	11.66	0.44	0.62	0.79	231.5	13.12	0.44	0.63	0.81	214.0	14.75	0.43	0.64	0.83	195.1	16.60	0.42	0.64	0.86

RATINGS

HIGH EFFICIENCY

NOTE - For Temperatures and Capacities not shown in tables, see bulletin - Cooling Unit Rating Table Correction Factor Data in Miscellaneous Engineering Data section.

20 TON HIGH EFFICIENCY KCA240H4B (1ST STAGE) - CONSTANT AIR VOLUME

Entering Wet Bulb Temperature	Total Air Volume	Outdoor Air Temperature Entering Outdoor Coil																			
		65°F					75°F					85°F					95°F				
		Total Cool Cap.	Comp. Motor Input	Sensible To Total Ratio (S/T)			Total Cool Cap.	Comp. Motor Input	Sensible To Total Ratio (S/T)			Total Cool Cap.	Comp. Motor Input	Sensible To Total Ratio (S/T)			Total Cool Cap.	Comp. Motor Input	Sensible To Total Ratio (S/T)		
				Dry Bulb					Dry Bulb					Dry Bulb					Dry Bulb		
cfm	kBtuh	kW	75°F	80°F	85°F	kBtuh	kW	75°F	80°F	85°F	kBtuh	kW	75°F	80°F	85°F	kBtuh	kW	75°F	80°F	85°F	
63°F	6400	130.1	5.15	0.69	0.81	0.94	123.5	5.86	0.69	0.83	0.96	116.6	6.64	0.70	0.84	0.98	109.3	7.52	0.71	0.86	0.99
	8000	137.5	5.20	0.73	0.88	0.99	130.5	5.91	0.74	0.90	1.00	123.1	6.69	0.75	0.92	1.00	115.6	7.57	0.77	0.94	1.00
	9600	143.4	5.25	0.78	0.94	1.00	136.1	5.96	0.79	0.96	1.00	128.4	6.74	0.81	0.98	1.00	120.6	7.62	0.83	0.99	1.00
67°F	6400	139.2	5.22	0.55	0.66	0.78	132.2	5.93	0.55	0.67	0.79	124.7	6.71	0.55	0.68	0.81	117.0	7.58	0.55	0.69	0.83
	8000	146.6	5.27	0.57	0.71	0.85	139.1	5.99	0.58	0.72	0.86	131.3	6.77	0.58	0.73	0.88	123.0	7.64	0.58	0.75	0.91
	9600	152.1	5.31	0.60	0.76	0.91	144.2	6.03	0.61	0.77	0.93	135.9	6.81	0.62	0.79	0.96	127.2	7.68	0.62	0.81	0.98
71°F	6400	148.1	5.28	0.42	0.53	0.64	140.8	6.00	0.42	0.53	0.65	133.2	6.79	0.41	0.54	0.65	125.1	7.66	0.41	0.53	0.66
	8000	155.9	5.34	0.43	0.56	0.69	148.1	6.06	0.43	0.56	0.69	139.8	6.85	0.42	0.57	0.71	131.2	7.73	0.42	0.58	0.73
	9600	161.6	5.39	0.44	0.59	0.73	153.2	6.11	0.44	0.60	0.75	144.7	6.90	0.44	0.61	0.76	135.7	7.77	0.44	0.62	0.78

20 TON HIGH EFFICIENCY KCA240H4B (2ND STAGE) - CONSTANT AIR VOLUME

Entering Wet Bulb Temperature	Total Air Volume	Outdoor Air Temperature Entering Outdoor Coil																			
		85°F					95°F					105°F					115°F				
		Total Cool Cap.	Comp. Motor Input	Sensible To Total Ratio (S/T)			Total Cool Cap.	Comp. Motor Input	Sensible To Total Ratio (S/T)			Total Cool Cap.	Comp. Motor Input	Sensible To Total Ratio (S/T)			Total Cool Cap.	Comp. Motor Input	Sensible To Total Ratio (S/T)		
				Dry Bulb					Dry Bulb					Dry Bulb					Dry Bulb		
cfm	kBtuh	kW	75°F	80°F	85°F	kBtuh	kW	75°F	80°F	85°F	kBtuh	kW	75°F	80°F	85°F	kBtuh	kW	75°F	80°F	85°F	
63°F	6400	236.6	13.31	0.73	0.88	1.00	221.6	15.06	0.74	0.91	1.00	205.8	17.06	0.76	0.94	1.00	189.2	19.35	0.78	0.97	1.00
	8000	249.2	13.43	0.79	0.97	1.00	233.7	15.17	0.80	0.98	1.00	217.5	17.17	0.83	0.99	1.00	201.1	19.47	0.86	1.00	1.00
	9600	260.1	13.53	0.85	1.00	1.00	244.7	15.28	0.87	1.00	1.00	228.9	17.29	0.90	1.00	1.00	212.1	19.59	0.94	1.00	1.00
67°F	6400	252.7	13.46	0.56	0.71	0.85	236.8	15.20	0.57	0.72	0.87	220.0	17.20	0.57	0.73	0.90	202.2	19.48	0.58	0.76	0.93
	8000	264.4	13.57	0.60	0.77	0.93	247.3	15.31	0.61	0.78	0.96	229.6	17.30	0.62	0.81	0.98	210.9	19.57	0.63	0.84	0.99
	9600	272.8	13.66	0.64	0.83	0.99	255.3	15.39	0.64	0.85	1.00	236.8	17.38	0.65	0.88	1.00	217.9	19.65	0.67	0.92	1.00
71°F	6400	269.2	13.62	0.41	0.55	0.68	252.6	15.37	0.41	0.56	0.70	235.2	17.36	0.41	0.56	0.71	216.6	19.64	0.40	0.57	0.73
	8000	281.5	13.75	0.43	0.59	0.74	263.7	15.49	0.43	0.60	0.76	245.0	17.48	0.43	0.61	0.78	225.2	19.74	0.42	0.62	0.81
	9600	289.9	13.83	0.45	0.63	0.81	271.3	15.57	0.45	0.64	0.83	252.0	17.55	0.45	0.65	0.86	231.3	19.81	0.44	0.67	0.89

20 TON HIGH EFFICIENCY KCA240H4M (1ST STAGE) - MSAV® (Multi-Stage Air Volume) SUPPLY AIR BLOWER

Entering Wet Bulb Temperature	Total Air Volume	Outdoor Air Temperature Entering Outdoor Coil																			
		65°F					75°F					85°F					95°F				
		Total Cool Cap.	Comp. Motor Input	Sensible To Total Ratio (S/T)			Total Cool Cap.	Comp. Motor Input	Sensible To Total Ratio (S/T)			Total Cool Cap.	Comp. Motor Input	Sensible To Total Ratio (S/T)			Total Cool Cap.	Comp. Motor Input	Sensible To Total Ratio (S/T)		
				Dry Bulb					Dry Bulb					Dry Bulb					Dry Bulb		
cfm	kBtuh	kW	75°F	80°F	85°F	kBtuh	kW	75°F	80°F	85°F	kBtuh	kW	75°F	80°F	85°F	kBtuh	kW	75°F	80°F	85°F	
63°F	4500	117.1	5.20	0.66	0.75	0.85	111.5	5.97	0.66	0.76	0.86	105.5	6.80	0.66	0.77	0.87	99.20	7.72	0.66	0.78	0.89
	5500	125.0	5.22	0.68	0.80	0.90	118.9	5.99	0.69	0.80	0.92	112.4	6.83	0.69	0.81	0.93	105.6	7.76	0.69	0.83	0.95
	6500	131.1	5.23	0.71	0.83	0.95	124.5	6.01	0.71	0.84	0.97	117.7	6.86	0.72	0.86	0.98	110.6	7.79	0.73	0.88	0.99
67°F	4500	125.7	5.22	0.53	0.63	0.72	119.8	5.99	0.53	0.63	0.73	113.5	6.83	0.52	0.63	0.73	106.9	7.77	0.52	0.63	0.74
	5500	133.9	5.24	0.55	0.66	0.76	127.5	6.02	0.55	0.66	0.77	120.8	6.87	0.54	0.67	0.78	113.7	7.81	0.55	0.67	0.79
	6500	140.2	5.25	0.57	0.69	0.80	133.4	6.04	0.57	0.69	0.81	126.3	6.90	0.56	0.70	0.83	118.6	7.84	0.56	0.71	0.84
71°F	4500	134.2	5.24	0.42	0.51	0.60	128.2	6.02	0.41	0.51	0.61	121.6	6.87	0.41	0.51	0.61	114.6	7.81	0.40	0.50	0.61
	5500	142.9	5.26	0.43	0.53	0.63	136.1	6.05	0.42	0.53	0.64	129.2	6.91	0.41	0.53	0.64	121.7	7.86	0.41	0.53	0.65
	6500	149.4	5.27	0.43	0.55	0.66	142.4	6.07	0.43	0.55	0.67	134.8	6.94	0.43	0.55	0.67	126.8	7.89	0.42	0.55	0.68

20 TON HIGH EFFICIENCY KCA240H4M (2ND STAGE) - MSAV® (Multi-Stage Air Volume) SUPPLY AIR BLOWER

Entering Wet Bulb Temperature	Total Air Volume	Outdoor Air Temperature Entering Outdoor Coil																			
		85°F					95°F					105°F					115°F				
		Total Cool Cap.	Comp. Motor Input	Sensible To Total Ratio (S/T)			Total Cool Cap.	Comp. Motor Input	Sensible To Total Ratio (S/T)			Total Cool Cap.	Comp. Motor Input	Sensible To Total Ratio (S/T)			Total Cool Cap.	Comp. Motor Input	Sensible To Total Ratio (S/T)		
				Dry Bulb					Dry Bulb					Dry Bulb					Dry Bulb		
cfm	kBtuh	kW	75°F	80°F	85°F	kBtuh	kW	75°F	80°F	85°F	kBtuh	kW	75°F	80°F	85°F	kBtuh	kW	75°F	80°F	85°F	
63°F	6400	236.6	13.31	0.73	0.88	1.00	221.6	15.06	0.74	0.91	1.00	205.8	17.06	0.76	0.94	1.00	189.2	19.35	0.78	0.97	1.00
	8000	249.2	13.43	0.79	0.97	1.00	233.7	15.17	0.80	0.98	1.00	217.5	17.17	0.83	0.99	1.00	201.1	19.47	0.86	1.00	1.00
	9600	260.1	13.53	0.85	1.00	1.00	244.7	15.28	0.87	1.00	1.00	228.9	17.29	0.90	1.00	1.00	212.1	19.59	0.94	1.00	1.00
67°F	6400	252.7	13.46	0.56	0.71	0.85	236.8	15.20	0.57	0.72	0.87	220.0	17.20	0.57	0.73	0.90	202.2	19.48	0.58	0.76	0.93
	8000	264.4	13.57	0.60	0.77	0.93	247.3	15.31	0.61	0.78	0.96	229.6	17.30	0.62	0.81	0.98	210.9	19.57	0.63	0.84	0.99
	9600	272.8	13.66	0.64	0.83	0.99	255.3	15.39	0.64	0.85	1.00	236.8	17.38	0.65	0.88	1.00	217.9	19.65	0.67	0.92	1.00
71°F	6400	269.2	13.62	0.41	0.55	0.68	252.6	15.37	0.41	0.56	0.70	235.2	17.36	0.41	0.56	0.71	216.6	19.64	0.40	0.57	0.73
	8000	281.5	13.75	0.43	0.59	0.74	263.7	15.49	0.43	0.60	0.76	245.0	17.48	0.43	0.61	0.78	225.2	19.74	0.42	0.62	0.81
	9600	289.9	13.83	0.45	0.63	0.81	271.3	15.57	0.45	0.64	0.83	252.0	17.55	0.45	0.65	0.86	231.3	19.81	0.44	0.67	0.89

HUMIDITROL® DEHUMIDIFICATION SYSTEM RATINGS

NOTE - For Temperatures and Capacities not shown in tables, see bulletin - Cooling Unit Rating Table Correction Factor Data in Miscellaneous Engineering Data section.

15 TON STANDARD EFFICIENCY KCB180S4 WITH HUMIDITROL® OPERATING (1ST STAGE)

Entering Wet Bulb Temperature	Total Air Volume	Outdoor Air Temperature Entering Outdoor Coil																							
		65°F						75°F						85°F						95°F					
		Total Cool Cap.	Comp. Motor Input	Sensible To Total Ratio (S/T)			Total Cool Cap.	Comp. Motor Input	Sensible To Total Ratio (S/T)			Total Cool Cap.	Comp. Motor Input	Sensible To Total Ratio (S/T)			Total Cool Cap.	Comp. Motor Input	Sensible To Total Ratio (S/T)						
				Dry Bulb					Dry Bulb					Dry Bulb					Dry Bulb						
cfm	kBtuh	kW	75°F	80°F	85°F	kBtuh	kW	75°F	80°F	85°F	kBtuh	kW	75°F	80°F	85°F	kBtuh	kW	75°F	80°F	85°F					
63°F	4695	85.4	5.54	0.56	0.72	0.88	73.1	6.17	0.50	0.71	0.91	60.8	6.79	0.45	0.69	0.93	48.4	7.42	0.40	0.67	0.95				
	5870	90.8	5.55	0.60	0.78	0.94	77.1	6.17	0.55	0.78	0.95	63.5	6.80	0.51	0.78	0.96	49.8	7.42	0.46	0.78	0.98				
	7040	96.2	5.57	0.64	0.84	1.00	81.2	6.18	0.60	0.86	1.00	66.2	6.80	0.56	0.87	1.00	51.2	7.42	0.52	0.89	1.00				
67°F	4695	96.7	5.64	0.38	0.52	0.67	83.4	6.28	0.31	0.47	0.64	70.2	6.92	0.23	0.42	0.61	57.0	7.56	0.16	0.37	0.58				
	5870	99.6	5.64	0.41	0.57	0.73	86.3	6.28	0.32	0.52	0.72	73.0	6.91	0.24	0.48	0.71	59.7	7.55	0.16	0.43	0.71				
	7040	102.5	5.64	0.43	0.61	0.79	89.2	6.28	0.34	0.57	0.81	75.8	6.91	0.25	0.53	0.82	62.5	7.54	0.15	0.50	0.84				
71°F	4695	107.9	5.78	0.24	0.37	0.49	95.2	6.42	0.15	0.30	0.45	82.5	7.06	0.06	0.24	0.41	69.7	7.70	-0.03	0.17	0.38				
	5870	110.0	5.78	0.25	0.39	0.53	97.3	6.42	0.15	0.33	0.50	84.5	7.05	0.06	0.27	0.47	71.7	7.69	-0.03	0.20	0.44				
	7040	112.1	5.79	0.25	0.41	0.57	99.3	6.42	0.15	0.35	0.55	86.5	7.05	0.06	0.29	0.53	73.7	7.68	-0.04	0.24	0.51				

15 TON STANDARD EFFICIENCY KCB180S4 WITH HUMIDITROL® OPERATING (2ND STAGE)

Entering Wet Bulb Temperature	Total Air Volume	Outdoor Air Temperature Entering Outdoor Coil																							
		85°F						95°F						105°F						115°F					
		Total Cool Cap.	Comp. Motor Input	Sensible To Total Ratio (S/T)			Total Cool Cap.	Comp. Motor Input	Sensible To Total Ratio (S/T)			Total Cool Cap.	Comp. Motor Input	Sensible To Total Ratio (S/T)			Total Cool Cap.	Comp. Motor Input	Sensible To Total Ratio (S/T)						
				Dry Bulb					Dry Bulb					Dry Bulb					Dry Bulb						
cfm	kBtuh	kW	75°F	80°F	85°F	kBtuh	kW	75°F	80°F	85°F	kBtuh	kW	75°F	80°F	85°F	kBtuh	kW	75°F	80°F	85°F					
63°F	4695	146.2	8.40	0.61	0.78	0.95	130.3	9.48	0.60	0.80	0.97	114.5	10.56	0.59	0.81	0.99	98.6	11.64	0.58	0.82	1.00				
	5870	153.9	8.43	0.66	0.86	0.98	137.0	9.49	0.66	0.87	0.99	120.1	10.55	0.66	0.88	0.99	103.2	11.61	0.65	0.90	1.00				
	7040	161.6	8.45	0.71	0.93	1.00	143.7	9.49	0.72	0.94	1.00	125.7	10.54	0.72	0.96	1.00	107.8	11.59	0.72	0.97	1.00				
67°F	4695	161.8	8.56	0.45	0.59	0.74	145.3	9.65	0.41	0.58	0.75	128.8	10.75	0.38	0.57	0.76	112.2	11.85	0.35	0.55	0.76				
	5870	168.6	8.57	0.47	0.64	0.82	150.5	9.64	0.45	0.64	0.83	132.4	10.72	0.44	0.64	0.84	114.3	11.80	0.42	0.63	0.85				
	7040	175.4	8.58	0.50	0.70	0.89	155.8	9.63	0.50	0.70	0.91	136.1	10.69	0.49	0.71	0.92	116.5	11.75	0.49	0.71	0.93				
71°F	4695	178.6	8.67	0.29	0.43	0.57	162.1	9.76	0.25	0.41	0.56	145.7	10.85	0.21	0.38	0.55	129.2	11.94	0.17	0.35	0.54				
	5870	183.8	8.69	0.30	0.46	0.62	166.1	9.78	0.26	0.44	0.62	148.4	10.87	0.21	0.41	0.61	130.7	11.96	0.17	0.39	0.61				
	7040	189.0	8.71	0.31	0.49	0.67	170.1	9.80	0.26	0.47	0.67	151.1	10.88	0.22	0.45	0.68	132.2	11.97	0.17	0.43	0.69				

17.5 TON STANDARD EFFICIENCY KCB210S4 WITH HUMIDITROL® OPERATING (1ST STAGE)

Entering Wet Bulb Temperature	Total Air Volume	Outdoor Air Temperature Entering Outdoor Coil																							
		65°F						75°F						85°F						95°F					
		Total Cool Cap.	Comp. Motor Input	Sensible To Total Ratio (S/T)			Total Cool Cap.	Comp. Motor Input	Sensible To Total Ratio (S/T)			Total Cool Cap.	Comp. Motor Input	Sensible To Total Ratio (S/T)			Total Cool Cap.	Comp. Motor Input	Sensible To Total Ratio (S/T)						
				Dry Bulb					Dry Bulb					Dry Bulb					Dry Bulb						
cfm	kBtuh	kW	75°F	80°F	85°F	kBtuh	kW	75°F	80°F	85°F	kBtuh	kW	75°F	80°F	85°F	kBtuh	kW	75°F	80°F	85°F					
63°F	5600	97.6	6.98	0.56	0.73	0.90	82.6	7.80	0.51	0.72	0.93	67.6	8.62	0.46	0.72	0.97	52.6	9.44	0.41	0.71	1.00				
	7000	100.5	7.03	0.60	0.79	0.95	84.5	7.82	0.56	0.79	0.97	68.4	8.62	0.52	0.79	0.98	52.4	9.41	0.47	0.80	1.00				
	8400	103.3	7.08	0.65	0.85	1.00	86.3	7.85	0.62	0.86	1.00	69.3	8.61	0.58	0.87	1.00	52.2	9.37	0.54	0.88	1.00				
67°F	5600	106.4	7.18	0.37	0.52	0.67	92.1	7.99	0.30	0.47	0.65	77.9	8.80	0.22	0.42	0.63	63.6	9.62	0.14	0.38	0.61				
	7000	110.7	7.21	0.41	0.57	0.74	94.5	8.00	0.32	0.53	0.73	78.3	8.79	0.23	0.48	0.72	62.0	9.58	0.15	0.43	0.71				
	8400	115.1	7.24	0.45	0.63	0.81	96.8	8.01	0.35	0.58	0.81	78.6	8.78	0.25	0.53	0.81	60.4	9.55	0.15	0.48	0.81				
71°F	5600	116.4	7.39	0.22	0.35	0.48	102.4	8.20	0.12	0.28	0.44	88.5	9.01	0.02	0.21	0.40	74.6	9.82	-0.08	0.14	0.36				
	7000	115.7	7.33	0.24	0.39	0.54	100.2	8.15	0.13	0.31	0.49	84.7	8.96	0.01	0.23	0.45	69.1	9.78	-0.10	0.15	0.41				
	8400	115.1	7.28	0.26	0.43	0.59	98.0	8.10	0.13	0.34	0.54	80.8	8.92	0.01	0.25	0.50	63.6	9.74	-0.12	0.17	0.46				

17.5 TON STANDARD EFFICIENCY KCB210S4 WITH HUMIDITROL® OPERATING (2ND STAGE)

Entering Wet Bulb Temperature	Total Air Volume	Outdoor Air Temperature Entering Outdoor Coil																							
		85°F						95°F						105°F						115°F					
		Total Cool Cap.	Comp. Motor Input	Sensible To Total Ratio (S/T)			Total Cool Cap.	Comp. Motor Input	Sensible To Total Ratio (S/T)			Total Cool Cap.	Comp. Motor Input	Sensible To Total Ratio (S/T)			Total Cool Cap.	Comp. Motor Input	Sensible To Total Ratio (S/T)						
				Dry Bulb					Dry Bulb					Dry Bulb					Dry Bulb						
cfm	kBtuh	kW	75°F	80°F	85°F	kBtuh	kW	75°F	80°F	85°F	kBtuh	kW	75°F	80°F	85°F	kBtuh	kW	75°F	80°F	85°F					
63°F	5600	170.8	10.71	0.61	0.78	0.94	152.1	12.03	0.60	0.79	0.96	133.5	13.34	0.59	0.81	0.98	114.8	14.66	0.58	0.82	1.00				
	7000	176.8	10.75	0.67	0.85	0.97	156.8	12.09	0.66	0.86	0.98	136.8	13.44	0.65	0.88	0.99	116.8	14.78	0.65	0.90	1.00				
	8400	182.7	10.78	0.73	0.91	1.00	161.5	12.16	0.72	0.93	1.00	140.2	13.53	0.72	0.95	1.00	118.9	14.91	0.71	0.97	1.00				
67°F	5600	183.1	10.94	0.44	0.59	0.74	165.0	12.29	0.41	0.58	0.75	146.9	13.65	0.37	0.57	0.76	128.8	15.00	0.34	0.56	0.78				
	7000	184.6	11.02	0.48	0.65	0.82	166.1	12.36	0.44	0.64	0.84	147.5	13.69	0.41	0.63	0.86	129.0	15.02	0.37	0.62	0.88				
	8400	186.1	11.11	0.51	0.71	0.90	167.1	12.42	0.48	0.70	0.93	148.1	13.73	0.44	0.70	0.95	129.1	15.04	0.40	0.69	0.98				
71°F	5600	198.5	11.09	0.29	0.43	0.57	180.2	12.52	0.24	0.40	0.56	162.0	13.96	0.19	0.37	0.54	143.7	15.39	0.14	0.33	0.52				
	7000	196.6	11.21	0.31	0.47	0.63	178.8	12.59	0.26	0.44	0.62	161.1	13.97	0.20	0.40	0.60	143.3	15.36	0.15	0.37	0.59				
	8400	194.6	11.33	0.33	0.51	0.69	177.4	12.66	0.27	0.47	0.68	160.2	13.99	0.21	0.44	0.66	143.0	15.32	0.15	0.40	0.65				

HUMIDITROL® DEHUMIDIFICATION SYSTEM RATINGS

NOTE - For Temperatures and Capacities not shown in tables, see bulletin - Cooling Unit Rating Table Correction Factor Data in Miscellaneous Engineering Data section.

20 TON STANDARD EFFICIENCY KCB240S4 WITH HUMIDITROL® OPERATING (1ST STAGE)

Entering Wet Bulb Temperature	Total Air Volume	Outdoor Air Temperature Entering Outdoor Coil																			
		65°F						75°F					85°F					95°F			
		Total Cool Cap.	Comp. Motor Input	Sensible To Total Ratio (S/T)			Total Cool Cap.	Comp. Motor Input	Sensible To Total Ratio (S/T)			Total Cool Cap.	Comp. Motor Input	Sensible To Total Ratio (S/T)			Total Cool Cap.	Comp. Motor Input	Sensible To Total Ratio (S/T)		
				Dry Bulb					Dry Bulb					Dry Bulb					Dry Bulb		
cfm	kBtuh	kW	75°F	80°F	85°F	kBtuh	kW	75°F	80°F	85°F	kBtuh	kW	75°F	80°F	85°F	kBtuh	kW	75°F	80°F	85°F	
63°F	6135	106.5	8.12	0.57	0.74	0.91	91.4	8.95	0.53	0.73	0.94	76.4	9.78	0.48	0.73	0.97	61.4	10.61	0.44	0.72	1.000
	7665	107.7	8.15	0.59	0.81	0.96	90.5	8.98	0.63	0.82	0.96	73.4	9.81	0.68	0.84	0.97	56.3	10.64	0.72	0.86	0.983
	9200	108.9	8.17	0.60	0.87	1.00	89.7	9.00	0.73	0.92	0.99	70.5	9.84	0.87	0.96	0.98	51.3	10.68	1.00	1.00	0.966
67°F	6135	113.8	8.30	0.39	0.57	0.747	100.5	9.14	0.29	0.51	0.73	87.2	9.98	0.20	0.45	0.71	73.8	10.82	0.11	0.40	0.69
	7665	120.5	8.31	0.39	0.58	0.772	103.7	9.13	0.29	0.54	0.78	87.0	9.95	0.19	0.49	0.79	70.2	10.77	0.09	0.44	0.80
	9200	127.1	8.32	0.39	0.60	0.798	106.9	9.12	0.29	0.56	0.84	86.7	9.92	0.18	0.53	0.87	66.5	10.72	0.07	0.49	0.91
71°F	6135	123.9	8.43	0.23	0.39	0.55	111.0	9.31	0.13	0.32	0.51	98.0	10.18	0.03	0.25	0.46	85.1	11.06	-0.07	0.18	0.42
	7665	130.1	8.43	0.23	0.40	0.57	114.0	9.29	0.13	0.33	0.54	97.9	10.16	0.03	0.26	0.50	81.8	11.02	-0.08	0.19	0.46
	9200	136.3	8.42	0.23	0.41	0.59	117.0	9.28	0.12	0.34	0.56	97.7	10.13	0.02	0.28	0.54	78.4	10.99	-0.09	0.21	0.51

20 TON STANDARD EFFICIENCY KCB240S4 WITH HUMIDITROL® OPERATING (2ND STAGE)

Entering Wet Bulb Temperature	Total Air Volume	Outdoor Air Temperature Entering Outdoor Coil																			
		85°F						95°F					105°F					115°F			
		Total Cool Cap.	Comp. Motor Input	Sensible To Total Ratio (S/T)			Total Cool Cap.	Comp. Motor Input	Sensible To Total Ratio (S/T)			Total Cool Cap.	Comp. Motor Input	Sensible To Total Ratio (S/T)			Total Cool Cap.	Comp. Motor Input	Sensible To Total Ratio (S/T)		
				Dry Bulb					Dry Bulb					Dry Bulb					Dry Bulb		
cfm	kBtuh	kW	75°F	80°F	85°F	kBtuh	kW	75°F	80°F	85°F	kBtuh	kW	75°F	80°F	85°F	kBtuh	kW	75°F	80°F	85°F	
63°F	6135	193.8	13.08	0.63	0.78	0.94	172.5	14.55	0.61	0.80	0.96	151.2	16.01	0.59	0.82	0.98	129.9	17.48	0.58	0.84	1.00
	7665	196.2	13.18	0.66	0.84	0.97	175.8	14.63	0.66	0.86	0.98	155.4	16.07	0.65	0.88	0.99	135.0	17.51	0.65	0.90	1.00
	9200	198.6	13.29	0.69	0.91	1.00	179.1	14.71	0.70	0.92	1.00	159.5	16.13	0.71	0.93	1.00	140.0	17.55	0.73	0.95	1.00
67°F	6135	203.6	13.36	0.48	0.61	0.73	187.0	14.86	0.44	0.59	0.74	170.5	16.35	0.40	0.57	0.75	154.0	17.85	0.36	0.56	0.75
	7665	207.9	13.41	0.49	0.64	0.79	190.1	14.88	0.46	0.64	0.82	172.2	16.36	0.42	0.63	0.84	154.3	17.83	0.38	0.63	0.87
	9200	212.3	13.46	0.50	0.68	0.86	193.1	14.91	0.47	0.69	0.90	173.8	16.36	0.44	0.69	0.94	154.6	17.81	0.41	0.70	0.98
71°F	6135	221.9	13.72	0.31	0.44	0.56	203.9	15.20	0.26	0.41	0.56	185.9	16.67	0.22	0.39	0.56	167.9	18.15	0.169	0.36	0.56
	7665	224.1	13.68	0.32	0.46	0.59	205.4	15.17	0.27	0.43	0.60	186.8	16.67	0.22	0.41	0.60	168.1	18.16	0.177	0.39	0.60
	9200	226.4	13.64	0.33	0.48	0.63	207.0	15.15	0.28	0.46	0.63	187.6	16.66	0.23	0.43	0.64	168.2	18.17	0.186	0.41	0.64

25 TON STANDARD EFFICIENCY KCB300S4 WITH HUMIDITROL® OPERATING (1ST STAGE)

Entering Wet Bulb Temperature	Total Air Volume	Outdoor Air Temperature Entering Outdoor Coil																			
		65°F						75°F					85°F					95°F			
		Total Cool Cap.	Comp. Motor Input	Sensible To Total Ratio (S/T)			Total Cool Cap.	Comp. Motor Input	Sensible To Total Ratio (S/T)			Total Cool Cap.	Comp. Motor Input	Sensible To Total Ratio (S/T)			Total Cool Cap.	Comp. Motor Input	Sensible To Total Ratio (S/T)		
				Dry Bulb					Dry Bulb					Dry Bulb					Dry Bulb		
cfm	kBtuh	kW	75°F	80°F	85°F	kBtuh	kW	75°F	80°F	85°F	kBtuh	kW	75°F	80°F	85°F	kBtuh	kW	75°F	80°F	85°F	
63°F	8000	100.4	7.25	.55	.74	.93	83.6	7.96	.47	.71	.96	66.7	8.67	.38	.69	.99	49.8	9.38	.29	.66	1.00
	9500	106.3	7.33	.58	.77	.97	89.3	8.02	.50	.76	.99	72.3	8.71	.42	.74	1.00	55.2	9.40	.34	.72	1.00
	11,000	112.2	7.40	.61	.81	.99	95.0	8.08	.53	.80	1.00	77.8	8.75	.46	.80	1.00	60.6	9.43	.38	.79	1.00
67°F	8000	116.1	7.40	.37	.54	.71	98.8	8.14	.27	.48	.70	81.5	8.87	.17	.43	.69	64.2	9.61	.07	.37	.68
	9500	106.3	7.33	.58	.77	.97	89.3	8.02	.50	.76	.99	72.3	8.71	.42	.74	1.00	55.2	9.40	.34	.72	1.00
	11,000	129.2	7.52	.40	.58	.77	109.6	8.24	.30	.54	.78	90.1	8.95	.20	.50	.80	70.5	9.66	.09	.46	.82
71°F	8000	131.7	7.55	.19	.34	.49	114.0	8.31	.07	.25	.44	96.3	9.07	-.04	.17	.38	78.6	9.83	-.16	.09	.33
	9500	139.0	7.60	.19	.35	.51	119.1	8.36	.07	.27	.46	99.3	9.11	-.06	.19	.43	79.5	9.86	-.18	.11	.38
	11,000	146.2	7.65	.19	.36	.52	124.2	8.40	.07	.28	.49	102.3	9.14	-.07	.20	.47	80.4	9.89	-.20	.12	.44

25 TON STANDARD EFFICIENCY KCB300S4 WITH HUMIDITROL® OPERATING (2ND STAGE)

Entering Wet Bulb Temperature	Total Air Volume	Outdoor Air Temperature Entering Outdoor Coil																			
		85°F						95°F					105°F					115°F			
		Total Cool Cap.	Comp. Motor Input	Sensible To Total Ratio (S/T)			Total Cool Cap.	Comp. Motor Input	Sensible To Total Ratio (S/T)			Total Cool Cap.	Comp. Motor Input	Sensible To Total Ratio (S/T)			Total Cool Cap.	Comp. Motor Input	Sensible To Total Ratio (S/T)		
				Dry Bulb					Dry Bulb					Dry Bulb					Dry Bulb		
cfm	kBtuh	kW	75°F	80°F	85°F	kBtuh	kW	75°F	80°F	85°F	kBtuh	kW	75°F	80°F	85°F	kBtuh	kW	75°F	80°F	85°F	
63°F	8000	260.3	14.9	.66	.80	.95	234.7	16.7	.65	.81	.97	209.1	18.5	.65	.82	.98	183.5	20.3	.65	.82	1.00
	9500	276.4	15.0	.69	.83	.96	248.2	16.8	.70	.84	.97	220.1	18.6	.70	.85	.99	191.9	20.4	.71	.85	1.00
	11,000	279.6	15.1	.73	.87	1.00	253.1	16.9	.75	.87	1.00	226.7	18.7	.76	.88	1.00	200.3	20.5	.78	.89	1.00
67°F	8000	283.9	15.2	.50	.64	.78	257.7	17.0	.48	.63	.79	231.5	18.8	.46	.63	.80	205.3	20.7	.44	.62	.81
	9500	294.1	15.3	.52	.67	.81	266.7	17.1	.51	.66	.82	239.3	18.9	.49	.66	.82	211.9	20.8	.48	.66	.83
	11,000	302.0	15.4	.54	.69	.84	274.2	17.2	.53	.69	.85	246.3	19.1	.53	.69	.86	218.4	20.9	.52	.69	.87
71°F	8000	307.5	15.5	.34	.47	.61	280.7	17.3	.31	.46	.61	253.9	19.2	.27	.44	.61	227.2	21.1	.24	.43	.61
	9500	311.7	15.5	.35	.51	.66	285.1	17.4	.32	.49	.66	258.5	19.3	.28	.47	.66	231.9	21.2	.25	.46	.66
	11,000	324.5	15.6	.35	.51	.67	295.2	17.5	.32	.51	.69	265.9	19.4	.29	.50	.71	236.6	21.3	.26	.50	.73

BLOWER DATA

BLOWER TABLE INCLUDES RESISTANCE FOR BASE UNIT ONLY WITH DRY INDOOR COIL & AIR FILTERS IN PLACE

FOR ALL UNITS ADD:

- 1 - Wet indoor coil air resistance of selected unit.
- 2 - Any factory installed options air resistance (electric heat, economizer, etc.)
- 3 - Any field installed accessories air resistance (electric heat, duct resistance, diffuser, etc.)

Then determine from blower table blower motor output and drive required.

See page 33 for wet coil and option/accessory air resistance data.

See page 33 for factory installed drive kit specifications.

MINIMUM AIR VOLUME REQUIRED FOR USE WITH OPTIONAL ELECTRIC HEAT

KCA156H units require 5200 cfm minimum air with electric heat.

All other units require 6000 cfm minimum air with electric heat.

Air Volume cfm	TOTAL STATIC PRESSURE - Inches Water Gauge (Pa)																											
	0.20		0.40		0.60		0.80		1.00		1.20		1.40		1.60		1.80		2.00		2.20		2.40		2.60			
	RPM	BHP	RPM	BHP	RPM	BHP	RPM	BHP	RPM	BHP	RPM	BHP	RPM	BHP	RPM	BHP	RPM	BHP	RPM	BHP	RPM	BHP	RPM	BHP	RPM	BHP		
2750	385	0.30	505	0.50	600	0.70	680	0.90	755	1.10	820	1.30	885	1.50	950	1.70	1005	1.90	1060	2.10	1115	2.30	1170	2.50	1225	2.70	1280	2.90
3000	395	0.35	515	0.55	610	0.75	685	1.00	760	1.20	825	1.45	890	1.65	955	1.85	1015	2.05	1070	2.25	1125	2.45	1180	2.65	1235	2.85	1290	3.05
3250	405	0.40	520	0.60	615	0.85	695	1.10	765	1.30	830	1.60	895	1.80	955	2.00	1010	2.20	1065	2.40	1120	2.60	1175	2.80	1230	3.00	1285	3.20
3500	415	0.45	530	0.70	620	0.95	700	1.20	775	1.45	840	1.70	900	1.90	955	2.10	1010	2.30	1065	2.50	1120	2.70	1175	2.90	1230	3.10	1285	3.30
3750	425	0.50	540	0.75	630	1.05	710	1.30	785	1.60	845	1.85	905	2.05	960	2.25	1015	2.45	1070	2.65	1125	2.85	1180	3.05	1235	3.25	1290	3.45
4000	435	0.55	545	0.85	635	1.10	715	1.40	785	1.70	850	2.00	910	2.20	965	2.40	1020	2.60	1075	2.80	1130	3.00	1185	3.20	1240	3.40	1295	3.60
4250	445	0.60	555	0.90	645	1.25	725	1.55	795	1.85	855	2.15	915	2.35	970	2.55	1025	2.75	1080	2.95	1135	3.15	1190	3.35	1245	3.55	1300	3.75
4500	455	0.70	565	1.00	655	1.35	730	1.65	800	2.00	865	2.35	925	2.55	980	2.75	1035	2.95	1090	3.15	1145	3.35	1200	3.55	1255	3.75	1310	3.95
4750	470	0.75	575	1.10	660	1.45	740	1.80	810	2.15	870	2.50	930	2.70	985	2.90	1040	3.10	1095	3.30	1150	3.50	1205	3.70	1260	3.90	1315	4.10
5000	480	0.85	585	1.25	670	1.60	750	1.95	815	2.30	880	2.70	940	2.90	995	3.10	1050	3.30	1105	3.50	1160	3.70	1215	3.90	1270	4.10	1325	4.30
5250	495	0.95	595	1.35	680	1.70	755	2.10	825	2.50	890	2.90	945	3.10	1000	3.30	1055	3.50	1110	3.70	1165	3.90	1220	4.10	1275	4.30	1330	4.50
5500	505	1.05	605	1.45	690	1.85	765	2.25	835	2.65	895	3.05	955	3.25	1010	3.45	1065	3.65	1120	3.85	1175	4.05	1230	4.25	1285	4.45	1340	4.65
5750	520	1.15	615	1.60	700	2.00	775	2.45	840	2.85	905	3.25	960	3.45	1015	3.65	1070	3.85	1125	4.05	1180	4.25	1235	4.45	1290	4.65	1345	4.85
6000	530	1.30	630	1.75	710	2.15	785	2.60	850	3.05	910	3.45	970	3.65	1025	3.85	1080	4.05	1135	4.25	1190	4.45	1245	4.65	1300	4.85	1355	5.05
6250	545	1.40	640	1.90	720	2.35	795	2.80	860	3.25	920	3.70	985	3.90	1035	4.10	1090	4.30	1145	4.50	1200	4.70	1255	4.90	1310	5.10	1365	5.30
6500	560	1.55	650	2.05	730	2.50	805	3.00	870	3.45	930	3.95	995	4.15	1045	4.35	1100	4.55	1155	4.75	1210	4.95	1265	5.15	1320	5.35	1375	5.55
6750	570	1.70	665	2.20	745	2.70	815	3.20	880	3.70	940	4.20	1005	4.40	1055	4.60	1110	4.80	1165	5.00	1220	5.20	1275	5.40	1330	5.60	1385	5.80
7000	585	1.85	675	2.35	755	2.90	825	3.40	890	3.95	950	4.45	1015	4.65	1065	4.85	1120	5.05	1175	5.25	1230	5.45	1285	5.65	1340	5.85	1395	6.05
7250	600	2.00	690	2.60	765	3.10	835	3.65	900	4.15	955	4.65	1015	4.85	1065	5.05	1120	5.25	1175	5.45	1230	5.65	1285	5.85	1340	6.05	1395	6.25
7500	615	2.20	700	2.75	775	3.30	845	3.85	910	4.45	965	4.95	1020	5.10	1075	5.30	1130	5.50	1185	5.70	1240	5.90	1295	6.10	1350	6.30	1405	6.50
7750	630	2.40	715	3.00	790	3.55	855	4.10	920	4.70	975	5.25	1030	5.45	1085	5.65	1140	5.85	1195	6.05	1250	6.25	1305	6.45	1360	6.65	1415	6.85
8000	640	2.55	725	3.20	800	3.80	865	4.35	930	4.95	985	5.50	1040	5.70	1095	5.90	1150	6.10	1205	6.30	1260	6.50	1315	6.70	1370	6.90	1425	7.10
8250	655	2.80	740	3.40	810	4.00	880	4.65	940	5.25	995	5.85	1050	6.05	1105	6.25	1160	6.45	1215	6.65	1270	6.85	1325	7.05	1380	7.25	1435	7.45
8500	670	3.00	750	3.65	825	4.30	890	4.90	950	5.55	1005	6.15	1060	6.35	1115	6.55	1170	6.75	1225	6.95	1280	7.15	1335	7.35	1390	7.55	1445	7.75
8750	685	3.25	765	3.90	835	4.55	900	5.20	960	5.85	1015	6.45	1070	6.65	1125	6.85	1180	7.05	1235	7.25	1290	7.45	1345	7.65	1400	7.85	1455	8.05
9000	700	3.50	780	4.20	850	4.85	910	5.50	970	6.15	1025	6.80	1080	7.05	1135	7.25	1190	7.45	1245	7.65	1300	7.85	1355	8.05	1410	8.25	1465	8.45
9250	715	3.75	790	4.45	860	5.15	925	5.85	985	6.55	1040	7.20	1095	7.45	1150	7.65	1205	7.85	1260	8.05	1315	8.25	1370	8.45	1425	8.65	1480	8.85
9500	730	4.00	805	4.75	875	5.45	935	6.15	995	6.90	1050	7.60	1105	7.85	1160	8.05	1215	8.25	1270	8.45	1325	8.65	1380	8.85	1435	9.05	1490	9.25
9750	745	4.30	820	5.05	885	5.75	950	6.55	1005	7.20	1060	7.95	1115	8.15	1170	8.35	1225	8.55	1280	8.75	1335	8.95	1390	9.15	1445	9.35	1500	9.55
10,000	760	4.60	835	5.40	900	6.15	960	6.85	1015	7.60	1070	8.35	1120	8.55	1175	8.75	1230	8.95	1285	9.15	1340	9.35	1395	9.55	1450	9.75	1505	9.95
10,250	775	4.90	845	5.65	910	6.45	970	7.20	1030	8.00	1080	8.75	1135	8.95	1190	9.15	1245	9.35	1300	9.55	1355	9.75	1410	9.95	1465	10.15	1515	10.35
10,500	790	5.20	860	6.00	925	6.85	985	7.65	1040	8.40	1095	9.20	1145	9.45	1200	9.65	1255	9.85	1310	10.05	1365	10.25	1420	10.45	1475	10.65	1525	10.85
10,750	805	5.55	875	6.40	940	7.25	1000	8.05	1055	8.85	1105	9.65	1155	9.85	1210	10.05	1265	10.25	1320	10.45	1375	10.65	1430	10.85	1485	11.05	1535	11.25
11,000	820	5.90	890	6.80	950	7.60	1010	8.45	1065	9.30	1115	10.05	1165	10.25	1220	10.45	1275	10.65	1330	10.85	1385	11.05	1440	11.25	1495	11.45	1545	11.65

BLOWER DATA

FACTORY INSTALLED BELT DRIVE KIT SPECIFICATIONS

Motor Efficiency	Nominal hp	Maximum hp	Drive Kit Number	RPM Range
Standard or High	2	2.30	1	535 - 725
Standard or High	2	2.30	2	710 - 965
Standard	3	3.45	1	535 - 725
Standard	3	3.45	2	710 - 965
Standard	5	5.75	3	685 - 856
Standard	5	5.75	4	850 - 1045
Standard	5	5.75	5	945 - 1185
Standard	7.5	8.63	6	850 - 1045
Standard	7.5	8.63	7	945 - 1185
Standard	7.5	8.63	8	1045 - 1285
Standard	10	11.50	7	945 - 1185
Standard	10	11.50	10	1045 - 1285
Standard	10	11.50	11	1135 - 1365

NOTE - Using total air volume and system static pressure requirements determine from blower performance tables rpm and motor output required. Maximum usable output of motors furnished are shown. In Canada, nominal motor output is also maximum usable motor output. If motors of comparable output are used, be sure to keep within the service factor limitations outlined on the motor nameplate.

NOTE - Units equipped with MSAV® (Multi-Stage Air Volume) are limited to a motor service factor of 1.0.

FACTORY INSTALLED OPTIONS/FIELD INSTALLED ACCESSORY AIR RESISTANCE - in w.g.

Air Volume cfm	Wet Indoor Coil		Humiditrol® Condenser Reheat Coil	Electric Heat	Economizer	Filters		Horizontal Roof Curb	
	156H 180S 180H	210S 210H 240H 240S 300S				MERV 8	MERV 13	156H thru 240H	300S
2750	.01	.02	.01	---	---	.01	.03	.03	-
3000	.01	.02	.01	---	---	.01	.03	.04	-
3250	.01	.03	.01	---	---	.01	.04	.04	.01
3500	.01	.03	.02	---	---	.01	.04	.05	.01
3750	.01	.03	.02	---	---	.01	.04	.05	.01
4000	.02	.04	.02	---	---	.01	.04	.06	.02
4250	.02	.04	.02	---	---	.01	.05	.07	.02
4500	.02	.05	.02	---	---	.01	.05	.07	.02
4750	.02	.05	.02	---	---	.02	.05	.08	.03
5000	.02	.05	.02	---	---	.02	.06	.08	.03
5250	.02	.06	.03	---	---	.02	.06	.09	.04
5500	.02	.07	.03	---	---	.02	.06	.10	.04
5750	.03	.07	.03	---	---	.02	.07	.11	.05
6000	.03	.08	.03	.01	---	.03	.07	.11	.06
6250	.03	.08	.03	.01	.01	.03	.07	.12	.07
6500	.03	.09	.04	.01	.02	.03	.08	.13	.08
6750	.04	.10	.04	.01	.03	.03	.08	.14	.08
7000	.04	.10	.04	.01	.04	.04	.08	.15	.09
7250	.04	.11	.04	.01	.05	.04	.09	.16	.10
7500	.05	.12	.05	.01	.06	.04	.09	.17	.11
8000	.05	.13	.05	.02	.09	.05	.10	.19	.13
8500	.06	.15	.05	.02	.11	.05	.10	.21	.15
9000	.07	.16	.06	.04	.14	.06	.11	.24	.17
9500	.08	.18	.07	.05	.16	.07	.12	.26	.19
10,000	.08	.20	.07	.06	.19	.07	.12	.29	.21
10,500	.09	.22	.08	.09	.22	.08	.13	.31	.24
11,000	.11	.24	.08	.11	.25	.09	.14	.34	.27

BLOWER DATA

CEILING DIFFUSER AIR RESISTANCE - in. w.g.

Air Volume cfm	Step-Down Diffuser						Flush Diffuser	
	RTD11-185S			RTD11-275S			FD11-185S	FD11-275S
	2 Ends Open	1 Side/2 Ends Open	All Ends & Sides Open	2 Ends Open	1 Side/2 Ends Open	All Ends & Sides Open		
5000	.51	.44	.39	---	---	---	.27	---
5200	.56	.48	.42	---	---	---	.30	---
5400	.61	.52	.45	---	---	---	.33	---
5600	.66	.56	.48	---	---	---	.36	---
5800	.71	.59	.51	---	---	---	.39	---
6000	.76	.63	.55	.36	.31	.27	.42	.29
6200	.80	.68	.59	---	---	---	.46	---
6400	.86	.72	.63	---	---	---	.50	---
6500	---	---	---	.42	.36	.31	---	.34
6600	.92	.77	.67	---	---	---	.54	---
6800	.99	.83	.72	---	---	---	.58	---
7000	1.03	.87	.76	.49	.41	.36	.62	.40
7200	1.09	.92	.80	---	---	---	.66	---
7400	1.15	.97	.84	---	---	---	.70	---
7500	---	---	---	.51	.46	.41	---	.45
7600	1.20	1.02	.88	---	---	---	.74	---
8000	---	---	---	.59	.49	.43	---	.50
8500	---	---	---	.69	.58	.50	---	.57
9000	---	---	---	.79	.67	.58	---	.66
9500	---	---	---	.89	.75	.65	---	.74
10,000	---	---	---	1.00	.84	.73	---	.81
10,500	---	---	---	1.10	.92	.80	---	.89
11,000	---	---	---	1.21	1.01	.88	---	.96

CEILING DIFFUSER AIR THROW DATA

Model No.	Air Volume cfm	¹ Effective Throw Range - ft.		Model No.	Air Volume cfm	¹ Effective Throw Range - ft.	
		RTD11-185S Step-Down	FD11-185S Flush			RTD11-275S Step-Down	FD11-275S Flush
156 180	5600	39 - 49	28 - 37	210 240 300	7200	33 - 38	26 - 35
	5800	42 - 51	29 - 38		7400	35 - 40	28 - 37
	6000	44 - 54	40 - 50		7600	36 - 41	29 - 38
	6200	45 - 55	42 - 51		7800	38 - 43	40 - 50
	6400	46 - 55	43 - 52		8000	39 - 44	42 - 51
	6600	47 - 56	45 - 56		8200	41 - 46	43 - 52
					8400	43 - 49	44 - 54
					8600	44 - 50	46 - 57
					8800	47 - 55	48 - 59

¹ Throw is the horizontal or vertical distance an airstream travels on leaving the outlet or diffuser before the maximum velocity is reduced to 50 ft. per minute. Four sides open.

POWER EXHAUST FAN PERFORMANCE

Return Air System Static Pressure	Air Volume Exhausted
in. w.g.	cfm
0.00	8630
0.05	8210
0.10	7725
0.15	7110
0.20	6470
0.25	5790
0.30	5060
0.35	4300
0.40	3510
0.45	2690
0.50	1840

ELECTRICAL/ELECTRIC HEAT DATA

STANDARD EFFICIENCY - 15 TON

KCB180S4

¹ Voltage - 60hz		208/230V - 3 Ph			460V - 3 Ph			575V - 3 Ph		
Compressor 1	Rated Load Amps	13.2			6.3			4.9		
	Locked Rotor Amps	93			60			41		
Compressor 2	Rated Load Amps	13.2			6.3			4.9		
	Locked Rotor Amps	93			60			41		
Compressor 3	Rated Load Amps	13.2			6.3			4.9		
	Locked Rotor Amps	93			60			41		
Outdoor Fan Motors (3)	Full Load Amps	2.4			1.3			1		
	(total)	(7.2)			(3.9)			(3)		
Power Exhaust (2) 0.33 HP	Full Load Amps	2.4			1.3			1		
	(total)	(4.8)			(2.6)			(2)		
Service Outlet 115V GFI (amps)		15			15			20		
Indoor Blower Motor	Horsepower	3	5	7.5	3	5	7.5	3	5	7.5
	Full Load Amps	10.6	16.7	24.2	4.8	7.6	11	3.9	6.1	9
² Maximum Overcurrent Protection	Unit Only	70	80	100	35	35	45	25	30	35
	With (2) 0.33 HP Power Exhaust	70	80	100	35	40	50	25	30	35
³ Minimum Circuit Ampacity	Unit Only	61	68	78	30	33	37	23	26	29
	With (2) 0.33 HP Power Exhaust	66	72	82	32	35	40	25	28	31

ELECTRIC HEAT DATA

Electric Heat Voltage			208V	240V	208V	240V	208V	240V	480V	480V	480V	600V	600V	600V
² Maximum Overcurrent Protection	Unit+ Electric Heat	15 kW	70	70	80	80	100	100	35	35	45	25	30	35
		30 kW	100	110	100	125	110	125	60	60	60	45	45	50
		45 kW	150	150	150	175	150	175	80	80	90	60	70	70
		60 kW	150	175	150	175	175	175	80	90	90	70	70	70
³ Minimum Circuit Ampacity	Unit+ Electric Heat	15 kW	61	61	68	68	78	78	30	33	37	23	26	30
		30 kW	92	104	100	112	109	121	52	55	59	41	44	48
		45 kW	131	149	139	157	148	166	74	78	82	60	62	66
		60 kW	139	158	146	166	156	175	79	82	86	63	66	69
² Maximum Overcurrent Protection	Unit+ Electric Heat and (2) 0.33 HP Power Exhaust	15 kW	70	70	80	80	100	100	35	40	50	30	30	35
		30 kW	100	110	110	125	125	150	60	60	70	45	50	50
		45 kW	150	175	150	175	175	175	80	90	90	70	70	70
		60 kW	150	175	175	175	175	200	90	90	90	70	70	80
³ Minimum Circuit Ampacity	Unit+ Electric Heat and (2) 0.33 HP Power Exhaust	15 kW	66	66	72	72	82	82	32	36	40	26	29	32
		30 kW	98	110	106	118	115	127	55	58	63	44	47	50
		45 kW	137	155	145	163	154	172	77	81	85	62	65	68
		60 kW	145	164	152	172	162	181	82	85	90	66	68	72

ELECTRICAL ACCESSORIES

Disconnect	Unit Only	54W85	54W85	54W85	54W85	54W85	54W85	54W85	54W85	54W85	54W85	54W85	54W85	54W85
	Unit + Power Exhaust	54W85	54W85	54W85	54W85	54W86	54W86	54W85	54W85	54W85	54W85	54W85	54W85	54W85
	Unit + Electric Heat 15 kW	54W85	54W85	54W85	54W85	54W85	54W85	54W85	54W85	54W85	54W85	54W85	54W85	54W85
	Unit + Electric Heat 30 kW	54W86	54W86	54W86	54W86	54W86	54W86	54W85	54W85	54W85	54W85	54W85	54W85	54W85
	Unit + Electric Heat 45 kW	54W86	54W86	54W86	54W86	54W87	54W87	54W85	54W85	54W85	54W85	54W85	54W85	54W85
	Unit + Electric Heat 60 kW	54W87	54W87	54W87	54W87	54W87	54W87	54W86	54W86	54W86	54W85	54W85	54W85	54W85
	Unit + Power Exhaust + Elec. Heat 15 kW	54W85	54W85	54W85	54W85	54W86	54W86	54W85	54W85	54W85	54W85	54W85	54W85	54W85
	Unit + Power Exhaust + Elec. Heat 30 kW	54W86	54W86	54W86	54W86	54W86	54W86	54W85	54W85	54W85	54W85	54W85	54W85	54W85
	Unit + Power Exhaust + Elec. Heat 45 kW	54W86	54W86	54W86	54W86	54W87	54W87	54W85	54W85	54W85	54W85	54W85	54W85	54W85
	Unit + Power Exhaust + Elec. Heat 60 kW	54W87	54W87	54W87	54W87	54W87	54W87	54W86	54W86	54W86	54W85	54W85	54W85	54W85

NOTE - All units have a minimum Short Circuit Current Rating (SCCR) of 5000 amps.

¹ Extremes of operating range are plus and minus 10% of line voltage.

² HACR type breaker or fuse.

³ Refer to National or Canadian Electrical Code manual to determine wire, fuse and disconnect size requirements.

ELECTRICAL/ELECTRIC HEAT DATA

STANDARD EFFICIENCY - 17.5 TON

KCB210S4

¹ Voltage - 60hz		208/230V - 3 Ph			460V - 3 Ph			575V - 3 Ph		
Compressor 1	Rated Load Amps	19.6			8.2			6.6		
	Locked Rotor Amps	136			66.1			55.3		
Compressor 2	Rated Load Amps	19.6			8.2			6.6		
	Locked Rotor Amps	136			66.1			55.3		
Compressor 3	Rated Load Amps	19.6			8.2			6.6		
	Locked Rotor Amps	136			66.1			55.3		
Outdoor Fan Motors (3)	Full Load Amps	2.4			1.3			1		
	(total)	(7.2)			(3.9)			(3)		
Power Exhaust (2) 0.33 HP	Full Load Amps	2.4			1.3			1		
	(total)	(4.8)			(2.6)			(2)		
Service Outlet 115V GFI (amps)		15			15			20		
Indoor Blower Motor	Horsepower	3	5	7.5	3	5	7.5	3	5	7.5
	Full Load Amps	10.6	16.7	24.2	4.8	7.6	11	3.9	6.1	9
² Maximum Overcurrent Protection	Unit Only	100	100	110	40	45	50	30	35	40
	With (2) 0.33 HP Power Exhaust	100	110	125	45	45	50	35	35	45
³ Minimum Circuit Ampacity	Unit Only	82	88	97	36	39	43	29	31	35
	With (2) 0.33 HP Power Exhaust	87	93	102	38	41	45	31	33	37

ELECTRIC HEAT DATA

Electric Heat Voltage			208V	240V	208V	240V	208V	240V	480V	480V	480V	600V	600V	600V
² Maximum Overcurrent Protection	Unit+ Electric Heat and (2) 0.33 HP Power Exhaust	15 kW	100	100	100	100	110	110	40	45	50	30	35	40
		30 kW	100	110	100	125	110	125	60	60	60	45	45	50
		45 kW	150	150	150	175	150	175	80	80	90	60	70	70
		60 kW	150	175	150	175	175	175	80	90	90	70	70	70
		90 kW	225	250	225	250	225	250	125	125	125	100	100	100
³ Minimum Circuit Ampacity	Unit+ Electric Heat and (2) 0.33 HP Power Exhaust	15 kW	82	82	88	88	97	97	36	39	43	29	31	35
		30 kW	92	104	100	112	109	121	52	55	59	41	44	48
		45 kW	131	149	139	157	148	166	74	78	82	60	62	66
		60 kW	139	158	146	166	156	175	79	82	86	63	66	69
		90 kW	201	230	209	238	218	247	115	118	123	92	95	98
² Maximum Overcurrent Protection	Unit+ Electric Heat and (2) 0.33 HP Power Exhaust	15 kW	100	100	110	110	125	125	45	45	50	35	35	45
		30 kW	100	110	110	125	125	150	60	60	70	45	50	50
		45 kW	150	175	150	175	175	175	80	90	90	70	70	70
		60 kW	150	175	175	175	175	200	90	90	90	70	70	80
		90 kW	225	250	225	250	225	300	125	125	150	100	100	110
³ Minimum Circuit Ampacity	Unit+ Electric Heat and (2) 0.33 HP Power Exhaust	15 kW	87	87	93	93	102	102	38	41	45	31	33	37
		30 kW	98	110	106	118	115	127	55	58	63	44	47	50
		45 kW	137	155	145	163	154	172	77	81	85	62	65	68
		60 kW	145	164	152	172	162	181	82	85	90	66	68	72
		90 kW	207	236	215	244	224	253	118	122	126	94	97	101

ELECTRICAL ACCESSORIES

Disconnect	Unit Only	54W86	54W86	54W86	54W86	54W86	54W86	54W86	54W85	54W85	54W85	54W85	54W85	54W85
	Unit + Power Exhaust	54W86	54W86	54W86	54W86	54W86	54W86	54W86	54W85	54W85	54W85	54W85	54W85	54W85
	Unit + Electric Heat 15 kW	54W86	54W86	54W86	54W86	54W86	54W86	54W86	54W85	54W85	54W85	54W85	54W85	54W85
	Unit + Electric Heat 30 kW	54W86	54W86	54W86	54W86	54W86	54W86	54W86	54W85	54W85	54W85	54W85	54W85	54W85
	Unit + Electric Heat 45 kW	54W86	54W86	54W86	54W86	54W87	54W87	54W87	54W85	54W85	54W85	54W85	54W85	54W85
	Unit + Electric Heat 60 kW	54W87	54W87	54W87	54W87	54W87	54W87	54W87	54W86	54W86	54W86	54W85	54W85	54W85
	Unit + Electric Heat 90 kW	⁴ N/A	⁴ N/A	⁴ N/A	⁴ N/A	⁴ N/A	⁴ N/A	⁴ N/A	54W86	54W86	54W86	54W86	54W86	54W86
	Unit + Power Exhaust + Elec. Heat 15 kW	54W86	54W86	54W86	54W86	54W86	54W86	54W86	54W85	54W85	54W85	54W85	54W85	54W85
	Unit + Power Exhaust + Elec. Heat 30 kW	54W86	54W86	54W86	54W86	54W86	54W86	54W86	54W85	54W85	54W85	54W85	54W85	54W85
	Unit + Power Exhaust + Elec. Heat 45 kW	54W86	54W86	54W86	54W86	54W87	54W87	54W87	54W85	54W85	54W85	54W85	54W85	54W85
	Unit + Power Exhaust + Elec. Heat 60 kW	54W87	54W87	54W87	54W87	54W87	54W87	54W87	54W86	54W86	54W86	54W85	54W85	54W85
	Unit + Power Exhaust + Elec. Heat 90 kW	⁴ N/A	⁴ N/A	⁴ N/A	⁴ N/A	⁴ N/A	⁴ N/A	⁴ N/A	54W86	54W86	54W86	54W86	54W86	54W86

NOTE - All units have a minimum Short Circuit Current Rating (SCCR) of 5000 amps.

¹ Extremes of operating range are plus and minus 10% of line voltage.

² HACR type breaker or fuse.

³ Refer to National or Canadian Electrical Code manual to determine wire, fuse and disconnect size requirements.

⁴ Disconnect must be field furnished.

ELECTRICAL/ELECTRIC HEAT DATA

STANDARD EFFICIENCY - 20 TON

KCB240S4

¹ Voltage - 60hz		208/230V - 3 Ph			460V - 3 Ph			575V - 3 Ph		
Compressor 1	Rated Load Amps	22.4			10.6			7.7		
	Locked Rotor Amps	149			75			54		
Compressor 2	Rated Load Amps	22.4			10.6			7.7		
	Locked Rotor Amps	149			75			54		
Compressor 3	Rated Load Amps	25			12.2			9		
	Locked Rotor Amps	164			100			78		
Outdoor Fan Motors (4)	Full Load Amps	2.4			1.3			1		
	(total)	(9.6)			(5.2)			(4)		
Power Exhaust (2) 0.33 HP	Full Load Amps	2.4			1.3			1		
	(total)	(4.8)			(2.6)			(2)		
Service Outlet 115V GFI (amps)		15			15			20		
Indoor Blower Motor	Horsepower	5	7.5	10	5	7.5	10	5	7.5	10
	Full Load Amps	16.7	24.2	30.8	7.6	11	14	6.1	9	11
² Maximum Overcurrent Protection	Unit Only	125	125	125	60	60	70	45	45	50
	With (2) 0.33 HP Power Exhaust	125	125	150	60	60	70	45	50	50
³ Minimum Circuit Ampacity	Unit Only	103	110	118	50	53	57	37	40	43
	With (2) 0.33 HP Power Exhaust	108	115	123	52	56	59	39	42	45

ELECTRIC HEAT DATA

Electric Heat Voltage			208V	240V	208V	240V	208V	240V	480V	480V	480V	600V	600V	600V
² Maximum Overcurrent Protection	Unit+ Electric Heat	15 kW	125	125	125	125	125	125	60	60	70	45	45	50
		30 kW	125	125	125	125	125	150	60	60	70	45	50	50
		45 kW	150	175	150	175	175	175	80	90	90	70	70	70
		60 kW	150	175	175	175	175	200	90	90	90	70	70	80
		90 kW	225	250	225	250	250	300	125	125	150	100	100	110
³ Minimum Circuit Ampacity	Unit+ Electric Heat	15 kW	103	103	110	110	118	118	50	53	57	37	40	43
		30 kW	103	112	110	121	118	129	55	59	63	44	48	50
		45 kW	139	157	148	166	156	174	78	82	86	62	66	68
		60 kW	146	166	156	175	164	183	82	86	90	66	69	72
		90 kW	209	238	218	247	227	256	118	123	126	95	98	101
² Maximum Overcurrent Protection	Unit+ Electric Heat and (2) 0.33 HP Power Exhaust	15 kW	125	125	125	125	150	150	60	60	70	45	50	50
		30 kW	125	125	125	150	150	150	60	70	70	50	50	60
		45 kW	150	175	175	175	175	200	90	90	90	70	70	80
		60 kW	175	175	175	200	175	200	90	90	100	70	80	80
		90 kW	225	250	225	300	250	300	125	150	150	100	110	110
³ Minimum Circuit Ampacity	Unit+ Electric Heat and (2) 0.33 HP Power Exhaust	15 kW	108	108	115	115	123	123	52	56	59	39	42	45
		30 kW	108	118	115	127	123	135	58	63	66	47	50	53
		45 kW	145	163	154	172	162	180	81	85	89	65	68	71
		60 kW	152	172	162	181	170	189	85	90	93	68	72	74
		90 kW	215	244	224	253	233	262	122	126	130	97	101	103

ELECTRICAL ACCESSORIES

Disconnect	Unit Only	54W86	54W86	54W86	54W86	54W86	54W86	54W86	54W85	54W85	54W85	54W85	54W85	54W85
	Unit + Power Exhaust	54W86	54W86	54W86	54W86	54W86	54W86	54W86	54W85	54W85	54W85	54W85	54W85	54W85
	Unit + Electric Heat 15 kW	54W86	54W86	54W86	54W86	54W86	54W86	54W86	54W85	54W85	54W85	54W85	54W85	54W85
	Unit + Electric Heat 30 kW	54W86	54W86	54W86	54W86	54W86	54W86	54W86	54W85	54W85	54W85	54W85	54W85	54W85
	Unit + Electric Heat 45 kW	54W86	54W86	54W87	54W87	54W87	54W87	54W87	54W85	54W85	54W85	54W85	54W85	54W85
	Unit + Electric Heat 60 kW	54W87	54W87	54W87	54W87	54W87	54W87	54W87	54W86	54W86	54W86	54W85	54W85	54W85
	Unit + Electric Heat 90 kW	⁴ N/A	⁴ N/A	⁴ N/A	⁴ N/A	⁴ N/A	⁴ N/A	⁴ N/A	54W86	54W86	54W86	54W86	54W86	54W86
	Unit + Power Exhaust + Elec. Heat 15 kW	54W86	54W86	54W86	54W86	54W86	54W86	54W86	54W85	54W85	54W85	54W85	54W85	54W85
	Unit + Power Exhaust + Elec. Heat 30 kW	54W86	54W86	54W86	54W86	54W86	54W86	54W86	54W85	54W85	54W85	54W85	54W85	54W85
	Unit + Power Exhaust + Elec. Heat 45 kW	54W86	54W86	54W87	54W87	54W87	54W87	54W87	54W85	54W85	54W85	54W85	54W85	54W85
	Unit + Power Exhaust + Elec. Heat 60 kW	54W87	54W87	54W87	54W87	54W87	54W87	54W87	54W86	54W86	54W86	54W85	54W85	54W85
	Unit + Power Exhaust + Elec. Heat 90 kW	⁴ N/A	⁴ N/A	⁴ N/A	⁴ N/A	⁴ N/A	⁴ N/A	⁴ N/A	54W86	54W86	54W86	54W86	54W86	54W86

NOTE - All units have a minimum Short Circuit Current Rating (SCCR) of 5000 amps.

¹ Extremes of operating range are plus and minus 10% of line voltage.

² HACR type breaker or fuse.

³ Refer to National or Canadian Electrical Code manual to determine wire, fuse and disconnect size requirements.

⁴ Disconnect must be field furnished.

ELECTRICAL/ELECTRIC HEAT DATA

STANDARD EFFICIENCY - 25 TON

KCB300S4

¹ Voltage - 60hz		208/230V - 3 Ph			460V - 3 Ph			575V - 3 Ph		
Compressor 1	Rated Load Amps	19.6			8.2			6.6		
	Locked Rotor Amps	136			66.1			55.3		
Compressor 2	Rated Load Amps	19.6			8.2			6.6		
	Locked Rotor Amps	136			66.1			55.3		
Compressor 3	Rated Load Amps	22.4			10.6			7.7		
	Locked Rotor Amps	149			75			54		
Compressor 4	Rated Load Amps	22.4			10.6			7.7		
	Locked Rotor Amps	149			75			54		
Outdoor Fan	Full Load Amps	2.4			1.3			1		
Motors (6)	(total)	(14.4)			(7.8)			(6)		
Power Exhaust	Full Load Amps	2.4			1.3			1		
(2) 0.33 HP	(total)	(4.8)			(2.6)			(2)		
Service Outlet 115V GFI (amps)		15			15			20		
Indoor Blower Motor	Horsepower	5	7.5	10	5	7.5	10	5	7.5	10
	Full Load Amps	16.7	24.2	30.8	7.6	11	14	6.1	9	11
² Maximum Overcurrent Protection	Unit Only	125	150	150	60	70	70	50	50	50
	With (2) 0.33 HP Power Exhaust	150	150	150	60	70	70	50	50	60
³ Minimum Circuit Ampacity	Unit Only	121	129	137	56	60	63	43	46	49
	With (2) 0.33 HP Power Exhaust	126	134	142	59	62	66	45	48	51

ELECTRIC HEAT DATA

Electric Heat Voltage		208V	240V	208V	240V	208V	240V	480V	480V	480V	600V	600V	600V	
² Maximum Overcurrent Protection	Unit+ Electric Heat	15 kW	125	125	150	150	150	150	60	70	70	50	50	50
	and (2) 0.33 HP Power Exhaust	30 kW	125	125	150	150	150	150	60	70	70	50	50	50
		45 kW	150	175	150	175	175	175	80	90	90	70	70	70
		60 kW	150	175	175	175	175	200	90	90	90	70	70	80
		90 kW	225	250	225	250	250	300	125	125	150	100	100	110
³ Minimum Circuit Ampacity	Unit+ Electric Heat	15 kW	121	121	129	129	137	137	56	60	63	43	46	49
	and (2) 0.33 HP Power Exhaust	30 kW	121	121	129	129	137	137	56	60	63	44	48	50
		45 kW	139	157	148	166	156	174	78	82	86	62	66	68
		60 kW	146	166	156	175	164	183	82	86	90	66	69	72
		90 kW	209	238	218	247	227	256	118	123	126	95	98	101
² Maximum Overcurrent Protection	Unit+ Electric Heat	15 kW	150	150	150	150	150	60	70	70	50	50	60	
	and (2) 0.33 HP Power Exhaust	30 kW	150	150	150	150	150	150	60	70	70	50	50	60
		45 kW	150	175	175	175	175	200	90	90	90	70	70	80
		60 kW	175	175	175	200	175	200	90	90	100	70	80	80
		90 kW	225	250	225	300	250	300	125	150	150	100	110	110
³ Minimum Circuit Ampacity	Unit+ Electric Heat	15 kW	126	126	134	134	142	142	59	62	66	45	48	51
	and (2) 0.33 HP Power Exhaust	30 kW	126	126	134	134	142	142	59	63	66	47	50	53
		45 kW	145	163	154	172	162	180	81	85	89	65	68	71
		60 kW	152	172	162	181	170	189	85	90	93	68	72	74
		90 kW	215	244	224	253	233	262	122	126	130	97	101	103

ELECTRICAL ACCESSORIES

Disconnect	Unit Only	54W86	54W86	54W86	54W86	54W86	54W86	54W86	54W85	54W85	54W85	54W85	54W85	54W85
	Unit + Power Exhaust	54W86	54W86	54W86	54W86	54W87	54W87	54W87	54W85	54W85	54W85	54W85	54W85	54W85
	Unit + Electric Heat 15 kW	54W86	54W86	54W86	54W86	54W86	54W86	54W86	54W85	54W85	54W85	54W85	54W85	54W85
	Unit + Electric Heat 30 kW	54W86	54W86	54W86	54W86	54W86	54W86	54W86	54W85	54W85	54W85	54W85	54W85	54W85
	Unit + Electric Heat 45 kW	54W86	54W86	54W87	54W87	54W87	54W87	54W87	54W85	54W85	54W85	54W85	54W85	54W85
	Unit + Electric Heat 60 kW	54W87	54W87	54W87	54W87	54W87	54W87	54W87	54W86	54W86	54W86	54W85	54W85	54W85
	Unit + Electric Heat 90 kW	⁴ N/A	⁴ N/A	⁴ N/A	⁴ N/A	⁴ N/A	⁴ N/A	⁴ N/A	54W86	54W86	54W86	54W86	54W86	54W86
	Unit + Power Exhaust + Elec. Heat 15 kW	54W86	54W86	54W86	54W86	54W87	54W87	54W87	54W85	54W85	54W85	54W85	54W85	54W85
	Unit + Power Exhaust + Elec. Heat 30 kW	54W86	54W86	54W86	54W86	54W87	54W87	54W87	54W85	54W85	54W85	54W85	54W85	54W85
	Unit + Power Exhaust + Elec. Heat 45 kW	54W86	54W86	54W87	54W87	54W87	54W87	54W87	54W85	54W85	54W85	54W85	54W85	54W85
	Unit + Power Exhaust + Elec. Heat 60 kW	54W87	54W87	54W87	54W87	54W87	54W87	54W87	54W86	54W86	54W86	54W85	54W85	54W85
Unit + Power Exhaust + Elec. Heat 90 kW	⁴ N/A	⁴ N/A	⁴ N/A	⁴ N/A	⁴ N/A	⁴ N/A	⁴ N/A	54W86	54W86	54W86	54W86	54W86	54W86	

NOTE - All units have a minimum Short Circuit Current Rating (SCCR) of 5000 amps.

¹ Extremes of operating range are plus and minus 10% of line voltage.

² HACR type breaker or fuse.

³ Refer to National or Canadian Electrical Code manual to determine wire, fuse and disconnect size requirements.

⁴ Disconnect must be field furnished.

ELECTRICAL/ELECTRIC HEAT DATA

HIGH EFFICIENCY - 13 TON

KCA156H4

¹ Voltage - 60hz		208/230V - 3 Ph			460V - 3 Ph			575V - 3 Ph		
Compressor 1	Rated Load Amps	14.5			6.3			6		
	Locked Rotor Amps	98			55			41		
Compressor 2	Rated Load Amps	14.5			6.3			6		
	Locked Rotor Amps	98			55			41		
Compressor 3	Rated Load Amps	14.5			6.3			6		
	Locked Rotor Amps	98			55			41		
Outdoor Fan Motors (3)	Full Load Amps	2.4			1.3			1		
	(total)	(7.2)			(3.9)			(3)		
Power Exhaust (2) 0.33 HP	Full Load Amps	2.4			1.3			1		
	(total)	(4.8)			(2.6)			(2)		
Service Outlet 115V GFI (amps)		15			15			20		
Indoor Blower Motor	Horsepower	2	3	5	2	3	5	2	3	5
	Full Load Amps	7.5	10.6	16.7	3	5	8	3	4	6
² Maximum Overcurrent Protection	Unit Only	70	70	80	30	35	35	30	30	30
	With (2) 0.33 HP Power Exhaust	80	80	90	35	35	40	30	30	35
³ Minimum Circuit Ampacity	Unit Only	62	65	72	28	30	33	26	27	29
	With (2) 0.33 HP Power Exhaust	67	70	77	31	32	35	28	29	31

ELECTRIC HEAT DATA

Electric Heat Voltage			208V	240V	208V	240V	208V	240V	480V	480V	480V	600V	600V	600V
² Maximum Overcurrent Protection	Unit+ Electric Heat	15 kW	70	70	70	70	80	80	30	35	35	30	30	30
		30 kW	⁴ 90	100	⁴ 100	110	⁴ 100	125	50	60	60	40	45	45
		45 kW	150	150	150	150	⁴ 150	175	80	80	80	60	60	70
		60 kW	⁴ 150	175	⁴ 150	175	⁴ 150	175	80	80	90	70	70	70
³ Minimum Circuit Ampacity	Unit+ Electric Heat	15 kW	62	62	65	65	72	72	28	30	33	26	27	29
		30 kW	88	100	92	104	100	112	50	52	55	40	41	44
		45 kW	127	145	131	149	139	157	72	74	78	58	60	62
		60 kW	135	154	139	158	146	166	77	79	82	62	63	66
² Maximum Overcurrent Protection	Unit+ Electric Heat and (2) 0.33 HP Power Exhaust	15 kW	80	80	80	80	90	90	35	35	40	30	30	35
		30 kW	⁴ 100	110	⁴ 100	110	⁴ 110	125	60	60	60	45	45	50
		45 kW	⁴ 150	175	⁴ 150	175	⁴ 150	175	80	80	90	70	70	70
		60 kW	⁴ 150	175	⁴ 150	175	175	175	80	90	90	70	70	70
³ Minimum Circuit Ampacity	Unit+ Electric Heat and (2) 0.33 HP Power Exhaust	15 kW	67	67	70	70	77	77	31	32	36	28	29	31
		30 kW	94	106	98	110	106	118	53	55	58	42	44	47
		45 kW	133	151	137	155	145	163	76	77	81	61	62	65
		60 kW	141	160	145	164	152	172	80	82	85	64	66	68

ELECTRICAL ACCESSORIES

Disconnect	Unit Only	54W85	54W85	54W85	54W85	54W85	54W85	54W85	54W85	54W85	54W85	54W85	54W85	54W85
	Unit + Power Exhaust	54W85	54W85	54W85	54W85	54W86	54W86	54W85	54W85	54W85	54W85	54W85	54W85	54W85
	Unit + Electric Heat 15 kW	54W85	54W85	54W85	54W85	54W85	54W85	54W85	54W85	54W85	54W85	54W85	54W85	54W85
	Unit + Electric Heat 30 kW	54W86	54W86	54W86	54W86	54W86	54W86	54W85	54W85	54W85	54W85	54W85	54W85	54W85
	Unit + Electric Heat 45 kW	54W87	54W86	54W87	54W86	54W87	54W86	54W85	54W85	54W85	54W85	54W85	54W85	54W85
	Unit + Electric Heat 60 kW	54W87	54W87	54W87	54W87	54W87	54W87	54W86	54W86	54W86	54W86	54W85	54W85	54W85
	Unit + Power Exhaust + Elec. Heat 15 kW	54W85	54W85	54W85	54W85	54W85	54W85	54W85	54W85	54W85	54W85	54W85	54W85	54W85
Unit + Power Exhaust + Elec. Heat 30 kW	54W86	54W86	54W86	54W86	54W86	54W86	54W85	54W85	54W85	54W85	54W85	54W85	54W85	
Unit + Power Exhaust + Elec. Heat 45 kW	54W87	54W86	54W87	54W86	54W87	54W86	54W85	54W85	54W85	54W85	54W85	54W85	54W85	
Unit + Power Exhaust + Elec. Heat 60 kW	54W87	54W87	54W87	54W87	54W87	54W87	54W86	54W86	54W86	54W86	54W85	54W85	54W85	

NOTE - All units have a minimum Short Circuit Current Rating (SCCR) of 5000 amps.

¹ Extremes of operating range are plus and minus 10% of line voltage.

² HACR type breaker or fuse.

³ Refer to National or Canadian Electrical Code manual to determine wire, fuse and disconnect size requirements.

ELECTRICAL/ELECTRIC HEAT DATA

HIGH EFFICIENCY - 15 TON

KCA180H4

¹ Voltage - 60hz		208/230V - 3 Ph			460V - 3 Ph			575V - 3 Ph		
Compressor 1	Rated Load Amps	13.2			6.3			4.9		
	Locked Rotor Amps	93			60			41		
Compressor 2	Rated Load Amps	13.2			6.3			4.9		
	Locked Rotor Amps	93			60			41		
Compressor 3	Rated Load Amps	13.2			6.3			4.9		
	Locked Rotor Amps	93			60			41		
Outdoor Fan Motors (4)	Full Load Amps (total)	2.4 (9.6)			1.3 (5.2)			1 (4)		
Power Exhaust (2) 0.33 HP	Full Load Amps (total)	2.4 (4.8)			1.3 (2.6)			1 (2)		
Service Outlet 115V GFI (amps)		15			15			20		
Indoor Blower Motor	Horsepower	3	5	7.5	3	5	7.5	3	5	7.5
	Full Load Amps	10.6	16.7	24.2	4.8	7.6	11	3.9	6.1	9
² Maximum Overcurrent Protection	Unit Only	70	80	100	35	40	45	25	30	35
	With (2) 0.33 HP Power Exhaust	80	90	100	35	40	50	30	30	40
³ Minimum Circuit Ampacity	Unit Only	64	71	80	31	34	38	24	27	30
	With (2) 0.33 HP Power Exhaust	68	75	85	34	37	41	26	29	32

ELECTRIC HEAT DATA

Electric Heat Voltage		208V	240V	208V	240V	208V	240V	480V	480V	480V	600V	600V	600V	
² Maximum Overcurrent Protection	Unit+ Electric Heat	15 kW	70	70	80	80	100	100	35	40	45	25	30	35
		30 kW	100	110	100	125	110	125	60	60	60	45	45	50
		45 kW	150	150	150	175	150	175	80	80	90	60	70	70
		60 kW	150	175	150	175	175	175	80	90	90	70	70	70
³ Minimum Circuit Ampacity	Unit+ Electric Heat	15 kW	64	64	71	71	80	80	31	34	38	24	27	30
		30 kW	92	104	100	112	109	121	52	55	59	41	44	48
		45 kW	131	149	139	157	148	166	74	78	82	60	62	66
		60 kW	139	158	146	166	156	175	79	82	86	63	66	69
² Maximum Overcurrent Protection	Unit+ Electric Heat and (2) 0.33 HP Power Exhaust	15 kW	80	80	90	90	100	100	35	40	50	30	30	40
		30 kW	100	110	110	125	125	150	60	60	70	45	50	50
		45 kW	150	175	150	175	175	175	80	90	90	70	70	70
		60 kW	150	175	175	175	175	200	90	90	90	70	70	80
³ Minimum Circuit Ampacity	Unit+ Electric Heat and (2) 0.33 HP Power Exhaust	15 kW	68	68	75	75	85	85	34	37	41	26	29	32
		30 kW	98	110	106	118	115	127	55	58	63	44	47	50
		45 kW	137	155	145	163	154	172	77	81	85	62	65	68
		60 kW	145	164	152	172	162	181	82	85	90	66	68	72

ELECTRICAL ACCESSORIES

Disconnect	Unit Only	54W85	54W85	54W85	54W85	54W86	54W86	54W85	54W85	54W85	54W85	54W85	54W85
	Unit + Power Exhaust	54W85	54W85	54W86	54W86	54W86	54W86	54W85	54W85	54W85	54W85	54W85	54W85
	Unit + Electric Heat 15 kW	54W85	54W85	54W85	54W85	54W85	54W85	54W85	54W85	54W85	54W85	54W85	54W85
	Unit + Electric Heat 30 kW	54W86	54W86	54W86	54W86	54W86	54W86	54W85	54W85	54W85	54W85	54W85	54W85
	Unit + Electric Heat 45 kW	54W87	54W86	54W87	54W86	54W87	54W87	54W85	54W85	54W85	54W85	54W85	54W85
	Unit + Electric Heat 60 kW	54W87	54W87	54W87	54W87	54W87	54W87	54W86	54W86	54W86	54W85	54W85	54W85
Unit + Power Exhaust + Elec. Heat 15 kW	54W85	54W85	54W85	54W85	54W86	54W85	54W85	54W85	54W85	54W85	54W85	54W85	
Unit + Power Exhaust + Elec. Heat 30 kW	54W86	54W86	54W86	54W86	54W86	54W86	54W85	54W85	54W85	54W85	54W85	54W85	
Unit + Power Exhaust + Elec. Heat 45 kW	54W87	54W86	54W87	54W86	54W87	54W87	54W85	54W85	54W85	54W85	54W85	54W85	
Unit + Power Exhaust + Elec. Heat 60 kW	54W87	54W87	54W87	54W87	54W87	54W87	54W86	54W86	54W86	54W85	54W85	54W85	

NOTE - All units have a minimum Short Circuit Current Rating (SCCR) of 5000 amps.

¹ Extremes of operating range are plus and minus 10% of line voltage.

² HACR type breaker or fuse.

³ Refer to National or Canadian Electrical Code manual to determine wire, fuse and disconnect size requirements.

ELECTRICAL/ELECTRIC HEAT DATA

HIGH EFFICIENCY - 17.5 TON

KCA210H4

¹ Voltage - 60hz		208/230V - 3 Ph			460V - 3 Ph			575V - 3 Ph		
Compressor 1	Rated Load Amps	15.6			7.8			5.8		
	Locked Rotor Amps	110			52			38.9		
Compressor 2	Rated Load Amps	15.6			7.8			5.8		
	Locked Rotor Amps	110			52			38.9		
Compressor 3	Rated Load Amps	19.6			8.2			6.6		
	Locked Rotor Amps	136			66.1			55.3		
Outdoor Fan	Full Load Amps	2.4			1.3			1		
Motors (6)	(total)	(14.4)			(7.8)			(6)		
Power Exhaust	Full Load Amps	2.4			1.3			1		
(2) 0.33 HP	(total)	(4.8)			(2.6)			(2)		
Service Outlet 115V GFI (amps)		15			15			20		
Indoor Blower Motor	Horsepower	3	5	7.5	3	5	7.5	3	5	7.5
	Full Load Amps	10.6	16.7	24.2	5	8	11	3.9	6.1	9
² Maximum Overcurrent Protection	Unit Only	100	100	110	45	45	50	35	35	40
	With (2) 0.33 HP Power Exhaust	100	110	110	45	50	50	35	40	45
³ Minimum Circuit Ampacity	Unit Only	81	87	96	39	42	46	30	32	36
	With (2) 0.33 HP Power Exhaust	86	92	101	42	44	48	32	34	38

ELECTRIC HEAT DATA

Electric Heat Voltage			208V	240V	208V	240V	208V	240V	480V	480V	480V	600V	600V	600V
² Maximum Overcurrent Protection	Unit+ Electric Heat	15 kW	100	100	100	100	110	110	45	45	50	35	35	40
		30 kW	100	110	100	125	110	125	60	60	60	45	45	50
		45 kW	150	150	150	175	150	175	80	80	90	60	70	70
		60 kW	150	175	150	175	175	175	80	90	90	70	70	70
		90 kW	225	250	225	250	225	250	125	125	125	100	100	100
³ Minimum Circuit Ampacity	Unit+ Electric Heat	15 kW	81	81	87	87	96	96	39	42	46	30	32	36
		30 kW	92	104	100	112	109	121	52	55	59	41	44	48
		45 kW	131	149	139	157	148	166	74	78	82	60	62	66
		60 kW	139	158	146	166	156	175	79	82	86	63	66	69
		90 kW	201	230	209	238	218	247	115	118	123	92	95	98
² Maximum Overcurrent Protection	Unit+ Electric Heat and (2) 0.33 HP Power Exhaust	15 kW	100	100	110	110	110	110	45	50	50	35	40	45
		30 kW	100	110	110	125	125	150	60	60	70	45	50	50
		45 kW	150	175	150	175	175	175	80	90	90	70	70	70
		60 kW	150	175	175	175	175	200	90	90	90	70	70	80
		90 kW	225	250	225	250	225	300	125	125	150	100	100	110
³ Minimum Circuit Ampacity	Unit+ Electric Heat and (2) 0.33 HP Power Exhaust	15 kW	86	86	92	92	101	101	42	44	48	32	34	38
		30 kW	98	110	106	118	115	127	55	58	63	44	47	50
		45 kW	137	155	145	163	154	172	77	81	85	62	65	68
		60 kW	145	164	152	172	162	181	82	85	90	66	68	72
		90 kW	207	236	215	244	224	253	118	122	126	94	97	101

ELECTRICAL ACCESSORIES

Disconnect	Unit Only	54W86	54W86	54W86	54W86	54W86	54W86	54W86	54W85	54W85	54W85	54W85	54W85	54W85
	Unit + Power Exhaust	54W86	54W86	54W86	54W86	54W86	54W86	54W86	54W85	54W85	54W85	54W85	54W85	54W85
	Unit + Electric Heat 15 kW	54W86	54W86	54W86	54W86	54W86	54W86	54W86	54W85	54W85	54W85	54W85	54W85	54W85
	Unit + Electric Heat 30 kW	54W86	54W86	54W86	54W86	54W86	54W86	54W86	54W85	54W85	54W85	54W85	54W85	54W85
	Unit + Electric Heat 45 kW	54W86	54W86	54W86	54W86	54W87	54W87	54W87	54W85	54W85	54W85	54W85	54W85	54W85
	Unit + Electric Heat 60 kW	54W87	54W87	54W87	54W87	54W87	54W87	54W87	54W86	54W86	54W86	54W85	54W85	54W85
	Unit + Electric Heat 90 kW	⁴ N/A	⁴ N/A	⁴ N/A	⁴ N/A	⁴ N/A	⁴ N/A	⁴ N/A	54W86	54W86	54W86	54W86	54W86	54W86
	Unit + Power Exhaust + Elec. Heat 15 kW	54W86	54W86	54W86	54W86	54W86	54W86	54W86	54W85	54W85	54W85	54W85	54W85	54W85
	Unit + Power Exhaust + Elec. Heat 30 kW	54W86	54W86	54W86	54W86	54W86	54W86	54W86	54W85	54W85	54W85	54W85	54W85	54W85
	Unit + Power Exhaust + Elec. Heat 45 kW	54W86	54W86	54W86	54W86	54W87	54W87	54W87	54W85	54W85	54W85	54W85	54W85	54W85
Unit + Power Exhaust + Elec. Heat 60 kW	54W87	54W87	54W87	54W87	54W87	54W87	54W87	54W86	54W86	54W86	54W85	54W85	54W85	
Unit + Power Exhaust + Elec. Heat 90 kW	⁴ N/A	⁴ N/A	⁴ N/A	⁴ N/A	⁴ N/A	⁴ N/A	⁴ N/A	54W86	54W86	54W86	54W86	54W86	54W86	

NOTE - All units have a minimum Short Circuit Current Rating (SCCR) of 5000 amps.

¹ Extremes of operating range are plus and minus 10% of line voltage.

² HACR type breaker or fuse.

³ Refer to National or Canadian Electrical Code manual to determine wire, fuse and disconnect size requirements.

⁴ Disconnect must be field furnished.

ELECTRICAL/ELECTRIC HEAT DATA

HIGH EFFICIENCY - 20 TON

KCA240H4

¹ Voltage - 60hz		208/230V - 3 Ph			460V - 3 Ph			575V - 3 Ph		
Compressor 1	Rated Load Amps	13.2			6.3			4.9		
	Locked Rotor Amps	93			60			41		
Compressor 2	Rated Load Amps	13.2			6.3			4.9		
	Locked Rotor Amps	93			60			41		
Compressor 3	Rated Load Amps	13.2			6.3			4.9		
	Locked Rotor Amps	93			60			41		
Compressor 4	Rated Load Amps	13.2			6.3			4.9		
	Locked Rotor Amps	93			60			41		
Outdoor Fan Motors (6)	Full Load Amps	2.4			1.3			1		
	(total)	(14.4)			(7.8)			(6)		
Power Exhaust (2) 0.33 HP	Full Load Amps	2.4			1.3			1		
	(total)	(4.8)			(2.6)			(2)		
Service Outlet 115V GFI (amps)		15			15			20		
Indoor Blower Motor	Horsepower	5	7.5	10	5	7.5	10	5	7.5	10
	Full Load Amps	16.7	24.2	30.8	7.6	11	14	6.1	9	11
² Maximum Overcurrent Protection	Unit Only	100	110	125	50	50	60	35	45	50
	With (2) 0.33 HP Power Exhaust	100	125	125	50	60	60	40	45	50
³ Minimum Circuit Ampacity	Unit Only	89	98	106	43	47	51	34	37	40
	With (2) 0.33 HP Power Exhaust	93	103	111	46	50	54	36	39	42

ELECTRIC HEAT DATA

		Electric Heat Voltage	208V	240V	208V	240V	208V	240V	480V	480V	480V	600V	600V	600V
² Maximum Overcurrent Protection	Unit+	15 kW	100	100	110	110	125	125	50	50	60	35	45	50
	Electric Heat	30 kW	100	125	110	125	125	150	60	60	70	45	50	50
		45 kW	150	175	150	175	175	175	80	90	90	70	70	70
		60 kW	150	175	175	175	175	200	90	90	90	70	70	80
		90 kW	225	250	225	250	250	300	125	125	150	100	100	110
³ Minimum Circuit Ampacity	Unit+	15 kW	89	89	98	98	106	106	43	47	51	34	37	40
	Electric Heat	30 kW	100	112	109	121	117	129	55	59	63	44	48	50
		45 kW	139	157	148	166	156	174	78	82	86	62	66	68
		60 kW	146	166	156	175	164	183	82	86	90	66	69	72
		90 kW	209	238	218	247	227	256	118	123	126	95	98	101
² Maximum Overcurrent Protection	Unit+	15 kW	100	100	125	125	125	125	50	60	60	40	45	50
	Electric Heat and (2) 0.33 HP Power Exhaust	30 kW	110	125	125	150	125	150	60	70	70	50	50	60
		45 kW	150	175	175	175	175	200	90	90	90	70	70	80
		60 kW	175	175	175	200	175	200	90	90	100	70	80	80
		90 kW	225	250	225	300	250	300	125	150	150	100	110	110
³ Minimum Circuit Ampacity	Unit+	15 kW	93	93	103	103	111	111	46	50	54	36	39	42
	Electric Heat and (2) 0.33 HP Power Exhaust	30 kW	106	118	115	127	123	135	58	63	66	47	50	53
		45 kW	145	163	154	172	162	180	81	85	89	65	68	71
		60 kW	152	172	162	181	170	189	85	90	93	68	72	74
		90 kW	215	244	224	253	233	262	122	126	130	97	101	103

ELECTRICAL ACCESSORIES

Disconnect	Unit Only	54W86	54W86	54W86	54W86	54W86	54W86	54W86	54W85	54W85	54W85	54W85	54W85	54W85
	Unit + Power Exhaust	54W86	54W86	54W86	54W86	54W86	54W86	54W86	54W85	54W85	54W85	54W85	54W85	54W85
	Unit + Electric Heat 15 kW	54W85	54W85	54W85	54W85	54W86	54W85	54W85	54W85	54W85	54W85	54W85	54W85	54W85
	Unit + Electric Heat 30 kW	54W86	54W86	54W86	54W86	54W86	54W86	54W85	54W85	54W85	54W85	54W85	54W85	54W85
	Unit + Electric Heat 45 kW	54W87	54W86	54W87	54W87	54W87	54W87	54W85	54W85	54W85	54W85	54W85	54W85	54W85
	Unit + Electric Heat 60 kW	54W87	54W87	54W87	54W87	54W87	54W87	54W86	54W86	54W86	54W86	54W85	54W85	54W85
	Unit + Electric Heat 90 kW	⁴ N/A	⁴ N/A	⁴ N/A	⁴ N/A	⁴ N/A	⁴ N/A	54W86	54W86	54W86	54W86	54W86	54W86	54W86
	Unit + Power Exhaust + Elec. Heat 15 kW	54W85	54W85	54W86	54W86	54W86	54W86	54W85	54W85	54W85	54W85	54W85	54W85	54W85
	Unit + Power Exhaust + Elec. Heat 30 kW	54W86	54W86	54W86	54W86	54W86	54W86	54W85	54W85	54W85	54W85	54W85	54W85	54W85
	Unit + Power Exhaust + Elec. Heat 45 kW	54W87	54W86	54W87	54W87	54W87	54W87	54W85	54W85	54W86	54W85	54W85	54W85	54W85
	Unit + Power Exhaust + Elec. Heat 60 kW	54W87	54W87	54W87	54W87	54W87	54W87	54W86	54W86	54W86	54W86	54W85	54W85	54W86
Unit + Power Exhaust + Elec. Heat 90 kW	⁴ N/A	⁴ N/A	⁴ N/A	⁴ N/A	⁴ N/A	⁴ N/A	54W86	54W86	54W86	54W86	54W86	54W86	54W86	

NOTE - All units have a minimum Short Circuit Current Rating (SCCR) of 5000 amps.

¹ Extremes of operating range are plus and minus 10% of line voltage.

² HACR type breaker or fuse.

³ Refer to National or Canadian Electrical Code manual to determine wire, fuse and disconnect size requirements.

⁴ Disconnect must be field furnished.

ELECTRIC HEAT CAPACITIES

Volts Input	15 kW			30 kW			45 kW			60 kW			90 kW		
	kW Input	Btuh Output	No. of Stages	kW Input	Btuh Output	No. of Stages	kW Input	Btuh Output	No. of Stages	kW Input	Btuh Output	No. of Stages	kW Input	Btuh Output	No. of Stages
208	11.3	38,600	1	22.5	76,800	1	33.8	115,300	2	45.0	153,600	2	67.6	230,700	2
220	12.6	43,000	1	25.2	86,000	1	37.8	129,000	2	50.4	172,000	2	75.6	258,000	2
230	13.8	47,100	1	27.5	93,900	1	41.3	141,000	2	55.1	188,000	2	82.7	282,200	2
240	15.0	51,200	1	30.0	102,400	1	45.0	153,600	2	60.0	204,800	2	90.0	307,100	2
440	12.6	43,000	1	25.2	86,000	1	37.8	129,000	2	50.4	172,000	2	75.6	258,000	2
460	13.8	47,100	1	27.5	93,900	1	41.3	141,000	2	55.1	188,000	2	82.7	282,200	2
480	15.0	51,200	1	30.0	102,400	1	45.0	153,600	2	60.0	204,800	2	90.0	307,100	2
550	12.6	43,000	1	25.2	86,000	1	37.8	129,000	2	50.4	172,000	2	75.6	258,000	2
575	13.8	47,100	1	27.5	93,900	1	41.3	141,000	2	55.1	188,000	2	82.7	282,200	2
600	15.0	51,200	1	30.0	102,400	1	45.0	153,600	2	60.0	204,800	2	90.0	307,100	2

UNIT CLEARANCES

Unit With Economizer

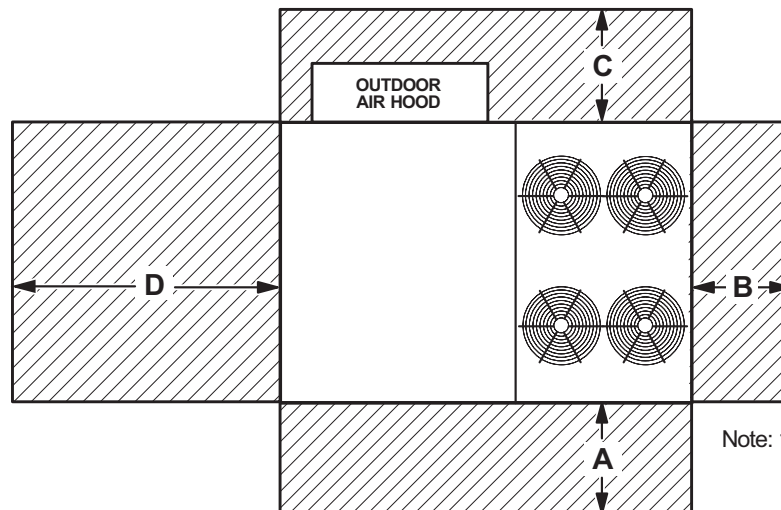

Note: 180H, 240S, 300S sizes shown

¹ Unit Clearance	A		B		C		D		Top Clearance
	in.	mm	in.	mm	in.	mm	in.	mm	
Service Clearance	60	1524	36	914	36	914	66	1676	Unobstructed
Minimum Operation Clearance	45	1143	36	914	36	914	41	1041	

NOTE - Entire perimeter of unit base requires support when elevated above the mounting surface.

¹ Service Clearance - Required for removal of serviceable parts.

Minimum Operation Clearance - Required clearance for proper unit operation.

OUTDOOR SOUND DATA

Unit Model Number	Octave Band Sound Power Levels dBA, re 10 ⁻¹² Watts - Center Frequency - Hz							¹ Sound Rating Number (dBA)
	125	250	500	1000	2000	4000	8000	
156H, 180S, 210S	71	78	81	81	76	71	63	86
180H, 240S	80	83	87	88	84	80	71	93
210H, 240H, 300S	79	84	88	89	85	82	73	94

Note - The octave sound power data does not include tonal corrections.

¹ Sound Rating Number according to AHRI Standard 270-95 (includes pure tone penalty). Sound Rating Number is the overall A-Weighted Sound Power Level, (LWA), dBA (100 Hz to 10,000 Hz).

WEIGHT DATA

Model Number	Outdoor Coil	Net		Shipping		Outdoor Coil	Net		Shipping	
		lbs.	kg	lbs.	kg		lbs.	kg	lbs.	kg
156H Base Unit	Environ™	1785	810	1985	900	---	---	---	---	---
156H Max. Unit	Environ™	2065	937	2265	1027	---	---	---	---	---
180H Base Unit	Environ™	1965	891	2165	982	---	---	---	---	---
180H Max. Unit	Environ™	2245	1018	2445	1109	---	---	---	---	---
210H Base Unit	Environ™	2090	948	2290	1039	---	---	---	---	---
210H Max. Unit	Environ™	2380	1080	2580	1170	---	---	---	---	---
240H Base Unit	Environ™	2175	987	2375	1077	---	---	---	---	---
240H Max. Unit	Environ™	2465	1118	2665	1209	---	---	---	---	---
180S Base Unit	Environ™	1705	773	1905	864	Fin/Tube	1770	802	1970	894
180S Max. Unit	Environ™	2025	919	2225	1009	Fin/Tube	2090	948	2290	1039
210S Base Unit	Environ™	1815	823	2015	914	Fin/Tube	1880	852	2080	944
210S Max. Unit	Environ™	2145	973	2345	1064	Fin/Tube	2210	1002	2410	1094
240S Base Unit	Environ™	2030	921	2230	1012	Fin/Tube	2120	962	2320	1053
240S Max. Unit	Environ™	2360	1070	2560	1161	Fin/Tube	2450	1110	2650	1202
300S Base Unit	Environ™	2300	1043	2500	1134	Fin/Tube	2365	1073	2565	1163
300S Max. Unit	Environ™	2590	1175	2790	1266	Fin/Tube	2655	1204	2855	1295

NOTE - Max. Unit is the unit with ALL INTERNAL OPTIONS Installed. (Economizer, Standard Static Power Exhaust Fans, Controls, etc.). Does not include accessories EXTERNAL to unit.

OPTIONS / ACCESSORIES

Description	Shipping Weight		
	lbs.	kg	
ECONOMIZER / OUTDOOR AIR / EXHAUST			
Economizer			
Economizer Dampers	102	46	
Barometric Relief Dampers (downflow)	30	14	
Barometric Relief Dampers (horizontal)	20	9	
Outdoor Air Damper Hood (downflow)	65	29	
Outdoor Air Dampers			
Outdoor Air Damper Section (downflow) - Automatic (including Hood)	18	39	
Outdoor Air Damper Section (downflow) - Manual (including Hood)	10	22	
Power Exhaust	62	28	
ELECTRIC HEAT			
15 kW	59	27	
30 kW	59	27	
45 kW	76	34	
60 kW	76	34	
90 kW	84	38	
HUMIDITROL® DEHUMIDIFICATION SYSTEM			
Humiditrol® Dehumidification Option (Net Weight)	50	23	
MSAV® (MULTI-STAGE AIR VOLUME) SUPPLY AIR BLOWER OPTION			
Variable Frequency Drive (VFD) and associated components	10	5	
ROOF CURBS			
Hybrid Roof Curbs, Downflow			
8 in. height	75	34	
14 in. height	105	48	
18 in. height	125	57	
24 in. height	155	70	
Adjustable Pitch Curb, Downflow			
14 in. height	262	119	
Horizontal Roof Curbs, Standard			
26 in. height	470	213	
37 in. height	505	229	
30 in. height	575	261	
41 in. height	610	277	
CEILING DIFFUSERS			
Step-Down	RTD11-185S	168	76
	RTD11-275S	238	108
Flush	FD11-185S	168	76
	FD11-275S	238	108
Transitions	C1DIFF33C-1	80	36
	C1DIFF34C-1	75	34
PACKAGING			
LTL Packaging (less than truck load)	310	141	

DIMENSIONS - UNIT

KCA156H | KCB180S | KCB210S

Model No.	CORNER WEIGHTS								CENTER OF GRAVITY			
	AA		BB		CC		DD		EE		FF	
	lbs.	kg	lbs.	kg	lbs.	kg	lbs.	kg	in.	mm	in.	mm
KCA156H Base Unit (Environ™ Coil)	428	195	346	157	456	207	554	252	48 1/2	1232	39 1/2	1003
KCA156H Max. Unit (Environ™ Coil)	538	244	429	195	489	222	609	277	48	1219	43	1086
KCB180S Base Unit (Environ™ Coil)	389	176	335	152	455	206	528	239	50	1270	39	991
KCB180S Max. Unit (Environ™ Coil)	504	229	411	186	499	226	612	278	48	1219	41	1041
KCB180S Base Unit (Fin/Tube Coil)	392	176	365	166	485	219	531	240	50 1/4	1276	39 3/4	1010
KCB180S Max. Unit (Fin/Tube Coil)	506	230	441	199	529	239	614	278	49 1/2	1257	42 3/4	1086
KCB210S Base Unit (Environ™ Coil)	427	194	358	162	470	213	561	254	49	1245	39	991
KCB210S Max. Unit (Environ™ Coil)	549	249	435	197	514	233	648	294	48	1219	42	1067
KCB210S Base Unit (Fin/Tube Coil)	430	194	388	176	500	226	564	255	50 1/4	1276	39 3/4	1010
KCB210S Max. Unit (Fin/Tube Coil)	551	250	465	210	544	246	650	294	49 1/2	1257	42 3/4	1086

Base Unit - The unit with NO INTERNAL OPTIONS.

Max. Unit - The unit with ALL INTERNAL OPTIONS Installed. (Economizer, Standard Static Power Exhaust Fans, Controls, etc.). Does not include accessories external to unit.

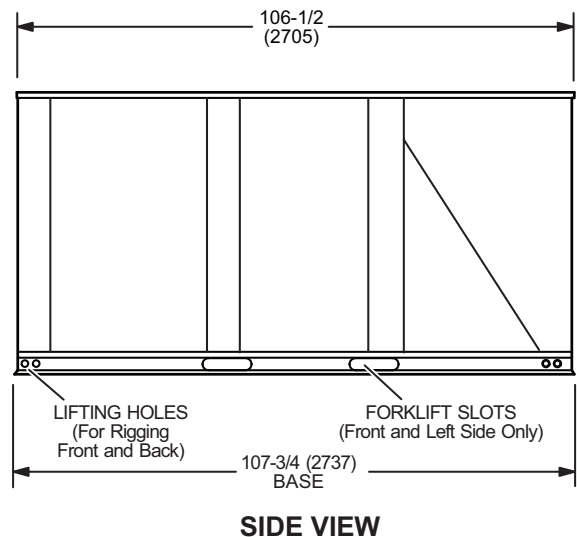
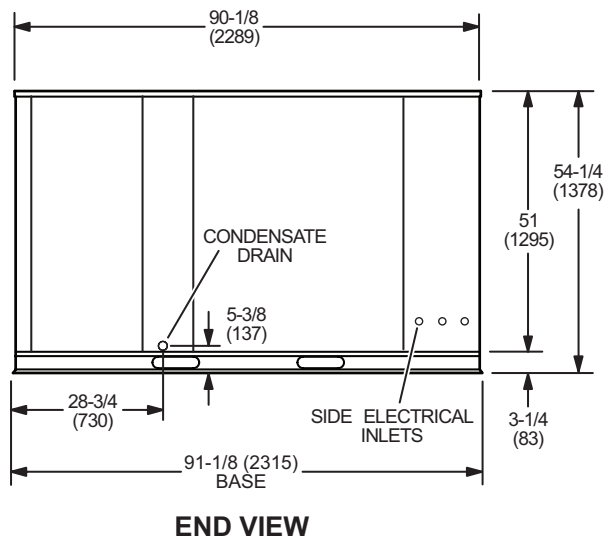
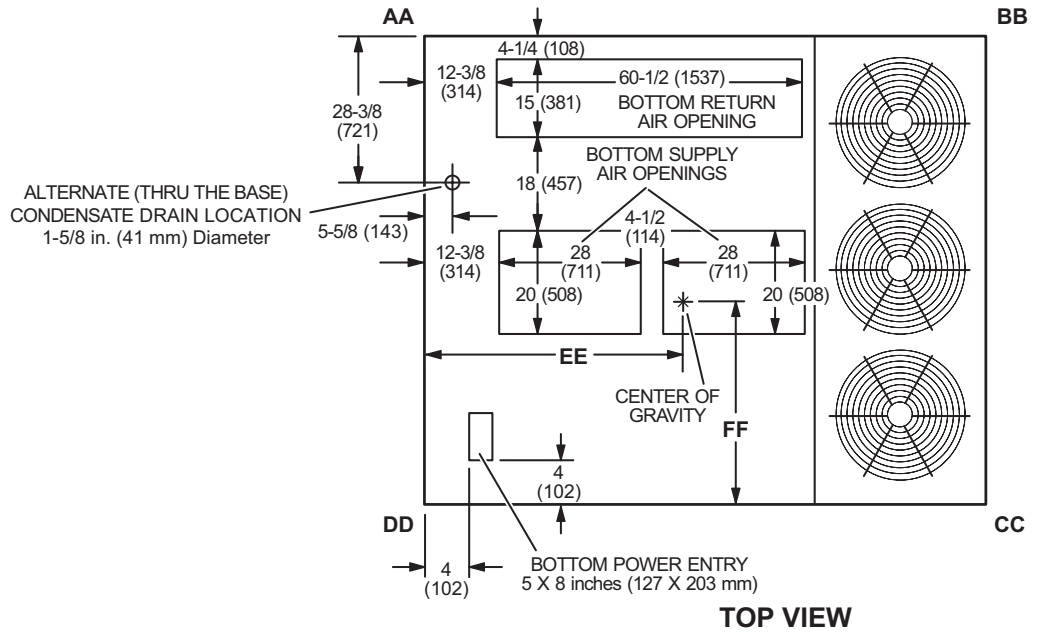

DIMENSIONS - UNIT

KCA180H | KCB240S

CORNER WEIGHTS

CENTER OF GRAVITY

Model No.	AA		BB		CC		DD		EE		FF	
	lbs.	kg	lbs.	kg	lbs.	kg	lbs.	kg	in.	mm	in.	mm
KCA180H Base Unit (Environ™ Coil)	441	201	403	183	543	247	577	262	52	1321	39 1/4	997
KCA180H Max. Unit (Environ™ Coil)	545	248	485	221	577	262	638	290	51	1295	42	1067
KCB240S Base Unit (Environ™ Coil)	432	196	392	178	573	260	632	287	51	1295	37	940
KCB240S Max. Unit (Environ™ Coil)	540	245	476	216	629	285	714	324	50 1/2	1283	39	991
KCB240S Base Unit (Fin/Tube Coil)	432	195	445	202	626	283	632	287	54 3/4	1391	39 1/2	1003
KCB240S Max. Unit (Fin/Tube Coil)	540	244	529	239	681	308	714	323	53 1/2	1359	42	1067

Base Unit - The unit with NO INTERNAL OPTIONS.

Max. Unit - The unit with ALL INTERNAL OPTIONS Installed. (Economizer, Standard Static Power Exhaust Fans, Controls, etc.). Does not include accessories external to unit.

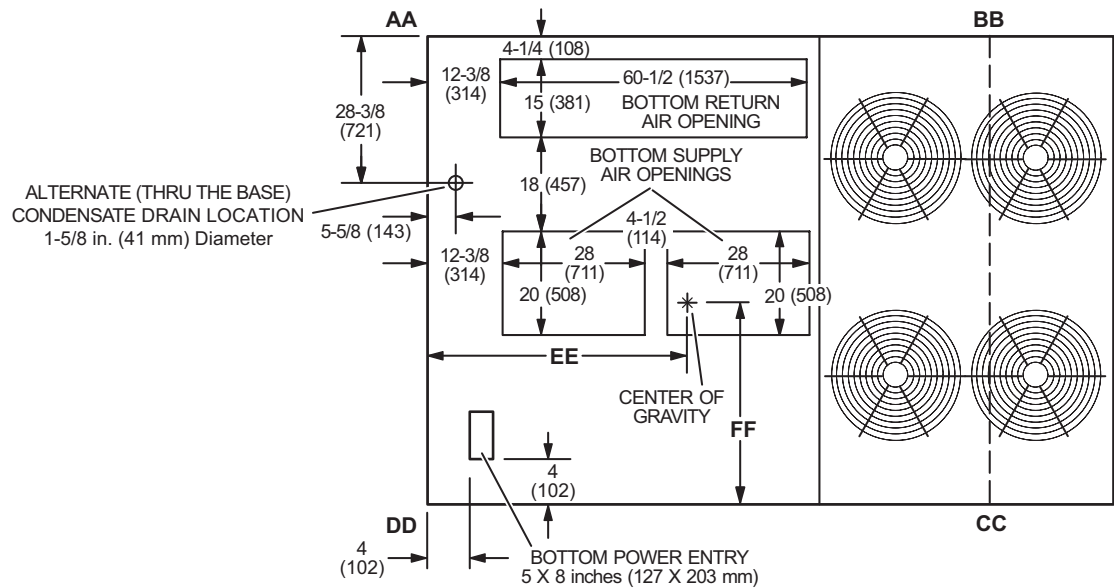

TOP VIEW

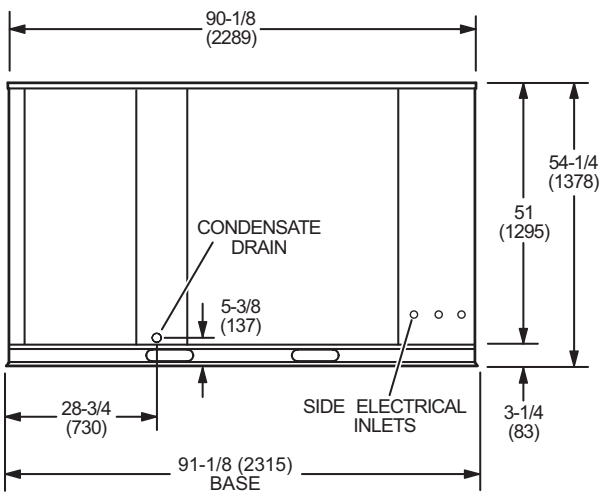

END VIEW

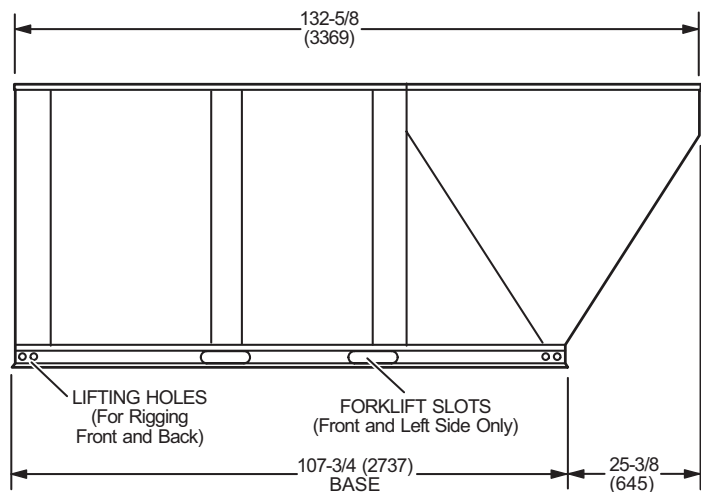

SIDE VIEW

DIMENSIONS - UNIT

KCA210H | KCB240H | KCB300S

CORNER WEIGHTS

CENTER OF GRAVITY

Model No.	AA		BB		CC		DD		EE		FF	
	lbs.	kg	lbs.	kg	lbs.	kg	lbs.	kg	in.	mm	in.	mm
KCA210H Base Unit (Environ™ Coil)	452	205	448	204	600	273	590	268	54	1372	39 1/4	997
KCA210H Max. Unit (Environ™ Coil)	557	253	536	244	635	288	652	296	53	1346	42	1067
KCA240H Base Unit (Environ™ Coil)	462	210	461	210	634	288	617	281	54 1/2	1384	38 3/4	984
KCA240H Max. Unit (Environ™ Coil)	568	258	550	250	668	304	679	308	53 1/2	1359	41 1/2	1054
KCB300S Base Unit (Environ™ Coil)	466	211	487	221	689	313	660	299	55	1397	37 1/2	953
KCB300S Max. Unit (Environ™ Coil)	574	260	578	262	723	328	718	326	54	1372	40 1/2	1029
KCB300S Base Unit (Fin/Tube Coil)	469	212	518	235	724	329	656	297	56 1/2	1435	38	965
KCB300S Max. Unit (Fin/Tube Coil)	575	260	606	274	758	343	719	327	55 1/4	1403	40 1/2	1029

Base Unit - The unit with NO INTERNAL OPTIONS.

Max. Unit - The unit with ALL INTERNAL OPTIONS Installed. (Economizer, Standard Static Power Exhaust Fans, Controls, etc.). Does not include accessories external to unit.

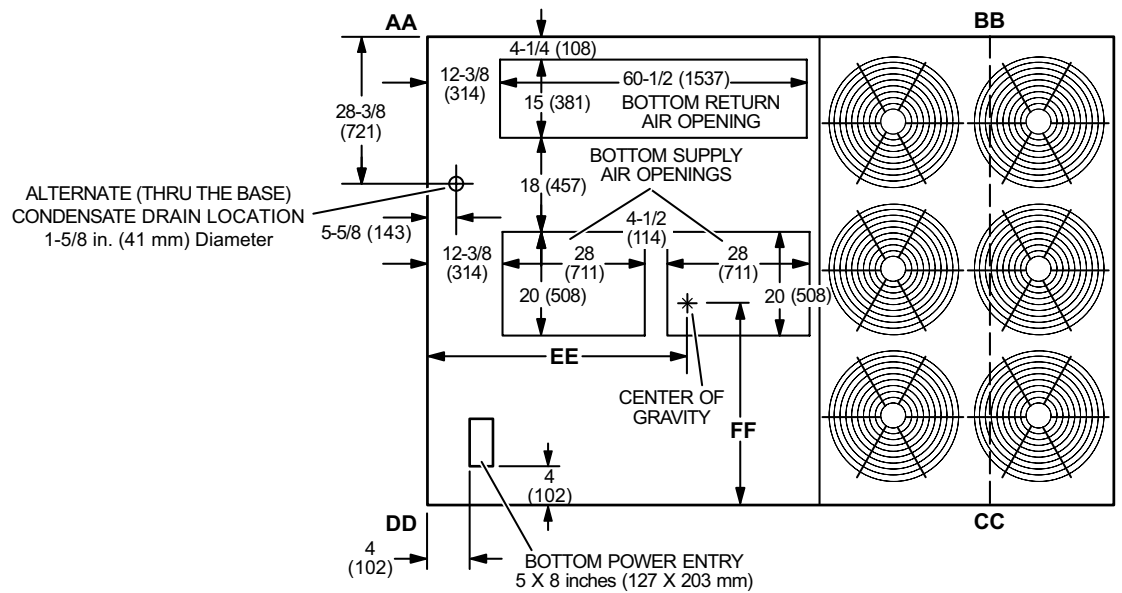

TOP VIEW

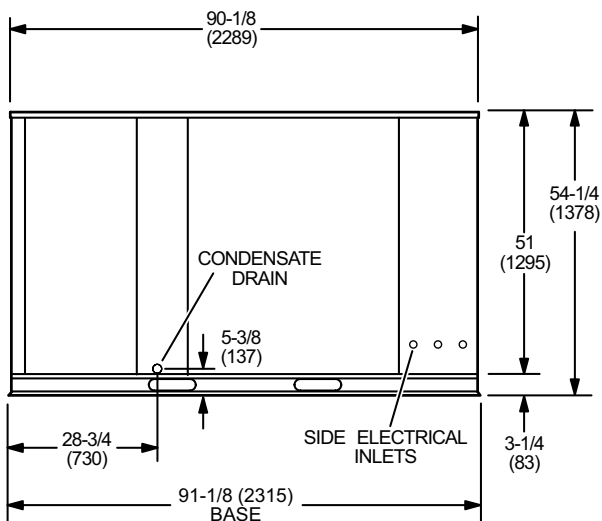

END VIEW

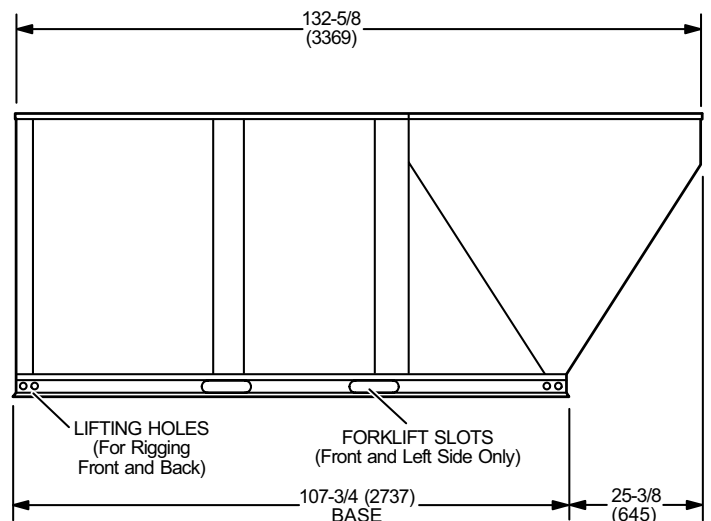

SIDE VIEW

OUTDOOR AIR HOOD DETAIL

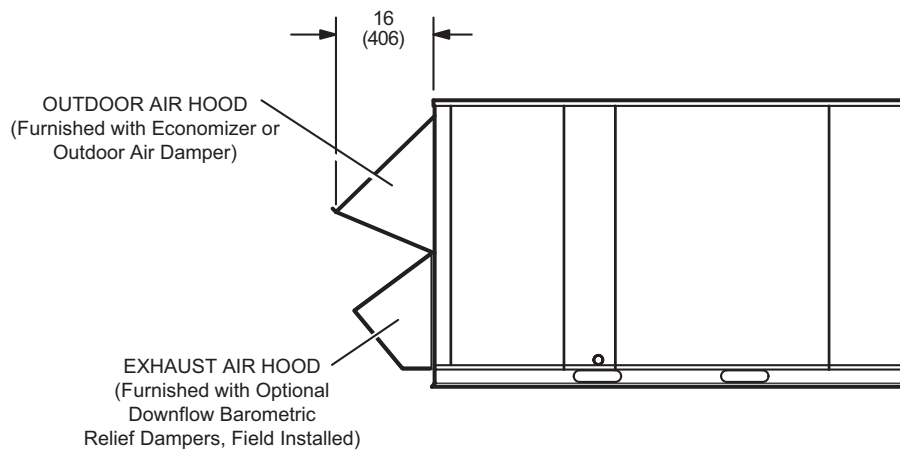

OPTIONAL HORIZONTAL BAROMETRIC RELIEF DAMPERS WITH HOOD

(Field installed in horizontal return air duct adjacent to unit)

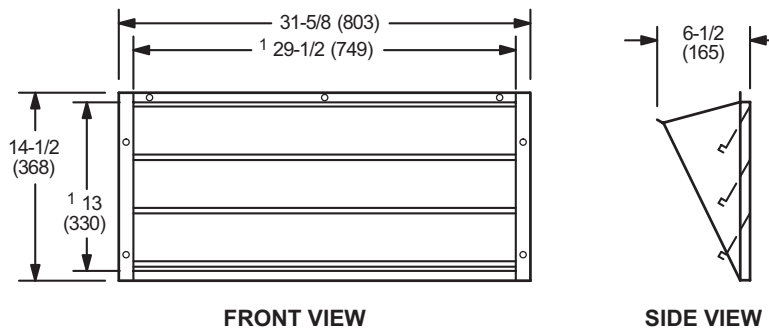

NOTE - Two furnished per order no.
¹ NOTE - Opening size required in return air duct.

DIMENSIONS - ACCESSORIES

HYBRID ROOF CURBS - DOUBLE DUCT OPENING

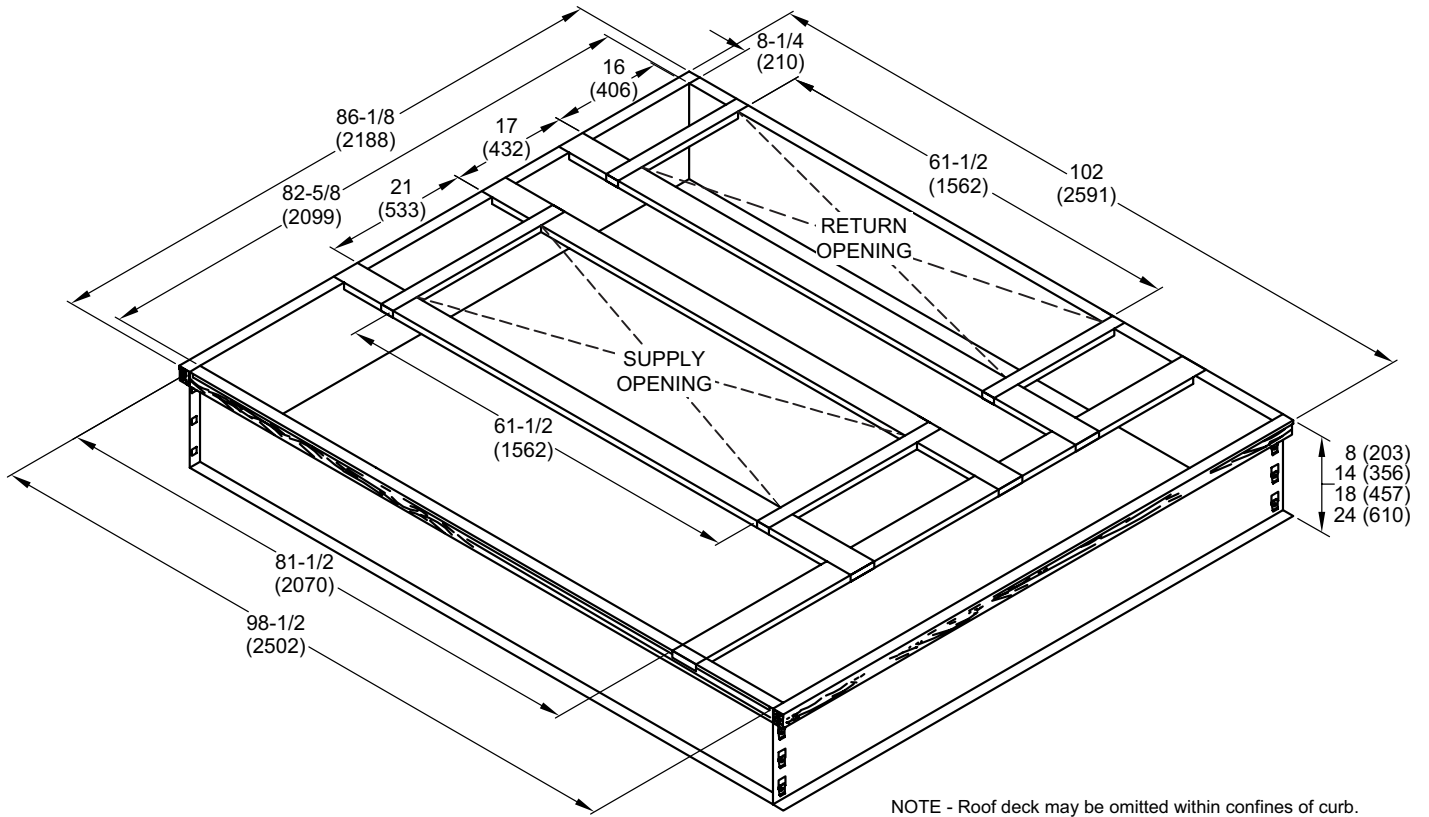

TYPICAL FLASHING DETAIL FOR ROOF CURB

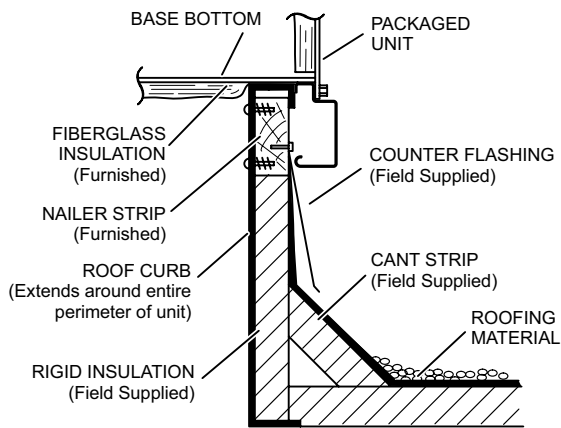

DETAIL ROOF CURB

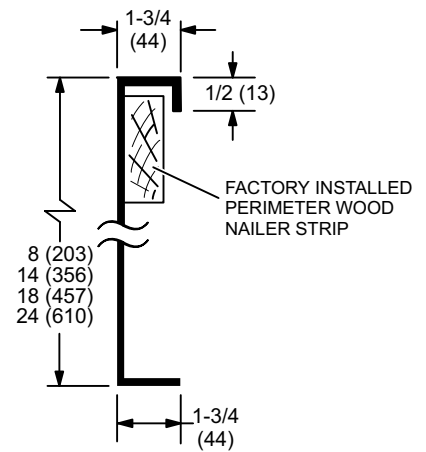

DIMENSIONS - ACCESSORIES

ADJUSTABLE PITCH CURB - DOUBLE DUCT OPENING

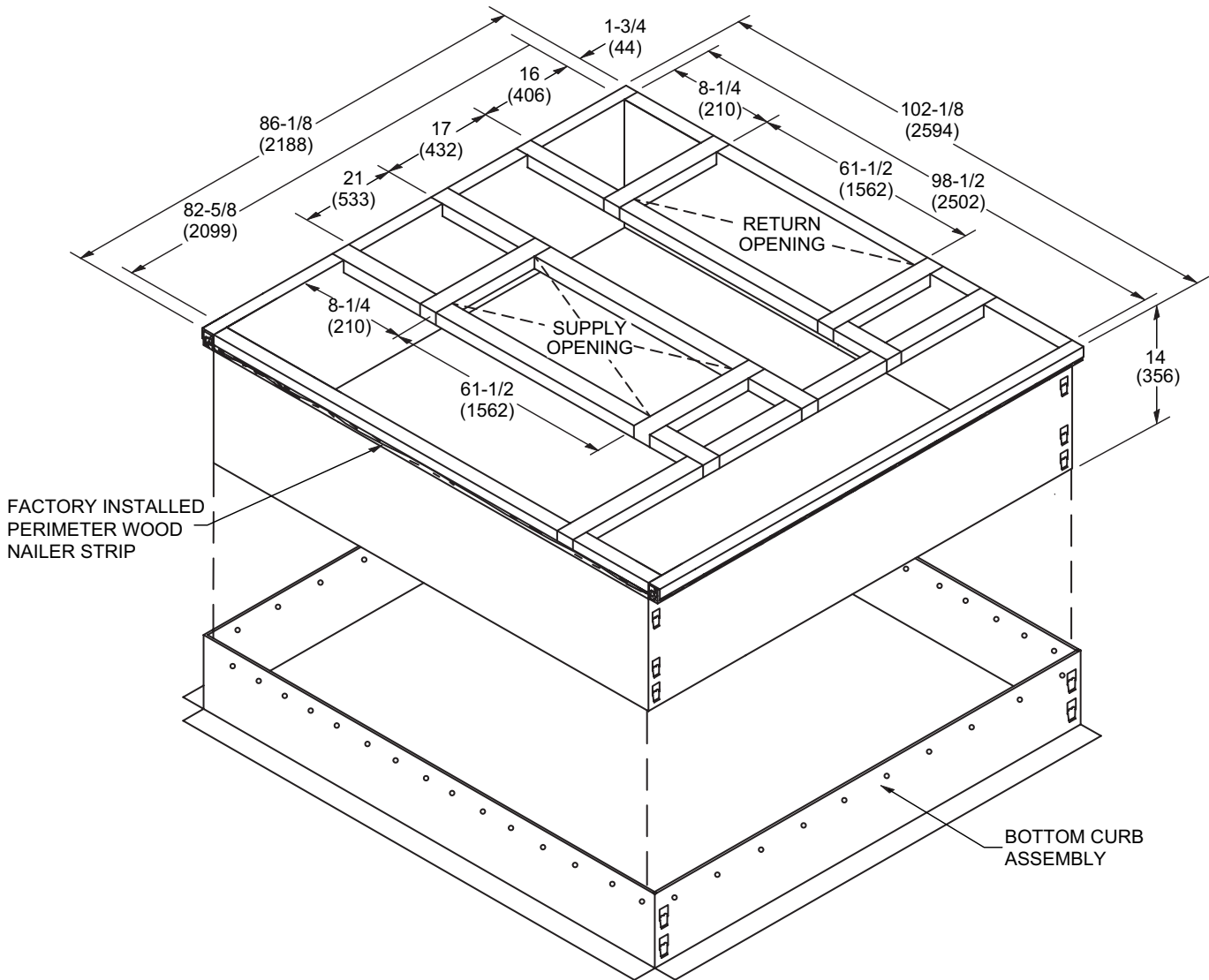

NOTE - Maximum slope pitch is 3/4 in. per 1 foot (19 mm per 305 mm) in any one direction.

TYPICAL FLASHING DETAIL FOR ROOF CURB

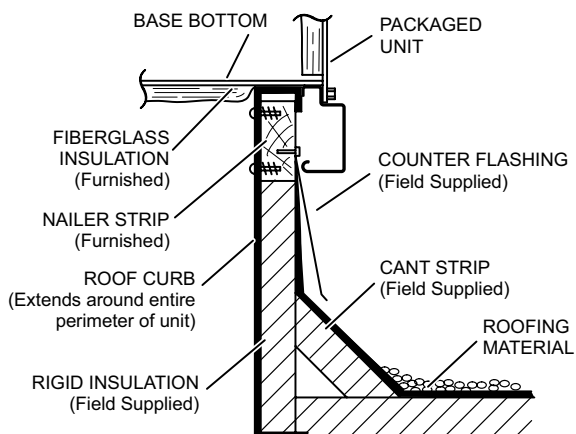

DETAIL ROOF CURB

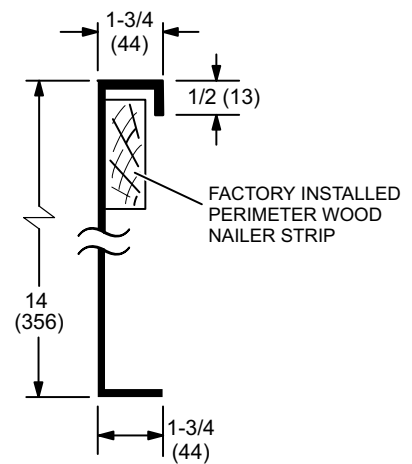

DIMENSIONS - ACCESSORIES

ROOF CURBS WITH SUPPLY & RETURN AIR TRANSITIONS FOR CEILING DIFFUSERS

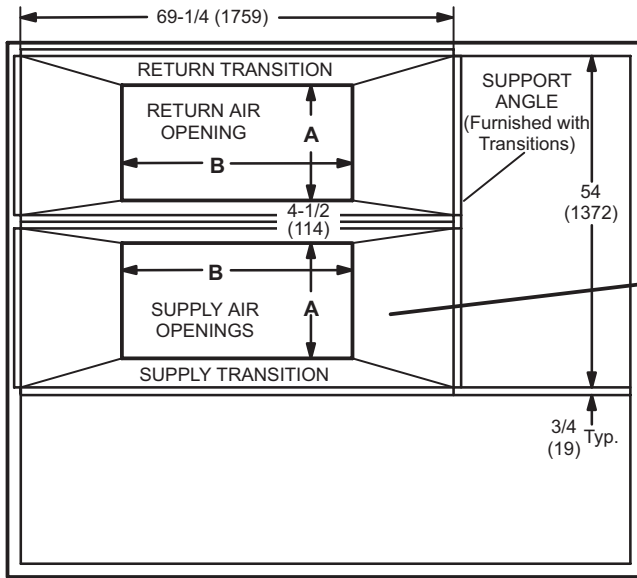

TOP VIEW

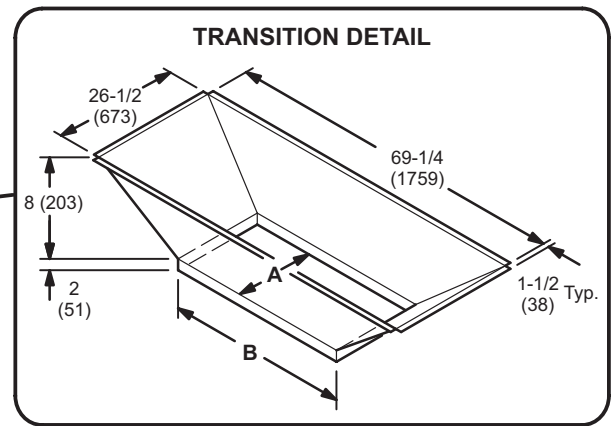

TRANSITION OPENING SIZES

Model Number	A		B	
	inch	mm	inch	mm
C1DIFF33C-1	18	457	36	914
C1DIFF34C-1	24	610	48	1219

DIMENSIONS - ACCESSORIES

HORIZONTAL ROOF CURBS – Requires Optional Horizontal Return Air Panel Kit

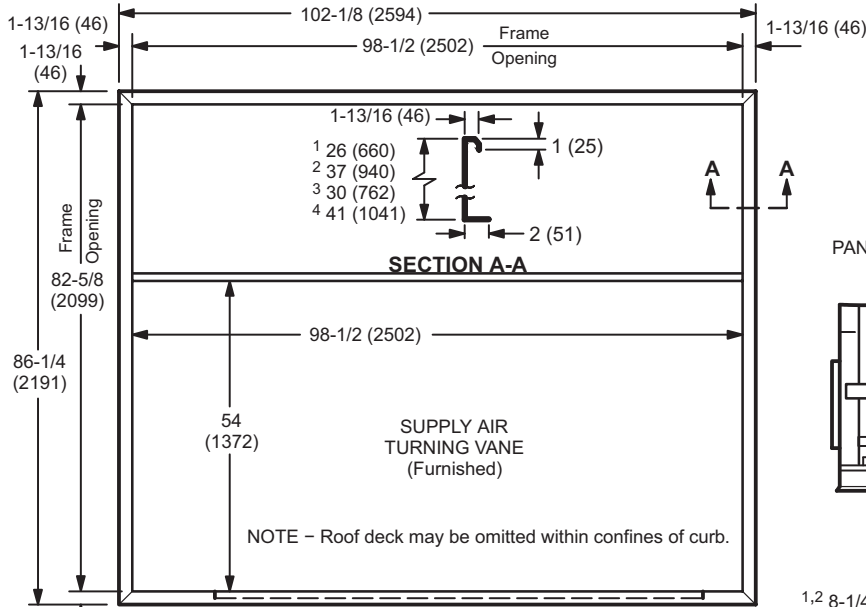

NOTE C1CURB14C-1 and C1CURB15C-1 are designed for horizontal discharge when unit is mounted on a slab. C1CURB16C-1 and C1CURB17C-1 are designed for horizontal discharge when unit is mounted on a rooftop.

PANEL TO COVER RETURN AIR OPENING IN BOTTOM OF UNIT (Furnished With Optional Horizontal Return Air Panel Kit)

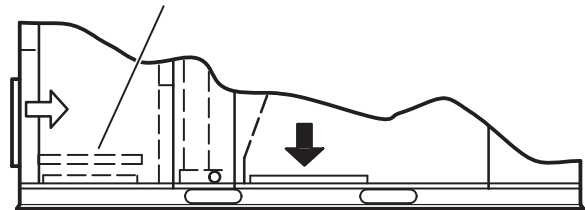

SIDE VIEW (Packaged Unit)

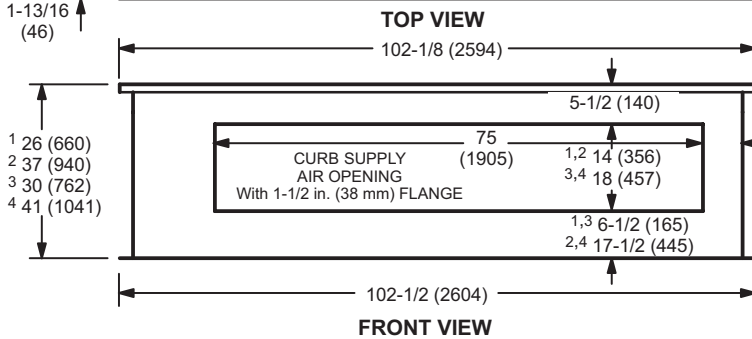

1,2 8-1/4 (210)
3,4 13-1/4 (337)

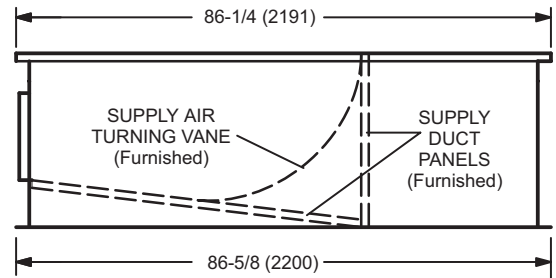

SIDE VIEW

- 1 C1CURB14C-1
- 2 C1CURB16C-1
- 3 C1CURB15C-1 (used with 300)
- 4 C1CURB17C-1 (used with 300)

HORIZONTAL SUPPLY AND RETURN AIR OPENINGS WITH HORIZONTAL ROOF CURB

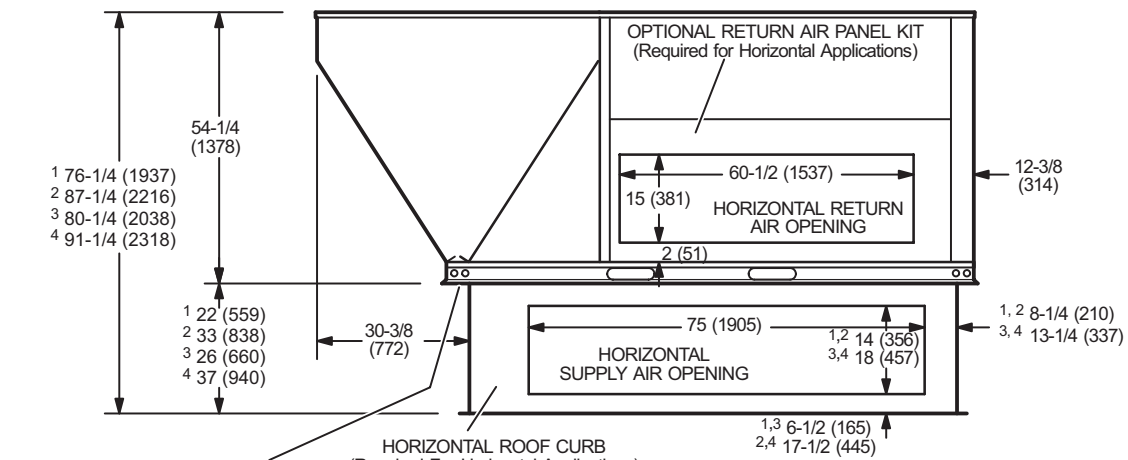

- 1 C1CURB14C-1
- 2 C1CURB16C-1
- 3 C1CURB15C-1 (used with 300 Models Only)
- 4 C1CURB17C-1 (used with 300 Models Only)

DIMENSIONS - ACCESSORIES

COMBINATION CEILING SUPPLY AND RETURN DIFFUSERS

STEP-DOWN CEILING DIFFUSER

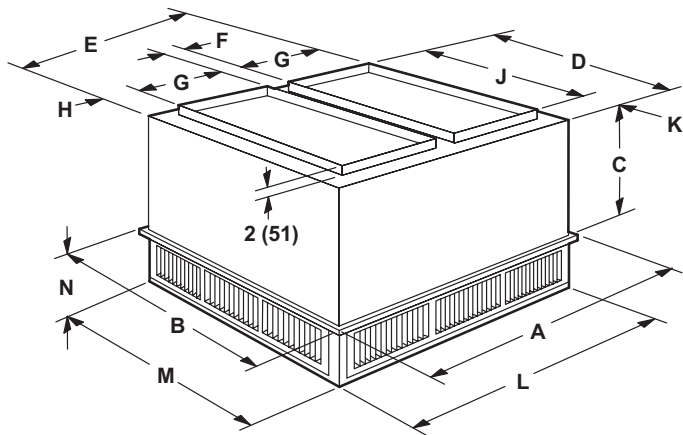

FLUSH CEILING DIFFUSER

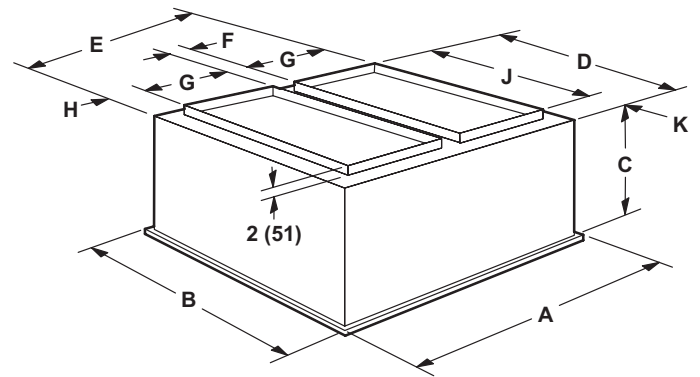

Model Number		RTD11-185S	RTD11-275S
A	in.	47-5/8	59-5/8
	mm	1210	1514
B	in.	47-5/8	59-5/8
	mm	1210	1514
C	in.	24-5/8	30-5/8
	mm	625	778
D	in.	45-1/2	57-1/2
	mm	1156	1461
E	in.	45-1/2	57-1/2
	mm	1156	1461
F	in.	4-1/2	4-1/2
	mm	114	114
G	in.	18	24
	mm	457	610
H	in.	2-1/2	2-1/2
	mm	64	64
J	in.	36	48
	mm	914	1219
K	in.	4-3/4	4-3/4
	mm	121	121
L	in.	45-1/2	57-1/2
	mm	1156	1461
M	in.	45-1/2	57-1/2
	mm	1156	1461
N	in.	10-1/8	11-1/8
	mm	257	283
Duct Size	in.	18 x 36	24 x 48
	mm	457 x 914	610 x 1219

Model Number		FD11-185S	FD11-275S
A	in.	47-5/8	59-5/8
	mm	1210	1514
B	in.	47-5/8	59-5/8
	mm	1210	1514
C	in.	29-1/4	35-1/4
	mm	743	895
D	in.	45	57
	mm	1143	1148
E	in.	45	57
	mm	1143	1448
F	in.	4-1/2	4-1/2
	mm	114	114
G	in.	18	24
	mm	457	610
H	in.	2-1/4	2-1/4
	mm	57	57
J	in.	36	48
	mm	914	1219
K	in.	4-1/2	4-1/2
	mm	114	114
Duct Size	in.	18 x 36	24 x 48
	mm	457 x 914	610 x 1219

REVISIONS

Section	Description
Electrical/Electric Heat Data	Updated for 156H4, 180S4, 180H4, 240H4 models.
Specifications	Ratings updated for 156H4 models.



Visit us at www.lennox.com

For the latest technical information, www.lennoxcommercial.com

Contact us at 1-800-4-LENNOX

NOTE - Due to Lennox' ongoing commitment to quality, Specifications, Ratings and Dimensions subject to change without notice and without incurring liability. Improper installation, adjustment, alteration, service or maintenance can cause property damage or personal injury. Installation and service must be performed by a qualified installer and servicing agency.

©2019 Lennox Industries, Inc.