



**COMMERCIAL  
PRODUCT SPECIFICATIONS**

Bulletin No. 210780  
March 2021  
Supersedes August 2019



**LANDMARK®**  
Performance Marked by Flexibility™



**ASHRAE 90.1  
COMPLIANT**

**2 to 5 Tons**  
**Net Cooling Capacity – 23,600 to 58,000 Btuh**  
**Net Heating Capacity – 24,000 to 59,000 Btuh**  
**Gas Input Heat Capacity – 65,000 to 150,000 Btuh**

**MODEL NUMBER IDENTIFICATION**

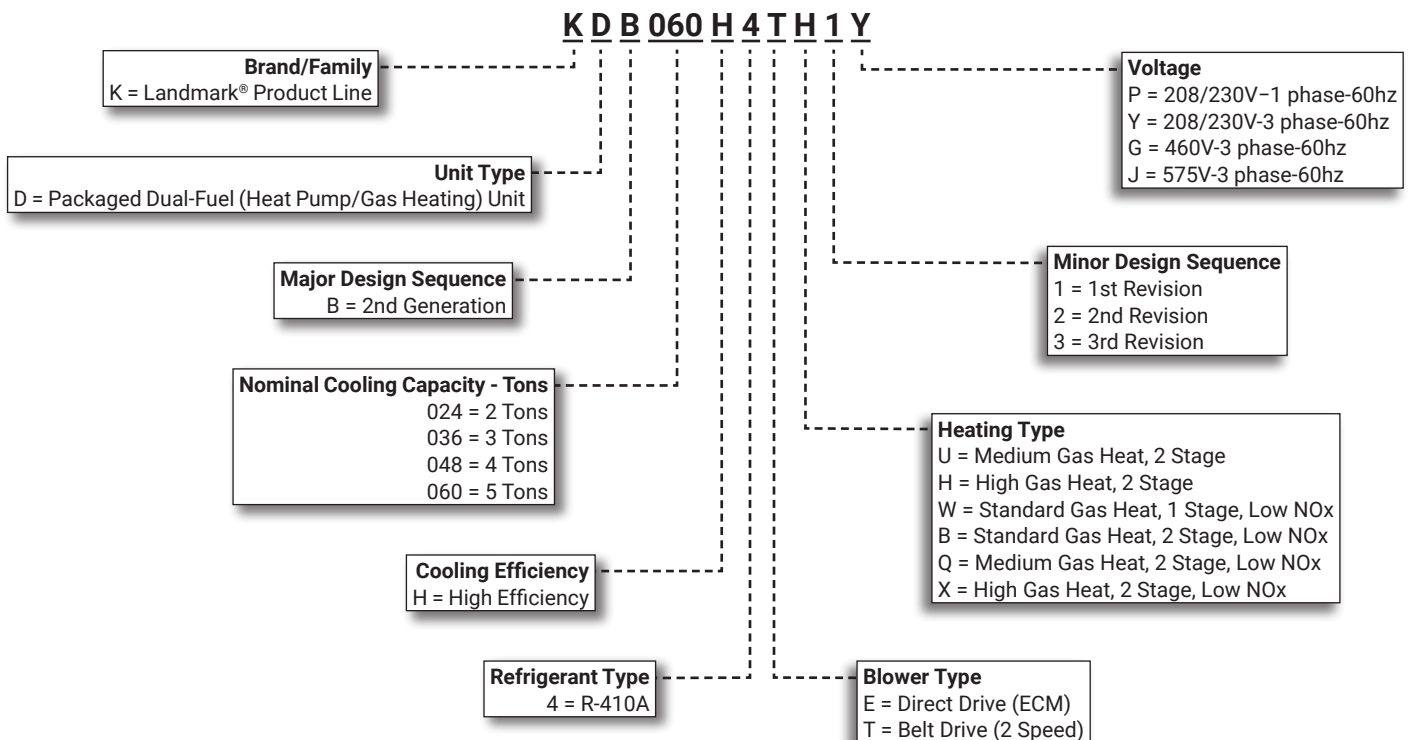

## FEATURE HIGHLIGHTS

Landmark® rooftop units from Lennox are the new standard for reliable, efficient rooftop units built for long-lasting performance that can significantly improve indoor environments.

1. Two-Stage Scroll Compressors
2. Check/Thermal Expansion Valves
3. Reversing Valve
4. Copper Tube Coil
5. Outdoor Coil ECM Fan Motor
6. Heat Exchanger/Inshot Burners
7. Electronic Ignition
8. Heavy Gauge Steel Cabinet
9. Power/Gas Entry
10. Fully Insulated
11. Hinged Access Panels (option)
12. Direct or Belt Drive Blowers
13. Unit Control
14. Air Filters
15. Economizer (option)
16. Barometric Relief Dampers (option)

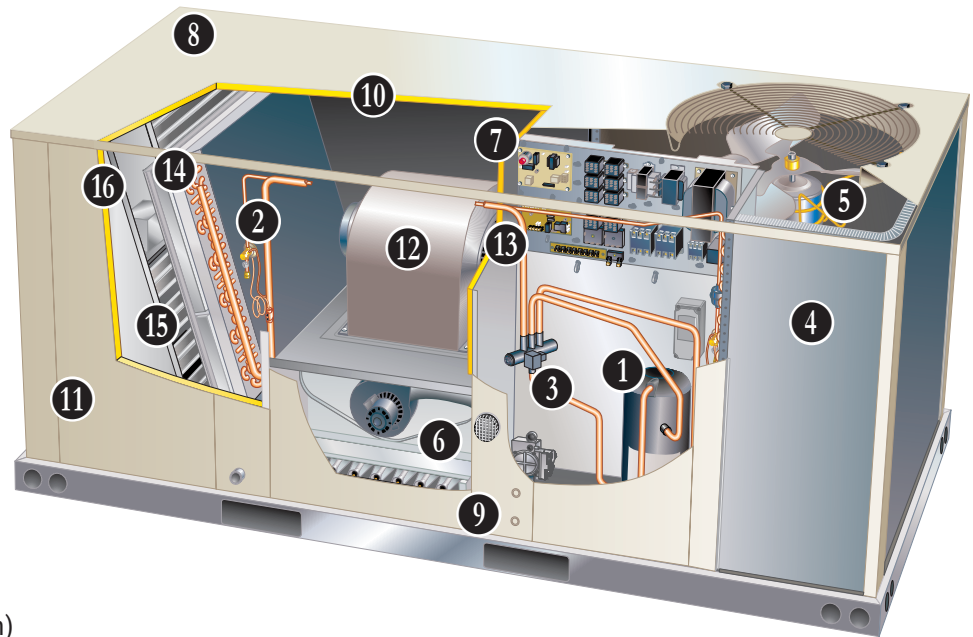

## CONTENTS

Approvals And Warranty . . . . .	3
Blower Data . . . . .	22
Cooling / Heating Ratings . . . . .	18
Dimensions - Accessories . . . . .	39
Dimensions - Unit . . . . .	38
Electrical Data . . . . .	33
Features And Benefits . . . . .	3
High Altitude Derate . . . . .	17
Model Number Identification . . . . .	1
Optional Conventional Temperature Control Systems . . . . .	11
Options / Accessories . . . . .	12
Outdoor Sound Data . . . . .	36
Specifications . . . . .	15
Specifications - Gas Heat . . . . .	17
Specifications - Low Nox Gas Heat . . . . .	17
Unit Clearances . . . . .	36
Weight Data . . . . .	37

## APPROVALS AND WARRANTY

### **APPROVALS**

- AHRI Standard 210/240 certified
- ETL and CSA listed
- CSA certified energy ratings
- Unit and components ETL, NEC and CEC bonded for grounding to meet safety standards for servicing
- All models are ASHRAE 90.1 compliant
- ISO 9001 Registered Manufacturing Quality System

**NOTE** - All single phase models and models equipped with low NOx gas heat option meet the California Nitrogen Oxides Standard (NOx) limits of 40 ng/J that apply in the South Coast Air Quality Management District and the San Francisco Bay Area Air Quality Management District.

### **California Only**

- If installed in South Coast Air Quality Management District (SCAQMD) only:
  - This gas unit does not meet the SCAQMD Rule 1111 NOx emission limit (14 ng/J), and thus is subject to a mitigation fee of up to \$450. This furnace is not eligible for the Clean Air Furnace Rebate Program: [www.CleanAirFurnaceRebate.com](http://www.CleanAirFurnaceRebate.com)
- If installed in San Joaquin Valley Air Pollution Control District (SJVAPCD) only
  - This gas unit does not meet the SJVAPCD Rule 4905 NOx emission limit (14 ng/J), and thus is subject to a mitigation fee of up to \$450

### **WARRANTY**

- Aluminized steel heat exchanger - Limited ten years
- Compressors - Limited five years
- Optional High Performance Economizers - Limited five years
- All other covered components - Limited one year

## FEATURES AND BENEFITS

### **DUAL-FUEL OPERATION**

- In heating mode the unit operates the heat pump for 1st stage heating
- If 1st stage is not satisfied, the 2nd stage will activate gas heating (secondary heat source)
- Heat pump operation is automatically terminated on gas heat start-up
- Unit control automatically changes between heat pump heating and gas heat operation
- Blower starts up when gas heat exchanger is warm, and runs in high speed during (gas heat) operation
- If continuous blower operation is available on thermostat, change in blower speed automatically occurs during heat pump heat to gas heat changeover

### **COOLING / HEATING SYSTEM**

- Designed to maximize sensible and latent cooling performance at design conditions
- System can operate from 30°F to 125°F without any additional controls

### **R-410A Refrigerant**

- Non-chlorine based
- Ozone-friendly

### **1 Two-Stage Scroll Compressor**

- Two-stage scroll compressors for increased part load efficiency, high performance, reliability and quiet operation
- Resiliently mounted on rubber grommets for quiet operation

### **Compressor Crankcase Heater**

- Protects against refrigerant migration that can occur during low ambient operation

### **High Pressure Switch**

- Protects the system from high pressure conditions

### **2 Check/Thermal Expansion Valves**

- Assures optimal performance throughout the application range.
- Removable element head

### **3 Reversing Valve**

- 4-way interchange reversing valve effects a rapid change in direction of refrigerant flow resulting in quick changeover from cooling to heating and vice versa

## FEATURES AND BENEFITS

### COOLING / HEATING SYSTEM (continued)

#### Defrost Control

- Control furnished as standard
- Gives a demand defrost cycle whenever system heating performance falls below optimum levels
- Sensing element on coil determines when defrost cycle is required and when to terminate cycle
- Anti-short cycle (5 minutes) incorporated into the board
- Diagnostic LED's furnished as an aid in troubleshooting

**NOTE** - Gas heating operates during a defrost cycle.

#### Filter/Drier

- High capacity filter/drier protects the system from dirt and moisture

#### Freezestat

- Protects the evaporator coil from damaging ice build-up due to conditions such as low/no air flow, or low refrigerant charge

#### 4 Coil Construction

- Copper tube construction
- Enhanced rippled-edge aluminum fins
- Flared shoulder tubing connections
- Silver soldered construction
- Factory leak tested

#### Indoor Coil

- Cross row circuiting
- Rifled copper tubing optimizes both sensible and latent cooling capacity

#### Condensate Drain Pan

- Plastic pan, sloped to meet drainage requirements of ASHRAE 62.1
- Side or bottom drain connections
- Reversible to allow connection at back of unit

#### 5 Outdoor Coil ECM Fan Motor

- All models have a variable speed (ECM) fan motor for energy efficient and quiet operation
- Standard efficiency models have a single speed PSC fan motor
- Thermal overload protected
- Totally enclosed
- Permanently lubricated sleeve bearing (standard efficiency)
- Permanently lubricated ball bearings (high efficiency)
- Shaft up
- Wire basket mount

#### Outdoor Coil Fan

- PVC coated fan guard furnished

### Required Selections

#### Cooling Capacity

- Specify nominal cooling capacity

### Options/Accessories

#### Field Installed

##### Condensate Drain Trap

- Available in copper or PVC

##### Drain Pan Overflow Switch

- Monitors condensate level in drain pan, shuts down unit if drain becomes clogged

##### Low Ambient Kit (0°F)

- Cycles the outdoor fan while allowing compressor operation in the cooling cycle
- Includes field installed pressure switch on the liquid line to determine when to operate the outdoor fan
- This intermittent fan operation allows the system to operate without icing the evaporator coil and losing capacity
- Designed for use in ambient temperatures no lower than 0°F
- If the liquid line pressure drops below 240 psig outdoor fan operates at 25% normal fan speed
- If pressure drops below 180 psig outdoor fan stops until pressure rises to 300 psig, then fan operates at 25% normal fan speed unless main pressure switch has reset to 450 psig to resume normal cooling operation and full fan speed operation

## FEATURES AND BENEFITS

### **GAS HEATING SYSTEM**

- Aluminized steel inshot burners
- Direct spark ignition
- Electronic flame sensor
- Combustion air inducer
- Redundant automatic single or dual stage gas valve with manual shut-off

### **6 Heat Exchanger**

- Tubular construction
- Aluminized steel
- Life cycle tested

**NOTE** - Stainless Steel Heat Exchanger is required if mixed air temperature is below 45°F.

### **7 Electronic Pilot Ignition**

- Electronic spark igniter provides positive direct ignition of burners on each operating cycle
- System permits main gas valve to stay open only when the burners are proven to be lit
- Should a loss of flame occur, the gas valve closes, shutting off the gas to the burners
- Ignition module has LED to indicate status and aid in troubleshooting
- Watchguard circuit on module automatically resets ignition controls after one hour of continuous thermostat demand after unit lockout, eliminating nuisance service calls
- Ignition control is factory installed in the controls section

### **Limit Controls**

- Factory installed
- Redundant limit controls with fixed temperature setting
- Protect heat exchanger and other components from overheating

### **Safety Switches**

- Flame roll-out switch
- Flame sensor and combustion air inducer proving switch protect system operation

### **Low NOx Models**

- All single phase models are available in low NOx versions (40 ng/J)

### **Required Selections**

#### **Gas Input Choice - Order one:**

- Standard Gas Heat (1 Stage) 65,000 Btuh, Low NOx
- Standard Gas Heat (2 Stage) 53,000/70,000 Btuh, Low NOx
- Medium Gas Heat (2 Stage) 81,000/108,000 Btuh, Standard Gas or Low NOx
- High Gas Heat (2 Stage) 113,000/150,000 Btuh, Standard Gas or Low NOx

#### **Standard or Low NOx Gas Heat**

- Specify standard gas heat or Low NOx (40 ng/J) option (three phase models only)

**NOTE** - All single phase models are Low NOx (40 ng/J) equipped.

### **Options/Accessories**

#### **Field Installed**

##### **Combustion Air Intake Extensions**

- Recommended for use with existing flue extension kits in areas where high snow areas can block intake air

##### **Low Temperature Vestibule Heater**

- Electric heater automatically controls minimum temperature in gas burner compartment when temperature is below -40°F
- C.S.A. Certified to allow operation of unit down to -60°F

##### **LPG/Propane Kits**

- Conversion kit to field change over units from Natural Gas to LPG/Propane

##### **Vertical Vent Extension Kit**

- Use to exhaust flue gases vertically above unit
- Required when unit vent is too close to fresh air intakes per building codes
- Also prevents ice formation on intake louvers

## FEATURES AND BENEFITS

### **CABINET**

#### **8 Construction**

- Heavy-gauge steel panels
- Two-layer enamel paint finish
- Full perimeter heavy-gauge galvanized steel base rail
- Base rails have rigging holes
- Three sides of the base rail have forklift slots
- Raised edges around duct and power entry openings in the bottom of the unit for water protection

#### **Airflow Choice**

- Units are shipped in downflow (vertical) return air configuration
- Can be field converted to horizontal air flow configuration without the need of a kit

#### **9 Power/Gas Entry**

- Electrical and gas lines can be brought through the unit base or through horizontal access knock-outs

**NOTE** - Optional Bottom Gas Entry Kit is available.

#### **10 Insulation**

- Fully insulated with non-hygroscopic fiberglass insulation (conditioned areas)
- Unit base is fully insulated
- Base insulation serves as an air seal to the roof curb, eliminating the need to add a seal during installation

#### **Access Panels**

- Economizer/Filter section
- Heating/Blower section
- Compressor/Controls section

**NOTE** - All 048/060 models include a filler panel for proper cabinet fit for optional accessories (Economizers, Power Exhaust, Outdoor Air Dampers and Barometric Relief Dampers).

### **Options/Accessories**

#### **Factory Installed**

##### **Corrosion Protection**

- Completely flexible immersed coating
- Electrodeposited dry film process
- AST ElectroFin E-Coat
- Meets Mil Spec MIL-P-53084, ASTM B117 Standard Method Salt Spray Testing
- Indoor Corrosion Protection:
  - Coated coil
  - Painted blower housing
  - Painted base
- Outdoor Corrosion Protection:
  - Coated coil
  - Painted outdoor base

#### **11 Hinged Access Panels**

- Economizer/Filter section
- Heating/Blower section
- Compressor/Controls section
- Panel seals and quarter-turn latching handles provide a tight air and water seal

#### **Field Installed**

##### **Combination Coil/Hail Guards**

- Heavy gauge steel frame
- Painted to match cabinet
- Expanded metal mesh protects outdoor coil

#### **BLOWER**

- A wide selection of supply air blower options are available to meet a variety of air flow requirements

##### **Motor**

- Overload protected
- Ball bearings (ECM and belt drive)
- Sleeve bearings (PSC direct drive)

##### **ECM Direct Drive Motor**

- Multi-tap ECM direct drive motors are offered on 024, 030, 036, 048 and 060 models
- Motor has five speed taps to allow adjustment to meet cooling, heating, and ventilation needs at specified external static pressures

##### **Two-Speed Belt Drive Motor**

- Two-speed belt drive motors (low static/high static) are available on 036, 048 and 060 models in several different sizes to maximize air performance

#### **12 Supply Air Blower**

- Forward curved blades
- Blower wheel statically and dynamically balanced
- Belt drive motors have adjustable pulley for speed change

### **Required Selections**

#### **Supply Air Blower**

- Order direct drive or belt drive blower (See Blower Data Table for specifications)
- Belt Drive - Order drive kit, see Drive Kit Specifications Table

## FEATURES AND BENEFITS

### CONTROLS

#### **13** Unit Control

- All control voltage is provided via a 24V (secondary) transformer with built-in circuit breaker protection
- Up to 2 heat / 2 cool staging with a third party DDC control system or thermostat
- Low voltage terminal block provides screw terminal connections for thermostat or controller wiring
- Night Setback Mode saves energy by closing outdoor air dampers and operating supply fan on thermostat demand only

#### Defrost Control

- Control furnished as standard
- Gives a demand defrost cycle whenever system heating performance falls below optimum levels
- The sensing element on coil determines when defrost cycle is required and when to terminate cycle
- Anti-short cycle (5 minutes) incorporated into the board
- Diagnostic LED's furnished as an aid in troubleshooting

**NOTE** - Gas heating operates during a defrost cycle.

#### Balance Point Thermostat

- Controls the changeover temperature between the heat pump heating operation and gas heat heating operation

#### Options/Accessories

#### Field Installed

##### Smoke Detector

- Photoelectric type
- Installed in supply air section, return air section or both sections
- Available with power board and single sensor (supply or return) or power board and two sensors (supply and return)
- Power board located in unit control compartment

#### Commercial Control Systems

##### L Connection® Network

- Complete building automation control system for single or multi-zone applications
- Options include local interface, software for local or remote communication, and hardware for networking other control functions
- See L Connection Network Product Specifications Bulletin for details

**NOTE** - Not available for Humiditrol® equipped units.

#### Thermostats

- Control system and thermostat options see page 11

### ELECTRICAL

#### Marked & Color-Coded Wiring

- All electrical wiring is color-coded and marked to identify which components it is connecting

#### Electrical Plugs

- Positive connection electrical plugs are used to connect common accessories or maintenance parts for easy removal or installation

#### Required Selections

##### Voltage Choice

- Specify when ordering base unit

#### Options/Accessories

#### Factory or Field Installed

##### Disconnect Switch up to 150 Amp

- Accessible from outside of unit
- Spring loaded weatherproof cover furnished

##### GFI Service Outlets (2)

- 115V ground fault circuit interrupter (GFCI) type
- Non-powered
- Field-wired

##### GFI Weatherproof Cover

- Single-gang cover
- Heavy-duty UV-resistant polycarbonate case construction
- Hinged base cover with gasket

## FEATURE AND BENEFITS

### INDOOR AIR QUALITY

- 14** Air Filters
- Disposable 2 inch filters furnished as standard

#### Options/Accessories

### Field Installed

#### Healthy Climate® High Efficiency Air Filters

- Disposable MERV 8 or MERV 13 (Minimum Efficiency Reporting Value based on ASHRAE 52.2) efficiency 2 inch pleated filters

#### Healthy Climate® UVC Germicidal Lamps

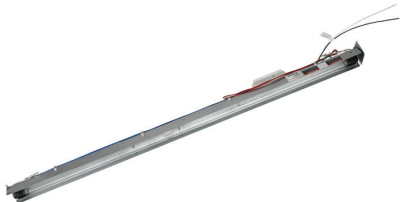

- Germicidal lamps emit ultra-violet (UV-C) energy, which has been proven to be effective in reducing microbes such as viruses, bacteria, yeasts, and molds
- This process either destroys the organism or controls its ability to reproduce
- UV-C energy greatly reduces the growth and proliferation of mold and other bioaerosols (bacteria and viruses) on illuminated surfaces (particularly coil and drain pan)
- Field installed in the blower/evaporator coil section
- Magnetic safety interlock terminates power when access panels are removed
- All necessary hardware for installation is included
- Lamps operate on 110/230V-1ph power supply

**NOTE** - Step-down transformer may be ordered separately for 460V and 575V units.

- Approved by ETL

#### Indoor Air Quality (CO<sub>2</sub>) Sensors

- Monitors CO<sub>2</sub> levels
- Reports to the Unit Controller which adjusts economizer dampers as needed.

## OPTIONS/ACCESSORIES

### ECONOMIZER

#### Factory or Field Installed

- 15** Economizer (Standard and High Performance Common Features)
- Combination Outdoor Air Hood is furnished
  - Factory installed Economizer can be ordered with two exhaust options:
    - Barometric Relief Dampers
    - No Exhaust
  - Field installed Economizer includes Barometric Relief Dampers with Combination Hood
  - Barometric Relief Dampers allow relief of excess air; dampers prevent blow back and outdoor air infiltration during off cycle, bird screen furnished

**NOTE** - Barometric Relief Dampers are required when Economizer is factory installed with field installed Power Exhaust Fan option. See Power Exhaust Fan section and Options/Accessories table.

- Occupied/Unoccupied mode with field furnished setback thermostat
- Demand Control Ventilation (DCV) ready using optional CO<sub>2</sub> sensors
- Mixed Air Sensor is furnished for field installation in the rooftop unit

**NOTE** - Sensor is factory installed when Economizers are factory installed.

- Single sensible sensor is furnished with Economizer and enables economizer operation if the outdoor temperature is less than the setpoint of the control
- Horizontal Barometric Dampers are required for horizontal Economizer applications and must be ordered separately

#### Standard Economizer Features (Not for Title 24)

- Gear-driven action
- Return air and outdoor air dampers
- Plug-in connections to unit
- Neoprene seals
- 24-volt, fully-modulating spring return motor



## OPTIONS/ACCESSORIES

### ECONOMIZER (continued)

#### Standard Economizer Control Module

- Standard Economizer Control Module can be adjusted to operate based on outdoor air temperatures



#### Economizer Controls:

- **Damper Minimum Position** - Can be set lower than traditional minimum air requirements resulting in cost savings
- **IAQ Sensor** - Signals dampers to modulate and maintain 55°F when CO<sub>2</sub> is higher than the CO<sub>2</sub> setpoint
- **Demand Control Ventilation (DCV) LED** - A steady green Demand Control Ventilation LED indicates the IAQ reading is higher than setpoint and requires more fresh air
- **Free Cool LED** - A steady green LED indicates outdoor air is suitable for free cooling
  - Free Cooling runs when outdoor air temperature is lower than the set temperature on the economizer control

**NOTE:** The Free Cooling default setting for outdoor air temperature sensor is 55°F.

#### High Performance Economizer Features

- Approved for California Title 24 building standards
- Low leakage dampers are Air Movement and Control Association International (AMCA) Class 1A Certified - Maximum 3 cfm per sq. ft. leakage at 1 in. w.g.
- ASHRAE 90.1 compliant
- Gear-driven action
- High torque 24-volt fully-modulating spring return damper motor
- Return air and outdoor air dampers
- Plug-in connections to unit
- Nylon bearings
- Enhanced thermoplastic vulcanizate (TPV) seals
- Flexible stainless steel jamb seals

**NOTE** - High Performance Economizers are not approved for use with enthalpy controls in Title 24 applications.

#### High Performance Economizer Control Module

- Module provides inputs and outputs to control economizer based on parameter settings
- Module automatically detects sensors by polling to determine which sensors are installed in system
- Module displays any alarm messages (fault detection and diagnostics) as an aid in troubleshooting
- Non-volatile memory retains parameter settings in case of power failure
- Keypad with four navigation buttons and LCD screen is furnished for setting economizer parameters:
  - Menu Up/Exit (⬆) button returns to the main menu
  - Arrow Up (▲) button moves to the previous or next parameter within the selected menu
  - Arrow Down (▼) button moves to the next parameter within the selected menu
  - Select (enter) (↵) button confirms parameter selection



#### Main Menu Structure:

- **Status** (economizer and system operation status)
- **Setpoints** (settings for various setpoint parameters)
- **System Setup** (settings/information about the system)
- **Advanced Setup** (freeze protection, CO<sub>2</sub> settings, stage 3 delay and additional calibration settings)
- **Checkout** (damper positions)
- **Alarms** (output signal that can be configured for remote alarm monitoring)

**NOTE** - The Free Cooling setpoint for Title 24 applications must be set based on the Climate Zone where the system is installed. See Section 140.4 "Prescriptive Requirements for Space Conditioning Systems" of the California Energy Commission's 2013 Building Energy Efficiency Standards.

**NOTE** - Refer to Installation Instructions for complete setup information and menu parameters available.

#### Factory or Field Installed

##### Single Enthalpy Temperature Control (Not for Title 24)

- Outdoor air enthalpy sensor enables Economizer if the outdoor enthalpy is less than the setpoint of the control

##### Field Installed

##### Differential Enthalpy Control (Not for Title 24)

- Order two Single Enthalpy Controls
- One is field installed in the return air section, the other in the outdoor air section
- Allows the economizer control board to select between outdoor air or return air, whichever has lower enthalpy

## OPTIONS/ACCESSORIES

### **EXHAUST**

#### **Field Installed**

##### **Horizontal Barometric Relief Dampers**

- For use when unit is configured for horizontal applications with an economizer
- Allows relief of excess air
- Blade type dampers prevent blow back and outdoor air infiltration during off cycle
- Field installed in return air duct
- Exhaust hood with bird screen furnished

**NOTE** - Requires Horizontal Economizer Conversion Kit.

##### **Horizontal Economizer Conversion Kit**

- Insulated panel covers the bottom return air opening on the unit base to convert downflow Economizer to horizontal airflow

#### **16 Power Exhaust Fan**

- Installs internal to unit for downflow applications only with Economizer option
- Provides exhaust air pressure relief
- Interlocked to run when supply air blower is operating, fan runs when outdoor air dampers are 50% open (adjustable)
- Motor is overload protected.
- 16 in. diameter fan
- 4 fan blades
- 1/3 hp motor

**NOTE** - Not available for 024 models.

**NOTE** - If Power Exhaust is field installed with a factory installed Economizer, the Economizer must be ordered with No Exhaust option. Barometric Relief Dampers must also be ordered separately for field installation.

### **OUTDOOR AIR**

#### **Factory or Field Installed**

##### **Outdoor Air Dampers - Downflow or Horizontal With Air Hood**

- Single blade damper
- 0 to 25% (fixed) outdoor air adjustable
- Installs in unit
- Includes outdoor air hood
- Automatic model features fully modulating spring return damper motor with plug-in connection
- Manual model features a slide damper
- Maximum mixed air temperature in cooling mode: 100°F

### **ROOF CURBS**

#### **Field Installed**

- Nailer strip furnished
- Mates to unit
- US National Roofing Contractors Approved
- Shipped knocked down

#### **Hybrid Roof Curbs**

- Downflow
- Interlocking tabs fasten corners together
- No tools required
- Can also be fastened together with furnished hardware
- Available in 8, 14, 18, and 24 inch heights

#### **Full Perimeter Curbs, Downflow (060 Models Only)**

- Hybrid roof curbs can be assembled using interlocking tabs to fasten corners together
- No tools required.
- Can also be fastened together with furnished hardware
- Available in 8, 14, 18, and 24 inch heights

**NOTE** - 060 models can be used on smaller 79-3/4 in. Hybrid Roof Curbs (not full perimeter) with 15-3/4 in. overhang at condenser end of unit. See dimension drawing on page 43.

#### **Adjustable Pitch Curb**

- Downflow
- Fully adjustable pitch curbs (3/4 in. per foot in any direction) provide a level platform for rooftop units allowing flexible installations on roofs with uneven or sloped angles
- Uses interlocking tabs to fasten corners together. No tools required
- Hardware is furnished to connect upper curb with lower curb
- Available in 14 inch height

#### **Adaptor Curbs (not shown)**

- Curbs are regionally sourced
- Dimensions vary based upon the source

**NOTE** - Contact your local sales representative for a detailed cut sheet with applicable dimensions.

### **CEILING DIFFUSERS**

#### **Field Installed**

##### **Ceiling Diffusers (Flush or Step-Down)**

- White powder coat finish on diffuser face and grilles
- Insulated UL listed duct liner
- Diffuser box has collars for duct connection
- Step-down diffusers have double deflection blades
- Flush diffusers have fixed blades
- Provisions for suspending
- Internally sealed to prevent recirculation
- Removable return air grille
- Adapts to T-bar ceiling grids or plaster ceilings

##### **Transitions (Supply and Return)**

- Used with diffusers
- Installs in roof curb
- Galvanized steel construction
- Flanges furnished for duct connection to diffusers
- Fully insulated

## OPTIONAL CONVENTIONAL TEMPERATURE CONTROL SYSTEMS

### ComfortSense® 7500 Commercial 7-Day Programmable Thermostat



- Four-Stage Heating / Two-Stage Cooling
- Universal Multi-Stage
- Intuitive Touchscreen Interface
- Automatic Changeover between Heating and Cooling
- Full Seven-Day Programming
- Four Time Periods Per Day
- Temperature and Humidity Control
- One-Touch Away Mode
- Holiday Scheduling
- Smooth Setback Recovery (SSR)
- Performance Reports
- Notifications/Reminders
- Dehumidification/Humiditrol® Control for Split Systems and Rooftop Units
- Economizer Relay Control
- Backlit Display
- Wallplate Furnished
- FDD, ASHRAE and IECC Compliant

### ComfortSense® 3000 Commercial 5-2 Day Programmable Thermostat

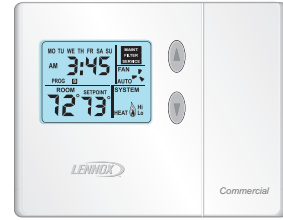

- Two-Stage Heating / Two-Stage Cooling
- Conventional Systems
- Intuitive Interface
- 5-2 Day Programming
- Program Hold
- Remote Indoor Temperature Sensing
- Smooth Setback Recovery (SSR)
- Economizer Relay Control
- Maintenance/Filter/Service Reminders
- Backlit Display
- Wallplate Furnished
- Simple Up and Down Temperature Control

### Bacnet Compatible Thermostat With Reheat Function



- 7-Day Programmable
- For units with or without Humiditrol®
- BTL listed MS/TP ensures compatibility with any BACnet system
- Built-in control programs for conventional and heat pump applications
- Conventional systems up to 3-stage heat and 3-stage cool
- Heat pumps with 1 or 2 compressors and up to 2-stage auxiliary heat
- On-board temperature and humidity sensor
- Multiple configurable inputs and outputs enable advanced control strategies
- Set-up Wizard enables rapid system configuration
- No special tools required for installation or commissioning
- Seven-day (2, 4 or 6 event) occupancy scheduling per day
- Backlit 5-inch LCD touchscreen

Description	Catalog No.
<b>ComfortSense® 7500 Commercial 7-Day Programmable Thermostat</b>	
CS7500 7-Day Thermostat	<b>17G74</b>
Sensors/	<sup>1</sup> Remote non-adjustable wall-mount 20k <b>47W36</b>
Accessories	<sup>1</sup> Remote non-adjustable wall-mount 10k <b>47W37</b>
	Remote non-adjustable discharge air (duct mount) <b>19L22</b>
	Outdoor temperature sensor <b>X2658</b>
<b>ComfortSense® 3000 5-2 Day Programmable</b>	
CS3000 5-2 Day Thermostat	<b>11Y05</b>
Sensor/	Remote non-adjustable wall mount 10k averaging <b>47W37</b>
Accessories	Thermostat wall mounting plate <b>X2659</b>
BACnet	<sup>2</sup> 7-Day BACnet Thermostat <b>Y8241</b>
Controls	<sup>3</sup> BACnet Module (factory or field) <b>16X70</b>
<sup>4</sup> BACnet	With Display <b>97W23</b>
Room Sensors	Without Display <b>97W24</b>
<b>Universal Thermostat Guard with Lock (clear)</b>	
	Inside Dimensions (H x W) 5 7/8 x 8 3/8 in. <b>39P21</b>

<sup>1</sup> Remote wall-mount sensors can be applied in any of the following combinations:  
 One Sensor - (1) 47W36, Two Sensors - (2) 47W37, Three Sensors - (2) 47W36 and (1) 47W37  
 Four Sensors - (4) 47W36, Five Sensors - (3) 47W36 and (2) 47W37

<sup>2</sup> BACnet Thermostat (Y8241) will control units with and without the Humiditrol® option. If there is a mix of units equipped with and without Humiditrol on the same site, this thermostat can be used for all units if suitable.

<sup>3</sup> Not compatible with units equipped with Humiditrol® option.

<sup>4</sup> Only compatible with BACnet Module (16X70).

## OPTIONS / ACCESSORIES

Item	Catalog No.	Unit Model No.				
		KDB 024	KDB 036	KDB 048	KDB 060	
<b>COOLING/HEATING SYSTEM</b>						
Condensate Drain Trap	PVC	<b>22H54</b>	X	X	X	X
	Copper	<b>76W27</b>	X	X	X	X
Drain Pan Overflow Switch		<b>74W42</b>	X	X	X	X
Low Ambient Kit		<b>15C84</b>	X	X	X	X
Efficiency	High		O	O	O	O
Refrigerant Type	R-410A		O	O	O	O
<b>GAS HEATING SYSTEM</b>						
Bottom Gas Piping Kit		<b>19W50</b>	X	X	X	X
Low Temperature Vestibule Heater	208/230V-1 or 3 ph	<b>19W53</b>	X	X	X	X
	460V-3ph	<b>19W54</b>		X	X	X
	575V-3ph	<b>19W62</b>		X	X	X
Combustion Air Intake Extensions		<b>19W51</b>	X	X	X	X
Gas Heat Input	Standard One-Stage - 65 kBtuh input	Factory	O			
	Standard Two-Stage - 53/70 kBtuh input	Factory		<sup>1</sup> O	<sup>1</sup> O	<sup>1</sup> O
	Medium Two Stage - 81/108 kBtuh input	Factory		O	O	O
	High Two-Stage - 113/150 kBtuh input	Factory			O	O
LPG/Propane Conversion Kits	For one-stage models	<b>21Z22</b>	X	X	X	X
	For two-stage standard models	<b>21Z24</b>		X	X	X
	For two-stage medium and high models	<b>21Z23</b>		X	X	X
Vertical Vent Extension		<b>31W62</b>	X	X	X	X
<b>BLOWER - SUPPLY AIR</b>						
Motors	Direct Drive - 0.33 hp (208/230V-1ph)	Factory	O			
	Direct Drive - 0.50 hp (208/230V-1ph, 208/230V-3ph, 460V-3ph, 575V-3ph)	Factory		O		
	Direct Drive - 0.75 hp (208/230V-1ph, 208/230V-3ph, 460V-3ph, 575V-3ph)	Factory			O	
	Direct Drive - 1.0 hp (208/230V-1ph, 208/230V-3ph, 460V-3ph, 575V-3ph)	Factory				O
	Belt Drive - 0.75 hp (208/230V, 460V, 575V-3ph) ( 2 Speed)	Factory		O	O	
	Belt Drive - 1 hp (208/230V, 460V, 575V-3ph) ( 2 Speed)	Factory		O		O
	Belt Drive - 2 hp (208/230V, 460V, 575V-3ph) (2 Speed)	Factory			O	O
Drive Kits See Blower Data Tables for selection	Kit A01 - T1DRKT001-1 - 673-1010 rpm	Factory		O		
	Kit A02 - T1DRKT002-1 - 745-1117 rpm	Factory			O	
	Kit A03 - T1DRKT003-1 - 833-1250 rpm	Factory				O
	Kit A05 - T1DRKT005-1 - 897-1346 rpm	Factory		O		
	Kit A06 - T1DRKT006-1 - 1071-1429 rpm	Factory			O	
	Kit A07 - T1DRKT007-1 - 1212-1548 rpm	Factory				O

<sup>1</sup> Standard Two-Stage Heat is only available with Low NOx option.

NOTE - The catalog numbers that appear here are for ordering field installed accessories only.

OX - Field Installed or Configure to Order (factory installed)

O - Configure to Order (Factory Installed)

X - Field Installed

## OPTIONS / ACCESSORIES

Item	Catalog No.	Unit Model No.			
		KDB 024	KDB 036	KDB 048	KDB 060
<b>CABINET</b>					
Combination Coil/Hail Guards	13R98	X	X		
	13T03			X	
	13T17				X
Corrosion Protection	Factory	O	O	O	O
Hinged Access Panels	Factory	O	O	O	O
<b>CONTROLS</b>					
<b>NOTE - Also see Conventional Thermostat Control Systems on page 11 for Additional Options.</b>					
Smoke Detector - Supply or Return (Power board and one sensor)	21Z11	X	X	X	X
Smoke Detector - Supply and Return (Power board and two sensors)	21Z12	X	X	X	X
L Connection® Building Automation System	---	X	X	X	X
<b>ECONOMIZER</b>					
<b>Standard Economizer With Outdoor Air Hood (Sensible Control) (Not for Title 24)</b>					
Standard Economizer - Includes Barometric Relief Dampers and Exhaust Hood	14D90	OX	OX	OX	OX
Economizer - No Exhaust	Factory	O	O	O	O
<b>Standard Economizer Controls (Not for Title 24)</b>					
Single Enthalpy Control	21Z09	OX	OX	OX	OX
Differential Enthalpy Control (order 2)	21Z09	X	X	X	X
<b>High Performance Economizer With Outdoor Air Hood (Sensible Control) (Approved for California Title 24 Building Standards / AMCA Class 1A Certified)</b>					
High Performance Economizer - Includes Barometric Relief Dampers and Exhaust Hood	20H49	OX	OX	OX	OX
High Performance Economizer - No Exhaust	Factory	O	O	O	O
<b>High Performance Economizer Controls (Not for Title 24)</b>					
Single Enthalpy Control	10Z75	OX	OX	OX	OX
Differential Enthalpy Control (order 2)	10Z75	X	X	X	X
<b>Economizer Accessories</b>					
Horizontal Economizer Conversion Kit	17W45	X	X	X	X
<b>POWER EXHAUST FAN</b>					
Standard Static	208/230V-1 or 3ph	21Z13		X	X
<i>NOTE - Field installed Power Exhaust Fan requires "Barometric Relief Dampers for Power Exhaust Kit" for field installation. See below.</i>	460V-3ph	21Z14		X	X
	575V-3ph	21Z15		X	X
<b>BAROMETRIC RELIEF</b>					
<sup>1</sup> Barometric Relief Dampers for Power Exhaust Kit		21Z21		X	X
<sup>2</sup> Horizontal Barometric Relief Dampers With Exhaust Hood		19F01	X	X	X
<sup>1</sup> Required when Economizer is factory installed with field installed Power Exhaust Fan option.					
<sup>2</sup> Required when Economizer is configured for horizontal airflow.					
NOTE - The catalog numbers that appear here are for ordering field installed accessories only.					
OX - Field Installed or Configure to Order (factory installed)					
O - Configure to Order (Factory Installed)					
X - Field Installed					

## OPTIONS / ACCESSORIES

Item	Catalog No.	Unit Model No.			
		KDB 024	KDB 036	KDB 048	KDB 060
<b>OUTDOOR AIR</b>					
<b>Outdoor Air Dampers - Includes Outdoor Air Hood</b>					
Motorized	15D17	OX	OX	OX	OX
Manual	15D18	OX	OX	OX	OX
<b>ELECTRICAL</b>					
Disconnect	See Electrical Data Tables for selection	OX	OX	OX	OX
Voltage	208/230V - 1 phase	O	O	O	O
60 hz	208/230V - 3 phase		O	O	O
	460V - 3 phase		O	O	O
	575V - 3 phase		O	O	O
GFI Service	15 amp non-powered, field-wired (208/230V, 460V only)	74M70	OX	OX	OX
Outlets	20 amp non-powered, field-wired (575V only)	67E01	X	X	X
Weatherproof Cover for GFI		10C89	X	X	X
<b>INDOOR AIR QUALITY</b>					
<b>Air Filters</b>					
Healthy Climate® High Efficiency Air Filters	MERV 8 (16 x 20 x 2)	54W20	X	X	
	MERV 13 (16 x 20 x 2)	52W37	X	X	
Order 4 per unit	MERV 8 (20 x 20 x 2)	54W21			X
	MERV 13 (20 x 20 x 2)	52W39			X
<b>Indoor Air Quality (CO<sub>2</sub>) Sensors</b>					
Sensor - Wall-mount, off-white plastic cover with LCD display		77N39	X	X	X
Sensor - Wall-mount, black plastic case, no display, rated for plenum mounting		87N54	X	X	X
CO <sub>2</sub> Sensor Duct Mounting Kit - for downflow applications		85L43	X	X	X
Aspiration Box - for duct mounting non-plenum rated CO <sub>2</sub> sensor (77N39)		90N43	X	X	X
<b>UVC Germicidal Lamps</b>					
<sup>1</sup> Healthy Climate® UVC Light Kit (110/230V-1ph)		21A92	X	X	X
Step-Down Transformers	460V primary, 230V secondary	10H20	X	X	X
	575V primary, 230V secondary	10H21	X	X	X
<b>ROOF CURBS</b>					
<b>Hybrid Roof Curbs, Downflow</b>					
8 in. height		11F50	X	X	X
14 in. height		11F51	X	X	X
18 in. height		11F52	X	X	X
24 in. height		11F53	X	X	X
<b>Hybrid Roof Curbs, Full Perimeter, Downflow</b>					
8 in. height		11S47			X
14 in. height		11S48			X
18 in. height		11T01			X
24 in. height		11T06			X
<b>Adjustable Pitch Curb, Downflow</b>					
14 in. height		43W27	X	X	X
<b>CEILING DIFFUSERS</b>					
Step-Down - Order one	RTD9-65S	13K60	X	X	X
	RTD11-95S	13K61			X
Flush - Order one	FD9-65S	13K55	X	X	X
	FD11-95S	13K56			X
Transitions (Supply and Return) - Order one	T1TRAN10AN1	17W53	X	X	X
	T1TRAN20N-1	17W54			X

<sup>1</sup> Lamps operate on 110-230V single-phase power supply. Step-down transformer may be ordered separately for 460V and 575V units. Alternately, 110V power supply may be used to directly power the UVC ballast(s).

<sup>2</sup> 060 models will fit smaller roof curbs with overhang. See dimension drawing.

NOTE - The catalog numbers that appear here are for ordering field installed accessories only.

OX - Field Installed or Configure to Order (factory installed)

O - Configure to Order (Factory Installed)

X - Field Installed

SPECIFICATIONS		DIRECT DRIVE BLOWER			
General Data		2 Ton	3 Ton	4 Ton	5 Ton
Nominal Tonnage		KDB024H4E	KDB036H4E	KDB048H4E	KDB060H4E
Model No.					
Efficiency Type		High	High	High	High
Blower Type		Direct Drive (ECM)	Direct Drive (ECM)	Direct Drive (ECM)	Direct Drive (ECM)
<b>Cooling Performance</b>	Gross Cooling Capacity - Btuh	23,800	35,700	46,800	59,400
	<sup>1</sup> Net Cooling Capacity - Btuh	23,600	35,200	46,000	58,000
	AHRI Rated Air Flow - cfm	800/560	1200/800	1430/1120	1650/1210
	<sup>2</sup> Sound Rating Number (SRN) (dBA)	74	75	77	77
	Total Unit Power - kW	1.8	2.8	3.6	4.7
	<sup>1</sup> SEER (Btuh/Watt)	16.5	16.0	16.0	16.0
	<sup>1</sup> EER (Btuh/Watt) - 208/230V	13.0	12.7	12.8	12.5
<sup>1</sup> EER (Btuh/Watt) - 460V/575V	13.0	12.4	12.8	12.5	
<b>Refrigerant</b>	Type	R-410A	R-410A	R-410A	R-410A
	Charge Furnished	13 lbs. 0 oz.	12 lbs. 13 oz.	14 lbs. 0 oz.	20 lbs. 0 oz.
<b>Heating Performance</b>	Total High Heating Capacity - Btuh	24,000	35,000	46,000	59,000
	Total Unit Power - kW	1.8	2.6	3.4	4.7
	<sup>1</sup> COP	3.88	3.90	3.90	3.70
	<sup>1</sup> HSPF - Region IV (Region V)	8.30	8.50	8.50	8.50
	Total Low Heating Capacity - Btuh	13,000	19,200	26,000	34,000
	Total Unit Power - kW	1.6	2.3	3.0	4.0
COP		2.34	2.40	2.46	2.46
<b>Gas Heating Options - See page 17</b>		<b>Standard (1 Stage)</b>	<b>Standard (2 Stage) or Medium (2 Stage)</b>	<b>Standard (2 Stage), Medium (2 Stage) or High (2 Stage)</b>	
<b>Compressor Type (one per unit)</b>		Two-Stage Scroll	Two-Stage Scroll	Two-Stage Scroll	Two-Stage Scroll
<b>Outdoor Coil</b>	Net face area - sq. ft.	15.6	15.6	19.3	28.0
	Tube diameter - in.	3/8	3/8	3/8	3/8
	Number of rows	2	2	2	2
	Fins / inch	20	20	20	20
<b>Outdoor Coil Fan</b>	Motor - (No.) HP	(1) 1/3	(1) 1/3	(1) 1/3	(1) 1/3
	Motor rpm	725/500	775/650	850/700	930/785
	Total Motor Input - watts	165/60	193/125	251/140	236/145
	Diameter - (No.) in. / No. of blades	24 - 3	24 - 3	24 - 3	24 - 3
	Total air volume - cfm	3340/2240	3500/2970	4060/3330	4135/3385
<b>Indoor Coil</b>	Net face area - sq. ft.	7.8	7.8	9.7	9.7
	Tube diameter - in.	3/8	3/8	3/8	3/8
	Number of rows	3	3	3	4
	Fins / inch	14	14	14	14
	Drain Connection (no.) and size - in.	(1) 1 NPT	(1) 1 NPT	(1) 1 NPT	(1) 1 NPT
	Expansion device type	Balanced Port Thermostatic Expansion Valve, removable power head			
<b>Indoor Blower</b>	Nominal Motor HP	0.33	0.50	0.75	1
	Wheel nom. diameter x width - in.	(1) 10 x 10	(1) 10 x 10	(1) 10 x 10	(1) 11 x 10
<b>Filters</b>	Type	Disposable		Disposable	
	Number and size - in.	(4) 16 x 20 x 2		(4) 20 x 20 x 2	
<b>Electrical Characteristics - 60 hz</b>		208/230V 1 phase	208/230V 1 phase  208/230V, 460V & 575V 3 phase	208/230V 1 phase  208/230V, 460V & 575V 3 phase	208/230V 1 phase  208/230V, 460V & 575V 3 phase

NOTE - Net capacity includes evaporator blower motor heat deduction. Gross capacity does not include evaporator blower motor heat deduction.

<sup>1</sup> AHRI Certified to AHRI Standard 210/240:

**Cooling Ratings** - 95°F outdoor air temperature and 80°F db/67°F wb entering indoor coil air.

**High Temperature Heating Ratings** - 47°F db/43°F wb outdoor air temperature and 70°F entering indoor coil air.

**Low Temperature Heating Ratings** - 17°F db/15°F wb outdoor air temperature and 70°F entering indoor coil air.

<sup>2</sup> Sound Rating Number (SRN) rated in accordance with test conditions included in AHRI Standard 270-95.

**SPECIFICATIONS**
**BELT DRIVE BLOWER**

General Data		Nominal Tonnage	3 Ton	4 Ton	5 Ton	
		Model No.	KDB036H4T	KDB048H4T	KDB060H4T	
		Efficiency Type	High	High	High	
		Blower Type	Two Speed Belt Drive	Two Speed Belt Drive	Two Speed Belt Drive	
<b>Cooling Performance</b>	Gross Cooling Capacity - Btuh		36,200	47,600	59,600	
	<sup>1</sup> Net Cooling Capacity - Btuh		35,000	46,000	57,500	
	AHRI Rated Air Flow - cfm		1200	1600	1800	
	<sup>2</sup> Sound Rating Number (SRN) (dBA)		75	77	77	
	Total Unit Power - kW		3.0	3.8	4.9	
	<sup>1</sup> SEER (Btuh/Watt) - 208/230V		15.0	15.0	15.0	
	<sup>1</sup> SEER (Btuh/Watt) - 460V/575V		14.8	14.8	15.0	
	<sup>1</sup> EER (Btuh/Watt) - 208/230V		12.0	12.0	12.0	
<sup>1</sup> EER (Btuh/Watt) - 460V/575V		11.8	11.9	11.8		
<b>Refrigerant</b>	Type		R-410A	R-410A	R-410A	
	Charge Furnished		12 lbs. 13 oz.	14 lbs. 0 oz.	20 lbs. 0 oz.	
<b>Heating Performance</b>	Total High Heating Capacity - Btuh		35,000	46,000	59,000	
	Total Unit Power - kW		2.8	3.5	4.7	
	<sup>1</sup> COP		3.64	3.82	3.64	
	HSPF - Region IV (Region V)		8.30	8.30	8.30	
	Total Low Heating Capacity - Btuh		19,200	26,000	34,000	
	Total Unit Power - kW		2.3	3.0	4.0	
	<sup>1</sup> COP		2.22	2.38	2.46	
<b>Gas Heating Options - See page 17</b>			<b>Standard (2 Stage) or Medium (2 Stage)</b>	<b>Standard (2 Stage), Medium (2 Stage) or High (2 Stage)</b>		
<b>Compressor Type (one per unit)</b>			Two-Stage Scroll	Two-Stage Scroll	Two-Stage Scroll	
<b>Outdoor Coil</b>	Net face area - sq. ft.		15.6	19.3	28.0	
	Tube diameter - in. - Number of rows		3/8 - 2	3/8 - 2	3/8 - 2	
	Fins / inch		20	20	20	
<b>Outdoor Coil Fan</b>	Motor - (No.) HP		1/3	1/3	1/3	
	Motor rpm		775/650	850/700	930/785	
	Total Motor Input - watts		195/125	251/140	235/145	
	Diameter - (No.) in. / No. of blades		24 - 3	24 - 3	24 - 3	
	Total air volume - cfm		3500/2970	4060/3330	4135/3385	
<b>Indoor Coil</b>	Net face area - sq. ft.		7.8	9.7	9.7	
	Tube diameter - in. - Number of rows		3/8 - 3	3/8 - 3	3/8 - 3	
	Fins / inch		14	14	14	
	Drain Connection (no.) and size - in.		(1) 1 NPT	(1) 1 NPT	(1) 1 NPT	
	Expansion device type		Balanced Port Thermostatic Expansion Valve, removable power head			
<sup>3</sup> <b>Indoor Blower &amp; Drive Selection</b>	Nominal Motor HP		0.75 hp (low), 1 hp (high)	0.75 hp (low), 2 hp (high)	1 hp (low), 2 hp (high)	
	Maximum Usable Motor HP		0.86 hp (low), 1.15 hp (high)	0.86 hp (low), 2.3 hp (high)	1.15 hp (low), 2.3 hp (high)	
	Available Drive Kits	A01		low 449-673 high 673-1010	A02 low 497-673 high 745-1117	A03 low 555-833 high 833-1250
		A05		low 598-897 high 897-1346	A06 low 714-953 high 1071-1429	A07 low 808-1032 high 1212-1548
		Wheel nominal diameter x width - in.		(1) 10 x 10	(1) 10 x 10	(1) 10 x 10
	<b>Filters</b>	Type		Disposable	Disposable	
Number and size - in.			(4) 16 x 20 x 2	(4) 20 x 20 x 2		
<b>Electrical Characteristics - 60 hz</b>			208/230V, 460V & 575V 3 phase	208/230V, 460V & 575V 3 phase	208/230V, 460V & 575V 3 phase	

NOTE - Net capacity includes evaporator blower motor heat deduction. Gross capacity does not include evaporator blower motor heat deduction.

<sup>1</sup> AHRI Certified to AHRI Standard 210/240:

**Cooling Ratings** - 95°F outdoor air temperature and 80°F db/67°F wb entering indoor coil air.

**High Temperature Heating Ratings** - 47°F db/43°F wb outdoor air temperature and 70°F entering indoor coil air.

**Low Temperature Heating Ratings** - 17°F db/15°F wb outdoor air temperature and 70°F entering indoor coil air.

<sup>2</sup> Sound Rating Number (SRN) rated in accordance with test conditions included in ARI Standard 270-95.

<sup>3</sup> Using total air volume and system static pressure requirements determine from blower performance tables rpm and motor hp required. Maximum usable hp of motors furnished are shown. In Canada, nominal motor hp is also maximum usable motor hp. If motors of comparable hp are used, be sure to keep within the service factor limitations outlined on the motor nameplate.



**SPECIFICATIONS - GAS HEAT**
**THREE PHASE MODELS**

Model No.		036, 048, 060	036, 048, 060	048, 060
Heat Input Type		Standard (2 Stage)	Medium (2 Stage)	High (2 Stage)
Input Btuh	1st Stage	53,000	81,000	113,000
	2nd Stage	70,000	108,000	150,000
Output Btuh	1st Stage	43,000	65,000	90,000
	2nd Stage	57,000	86,000	120,000
Temperature Rise Range - °F	1st stage	5 - 35	25 - 55	30 - 60
	2nd Stage	15 - 45	30 - 70	45 - 75
<sup>1</sup> Thermal Efficiency		80%	80%	80%
Gas Supply Connections		1/2 in. NPT		
Rec. Gas Supply Pressure - Nat./ LPG		7 in.w.g. / 11 in.w.g.		

<sup>1</sup> Thermal Efficiency at full input.

**SPECIFICATIONS - LOW NOX GAS HEAT**
**SINGLE AND THREE PHASE MODELS**

Model No.		024	036, 048, 060	036, 048, 060	048, 060
Heat Input Type		Standard (1 Stage)	Standard (2 Stage)	Medium (2 Stage)	High (2 Stage)
Input Btuh	1st Stage	65,000	53,000	81,000	113,000
	2nd Stage	---	70,000	108,000	150,000
Output Btuh	1st Stage	52,000	43,000	66,000	92,000
	2nd Stage	---	57,000	87,000	121,000
Temperature Rise Range - °F	1st stage	35 - 65	5 - 35	25 - 55	30 - 60
	2nd Stage	---	15 - 45	30 - 70	45 - 75
<sup>1</sup> AFUE (single phase)		81%	81%	81%	81%
<sup>2</sup> Thermal Efficiency (three phase)		---	81%	81%	81%
Gas Supply Connections		1/2 in. NPT			
Rec. Gas Supply Pressure - Nat./ LPG		7 in.w.g. / 11 in.w.g.			

<sup>1</sup> Annual Fuel Utilization Efficiency based on U.S. DOE test procedures and FTC labeling regulations - 1 phase models only.

<sup>2</sup> Thermal Efficiency at full input.

**HIGH ALTITUDE DERATE**

NOTE - Units may be installed at altitudes up to 2000 ft. above sea level without any modifications. At altitudes above 2000 ft. units must be derated to match information in the table shown. At altitudes above 4500 ft. unit must be derated 2% for each 1000 ft. above sea level.  
NOTE - This is the only permissible derate for these units.

Heat Input Type	Altitude Feet	Gas Manifold Pressure in. w.g.		Input Rate (Btuh)
		Natural Gas	LPG/ Propane	
Standard (1 stage)	2001 - 4500	3.0	9.0	60,000
Standard (2 stage)	2001 - 4500	3.0/1.7	9.0/5.1	65,000 / 49,000
Medium (2 stage)	2001 - 4500	3.0/1.7	9.0/5.1	100,000 / 75,000
High (2 stage)	2001 - 4500	3.0/1.7	9.0/5.1	139,000 / 104,000

## COOLING / HEATING RATINGS

NOTE – For Temperatures and Capacities not shown in tables, see bulletin – Cooling Unit Rating Table Correction Factor Data in Miscellaneous Engineering Data section.

### 2 TON COOLING HIGH EFFICIENCY KDB024H4 (1ST STAGE)

Entering Wet Bulb Temperature	Total Air Volume	Outdoor Air Temperature Entering Outdoor Coil																							
		65°F						75°F						85°F						95°F					
		Total Cool Cap.	Comp. Motor Input	Sensible To Total Ratio (S/T)			Total Cool Cap.	Comp. Motor Input	Sensible To Total Ratio (S/T)			Total Cool Cap.	Comp. Motor Input	Sensible To Total Ratio (S/T)			Total Cool Cap.	Comp. Motor Input	Sensible To Total Ratio (S/T)						
				Dry Bulb					Dry Bulb					Dry Bulb					Dry Bulb						
cfm	kBtuh	kW	75°F	80°F	85°F	kBtuh	kW	75°F	80°F	85°F	kBtuh	kW	75°F	80°F	85°F	kBtuh	kW	75°F	80°F	85°F					
63°F	450	17.9	.77	0.69	0.82	0.95	17.1	.89	0.69	0.83	0.96	16.0	1.03	0.70	0.85	0.99	14.8	1.20	0.71	0.87	1.00				
	560	19.2	.76	0.74	0.88	1.00	18.3	.88	0.74	0.90	1.00	17.1	1.02	0.76	0.92	1.00	15.8	1.19	0.77	0.96	1.00				
	670	20.2	.75	0.78	0.95	1.00	19.2	.87	0.79	0.97	1.00	17.9	1.02	0.81	1.00	1.00	16.7	1.18	0.84	1.00	1.00				
67°F	450	19.2	.76	0.55	0.67	0.78	18.3	.88	0.55	0.67	0.79	17.2	1.02	0.55	0.68	0.81	15.9	1.19	0.55	0.69	0.83				
	560	20.4	.75	0.58	0.71	0.85	19.4	.87	0.58	0.72	0.86	18.2	1.01	0.58	0.73	0.89	16.9	1.18	0.59	0.75	0.92				
	670	21.4	.74	0.60	0.76	0.91	20.3	.86	0.61	0.77	0.94	19.0	1.00	0.61	0.79	0.96	17.6	1.17	0.62	0.81	1.00				
71°F	450	20.5	.75	0.42	0.54	0.64	19.5	.87	0.42	0.53	0.65	18.3	1.01	0.41	0.54	0.66	17.0	1.18	0.40	0.54	0.67				
	560	21.8	.74	0.44	0.57	0.69	20.7	.86	0.43	0.57	0.70	19.5	1.00	0.42	0.57	0.71	18.0	1.16	0.42	0.58	0.73				
	670	22.8	.73	0.45	0.59	0.74	21.6	.85	0.45	0.60	0.75	20.3	.99	0.44	0.61	0.77	18.8	1.16	0.43	0.62	0.79				

### 2 TON COOLING HIGH EFFICIENCY KDB024H4 (2ND STAGE)

Entering Wet Bulb Temperature	Total Air Volume	Outdoor Air Temperature Entering Outdoor Coil																							
		85°F						95°F						105°F						115°F					
		Total Cool Cap.	Comp. Motor Input	Sensible To Total Ratio (S/T)			Total Cool Cap.	Comp. Motor Input	Sensible To Total Ratio (S/T)			Total Cool Cap.	Comp. Motor Input	Sensible To Total Ratio (S/T)			Total Cool Cap.	Comp. Motor Input	Sensible To Total Ratio (S/T)						
				Dry Bulb					Dry Bulb					Dry Bulb					Dry Bulb						
cfm	kBtuh	kW	75°F	80°F	85°F	kBtuh	kW	75°F	80°F	85°F	kBtuh	kW	75°F	80°F	85°F	kBtuh	kW	75°F	80°F	85°F					
63°F	640	22.6	1.39	0.71	0.86	1.00	20.8	1.55	0.72	0.88	1.00	18.9	1.74	0.73	0.91	1.00	16.9	1.97	0.75	0.95	1.00				
	800	24.0	1.39	0.77	0.94	1.00	22.2	1.56	0.79	0.97	1.00	20.3	1.75	0.81	1.00	1.00	18.5	1.97	0.83	1.00	1.00				
	960	25.3	1.40	0.83	1.00	1.00	23.6	1.56	0.85	1.00	1.00	21.7	1.75	0.88	1.00	1.00	19.8	1.98	0.92	1.00	1.00				
67°F	640	24.2	1.39	0.55	0.69	0.83	22.4	1.56	0.55	0.70	0.85	20.4	1.75	0.54	0.71	0.87	18.4	1.98	0.54	0.73	0.91				
	800	25.7	1.40	0.59	0.75	0.90	23.8	1.56	0.59	0.76	0.93	21.7	1.75	0.59	0.79	0.96	19.5	1.98	0.60	0.81	1.00				
	960	26.8	1.40	0.63	0.81	0.98	24.7	1.57	0.63	0.83	1.00	22.6	1.75	0.64	0.86	1.00	20.3	1.98	0.65	0.89	1.00				
71°F	640	25.9	1.40	0.41	0.54	0.67	24.0	1.56	0.39	0.54	0.68	22.0	1.75	0.39	0.54	0.69	20.0	1.98	0.36	0.54	0.71				
	800	27.5	1.40	0.43	0.58	0.73	25.5	1.57	0.41	0.58	0.75	23.3	1.76	0.40	0.59	0.76	21.1	1.98	0.38	0.60	0.79				
	960	28.6	1.41	0.44	0.62	0.79	26.5	1.57	0.44	0.63	0.81	24.2	1.76	0.43	0.64	0.84	21.8	1.98	0.42	0.65	0.87				

### 2 TON HEATING HIGH EFFICIENCY KDB024H4

Indoor Coil Air Volume 70°F Dry Bulb cfm	Air Temperature Entering Outdoor Coil									
	65°F		45°F		25°F		5°F		-15°F	
	Total Heating Capacity	Comp. Motor Input	Total Heating Capacity	Comp. Motor Input	Total Heating Capacity	Comp. Motor Input	Total Heating Capacity	Comp. Motor Input	Total Heating Capacity	Comp. Motor Input
640	29.8	1.80	22.1	1.66	14.2	1.51	8.6	1.35	4.4	1.02
800	30.4	1.69	22.7	1.54	14.8	1.39	9.2	1.24	4.9	0.90
960	30.7	1.62	23.1	1.47	15.1	1.33	9.5	1.17	5.3	0.83

## COOLING / HEATING RATINGS

NOTE – For Temperatures and Capacities not shown in tables, see bulletin – Cooling Unit Rating Table Correction Factor Data in Miscellaneous Engineering Data section.

### 3 TON COOLING HIGH EFFICIENCY KDB036H4 (1ST STAGE)

Entering Wet Bulb Temperature	Total Air Volume	Outdoor Air Temperature Entering Outdoor Coil																							
		65°F						75°F						85°F						95°F					
		Total Cool Cap.	Comp. Motor Input	Sensible To Total Ratio (S/T)			Total Cool Cap.	Comp. Motor Input	Sensible To Total Ratio (S/T)			Total Cool Cap.	Comp. Motor Input	Sensible To Total Ratio (S/T)			Total Cool Cap.	Comp. Motor Input	Sensible To Total Ratio (S/T)						
				Dry Bulb					Dry Bulb					Dry Bulb					Dry Bulb						
cfm	kBtuh	kW	75°F	80°F	85°F	kBtuh	kW	75°F	80°F	85°F	kBtuh	kW	75°F	80°F	85°F	kBtuh	kW	75°F	80°F	85°F					
63°F	640	26.3	1.10	0.68	0.81	0.94	24.8	1.25	0.69	0.83	0.97	23.1	1.44	0.70	0.85	1.00	21.4	1.67	0.71	0.87	1.00				
	800	28.1	1.08	0.73	0.88	1.00	26.4	1.24	0.74	0.90	1.00	24.7	1.43	0.75	0.93	1.00	22.9	1.67	0.77	0.97	1.00				
	960	29.4	1.07	0.78	0.96	1.00	27.7	1.23	0.79	0.98	1.00	26.0	1.43	0.81	1.00	1.00	24.3	1.66	0.84	1.00	1.00				
67°F	640	28.2	1.09	0.54	0.66	0.77	26.5	1.24	0.54	0.66	0.79	24.9	1.43	0.54	0.67	0.81	23.1	1.66	0.54	0.69	0.83				
	800	29.9	1.07	0.57	0.71	0.85	28.2	1.23	0.57	0.71	0.86	26.4	1.42	0.58	0.73	0.89	24.5	1.66	0.58	0.75	0.92				
	960	31.1	1.06	0.60	0.75	0.92	29.4	1.22	0.60	0.77	0.94	27.5	1.42	0.61	0.79	0.97	25.6	1.65	0.62	0.81	1.00				
71°F	640	29.9	1.07	0.42	0.53	0.63	28.3	1.23	0.41	0.53	0.64	26.6	1.42	0.40	0.53	0.65	24.8	1.66	0.40	0.53	0.66				
	800	31.8	1.06	0.43	0.56	0.68	30.1	1.22	0.42	0.56	0.69	28.2	1.41	0.42	0.56	0.71	26.3	1.65	0.42	0.57	0.72				
	960	33.1	1.05	0.44	0.59	0.73	31.4	1.21	0.44	0.59	0.74	29.5	1.41	0.44	0.60	0.76	27.4	1.64	0.43	0.61	0.78				

### 3 TON COOLING HIGH EFFICIENCY KDB036H4 (2ND STAGE)

Entering Wet Bulb Temperature	Total Air Volume	Outdoor Air Temperature Entering Outdoor Coil																							
		85°F						95°F						105°F						115°F					
		Total Cool Cap.	Comp. Motor Input	Sensible To Total Ratio (S/T)			Total Cool Cap.	Comp. Motor Input	Sensible To Total Ratio (S/T)			Total Cool Cap.	Comp. Motor Input	Sensible To Total Ratio (S/T)			Total Cool Cap.	Comp. Motor Input	Sensible To Total Ratio (S/T)						
				Dry Bulb					Dry Bulb					Dry Bulb					Dry Bulb						
cfm	kBtuh	kW	75°F	80°F	85°F	kBtuh	kW	75°F	80°F	85°F	kBtuh	kW	75°F	80°F	85°F	kBtuh	kW	75°F	80°F	85°F					
63°F	960	34.0	2.14	0.70	0.86	1.00	31.5	2.40	0.71	0.88	1.00	28.9	2.72	0.73	0.91	1.00	26.1	3.08	0.75	0.95	1.00				
	1200	36.1	2.15	0.76	0.94	1.00	33.5	2.42	0.78	0.97	1.00	30.7	2.73	0.81	1.00	1.00	28.0	3.09	0.84	1.00	1.00				
	1440	37.8	2.16	0.83	1.00	1.00	35.4	2.43	0.85	1.00	1.00	32.7	2.74	0.88	1.00	1.00	29.9	3.10	0.92	1.00	1.00				
67°F	960	36.4	2.15	0.55	0.68	0.82	33.9	2.42	0.55	0.69	0.84	31.1	2.73	0.55	0.71	0.87	28.1	3.09	0.55	0.72	0.91				
	1200	38.5	2.17	0.58	0.74	0.91	35.7	2.43	0.59	0.76	0.94	32.8	2.74	0.59	0.78	0.97	29.5	3.10	0.60	0.81	1.00				
	1440	40.0	2.18	0.62	0.81	0.98	37.0	2.44	0.63	0.83	1.00	34.0	2.75	0.64	0.85	1.00	30.7	3.10	0.65	0.89	1.00				
71°F	960	38.8	2.17	0.41	0.53	0.66	36.2	2.43	0.40	0.54	0.67	33.3	2.74	0.39	0.54	0.69	30.2	3.10	0.37	0.54	0.70				
	1200	41.0	2.19	0.42	0.57	0.72	38.1	2.45	0.42	0.58	0.74	35.1	2.75	0.41	0.59	0.76	31.8	3.11	0.40	0.60	0.79				
	1440	42.5	2.20	0.44	0.61	0.78	39.5	2.46	0.44	0.62	0.81	36.4	2.76	0.43	0.63	0.83	32.9	3.12	0.43	0.65	0.87				

### 3 TON HEATING HIGH EFFICIENCY KDB036H4

Indoor Coil Air Volume 70°F Dry Bulb cfm	Air Temperature Entering Outdoor Coil									
	65°F		45°F		25°F		5°F		-15°F	
	Total Heating Capacity	Comp. Motor Input	Total Heating Capacity	Comp. Motor Input	Total Heating Capacity	Comp. Motor Input	Total Heating Capacity	Comp. Motor Input	Total Heating Capacity	Comp. Motor Input
	kBtuh	kW	kBtuh	kW	kBtuh	kW	kBtuh	kW	kBtuh	kW
960	43.8	2.62	32.6	2.44	20.9	2.25	13.3	1.99	6.8	1.50
1200	44.4	2.45	33.2	2.26	21.6	2.07	13.9	1.82	7.4	1.33
1440	45.0	2.35	33.8	2.16	22.1	1.97	14.5	1.72	8.0	1.22

## COOLING / HEATING RATINGS

NOTE – For Temperatures and Capacities not shown in tables, see bulletin – Cooling Unit Rating Table Correction Factor Data in Miscellaneous Engineering Data section.

### 4 TON COOLING HIGH EFFICIENCY KDB048H4 (1ST STAGE)

Entering Wet Bulb Temperature	Total Air Volume	Outdoor Air Temperature Entering Outdoor Coil																							
		65°F						75°F						85°F						95°F					
		Total Cool Cap.	Comp. Motor Input	Sensible To Total Ratio (S/T)			Total Cool Cap.	Comp. Motor Input	Sensible To Total Ratio (S/T)			Total Cool Cap.	Comp. Motor Input	Sensible To Total Ratio (S/T)			Total Cool Cap.	Comp. Motor Input	Sensible To Total Ratio (S/T)						
				Dry Bulb					Dry Bulb					Dry Bulb					Dry Bulb						
cfm	kBtuh	kW	75°F	80°F	85°F	kBtuh	kW	75°F	80°F	85°F	kBtuh	kW	75°F	80°F	85°F	kBtuh	kW	75°F	80°F	85°F					
63°F	895	35.9	1.43	0.70	0.83	0.96	34.0	1.68	0.71	0.85	0.98	31.9	1.97	0.72	0.87	1.00	29.6	2.29	0.74	0.89	1.00				
	1120	38.0	1.41	0.75	0.90	1.00	36.1	1.66	0.76	0.92	1.00	34.0	1.95	0.78	0.95	1.00	31.5	2.27	0.80	0.98	1.00				
	1345	39.9	1.39	0.80	0.97	1.00	37.9	1.65	0.82	0.99	1.00	35.7	1.94	0.84	1.00	1.00	33.5	2.26	0.87	1.00	1.00				
67°F	895	38.2	1.41	0.56	0.68	0.80	36.3	1.66	0.69	0.81	0.91	34.1	1.95	0.56	0.70	0.83	31.7	2.27	0.56	0.71	0.86				
	1120	40.6	1.39	0.59	0.73	0.87	38.5	1.65	0.59	0.74	0.89	36.2	1.94	0.60	0.76	0.91	33.6	2.26	0.61	0.78	0.94				
	1345	42.4	1.38	0.62	0.78	0.93	40.2	1.64	0.63	0.79	0.96	37.7	1.93	0.64	0.81	0.98	35.0	2.25	0.64	0.84	1.00				
71°F	895	40.6	1.39	0.43	0.54	0.66	38.6	1.65	0.42	0.54	0.66	36.4	1.94	0.42	0.55	0.67	33.8	2.26	0.41	0.55	0.69				
	1120	43.0	1.37	0.44	0.57	0.71	41.0	1.63	0.44	0.58	0.72	38.5	1.92	0.43	0.59	0.73	35.9	2.25	0.43	0.60	0.75				
	1345	44.9	1.36	0.45	0.61	0.76	42.8	1.62	0.45	0.62	0.77	40.1	1.92	0.45	0.63	0.79	37.3	2.24	0.45	0.64	0.81				

### 4 TON COOLING HIGH EFFICIENCY KDB048H4 (2ND STAGE)

Entering Wet Bulb Temperature	Total Air Volume	Outdoor Air Temperature Entering Outdoor Coil																							
		85°F						95°F						105°F						115°F					
		Total Cool Cap.	Comp. Motor Input	Sensible To Total Ratio (S/T)			Total Cool Cap.	Comp. Motor Input	Sensible To Total Ratio (S/T)			Total Cool Cap.	Comp. Motor Input	Sensible To Total Ratio (S/T)			Total Cool Cap.	Comp. Motor Input	Sensible To Total Ratio (S/T)						
				Dry Bulb					Dry Bulb					Dry Bulb					Dry Bulb						
cfm	kBtuh	kW	75°F	80°F	85°F	kBtuh	kW	75°F	80°F	85°F	kBtuh	kW	75°F	80°F	85°F	kBtuh	kW	75°F	80°F	85°F					
63°F	1280	45.4	2.77	0.72	0.86	1.00	42.1	3.12	0.73	0.88	1.00	38.5	3.53	0.74	0.92	1.00	34.9	4.02	0.76	0.96	1.00				
	1600	48.1	2.78	0.78	0.95	1.00	44.7	3.14	0.79	0.98	1.00	41.1	3.55	0.82	1.00	1.00	37.5	4.04	0.85	1.00	1.00				
	1920	50.5	2.79	0.84	1.00	1.00	47.2	3.15	0.86	1.00	1.00	43.7	3.58	0.89	1.00	1.00	40	4.07	0.93	1.00	1.00				
67°F	1280	48.3	2.78	0.56	0.69	0.83	44.9	3.14	0.55	0.70	0.85	41.2	3.55	0.56	0.72	0.88	37.4	4.04	0.56	0.74	0.92				
	1600	51.1	2.8	0.59	0.76	0.92	47.4	3.16	0.60	0.77	0.95	43.5	3.57	0.61	0.80	0.98	39.4	4.06	0.62	0.83	1.00				
	1920	53.1	2.81	0.63	0.82	0.99	49.2	3.17	0.64	0.84	1.00	45.1	3.59	0.65	0.87	1.00	40.8	4.08	0.67	0.91	1.00				
71°F	1280	51.4	2.8	0.41	0.54	0.67	47.8	3.16	0.40	0.55	0.68	44	3.58	0.39	0.55	0.70	40	4.07	0.38	0.56	0.72				
	1600	54.2	2.81	0.43	0.59	0.74	50.2	3.17	0.42	0.59	0.75	46.3	3.59	0.42	0.60	0.78	42	4.09	0.41	0.61	0.81				
	1920	56.1	2.83	0.45	0.63	0.80	52.1	3.19	0.45	0.64	0.82	47.6	3.6	0.44	0.65	0.85	43.3	4.1	0.44	0.67	0.89				

### 4 TON HEATING HIGH EFFICIENCY KDB048H4

Indoor Coil Air Volume 70°F Dry Bulb cfm	Air Temperature Entering Outdoor Coil									
	65°F		45°F		25°F		5°F		-15°F	
	Total Heating Capacity	Comp. Motor Input	Total Heating Capacity	Comp. Motor Input	Total Heating Capacity	Comp. Motor Input	Total Heating Capacity	Comp. Motor Input	Total Heating Capacity	Comp. Motor Input
	kBtuh	kW	kBtuh	kW	kBtuh	kW	kBtuh	kW	kBtuh	kW
1280	57.0	3.22	42.5	2.99	27.4	2.76	17.6	2.43	8.8	1.83
1600	58.0	3.01	43.5	2.79	28.4	2.56	18.6	2.23	9.8	1.63
1920	58.8	2.89	44.3	2.67	29.2	2.44	19.4	2.11	10.6	1.51

# COOLING / HEATING RATINGS

NOTE – For Temperatures and Capacities not shown in tables, see bulletin – Cooling Unit Rating Table Correction Factor Data in Miscellaneous Engineering Data section.

## 5 TON COOLING HIGH EFFICIENCY KDB060H4 (1ST STAGE)

Entering Wet Bulb Temperature	Total Air Volume	Outdoor Air Temperature Entering Outdoor Coil																							
		65°F						75°F						85°F						95°F					
		Total Cool Cap.	Comp. Motor Input	Sensible To Total Ratio (S/T)			Total Cool Cap.	Comp. Motor Input	Sensible To Total Ratio (S/T)			Total Cool Cap.	Comp. Motor Input	Sensible To Total Ratio (S/T)			Total Cool Cap.	Comp. Motor Input	Sensible To Total Ratio (S/T)						
				Dry Bulb					Dry Bulb					Dry Bulb					Dry Bulb						
cfm	kBtuh	kW	75°F	80°F	85°F	kBtuh	kW	75°F	80°F	85°F	kBtuh	kW	75°F	80°F	85°F	kBtuh	kW	75°F	80°F	85°F					
63°F	1080	46.1	1.83	0.70	0.82	0.95	44.4	2.14	0.70	0.83	0.97	42.4	2.48	0.72	0.86	0.99	40.1	2.87	0.74	0.89	1.00				
	1350	48.7	1.81	0.74	0.89	1.00	46.9	2.12	0.75	0.91	1.00	44.8	2.47	0.77	0.94	1.00	42.3	2.86	0.80	0.97	1.00				
	1620	50.8	1.80	0.79	0.96	1.00	48.9	2.11	0.80	0.98	1.00	46.6	2.45	0.82	1.00	1.00	44.3	2.84	0.86	1.00	1.00				
67°F	1080	49.0	1.81	0.55	0.67	0.78	47.3	2.12	0.56	0.68	0.80	45.1	2.46	0.57	0.69	0.82	42.8	2.85	0.59	0.71	0.84				
	1350	51.8	1.79	0.58	0.72	0.85	49.8	2.10	0.59	0.73	0.87	47.6	2.45	0.60	0.75	0.90	45.0	2.84	0.62	0.77	0.93				
	1620	53.9	1.78	0.61	0.76	0.92	51.8	2.09	0.62	0.78	0.94	49.2	2.44	0.63	0.80	0.97	46.5	2.83	0.65	0.83	1.00				
71°F	1080	52.1	1.79	0.43	0.53	0.64	50.3	2.10	0.43	0.54	0.65	48.1	2.45	0.43	0.55	0.67	45.6	2.84	0.44	0.57	0.68				
	1350	55.0	1.77	0.44	0.57	0.69	52.9	2.08	0.44	0.57	0.70	50.5	2.43	0.45	0.58	0.72	47.7	2.82	0.46	0.60	0.74				
	1620	57.1	1.76	0.45	0.60	0.74	54.9	2.07	0.46	0.61	0.75	52.3	2.42	0.46	0.62	0.77	49.3	2.82	0.47	0.63	0.80				

## 5 TON COOLING HIGH EFFICIENCY KDB060H4 (2ND STAGE)

Entering Wet Bulb Temperature	Total Air Volume	Outdoor Air Temperature Entering Outdoor Coil																							
		85°F						95°F						105°F						115°F					
		Total Cool Cap.	Comp. Motor Input	Sensible To Total Ratio (S/T)			Total Cool Cap.	Comp. Motor Input	Sensible To Total Ratio (S/T)			Total Cool Cap.	Comp. Motor Input	Sensible To Total Ratio (S/T)			Total Cool Cap.	Comp. Motor Input	Sensible To Total Ratio (S/T)						
				Dry Bulb					Dry Bulb					Dry Bulb					Dry Bulb						
cfm	kBtuh	kW	75°F	80°F	85°F	kBtuh	kW	75°F	80°F	85°F	kBtuh	kW	75°F	80°F	85°F	kBtuh	kW	75°F	80°F	85°F					
63°F	1600	58.5	3.50	0.71	0.86	1.00	54.4	3.93	0.71	0.88	1.00	50.0	4.41	0.73	0.91	1.00	45.4	4.98	0.75	0.95	1.00				
	2000	62.0	3.53	0.76	0.95	1.00	57.9	3.96	0.79	0.98	1.00	53.4	4.45	0.81	1.00	1.00	49.0	5.02	0.84	1.00	1.00				
	2400	65.2	3.56	0.83	1.00	1.00	61.2	3.99	0.85	1.00	1.00	56.9	4.49	0.88	1.00	1.00	52.3	5.06	0.92	1.00	1.00				
67°F	1600	62.9	3.54	0.55	0.68	0.82	58.6	3.97	0.54	0.69	0.84	54.2	4.46	0.55	0.71	0.87	49.1	5.02	0.55	0.73	0.91				
	2000	66.4	3.57	0.58	0.74	0.91	61.9	4.00	0.59	0.76	0.94	57.2	4.49	0.60	0.78	0.98	51.9	5.05	0.60	0.81	1.00				
	2400	69.1	3.60	0.62	0.81	0.99	64.4	4.02	0.63	0.83	1.00	59.3	4.51	0.63	0.85	1.00	54.0	5.08	0.65	0.90	1.00				
71°F	1600	67.5	3.58	0.40	0.53	0.66	63.2	4.01	0.40	0.53	0.67	58.5	4.50	0.39	0.54	0.68	53.3	5.06	0.38	0.54	0.70				
	2000	71.1	3.61	0.42	0.57	0.72	66.6	4.04	0.42	0.58	0.73	61.5	4.53	0.41	0.59	0.76	56.2	5.10	0.40	0.60	0.79				
	2400	73.8	3.64	0.44	0.61	0.78	68.9	4.06	0.44	0.62	0.80	63.6	4.56	0.43	0.64	0.83	58.1	5.13	0.43	0.64	0.87				

## 5 TON HEATING HIGH EFFICIENCY KDB060H4

Indoor Coil Air Volume 70°F Dry Bulb cfm	Air Temperature Entering Outdoor Coil												
	65°F			45°F			25°F			5°F		-15°F	
	Total Heating Capacity	Comp. Motor Input	Total Heating Capacity	Comp. Motor Input	Total Heating Capacity	Comp. Motor Input	Total Heating Capacity	Comp. Motor Input	Total Heating Capacity	Comp. Motor Input	Total Heating Capacity	Comp. Motor Input	
													kBtuh
1600	72.6	4.07	55.2	3.81	37.4	3.55	23.1	3.17	11.6	2.38			
2000	73.8	3.81	56.4	3.55	38.6	3.29	24.3	2.91	12.8	2.12			
2400	74.8	3.64	57.3	3.39	39.5	3.13	25.2	2.75	13.7	1.96			

**BLOWER DATA****DIRECT DRIVE - HIGH EFFICIENCY - 2 TON****BLOWER TABLE INCLUDES RESISTANCE FOR BASE UNIT ONLY WITH DRY INDOOR COIL AND AIR FILTERS IN PLACE.**

FOR ALL UNITS ADD:

1 - Any factory installed options air resistance (economizer, wet coil, etc.) See page 32.

2 - Any field installed accessories air resistance (electric heat, duct resistance, diffuser, etc.) See page 32.

External Static Pressure in. w.g.	Air Volume at Specific Blower Taps (cfm)				
	Tap 1	Tap 2	Tap 3	Tap 4	Tap 5
<b>DOWNFLOW</b>					<b>KDB024H4E</b>
0.0	635	728	918	1121	1336
0.1	547	689	861	1071	1290
0.2	433	607	806	1031	1253
0.3	371	528	749	986	1212
0.4	280	460	677	927	1166
0.5	217	380	605	868	1120
0.6	---	---	548	819	1071
0.7	---	---	491	773	1029
0.8	---	---	442	714	983
0.9	---	---	393	653	929
1.0	---	---	---	604	879
<b>HORIZONTAL</b>					<b>KDB024H4E</b>
0.0	602	715	908	1096	1302
0.1	509	663	852	1057	1263
0.2	413	588	793	1007	1227
0.3	340	507	736	964	1189
0.4	266	438	679	918	1142
0.5	220	355	620	864	1100
0.6	---	---	560	809	1061
0.7	---	---	500	752	1015
0.8	---	---	444	706	964
0.9	---	---	390	661	913
1.0	---	---	352	612	872

**BLOWER DATA****DIRECT DRIVE - HIGH EFFICIENCY - 3 TON****BLOWER TABLE INCLUDES RESISTANCE FOR BASE UNIT ONLY WITH DRY INDOOR COIL AND AIR FILTERS IN PLACE.**

FOR ALL UNITS ADD:

1 - Any factory installed options air resistance (economizer, wet coil, etc.) See page 32.

2 - Any field installed accessories air resistance (electric heat, duct resistance, diffuser, etc.) See page 32.

External Static Pressure in. w.g.	Air Volume at Specific Blower Taps (cfm)					
	Tap 1	Tap 2	Tap 3	Tap 4	Tap 5	
<b>DOWNFLOW</b>						<b>KDB036H4E</b>
0.0	893	1035	1375	1600	1840	
0.1	838	965	1330	1574	1780	
0.2	768	895	1277	1543	1748	
0.3	705	800	1253	1505	1712	
0.4	645	750	1200	1473	1677	
0.5	575	690	1150	1435	1638	
0.6	---	---	1095	1390	1608	
0.7	---	---	1052	1345	1577	
0.8	---	---	1004	1302	1528	
0.9	---	---	950	1260	1491	
1.0	---	---	900	1218	1455	
<b>HORIZONTAL</b>						<b>KDB036H4E</b>
0.0	900	1045	1379	1599	1810	
0.1	828	970	1305	1549	1749	
0.2	777	900	1264	1504	1718	
0.3	702	800	1216	1479	1677	
0.4	635	750	1173	1434	1649	
0.5	553	685	1131	1399	1622	
0.6	---	---	1078	1359	1577	
0.7	---	---	1038	1315	1544	
0.8	---	---	986	1280	1509	
0.9	---	---	933	1236	1471	
1.0	---	---	885	1196	1438	

**BLOWER DATA****DIRECT DRIVE - HIGH EFFICIENCY - 4 TON****BLOWER TABLE INCLUDES RESISTANCE FOR BASE UNIT ONLY WITH DRY INDOOR COIL AND AIR FILTERS IN PLACE.**

FOR ALL UNITS ADD:

1 - Any factory installed options air resistance (economizer, wet coil, etc.) See page 32.

2 - Any field installed accessories air resistance (electric heat, duct resistance, diffuser, etc.) See page 32.

External Static Pressure in. w.g.	Air Volume at Specific Blower Taps (cfm)				
	Tap 1	Tap 2	Tap 3	Tap 4	Tap 5
<b>DOWNFLOW</b>					<b>KDB048H4E</b>
0.0	1225	1310	1561	2015	2168
0.1	1167	1254	1514	1995	2143
0.2	1112	1203	1473	1977	2126
0.3	1052	1145	1424	1942	2097
0.4	1000	1098	1387	1917	2078
0.5	939	1040	1343	1888	2049
0.6	894	996	1300	1854	2020
0.7	840	941	1250	1819	1991
0.8	780	883	1201	1787	1952
0.9	734	839	1159	1749	1914
1.0	681	784	1115	1704	1856
<b>HORIZONTAL</b>					<b>KDB048H4E</b>
0.0	1185	1265	1504	1983	2120
0.1	1130	1213	1467	1957	2098
0.2	1085	1171	1432	1932	2077
0.3	1035	1125	1395	1906	2054
0.4	978	1069	1347	1870	2023
0.5	929	1023	1304	1841	1992
0.6	880	977	1267	1811	1962
0.7	822	920	1224	1776	1931
0.8	764	863	1175	1740	1900
0.9	718	820	1133	1710	1869
1.0	549	712	1096	1652	1772



**BLOWER DATA****DIRECT DRIVE - HIGH EFFICIENCY - 5 TON****BLOWER TABLE INCLUDES RESISTANCE FOR BASE UNIT ONLY WITH DRY INDOOR COIL AND AIR FILTERS IN PLACE.**

FOR ALL UNITS ADD:

1 - Any factory installed options air resistance (economizer, wet coil, etc.) See page 32.

2 - Any field installed accessories air resistance (electric heat, duct resistance, diffuser, etc.) See page 32.

External Static Pressure in. w.g.	Air Volume at Specific Blower Taps (cfm)					
	Tap 1	Tap 2	Tap 3	Tap 4	Tap 5	
<b>DOWNFLOW</b>						<b>KDB060H4E</b>
0.0	1351	1405	1801	1982	2339	
0.1	1303	1359	1769	1956	2310	
0.2	1254	1314	1736	1928	2281	
0.3	1206	1268	1703	1900	2253	
0.4	1158	1222	1669	1870	2224	
0.5	1109	1177	1634	1838	2195	
0.6	1061	1131	1598	1806	2166	
0.7	1012	1085	1561	1772	2137	
0.8	964	1040	1524	1736	2108	
0.9	915	994	1486	1700	2080	
1.0	867	949	1446	1662	2051	
<b>HORIZONTAL</b>						<b>KDB60H4E</b>
0.0	1329	1353	1728	1886	2206	
0.1	1284	1320	1708	1872	2189	
0.2	1239	1285	1685	1859	2174	
0.3	1193	1258	1661	1832	2157	
0.4	1147	1218	1636	1814	2135	
0.5	1100	1178	1608	1796	2118	
0.6	1052	1125	1579	1770	2102	
0.7	1004	1085	1548	1743	2080	
0.8	955	1044	1516	1716	2058	
0.9	906	991	1481	1689	2036	
1.0	856	938	1445	1654	2020	

**BLOWER DATA**

**BELT DRIVE - 3 TON**

**BLOWER TABLE INCLUDES RESISTANCE FOR BASE UNIT ONLY WITH DRY INDOOR COIL AND AIR FILTERS IN PLACE.**

FOR ALL UNITS ADD:

1 - Any factory installed options air resistance (larger gas heat section, economizer, wet coil, etc.).

2 - Any field installed accessories air resistance (duct resistance, diffuser, etc.).

See page 32 for blower motors and drives and page 32 for wet coil and options/accessory air resistance data.

**DOWNFLOW**

**KDB036H4T**

Air Volume cfm	External Static - in. w.g.															
	0.10		0.20		0.30		0.40		0.50		0.60		0.70		0.80	
	RPM	BHP	RPM	BHP	RPM	BHP	RPM	BHP	RPM	BHP	RPM	BHP	RPM	BHP	RPM	BHP
700	447	0.09	517	0.12	589	0.15	663	0.17	739	0.19	815	0.20	883	0.23	938	0.25
800	465	0.10	534	0.14	605	0.17	678	0.19	753	0.21	825	0.23	890	0.25	946	0.27
900	486	0.12	554	0.16	623	0.20	695	0.22	767	0.23	836	0.25	897	0.28	953	0.30
1000	508	0.15	576	0.19	643	0.22	713	0.24	783	0.26	848	0.28	907	0.30	961	0.33
1100	533	0.18	599	0.22	665	0.25	733	0.27	800	0.28	863	0.31	919	0.34	971	0.36
1200	560	0.21	625	0.25	689	0.28	755	0.30	820	0.32	879	0.34	932	0.37	983	0.40
1300	591	0.24	654	0.28	716	0.31	779	0.33	841	0.35	897	0.38	948	0.41	996	0.44
1400	631	0.26	690	0.30	748	0.34	807	0.36	864	0.39	916	0.42	964	0.46	1011	0.49
1500	676	0.28	729	0.33	782	0.36	835	0.40	887	0.43	935	0.47	981	0.50	1028	0.54

Air Volume cfm	External Static - in. w.g.															
	0.90		1.00		1.10		1.20		1.30		1.40		1.50		1.60	
	RPM	BHP	RPM	BHP	RPM	BHP	RPM	BHP	RPM	BHP	RPM	BHP	RPM	BHP	RPM	BHP
700	988	0.27	1039	0.29	1088	0.31	---	---	---	---	---	---	---	---	---	---
800	996	0.30	1047	0.32	1098	0.34	1144	0.36	1185	0.39	1224	0.42	---	---	---	---
900	1004	0.33	1055	0.35	1106	0.37	1152	0.40	1193	0.43	1232	0.46	1269	0.49	1305	0.52
1000	1011	0.36	1062	0.38	1111	0.41	1157	0.43	1199	0.47	1238	0.50	1276	0.53	1311	0.56
1100	1020	0.39	1070	0.41	1118	0.44	1163	0.47	1206	0.51	1245	0.54	1282	0.58	1318	0.61
1200	1031	0.43	1079	0.45	1127	0.48	1171	0.52	1213	0.55	1252	0.59	1289	0.62	1324	0.66
1300	1044	0.47	1091	0.49	1137	0.53	1181	0.56	1221	0.60	1259	0.64	1296	0.68	1330	0.71
1400	1058	0.51	1105	0.54	1150	0.57	1191	0.61	1231	0.65	1268	0.69	1303	0.73	1337	0.77
1500	1074	0.56	1120	0.59	1163	0.63	1203	0.67	1241	0.71	1277	0.75	1312	0.79	1345	0.82

**BLOWER DATA**

**BELT DRIVE - 3 TON**

**BLOWER TABLE INCLUDES RESISTANCE FOR BASE UNIT ONLY WITH DRY INDOOR COIL AND AIR FILTERS IN PLACE.**

FOR ALL UNITS ADD:

1 - Any factory installed options air resistance (larger gas heat section, economizer, wet coil, etc.).

2 - Any field installed accessories air resistance (duct resistance, diffuser, etc.).

See page 32 for blower motors and drives and page 32 for wet coil and options/accessory air resistance data.

**HORIZONTAL**

**KDB036H4T**

Air Volume cfm	External Static - in. w.g.															
	0.10		0.20		0.30		0.40		0.50		0.60		0.70		0.80	
	RPM	BHP	RPM	BHP	RPM	BHP	RPM	BHP	RPM	BHP	RPM	BHP	RPM	BHP	RPM	BHP
700	445	0.08	516	0.11	591	0.13	670	0.15	753	0.16	820	0.19	870	0.22	918	0.24
800	463	0.09	534	0.12	608	0.14	685	0.16	766	0.18	830	0.21	878	0.24	926	0.27
900	485	0.11	554	0.14	627	0.16	703	0.18	780	0.21	841	0.23	888	0.27	935	0.30
1000	509	0.13	578	0.16	649	0.19	722	0.21	796	0.23	854	0.26	900	0.29	947	0.33
1100	537	0.16	605	0.19	674	0.21	744	0.24	813	0.26	868	0.29	913	0.33	959	0.36
1200	567	0.19	633	0.22	700	0.24	768	0.27	833	0.30	884	0.33	928	0.37	974	0.40
1300	599	0.22	664	0.25	729	0.28	793	0.30	853	0.33	902	0.37	945	0.41	990	0.44
1400	634	0.26	697	0.29	758	0.31	819	0.34	875	0.38	921	0.42	964	0.46	1008	0.49
1500	669	0.30	730	0.33	789	0.36	846	0.39	897	0.42	941	0.47	983	0.51	1028	0.54

Air Volume cfm	External Static - in. w.g.															
	0.90		1.00		1.10		1.20		1.30		1.40		1.50		1.60	
	RPM	BHP	RPM	BHP	RPM	BHP	RPM	BHP	RPM	BHP	RPM	BHP	RPM	BHP	RPM	BHP
700	969	0.27	1021	0.29	1071	0.32	---	---	---	---	---	---	---	---	---	---
800	977	0.29	1030	0.32	1082	0.34	1128	0.37	1169	0.40	1205	0.42	---	---	---	---
900	986	0.32	1039	0.35	1090	0.37	1137	0.40	1177	0.43	1214	0.46	1248	0.49	1280	0.51
1000	997	0.35	1048	0.38	1098	0.41	114	0.44	1184	0.47	1221	0.50	1255	0.53	1287	0.56
1100	1008	0.39	1059	0.41	1107	0.44	1150	0.47	1191	0.51	1228	0.54	1263	0.57	1295	0.60
1200	1022	0.43	1071	0.45	1117	0.48	1160	0.52	1200	0.55	1237	0.59	1271	0.62	1303	0.66
1300	1037	0.47	1058	0.50	1130	0.53	1171	0.57	1210	0.60	1246	0.64	1280	0.68	1312	0.71
1400	1054	0.52	1100	0.54	1144	0.58	1183	0.62	1221	0.66	1256	0.70	1290	0.73	1321	0.77
1500	1073	0.57	1117	0.60	1159	0.64	1197	0.67	1234	0.71	1268	0.75	1301	0.79	1332	0.83

**BLOWER DATA**

**BELT DRIVE - 4 TON**

**BLOWER TABLE INCLUDES RESISTANCE FOR BASE UNIT ONLY WITH DRY INDOOR COIL AND AIR FILTERS IN PLACE.**

FOR ALL UNITS ADD:

1 - Any factory installed options air resistance (larger gas heat section, economizer, wet coil, etc.).

2 - Any field installed accessories air resistance (duct resistance, diffuser, etc.).

See page 32 for blower motors and drives and page 32 for wet coil and options/accessory air resistance data.

**DOWNFLOW**

**KDB048H4T**

Air Volume cfm	External Static - in. w.g.															
	0.10		0.20		0.30		0.40		0.50		0.60		0.70		0.80	
	RPM	BHP	RPM	BHP	RPM	BHP	RPM	BHP	RPM	BHP	RPM	BHP	RPM	BHP	RPM	BHP
900	466	0.10	525	0.14	586	0.17	646	0.20	729	0.20	821	0.19	899	0.20	953	0.23
1000	484	0.12	543	0.16	603	0.19	664	0.22	745	0.23	834	0.23	908	0.24	959	0.26
1100	505	0.15	563	0.18	622	0.22	682	0.25	762	0.26	847	0.26	917	0.27	966	0.30
1200	527	0.18	584	0.21	643	0.25	702	0.28	779	0.30	860	0.30	927	0.31	973	0.34
1300	550	0.21	607	0.25	664	0.29	722	0.32	797	0.33	875	0.34	937	0.35	981	0.38
1400	574	0.25	630	0.29	687	0.32	744	0.35	817	0.37	890	0.38	949	0.39	991	0.42
1500	603	0.28	659	0.32	714	0.36	770	0.39	839	0.41	907	0.42	962	0.44	1002	0.47
1600	651	0.29	703	0.33	754	0.37	806	0.41	867	0.43	927	0.45	976	0.48	1014	0.51
1700	708	0.30	754	0.34	800	0.38	846	0.42	898	0.46	949	0.49	992	0.53	1028	0.57
1800	764	0.31	804	0.36	844	0.40	884	0.45	927	0.49	970	0.54	1008	0.58	1044	0.63
1900	812	0.34	847	0.39	881	0.44	916	0.49	953	0.54	990	0.59	1025	0.64	1061	0.69
2000	857	0.42	889	0.47	920	0.52	952	0.57	986	0.62	1020	0.68	1055	0.73	1091	0.77

Air Volume cfm	External Static - in. w.g.															
	0.90		1.00		1.10		1.20		1.30		1.40		1.50		1.60	
	RPM	BHP	RPM	BHP	RPM	BHP	RPM	BHP	RPM	BHP	RPM	BHP	RPM	BHP	RPM	BHP
900	---	---	---	---	---	---	---	---	---	---	---	---	---	---	---	---
1000	996	0.31	1034	0.35	---	---	---	---	---	---	---	---	---	---	---	---
1100	1001	0.34	1040	0.38	1083	0.42	1128	0.46	1176	0.49	---	---	---	---	---	---
1200	1008	0.38	1047	0.42	1089	0.46	1133	0.49	1180	0.53	1224	0.56	1261	0.60	---	---
1300	1017	0.42	1055	0.46	1097	0.50	1139	0.53	1184	0.57	1228	0.60	1264	0.63	1295	0.67
1400	1026	0.46	1065	0.50	1106	0.54	1147	0.57	1191	0.61	1233	0.64	1269	0.68	1300	0.71
1500	1038	0.51	1076	0.55	1117	0.59	1157	0.62	1199	0.65	1240	0.69	1275	0.72	1305	0.76
1600	1050	0.56	1089	0.60	1129	0.64	1168	0.67	1209	0.71	1249	0.74	1282	0.78	1312	0.82
1700	1065	0.61	1103	0.65	1142	0.69	1181	0.73	1221	0.76	1259	0.80	1292	0.83	1320	0.88
1800	1081	0.67	1118	0.71	1156	0.75	1194	0.79	1234	0.82	1271	0.86	1302	0.90	1330	0.94
1900	1098	0.73	1135	0.77	1172	0.81	1209	0.85	1248	0.88	1284	0.92	1314	0.97	1341	1.01
2000	1128	0.82	1164	0.86	1201	0.89	1239	0.93	1276	0.97	1310	1.01	1336	1.06	1362	1.10

**BLOWER DATA**

**BELT DRIVE - 4 TON**

**BLOWER TABLE INCLUDES RESISTANCE FOR BASE UNIT ONLY WITH DRY INDOOR COIL AND AIR FILTERS IN PLACE.**

FOR ALL UNITS ADD:

1 - Any factory installed options air resistance (larger gas heat section, economizer, wet coil, etc.).

2 - Any field installed accessories air resistance (duct resistance, diffuser, etc.).

See page 32 for blower motors and drives and page 32 for wet coil and options/accessory air resistance data.

**HORIZONTAL**

**KDB048H4T**

Air Volume cfm	External Static - in. w.g.															
	0.10		0.20		0.30		0.40		0.50		0.60		0.70		0.80	
	RPM	BHP	RPM	BHP	RPM	BHP	RPM	BHP	RPM	BHP	RPM	BHP	RPM	BHP	RPM	BHP
900	464	0.10	514	0.13	576	0.15	644	0.17	728	0.18	817	0.19	893	0.21	951	0.24
1000	482	0.12	533	0.15	595	0.17	662	0.19	744	0.21	829	0.22	902	0.24	957	0.27
1100	504	0.14	556	0.17	617	0.20	683	0.22	762	0.24	843	0.25	912	0.28	965	0.31
1200	528	0.17	581	0.20	641	0.23	706	0.25	782	0.27	859	0.29	924	0.31	974	0.34
1300	556	0.21	609	0.24	669	0.26	731	0.29	804	0.31	877	0.33	938	0.35	985	0.38
1400	592	0.24	645	0.27	702	0.30	763	0.32	830	0.35	898	0.37	953	0.39	997	0.43
1500	641	0.26	692	0.29	746	0.33	801	0.36	862	0.38	921	0.41	970	0.44	1011	0.48
1600	696	0.28	743	0.32	792	0.35	842	0.39	894	0.42	945	0.45	988	0.49	1027	0.53
1700	750	0.31	792	0.35	836	0.39	880	0.43	924	0.47	968	0.51	1007	0.55	1043	0.59
1800	799	0.35	837	0.39	875	0.43	913	0.48	952	0.52	990	0.56	1026	0.61	1061	0.65
1900	840	0.40	873	0.45	907	0.49	941	0.54	976	0.58	1011	0.63	1045	0.67	1080	0.72
2000	883	0.48	913	0.53	944	0.57	976	0.62	1009	0.67	1043	0.71	1078	0.76	1112	0.8

Air Volume cfm	External Static - in. w.g.															
	0.90		1.00		1.10		1.20		1.30		1.40		1.50		1.60	
	RPM	BHP	RPM	BHP	RPM	BHP	RPM	BHP	RPM	BHP	RPM	BHP	RPM	BHP	RPM	BHP
900	995	0.28	1034	0.31	1077	0.35	1121	0.38	---	---	---	---	---	---	---	---
1000	999	0.31	1038	0.34	1081	0.38	1124	0.41	1168	0.44	1211	0.47	---	---	---	---
1100	1006	0.34	1044	0.38	1086	0.41	1129	0.44	1171	0.47	1213	0.50	1253	0.53	1293	0.56
1200	1014	0.38	1052	0.42	1093	0.45	1135	0.48	1176	0.51	1217	0.54	1257	0.58	1296	0.61
1300	1023	0.42	1061	0.46	1102	0.50	1143	0.53	1184	0.56	1224	0.59	1263	0.62	1302	0.66
1400	1035	0.47	1073	0.51	1112	0.54	1153	0.57	1193	0.61	1232	0.64	1271	0.67	1309	0.71
1500	1048	0.52	1086	0.56	1125	0.59	1164	0.63	1204	0.66	1243	0.69	1280	0.73	1317	0.77
1600	1063	0.57	1100	0.61	1139	0.65	1178	0.68	1216	0.71	1254	0.75	1291	0.79	1326	0.83
1700	1079	0.63	1116	0.67	1154	0.71	1192	0.74	1230	0.78	1267	0.81	1302	0.85	1337	0.89
1800	1097	0.69	1133	0.73	1171	0.77	1209	0.80	1246	0.84	1281	0.88	1315	0.92	1349	0.96
1900	1116	0.76	1152	0.80	1189	0.84	1226	0.87	1262	0.91	1296	0.95	1329	0.99	1361	1.03
2000	1148	0.84	1183	0.88	1220	0.92	1257	0.96	1291	1.00	1323	1.04	1354	1.08	1385	1.12

**BLOWER DATA**

**BELT DRIVE - 5 TON**

**BLOWER TABLE INCLUDES RESISTANCE FOR BASE UNIT ONLY WITH DRY INDOOR COIL AND AIR FILTERS IN PLACE.**

FOR ALL UNITS ADD:

1 - Any factory installed options air resistance (larger gas heat section, economizer, wet coil, etc.).

2 - Any field installed accessories air resistance (duct resistance, diffuser, etc.).

See page 32 for blower motors and drives and page 32 for wet coil and options/accessory air resistance data.

**DOWNFLOW**

**KDB060H4T**

Air Volume cfm	External Static - in. w.g.															
	0.10		0.20		0.30		0.40		0.50		0.60		0.70		0.80	
	RPM	BHP	RPM	BHP	RPM	BHP	RPM	BHP	RPM	BHP	RPM	BHP	RPM	BHP	RPM	BHP
1100	512	0.15	571	0.19	630	0.23	690	0.26	770	0.26	854	0.26	922	0.27	970	0.30
1200	535	0.18	593	0.22	651	0.26	710	0.30	788	0.30	868	0.30	933	0.31	978	0.34
1300	559	0.22	616	0.26	674	0.29	732	0.34	807	0.34	883	0.34	944	0.35	987	0.38
1400	584	0.26	641	0.29	698	0.33	755	0.37	827	0.37	899	0.38	956	0.40	997	0.43
1500	615	0.29	671	0.33	726	0.36	782	0.41	850	0.41	917	0.42	970	0.44	1009	0.47
1600	665	0.30	716	0.34	768	0.38	819	0.44	879	0.44	937	0.46	985	0.49	1022	0.52
1700	723	0.31	768	0.35	814	0.39	860	0.47	910	0.47	959	0.50	1001	0.54	1037	0.58
1800	779	0.32	818	0.37	857	0.41	897	0.50	939	0.50	980	0.55	1018	0.59	1054	0.64
1900	826	0.36	859	0.41	894	0.45	928	0.56	964	0.56	1000	0.61	1036	0.66	1072	0.70
2000	857	0.42	889	0.47	920	0.52	952	0.62	986	0.62	1020	0.68	1055	0.73	1091	0.77
2100	878	0.49	909	0.54	940	0.59	973	0.70	1006	0.70	1041	0.75	1076	0.80	1112	0.85
2200	897	0.55	929	0.61	961	0.66	994	0.78	1028	0.78	1063	0.83	1099	0.89	1134	0.93
2300	918	0.62	950	0.68	983	0.74	1017	0.86	1052	0.86	1087	0.92	1122	0.97	1157	1.02
2400	941	0.70	974	0.77	1008	0.83	1042	0.96	1077	0.96	1111	1.01	1146	1.06	1181	1.11

Air Volume cfm	External Static - in. w.g.															
	0.90		1.00		1.10		1.20		1.30		1.40		1.50		1.60	
	RPM	BHP	RPM	BHP	RPM	BHP	RPM	BHP	RPM	BHP	RPM	BHP	RPM	BHP	RPM	BHP
1100	1006	0.35	1045	0.39	1089	0.43	1134	0.46	---	---	---	---	---	---	---	---
1200	1013	0.38	1053	0.42	1095	0.46	1139	0.50	1186	0.53	1230	0.57	1266	0.60	---	---
1300	1022	0.42	1062	0.46	1104	0.50	1146	0.54	1192	0.57	1234	0.60	1269	0.64	1301	0.68
1400	1033	0.47	1072	0.51	1114	0.55	1155	0.58	1199	0.61	1240	0.65	1275	0.68	1305	0.72
1500	1045	0.52	1085	0.56	1125	0.60	1165	0.63	1208	0.66	1248	0.69	1281	0.73	1311	0.77
1600	1059	0.57	1098	0.61	1138	0.65	1177	0.68	1218	0.71	1257	0.75	1290	0.79	1319	0.83
1700	1074	0.62	1113	0.66	1152	0.70	1190	0.74	1231	0.77	1268	0.80	1299	0.84	1328	0.89
1800	1091	0.68	1129	0.72	1167	0.76	1205	0.80	1244	0.83	1280	0.87	1310	0.91	1338	0.95
1900	1109	0.75	1146	0.79	1183	0.82	1221	0.86	1260	0.90	1294	0.94	1323	0.98	1349	1.02
2000	1128	0.82	1164	0.86	1201	0.89	1239	0.93	1276	0.97	1310	1.01	1336	1.06	1362	1.10
2100	1148	0.89	1185	0.93	1221	0.97	1258	1.01	1294	1.05	1325	1.09	1351	1.14	1376	1.19
2200	1170	0.97	1206	1.01	1242	1.05	1277	1.09	1311	1.14	1341	1.18	1365	1.23	1390	1.28
2300	1193	1.06	1228	1.09	1262	1.14	1295	1.19	1327	1.24	1355	1.29	1380	1.33	1406	1.37
2400	1216	1.15	1250	1.19	1282	1.24	1313	1.30	1343	1.36	1371	1.40	1396	1.44	1423	1.48

**BLOWER DATA**

**BELT DRIVE - 5 TON**

**BLOWER TABLE INCLUDES RESISTANCE FOR BASE UNIT ONLY WITH DRY INDOOR COIL AND AIR FILTERS IN PLACE.**

FOR ALL UNITS ADD:

1 - Any factory installed options air resistance (larger gas heat section, economizer, wet coil, etc.).

2 - Any field installed accessories air resistance (duct resistance, diffuser, etc.).

See page 32 for blower motors and drives and page 32 for wet coil and options/accessory air resistance data.

**HORIZONTAL**

**KDB060H4T**

Air Volume cfm	External Static - in. w.g.															
	0.10		0.20		0.30		0.40		0.50		0.60		0.70		0.80	
	RPM	BHP	RPM	BHP	RPM	BHP	RPM	BHP	RPM	BHP	RPM	BHP	RPM	BHP	RPM	BHP
1100	509	0.15	562	0.18	624	0.20	691	0.22	771	0.24	852	0.25	919	0.28	970	0.31
1200	535	0.18	589	0.21	650	0.23	715	0.25	792	0.27	869	0.29	932	0.32	980	0.35
1300	564	0.21	618	0.24	678	0.27	741	0.29	815	0.31	887	0.33	946	0.36	991	0.39
1400	604	0.24	657	0.27	715	0.30	775	0.33	842	0.35	908	0.37	962	0.40	1004	0.43
1500	656	0.26	706	0.30	760	0.33	814	0.36	874	0.39	931	0.41	979	0.45	1019	0.48
1600	712	0.29	758	0.32	807	0.36	855	0.39	906	0.43	955	0.46	997	0.50	1035	0.54
1700	766	0.32	808	0.36	850	0.40	892	0.44	936	0.47	978	0.51	1016	0.56	1052	0.60
1800	814	0.36	851	0.40	888	0.44	925	0.49	963	0.53	1000	0.57	1035	0.62	1071	0.66
1900	853	0.41	886	0.46	919	0.50	952	0.55	986	0.60	1021	0.64	1056	0.69	1091	0.73
2000	883	0.48	913	0.53	944	0.57	976	0.62	1009	0.67	1043	0.71	1078	0.76	1112	0.80
2100	906	0.56	936	0.60	967	0.65	999	0.70	1033	0.75	1067	0.79	1101	0.84	1135	0.88
2200	930	0.64	960	0.68	991	0.73	1024	0.78	1058	0.83	1092	0.88	1126	0.92	1160	0.96
2300	954	0.72	985	0.77	1017	0.82	1051	0.87	1085	0.92	1119	0.96	1152	1.00	1186	1.04
2400	981	0.81	1013	0.86	1046	0.91	1079	0.96	1113	1.00	1180	1.05	1180	1.09	1213	1.13

Air Volume cfm	External Static - in. w.g.															
	0.90		1.00		1.10		1.20		1.30		1.40		1.50		1.60	
	RPM	BHP	RPM	BHP	RPM	BHP	RPM	BHP	RPM	BHP	RPM	BHP	RPM	BHP	RPM	BHP
1100	1010	35.00	1049	0.38	1091	0.42	1134	0.45	1176	0.78	1218	0.51	1258	0.54	1297	0.57
1200	1019	0.38	1058	0.42	1099	0.46	1141	0.49	1182	0.52	1223	0.55	1263	0.58	1302	0.61
1300	1030	0.43	1068	0.47	1108	0.50	1149	0.53	1190	0.56	1230	0.59	1270	0.63	1308	0.66
1400	1042	0.47	1080	0.51	1120	0.55	1160	0.58	1200	0.61	1240	0.65	1278	0.68	1315	0.72
1500	1056	0.53	1094	0.57	1133	0.60	1172	0.63	1212	0.67	250	0.70	1288	0.74	1324	0.77
1600	1071	0.58	1109	0.62	1147	0.66	1186	0.69	1225	0.72	1263	0.76	1299	0.80	1334	0.83
1700	1088	0.64	1126	0.68	1164	0.72	1202	0.75	1240	0.78	1276	0.82	1311	0.86	1345	0.90
1800	1107	0.70	1143	0.74	1181	0.78	1219	0.81	1256	0.85	1290	0.89	1324	0.93	1357	0.97
1900	1126	0.77	1163	0.81	1200	0.85	1237	0.88	1273	0.92	1306	0.96	1339	1.00	1371	1.04
2000	1148	0.84	1183	0.88	1220	0.92	1257	0.96	1291	1.00	1323	1.04	1354	1.08	1385	1.12
2100	1170	0.92	1206	0.96	1242	1.00	1277	1.04	1310	1.08	1340	1.13	1370	1.17	1401	1.21
2200	1195	1.00	1230	1.04	1265	1.08	1299	1.13	1330	1.18	1359	1.23	1388	1.27	1418	1.31
2300	1220	1.08	1254	1.13	1288	1.17	1320	1.23	1350	1.28	1378	1.34	1406	1.38	1435	1.42
2400	1245	1.18	1278	1.22	1311	1.28	1341	1.33	1370	1.40	1397	1.45	1425	1.50	1454	1.54

## BLOWER DATA

### BELT DRIVE KIT SPECIFICATIONS

Model No.	Motor HP		No. of Speeds	Drive Kits and RPM Range					
	Nominal	Maximum		A01	A02	A03	A05	A06	A07
036	0.75	0.86	2	low 449-673 high 673-1010	---	---	---	---	---
	1	1.15	2	---	---	---	low 598-897 high 897-1346	---	---
048	0.75	0.86	2	---	low 497-673 high 745-1117	---	---	---	---
	2	2.3	2	---	---	---	---	low 714-953 high 1071-1429	---
060	1	1.15	2			low 555-833 high 833-1250			
	2	2.3	2						low 808-1032 high 1212-1548

NOTE - Using total air volume and system static pressure requirements determine from blower performance tables rpm and motor hp required. Maximum usable hp of motors furnished are shown. In Canada, nominal motor hp is also maximum usable motor hp. If motors of comparable hp are used, be sure to keep within the service factor limitations outlined on the motor nameplate.

### OPTIONS / ACCESSORIES AIR RESISTANCE - in. w.g.

Air Volume cfm	Wet Indoor Coil		Gas Heat		Economizer	Filters	
	024 036, 048	060	Medium Input	High Input		MERV 8	MERV 13
800	0.01	0.01	0.02	0.02	0.04	0.04	0.05
1000	0.02	0.01	0.02	0.02	0.04	0.04	0.07
1200	0.02	0.01	0.02	0.02	0.04	0.04	0.07
1400	0.03	0.02	0.02	0.03	0.04	0.04	0.07
1600	0.04	0.03	0.03	0.04	0.04	0.04	0.07
1800	0.05	0.04	0.03	0.05	0.05	0.05	0.07
2000	0.06	0.05	0.04	0.06	0.05	0.05	0.08
2200	0.08	0.06	0.04	0.07	0.05	0.05	0.08
2400	0.09	0.07	0.05	0.08	0.05	0.05	0.08
2600	0.10	0.08	0.05	0.09	0.06	0.05	0.08
2800	0.11	0.09	0.06	0.10	0.06	0.05	0.08
3000	0.13	0.10	0.07	0.11	0.06	0.05	0.08

### CEILING DIFFUSERS AIR RESISTANCE (in. w.g.)

Air Volume cfm	RTD9-65S Step-Down Diffuser			FD9-65S Flush Diffuser
	2 Ends Open	1 Side & 2 Ends Open	All Ends & Sides Open	
800	0.15	0.13	0.11	0.11
1000	0.19	0.16	0.14	0.14
1200	0.25	0.20	0.17	0.17
1400	0.33	0.26	0.20	0.20
1600	0.43	0.32	0.20	0.24
1800	0.56	0.40	0.30	0.30
2000	0.73	0.50	0.36	0.36
2200	0.95	0.63	0.44	0.44

### CEILING DIFFUSER AIR THROW DATA

Air Volume - cfm Model No.	1 Effective Throw - ft.	
	RTD9-65S	FD9-65S
800	10 - 17	14 - 18
1000	10 - 17	15 - 20
1200	11 - 18	16 - 22
1400	12 - 19	17 - 24
1600	12 - 20	18 - 25
1800	13 - 21	20 - 28
2000	14 - 23	21 - 29
2200	16 - 25	22 - 30

### POWER EXHAUST FAN PERFORMANCE

Return Air System Static Pressure - in. w.g.	Air Volume Exhausted cfm
0.00	2000
0.05	1990
0.10	1924
0.15	1810
0.20	1664
0.25	1507
0.30	1350
0.35	1210

<sup>1</sup> Effective throw based on terminal velocities of 75 ft. per minute.



## ELECTRICAL DATA

## DIRECT DRIVE - 2 TON | 3 TON

Model No.		KDB024H	KDB036H			
<sup>1</sup> Voltage - 60hz		208/230V - 1 Ph	208/230V - 1 Ph	208/230V - 3 Ph	460V - 3 Ph	575V - 3 Ph
Compressor 1	Rated Load Amps	11.7	15.3	11.6	5.7	4
	Locked Rotor Amps	58.3	83	73	38	25.6
Outdoor Fan Motors (1)	Full Load Amps (total)	2.8	2.8	2.8	1.4	1.1
Power Exhaust (1) 0.33 HP	Full Load Amps (total)	2.4	2.4	2.4	1.3	1
Service Outlet 115V GFI (amps)		15	15	15	15	20
Indoor Blower Motor	Horsepower	0.33	0.50	0.50	0.50	0.50
	Type	Direct	Direct	Direct	Direct	Direct
	Full Load Amps	2.9	4.6	4.6	2.3	1.8
<sup>2</sup> Maximum Overcurrent Protection	Unit Only	30	40	30	15	15
	with (1) 0.33 HP Power Exhaust	---	40	35	15	15
<sup>3</sup> Minimum Circuit Ampacity	Unit Only	21	27	22	11	8
	with (1) 0.33 HP Power Exhaust	---	29	25	13	9

### ELECTRICAL ACCESSORIES

Disconnect	Standard Access	20W17	20W17	20W17	20W17	20W17
	Hinged Access	20W23	20W23	20W23	20W23	20W23

NOTE - All units have a minimum Short Circuit Current Rating (SCCR) of 5000 amps.

<sup>1</sup> Extremes of operating range are plus and minus 10% of line voltage.

<sup>2</sup> HACR type breaker or fuse.

<sup>3</sup> Refer to National or Canadian Electrical Code manual to determine wire, fuse and disconnect size requirements.

## ELECTRICAL DATA

## DIRECT DRIVE - 4 TON

Model No.		KDB048H			
<sup>1</sup> Voltage - 60hz		208/230V - 1 Ph	208/230V - 3 Ph	460V - 3 Ph	575V - 3 Ph
Compressor	Rated Load Amps	21.2	14	6.4	4.6
	Locked Rotor Amps	104	83.1	41	33
Outdoor Fan Motors (1)	Full Load Amps (total)	2.8	2.8	1.4	1.1
Power Exhaust (1) 0.33 HP	Full Load Amps (total)	2.4	2.4	1.3	1
Service Outlet 115V GFI (amps)		15	15	15	20
Indoor Blower Motor	Horsepower	0.75	0.75	0.75	0.75
	Type	Direct	Direct	Direct	Direct
	Full Load Amps	6.3	6.3	3.2	2.5
<sup>2</sup> Maximum Overcurrent Protection	Unit Only	50	40	15	15
	with (1) 0.33 HP Power Exhaust	50	40	20	15
<sup>3</sup> Minimum Circuit Ampacity	Unit Only	36	27	13	10
	with (1) 0.33 HP Power Exhaust	38	29	14	11

### ELECTRICAL ACCESSORIES

Disconnect	Standard Access	20W20	20W20	20W20	20W20
	Hinged Access	22A25	22A25	22A25	22A25

NOTE - All units have a minimum Short Circuit Current Rating (SCCR) of 5000 amps.

<sup>1</sup> Extremes of operating range are plus and minus 10% of line voltage.

<sup>2</sup> HACR type breaker or fuse.

<sup>3</sup> Refer to National or Canadian Electrical Code manual to determine wire, fuse and disconnect size requirements.

**ELECTRICAL DATA**
**DIRECT DRIVE - 5 TON**

Model No.		KDB060H			
<sup>1</sup> Voltage - 60hz		208/230V - 1 Ph	208/230V - 3 Ph	460V - 3 Ph	575V - 3 Ph
Compressor	Rated Load Amps	27.1	16.5	7.2	5.5
	Locked Rotor Amps	152.9	110	52	38.9
Outdoor Fan Motors (1)	Full Load Amps (total)	2.8	2.8	1.4	1.1
Power Exhaust (1) 0.33 HP	Full Load Amps (total)	2.4	2.4	1.3	1
Service Outlet 115V GFI (amps)		15	15	15	20
Indoor Blower Motor	Horsepower	1	1	1	1
	Type	Direct	Direct	Direct	Direct
	Full Load Amps	8.4	8.4	4.2	3.4
<sup>2</sup> Maximum Overcurrent Protection	Unit Only	70	45	20	15
	with (1) 0.33 HP Power Exhaust	70	45	20	15
<sup>3</sup> Minimum Circuit Ampacity	Unit Only	46	32	15	12
	with (1) 0.33 HP Power Exhaust	48	35	16	13

**ELECTRICAL ACCESSORIES**

Disconnect	Standard Access	20W20	20W20	20W20	20W20
	Hinged Access	22A25	22A25	22A25	22A25

NOTE - All units have a minimum Short Circuit Current Rating (SCCR) of 5000 amps.

<sup>1</sup> Extremes of operating range are plus and minus 10% of line voltage.

<sup>2</sup> HACR type breaker or fuse.

<sup>3</sup> Refer to National or Canadian Electrical Code manual to determine wire, fuse and disconnect size requirements.

**ELECTRICAL DATA**
**BELT DRIVE - 3 TON**

Model No.		KDB036H					
<sup>1</sup> Voltage - 60hz		208/230V - 3 Ph		460V - 3 Ph		575V - 3 Ph	
Compressor	Rated Load Amps	11.6		5.7		4	
	Locked Rotor Amps	73		38		25.6	
Outdoor Fan Motors (1)	Full Load Amps (total)	2.8		1.4		1.1	
Power Exhaust (1) 0.33 HP	Full Load Amps (total)	2.4		1.3		1	
Service Outlet 115V GFI (amps)		15		15		20	
Indoor Blower Motor	Horsepower	0.75	1	0.75	1	0.75	1
	Type	Belt	Belt	Belt	Belt	Belt	Belt
	Full Load Amps	3.5	4.6	1.6	2.1	1.3	1.7
<sup>2</sup> Maximum Overcurrent Protection	Unit Only	30	30	15	15	15	15
	with (1) 0.33 HP Power Exhaust	30	35	15	15	15	15
<sup>3</sup> Minimum Circuit Ampacity	Unit Only	21	22	11	11	8	8
	with (1) 0.33 HP Power Exhaust	24	25	12	12	9	9

**ELECTRICAL ACCESSORIES**

Disconnect	Standard Access	20W17	20W17	20W17	20W17
	Hinged Access	20W23	20W23	20W23	20W23

NOTE - All units have a minimum Short Circuit Current Rating (SCCR) of 5000 amps.

<sup>1</sup> Extremes of operating range are plus and minus 10% of line voltage.

<sup>2</sup> HACR type breaker or fuse.

<sup>3</sup> Refer to National or Canadian Electrical Code manual to determine wire, fuse and disconnect size requirements.

**ELECTRICAL DATA****BELT DRIVE - 4 TON**

<b>Model No.</b>		<b>KDB048H</b>					
<b><sup>1</sup> Voltage - 60hz</b>		<b>208/230V - 3 Ph</b>		<b>460V - 3 Ph</b>		<b>575V - 3 Ph</b>	
Compressor	Rated Load Amps	14		6.4		4.6	
	Locked Rotor Amps	83.1		41		33	
Outdoor Fan Motors (1)	Full Load Amps (total)	2.8		1.4		1.1	
Power Exhaust (1) 0.33 HP	Full Load Amps (total)	2.4		1.3		1	
Service Outlet 115V GFI (amps)		15		15		20	
Indoor Blower Motor	Horsepower	0.80	2	0.75	2	0.75	2
	Type	Belt	Belt	Belt	Belt	Belt	Belt
	Full Load Amps	3.5	7.5	1.6	3.4	1.3	2.7
<sup>2</sup> Maximum Overcurrent Protection	Unit Only	35	40	15	15	15	15
	with (1) 0.33 HP Power Exhaust	40	40	15	20	15	15
<sup>3</sup> Minimum Circuit Ampacity	Unit Only	24	28	11	13	9	10
	with (1) 0.33 HP Power Exhaust	27	31	13	15	10	11

**ELECTRICAL ACCESSORIES**

<b>Disconnect</b>	Standard Access	<b>20W20</b>	<b>20W20</b>	<b>20W20</b>	<b>20W20</b>
	Hinged Access	<b>22A25</b>	<b>22A25</b>	<b>22A25</b>	<b>22A25</b>

NOTE - All units have a minimum Short Circuit Current Rating (SCCR) of 5000 amps.

<sup>1</sup> Extremes of operating range are plus and minus 10% of line voltage.<sup>2</sup> HACR type breaker or fuse.<sup>3</sup> Refer to National or Canadian Electrical Code manual to determine wire, fuse and disconnect size requirements.**ELECTRICAL DATA****BELT DRIVE - 5 TON**

<b>Model No.</b>		<b>KDB060H</b>					
<b><sup>1</sup> Voltage - 60hz</b>		<b>208/230V - 3 Ph</b>		<b>460V - 3 Ph</b>		<b>575V - 3 Ph</b>	
Compressor	Rated Load Amps	16.5		7.2		5.5	
	Locked Rotor Amps	110		52		38.9	
Outdoor Fan Motors (1)	Full Load Amps (total)	2.8		1.4		1.1	
Power Exhaust (1) 0.33 HP	Full Load Amps (total)	2.4		1.3		1	
Service Outlet 115V GFI (amps)		15		15		20	
Indoor Blower Motor	Horsepower	1	2	1	2	1	2
	Type	Belt	Belt	Belt	Belt	Belt	Belt
	Full Load Amps	4.6	7.5	2.1	3.4	1.7	2.7
<sup>2</sup> Maximum Overcurrent Protection	Unit Only	40	45	15	20	15	15
	with (1) 0.33 HP Power Exhaust	45	45	20	20	15	15
<sup>3</sup> Minimum Circuit Ampacity	Unit Only	29	31	13	14	10	11
	with (1) 0.33 HP Power Exhaust	31	34	14	16	11	12

**ELECTRICAL ACCESSORIES**

<b>Disconnect</b>	Standard Access	<b>20W20</b>	<b>20W20</b>	<b>20W20</b>	<b>20W20</b>
	Hinged Access	<b>22A25</b>	<b>22A25</b>	<b>22A25</b>	<b>22A25</b>

NOTE - All units have a minimum Short Circuit Current Rating (SCCR) of 5000 amps.

<sup>1</sup> Extremes of operating range are plus and minus 10% of line voltage.<sup>2</sup> HACR type breaker or fuse.<sup>3</sup> Refer to National or Canadian Electrical Code manual to determine wire, fuse and disconnect size requirements.

## UNIT CLEARANCES

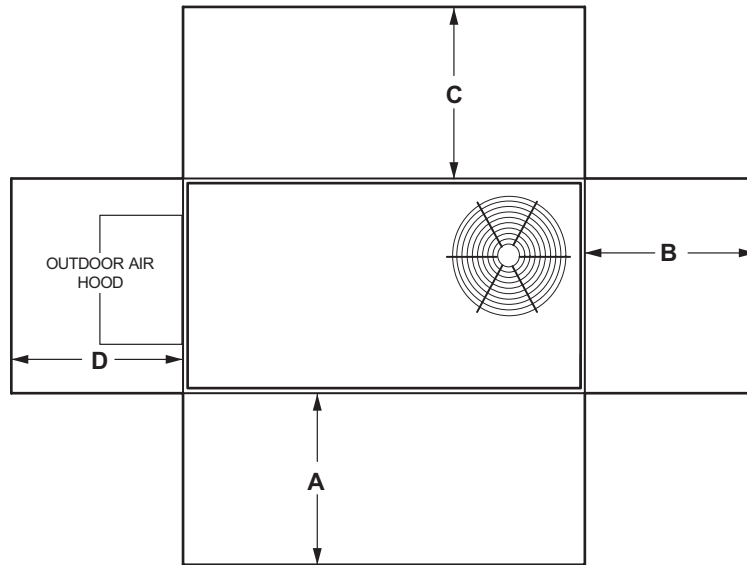

<sup>1</sup> Unit Clearance	A		B		C		D		Top Clearance
	in.	mm	in.	mm	in.	mm	in.	mm	
<b>Service Clearance</b>	36	914	36	914	36	914	36	914	<b>Unobstructed</b>
<b>Clearance to Combustibles</b>	36	914	1	25	1	25	1	25	
<b>Minimum Operation Clearance</b>	36	914	36	914	36	914	36	914	

NOTE - Entire perimeter of unit base requires support when elevated above the mounting surface.

<sup>1</sup> Service Clearance - Required for removal of serviceable parts.

Clearance to Combustibles - Required clearance to combustible material.

Minimum Operation Clearance - Required clearance for proper unit operation.

## OUTDOOR SOUND DATA

<sup>1</sup> Unit Model No.	Octave Band Sound Power Levels dBA, re 10 <sup>-12</sup> Watts - Center Frequency - Hz							<sup>1</sup> Sound Rating Number (dBA)
	125	250	500	1000	2000	4000	8000	
<b>KDB024</b>	62	67	70	70	64	57	51	74
<b>KDB036</b>	62	66	71	69	64	57	51	75
<b>KDB048</b>	67	68	73	72	68	63	53	77
<b>KDB060</b>	66	68	70	72	69	63	56	77

NOTE - The octave sound power data does not include tonal corrections.

<sup>1</sup> Sound Rating Number according to AHRI Standard 270-95 (includes pure tone penalty). Sound Rating Number is the overall A-Weighted Sound Power Level, (LWA), dBA (100 Hz to 10,000 Hz).

## WEIGHT DATA

Model Number	Net				Shipping			
	Base		Max.		Base		Max.	
	lbs.	kg	lbs.	kg	lbs.	kg	lbs.	kg
<b>KDB024</b>	595	270	665	302	635	288	705	320
<b>KDB036</b>	595	270	722	327	635	288	762	346
<b>KDB048</b>	670	304	808	366	710	322	848	385
<b>KDB060</b>	756	342	894	406	816	370	954	433

Base Unit - The unit with NO OPTIONS.

Max. Unit - The unit with ALL OPTIONS Installed (Economizer, etc.)

## OPTIONS / ACCESSORIES

	Shipping Weights		
	lbs.	kg	
<b>ECONOMIZER / OUTDOOR AIR / EXHAUST</b>			
<b>Economizer</b>			
Economizer - Includes Barometric Relief Dampers and Exhaust Hood	131	59	
<b>Outdoor Air Dampers</b>			
Motorized	40	18	
Manual	30	14	
<b>Power Exhaust</b>			
Standard Static	35	16	
<b>GAS HEAT</b>			
Medium Heat (adder over standard heat)	8	4	
High Heat (adder over standard heat)	19	9	
<b>ROOF CURBS</b>			
<b>Hybrid Roof Curbs, Downflow</b>			
8 in. height	50	23	
14 in. height	70	32	
18 in. height	80	36	
24 in. height	100	45	
<b>Hybrid Curbs, Full Perimeter, Downflow</b>			
8 in. height	57	26	
14 in. height	60	27	
18 in. height	91	41	
24 in. height	114	52	
<b>Adjustable Pitch Curb, Downflow</b>			
14 in. height	113	51	
<b>CEILING DIFFUSERS</b>			
Step-Down	RTD9-65S	80	36
	RTD11-95S	118	54
Flush	FD9-65S	80	36
	FD11-95S	118	54
Transitions (Supply and Return)	T1TRAN10AN1	22	10
	T1TRAN20N-1	21	10

# DIMENSIONS - UNIT

Model No.	CORNER WEIGHTS												CENTER OF GRAVITY											
	AA		BB		CC		DD		EE		FF		Base		Max.		Base		Max.					
	lbs.	kg	lbs.	kg	lbs.	kg	lbs.	kg	lbs.	kg	in.	mm	in.	mm	in.	mm	in.	mm	in.	mm				
<b>024</b>	124	56	153	69	154	70	158	72	175	79	179	81	141	64	174	79	38	965	42	1067	22	559	22	559
<b>036</b>	124	56	167	76	154	70	171	78	175	79	195	88	141	64	189	86	38	965	42	1067	22	559	22	559
<b>048</b>	140	64	186	84	174	79	192	87	198	90	218	99	159	72	212	96	38	965	42	1067	22	559	22	559
<b>060</b>	162	73	217	98	192	87	201	91	218	99	229	104	184	83	247	112	45	1143	51	1295	22	559	22	559

Base Unit - The unit with standard heat exchanger NO OPTIONS.  
 Max. Unit - The unit with ALL OPTIONS Installed (Economizer, etc.).

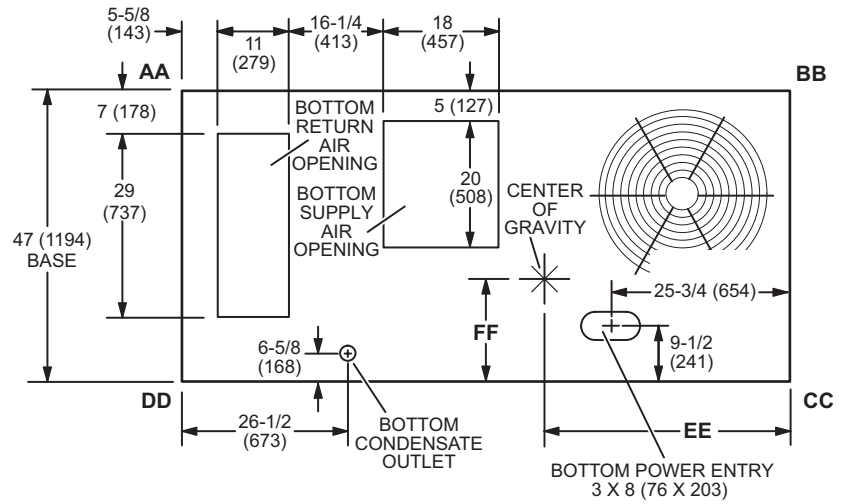

**TOP VIEW (Base)**

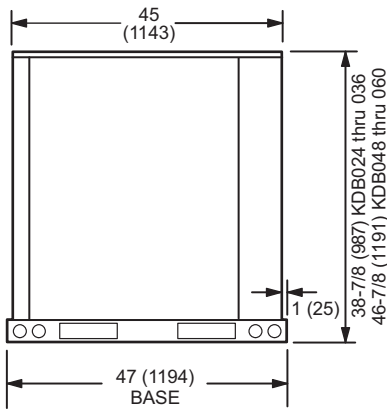

**END VIEW**

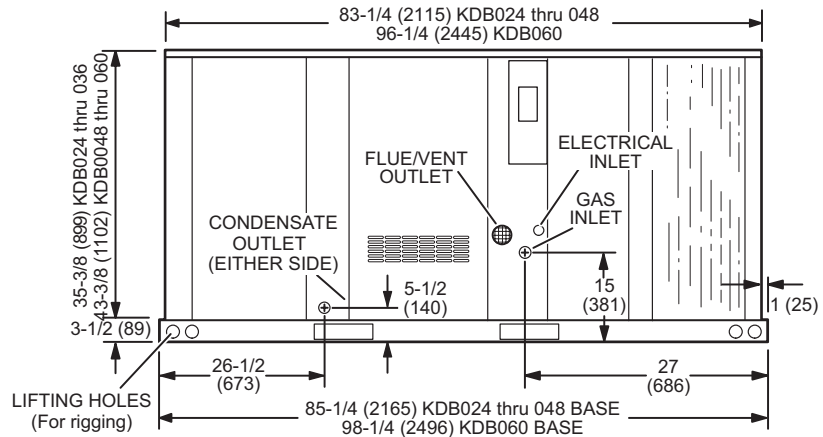

**SIDE VIEW**

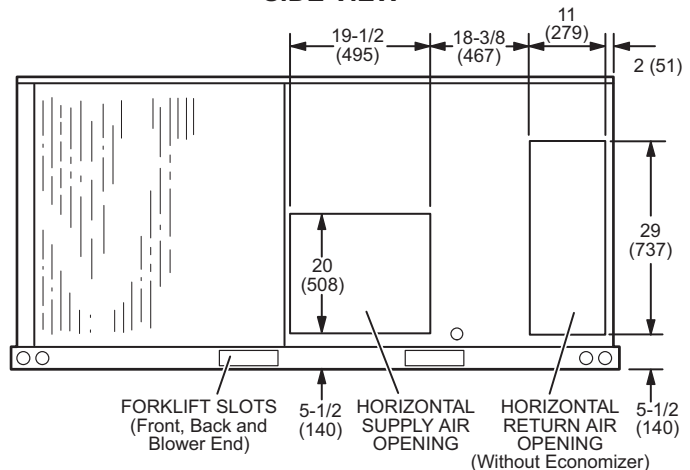

**BACK VIEW**

# DIMENSIONS - ACCESSORIES

## COMBINATION OUTDOOR AIR HOOD DETAIL FOR OPTIONAL ECONOMIZER AND BAROMETRIC RELIEF DAMPERS (Furnished With Economizer for Downflow Applications)

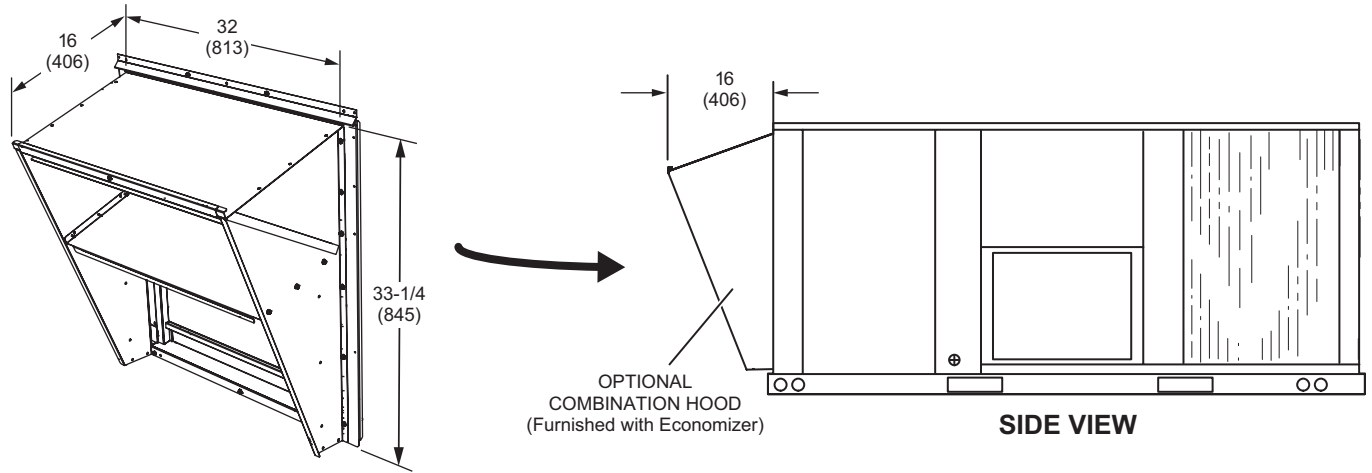

## OUTDOOR AIR DAMPER HOOD DETAIL (Downflow or Horizontal Applications)

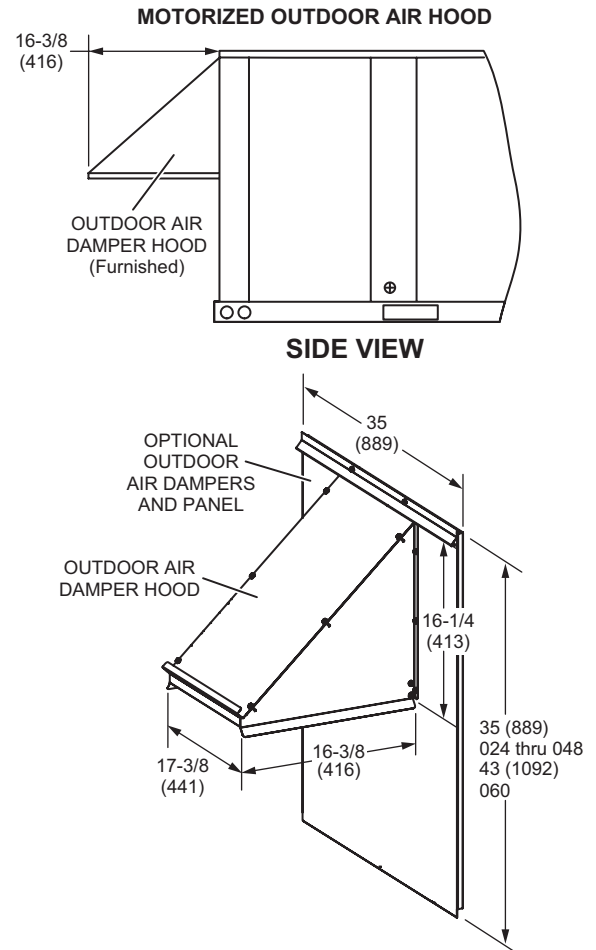
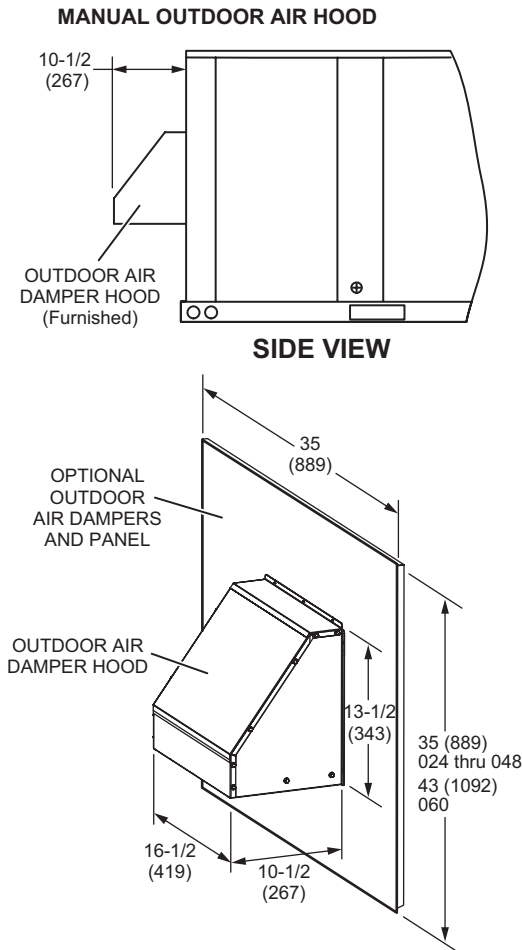

# DIMENSIONS - ACCESSORIES

## OUTDOOR AIR HOOD DETAIL WITH OPTIONAL ECONOMIZER AND OPTIONAL BAROMETRIC RELIEF DAMPERS WITH HOOD (Horizontal Application)

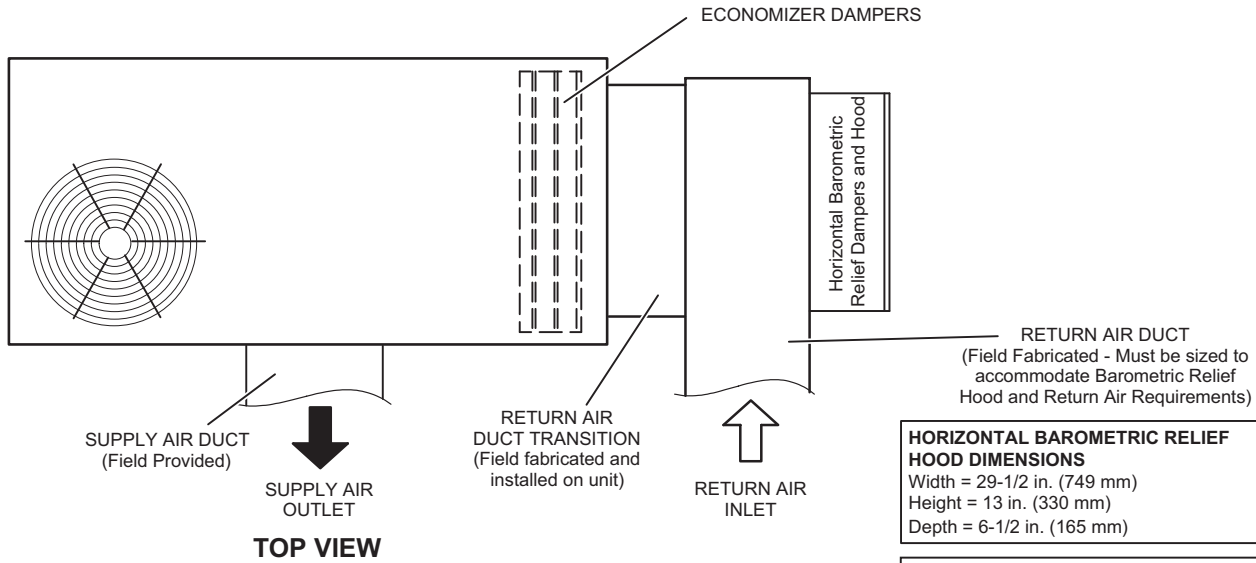

**HORIZONTAL BAROMETRIC RELIEF HOOD DIMENSIONS**  
 Width = 29-1/2 in. (749 mm)  
 Height = 13 in. (330 mm)  
 Depth = 6-1/2 in. (165 mm)

**NOTE -** Horizontal applications with Economizer require **Horizontal Economizer Conversion Kit**. See Options/Accessories table.

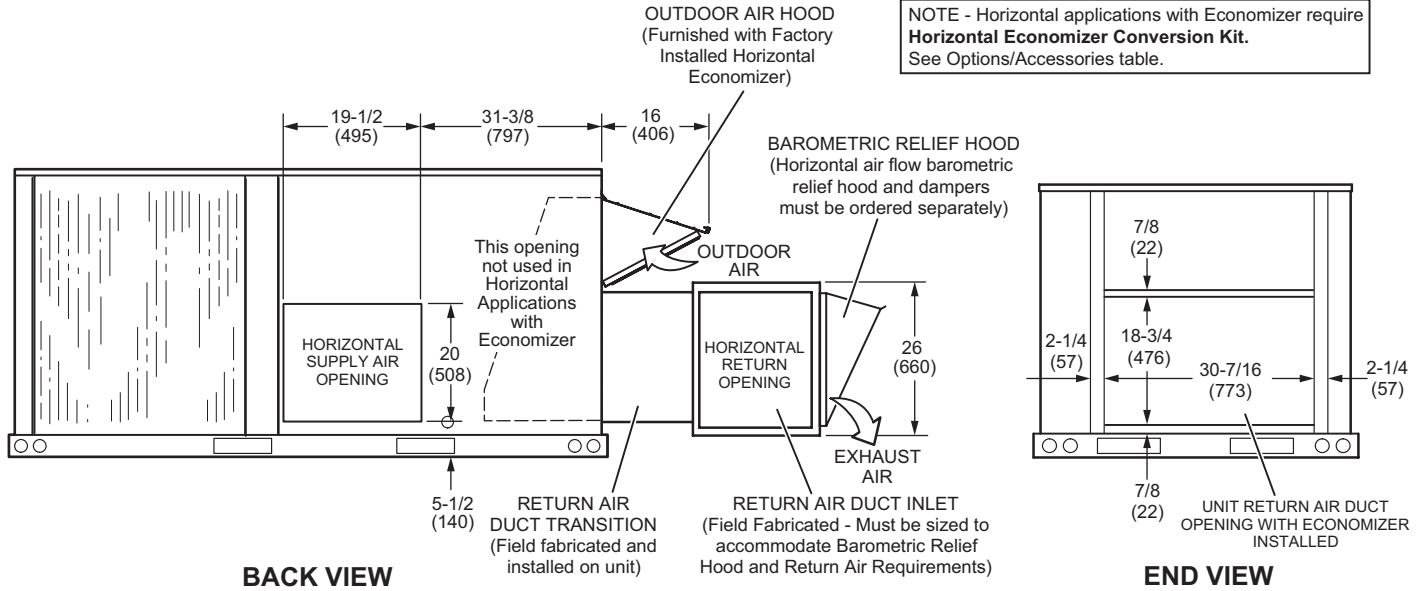

**NOTE -** Return Air Duct and Transition must be supported



# DIMENSIONS - ACCESSORIES

## HYBRID ROOF CURBS - DOUBLE DUCT OPENING - STANDARD AND FULL PERIMETER

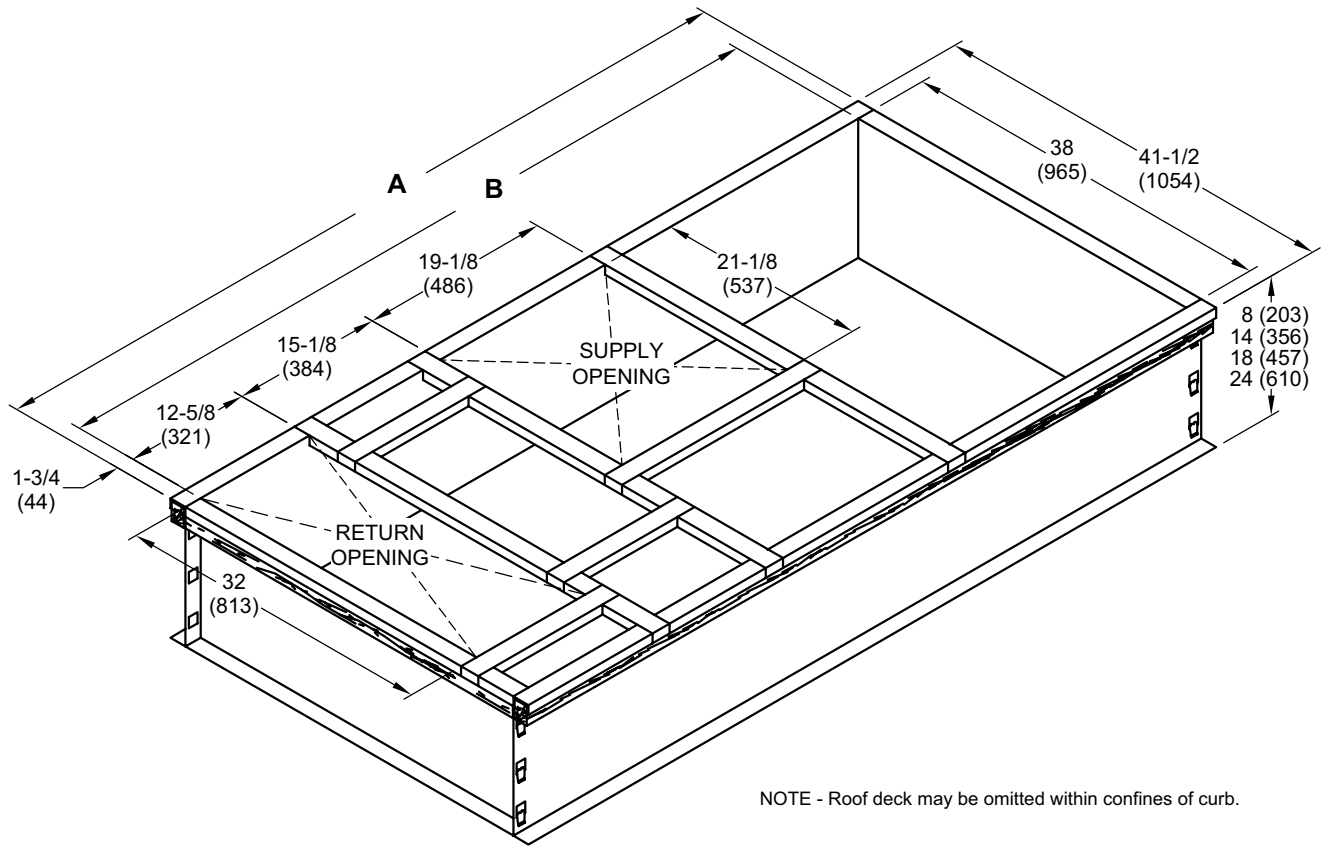

NOTE - Roof deck may be omitted within confines of curb.

### TYPICAL FLASHING DETAIL FOR ROOF CURB

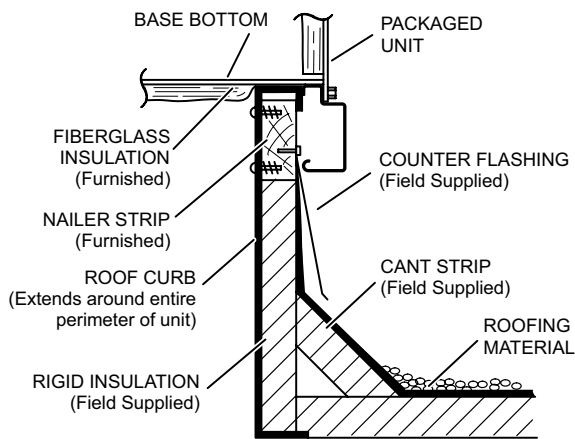

### DETAIL ROOF CURB

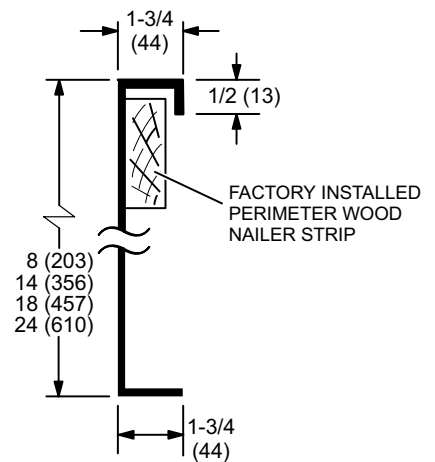

Model No.	A		B	
	in.	mm	in.	mm
Standard - 024, 036, 048, <sup>1</sup> 060	79-3/4	2026	76-1/4	1937
Full Perimeter - 060	92-3/4	2356	89-1/4	2267

<sup>1</sup> 060 models can be used on smaller 79-3/4 in. (2026 mm) roof curbs (not full perimeter) with 15-3/4 in. (400 mm) overhang at condenser end of unit. See dimension drawing on page 43

# DIMENSIONS - ACCESSORIES

## ADJUSTABLE PITCH CURBS - DOUBLE DUCT OPENING

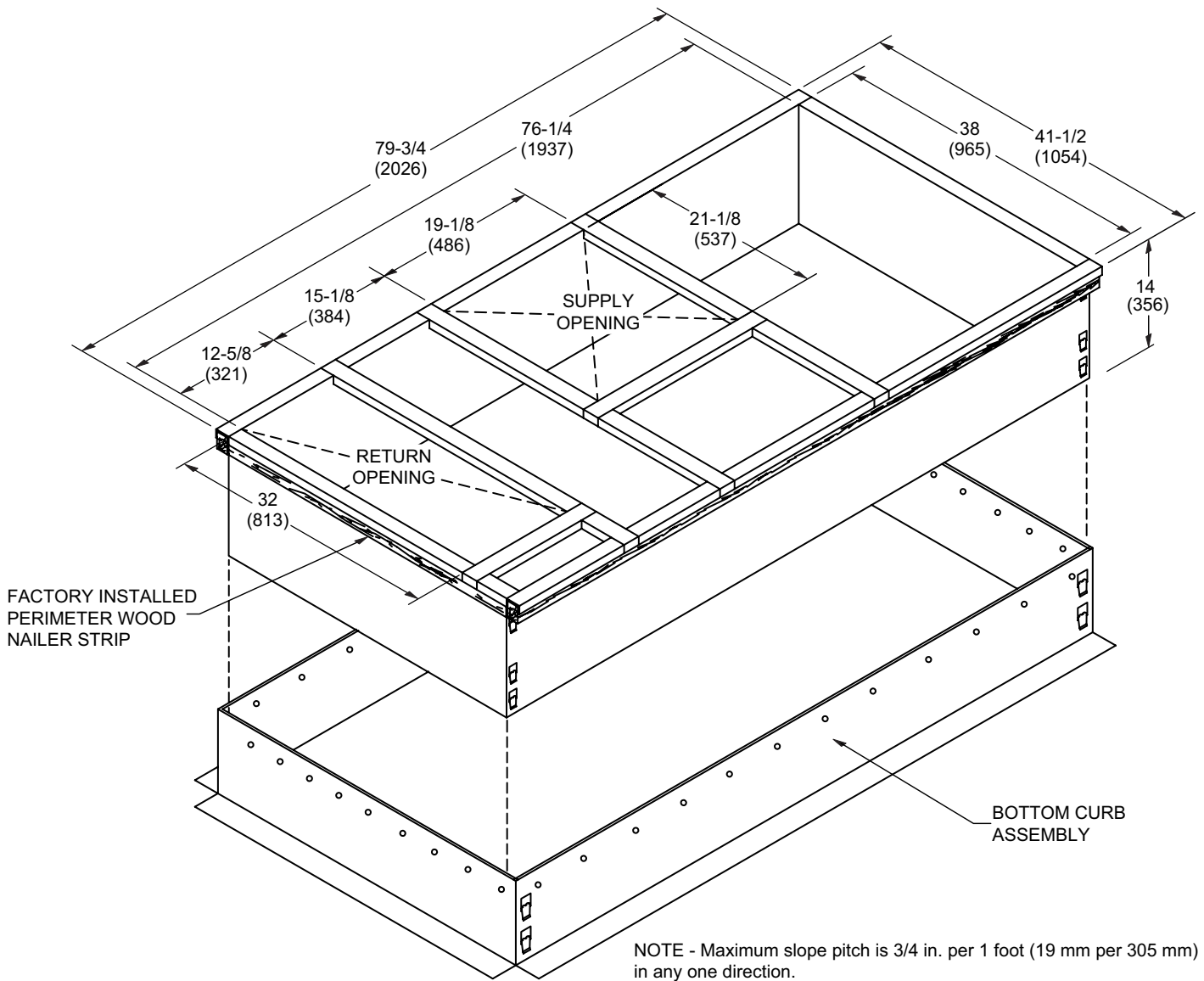

**TYPICAL FLASHING DETAIL FOR ROOF CURB**

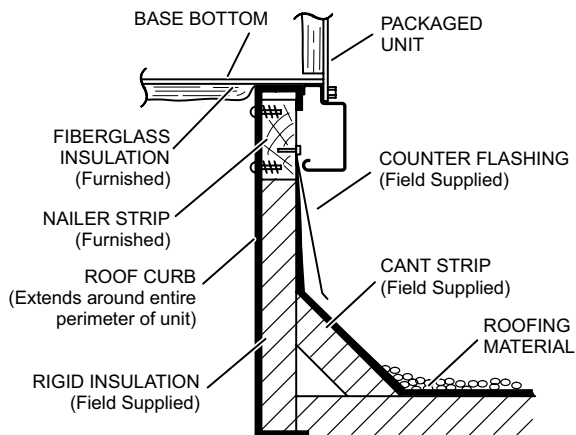

**DETAIL ROOF CURB**

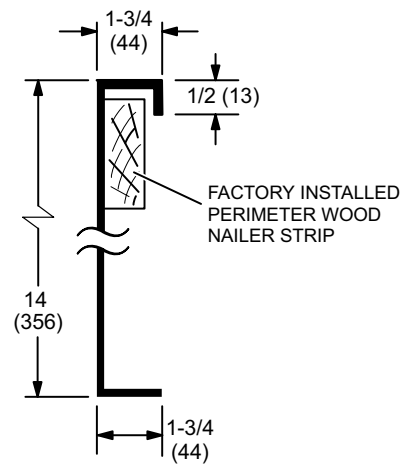

## DIMENSIONS - ACCESSORIES

060 MODELS - SHOWING OVERHANG ON SMALLER 79-3/4 INCH LENGTH ROOF CURBS  
(Not Full Perimeter)

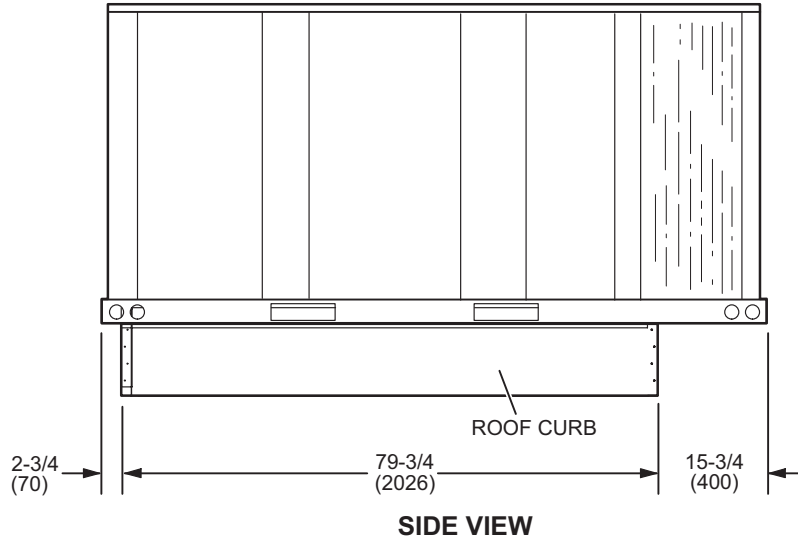

## TRANSITIONS

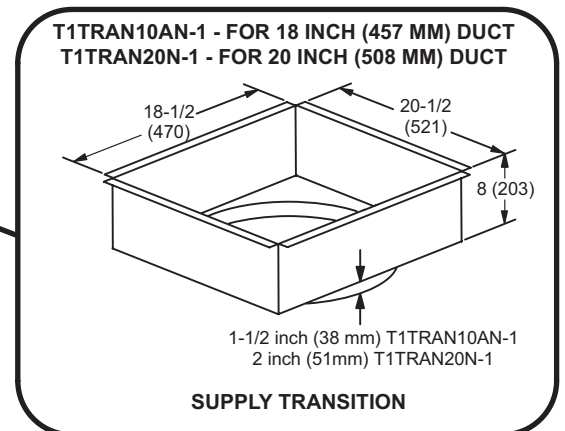
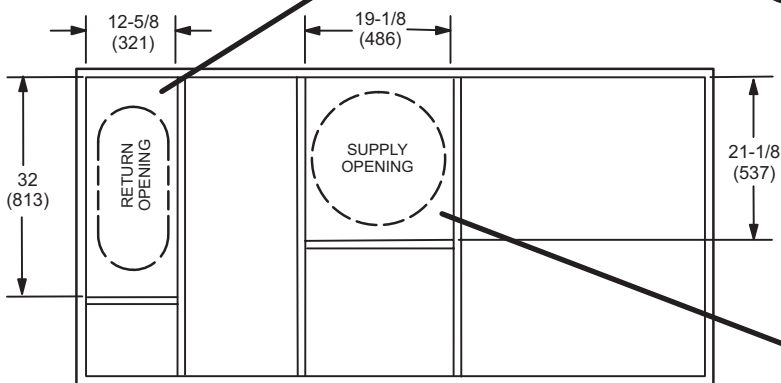
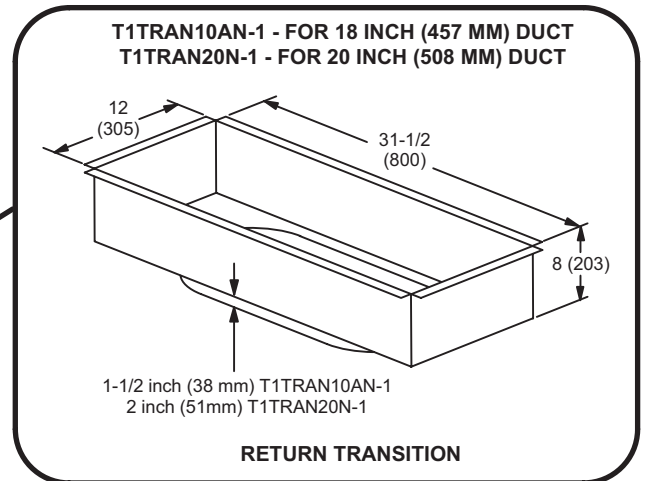

## DIMENSIONS - ACCESSORIES

### COMBINATION CEILING SUPPLY AND RETURN DIFFUSERS

#### STEP-DOWN CEILING DIFFUSER

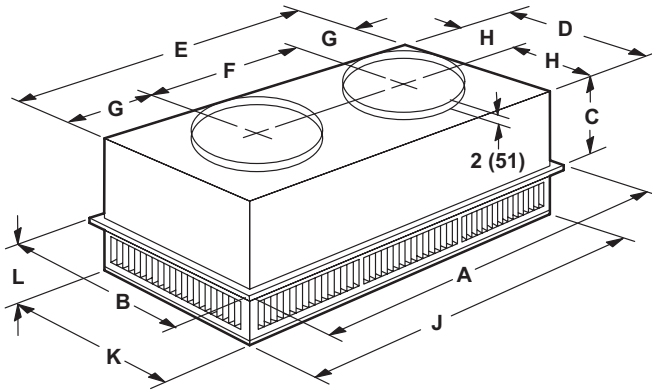

#### FLUSH CEILING DIFFUSER

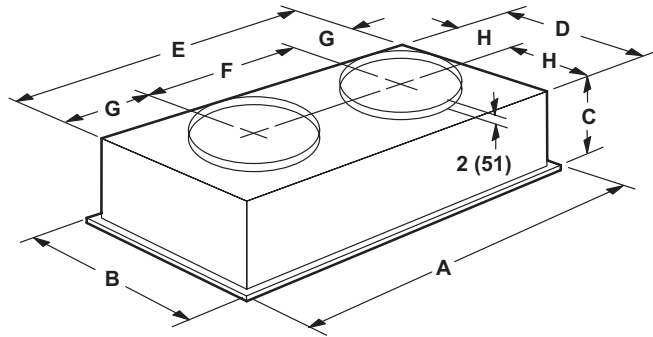

Model Number		RTD9-65S	RTD11-95S
A	in.	47-5/8	47-5/8
	mm	1159	1159
B	in.	23-5/8	29-5/8
	mm	600	752
C	in.	11-3/8	14-3/8
	mm	289	365
D	in.	21-1/2	27-1/2
	mm	546	699
E	in.	45-1/2	45-1/2
	mm	1156	1158
F	in.	22-1/2	22-1/2
	mm	572	572
G	in.	11-1/2	11-1/2
	mm	292	292
H	in.	10-3/4	13-3/4
	mm	273	349
J	in.	45-1/2	45-1/2
	mm	1156	1156
K	in.	21-1/2	27-1/2
	mm	546	699
L	in.	7-1/8	8-1/8
	mm	181	206
Duct Size	in.	18 round	20 round
	mm	457 round	508 round

Model Number		FD9-65S	FD11-95S
A	in.	47-5/8	47-5/8
	mm	1159	1159
B	in.	23-5/8	29-5/8
	mm	600	752
C	in.	13-1/2	16-5/8
	mm	343	422
D	in.	21	27
	mm	533	686
E	in.	45	45
	mm	1143	1143
F	in.	22-1/2	22-1/2
	mm	572	572
G	in.	11-1/4	11-1/4
	mm	286	286
H	in.	10-1/2	13-1/2
	mm	267	343
Duct Size	in.	18 round	20 round
	mm	457 round	508 round



## REVISIONS

Sections	Description of Change
Options/Accessories	<p>Added step-down transformers for UVC lights.</p> <p><b>Catalog numbers revised for:</b></p> <ul style="list-style-type: none"> <li>Barometric Relief Dampers</li> <li>Condensate Drain Trap</li> <li>Disconnects</li> <li>Economizers</li> <li>LPG Kits</li> <li>Power Exhaust</li> <li>Single Enthalpy</li> <li>Smoke Detectors</li> </ul>



Visit us at [www.Lennox.com](http://www.Lennox.com)

For the latest technical information, [www.LennoxCommercial.com](http://www.LennoxCommercial.com)

Contact us at 1-800-4-LENNOX

NOTE - Due to Lennox' ongoing commitment to quality, Specifications, Ratings and Dimensions subject to change without notice and without incurring liability. Improper installation, adjustment, alteration, service or maintenance can cause property damage or personal injury. Installation and service must be performed by a qualified installer and servicing agency.

©2021 Lennox Industries, Inc.