

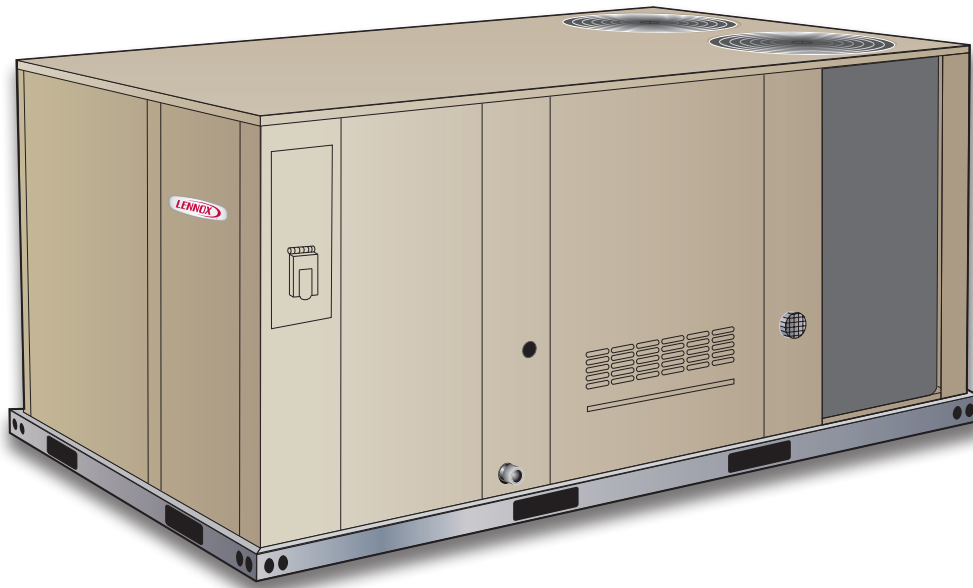

**COMMERCIAL  
PRODUCT SPECIFICATIONS**

Bulletin No. 210784  
June 2020  
Supersedes July 2019



**LANDMARK®**  
Performance Marked by Flexibility™



**ASHRAE 90.1  
COMPLIANT**

**7.5 to 10 Tons**  
**Net Cooling Capacity - 89,000 to 138,000 Btuh**  
**Net Heating Capacity - 86,000 to 138,000 Btuh**  
**Gas Input Heat Capacity - 130,000 to 240,000 Btuh**

**MODEL NUMBER IDENTIFICATION**

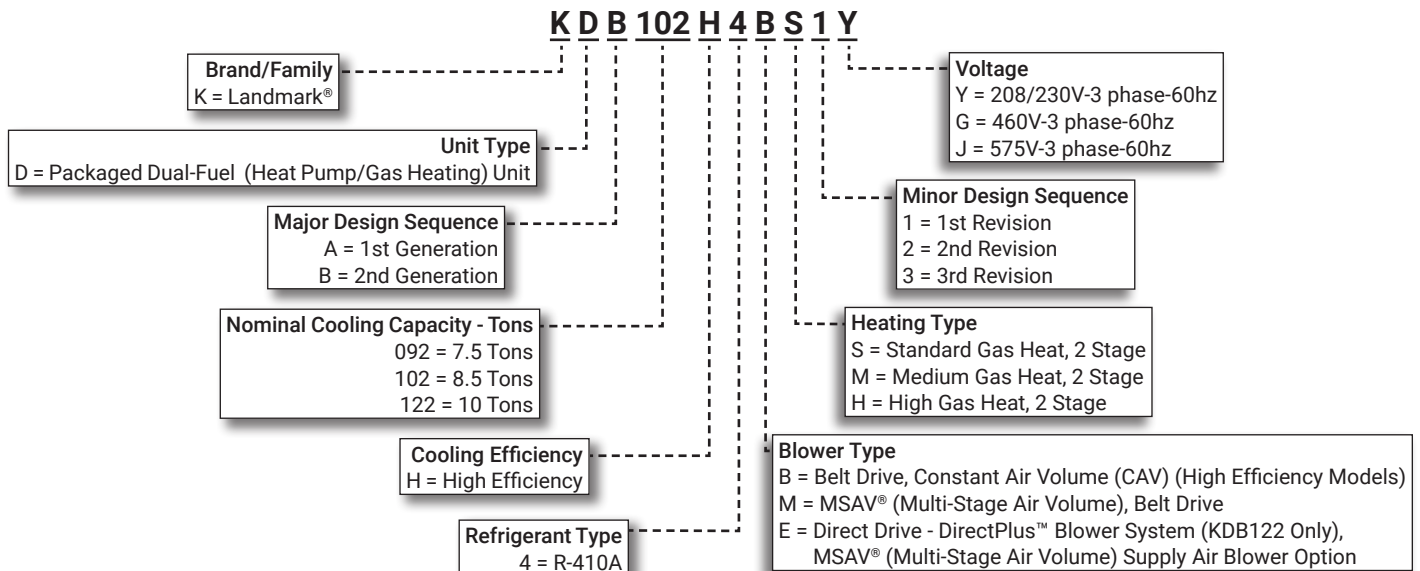

## FEATURE HIGHLIGHTS

Landmark® rooftop units from Lennox are the new standard for reliable, efficient rooftop units built for long-lasting performance that can significantly improve indoor environments.

1. Scroll Compressors
2. Copper Tube Coil Construction
3. Outdoor Coil Fans
4. Heat Exchanger/Inshot Burners
5. Heavy Gauge Steel Cabinet
6. Constant, Multi-Stage Air Volume (MSAV®) or DirectPlus™ Blower
7. Unit Control
8. Disconnect Switch (option)
9. Air Filters
10. Economizer (option)
11. Barometric Relief Dampers (option)

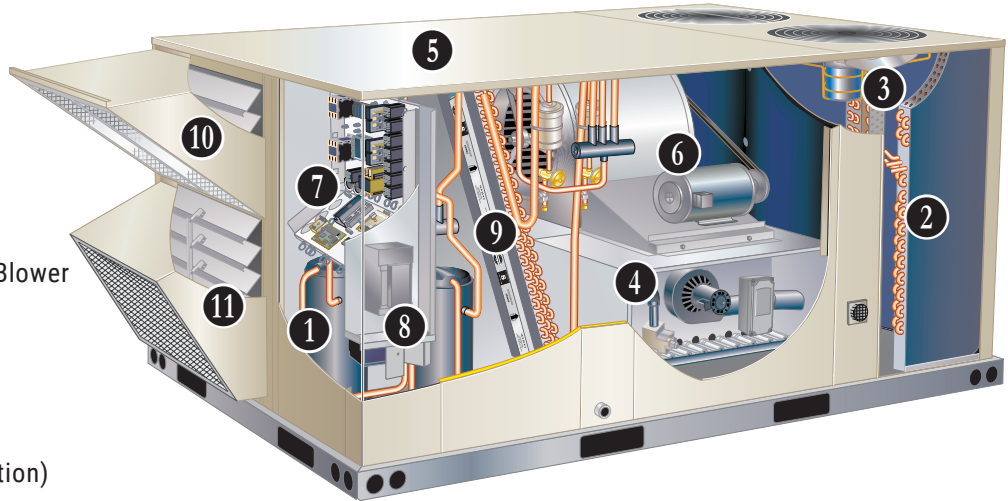

## CONTENTS

Approvals And Warranty . . . . .	3
Blower Data . . . . .	23
Cooling/Heating Ratings . . . . .	18
Dimensions - Accessories . . . . .	33
Dimensions - Unit . . . . .	31
Electrical Data . . . . .	27
Features And Benefits . . . . .	3
Model Number Identification . . . . .	1
Optional Conventional Temperature Control Systems . . . . .	12
Options / Accessories . . . . .	13
Outdoor Sound Data . . . . .	29
Specifications . . . . .	16
Specifications - Gas Heat . . . . .	17
Unit Clearances . . . . .	29
Weight Data . . . . .	30

## APPROVALS AND WARRANTY

### **APPROVALS**

- AHRI Standard 340/360 certified
- ETL and CSA listed
- CSA certified energy ratings
- Unit and components ETL, NEC and CEC bonded for grounding to meet safety standards for servicing
- All models are ASHRAE 90.1-2010 energy efficiency compliant and meet or exceed requirements of Section 6.8
- All models meet DOE 2018 energy efficiency standards
- MSAV models meet California Code of Regulations, Title 24 and ASHRAE 90.1-2010 Section 6.4.3.10 requirements for staged airflow
- ISO 9001 Registered Manufacturing Quality System

### **WARRANTY**

- Compressors - Limited five years
- Stainless Steel Heat Exchanger - Limited fifteen years
- High Performance Economizers (optional) - Limited five years
- All other covered components - Limited one year

## FEATURES AND BENEFITS

### **DUAL-FUEL OPERATION**

- In heating mode the heat pump operates the heat pump for 1st stage heating
- If 1st stage is not satisfied, the 2nd stage will activate gas heating (secondary heat source)
- Mechanical heat pump operation is automatically terminated on gas heat start-up
- Unit control automatically changes blower speeds between heat pump heating and gas heat operation
- Blower operates in high speed during 1st stage (heat pump) operation and is terminated during changeover to gas heat operation
- Blower starts up when heat exchanger is warm, and runs in high speed during 2nd stage (gas heat) operation
- If continuous blower operation is available on thermostat, change in blower speed automatically occurs during heat pump heat to gas heat changeover

### **COOLING/HEATING SYSTEM**

- Designed to maximize sensible and latent cooling performance at design conditions
- System can operate in the cooling mode from 30°F to 125°F without any additional controls

#### **R-410A Refrigerant**

- Non-chlorine based
- Ozone friendly

#### **1 Scroll Compressors**

- Scroll compressors on all models for high performance, reliability and quiet operation
- Resiliently mounted on rubber grommets for quiet operation

#### **Compressor Crankcase Heaters**

- Protects against refrigerant migration that can occur during low ambient operation

#### **Check/Thermal Expansion Valves**

- Assures optimal performance throughout the application range
- Removable element head

#### **Reversing Valves**

- 4-way interchange reversing valve effects a rapid change in direction of refrigerant flow resulting in quick changeover from cooling to heating and vice versa

#### **Filter/Driers**

- High capacity filter/drier protects the system from dirt and moisture

#### **High Pressure Switches**

- Protects the compressor from overload conditions such as dirty condenser coils, blocked refrigerant flow, or loss of outdoor fan operation
- Automatic reset

#### **Freezestats**

- Protects the evaporator coil from damaging ice build-up due to conditions such as low/no airflow, or low refrigerant charge

#### **2 Coil Construction**

- Copper tube construction
- Enhanced rippled-edge aluminum fins
- Flared shoulder tubing connections
- Silver soldered construction
- Factory leak tested

#### **Indoor Coil**

- Cross row circuiting
- Rifled copper tubing

#### **Condenser Coil**

- Two independent formed coils allow separation for cleaning

## FEATURES AND BENEFITS

### **COOLING SYSTEM (continued)**

#### **Condensate Drain Pan**

- Plastic pan, sloped to meet drainage requirements of ASHRAE 62.1
- Side or bottom drain connections
- Reversible to allow connection at back of unit

#### **Outdoor Coil Fan Motors**

- All models have variable speed (ECM) fan motors for energy efficient operation and quiet operation
- Thermal overload protected
- Totally enclosed
- Permanently lubricated ball bearings
- Shaft up
- Wire basket mount

### **3 Outdoor Coil Fans**

- PVC coated fan guard furnished

#### **Required Selections**

##### **Cooling Capacity**

- Specify nominal cooling capacity

#### **Options/Accessories**

##### **Field Installed**

###### **Condensate Drain Trap**

- Available in copper or PVC

###### **Drain Pan Overflow Switch**

- Monitors condensate level in drain pan
- Shuts down unit if drain becomes clogged

###### **Low Ambient Kit**

- Designed for use in ambient temperatures no lower than 0°F
- Cycles the outdoor fans while allowing compressor operation in the cooling cycle
- Includes field installed pressure switches on the liquid line to determine when to operate the outdoor fans
- Intermittent fan operation allows the system to operate without icing the evaporator coil and losing capacity.
- If the liquid line pressure drops below 240 psig outdoor fans operate at 25% normal fan speed
- If pressure drops below 180 psig all outdoor fans stop until pressure rises to 300 psig, then fans operate at 25% normal fan speed unless main pressure switches have reset to 450 psig to resume normal cooling operation and full fan speed operation

### **GAS HEATING SYSTEM**

- Aluminized steel inshot burners
- Direct spark ignition
- Electronic flame sensor
- Combustion air inducer
- Redundant automatic dual stage gas valve with manual shut-off

### **4 Heat Exchanger**

- Tubular construction, stainless steel
- Life cycle tested

#### **Electronic Pilot Ignition**

- Electronic spark igniter provides positive direct ignition of burners on each operating cycle
- Permits main gas valve to stay open only when the burners are proven to be lit
- If loss of flame occurs, gas valve closes, shutting off the gas to the burners
- LED indicates status and aids in troubleshooting
- Watchguard circuit on module automatically resets ignition controls after one hour of continuous thermostat demand after unit lockout, eliminating nuisance service calls
- Factory installed in the gas heating compartment

#### **Limit Control**

- Redundant limit controls with fixed temperature setting
- Protects heat exchanger and other components from overheating

#### **Safety Switches**

- Flame roll-out switch
- Flame sensor
- Combustion air inducer proving switch
- Protects system operation

#### **Required Selections**

##### **Gas Input Choice - Order one:**

- Standard Gas Heat, 2 Stage (84,500/130,000 Btuh)
- Medium Gas Heat, 2 Stage (117,000/180,000 Btuh)
- High Gas Heat, 2 Stage (156,000/240,000 Btuh)

#### **Options/Accessories**

##### **Field Installed**

###### **Bottom Gas Piping Kit**

- Allows bottom gas entry

###### **Combustion Air Intake Extensions**

- Recommended for use with existing flue extension kits in areas where high snow areas can block intake air

###### **Low Temperature Vestibule Heater**

- Electric heater automatically controls minimum temperature in gas burner compartment when temperature is below -40°F
- CSA certified to allow operation of unit down to -60°F

###### **LPG/Propane Kits**

- Conversion kit to field change over units from Natural Gas to LPG/Propane

## FEATURES AND BENEFITS

### GAS HEATING SYSTEM (continued)

#### Options/Accessories

##### Field Installed

##### Vertical Vent Extension Kit

- Use to exhaust flue gases vertically above unit
- Required when unit vent is too close to fresh air intakes per building codes
- Also prevents ice formation on intake louvers
- Kit contains vent transition, vent tee, drain cap and installation hardware

**NOTE** - Straight vent pipes (4 in. B-Vent) and caps are not furnished and must be field supplied. Refer to kit instructions for additional information.

### CABINET

#### 5 Construction

- Heavy-gauge steel panels
- Full perimeter heavy-gauge galvanized steel base rail
- Base rails have rigging holes
- Three sides of the base rail have forklift slots
- Raised edges around duct and power entry openings in the bottom of the unit for water protection

##### Airflow Choice

- Units are shipped in downflow (vertical) return air flow configuration

**NOTE** - Units can be field converted to horizontal airflow with optional Horizontal Discharge Kit.

##### Duct Flanges

- Provided for horizontal duct attachment

##### Power/Gas Entry

- Electrical and gas lines can be brought through the unit base or through horizontal access knock-outs

##### Exterior Panels

- Constructed of heavy-gauge, galvanized steel
- Two-layer enamel paint finish

##### Insulation

- Fully insulated with non-hygroscopic fiberglass insulation (conditioned areas)
- Unit base is fully insulated
- Base insulation serves as an air seal to the roof curb, eliminating the need to add a seal during installation

##### Access Panels

- Filter section
- Blower/heating section
- Compressor/controls section

#### Options/Accessories

##### Factory Installed

##### Corrosion Protection

- Completely flexible immersed coating
- Electrodeposited dry film process
- AST ElectroFin E-Coat
- Meets Mil Spec MIL-P-53084, ASTM B117 Standard Method Salt Spray Testing
- Indoor Corrosion Protection:
  - Coated coil
  - Painted blower housing
  - Painted base
- Outdoor Corrosion Protection:
  - Coated coil
  - Painted outdoor base

##### Hinged Access Panels

- Tool-less access
- Filter section
- Blower/heating section
- Compressor/controls section
- Panel seals and quarter-turn latching handles provide a tight air and water seal

##### Field Installed

##### Combination Coil/Hail Guards

- Heavy gauge steel frame
- Painted to match cabinet
- Expanded metal mesh protects outdoor coil

##### Horizontal Discharge Kit

- Consists of duct covers to block off downflow supply and return air openings for horizontal applications
- Also includes return air duct flanges for end return air when economizer is used in horizontal applications

**NOTE** - When configuring unit for horizontal application with economizer, a separate Horizontal Barometric Relief Damper with Hood must be ordered separately for installation in the return air duct.

##### Return Air Adaptor Plate

- For same size LC/LG/LH and TC/TG/TH unit replacement
- Installs on return air opening in unit to match return air opening on existing roof curbs
- Also see Accessory Air Resistance table

## FEATURES AND BENEFITS

### **BLOWER**

- A wide selection of supply air blower options are available to meet a variety of airflow requirements

#### **6 Belt Drive Blower System (All Models Except KDB122)**

- Overload protected
- Ball bearings
- Belt drive motors are offered on all models and are available in several different sizes to maximize air performance

#### **Supply Air Blower**

- Forward curved blades
- Double inlet
- Blower wheel statically and dynamically balanced
- Ball bearings
- Adjustable pulley (allows speed change)
- Blower assembly slides out of unit for servicing

#### **DirectPlus™ Blower System (KDB122 Models Only)**

- Variable-speed ECM (electronically commutated) motor
- Aerodynamically optimized impeller
- Backward curved blades
- Mounted directly onto the rotor
- Design combines the motor and electronics into one unit
- Eliminates the need for a variable-frequency drive
- Maintains the ability to ramp up or down the blower to meet comfort needs
- Blower assembly slides out of unit for servicing
- Air inlet grill reduces indoor sound levels without affecting air performance

#### **Required Selections**

#### **Select Belt Drive Constant Air Volume (CAV) or MSAV® (Multi-Stage Air Volume) Supply Air Blower Option (All Models except KDB122)**

- Order blower motor horsepower and drive kit number required when base unit is ordered
- See Drive Kit Specifications Table

#### **Select DirectPlus™**

- KDB122 Models Only

#### **CAV Operation**

- Supply air blower will provide a constant volume of air

#### **MSAV Operation**

- Units ordered with the MSAV option utilize a Variable Frequency Drive (VFD) to stage the supply air blower airflow
- The VFD alters the frequency and voltage of the power supply to the blower to control blower speed
- Supply air blower has two speeds:
  - Low speed for part-load cooling operation. Note - Low speed is 66% of high speed
  - High speed for full load cooling and all heat modes
- Full speed blower operation is set by adjusting the motor pulley to deliver the desired air volume
- The ventilation speed is selectable between high and low speed

**NOTE** - Part load airflow in cooling mode on MSAV units should not be set below 220 cfm/nominal full load ton to reduce the risk of evaporator coil freeze-up.

- The VFD has an operational range of -40 to 125° F outdoor air ambient temperature
- Lower operating costs are obtained when the blower is operated on lower speeds

#### **MSAV Sequence of Operation**

- Ventilation speed is determined by the VENT SPEED switch setting on fan control board (LO or HI)
- Blower operates in low speed for mechanical cooling (Y1)
- Blower operates in high speed for any other mode (free cooling, mechanical cooling Y1+Y2, and heating)
- Economizer damper minimum position is fully closed in unoccupied mode
- In occupied mode, the economizer damper minimum position is determined by the setting of the two potentiometers on fan control board:
  - LO SPD MIN POS potentiometer sets the minimum position when blower is operating at low speed
  - HI SPD MIN POS potentiometer sets the minimum position when blower is operating at high speed

#### **Options/Accessories**

##### **Field Installed**

##### **VFD Manual Bypass Kit**

- VFD Manual Bypass Control is available as a kit for units equipped with the MSAV option
- The VFD Manual Bypass Control is a manual bypass and is set by re-configuring the wiring on the unit

## FEATURES AND BENEFITS

### **CONTROLS**

- 7** **Unit Control**
- All control voltage is provided via a 24V (secondary) transformer with built-in circuit breaker protection
  - **Heat/Cool Staging** - Capable of up to 2 heat / 2 cool staging with a third party DDC control system or thermostat
  - **Low Voltage Terminal Block** - Provides screw terminal connections for thermostat or controller wiring
  - **Night Setback Mode** - Saves energy by closing outdoor air dampers and operating supply fan on thermostat demand only

#### **Defrost Control**

- Provides a defrost cycle, if needed, every 30 or 60 or 90 minutes (adjustable) of compressor on<sup>1</sup> time at outdoor coil temperature below 35°F
- Temperature switch mounted on outdoor coil liquid line terminates defrost cycle

**NOTE** - Gas heating operates during a defrost cycle.

#### **Fan Control (DirectPlus™ Blower System Only)**

- Provides variable speed control
- Blower speed can be independently set for both full load and part load applications
- Outdoor fan motor speed will vary depending on full or part load applications

#### **Balance Point Thermostat**

- Controls the changeover temperature between the heat pump heating operation and gas heat heating operation

### **Options/Accessories**

#### **Field Installed**

##### **Smoke Detector**

- Photoelectric type
- Installed in supply air section, return air section or both sections
- Available with power board and single sensor (supply or return) or power board and two sensors (supply and return)

#### **Commercial Control Systems**

##### **L Connection® Network**

- Complete building automation control system for single or multi-zone applications
- Options include local interface, software for local or remote communication, and hardware for networking other control functions
- See L Connection Network Product Specifications Bulletin for details

#### **Thermostats**

- Control system and thermostat options, see page 12

### **ELECTRICAL**

#### **Marked & Color-Coded Wiring**

- All electrical wiring is color-coded and marked to identify which components it is connecting

#### **Electrical Plugs**

- Positive connection electrical plugs are used to connect common accessories or maintenance parts for easy removal or installation

#### **Phase Monitor**

##### **(Factory Installed on Units Equipped with the MSAV® Supply Air Blower and DirectPlus™ Option)**

- Located in the control compartment
- Detects the phasing of incoming power
- If the incoming power is out of phase or if any of the three phases are lost, an indicator LED on the phase monitor will turn red and the unit will not start
- In normal operation with correct incoming power phasing, indicator LED will be green

### **Required Selections**

#### **Voltage Choice**

- Specify when ordering base unit

### **Options/Accessories**

#### **Factory or Field Installed**

##### **8** **Disconnect Switch**

- Accessible from outside of unit
- Spring loaded weatherproof cover
- Main power to the unit is field connected to the disconnect which allows all power to be shut off for service
- See Electrical Data tables for ordering information, page 27.

#### **GFI Service Outlets (2)**

- 115V ground fault circuit interrupter (GFCI) type
- Non-powered
- Field-wired

#### **Field Installed**

##### **GFI Weatherproof Cover**

- Single-gang cover
- Heavy-duty UV-resistant polycarbonate case construction
- Hinged base cover with gasket

## FEATURES AND BENEFITS

### INDOOR AIR QUALITY

- 9 Air Filters
- Disposable 2 inch filters furnished as standard

#### Options/Accessories

### Field Installed

#### Healthy Climate® High Efficiency Air Filters

- Disposable MERV 8 or MERV 13 (Minimum Efficiency Reporting Value based on ASHRAE 52.2) efficiency 2 inch pleated filters

#### Replacement Filter Media Kit With Frame

- Replaces existing pleated filter media. Includes washable metal mesh screen and metal frame with clip for holding replaceable non-pleated filter

#### Options/Accessories

### Field Installed

#### Healthy Climate® UVC Germicidal Lamps



- Germicidal lamps emit ultra-violet (UV-C) energy, which has been proven to be effective in reducing microbes such as viruses, bacteria, yeasts, and molds. This process either destroys the organism or controls its ability to reproduce.
- UV-C energy greatly reduces the growth and proliferation of mold and other bioaerosols (bacteria and viruses) on illuminated surfaces (particularly coil and drain pan)
- Lamps are field installed in the blower/evaporator coil section
- All necessary hardware for installation is included
- Lamps operate on 208/230V power supply. Step-down transformer must be field supplied when used with 460V and 575V rooftop units
- Magnetic safety interlock terminates power when access panels are removed
- Approved by ETL

#### Indoor Air Quality (CO<sub>2</sub>) Sensors

- Monitors CO<sub>2</sub> levels, reports to the Unit Controller which adjusts economizer dampers as needed



## OPTIONS / ACCESSORIES

### ECONOMIZER

#### Factory or Field Installed

#### 10 Economizer (Standard and High Performance Common Features)

- Downflow or Horizontal with Outdoor Air Hood and Barometric Relief Dampers with Exhaust Hood

- #### 11
- Barometric Relief Dampers allow relief of excess air
  - Aluminum blade dampers prevent blow back and outdoor air infiltration during off cycle
  - Bird screen furnished

**NOTE** - Optional Horizontal Low Profile Barometric Relief Dampers with Exhaust Hood are available for field installation in a reduced space.

- Occupied/Unoccupied mode with field furnished setback thermostat
- Demand Control Ventilation (DCV) ready using optional CO<sub>2</sub> sensors
- Mixed Air Sensor is furnished for field installation in the rooftop unit
- Sensor is factory installed when Economizers are factory installed
- Single sensible sensor is furnished with Economizer and enables economizer operation if the outdoor temperature is less than the setpoint of the control

#### Standard Economizer Features (Not for Title 24)

- Gear-driven action
- Return air and outdoor air dampers
- Plug-in connections to unit
- Nylon bearings
- Neoprene seals
- 24-volt
- Fully-modulating spring return motor

#### Standard Economizer Control Module

- The Standard Economizer Control Module can be adjusted to operate based on outdoor air temperatures



#### Economizer Controls:

- **Damper Minimum Position** - Can be set lower than traditional minimum air requirements resulting in cost savings
- **IAQ Sensor** - Signals dampers to modulate and maintain 55°F when CO<sub>2</sub> is higher than the CO<sub>2</sub> setpoint
- **Demand Control Ventilation (DCV) LED** - A steady green Demand Control Ventilation LED indicates the IAQ reading is higher than setpoint and requires more fresh air
- **Free Cool LED** - A steady green LED indicates outdoor air is suitable for free cooling
- Free Cooling runs when outdoor air temperature is lower than the set temperature on the economizer control

**NOTE:** The Free Cooling default setting for outdoor air temperature sensor is 55°F.

### ECONOMIZER (continued)

#### Factory or Field Installed

##### High Performance

##### Economizer Features

- Approved for California Title 24 building standards
- Low leakage dampers are Air Movement and Control Association International (AMCA) Class 1A Certified - Maximum 3 CFM per sq. ft. leakage at 1 in. w.g.
- ASHRAE 90.1-2010 compliant
- Gear-driven action
- High torque 24-volt fully-modulating spring return damper motor
- Return air and outdoor air dampers
- Plug-in connections to unit
- Stainless steel bearings
- Enhanced neoprene blade edge seals
- Flexible stainless steel jamb seals minimize air leakage

**NOTE** - High Performance Economizers are not approved for use with enthalpy controls in Title 24 applications.

**NOTE** - The Free Cooling setpoint for Title 24 applications must be set based on the Climate Zone where the system is installed. See Section 140.4 "Prescriptive Requirements for Space Conditioning Systems" of the California Energy Commission's 2013 Building Energy Efficiency Standards. Refer to Installation Instructions for complete setup information and menu parameters available.

##### High Performance

##### Economizer Control Module

- Module provides inputs and outputs to control economizer based on parameter settings
- Module automatically detects sensors by polling to determine which sensors are installed in system
- Module displays any alarm messages (fault detection and diagnostics) as an aid in troubleshooting
- Non-volatile memory retains parameter settings in case of power failure
- Keypad with four navigation buttons and LCD screen is furnished for setting economizer parameters
  - Menu Up/Exit (⬆) button returns to the main menu
  - Arrow Up (▲) button moves to the previous or next parameter within the selected menu
  - Arrow Down (▼) button moves to the next parameter within the selected menu
  - Select (enter) (↵) button confirms parameter selection



##### **Main Menu Structure:**

- STATUS (economizer and system operation status)
- SETPOINTS (settings for various setpoint parameters)
- SYSTEM SETUP (settings/information about the system)
- ADVANCED SETUP (freeze protection, CO<sub>2</sub> settings, stage 3 delay and additional calibration settings)
- CHECKOUT (damper positions)
- ALARMS (output signal that can be configured for remote alarm monitoring)

**NOTE** - Refer to Installation Instructions for complete setup information and menu parameters available.

#### Factory or Field Installed

##### Single Enthalpy Temperature Control (Not for Title 24)

- Outdoor air enthalpy sensor enables Economizer if the outdoor enthalpy is less than the setpoint of the control

##### Field Installed

##### Differential Enthalpy Control (Not for Title 24)

- Order two Single Enthalpy Controls
- One is field installed in the return air section, the other in the outdoor air section
- Allows the economizer control board to select between outdoor air or return air, whichever has lower enthalpy

## OPTIONS / ACCESSORIES

### EXHAUST

#### Field Installed

##### **Horizontal Low Profile Barometric Relief Dampers**

- Replaces barometric relief dampers furnished with Economizer
- For use when unit is configured for horizontal applications in a reduced space requiring an economizer
- Allows relief of excess air
- Aluminum blade dampers prevent blow back and outdoor air infiltration during off cycle
- Field installed in return air duct
- Exhaust hood with bird screen furnished

**NOTE** - Requires Horizontal Discharge Kit

##### **Power Exhaust Fan**

- Installs internal to unit for downflow applications only with economizer option
- Provides exhaust air pressure relief
- Interlocked to run when supply air blower is operating,
- Fan runs when outdoor air dampers are 50% open (adjustable)
- Motor is overload protected
- Fan is 20 in. diameter
- Five blades
- One 1/3 hp motor

**NOTE** - Requires Economizer and Downflow Barometric Relief Dampers.

### OUTDOOR AIR

#### Factory or Field Installed

##### **Outdoor Air Damper**

- Downflow or Horizontal
- Linked mechanical dampers
- 0 to 25% (fixed) outdoor air adjustable
- Installs in unit
- Includes outdoor air hood
- Automatic model features fully modulating spring return damper motor with plug-in connection
- Manual model features parallel blade, gear-driven dampers with adjustable fixed position

**NOTE** - Maximum mixed air temperature in cooling mode: 100°F.

### ROOF CURBS

#### Field Installed

- Nail strip furnished (downflow only)
- Mates to unit
- US National Roofing Contractors Approved
- Shipped knocked down

##### **Hybrid Roof Curbs, Downflow**

- Interlocking tabs fasten corners together
- No tools required
- Can also be fastened together with furnished hardware
- Available in 8, 14, 18, and 24 inch heights

##### **Adjustable Pitch Curb**

- Fully adjustable pitch curbs (3/4 in. per foot in any direction) provide a level platform for rooftop units allowing flexible installations on roofs with uneven or sloped angles
- Uses interlocking tabs to fasten corners together. No tools required
- Hardware is furnished to connect upper curb with lower curb
- Available in 14 inch height

##### **Adaptor Curbs (not shown)**

- Curbs are regionally sourced
- Dimensions vary based upon the source

**NOTE** - Contact your local sales representative for a detailed cut sheet with applicable dimensions.

### CEILING DIFFUSERS

#### Field Installed

##### **Ceiling Diffusers (Flush or Step-Down)**

- White powder coat finish on diffuser face and grilles
- Insulated UL listed duct liner
- Diffuser box has collars for duct connection
- Step-down diffusers have double deflection blades
- Flush diffusers have fixed blades
- Provisions for suspending
- Internally sealed to prevent recirculation
- Removable return air grille
- Adapts to T-bar ceiling grids or plaster ceilings

##### **Transitions (Supply and Return)**

- Used with diffusers
- Installs in roof curb
- Galvanized steel construction
- Flanges furnished for duct connection to diffusers
- Fully insulated

## OPTIONAL CONVENTIONAL TEMPERATURE CONTROL SYSTEMS

### ComfortSense® 7500 Commercial 7-Day Programmable Thermostat



- Four-Stage Heating / Two-Stage Cooling
- Universal Multi-Stage
- Intuitive Touchscreen Interface
- Automatic Changeover between Heating and Cooling
- Full Seven-Day Programming
- Four Time Periods Per Day
- Temperature and Humidity Control
- One-Touch Away Mode
- Holiday Scheduling
- Smooth Setback Recovery (SSR)
- Performance Reports
- Notifications/Reminders
- Dehumidification Control for Split Systems and Rooftop Units
- Economizer Relay Control
- Backlit Display
- Wallplate Furnished
- FDD, ASHRAE and IECC Compliant

### ComfortSense® 3000 Commercial 5-2 Day Programmable Thermostat

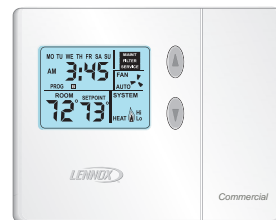

- Two-Stage Heating / Two-Stage Cooling
- Conventional Systems
- Intuitive Interface
- 5-2 Day Programming
- Program Hold
- Remote Indoor Temperature Sensing
- Smooth Setback Recovery (SSR)
- Economizer Relay Control
- Maintenance/Filter/Service Reminders
- Backlit Display
- Wallplate Furnished
- Simple Up and Down Temperature Control

### Bacnet Compatible Thermostat With Reheat Function



- 7-Day Programmable
- For units with or without Humiditrol®
- BTL listed MS/TP ensures compatibility with any BACnet system
- Built-in control programs for conventional and heat pump applications
- Conventional systems up to 3-stage heat and 3-stage cool
- Heat pumps with 1 or 2 compressors and up to 2-stage auxiliary heat
- On-board temperature and humidity sensor
- Multiple configurable inputs and outputs enable advanced control strategies
- Set-up Wizard enables rapid system configuration
- No special tools required for installation or commissioning
- Seven-day (2, 4 or 6 event) occupancy scheduling per day
- Backlit 5-inch LCD touchscreen

Description	Model No.	Catalog No.
<b>ComfortSense® 7500 7-Day Programmable</b>	C0STAT06FF2L	<b>17G74</b>
Universal thermostat locking guard (clear)	C0MISC15AE1-	<b>39P21</b>
<b>Temperature Sensors</b>	<sup>1</sup> Remote non-adjustable wall-mount 20k	<b>47W36</b>
	<sup>1</sup> Remote non-adjustable wall-mount 10k	<b>47W37</b>
	Remote non-adjustable discharge air (duct mount)	<b>19L22</b>
	Outdoor temperature sensor	<b>X2658</b>
<sup>1</sup> Remote wall-mount sensors can be applied in any of the following combinations: One Sensor - (1) 47W36, Two Sensors - (2) 47W37, Three Sensors - (2) 47W36 and (1) 47W37 Four Sensors - (4) 47W36, Five Sensors - (3) 47W36 and (2) 47W37		
<b>ComfortSense® 3000 5-2 Day Programmable</b>	C0STAT05FF1L	<b>11Y05</b>
Thermostat wall mounting plate	C0MISC17AE1-	<b>X2659</b>
<b>Temperature Sensor</b>	Remote non-adjustable wall mount 10k averaging	<b>47W37</b>
<b>BACnet Controls</b>	<sup>2</sup> 7-Day BACnet Thermostat	<b>Y8241</b>
	<sup>3</sup> BACnet Module (factory or field)	<b>16X71</b>
<b>BACnet Room Sensors</b>	With Display	<b>97W23</b>
	Without Display	<b>97W24</b>
<b>BACnet Accessories</b>	Plenum Cable (RJ45/CAT5 75 ft.)	<b>97W25</b>

<sup>2</sup> BACnet Thermostat (Y8241) will control units with and without the Humiditrol® option. If there is a mix of units equipped with and without Humiditrol on the same site, this thermostat can be used for all units if suitable.

<sup>3</sup> Not compatible with units equipped with Humiditrol® option.

<sup>4</sup> Only compatible with BACnet Module (16X71).

## OPTIONS / ACCESSORIES

Item Description	Model Number	Catalog Number	Unit Model No		
			KDB 092	KDB 102	KDB 122
<b>COOLING/HEATING SYSTEM</b>					
Condensate Drain Trap	PVC - C1TRAP20AD2	<b>76W26</b>	X	X	X
	Copper - C1TRAP10AD2	<b>76W27</b>	X	X	X
Corrosion Protection		Factory	O	O	O
Drain Pan Overflow Switch	K1SNSR71AB1-	<b>74W42</b>	X	X	X
Efficiency		High	O	O	O
Low Ambient Kit	K1SNSR34*B0	<b>14N31</b>	X	X	X
Refrigerant Type		R-410A	O	O	O
<b>GAS HEATING SYSTEM</b>					
Bottom Gas Piping Kit	C1GPKT01B-01	<b>54W95</b>	X	X	X
Combustion Air Intake Extensions	T1EXTN10AN1	<b>19W51</b>	X	X	X
Gas Heat Input	130,000 Btuh	Factory	O	O	O
	180,000 Btuh	Factory	O	O	O
	240,000 Btuh	Factory	O	O	O
Low Temperature Vestibule Heater	208/230V-3ph - C1LTVH10B-2Y	<b>13X63</b>	X	X	X
	460V - C1LTVH10B-2G	<b>13X64</b>	X	X	X
	575V - C1LTVH10B-2J	<b>13X65</b>	X	X	X
LPG/Propane Conversion Kits	Standard Heat - C1PROP23BS1	<b>14N22</b>	X	X	X
	Medium Heat - C1PROP22BS1	<b>14N23</b>	X	X	X
	High Heat - C1PROP21BS1	<b>14N25</b>	X	X	X
Vertical Vent Extension	C1EXTN2021	<b>42W16</b>	X	X	X
<b>BLOWER - SUPPLY AIR</b>					
Blower Option	CAV (Constant Air Volume)	Factory	O	O	
	MSAV® (Multi-Stage Air Volume)	Factory	O	O	
	DirectPlus™ (Direct Drive) MSAV® (Multi-Stage Air Volume)	Factory			O
Blower Motors	Belt Drive - 2 hp	Factory	O	O	
	Belt Drive - 3 hp	Factory	O	O	
	Belt Drive - 5 hp	Factory	O	O	
VFD Manual Bypass Kit (for MSAV equipped units only)	KVFDB12C-1	<b>90W53</b>	X	X	
Drive Kits	Kit #1 590-890 rpm	Factory	O	O	
See Blower Data Tables for selection	Kit #2 800-1105 rpm	Factory	O	O	
	Kit #3 795-1195 rpm	Factory	O	O	
	Kit #4 730-970 rpm	Factory	O	O	
	Kit #5 940-1200 rpm	Factory	O	O	
	Kit #6 1015-1300 rpm	Factory	O	O	
	Kit #10 900-1135 rpm	Factory	O	O	
	Kit #11 1040-1315 rpm	Factory	O	O	
	Kit #12 1125-1425 rpm	Factory	O	O	

NOTE - Catalog and model numbers shown are for ordering field installed accessories.

OX - Configure To Order (Factory Installed) or Field Installed

O = Configure To Order (Factory Installed)

X = Field Installed

## OPTIONS / ACCESSORIES

Item Description	Model Number	Catalog Number	Unit Model No		
			KDB 092	KDB 102	KDB 122
<b>CABINET</b>					
Combination Coil/Hail Guards	High Efficiency - K1GARD53B-1	14Y77	X	X	
	High Efficiency - E1GARD51BP1	13T06			X
Hinged Access Panels		Factory	O	O	O
Horizontal Discharge Kit	K1HECK00B-1	51W25	X	X	X
Return Air Adaptor Plate (for LC/LG/LH and TC/TG/TH unit replacement)	C1CONV10B-1	54W96	X	X	X

## CONTROLS

**NOTE - Also see Conventional Thermostat Control Systems on page 12 for Additional Options.**

Commercial Controls	L Connection® Building Automation System	- - -	X	X	X
Smoke Detector - Supply or Return (Power board and one sensor)	C1SNSR44B-2	11K76	X	X	X
Smoke Detector - Supply and Return (Power board and two sensors)	C1SNSR43B-2	11K80	X	X	X

## INDOOR AIR QUALITY

Healthy Climate® High Efficiency Air Filters 20 x 25 x 2 (Order 4 per unit)	MERV 8 - C1FLTR15B-1	50W61	X	X	X
	MERV 13 - C1FLTR40B-1	52W41	X	X	X
Replacement Media Filter With Metal Mesh Frame (includes non-pleated filter media)	C1FLTR30B-1-	Y3063	X	X	X

## Indoor Air Quality (CO<sub>2</sub>) Sensors

Sensor - Wall-mount, off-white plastic cover with LCD display	C0SNSR50AE1L	77N39	X	X	X
Sensor - Wall-mount, off-white plastic cover, no display	C0SNSR52AE1L	87N53	X	X	X
Sensor - Black plastic case with LCD display, rated for plenum mounting	C0SNSR51AE1L	87N52	X	X	X
Sensor - Wall-mount, black plastic case, no display, rated for plenum mounting	C0MISC19AE1	87N54	X	X	X
CO <sub>2</sub> Sensor Duct Mounting Kit - for downflow applications	C0MISC19AE1-	85L43	X	X	X
Aspiration Box - for duct mounting non-plenum rated CO <sub>2</sub> sensors (87N53 or 77N39)	C0MISC16AE1-	90N43	X	X	X

## UVC Germicidal Lamps

<sup>1</sup> Healthy Climate® UVC Light Kit (208/230v-1ph)	C1UVCL10B-1	54W62	X	X	X
--	-------------	-------	---	---	---

## ELECTRICAL

Voltage 60 hz	208/230V - 3 phase	Factory	O	O	O
	460V - 3 phase	Factory	O	O	O
	575V - 3 phase	Factory	O	O	O
Disconnect Switch	80 amp - C1DISC080B-1	54W56	OX	OX	OX
GFI Service Outlets	15 amp non-powered, field-wired (208/230V, 460V only)	LTAGFIK10/15	74M70	OX	OX
	20 amp non-powered, field-wired (575V only)	C1GFIC120FF1	67E01	X	X
Weatherproof Cover for GFI	C1GFIC199FF1	10C89	X	X	X

NOTE - Catalog and model numbers shown are for ordering field installed accessories.

OX - Configure To Order (Factory Installed) or Field Installed

O = Configure To Order (Factory Installed)

X = Field Installed

## OPTIONS / ACCESSORIES

Item Description	Model Number	Catalog Number	Unit Model No		
			KDB 092	KDB 102	KDB 122
<b>ECONOMIZER</b>					
<b>Standard Economizer (Not for Title 24)</b>					
Standard Economizer with Single Temperature Control Downflow or Horizontal Applications - Includes Barometric Relief Dampers and Air Hoods	K1ECON20B-2	13U45	OX	OX	OX
<b>Standard Economizer Controls (Not for Title 24)</b>					
Single Enthalpy Control	C1SNSR64FF1	53W64	OX	OX	OX
Differential Enthalpy Control (order 2)	C1SNSR64FF1	53W64	X	X	X
<b>High Performance Economizer (Approved for California Title 24 Building Standards / AMCA Class 1A Certified)</b>					
High Performance Economizer with Single Temperature Control Downflow or Horizontal Applications - Includes Barometric Relief Dampers and Air Hoods	K1ECON22B-3	17U09	OX	OX	OX
<b>High Performance Economizer Controls (Not for Title 24)</b>					
Single Enthalpy Control	C1SNSR60FF1	10Z75	OX	OX	OX
Differential Enthalpy Control (order 2)	C1SNSR60FF1	10Z75	X	X	X
<b>Horizontal Low Profile Barometric Relief Dampers With Exhaust Hood</b>					
Horizontal Low Profile Barometric Relief Dampers With Exhaust Hood	LAGEDH03/15	53K04	X	X	X
<b>OUTDOOR AIR</b>					
<b>Outdoor Air Dampers with Outdoor Air Hood</b>					
Motorized	C1DAMP20B-1	14G28	OX	OX	OX
Manual	C1DAMP10B-2	14G29	OX	OX	OX
<b>POWER EXHAUST</b>					
Standard Static	208/230V-3ph - K1PWRE10B-1Y	53W44	X	X	X
	460V-3ph - K1PWRE10B-1G	53W45	X	X	X
	575V-3ph - K1PWRE10B-1J	53W46	X	X	X
<b>ROOF CURBS</b>					
<b>Hybrid Roof Curbs, Downflow</b>					
8 in. height	C1CURB70B-1	11F54	X	X	X
14 in. height	C1CURB71B-1	11F55	X	X	X
18 in. height	C1CURB72B-1	11F56	X	X	X
24 in. height	C1CURB73B-1	11F57	X	X	X
<b>Adjustable Pitch Curb, Downflow</b>					
14 in. height	C1CURB55B-1	54W50	X	X	X
<b>CEILING DIFFUSERS</b>					
Step-Down - Order one	RTD11-95S	13K61	X		
	RTD11-135S	13K62		X	X
Flush - Order one	FD11-95S	13K56	X		
	FD11-135S	13K57		X	X
Transitions (Supply and Return) - Order one	C1DIFF30B-1	12X65	X		
	C1DIFF31B-1	12X66		X	X

NOTE - Catalog and model numbers shown are for ordering field installed accessories.

OX - Configure To Order (Factory Installed) or Field Installed

O = Configure To Order (Factory Installed)

X = Field Installed

## SPECIFICATIONS

General Data		Nominal Tonnage	7.5 Ton	7.5 Ton	8.5 Ton	8.5 Ton	10 Ton
		Model Number	KDB092H4B	KDB092H4M	KDB102H4B	KDB102H4M	KDB122H4E
		Efficiency Type	High	High	High	High	High
		Blower Type	CAV (Constant Air Volume)	MSAV® (Multi-Stage Air Volume)	CAV (Constant Air Volume)	MSAV® (Multi-Stage Air Volume)	MSAV (Multi-Stage Air Volume) DirectPlus™ (Direct Drive)
<b>Cooling Performance</b>	Gross Cooling Capacity - Btuh		91,600	91,600	103,400	103,400	121,000
	<sup>1</sup> Net Cooling Capacity - Btuh		89,000	89,000	100,000	100,000	118,000
	AHRI Rated Air Flow - cfm		3,000	3,000	3,400	3,400	3600
	Total Unit Power - kW		7.3	7.3	8.3	8.3	9.6
	<sup>1</sup> EER (Btuh/Watt)		12.1	12.1	12.0	12.0	12.3
	<sup>1</sup> IEER (Btuh/Watt)		12.9	14.2	12.5	14.3	14.8
	Refrigerant Type		R-410A	R-410A	R-410A	R-410A	R-410A
Refrigerant Charge	Circuit 1	13 lbs. 8 oz.	13 lbs. 8 oz.	13 lbs. 8 oz.	13 lbs. 8 oz.	19 lbs. 8 oz.	
Furnished	Circuit 2	13 lbs. 8 oz.	13 lbs. 8 oz.	13 lbs. 0 oz.	13 lbs. 0 oz.	20 lbs. 8 oz.	
<b>Heating Performance</b>	<sup>1</sup> Total High Heat Capacity - Btuh		86,000	86,000	100,000	100,000	116,000
	Total Unit Power - kW		7.0	7.0	8.1	8.1	9.5
	<sup>1</sup> C.O.P.		3.60	3.60	3.60	3.60	3.60
	<sup>1</sup> Total Low Heat Capacity - Btuh		47,500	51,000	55,000	56,000	65,000
	Total Unit Power (kW)		6.6	6.6	7.3	7.3	8.5
	<sup>1</sup> C.O.P.		2.22	2.25	2.25	2.25	2.25
<b>Gas Heating Options Available - See page 17</b>			Standard (2 stage), Medium (2 Stage), High (2 Stage)				
<b>Compressor Type (number)</b>			Scroll (2)	Scroll (2)	Scroll (2)	Scroll (2)	Scroll (2)
<b>Outdoor Coils</b>	Net face area (total) - sq. ft.		25.9	25.9	25.9	25.9	40.4
	Tube diameter - in.		3/8	3/8	3/8	3/8	3/8
	Number of rows		3	3	3	3	3
	Fins per inch		20	20	20	20	20
<b>Outdoor Coil Fans</b>	Motor - (No.) horsepower		(2) 1/3 ECM	(2) 1/3 ECM	(2) 1/3 ECM	(2) 1/3 ECM	(3) 1/3 ECM
	Motor rpm		530-950	530-950	650-1010	650-1010	530-950
	Total Motor watts		140-620	140-620	220-700	220-700	180-800
	Diameter - (No.) in.		(2) 24	(2) 24	(2) 24	(2) 24	(3) 24
	Number of blades		3	3	3	3	3
	Total Air volume - cfm		3600-7000	3600-7000	4600-7500	4600-7500	5500-10,600
<b>Indoor Coils</b>	Net face area (total) - sq. ft.		12.8	12.8	12.8	12.8	12.8
	Tube diameter - in.		3/8	3/8	3/8	3/8	3/8
	Number of rows		4	4	4	4	4
	Fins per inch		14	14	14	14	14
Drain connection - Number and size			(1) 1 in. NPT coupling				
Expansion device type			Balance port TXV, removable head				
<b><sup>2</sup> Indoor Blower and Drive Selection</b>	Nominal motor output		2 hp, 3 hp, 5 hp				3.75 hp (ECM)
	Maximum usable motor output (US Only)		2.3 hp, 3.45 hp, 5.75 hp				---
	Motor - Drive kit number		2 hp <sup>3</sup> Kit 1 590-890 rpm Kit 2 800-1105 rpm Kit 3 795-1195 rpm		3 hp Kit 4 730-970 rpm Kit 5 940-1200 rpm Kit 6 1015-1300 rpm		---
			5 hp Kit 10 900-1135 rpm Kit 11 1040-1315 rpm Kit 12 1125-1425 rpm				
Blower wheel nominal diameter x width - in.			(1) 15 X 15	(1) 15 X 15	(1) 15 X 15	(1) 15 X 15	(1) 22 x 19
<b>Filters</b>	Type of filter		Disposable				
	Number and size - in.		(4) 20 x 25 x 2				
<b>Electrical characteristics</b>			208/230V, 460V or 575V - 60 hertz - 3 phase				

NOTE - Net capacity includes evaporator blower motor heat deduction. Gross capacity does not include evaporator blower motor heat deduction.

<sup>1</sup> AHRI Certified to AHRI Standard 340/360:

**Cooling Ratings** - 95°F outdoor air temperature and 80°F db/67°F wb entering indoor coil air.

**High Temperature Heating Ratings** - 47°F db/43°F wb outdoor air temperature and 70°F entering indoor coil air.

**Low Temperature Heating Ratings** - 17°F db/15°F wb outdoor air temperature and 70°F entering indoor coil air.

<sup>2</sup> Using total air volume and system static pressure requirements determine from blower performance tables rpm and motor output required. Maximum usable output of motors furnished are shown. In Canada, nominal motor output is also maximum usable motor output. If motors of comparable output are used, be sure to keep within the service factor limitations outlined on the motor nameplate.

<sup>4</sup> Standard motor and drive kit furnished with unit.

NOTE - Units equipped with MSAV® (Multi-Stage Air Volume) option are limited to a motor service factor of 1.0.



## SPECIFICATIONS - GAS HEAT

		Heat Input Type	Standard	Medium	High
		Number of Gas Heat Stages	2	2	2
Gas Heating Performance	Input - Btuh	First Stage	84,500	117,000	156,000
		Second Stage	130,000	180,000	240,000
	Output - Btuh	Second Stage	104,000	144,000	192,000
	Temperature Rise Range - °F		15-45	30-60	40-70
	Thermal Efficiency		80%	80%	80%
	Gas Supply Connections		3/4 in NPT	3/4 in NPT	3/4 in NPT
Recommended Gas Supply Pressure - in. w.g.	Natural		7	7	7
	LPG/Propane		11	11	11

## HIGH ALTITUDE DERATE

Units may be installed at altitudes up to 2000 feet above sea level without any modification.

At altitudes above 2000 feet, units must be derated to match gas manifold pressures shown in table below.

At altitudes above 4500 feet unit must be derated 2% for each 1000 feet above sea level.

NOTE – This is the only permissible derate for these units.

Gas Heat Type	Altitude	Gas Manifold Pressure		Input Rate Natural Gas or LPG/Propane	
		Natural Gas	LPG/Propane Gas	First Stage	Second Stage
	ft.	In. w.g.	In. w.g.	Btuh	Btuh
Standard	2001-4500	3.4	9.6	84,500	124,000
Medium	2001-4500	3.4	9.6	117,000	172,000
High	2001-4500	3.4	9.6	156,000	230,000

## COOLING/HEATING RATINGS

NOTE – For Temperatures and Capacities not shown in tables, see bulletin – Cooling Unit Rating Table Correction Factor Data in Miscellaneous Engineering Data section.

### 7.5 TON COOLING HIGH EFFICIENCY KDB092H4 (1ST STAGE) - CONSTANT AIR VOLUME

Entering Wet Bulb Temperature	Total Air Volume	Outdoor Air Temperature Entering Outdoor Coil																			
		65°F					75°F					85°F					95°F				
		Total Cool Cap.	Comp. Motor Input	Sensible To Total Ratio (S/T) Dry Bulb			Total Cool Cap.	Comp. Motor Input	Sensible To Total Ratio (S/T) Dry Bulb			Total Cool Cap.	Comp. Motor Input	Sensible To Total Ratio (S/T) Dry Bulb			Total Cool Cap.	Comp. Motor Input	Sensible To Total Ratio (S/T) Dry Bulb		
				75°F	80°F	85°F			75°F	80°F	85°F			75°F	80°F	85°F			75°F	80°F	85°F
cfm	kBtuh	kW	75°F	80°F	85°F	kBtuh	kW	75°F	80°F	85°F	kBtuh	kW	75°F	80°F	85°F	kBtuh	kW	75°F	80°F	85°F	
63°F	2400	49.0	2.33	0.62	0.78	0.97	43.8	2.62	0.62	0.80	1.00	38.4	2.94	0.61	0.82	1.00	32.9	3.31	0.60	0.85	1.00
	3000	52.7	2.35	0.68	0.90	1.00	47.2	2.64	0.69	0.93	1.00	41.8	2.96	0.69	0.96	1.00	36.1	3.33	0.70	1.00	1.00
	3600	55.5	2.37	0.76	0.99	1.00	50.2	2.66	0.77	1.00	1.00	45.0	2.99	0.79	1.00	1.00	39.8	3.36	0.82	1.00	1.00
67°F	2400	53.8	2.36	0.48	0.60	0.74	48.4	2.65	0.47	0.60	0.76	42.9	2.97	0.44	0.60	0.77	37.2	3.34	0.42	0.59	0.80
	3000	57.3	2.38	0.53	0.67	0.85	51.8	2.67	0.51	0.67	0.88	45.9	2.99	0.50	0.68	0.92	39.9	3.36	0.48	0.69	0.96
	3600	59.9	2.40	0.56	0.74	0.95	54.2	2.68	0.55	0.75	0.98	48.1	3.01	0.55	0.77	1.00	42.0	3.38	0.53	0.80	1.00
71°F	2400	58.5	2.39	0.36	0.48	0.59	53.1	2.67	0.34	0.47	0.59	47.4	3.00	0.31	0.45	0.59	41.6	3.37	0.27	0.42	0.58
	3000	62.2	2.41	0.38	0.52	0.65	56.4	2.70	0.37	0.51	0.66	50.5	3.02	0.34	0.50	0.66	44.4	3.39	0.30	0.49	0.67
	3600	64.7	2.43	0.41	0.56	0.72	58.8	2.71	0.39	0.55	0.73	52.8	3.04	0.37	0.55	0.75	46.3	3.41	0.33	0.54	0.77

### 7.5 TON COOLING HIGH EFFICIENCY KDB092H4 (2ND STAGE) - CONSTANT AIR VOLUME

Entering Wet Bulb Temperature	Total Air Volume	Outdoor Air Temperature Entering Outdoor Coil																			
		85°F					95°F					105°F					115°F				
		Total Cool Cap.	Comp. Motor Input	Sensible To Total Ratio (S/T) Dry Bulb			Total Cool Cap.	Comp. Motor Input	Sensible To Total Ratio (S/T) Dry Bulb			Total Cool Cap.	Comp. Motor Input	Sensible To Total Ratio (S/T) Dry Bulb			Total Cool Cap.	Comp. Motor Input	Sensible To Total Ratio (S/T) Dry Bulb		
				75°F	80°F	85°F			75°F	80°F	85°F			75°F	80°F	85°F			75°F	80°F	85°F
cfm	kBtuh	kW	75°F	80°F	85°F	kBtuh	kW	75°F	80°F	85°F	kBtuh	kW	75°F	80°F	85°F	kBtuh	kW	75°F	80°F	85°F	
63°F	2400	89.0	5.20	0.69	0.84	0.99	81.7	5.90	0.69	0.86	1.00	74.1	6.69	0.70	0.89	1.00	66.1	7.63	0.72	0.94	1.00
	3000	94.7	5.21	0.75	0.94	1.00	87.0	5.90	0.76	0.97	1.00	79.0	6.69	0.78	1.00	1.00	71.5	7.62	0.82	1.00	1.00
	3600	99.1	5.23	0.81	1.00	1.00	92.1	5.90	0.83	1.00	1.00	84.7	6.71	0.87	1.00	1.00	76.8	7.63	0.91	1.00	1.00
67°F	2400	96.6	5.22	0.53	0.66	0.80	88.8	5.90	0.52	0.67	0.83	80.8	6.70	0.52	0.68	0.85	72.4	7.63	0.52	0.70	0.89
	3000	101.9	5.23	0.57	0.73	0.90	93.7	5.91	0.57	0.74	0.93	85.4	6.70	0.57	0.76	0.96	76.4	7.64	0.57	0.79	1.00
	3600	105.8	5.24	0.60	0.79	0.98	97.3	5.91	0.61	0.81	1.00	88.6	6.71	0.62	0.84	1.00	79.4	7.62	0.63	0.88	1.00
71°F	2400	103.6	5.24	0.39	0.51	0.64	95.8	5.92	0.38	0.52	0.65	87.6	6.70	0.36	0.51	0.66	78.9	7.63	0.34	0.51	0.68
	3000	109.5	5.25	0.41	0.56	0.71	101.3	5.93	0.40	0.56	0.72	92.3	6.71	0.39	0.57	0.74	83.2	7.64	0.37	0.57	0.76
	3600	113.4	5.26	0.43	0.60	0.77	104.9	5.94	0.41	0.60	0.79	95.8	6.72	0.41	0.62	0.82	85.9	7.64	0.40	0.62	0.86

### 7.5 TON HEATING HIGH EFFICIENCY KDB092H4 - CONSTANT AIR VOLUME

Indoor Coil Air Volume 70°F Dry Bulb cfm	Air Temperature Entering Outdoor Coil									
	65°F		45°F		25°F		5°F		-15°F	
	Total Heating Capacity	Comp. Motor Input	Total Heating Capacity	Comp. Motor Input	Total Heating Capacity	Comp. Motor Input	Total Heating Capacity	Comp. Motor Input	Total Heating Capacity	Comp. Motor Input
	kBtuh	kW	kBtuh	kW	kBtuh	kW	kBtuh	kW	kBtuh	kW
2400	113.5	5.44	86.6	5.53	59.9	5.65	34.9	5.24	17.5	3.84
3000	115.5	5.07	88.6	5.17	61.9	5.28	36.9	4.88	19.5	3.48
3600	117.3	4.85	90.5	4.94	63.7	5.06	38.7	4.65	21.4	3.25

## COOLING/HEATING RATINGS

NOTE – For Temperatures and Capacities not shown in tables, see bulletin – Cooling Unit Rating Table Correction Factor Data in Miscellaneous Engineering Data section.

### 8.5 TON COOLING HIGH EFFICIENCY KDB102H4 (1ST STAGE) - CONSTANT AIR VOLUME

Entering Wet Bulb Temperature	Total Air Volume	Outdoor Air Temperature Entering Outdoor Coil																							
		65°F						75°F						85°F						95°F					
		Total Cool Cap.	Comp. Motor Input	Sensible To Total Ratio (S/T)			Total Cool Cap.	Comp. Motor Input	Sensible To Total Ratio (S/T)			Total Cool Cap.	Comp. Motor Input	Sensible To Total Ratio (S/T)			Total Cool Cap.	Comp. Motor Input	Sensible To Total Ratio (S/T)						
				Dry Bulb					Dry Bulb					Dry Bulb					Dry Bulb						
		cfm	kBtuh	kW	75°F	80°F	85°F	kBtuh	kW	75°F	80°F	85°F	kBtuh	kW	75°F	80°F	85°F	kBtuh	kW	75°F	80°F	85°F			
63°F	2720	56.5	2.64	0.63	0.79	0.97	50.8	3.00	0.62	0.80	0.99	45.1	3.40	0.62	0.82	1.00	39.2	3.84	0.61	0.85	1.00				
	3400	60.6	2.66	0.68	0.89	1.00	54.8	3.03	0.69	0.92	1.00	48.8	3.43	0.70	0.96	1.00	42.8	3.87	0.71	0.99	1.00				
	4080	63.8	2.69	0.76	0.99	1.00	58.0	3.05	0.77	1.00	1.00	52.5	3.46	0.79	1.00	1.00	46.7	3.90	0.81	1.00	1.00				
67°F	2720	61.8	2.67	0.49	0.61	0.75	56.2	3.04	0.47	0.61	0.76	50.3	3.43	0.45	0.60	0.78	44.0	3.88	0.43	0.60	0.80				
	3400	65.8	2.69	0.53	0.67	0.85	59.9	3.06	0.52	0.67	0.88	53.7	3.46	0.51	0.68	0.91	47.2	3.90	0.49	0.69	0.95				
	4080	68.8	2.72	0.57	0.74	0.95	62.6	3.08	0.56	0.75	0.98	56.1	3.48	0.55	0.77	1.00	49.6	3.92	0.55	0.79	1.00				
71°F	2720	67.3	2.70	0.37	0.48	0.60	61.4	3.07	0.35	0.47	0.59	55.4	3.47	0.32	0.46	0.59	48.9	3.91	0.28	0.43	0.59				
	3400	71.3	2.73	0.39	0.52	0.65	65.2	3.10	0.37	0.52	0.66	58.9	3.50	0.35	0.51	0.66	52.2	3.95	0.31	0.49	0.67				
	4080	74.3	2.75	0.41	0.56	0.72	67.9	3.12	0.39	0.56	0.73	61.3	3.52	0.37	0.55	0.75	54.6	3.97	0.34	0.55	0.77				

### 8.5 TON COOLING HIGH EFFICIENCY KDB102H4 (2ND STAGE) - CONSTANT AIR VOLUME

Entering Wet Bulb Temperature	Total Air Volume	Outdoor Air Temperature Entering Outdoor Coil																							
		85°F						95°F						105°F						115°F					
		Total Cool Cap.	Comp. Motor Input	Sensible To Total Ratio (S/T)			Total Cool Cap.	Comp. Motor Input	Sensible To Total Ratio (S/T)			Total Cool Cap.	Comp. Motor Input	Sensible To Total Ratio (S/T)			Total Cool Cap.	Comp. Motor Input	Sensible To Total Ratio (S/T)						
				Dry Bulb					Dry Bulb					Dry Bulb					Dry Bulb						
		cfm	kBtuh	kW	75°F	80°F	85°F	kBtuh	kW	75°F	80°F	85°F	kBtuh	kW	75°F	80°F	85°F	kBtuh	kW	75°F	80°F	85°F			
63°F	2720	100.8	5.51	0.66	0.83	1.00	93.3	6.23	0.67	0.85	1.00	85.4	7.06	0.68	0.89	1.00	76.9	8.02	0.70	0.94	1.00				
	3400	106.8	5.53	0.72	0.94	1.00	98.8	6.24	0.74	0.97	1.00	90.7	7.07	0.77	1.00	1.00	82.9	8.03	0.80	1.00	1.00				
	4080	111.8	5.54	0.79	1.00	1.00	104.3	6.25	0.82	1.00	1.00	96.6	7.08	0.86	1.00	1.00	88.3	8.03	0.91	1.00	1.00				
67°F	2720	108.7	5.53	0.51	0.64	0.78	100.7	6.25	0.51	0.65	0.81	92.3	7.06	0.51	0.66	0.84	83.5	8.03	0.51	0.68	0.89				
	3400	114.1	5.55	0.55	0.70	0.89	106.0	6.26	0.55	0.71	0.93	97.1	7.08	0.56	0.74	0.97	87.5	8.04	0.56	0.77	1.00				
	4080	118.3	5.56	0.58	0.77	0.98	109.7	6.27	0.59	0.79	1.00	100.4	7.09	0.60	0.83	1.00	90.8	8.03	0.61	0.88	1.00				
71°F	2720	116.4	5.55	0.38	0.50	0.61	108.1	6.26	0.37	0.50	0.63	99.5	7.08	0.36	0.50	0.64	90.4	8.04	0.35	0.51	0.66				
	3400	122.1	5.57	0.40	0.54	0.68	113.5	6.28	0.39	0.54	0.69	104.4	7.10	0.38	0.55	0.71	94.7	8.04	0.37	0.56	0.75				
	4080	126.4	5.58	0.41	0.58	0.74	117.4	6.29	0.41	0.58	0.77	108.0	7.10	0.41	0.60	0.81	97.6	8.05	0.40	0.61	0.85				

### 8.5 TON HEATING HIGH EFFICIENCY KDB102H4 - CONSTANT AIR VOLUME

Indoor Coil Air Volume 70°F Dry Bulb cfm	Air Temperature Entering Outdoor Coil									
	65°F		45°F		25°F		5°F		-15°F	
	Total Heating Capacity	Comp. Motor Input	Total Heating Capacity	Comp. Motor Input	Total Heating Capacity	Comp. Motor Input	Total Heating Capacity	Comp. Motor Input	Total Heating Capacity	Comp. Motor Input
	kBtuh	kW	kBtuh	kW	kBtuh	kW	kBtuh	kW	kBtuh	kW
2720	128.8	6.27	99.5	6.41	71.5	6.63	38.5	5.92	19.5	4.34
3400	131.0	5.86	101.7	6.00	73.7	6.21	40.7	5.51	21.7	3.93
4080	132.8	5.60	103.6	5.74	75.5	5.95	42.5	5.25	23.5	3.67

## COOLING/HEATING RATINGS

NOTE – For Temperatures and Capacities not shown in tables, see bulletin – Cooling Unit Rating Table Correction Factor Data in Miscellaneous Engineering Data section.

### 7.5 TON COOLING HIGH EFFICIENCY KDB092H4 (1ST STAGE) - MSAV (Multi-Stage Air Volume) SUPPLY AIR BLOWER

Entering Wet Bulb Temperature	Total Air Volume	Outdoor Air Temperature Entering Outdoor Coil																							
		65°F						75°F						85°F						95°F					
		Total Cool Cap.	Comp. Motor Input	Sensible To Total Ratio (S/T) Dry Bulb			Total Cool Cap.	Comp. Motor Input	Sensible To Total Ratio (S/T) Dry Bulb			Total Cool Cap.	Comp. Motor Input	Sensible To Total Ratio (S/T) Dry Bulb			Total Cool Cap.	Comp. Motor Input	Sensible To Total Ratio (S/T) Dry Bulb						
				75°F	80°F	85°F			75°F	80°F	85°F			75°F	80°F	85°F			75°F	80°F	85°F				
cfm	kBtuh	kW	75°F	80°F	85°F	kBtuh	kW	75°F	80°F	85°F	kBtuh	kW	75°F	80°F	85°F	kBtuh	kW	75°F	80°F	85°F					
63°F	1680	43.4	2.26	0.61	0.72	0.85	39.9	2.54	0.60	0.73	0.86	36.2	2.87	0.59	0.73	0.88	32.3	3.24	0.58	0.74	0.90				
	2100	47.1	2.29	0.65	0.79	0.93	43.2	2.57	0.65	0.80	0.95	39.2	2.89	0.65	0.81	0.97	35.1	3.26	0.65	0.83	1.00				
	2520	49.8	2.31	0.69	0.85	0.99	45.8	2.59	0.70	0.87	1.00	41.6	2.91	0.70	0.89	1.00	37.4	3.28	0.71	0.92	1.00				
67°F	1680	47.2	2.29	0.49	0.59	0.69	43.6	2.57	0.47	0.58	0.69	39.7	2.89	0.45	0.57	0.70	35.7	3.26	0.43	0.57	0.71				
	2100	51.0	2.31	0.51	0.63	0.76	47.1	2.60	0.50	0.63	0.76	42.8	2.92	0.49	0.63	0.78	38.7	3.29	0.48	0.63	0.79				
	2520	53.8	2.34	0.54	0.67	0.81	49.6	2.62	0.53	0.68	0.83	45.2	2.94	0.52	0.68	0.85	40.7	3.31	0.51	0.70	0.88				
71°F	1680	51.2	2.31	0.38	0.48	0.57	47.4	2.60	0.36	0.46	0.56	43.3	2.92	0.34	0.45	0.55	39.2	3.29	0.31	0.43	0.55				
	2100	55.0	2.34	0.39	0.50	0.61	50.8	2.63	0.37	0.49	0.61	46.6	2.95	0.36	0.48	0.61	42.2	3.32	0.33	0.47	0.61				
	2520	57.7	2.36	0.41	0.53	0.65	53.5	2.65	0.40	0.53	0.66	48.9	2.97	0.37	0.52	0.66	44.3	3.34	0.35	0.51	0.67				

### 7.5 TON COOLING HIGH EFFICIENCY KDB092H4 (2ND STAGE) - MSAV (Multi-Stage Air Volume) SUPPLY AIR BLOWER

Entering Wet Bulb Temperature	Total Air Volume	Outdoor Air Temperature Entering Outdoor Coil																							
		85°F						95°F						105°F						115°F					
		Total Cool Cap.	Comp. Motor Input	Sensible To Total Ratio (S/T) Dry Bulb			Total Cool Cap.	Comp. Motor Input	Sensible To Total Ratio (S/T) Dry Bulb			Total Cool Cap.	Comp. Motor Input	Sensible To Total Ratio (S/T) Dry Bulb			Total Cool Cap.	Comp. Motor Input	Sensible To Total Ratio (S/T) Dry Bulb						
				75°F	80°F	85°F			75°F	80°F	85°F			75°F	80°F	85°F			75°F	80°F	85°F				
cfm	kBtuh	kW	75°F	80°F	85°F	kBtuh	kW	75°F	80°F	85°F	kBtuh	kW	75°F	80°F	85°F	kBtuh	kW	75°F	80°F	85°F					
63°F	2400	87.5	5.26	0.68	0.84	0.99	80.2	5.96	0.69	0.86	1.00	72.8	6.76	0.70	0.89	1.00	64.8	7.72	0.72	0.94	1.00				
	3000	93.1	5.27	0.75	0.94	1.00	85.5	5.96	0.76	0.97	1.00	77.6	6.76	0.78	1.00	1.00	70.2	7.71	0.81	1.00	1.00				
	3600	97.4	5.28	0.81	1.00	1.00	90.5	5.97	0.83	1.00	1.00	83.2	6.78	0.87	1.00	1.00	75.4	7.71	0.91	1.00	1.00				
67°F	2400	94.8	5.27	0.52	0.66	0.80	87.2	5.96	0.52	0.67	0.82	79.3	6.77	0.52	0.68	0.85	71.0	7.71	0.51	0.70	0.89				
	3000	100.2	5.29	0.57	0.73	0.90	92.1	5.97	0.57	0.74	0.93	83.9	6.78	0.57	0.76	0.96	75.0	7.72	0.57	0.79	1.00				
	3600	104.0	5.30	0.60	0.79	0.98	95.7	5.98	0.61	0.81	1.00	87.0	6.78	0.61	0.84	1.00	77.9	7.70	0.63	0.88	1.00				
71°F	2400	101.9	5.29	0.38	0.51	0.64	94.1	5.98	0.37	0.52	0.65	86.0	6.77	0.36	0.51	0.66	77.5	7.72	0.34	0.51	0.68				
	3000	107.6	5.30	0.41	0.56	0.71	99.5	5.99	0.40	0.56	0.72	90.6	6.79	0.39	0.56	0.74	81.7	7.72	0.37	0.57	0.76				
	3600	111.5	5.32	0.43	0.59	0.77	103.1	6.00	0.41	0.60	0.79	94.1	6.79	0.41	0.62	0.82	84.4	7.72	0.40	0.62	0.86				

### 7.5 TON HEATING HIGH EFFICIENCY KDB092H4 - MSAV (Multi-Stage Air Volume) SUPPLY AIR BLOWER

Indoor Coil Air Volume 70°F Dry Bulb cfm	Air Temperature Entering Outdoor Coil									
	65°F		45°F		25°F		5°F		-15°F	
	Total Heating Capacity	Comp. Motor Input	Total Heating Capacity	Comp. Motor Input	Total Heating Capacity	Comp. Motor Input	Total Heating Capacity	Comp. Motor Input	Total Heating Capacity	Comp. Motor Input
2400	109.5	5.49	82.8	5.53	56.6	5.56	31.0	5.28	15.7	3.87
3000	111.5	5.12	84.8	5.16	58.5	5.19	33.0	4.91	17.7	3.50
3600	113.1	4.89	86.5	4.93	60.2	4.96	34.6	4.68	19.3	3.27

## COOLING/HEATING RATINGS

NOTE – For Temperatures and Capacities not shown in tables, see bulletin – Cooling Unit Rating Table Correction Factor Data in Miscellaneous Engineering Data section.

### 8.5 TON COOLING HIGH EFFICIENCY KDB102H4 (1ST STAGE) - MSAV (Multi-Stage Air Volume) SUPPLY AIR BLOWER

Entering Wet Bulb Temperature	Total Air Volume	Outdoor Air Temperature Entering Outdoor Coil																			
		65°F					75°F					85°F					95°F				
		Total Cool Cap.	Comp. Motor Input	Sensible To Total Ratio (S/T)			Total Cool Cap.	Comp. Motor Input	Sensible To Total Ratio (S/T)			Total Cool Cap.	Comp. Motor Input	Sensible To Total Ratio (S/T)			Total Cool Cap.	Comp. Motor Input	Sensible To Total Ratio (S/T)		
				Dry Bulb					Dry Bulb					Dry Bulb					Dry Bulb		
		cfm	kBtuh	kW	75°F	80°F	85°F	kBtuh	kW	75°F	80°F	85°F	kBtuh	kW	75°F	80°F	85°F	kBtuh	kW	75°F	80°F
63°F	1920	50.7	2.57	0.61	0.72	0.85	47.4	2.92	0.61	0.73	0.86	43.9	3.31	0.60	0.73	0.88	40.3	3.74	0.60	0.75	0.90
	2400	54.5	2.59	0.64	0.79	0.93	51.0	2.95	0.65	0.79	0.95	47.2	3.34	0.65	0.81	0.97	43.3	3.78	0.66	0.83	1.00
	2880	57.2	2.61	0.68	0.84	0.99	53.6	2.98	0.69	0.86	1.00	49.6	3.37	0.70	0.89	1.00	45.5	3.80	0.71	0.92	1.00
67°F	1920	54.6	2.59	0.49	0.59	0.69	51.2	2.95	0.48	0.59	0.69	47.6	3.34	0.47	0.58	0.70	43.9	3.78	0.46	0.58	0.71
	2400	58.6	2.62	0.51	0.62	0.75	54.9	2.98	0.51	0.63	0.76	51.0	3.38	0.50	0.63	0.77	47.0	3.82	0.50	0.64	0.79
	2880	61.3	2.65	0.53	0.66	0.81	57.6	3.01	0.53	0.67	0.83	53.6	3.40	0.53	0.68	0.85	49.1	3.84	0.53	0.69	0.88
71°F	1920	58.6	2.62	0.39	0.47	0.57	55.1	2.99	0.37	0.47	0.56	51.4	3.38	0.36	0.46	0.56	47.5	3.82	0.34	0.45	0.56
	2400	62.7	2.66	0.39	0.50	0.60	58.9	3.02	0.38	0.49	0.60	54.8	3.41	0.37	0.49	0.61	50.7	3.85	0.36	0.49	0.62
	2880	65.5	2.68	0.40	0.52	0.64	61.6	3.05	0.40	0.52	0.65	57.4	3.44	0.38	0.52	0.66	52.9	3.87	0.38	0.52	0.67

### 8.5 TON COOLING HIGH EFFICIENCY KDB102H4 (2ND STAGE) - MSAV (Multi-Stage Air Volume) SUPPLY AIR BLOWER

Entering Wet Bulb Temperature	Total Air Volume	Outdoor Air Temperature Entering Outdoor Coil																			
		85°F					95°F					105°F					115°F				
		Total Cool Cap.	Comp. Motor Input	Sensible To Total Ratio (S/T)			Total Cool Cap.	Comp. Motor Input	Sensible To Total Ratio (S/T)			Total Cool Cap.	Comp. Motor Input	Sensible To Total Ratio (S/T)			Total Cool Cap.	Comp. Motor Input	Sensible To Total Ratio (S/T)		
				Dry Bulb					Dry Bulb					Dry Bulb					Dry Bulb		
		cfm	kBtuh	kW	75°F	80°F	85°F	kBtuh	kW	75°F	80°F	85°F	kBtuh	kW	75°F	80°F	85°F	kBtuh	kW	75°F	80°F
63°F	2720	99.5	5.93	0.68	0.84	1.00	89.3	6.73	0.68	0.86	1.00	78.9	7.64	0.68	0.89	1.00	67.9	8.65	0.69	0.94	1.00
	3400	106.7	5.95	0.75	0.94	1.00	96.0	6.76	0.76	0.97	1.00	85.5	7.66	0.78	1.00	1.00	75.1	8.69	0.80	1.00	1.00
	4080	112.7	5.97	0.82	1.00	1.00	103.0	6.79	0.83	1.00	1.00	92.8	7.70	0.86	1.00	1.00	82.0	8.72	0.90	1.00	1.00
67°F	2720	109.2	5.96	0.51	0.66	0.81	98.7	6.77	0.50	0.66	0.82	87.7	7.67	0.48	0.66	0.85	76.2	8.69	0.46	0.67	0.89
	3400	115.9	5.98	0.56	0.73	0.90	105.2	6.80	0.55	0.74	0.93	93.6	7.70	0.54	0.76	0.97	81.2	8.71	0.53	0.78	1.00
	4080	121.0	6.01	0.60	0.80	0.98	109.6	6.82	0.60	0.81	1.00	97.8	7.72	0.60	0.84	1.00	85.3	8.73	0.59	0.88	1.00
71°F	2720	118.9	5.99	0.37	0.50	0.63	108.0	6.80	0.34	0.49	0.64	96.7	7.70	0.31	0.48	0.65	84.9	8.73	0.28	0.47	0.65
	3400	125.9	6.02	0.39	0.55	0.70	114.6	6.83	0.37	0.55	0.72	102.8	7.74	0.35	0.54	0.73	90.2	8.75	0.31	0.54	0.76
	4080	131.0	6.04	0.42	0.60	0.78	119.3	6.85	0.39	0.59	0.79	107.2	7.76	0.38	0.60	0.82	93.8	8.77	0.35	0.60	0.86

### 8.5 TON HEATING HIGH EFFICIENCY KDB102H4 - MSAV (Multi-Stage Air Volume) SUPPLY AIR BLOWER

Indoor Coil Air Volume 70°F Dry Bulb cfm	Air Temperature Entering Outdoor Coil									
	65°F		45°F		25°F		5°F		-15°F	
	Total Heating Capacity	Comp. Motor Input	Total Heating Capacity	Comp. Motor Input	Total Heating Capacity	Comp. Motor Input	Total Heating Capacity	Comp. Motor Input	Total Heating Capacity	Comp. Motor Input
	kBtuh	kW	kBtuh	kW	kBtuh	kW	kBtuh	kW	kBtuh	kW
2720	125.3	6.31	94.9	6.44	65.0	6.58	35.4	6.26	18.0	4.57
3400	127.5	5.89	97.1	6.03	67.2	6.16	37.6	5.84	20.2	4.15
4080	129.2	5.62	98.8	5.76	68.9	5.89	39.3	5.57	21.9	3.88

## COOLING/HEATING RATINGS

NOTE – For Temperatures and Capacities not shown in tables, see bulletin – Cooling Unit Rating Table Correction Factor Data in Miscellaneous Engineering Data section.

### 10 TON COOLING HIGH EFFICIENCY KDB122H4 (1ST STAGE) - MSAV (Multi-Stage Air Volume) SUPPLY AIR BLOWER

Entering Wet Bulb Temperature	Total Air Volume	Outdoor Air Temperature Entering Outdoor Coil																			
		65°F					75°F					85°F					95°F				
		Total Cool Cap.	Comp. Motor Input	Sensible To Total Ratio (S/T) Dry Bulb			Total Cool Cap.	Comp. Motor Input	Sensible To Total Ratio (S/T) Dry Bulb			Total Cool Cap.	Comp. Motor Input	Sensible To Total Ratio (S/T) Dry Bulb			Total Cool Cap.	Comp. Motor Input	Sensible To Total Ratio (S/T) Dry Bulb		
				75°F	80°F	85°F			75°F	80°F	85°F			75°F	80°F	85°F			75°F	80°F	85°F
63°F	2240	57.7	3.00	0.62	0.73	0.84	55.0	3.39	0.63	0.74	0.85	51.8	3.83	0.63	0.75	0.87	48.7	4.32	0.63	0.76	0.89
	2800	61.6	3.04	0.65	0.78	0.90	58.7	3.44	0.66	0.79	0.92	55.5	3.88	0.67	0.81	0.95	52.0	4.38	0.68	0.83	0.97
	3360	64.7	3.08	0.68	0.83	0.97	61.3	3.48	0.70	0.85	0.99	57.7	3.92	0.71	0.87	1.00	54.1	4.41	0.72	0.89	1.00
67°F	2240	61.6	3.04	0.51	0.60	0.69	58.7	3.44	0.51	0.60	0.70	55.6	3.88	0.50	0.60	0.71	52.3	4.38	0.50	0.61	0.72
	2800	65.8	3.10	0.52	0.63	0.74	62.5	3.49	0.52	0.63	0.75	59.2	3.93	0.52	0.64	0.77	55.6	4.43	0.53	0.65	0.79
	3360	68.8	3.13	0.54	0.66	0.80	65.4	3.53	0.55	0.67	0.81	61.8	3.97	0.55	0.68	0.83	58.0	4.47	0.55	0.70	0.86
71°F	2240	65.6	3.09	0.40	0.49	0.57	62.5	3.49	0.40	0.49	0.58	59.3	3.94	0.39	0.49	0.58	55.8	4.44	0.38	0.49	0.59
	2800	69.8	3.15	0.41	0.51	0.61	66.5	3.55	0.40	0.51	0.61	62.9	3.99	0.40	0.51	0.62	59.2	4.49	0.39	0.51	0.63
	3360	72.9	3.19	0.41	0.53	0.64	69.4	3.59	0.41	0.53	0.65	65.5	4.03	0.41	0.53	0.66	61.6	4.54	0.41	0.54	0.68

### 10 TON COOLING HIGH EFFICIENCY KDB122H4 (2ND STAGE) - MSAV (Multi-Stage Air Volume) SUPPLY AIR BLOWER

Entering Wet Bulb Temperature	Total Air Volume	Outdoor Air Temperature Entering Outdoor Coil																			
		85°F					95°F					105°F					115°F				
		Total Cool Cap.	Comp. Motor Input	Sensible To Total Ratio (S/T) Dry Bulb			Total Cool Cap.	Comp. Motor Input	Sensible To Total Ratio (S/T) Dry Bulb			Total Cool Cap.	Comp. Motor Input	Sensible To Total Ratio (S/T) Dry Bulb			Total Cool Cap.	Comp. Motor Input	Sensible To Total Ratio (S/T) Dry Bulb		
				75°F	80°F	85°F			75°F	80°F	85°F			75°F	80°F	85°F			75°F	80°F	85°F
63°F	3200	122.5	6.90	0.69	0.83	0.98	113.3	7.82	0.69	0.85	1.00	103.8	8.85	0.70	0.88	1.00	93.8	10.09	0.72	0.91	1.00
	4000	130.0	6.94	0.75	0.92	1.00	120.4	7.85	0.75	0.94	1.00	110.7	8.91	0.78	0.97	1.00	100.1	10.11	0.80	1.00	1.00
	4800	136.0	6.98	0.80	0.98	1.00	126.1	7.89	0.82	1.00	1.00	116.8	8.95	0.85	1.00	1.00	106.9	10.16	0.88	1.00	1.00
67°F	3200	132.1	6.94	0.53	0.66	0.80	122.5	7.86	0.53	0.67	0.82	112.9	8.91	0.53	0.68	0.84	102.1	10.13	0.53	0.70	0.87
	4000	139.7	6.99	0.57	0.72	0.88	129.5	7.90	0.57	0.73	0.90	119.1	8.95	0.57	0.75	0.94	107.9	10.17	0.58	0.78	0.97
	4800	145.1	7.03	0.60	0.78	0.95	134.7	7.95	0.61	0.80	0.98	123.7	8.99	0.62	0.82	1.00	111.8	10.18	0.62	0.85	1.00
71°F	3200	141.8	6.99	0.40	0.52	0.64	132.0	7.92	0.39	0.52	0.65	121.9	8.98	0.37	0.52	0.66	110.7	10.16	0.36	0.52	0.68
	4000	149.6	7.06	0.42	0.56	0.70	139.0	7.98	0.40	0.56	0.71	128.2	9.02	0.40	0.56	0.73	116.5	10.20	0.39	0.57	0.76
	4800	155.1	7.10	0.43	0.59	0.76	144.4	8.01	0.43	0.60	0.78	133.1	9.06	0.42	0.61	0.80	120.4	10.23	0.41	0.62	0.83

### 10 TON HEATING HIGH EFFICIENCY KDB122H4 - MSAV (Multi-Stage Air Volume) SUPPLY AIR BLOWER

Indoor Coil Air Volume 70°F Dry Bulb cfm	Air Temperature Entering Outdoor Coil									
	65°F		45°F		25°F		5°F		-15°F	
	Total Heating Capacity	Comp. Motor Input	Total Heating Capacity	Comp. Motor Input	Total Heating Capacity	Comp. Motor Input	Total Heating Capacity	Comp. Motor Input	Total Heating Capacity	Comp. Motor Input
	kBtuh	kW	kBtuh	kW	kBtuh	kW	kBtuh	kW	kBtuh	kW
3200	146.5	7.92	112.1	7.73	77.6	7.55	46.4	6.93	23.1	5.12
4000	149.3	7.43	114.9	7.24	80.4	7.05	49.2	6.43	25.9	4.63
4800	151.3	7.10	116.9	6.91	82.4	6.73	51.3	6.11	28.0	4.30

**BLOWER DATA**

**BELT DRIVE - 7.5 TON | 8.5 TON**

**KDB092H4B, KDB102H4B - BASE UNIT**

**BLOWER TABLE INCLUDES RESISTANCE FOR BASE UNIT ONLY (NO HEAT SECTION) WITH DRY INDOOR COIL AND AIR FILTERS IN PLACE. FOR ALL UNITS ADD:**

- 1 – Wet indoor coil air resistance of selected unit.
- 2 – Any factory installed options air resistance (heat section, economizer, etc.)
- 3 – Any field installed accessories air resistance (duct resistance, diffuser, etc.)

Then determine from blower table blower motor output required.

See page 25 for blower motors and drives.

See page 25 for wet coil and option/accessory air resistance data.

**MAXIMUM STATIC PRESSURE WITH GAS HEAT - 2.0 in. w.g.**

Total Air Volume cfm	Total Static Pressure – in. w.g.													
	0.2		0.4		0.6		0.8		1.0		1.2		1.4	
	RPM	BHP	RPM	BHP	RPM	BHP	RPM	BHP	RPM	BHP	RPM	BHP	RPM	BHP
1750	480	0.19	548	0.39	618	0.57	689	0.70	758	0.81	824	0.92	885	1.07
2000	492	0.27	560	0.47	629	0.64	700	0.77	768	0.88	832	1.00	892	1.16
2250	505	0.35	573	0.55	643	0.72	713	0.85	780	0.97	842	1.10	900	1.25
2500	520	0.45	588	0.64	658	0.81	727	0.94	793	1.07	853	1.21	909	1.37
2750	536	0.55	604	0.74	674	0.91	743	1.05	806	1.19	865	1.34	919	1.50
3000	553	0.66	622	0.85	692	1.02	760	1.17	821	1.32	878	1.48	930	1.64
3250	572	0.77	641	0.98	712	1.15	778	1.32	837	1.48	892	1.64	942	1.81
3500	592	0.90	663	1.12	733	1.31	798	1.48	854	1.65	907	1.82	955	1.99
3750	614	1.04	687	1.28	756	1.48	818	1.66	872	1.83	922	2.01	969	2.19
4000	639	1.22	712	1.47	780	1.67	838	1.85	890	2.03	939	2.22	983	2.42
4250	666	1.42	740	1.68	804	1.88	859	2.06	909	2.25	956	2.45	998	2.67
4500	697	1.65	769	1.91	829	2.10	881	2.28	929	2.48	973	2.71	1013	2.95
4750	729	1.91	798	2.15	854	2.34	903	2.53	948	2.75	991	3.00	1030	3.27
5000	763	2.18	826	2.41	878	2.60	925	2.81	968	3.05	1009	3.33	1046	3.61
5250	797	2.47	854	2.69	903	2.90	947	3.12	989	3.39	1028	3.69	1064	3.99
5500	830	2.78	882	3.00	927	3.22	969	3.48	1010	3.77	1047	4.09	1083	4.40
5750	861	3.11	908	3.34	951	3.58	992	3.87	1031	4.19	1068	4.52	1102	4.84
6000	890	3.45	935	3.71	976	3.98	1016	4.31	1053	4.65	1089	4.99	1122	5.30
6250	918	3.84	961	4.12	1001	4.43	1040	4.79	1076	5.14	1110	5.48	---	---

Total Air Volume cfm	Total Static Pressure – in. w.g.											
	1.6		1.8		2		2.2		2.4		2.6	
	RPM	BHP	RPM	BHP	RPM	BHP	RPM	BHP	RPM	BHP	RPM	BHP
1750	941	1.23	992	1.40	1039	1.55	1084	1.70	1128	1.85	1156	2.08
2000	946	1.32	995	1.48	1041	1.65	1085	1.81	1127	1.97	1160	2.13
2250	952	1.42	999	1.59	1044	1.76	1087	1.93	1127	2.10	1164	2.27
2500	959	1.54	1005	1.71	1048	1.89	1089	2.07	1127	2.25	1166	2.42
2750	968	1.67	1012	1.86	1053	2.04	1092	2.23	1129	2.41	1167	2.60
3000	977	1.83	1020	2.02	1059	2.21	1096	2.41	1133	2.60	1170	2.79
3250	988	2.00	1028	2.20	1066	2.41	1102	2.61	1138	2.81	1174	3.01
3500	999	2.19	1038	2.41	1074	2.63	1109	2.84	1144	3.04	1180	3.24
3750	1010	2.41	1048	2.64	1084	2.87	1118	3.09	1152	3.29	1188	3.50
4000	1023	2.65	1060	2.90	1095	3.14	1128	3.36	1162	3.57	1198	3.77
4250	1036	2.92	1072	3.18	1106	3.42	1139	3.65	1172	3.86	1208	4.07
4500	1050	3.22	1085	3.48	1118	3.73	1151	3.96	1184	4.17	1221	4.39
4750	1065	3.55	1099	3.81	1132	4.06	1164	4.29	1198	4.51	1235	4.74
5000	1081	3.90	1114	4.17	1146	4.42	1178	4.65	1212	4.87	1250	5.09
5250	1098	4.28	1130	4.55	1162	4.80	1194	5.02	1228	5.24	1266	5.47
5500	1116	4.69	1147	4.96	1179	5.20	1211	5.42	1246	5.63	---	---
5750	1134	5.12	1165	5.38	1196	5.61	---	---	---	---	---	---
6000	1153	5.58	---	---	---	---	---	---	---	---	---	---
6250	---	---	---	---	---	---	---	---	---	---	---	---

**BLOWER DATA**

**DIRECT DRIVE - 10 TON**

**KDB122H4E - BASE UNIT**

**BLOWER TABLE INCLUDES RESISTANCE FOR BASE UNIT ONLY (NO HEAT SECTION) WITH DRY INDOOR COIL AND AIR FILTERS IN PLACE. FOR ALL UNITS ADD:**

- 1 – Wet indoor coil air resistance of selected unit.
  - 2 – Any factory installed options air resistance (heat section, economizer, etc.)
  - 3 – Any field installed accessories air resistance (duct resistance, diffuser, etc.)
- See page 25 for wet coil and option/accessory air resistance data.

**MAXIMUM STATIC PRESSURE WITH GAS HEAT - 2.0 in. w.g.**

Total Air Volume cfm	Total Static Pressure - in. w.g.													
	0.2		0.4		0.6		0.8		1.0		1.2		1.4	
	RPM	Watts	RPM	Watts	RPM	Watts	RPM	Watts	RPM	Watts	RPM	Watts	RPM	Watts
1750	711	188	771	279	836	366	905	453	975	544	1044	640	1109	737
2000	752	242	812	332	876	420	944	510	1011	606	1075	709	1138	812
2250	799	300	860	389	923	479	988	575	1052	678	1113	787	1171	896
2500	853	362	914	453	976	548	1038	650	1097	761	1154	877	1209	990
2750	914	434	974	529	1033	629	1091	739	1146	858	1199	979	1250	1098
3000	980	513	1037	614	1092	720	1146	837	1198	961	1247	1088	1295	1215
3250	1048	598	1101	705	1153	819	1203	941	1251	1071	1298	1206	1343	1343
3500	1116	693	1166	809	1214	931	1261	1060	1307	1198	1351	1341	1395	1489
3750	1185	806	1232	931	1277	1063	1322	1201	1365	1348	1407	1499	1448	1657
4000	1254	937	1299	1072	1341	1214	1383	1363	1424	1518	1464	1679	1503	1844
4250	1324	1089	1366	1234	1406	1386	1445	1545	1484	1708	1522	1876	1559	2046
4500	1395	1262	1433	1417	1471	1579	1508	1745	1544	1913	1581	2084	1616	2256
4750	1465	1455	1501	1619	1536	1787	1571	1957	1606	2128	1641	2299	1675	2470
5000	1534	1666	1568	1834	1602	2004	1635	2174	1668	2345	1701	2514	1735	2682
5250	1603	1887	1635	2055	1667	2224	1699	2392	1731	2559	1763	2724	---	---
5500	1671	2110	1702	2275	1733	2441	1764	2605	---	---	---	---	---	---
5750	1738	2325	1768	2488	---	---	---	---	---	---	---	---	---	---

Total Air Volume cfm	Total Static Pressure - in. w.g.											
	1.6		1.8		2.0		2.2		2.4		2.6	
	RPM	Watts	RPM	Watts	RPM	Watts	RPM	Watts	RPM	Watts	RPM	Watts
1750	1172	833	1231	932	1287	1039	1340	1156	1391	1283	1442	1426
2000	1197	913	1253	1019	1306	1135	1357	1261	1407	1398	1457	1547
2250	1227	1003	1280	1117	1330	1242	1379	1378	1428	1525	1477	1680
2500	1261	1103	1311	1226	1360	1361	1407	1507	1454	1663	1501	1826
2750	1299	1219	1347	1350	1394	1494	1440	1649	1485	1813	1530	1982
3000	1342	1346	1388	1487	1432	1640	1476	1803	1520	1973	1563	2146
3250	1388	1485	1432	1638	1475	1800	1517	1969	1558	2143	1600	2319
3500	1437	1643	1479	1805	1519	1975	1560	2148	1600	2325	1640	2502
3750	1489	1821	1528	1990	1567	2164	1605	2340	1645	2517	1685	2693
4000	1541	2014	1579	2187	1616	2364	1654	2540	1693	2715	1732	2887
4250	1596	2218	1632	2393	1668	2569	1705	2742	1743	2913	---	---
4500	1652	2429	1687	2603	1722	2775	1759	2944	---	---	---	---
4750	1709	2641	1743	2811	1778	2979	---	---	---	---	---	---
5000	1768	2850	---	---	---	---	---	---	---	---	---	---
5250	---	---	---	---	---	---	---	---	---	---	---	---
5500	---	---	---	---	---	---	---	---	---	---	---	---
5750	---	---	---	---	---	---	---	---	---	---	---	---



## BLOWER DATA

### FACTORY INSTALLED BELT DRIVE KIT SPECIFICATIONS

Nominal hp	Maximum hp	Drive Kit Number	RPM Range
2	2.3	1	590 - 890
2	2.3	2	800 - 1105
2	2.3	3	795 - 1195
3	3.45	4	730 - 970
3	3.45	5	940 - 1200
3	3.45	6	1015 - 1300
5	5.75	10	900 - 1135
5	5.75	11	1040 - 1315
5	5.75	12	1125 - 1425

NOTE - Using total air volume and system static pressure requirements determine from blower performance tables rpm and motor output required. Maximum usable output of motors furnished are shown. In Canada, nominal motor output is also maximum usable motor output. If motors of comparable output are used, be sure to keep within the service factor limitations outlined on the motor nameplate.

NOTE – Units equipped with MSAV® (Multi-Stage Air Volume) option are limited to a motor service factor of 1.0.

### POWER EXHAUST FAN PERFORMANCE

Return Air System Static Pressure	Air Volume Exhausted
in. w.g.	cfm
0	3175
0.05	2955
0.10	2685
0.15	2410
0.20	2165
0.25	1920
0.30	1420
0.35	1200

### FACTORY INSTALLED OPTIONS/FIELD INSTALLED ACCESSORY AIR RESISTANCE - in. w.g.

Air Volume cfm	Wet Indoor Coil	Gas Heat Exchanger			Economizer	Filters		Return Air Adaptor Plate
	092,102,122	Standard Heat	Medium Heat	High Heat		MERV 8	MERV 13	
1750	0.04	0.06	0.02	0.02	0.05	0.01	0.03	0.00
2000	0.05	0.07	0.05	0.06	0.06	0.01	0.03	0.00
2250	0.06	0.07	0.07	0.08	0.08	0.01	0.04	0.00
2500	0.07	0.09	0.10	0.11	0.11	0.01	0.05	0.00
2750	0.08	0.09	0.11	0.12	0.12	0.02	0.05	0.00
3000	0.10	0.11	0.12	0.13	0.13	0.02	0.06	0.02
3250	0.11	0.12	0.15	0.16	0.15	0.02	0.06	0.02
3500	0.12	0.12	0.16	0.17	0.15	0.03	0.07	0.04
3750	0.14	0.14	0.19	0.20	0.15	0.03	0.08	0.07
4000	0.15	0.14	0.21	0.22	0.19	0.04	0.08	0.09
4250	0.17	0.14	0.24	0.28	0.19	0.04	0.09	0.11
4500	0.19	0.15	0.26	0.32	0.22	0.04	0.09	0.12
4750	0.20	0.16	0.29	0.37	0.25	0.05	0.10	0.16
5000	0.22	0.16	0.34	0.43	0.29	0.06	0.10	0.18
5250	0.24	0.16	0.37	0.47	0.32	0.06	0.11	0.19
5500	0.25	0.18	0.44	0.54	0.34	0.07	0.12	0.22
5750	0.27	0.19	0.49	0.59	0.45	0.07	0.12	0.25
6000	0.29	0.20	0.54	0.64	0.52	0.08	0.13	0.27

## BLOWER DATA

### CEILING DIFFUSERS AIR RESISTANCE - in. w.g.

Unit Size	RTD11 Step-Down Diffuser			FD11 Flush Diffuser	
	Air Volume cfm	2 Ends Open	1 Side, 2 Ends Open		All Ends & Sides Open
092 Models	2400	0.21	0.18	0.15	0.14
	2600	0.24	0.21	0.18	0.17
	2800	0.27	0.24	0.21	0.20
	3000	0.32	0.29	0.25	0.25
	3200	0.41	0.37	0.32	0.31
	3400	0.50	0.45	0.39	0.37
	3600	0.61	0.54	0.48	0.44
	3800	0.73	0.63	0.57	0.51
102 & 122 Models	3600	0.36	0.28	0.23	0.15
	3800	0.40	0.32	0.26	0.18
	4000	0.44	0.36	0.29	0.21
	4200	0.49	0.40	0.33	0.24
	4400	0.54	0.44	0.37	0.27
	4600	0.60	0.49	0.42	0.31
	4800	0.65	0.53	0.46	0.35
	5000	0.69	0.58	0.50	0.39
	5200	0.75	0.62	0.54	0.43

### CEILING DIFFUSER AIR THROW DATA

Model No.	Air Volume	<sup>1</sup> Effective Throw Range	
		RTD11 Step-Down	FD11 Flush
	cfm	ft.	ft.
092 Models	2600	24 - 29	19 - 24
	2800	25 - 30	20 - 28
	3000	27 - 33	21 - 29
	3200	28 - 35	22 - 29
	3400	30 - 37	22 - 30
102 & 122 Models	3600	25 - 33	22 - 29
	3800	27 - 35	22 - 30
	4000	29 - 37	24 - 33
	4200	32 - 40	26 - 35
	4400	34 - 42	28 - 37

<sup>1</sup> Throw is the horizontal or vertical distance an air stream travels on leaving the outlet or diffuser before the maximum velocity is reduced to 50 ft. per minute. Four sides open.

**ELECTRICAL DATA****BELT DRIVE - 7.5 TON**

Model No.		KDB092H4								
<sup>1</sup> Voltage - 60hz		208/230V - 3 Ph			460V - 3 Ph			575V - 3 Ph		
Compressor 1	Rated Load Amps	13.1			6.1			4.4		
	Locked Rotor Amps	83.1			41			33		
Compressor 2	Rated Load Amps	13.1			6.1			4.4		
	Locked Rotor Amps	83.1			41			33		
Outdoor Fan Motors (2)	Full Load Amps	2.8			1.4			1.1		
	(total)	(5.6)			(2.8)			(2.2)		
Power Exhaust (1) 0.33 HP	Full Load Amps	2.4			1.3			1		
Service Outlet 115V GFI (amps)		15			15			20		
Indoor Blower Motor	Horsepower	2	3	5	2	3	5	2	3	5
	Full Load Amps	7.5	10.6	16.7	3.4	4.8	7.6	2.7	3.9	6.1
<sup>2</sup> Maximum Overcurrent Protection	Unit Only	50	50	60	25	25	30	15	20	20
	With (1) 0.33 HP Power Exhaust	50	60	70	25	25	30	20	20	25
<sup>3</sup> Minimum Circuit Ampacity	Unit Only	43	46	53	20	22	25	15	16	19
	With (1) 0.33 HP Power Exhaust	45	49	56	22	23	26	16	17	20

**ELECTRICAL ACCESSORIES**

Disconnect	54W56	54W56	54W56
------------	-------	-------	-------

NOTE - All units have a minimum Short Circuit Current Rating (SCCR) of 5000 amps.

<sup>1</sup> Extremes of operating range are plus and minus 10% of line voltage.

<sup>2</sup> HACR type breaker or fuse.

<sup>3</sup> Refer to National or Canadian Electrical Code manual to determine wire, fuse and disconnect size requirements.

**ELECTRICAL DATA****BELT DRIVE - 8.5 TON**

Model No.		KDB102H4								
<sup>1</sup> Voltage - 60hz		208/230V - 3 Ph			460V - 3 Ph			575V - 3 Ph		
Compressor 1	Rated Load Amps	14.5			6.3			6		
	Locked Rotor Amps	98			55			41		
Compressor 2	Rated Load Amps	14.5			6.3			6		
	Locked Rotor Amps	98			55			41		
Outdoor Fan Motors (2)	Full Load Amps	2.8			1.4			1.1		
	(total)	(5.6)			(2.8)			(2.2)		
Power Exhaust (1) 0.33 HP	Full Load Amps	2.4			1.3			1		
Service Outlet 115V GFI (amps)		15			15			20		
Indoor Blower Motor	Horsepower	2	3	5	2	3	5	2	3	5
	Full Load Amps	7.5	10.6	16.7	3.4	4.8	7.6	2.7	3.9	6.1
<sup>2</sup> Maximum Overcurrent Protection	Unit Only	60	60	70	25	25	30	20	25	25
	With (1) 0.33 HP Power Exhaust	60	60	70	25	25	30	25	25	25
<sup>3</sup> Minimum Circuit Ampacity	Unit Only	46	49	56	21	22	25	19	20	22
	With (1) 0.33 HP Power Exhaust	49	52	58	22	24	27	20	21	23

**ELECTRICAL ACCESSORIES**

Disconnect	54W56	54W56	54W56
------------	-------	-------	-------

NOTE - All units have a minimum Short Circuit Current Rating (SCCR) of 5000 amps.

<sup>1</sup> Extremes of operating range are plus and minus 10% of line voltage.

<sup>2</sup> HACR type breaker or fuse.

<sup>3</sup> Refer to National or Canadian Electrical Code manual to determine wire, fuse and disconnect size requirements.

**ELECTRICAL DATA****DIRECT DRIVE - 10 TON**

Model No.		KDB122H4		
<sup>1</sup> Voltage - 60hz		208/230V - 3 Ph	460V - 3 Ph	575V - 3 Ph
Compressor 1	Rated Load Amps	15.6	7.8	5.8
	Locked Rotor Amps	110	52	38.9
Compressor 2	Rated Load Amps	15.6	7.8	5.8
	Locked Rotor Amps	110	52	38.9
Outdoor Fan Motors (3)	Full Load Amps (total)	2.8 (8.4)	1.4 (4.2)	1.1 (3.3)
Power Exhaust (1) 0.33 HP	Full Load Amps	2.4	1.3	1
Service Outlet 115V GFI (amps)		15	15	20
Indoor Blower Motor	Horsepower	3.75	3.75	3.75
	Full Load Amps	8.8	4.3	3.4
<sup>2</sup> Maximum Overcurrent Protection	Unit Only	60	30	25
	With (1) 0.33 HP Power Exhaust	70	35	25
<sup>3</sup> Minimum Circuit Ampacity	Unit Only	53	27	20
	With (1) 0.33 HP Power Exhaust	60	30	23

**ELECTRICAL ACCESSORIES**

<b>Disconnect</b>	<b>54W56</b>	<b>54W56</b>	<b>54W56</b>
-------------------	--------------	--------------	--------------

NOTE - All units have a minimum Short Circuit Current Rating (SCCR) of 5000 amps.

<sup>1</sup> Extremes of operating range are plus and minus 10% of line voltage.

<sup>2</sup> HACR type breaker or fuse.

<sup>3</sup> Refer to National or Canadian Electrical Code manual to determine wire, fuse and disconnect size requirements.

## UNIT CLEARANCES

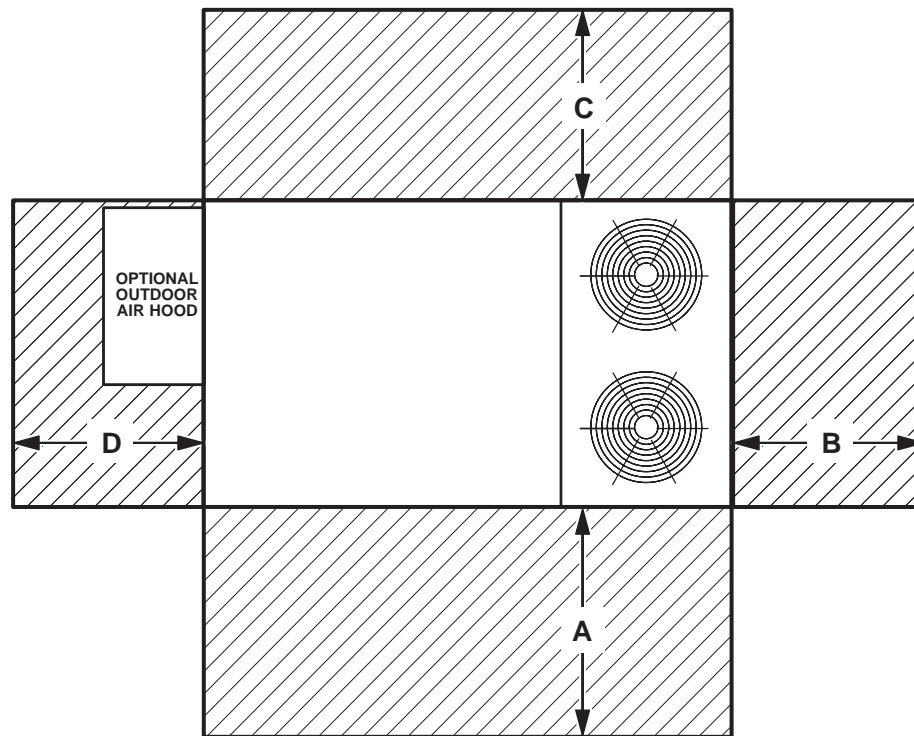

<sup>1</sup> Unit Clearance	A		B		C		D		Top Clearance
	in.	mm	in.	mm	in.	mm	in.	mm	
<b>Service Clearance</b>	60	1524	36	914	36	914	60	1524	Unobstructed
<b>Minimum Operation Clearance</b>	36	914	36	914	36	914	36	914	

NOTE - Entire perimeter of unit base requires support when elevated above the mounting surface.

<sup>1</sup> **Service Clearance** - Required for removal of serviceable parts.

**Minimum Operation Clearance** - Required clearance for proper unit operation.

## OUTDOOR SOUND DATA

Unit Model Number	Octave Band Sound Power Levels dBA, re 10 <sup>-12</sup> Watts Center Frequency - Hz							<sup>1</sup> Sound Rating Number (dBA)
	125	250	500	1000	2000	4000	8000	
KDB092, 102	72	75	76	73	67	60	50	86
KDB122	73	74	75	72	66	60	50	85

Note - The octave sound power data does not include tonal corrections.

<sup>1</sup> Sound Rating Number according to AHRI Standard 270-95 or AHRI Standard 370-2001 (includes pure tone penalty). Sound Rating Number is the overall A-Weighted Sound Power Level, (L<sub>wa</sub>), dB (100 Hz to 10,000 Hz).

**WEIGHT DATA**

Model Number	Net		Shipping	
	lbs.	kg	lbs.	kg
KDB092H Base Unit	1121	509	1206	548
KDB092H Max. Unit	1264	574	1349	612
KDB102H Base Unit	1123	510	1208	548
KDB102H Max. Unit	1266	575	1351	613
KDB122H Base Unit	1264	574	1349	612
KDB122H Max. Unit	1407	639	1492	677

**OPTIONS / ACCESSORIES**

Model Number	Shipping Weight	
	lbs.	kg

**ECONOMIZER / OUTDOOR AIR / EXHAUST**

<b>Economizer</b>		
Economizer Dampers	60	27
Barometric Relief Dampers (downflow)	8	4
Barometric Relief Damper Hood (downflow)	25	11
Outdoor Air Hood (downflow)	23	10
<b>Outdoor Air Dampers</b>		
Outdoor Air Damper Section - Automatic	51	23
Outdoor Air Damper Section - Manual	39	18
<b>Power Exhaust</b>	31	14

**GAS HEAT EXCHANGER (NET WEIGHT)**

Medium Heat (adder over standard heat)	9	4
High Heat (adder over standard heat)	32	15

**MSAV (MULTI-STAGE AIR VOLUME) SUPPLY AIR BLOWER OPTION**

Variable Frequency Drive (VFD) and associated components	10	5
--	----	---

**ROOF CURBS**

<b>Hybrid Roof Curbs, Downflow</b>		
8 in. height	60	27
14 in. height	85	39
18 in. height	100	45
24 in. height	125	57

**Adjustable Pitch Curb, Downflow**

14 in. height	191	82
---------------	-----	----

**PACKAGING**

LTL Packaging (less than truck load)	105	48
--------------------------------------	-----	----

**CEILING DIFFUSERS**

<b>Step-Down</b>		
RTD11-95S	118	54
RTD11-135S	135	61
<b>Flush</b>		
FD11-95S	118	54
FD11-135S	135	61
<b>Transitions</b>		
C1DIFF30B-1	30	14
C1DIFF31B-1	32	15

**DIMENSIONS - UNIT**

**092 | 102 MODELS**

Model No.	CORNER WEIGHTS														CENTER OF GRAVITY									
	AA				BB				CC				DD				EE				FF			
	Base		Max.		Base		Max.		Base		Max.		Base		Max.		Base		Max.		Base		Max.	
	lbs.	kg	lbs.	kg	lbs.	kg	lbs.	kg	lbs.	kg	lbs.	kg	lbs.	kg	in.	mm	in.	mm	in.	mm	in.	mm	in.	mm
KDB092	296	134	334	152	248	112	279	127	260	118	293	133	318	144	358	163	44	1118	43	1092	27	686	28	711
KDB102	297	135	334	152	248	113	280	127	260	118	293	133	318	144	359	163	44	1118	43	1092	27	686	28	711

Base Unit - The unit with NO OPTIONS.

Max. Unit - The unit with ALL OPTIONS Installed (Economizer, etc.).

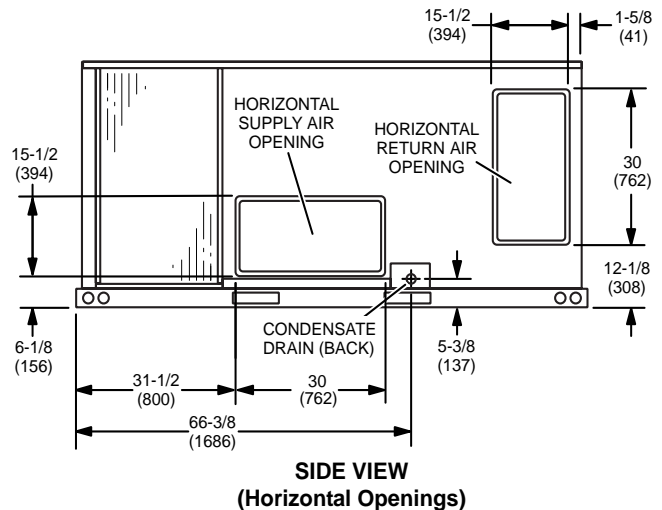
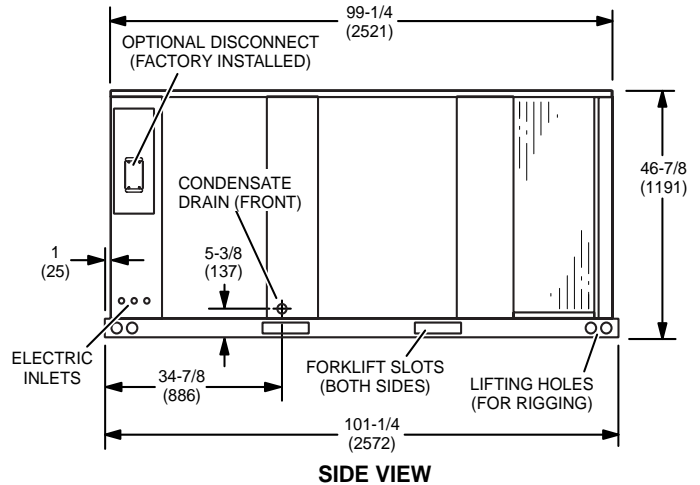
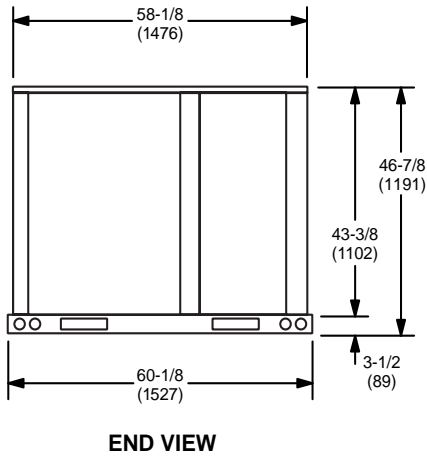
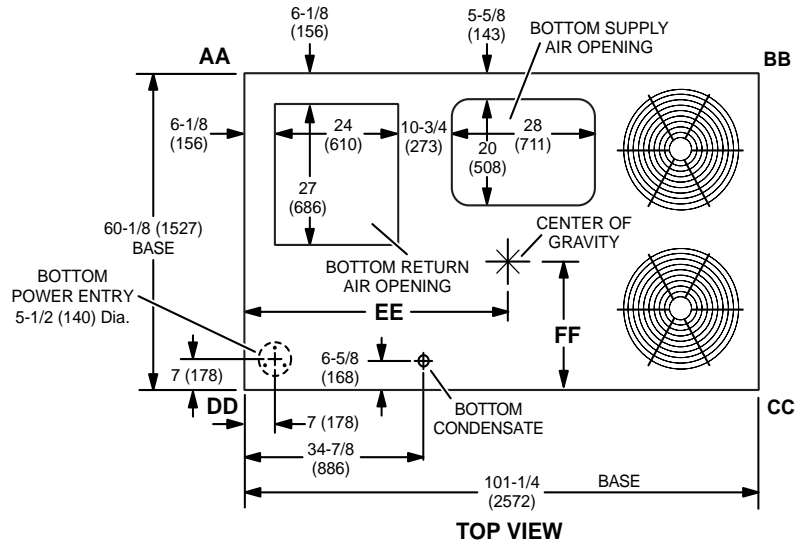

**DIMENSIONS - UNIT**

**122 MODEL**

Model No.	CORNER WEIGHTS														CENTER OF GRAVITY									
	AA				BB				CC				DD				EE				FF			
	Base		Max.		Base		Max.		Base		Max.		Base		Max.		Base		Max.		Base		Max.	
	lbs.	kg	lbs.	kg	lbs.	kg	lbs.	kg	lbs.	kg	lbs.	kg	lbs.	kg	in.	mm	in.	mm	in.	mm	in.	mm	in.	mm
KDB122	328	149	366	166	284	129	316	144	299	136	333	151	352	160	392	178	56.5	1435	55.5	1010	25.5	648	26.5	673

Base Unit - The unit with NO OPTIONS.

Max. Unit - The unit with ALL OPTIONS Installed (Economizer, etc.).

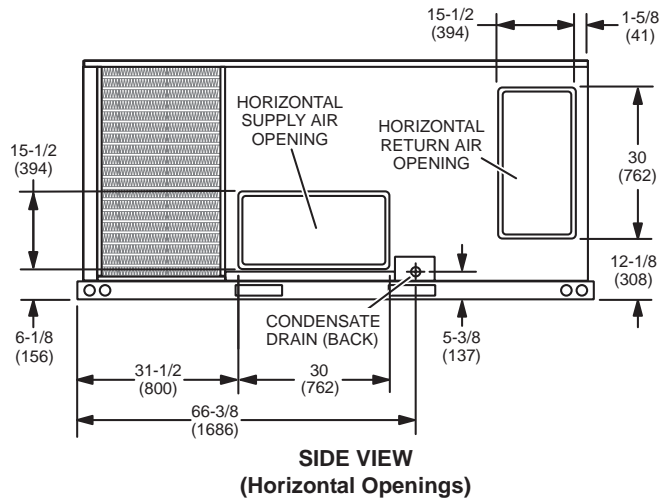
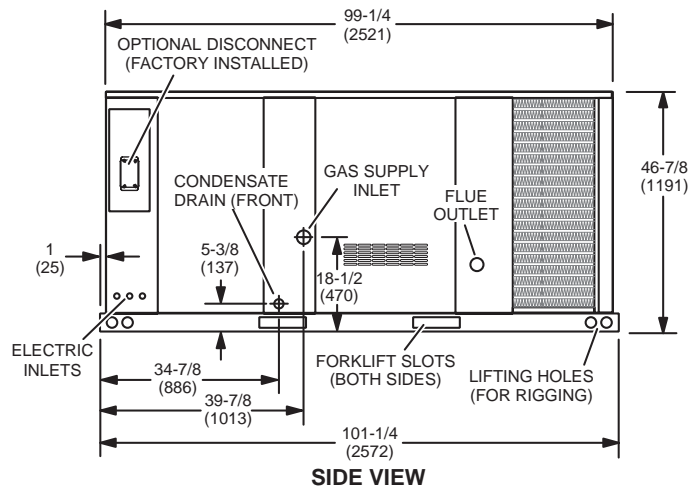
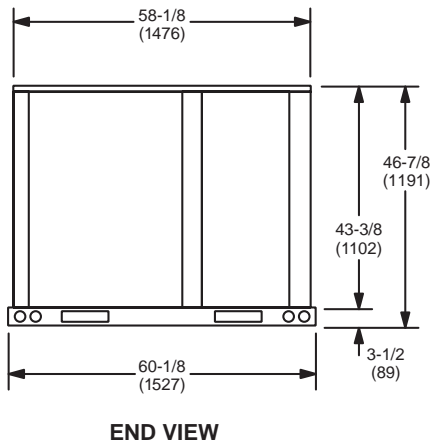
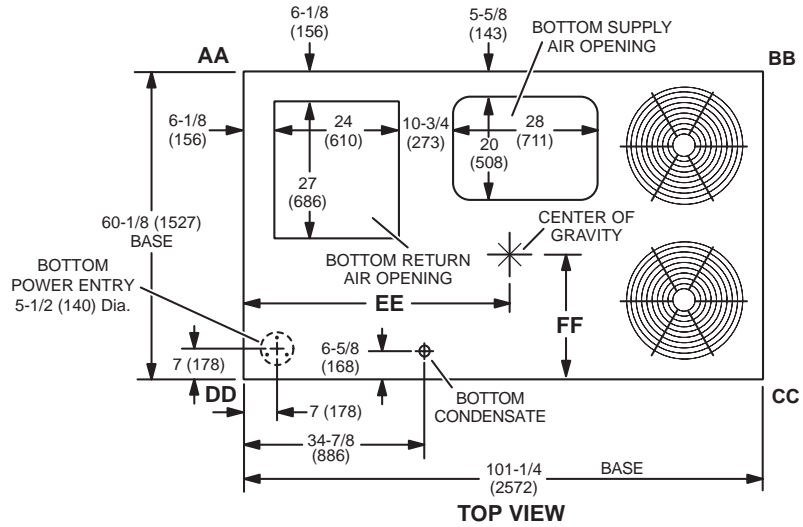



**UNIT ON CURB LOCATION - KDB122**

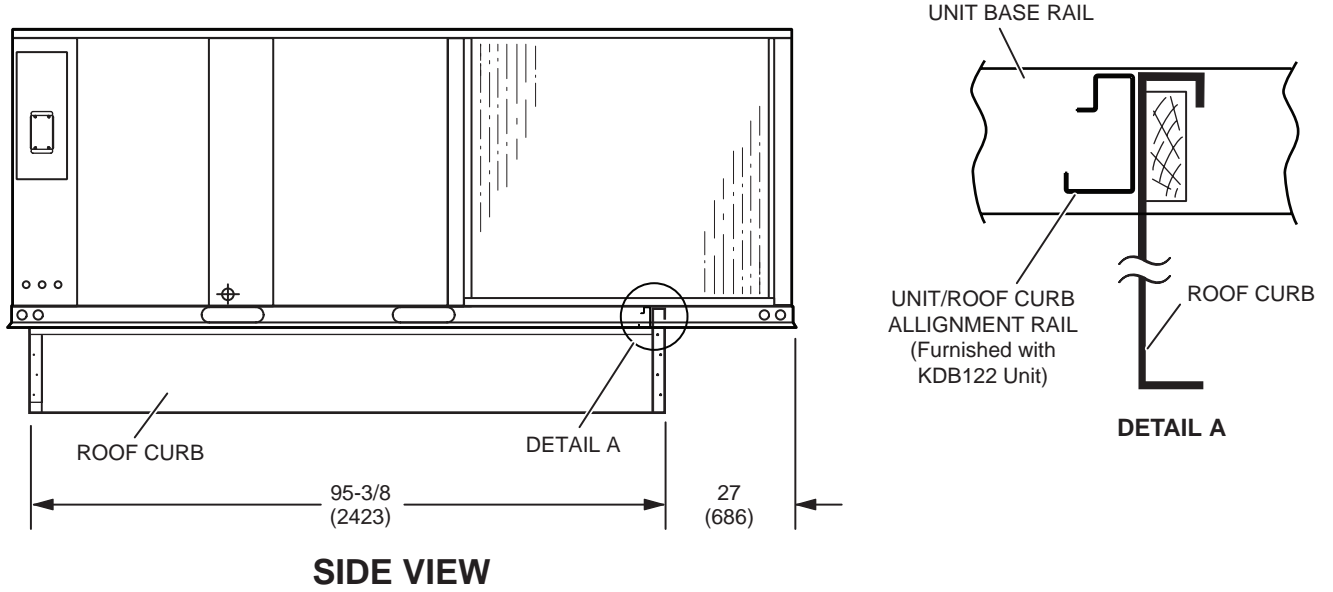

**OUTDOOR AIR HOOD DETAIL**

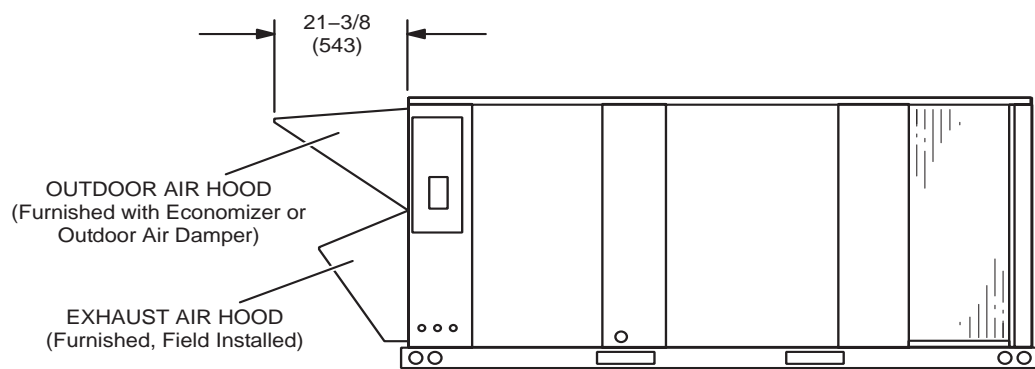

## DIMENSIONS - ACCESSORIES

### HORIZONTAL ECONOMIZER APPLICATION

(With Furnished Barometric Relief Dampers and Optional Horizontal Discharge Kit - Required)

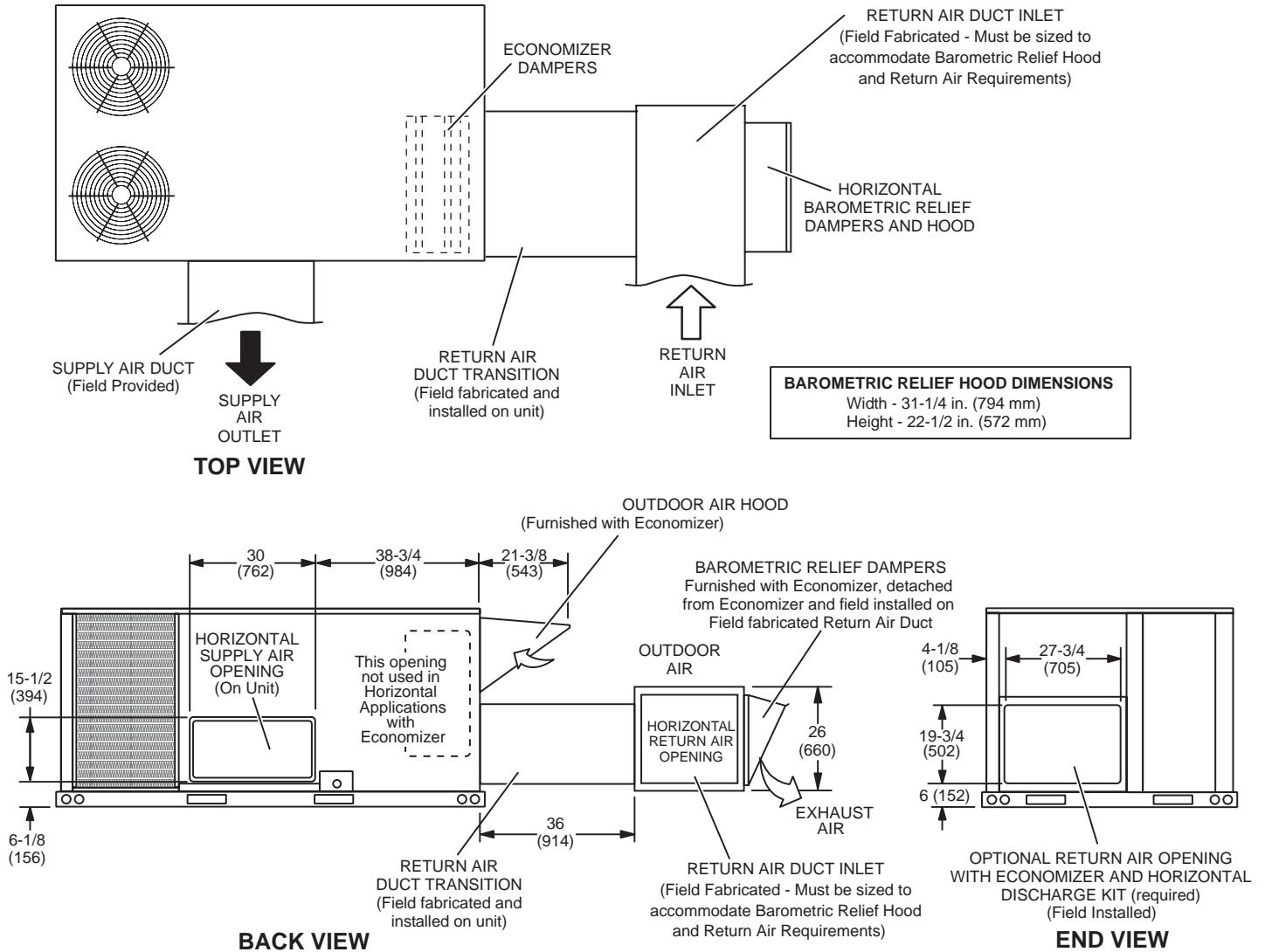

NOTE - Return Air Duct and Transition must be supported.

### BAROMETRIC RELIEF DAMPERS (Furnished with Economizer)

(Field installed in horizontal return air duct adjacent to unit)

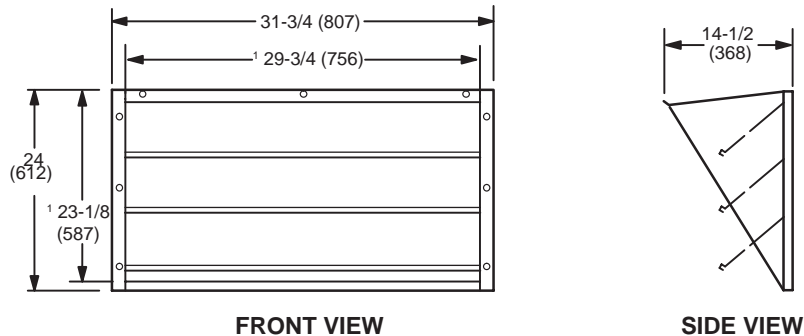

<sup>1</sup> NOTE - Opening size required in return air duct.

## DIMENSIONS - ACCESSORIES

### HORIZONTAL ECONOMIZER APPLICATION

(with Optional Low Profile Horizontal Barometric Relief Dampers and Horizontal Discharge Kit - Required)

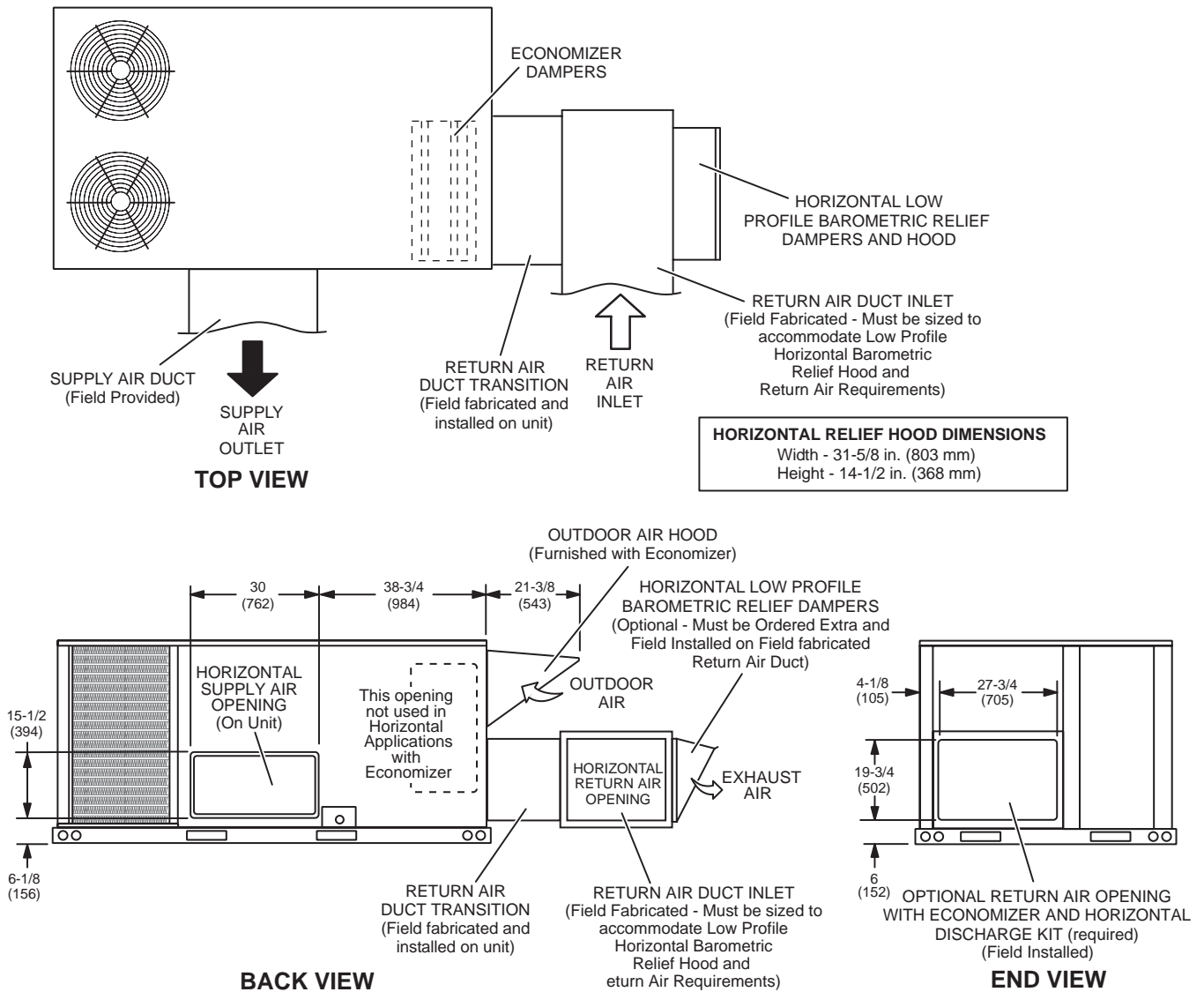

**NOTE** - Return Air Duct and Transition must be supported.

### HORIZONTAL LOW PROFILE BAROMETRIC RELIEF DAMPERS (Field installed in horizontal return air duct adjacent to unit)

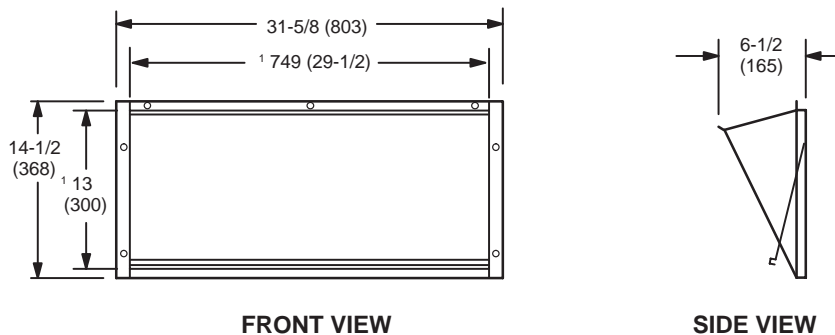

<sup>1</sup> NOTE - Opening size required in return air duct.

# DIMENSIONS - ACCESSORIES

## HYBRID ROOF CURBS - DOUBLE DUCT OPENING

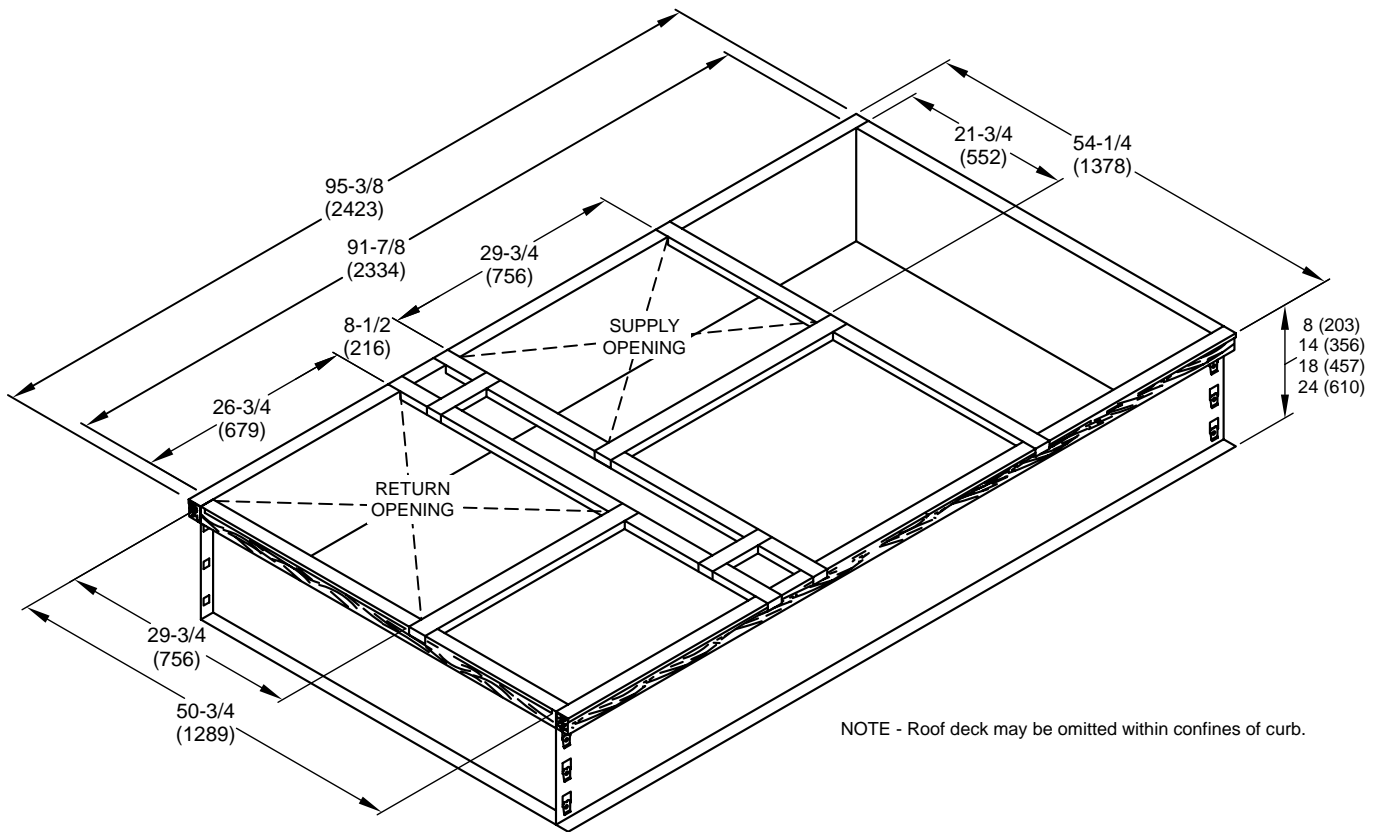

**TYPICAL FLASHING DETAIL FOR ROOF CURB**

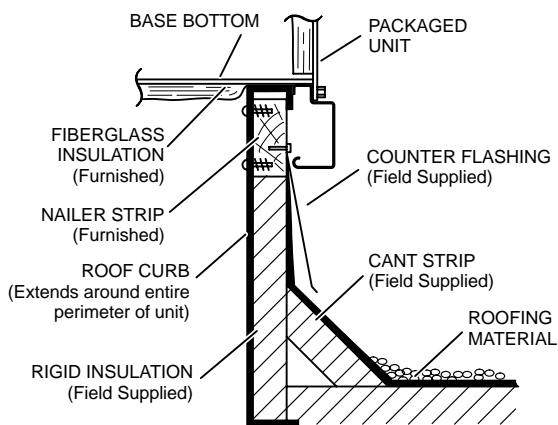

**DETAIL ROOF CURB**

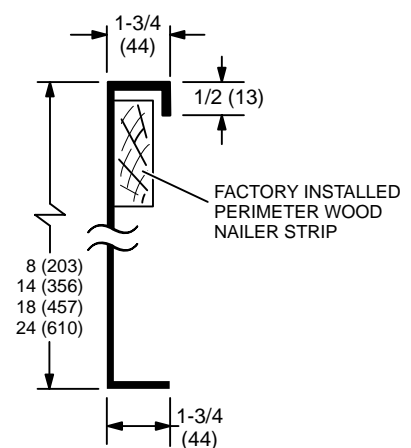

# DIMENSIONS - ACCESSORIES

## ADJUSTABLE PITCH CURBS - DOUBLE DUCT OPENING

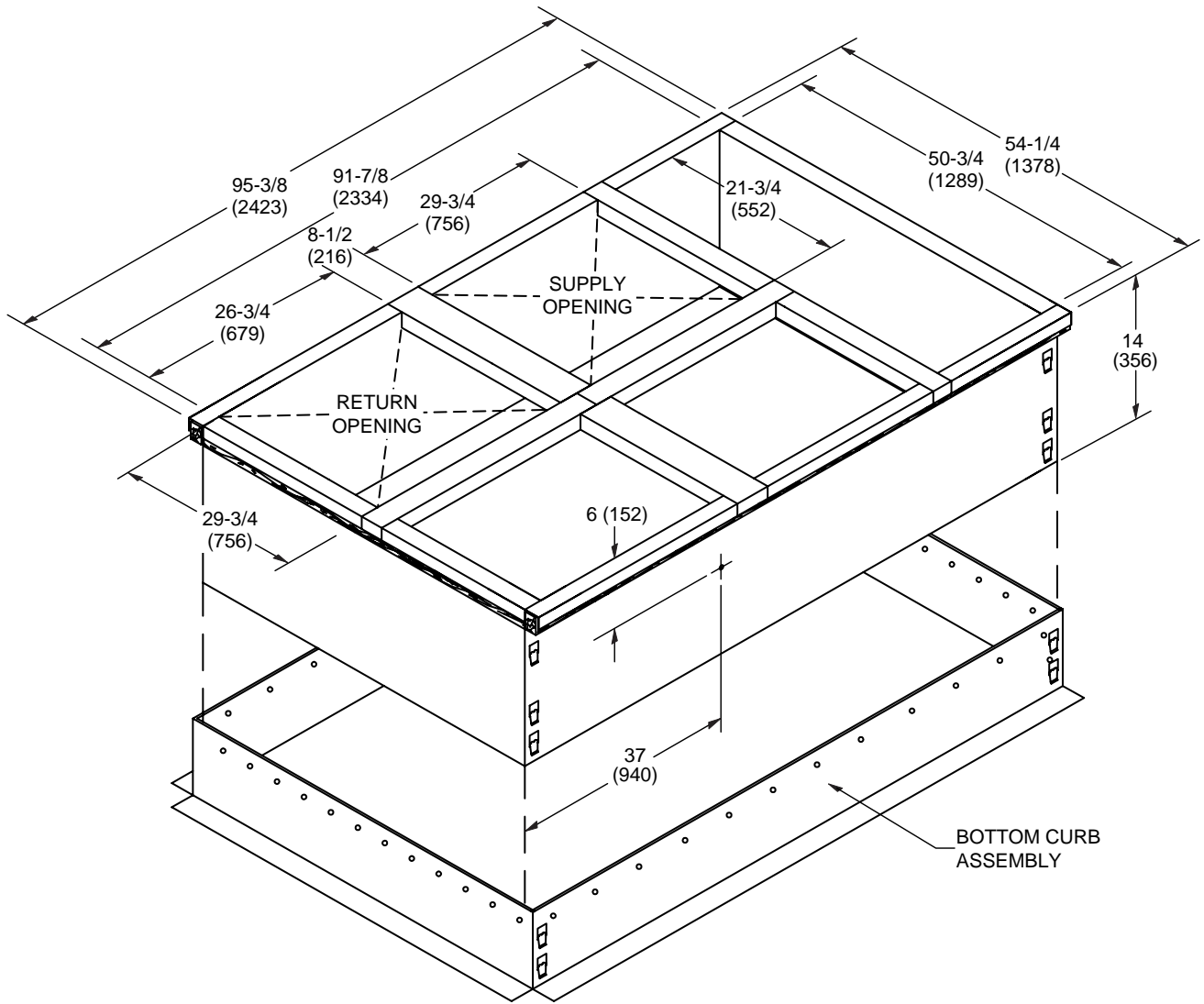

NOTE - Maximum slope pitch is 3/4 in. per 1 foot (19 mm per 305 mm) in any one direction.

### TYPICAL FLASHING DETAIL FOR ROOF CURB

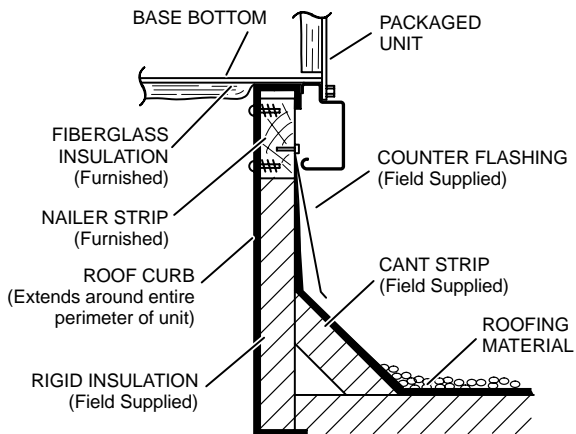

### DETAIL ROOF CURB

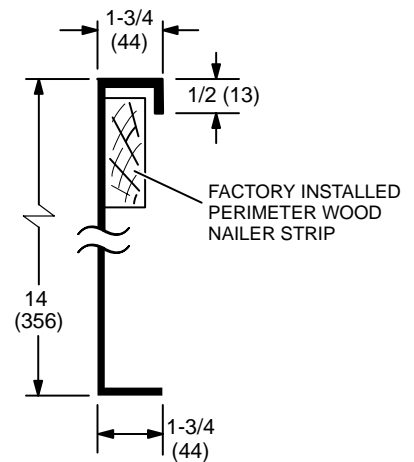

# DIMENSIONS - ACCESSORIES

## ROOF CURBS WITH SUPPLY & RETURN AIR TRANSITIONS FOR CEILING DIFFUSERS

**C1DIFF30B-1 ROUND TRANSITIONS**  
(for 092 models)

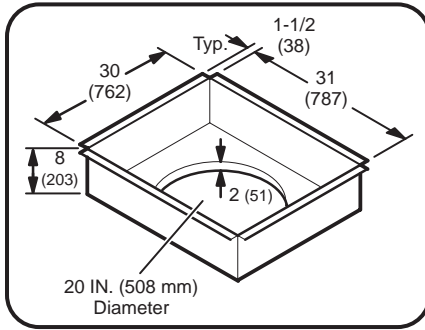

**C1DIFF31B-1 RECTANGULAR TRANSITIONS**  
(for 102 and 122 models)

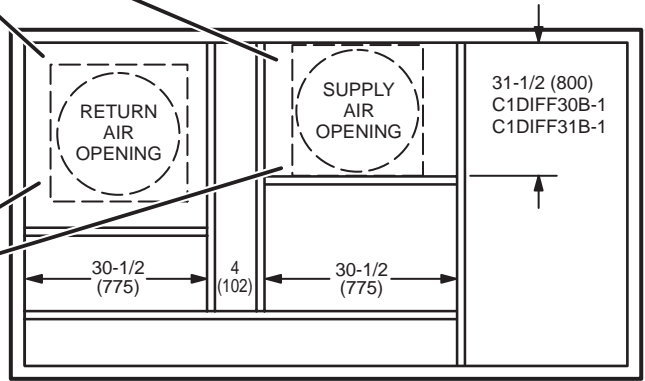
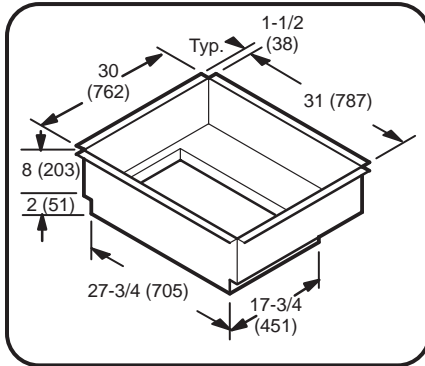

**TOP VIEW**

## DIMENSIONS - ACCESSORIES

### COMBINATION CEILING SUPPLY AND RETURN DIFFUSERS

#### STEP-DOWN CEILING DIFFUSER

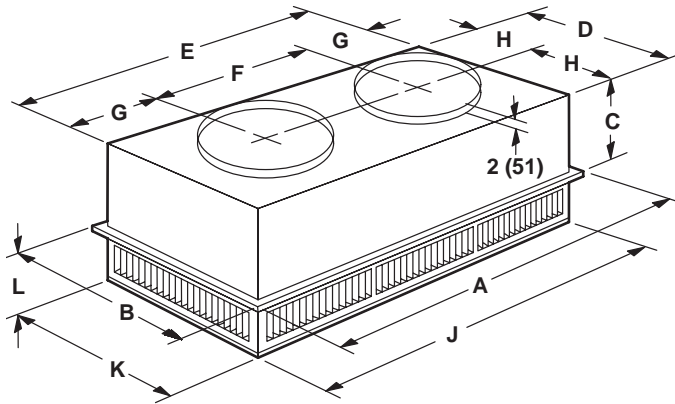

#### FLUSH CEILING DIFFUSER

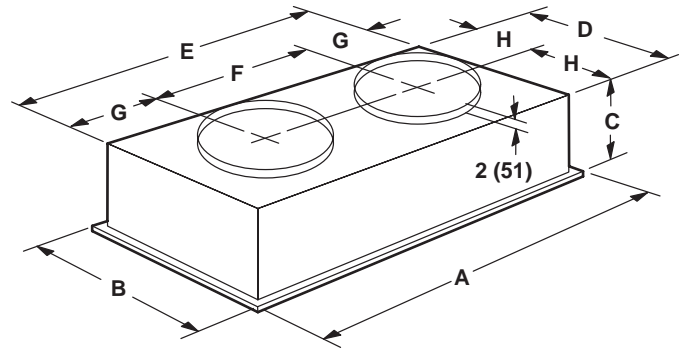

Model Number		RTD11-95S
A	in.	47-5/8
	mm	1159
B	in.	29-5/8
	mm	752
C	in.	14-3/8
	mm	365
D	in.	27-1/2
	mm	699
E	in.	45-1/2
	mm	1158
F	in.	22-1/2
	mm	572
G	in.	11-1/2
	mm	292
H	in.	13-3/4
	mm	349
J	in.	45-1/2
	mm	1156
K	in.	27-1/2
	mm	699
L	in.	8-1/8
	mm	206
Duct Size	in.	20 round
	mm	508 round

Model Number		FD11-95S
A	in.	47-5/8
	mm	1159
B	in.	29-5/8
	mm	752
C	in.	16-5/8
	mm	422
D	in.	27
	mm	686
E	in.	45
	mm	1143
F	in.	22-1/2
	mm	572
G	in.	11-1/4
	mm	286
H	in.	13-1/2
	mm	343
Duct Size	in.	20 round
	mm	508 round

## DIMENSIONS - ACCESSORIES

### COMBINATION CEILING SUPPLY AND RETURN DIFFUSERS

#### STEP-DOWN CEILING DIFFUSER

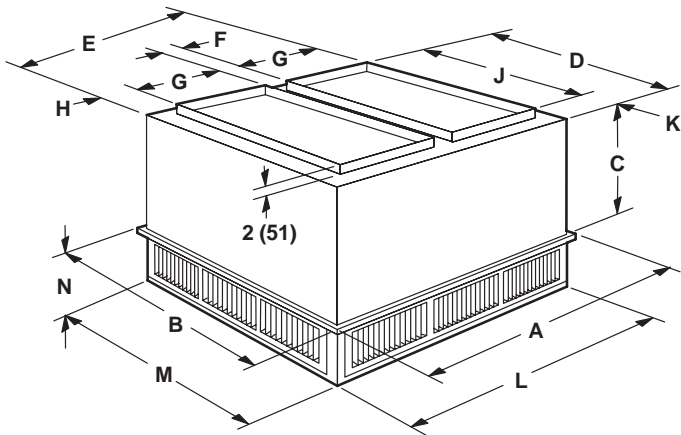

#### FLUSH CEILING DIFFUSER

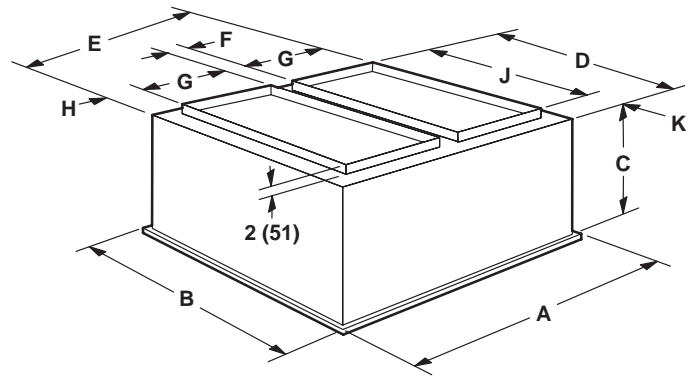

Model Number		RTD11-135S
A	in.	47-5/8
	mm	1210
B	in.	35-5/8
	mm	905
C	in.	20-5/8
	mm	524
D	in.	33-1/2
	mm	851
E	in.	45-1/2
	mm	1156
F	in.	4-1/2
	mm	114
G	in.	18
	mm	457
H	in.	2-1/2
	mm	64
J	in.	28
	mm	711
K	in.	2-3/4
	mm	70
L	in.	45-1/2
	mm	1156
M	in.	33-1/2
	mm	851
N	in.	9-1/8
	mm	232
Duct Size	in.	18 x 28
	mm	457 x 711

Model Number		FD11-135S
A	in.	47-5/8
	mm	1210
B	in.	35-5/8
	mm	905
C	in.	23-1/4
	mm	591
D	in.	33
	mm	838
E	in.	45
	mm	1143
F	in.	4-1/2
	mm	114
G	in.	18
	mm	457
H	in.	2-1/4
	mm	57
J	in.	28
	mm	711
K	in.	2-1/2
	mm	64
Duct Size	in.	18 x 28
	mm	457 x 711









## REVISIONS

Section	Description
Specifications	Heating Performance updated for KDB092H4B.



Visit us at [www.lennox.com](http://www.lennox.com)

For the latest technical information, [www.lennoxcommercial.com](http://www.lennoxcommercial.com)

Contact us at 1-800-4-LENNOX

NOTE - Due to Lennox' ongoing commitment to quality, Specifications, Ratings and Dimensions subject to change without notice and without incurring liability. Improper installation, adjustment, alteration, service or maintenance can cause property damage or personal injury. Installation and service must be performed by a qualified installer and servicing agency.

©2020 Lennox Industries, Inc.