



KHA

Landmark® Rooftop Units
Standard Efficiency - 60 Hz

**COMMERCIAL
PRODUCT SPECIFICATIONS**

Bulletin No. 210554
March 2011
Supersedes April 2019



LANDMARK®
Performance Marked by Flexibility™



**ASHRAE 90.1
COMPLIANT**

15 and 20 Tons
Net Cooling Capacity - 174,000 to 218,000 Btuh
Optional Electric Heat - 15 to 90 kW

MODEL NUMBER IDENTIFICATION

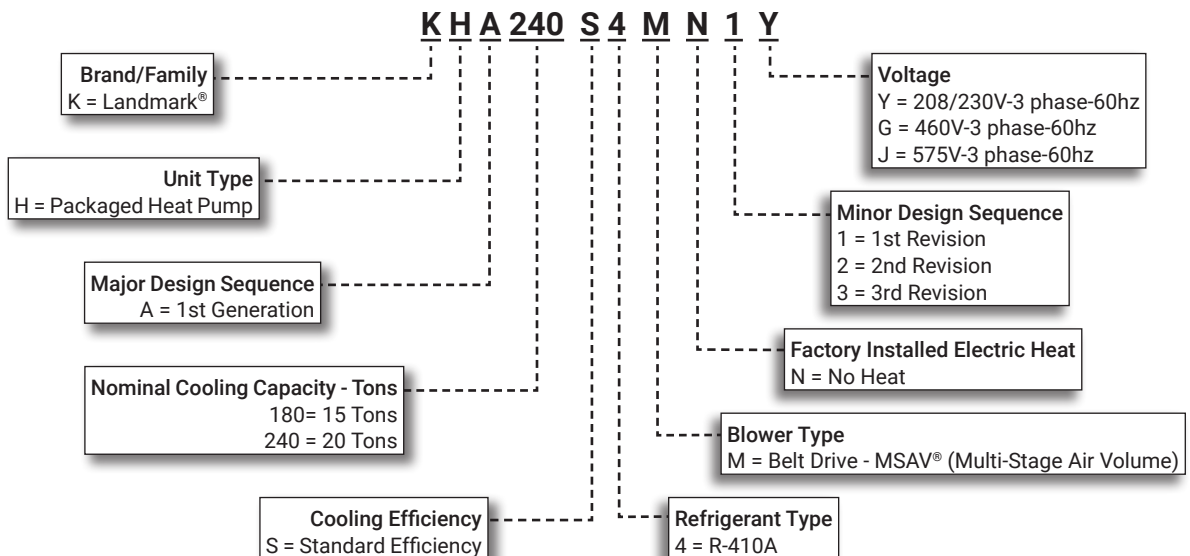

FEATURE HIGHLIGHTS

Landmark® rooftop units from Lennox® are the new standard for reliable, efficient rooftop units built for long-lasting performance that can significantly improve indoor environments.

1. Scroll Compressors
2. Check/Thermal Expansion Valves
3. Filter/Driers
4. Reversing Valves
5. Copper Tube Outdoor Coil
6. Outdoor Coil Fan Motors
7. Heavy Gauge Steel Cabinet
8. Supply Air Blower
9. Unit Control
10. Disconnect Switch (option)
11. Electric Heat (option)
12. Air Filters
13. Economizer (option)
14. Barometric Relief Dampers (option)
15. Power Exhaust (option)

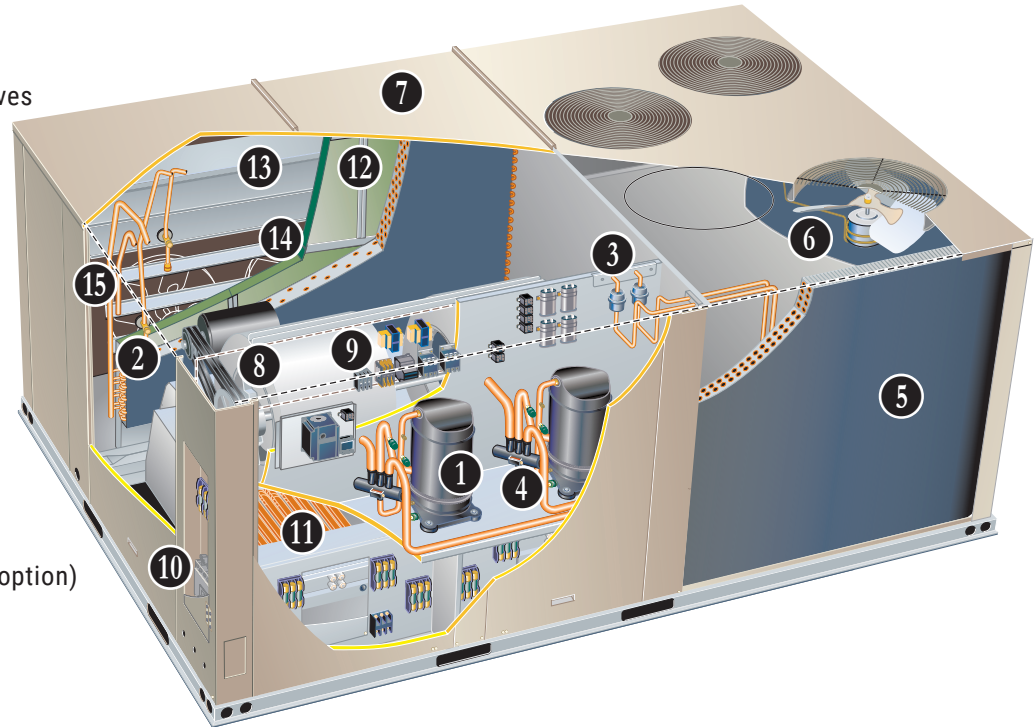

CONTENTS

Approvals And Warranty	3
Blower Data	16
Dimensions - Accessories	24
Dimensions - Unit	23
Electrical/Electric Heat Data	19
Electric Heat Capacities	21
Features And Benefits	3
Model Number Identification.	1
Optional Conventional Temperature Control Systems	9
Options / Accessories	10
Outdoor Sound Data	21
Specifications	13
Unit Clearances	21
Weight Data	22

APPROVALS AND WARRANTY

APPROVALS

- AHRI Standard 340/360 certified
- ETL listed
- CSA certified energy ratings
- Unit and components ETL, NEC and CEC bonded for grounding to meet safety standards for servicing
- All models are ASHRAE 90.1-2010 energy efficiency compliant and meet or exceed requirements of Section 6.8
- All models meet California Code of Regulations, Title 24 and ASHRAE 90.1-2010 Section 6.4.3.10 requirements for staged airflow
- ISO 9001 Registered Manufacturing Quality System

WARRANTY

- Compressors - Limited five years
- High Performance Economizers (optional) - Limited five years
- All other covered components - Limited one year

FEATURES AND BENEFITS

COOLING / HEATING SYSTEM

- Designed to maximize sensible and latent cooling performance at design conditions
- System can operate from 30°F to 125°F without any additional controls

R-410A Refrigerant

- Non-chlorine based
- Ozone friendly

1 Scroll Compressors

- Scroll compressors for high performance, reliability and quiet operation
- Resiliently mounted on rubber grommets for quiet operation

Compressor Crankcase Heaters

- Protects against refrigerant migration that can occur during low ambient operation

2 Check/Thermal Expansion Valves

- Assures optimal performance throughout the application range
- Removable element head

3 Filter/Driers

- High capacity bi-flow filter/drier protects the system from dirt and moisture

High Pressure Switches

- Protects the compressor from overload conditions
- Auto-reset

4 Reversing Valves

- 4-way interchange reversing valve effects a rapid change in direction of refrigerant flow resulting in quick changeover from cooling to heating and vice versa

Freezestats

- Protects the indoor coil from damaging ice build-up due to conditions such as low/no airflow, or low refrigerant charge

5 Coil Construction

- Copper tube construction
- Enhanced rippled-edge aluminum fins
- Flared shoulder tubing connections
- Silver soldered construction
- Factory leak tested
- Two independent formed outdoor coils allow separation for cleaning
- Cross row circuiting of indoor coil with rifled copper tubing optimizes both sensible and latent cooling capacity

Condensate Drain Pan

- Plastic pan, sloped to meet drainage requirements of ASHRAE 62.1
- Side or bottom drain connections

6 Outdoor Coil Fan Motors

- Thermal overload protected
- Totally enclosed
- Permanently lubricated ball bearings
- Shaft up
- Wire basket mount

Outdoor Coil Fans

- PVC coated fan guards furnished

Required Selections

Cooling Capacity

- Specify nominal cooling capacity

FEATURES AND BENEFITS

COOLING / HEATING SYSTEM (continued)

Options/Accessories

Field Installed

Condensate Drain Trap

- Available in copper or PVC

Drain Pan Overflow Switch

- Monitors condensate level in drain pan, shuts down unit if drain becomes clogged

Low Ambient Kit (0°F)

- Cycles the outdoor fan while allowing compressor operation in the cooling cycle
- Intermittent fan operation allows the system to operate without icing the indoor coil and losing capacity
- Designed for use in ambient temperatures no lower than 0°F

CABINET

7 Construction

- Heavy-gauge steel
- Two-layer enamel paint finish
- Full perimeter heavy-gauge galvanized steel base rail
- Base rails have rigging holes
- Three sides of the base rail have fork slots
- Raised edges around duct and power entry openings in the bottom of the unit for water protection

Airflow Choice

- Units are shipped in downflow (vertical) return air flow configuration

NOTE - Units can be field converted to horizontal air flow with optional Horizontal Return Air Panel Kit and Horizontal Roof Curb.

Power Entry

- Electrical lines can be brought through the unit base or through horizontal access knock-outs

Exterior Panels

- Constructed of heavy-gauge, galvanized steel
- Two-layer enamel paint finish

Insulation

- Fully insulated with non-hygroscopic fiberglass insulation (conditioned areas)
- Unit base is fully insulated
- Base insulation serves as an air seal to the roof curb, eliminating the need to add a seal during installation

Access Panels

- Filter section
- Blower section
- Heating section
- Compressor/controls section

Options/Accessories

Factory Installed

Corrosion Protection

- Completely flexible immersed coating
- Electrodeposited dry film process
- AST ElectroFin E-Coat
- Meets Mil Spec MIL-P-53084, ASTM B117 Standard Method Salt Spray Testing
- Indoor Corrosion Protection:
 - Coated coil
 - Painted blower housing
 - Painted base
- Outdoor Corrosion Protection:
 - Coated coil
 - Painted outdoor base

Hinged Access Panels

- Filter section
- Blower section
- Heating section
- Compressor/controls section
- Panel seals and quarter-turn latching handles provide a tight air and water seal

Field Installed

Combination Coil/Hail Guards

- Heavy gauge steel frame
- Painted to match cabinet
- Expanded metal mesh protects outdoor coil

Horizontal Return Air Panel Kit

- Required for horizontal applications with Horizontal Roof Curb
- Contains panel with return air opening for field replacement of existing unit panel and panel to cover bottom return air opening in unit
- See dimension drawings

BLOWER

- A wide selection of supply air blower options are available to meet a variety of airflow requirements

8 Motor

- Overload protected
- Ball bearings
- Belt drive motors are offered on all models and are available in several different sizes to maximize air performance

Supply Air Blower

- Forward curved blades
- Double inlet
- Blower wheel statically and dynamically balanced
- Ball bearings
- Adjustable pulley (allows speed change)
- Blower assembly slides out of unit for servicing

FEATURES AND BENEFITS

BLOWER (continued)

Required Selections

Select MSAV® (Multi-Stage Air Volume) Supply Air Blower Option

- Order blower motor horsepower and drive kit number required when base unit is ordered
- See Drive Kit Specifications Table

MSAV Operation

- Units ordered with the MSAV option utilize a Variable Frequency Drive (VFD) to stage the supply air blower airflow
- VFD alters the frequency and voltage of the power supply to the blower to control blower speed
- The supply air blower has two speeds:
 1. Low speed for part-load cooling operation. Note - Low speed is 66% of high speed.
 2. High speed for full load cooling and all heat modes.
- Full speed blower operation is set by adjusting the motor pulley to deliver the desired air volume
- The ventilation speed is selectable between high and low speed

NOTE - Part load airflow in cooling mode on **MSAV** units should not be set below 220 cfm/nominal full load ton to reduce the risk of evaporator coil freeze-up.

- VFD has an operational range of -40 to 125° F outdoor air ambient temperature

NOTE - Lower operating costs are obtained when the blower is operated on lower speeds.

MSAV Sequence of Operation

- Ventilation speed is determined by the VENT SPEED switch setting on VFD control board (LO or HI)
- Blower operates in low speed for mechanical cooling (Y1)
- Blower operates in high speed for any other mode (free cooling, mechanical cooling Y1+Y2, and heating)
- Economizer damper minimum position is fully closed in unoccupied mode
- In occupied mode, the economizer damper minimum position is determined by the setting of the two potentiometers on VFD control board
 - LO SPD MIN POS potentiometer sets the minimum position when blower is operating at low speed
 - HI SPD MIN POS potentiometer sets the minimum position when blower is operating at high speed

NOTE - Units equipped a Variable Frequency Drive (VFD) are designed to operate on balanced, three-phase power. Operating units on unbalanced three-phase power will reduce the reliability of all electrical components in the unit. Unbalanced power is a result of the power delivery system supplied by the local utility company. Factory-installed inverters are sized to drive blower motors with an equivalent current rating using balanced three-

phase power. If unbalanced three-phase power is supplied; the installer must replace the existing factory-installed inverter with an inverter that has a higher current rating to allow for the imbalance. Refer to the installation instructions for additional information and replacement information.

Options/Accessories

Field Installed

VFD Manual Bypass Kit

- VFD Manual Bypass Control is available as a kit for units equipped with the MSAV option
- The VFD Manual Bypass Control is a manual bypass and is enabled by re-configuring the wiring on the unit

CONTROLS

9 Unit Control

- All control voltage is provided via a 24V (secondary) transformer with built-in circuit breaker protection
- **Heat/Cool Staging** - Capable of up to 2 heat / 2 cool staging with a third party DDC control system or thermostat
- **Low Voltage Terminal Block** - Provides screw terminal connections for thermostat or controller wiring
- **Night Setback Mode** - Saves energy by closing outdoor air dampers and operating supply fan on thermostat demand only

Defrost Control

- Provides a defrost cycle, if needed, every 30 or 60 or 90 minutes (adjustable) of compressor "on" time at outdoor coil temperature below 35°F
- Pressure switch mounted on outdoor coil vapor line terminates defrost cycle

Options/Accessories

Field Installed

L Connection® Network

- Complete building automation control system for single or multi-zone applications. Options include local interface, software for local or remote communication, and hardware for networking other control functions.
- See L Connection Network Product Specifications Bulletin for details.

Smoke Detector

- Photoelectric type
- Installed in supply air section, return air section or both sections
- Available with power board and single sensor (supply or return) or power board and two sensors (supply and return)
- Power board located in unit control compartment.

Thermostats

- Control system and thermostat options, see page 9

FEATURES AND BENEFITS

ELECTRICAL

- All units include terminal block and fuse block in power entry junction box for single power entry application

Marked & Color-Coded Wiring

- All electrical wiring is color-coded and marked to identify which components it is connecting

Electrical Plugs

- Positive connection electrical plugs are used to connect common accessories or maintenance parts for easy removal or installation

Phase Monitor

- Phase monitor detects the phasing of incoming power
- If incoming power is out of phase or if any of the three phases are lost, an indicator LED on the phase monitor will turn red and the unit will not start
- In normal operation with correct incoming power phasing, the LED will be green

NOTE - Phase Monitor is factory installed in the control compartment on all units equipped with the MSAV® Supply Air Blower option.

Required Selections

Voltage Choice

- Specify when ordering base unit

Options/Accessories

Factory or Field Installed

10 Disconnect Switch

- Accessible from outside of unit
- Spring loaded weatherproof cover furnished

GFI Service Outlets (2)

- 115V ground fault circuit interrupter (GFCI) type
- Non-powered
- Field-wired

Field Installed

11 Electric Heat

- Helix wound nichrome elements
- Individual element limit controls
- Wiring harness
- Unit fuse block
- See Options / Accessories tables for ordering information

GFI Weatherproof Cover

- Single-gang cover
- Heavy-duty UV-resistant polycarbonate case construction
- Hinged base cover with gasket

INDOOR AIR QUALITY

12 Air Filters

- Disposable 2-inch filters furnished as standard

Options/Accessories

Field Installed

Healthy Climate® High Efficiency Air Filter

- Disposable MERV 8 or MERV 13 (Minimum Efficiency Reporting Value based on ASHRAE 52.2) efficiency 2-inch pleated filters

Replacement Filter Media Kit With Frame

- Replaces existing pleated filter media
- Washable metal mesh screen and metal frame with clip for holding replaceable non-pleated filter

Healthy Climate® UVC Germicidal Lamps

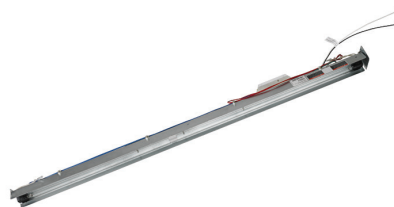

- Germicidal lamps emit ultra-violet (UV-C) energy, which has been proven to be effective in reducing microbes such as viruses, bacteria, yeasts, and molds
- This process either destroys the organism or controls its ability to reproduce
- UV-C energy greatly reduces the growth and proliferation of mold and other bioaerosols (bacteria and viruses) on illuminated surfaces (particularly coil and drain pan)
- Field installed in the blower/evaporator coil section
- Magnetic safety interlock terminates power when access panels are removed
- All necessary hardware for installation is included
- Lamps operate on 110/230V-1ph power supply

NOTE - Step-down transformer may be ordered separately for 460V and 575V units.

- Approved by ETL

Indoor Air Quality (CO₂) Sensors

- Monitors CO₂ levels
- Reports to the Unit Controller which adjusts economizer dampers as needed

OPTIONS / ACCESSORIES

ECONOMIZER

Factory or Field Installed

- 13** Economizer
(Standard and High Performance Common Features)
- Outdoor Air Hood with mist elimination filter is furnished
 - Mixed Air Sensor is furnished for field installation in the rooftop unit

NOTE - Sensor is factory installed when Economizers are factory installed.

Standard Economizer Features (Not for Title 24)

- Gear-driven action
- Return air and outdoor air dampers
- Plug-in connections to unit
- Nylon bearings
- Neoprene seals
- 24-volt, fully-modulating spring return motor

Standard Economizer Control Module

- The Standard Economizer Control Module can be adjusted to operate based on outdoor air temperatures



Economizer Controls:

- **Damper Minimum Position** - Can be set lower than traditional minimum air requirements resulting in cost savings
- **IAQ Sensor** - Signals dampers to modulate and maintain 55°F when CO₂ is higher than the CO₂ setpoint
- **Demand Control Ventilation (DCV) LED** - A steady green Demand Control Ventilation LED indicates the IAQ reading is higher than setpoint and requires more fresh air
- **Free Cool LED** - A steady green LED indicates outdoor air is suitable for free cooling
 - Free Cooling runs when outdoor air temperature is lower than the set temperature on the economizer control

NOTE: The Free Cooling default setting for outdoor air temperature sensor is 55°F.

High Performance Economizer Features

- Approved for California Title 24 building standards
- Low leakage dampers are Air Movement and Control Association International (AMCA) Class 1A Certified - Maximum 3 cfm per sq. ft. leakage at 1 in. w.g.
- ASHRAE 90.1 compliant
- Gear-driven action
- High torque 24-volt fully-modulating spring return damper motor
- Return air and outdoor air dampers
- Plug-in connections to unit
- Stainless steel bearings
- Enhanced thermoplastic vulcanizate (TPV) seals
- Flexible stainless steel jamb seals

NOTE - High Performance Economizers are not approved for use with enthalpy controls in Title 24 applications.

NOTE - The free cooling setpoint for Title 24 applications must be set based on the Climate Zone where the system is installed. See Section 140.4 "Prescriptive Requirements for Space Conditioning Systems" of the California Energy Commission's 2013 Building Energy Efficiency Standards. Refer to Installation Instructions for complete setup information and menu parameters available.

High Performance Economizer Control Module

- Module provides inputs and outputs to control economizer based on parameter settings
- Module automatically detects sensors by polling to determine which sensors are installed in system
- Module displays any alarm messages (fault detection and diagnostics) as an aid in troubleshooting
- Non-volatile memory retains parameter settings in case of power failure
- Keypad with four navigation buttons and LCD screen is furnished for setting economizer parameters
 - Menu Up/Exit (↑) button returns to the main menu
 - Arrow Up (▲) button moves to the previous or next parameter within the selected menu
 - Arrow Down (▼) button moves to the next parameter within the selected menu
 - Select (enter) (↵) button confirms parameter selection



Main Menu Structure:

- **Status** (economizer and system operation status)
- **Setpoints** (settings for various setpoint parameters)
- **System Setup** (settings/information about the system)
- **Advanced Setup** (freeze protection, CO₂ settings, stage 3 delay and additional calibration settings)
- **Checkout** (damper positions)
- **Alarms** (output signal that can be configured for remote alarm monitoring)

Factory or Field Installed

Single Enthalpy Temperature Control (Not for Title 24)

- Outdoor air enthalpy sensor enables Economizer if the outdoor enthalpy is less than the setpoint of the control

Field Installed

Differential Enthalpy Control (Not for Title 24)

- Order two Single Enthalpy Controls
- One is field installed in the return air section, the other in the outdoor air section
- Allows the economizer control board to select between outdoor air or return air, whichever has lower enthalpy

OPTIONS / ACCESSORIES

EXHAUST

Factory or Field Installed

14 Downflow Barometric Relief Dampers With Exhaust Hood

- Allow relief of excess air
- Aluminum blade dampers prevent blow back and outdoor air infiltration during off cycle
- Exhaust hood with bird screen furnished

Field Installed

Horizontal Barometric Relief Dampers With Exhaust Hood

- For use when unit is configured for horizontal applications requiring an economizer
- Allows relief of excess air
- Aluminum blade dampers prevent blow back and outdoor air infiltration during off cycle
- Field installed in return air duct
- Exhaust hood with bird screen furnished

15 Power Exhaust Fan

- Installs internal to unit for downflow applications only with economizer option
- Provides exhaust air pressure relief. Interlocked to run when supply air blower is operating
- Fans runs when outdoor air dampers are 50% open (adjustable)
- Motor is overload protected
- Dual 20 in. diameter fans
- 5 blades
- Two 1/3 hp motors

NOTE - Requires Economizer with Outdoor Air Hood and Downflow Barometric Relief Dampers.

OUTDOOR AIR

Factory or Field Installed

Outdoor Air Damper - Downflow or Horizontal With Air Hood

- Linked mechanical dampers
- 0 to 25% (fixed) outdoor air adjustable
- Installs in unit
- Includes outdoor air hood
- Automatic model features fully modulating spring return damper motor with plug-in connection
- Manual model features parallel blade with gear-driven dampers and adjustable fixed position

NOTE - Outdoor Air Hood is included when damper is factory installed and is furnished with damper when ordered for field installation.

ROOF CURBS

- Nailer strip furnished (downflow only)
- Mates to unit
- US National Roofing Contractors Approved
- Shipped knocked down

Hybrid Roof Curbs, Downflow

- Interlocking tabs fasten corners together
- No tools required
- Can also be fastened together with furnished hardware
- Available in 8, 14, 18, and 24 inch heights

Adjustable Pitch Curb, Downflow

- Fully adjustable pitch curbs (3/4 in. per foot in any direction) provide a level platform for rooftop units allowing flexible installations on roofs with uneven or sloped angles
- Uses interlocking tabs to fasten corners together. No tools required
- Hardware is furnished to connect upper curb with lower curb
- Available in 14 inch height

Horizontal

- Converts unit from downflow to horizontal (side) air flow
- Return air is on unit
- Supply air is on curb
- See dimension drawings

NOTE - Requires Horizontal Return Air Panel Kit. Available in 26, 30, 37 and 41 inch heights. Optional Insulation Kit is available to help prevent sweating.

Adaptor Curbs (not shown)

- Curbs are regionally sourced
- Dimensions vary based upon the source

NOTE - Contact your local sales representative for a detailed cut sheet with applicable dimensions.

CEILING DIFFUSERS

Field Installed

Ceiling Diffusers (Flush or Step-Down)

- White powder coat finish on diffuser face and grilles
- Insulated UL listed duct liner
- Diffuser box has collars for duct connection
- Step-down diffusers have double deflection blades
- Flush diffusers have fixed blades
- Provisions for suspending
- Internally sealed to prevent recirculation
- Removable return air grille
- Adapts to T-bar ceiling grids or plaster ceilings

Transitions (Supply and Return)

- Used with diffusers
- Installs in roof curb
- Galvanized steel construction
- Flanges furnished for duct connection to diffusers
- Fully insulated

OPTIONAL CONVENTIONAL TEMPERATURE CONTROL SYSTEMS

ComfortSense® 7500 Commercial 7-Day Programmable Thermostat



- Four-Stage Heating / Two-Stage Cooling
- Universal Multi-Stage
- Intuitive Touchscreen Interface
- Automatic Changeover between Heating and Cooling
- Full Seven-Day Programming
- Four Time Periods Per Day
- Temperature and Humidity Control
- One-Touch Away Mode
- Holiday Scheduling
- Smooth Setback Recovery (SSR)
- Performance Reports
- Notifications/Reminders
- Dehumidification/Humiditrol® Control for Split Systems and Rooftop Units
- Economizer Relay Control
- Backlit Display
- Wallplate Furnished
- FDD, ASHRAE and IECC Compliant

ComfortSense® 3000 Commercial 5-2 Day Programmable Thermostat

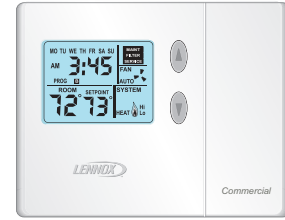

- Two-Stage Heating / Two-Stage Cooling
- Conventional Systems
- Intuitive Interface
- 5-2 Day Programming
- Program Hold
- Remote Indoor Temperature Sensing
- Smooth Setback Recovery (SSR)
- Economizer Relay Control
- Maintenance/Filter/Service Reminders
- Backlit Display
- Wallplate Furnished
- Simple Up and Down Temperature Control

Bacnet Compatible Thermostat With Reheat Function



- 7-Day Programmable
- For units with or without Humiditrol®
- BTL listed MS/TP ensures compatibility with any BACnet system
- Built-in control programs for conventional and heat pump applications
- Conventional systems up to 3-stage heat and 3-stage cool
- Heat pumps with 1 or 2 compressors and up to 2-stage auxiliary heat
- On-board temperature and humidity sensor
- Multiple configurable inputs and outputs enable advanced control strategies
- Set-up Wizard enables rapid system configuration
- No special tools required for installation or commissioning
- Seven-day (2, 4 or 6 event) occupancy scheduling per day
- Backlit 5-inch LCD touchscreen

Description	Catalog No.
ComfortSense® 7500 Commercial 7-Day Programmable Thermostat	
CS7500 7-Day Thermostat	17G74
Sensors/	¹ Remote non-adjustable wall-mount 20k 47W36
Accessories	¹ Remote non-adjustable wall-mount 10k 47W37
	Remote non-adjustable discharge air (duct mount) 19L22
	Outdoor temperature sensor X2658
ComfortSense® 3000 5-2 Day Programmable	
CS3000 5-2 Day Thermostat	11Y05
Sensor/	Remote non-adjustable wall mount 10k averaging 47W37
Accessories	Thermostat wall mounting plate X2659
BACnet	² 7-Day BACnet Thermostat Y8241
Controls	³ BACnet Module (factory or field) 16X72
⁴ BACnet	With Display 97W23
Room Sensors	Without Display 97W24
Universal Thermostat Guard with Lock (clear)	
	Inside Dimensions (H x W) 5 7/8 x 8 3/8 in. 39P21

¹ Remote wall-mount sensors can be applied in any of the following combinations:
 One Sensor - (1) 47W36, Two Sensors - (2) 47W37, Three Sensors - (2) 47W36 and (1) 47W37
 Four Sensors - (4) 47W36, Five Sensors - (3) 47W36 and (2) 47W37

² BACnet Thermostat (Y8241) will control units with and without the Humiditrol® option. If there is a mix of units equipped with and without Humiditrol on the same site, this thermostat can be used for all units if suitable.

³ Not compatible with units equipped with Humiditrol® option.

⁴ Only compatible with BACnet Module (16X70).

OPTIONS / ACCESSORIES

Item Description	Catalog Number	180	240	
COOLING SYSTEM				
Condensate Drain Trap	PVC	22H54	X	X
	Copper	76W27	X	X
Corrosion Protection	Factory	O	O	
Drain Pan Overflow Switch	10C24	X	X	
Efficiency	Standard	O	O	
Low Ambient Kit	55W73	X	X	
Refrigerant Type	R-410A	O	O	
BLOWER - SUPPLY AIR				
Blower Options	MSAV (Multi-Stage Air Volume)	Factory	O	O
Motors - MSAV® (Multi-Stage Air Volume)	Belt Drive - 3 hp	Factory	O	
	Belt Drive - 5 hp	Factory	O	O
	Belt Drive - 7.5 hp	Factory	O	O
	Belt Drive - 10 hp	Factory		O
VFD Manual Bypass Kit (for MSAV® equipped units)	3 hp, 5 hp (208/230V)	90W52	X	X
	3 hp, 5 hp, 7.5 hp, 10 hp (460V and 575V)	90W51	X	X
Drive Kits See Blower Data Tables for usage and selection	Kit #1 535-725 rpm	Factory	O	
	Kit #2 710-965 rpm	Factory	O	
	Kit #3 685-856 rpm	Factory	O	O
	Kit #4 850-1045 rpm	Factory	O	O
	Kit #5 945-1185 rpm	Factory	O	O
	Kit #6 850-1045 rpm	Factory	O	O
	Kit #7 945-1185 rpm	Factory	O	O
	Kit #8 1045-1285 rpm	Factory	O	O
	Kit #10 1045-1285 rpm	Factory		O
	Kit #11 1135-1365 rpm	Factory		O
	CABINET			
Combination Coil/Hail Guards	13T26	X	X	
Hinged Access Panels	Factory	O	O	
CONTROLS				
NOTE - Also see Conventional Thermostat Control Systems on page 9 for Additional Options.				
Smoke Detector - Supply or Return (Power board and one sensor)	83W40	X	X	
Smoke Detector - Supply and Return (Power board and two sensors)	83W41	X	X	
Commercial Controls	L Connection® Building Automation System	- - -	X	X

NOTE - Catalog numbers shown are for ordering field installed accessories.

OX - Configure To Order (Factory Installed) or Field Installed

O = Configure To Order (Factory Installed)

X = Field Installed

OPTIONS / ACCESSORIES

Item Description	Catalog Number	180	240	
INDOOR AIR QUALITY				
Air Filters				
Healthy Climate® High Efficiency Air Filters 24 x 24 x 2 (Order 6 per unit)	MERV 8	54W67	X	X
	MERV 13	52W40	X	X
Replacement Media Filter With Metal Mesh Frame (includes non-pleated filter media)		44N61	X	X
Indoor Air Quality (CO₂) Sensors				
Sensor - Wall-mount, off-white plastic cover with LCD display		77N39	X	X
Sensor - Wall-mount, off-white plastic cover, no display		87N53	X	X
Sensor - Black plastic case with LCD display, rated for plenum mounting		87N52	X	X
Sensor - Wall-mount, black plastic case, no display, rated for plenum mounting		87N54	X	X
CO ₂ Sensor Duct Mounting Kit - for downflow applications		85L43	X	X
Aspiration Box - for duct mounting non-plenum rated CO ₂ sensors (87N53 or 77N39)		90N43	X	X
UVC Germicidal Light Kit				
¹ Healthy Climate® UVC Light Kit (110/230v-1ph)		21A94	X	X
Step-Down Transformers	460V primary, 230V secondary	10H20	X	X
	575V primary, 230V secondary	10H21	X	X
ELECTRICAL				
Voltage 60 hz	208/230V - 3 phase	Factory	O	O
	460V - 3 phase	Factory	O	O
	575V - 3 phase	Factory	O	O
Disconnect Switch (see Electric Heat Tables for usage)	80 amp	54W85	OX	OX
	150 amp	54W86	OX	OX
	250 amp	54W87	OX	OX
GFI Service Outlets	15 amp non-powered, field-wired (208/230V, 460V only)	74M70	OX	OX
	20 amp non-powered, field-wired (575V only)	67E01	X	X
Weatherproof Cover for GFI		10C89	X	X
ELECTRIC HEAT				
15 kW	208/230V-3ph	53W84	X	X
	460V-3ph	53W86	X	X
	575V-3ph	53W87	X	X
30 kW	208/230V-3ph	53W92	X	X
	460V-3ph	53W94	X	X
	575V-3ph	53W95	X	X
45 kW	208/230V-3ph	54W00	X	X
	460V-3ph	54W02	X	X
	575V-3ph	54W03	X	X
60 kW	208/230V-3ph	54W08	X	X
	460V-3ph	54W10	X	X
	575V-3ph	54W11	X	X
90 kW	208/230V-3ph	54W12		X
	460V-3ph	54W14		X
	575V-3ph	54W15		X

¹ Lamps operate on 110-230V single-phase power supply. Step-down transformer may be ordered separately for 460V and 575V units. Alternately, 110V power supply may be used to directly power the UVC ballast(s).

NOTE - Catalog numbers shown are for ordering field installed accessories.

OX - Configure To Order (Factory Installed) or Field Installed

O = Configure To Order (Factory Installed)

X = Field Installed

OPTIONS / ACCESSORIES

Item Description	Catalog Number	180	240	
ECONOMIZER				
Standard Economizer With Outdoor Air Hood (Not for Title 24)				
Standard Economizer Downflow or Horizontal Applications - Includes Outdoor Air Hood, order Downflow or Horizontal Barometric Relief Dampers separately	54W77	OX	OX	
Standard Economizer Controls (Not for Title 24)				
Single Enthalpy Control	21Z09	OX	OX	
Differential Enthalpy Control (order 2)	21Z09	X	X	
High Performance Economizer With Outdoor Air Hood (Approved for California Title 24 Building Standards / AMCA Class 1A Certified)				
High Performance Economizer Downflow or Horizontal Applications - Includes Outdoor Air Hood, order Downflow or Horizontal Barometric Relief Dampers separately	16X77	OX	OX	
High Performance Economizer Controls (Not for Title 24)				
Single Enthalpy Control	10Z75	OX	OX	
Differential Enthalpy Control (order 2)	10Z75	X	X	
Barometric Relief Dampers With Exhaust Hood				
Downflow Barometric Relief Dampers	54W78	OX	OX	
Horizontal Barometric Relief Dampers	16K99	X	X	
OUTDOOR AIR				
Outdoor Air Dampers With Outdoor Air Hood				
Motorized	13U04	OX	OX	
Manual	13U05	OX	OX	
¹ POWER EXHAUST (DOWNFLOW APPLICATIONS ONLY)				
Standard Static	208/230V	75W90	X	X
	460V	75W91	X	X
	575V	75W92	X	X
ROOF CURBS				
Hybrid Roof Curbs, Downflow				
8 in. height	11F58	X	X	
14 in. height	11F59	X	X	
18 in. height	11F60	X	X	
24 in. height	11F61	X	X	
Adjustable Pitch Curb				
14 in. height	43W26	X	X	
Standard Roof Curbs, Horizontal - Requires Horizontal Return Air Panel Kit				
26 in. height - slab applications	11T89	X	X	
37 in. height - rooftop applications	11T96	X	X	
Insulation Kit For Standard Horizontal Curbs				
For 26 in. Curb	73K32	X	X	
For 37 in. Curb	73K34	X	X	
Horizontal Return Air Panel Kit				
Required for Horizontal Applications with Roof Curb	87M00	X	X	
CEILING DIFFUSERS				
Step-Down - Order one	RTD11-185S	13K63	X	
	RTD11-275S	13K64		X
Flush - Order one	FD11-185S	13K58	X	
	FD11-275S	13K59		X
Transitions (Supply and Return) - Order one	C1DIFF33C-1	12X68	X	
	C1DIFF34C-1	12X70		X

¹ Field installed Power Exhaust requires Economizer with Outdoor Air Hood and Downflow Barometric Relief Dampers with Exhaust Hood. Must be ordered separately.

NOTE - Catalog and model numbers shown are for ordering field installed accessories.

OX - Configure To Order (Factory Installed) or Field Installed

O = Configure To Order (Factory Installed)

X = Field Installed

SPECIFICATIONS

General Data		Nominal Tonnage	15 Ton	20 Ton
		Model Number	KHA180S4M	KHA240S4M
		Efficiency Type	Standard	Standard
		Blower Type	MSAV (Multi-Stage Air Volume)	MSAV (Multi-Stage Air Volume)
Cooling Performance	Gross Cooling Capacity - Btuh		179,000	226,000
	¹ Net Cooling Capacity - Btuh		174,000	214,000
	AHRI Rated Air Flow - cfm		6000	7500
	Total Unit Power - kW		16.4	20.5
	¹ EER (Btuh/Watt)		10.6	10.6
	² IEER (Btuh/Watt)		13.2	13.0
	Refrigerant Type		R-410A	R-410A
Refrigerant Charge	Circuit 1	21 lbs. 0 oz.	26 lbs. 0 oz.	
Furnished	Circuit 2	21 lbs. 0 oz.	26 lbs. 0 oz.	
Heating Performance	¹ Total High Heat Capacity - Btuh		178,000	220,000
	Total Unit Power - kW		16.1	19.9
	¹ C.O.P.		3.2	3.2
	¹ Total Low Heat Capacity - Btuh		100,000	124,000
	Total Unit Power (kW)		14.9	18.3
	¹ C.O.P.		2.05	2.05
Electric Heat Available - See page 11			15-30-45-60 kW	15-30-45-60-90 kW
Compressor Type (number)			Scroll (2)	Scroll (2)
Outdoor Coils	Net face area (total) - sq. ft.		57.0	57.0
	Tube diameter - in.		3/8	3/8
	Fins per inch		20	20
Outdoor Coil Fans	Motor - (No.) horsepower		(4) 1/3	(4) 1/3
	Motor rpm		1075	1075
	Total Motor watts		1500	1500
	Diameter - (No.) in.		(4) 24	(4) 24
	Number of blades		3	3
	Total Air volume - cfm		15,450	15,450
Indoor Coils	Net face area (total) - sq. ft.		21.4	21.4
	Tube diameter - in.		3/8	3/8
	Number of rows		3	4
	Fins per inch		14	14
	Drain connection - No. and size		(1) 1 in. FPT	(1) 1in. FPT
	Expansion device type		Balance port TXV, removable head	
³ Indoor Blower and Drive Selection	Nominal motor output		3 hp, 5 hp, 7.5 hp	5 hp, 7.5 hp, 10 hp
	Maximum usable motor output (US Only)		3.45 hp, 5.75 hp, 8.63 hp	5.75 hp, 8.63 hp, 11.5 hp
	Motor - Drive kit number		3 hp Kit 1 535-725 rpm Kit 2 710-965 rpm 5 hp Kit 3 685-856 rpm Kit 4 850-1045 rpm Kit 5 945-1185 rpm 7.5 hp Kit 6 850-1045 rpm Kit 7 945-1185 rpm Kit 8 1045-1285 rpm	5 hp Kit 3 685-856 rpm Kit 4 850-1045 rpm Kit 5 945-1185 rpm 7.5 hp Kit 6 850-1045 rpm Kit 7 945-1185 rpm Kit 8 1045-1285 rpm 10 hp Kit 7 945-1185 rpm Kit 10 1045-1285 rpm Kit 11 1135-1365 rpm
	Blower wheel nominal diameter x width - in.		(2) 15 x 15	(2) 15 x 15
Filters	Type of filter		Fiberglass, disposable	
	Number and size - in.		(6) 24 x 24 x 2	
Electrical characteristics			208/230V, 460V or 575V - 60 hertz - 3 phase	

NOTE - Gross cooling capacity includes evaporator blower motor heat deduction. Net cooling capacity does not include evaporator blower motor heat deduction.

¹ AHRI Certified to AHRI Standard 340/360:

Cooling Ratings - 95°F outdoor air temperature and 80°F db/67°F wb entering indoor coil air.

High Temperature Heating Ratings - 47°F db/43°F wb outdoor air temperature and 70°F entering indoor coil air.

Low Temperature Heating Ratings - 17°F db/15°F wb outdoor air temperature and 70°F entering indoor coil air.

² Integrated Energy Efficiency Ratio tested according to AHRI Standard 340/360.

³ Using total air volume and system static pressure requirements determine from blower performance tables rpm and motor output required. Maximum usable output of motors furnished are shown. In Canada, nominal motor output is also maximum usable motor output. If motors of comparable output are used, be sure to keep within the service factor limitations outlined on the motor nameplate.

NOTE - All models are limited to a motor service factor of 1.0.

RATINGS

NOTE – For Temperatures and Capacities not shown in tables, see bulletin – Cooling Unit Rating Table Correction Factor Data in Miscellaneous Engineering Data section.

15 TON COOLING STANDARD EFFICIENCY KHA180S4 (1ST STAGE) - MSAV (Multi-Stage Air Volume) SUPPLY AIR BLOWER

Entering Wet Bulb Temperature	Total Air Volume	Outdoor Air Temperature Entering Outdoor Coil																			
		65°F					75°F					85°F					95°F				
		Total Cool Cap.	Comp. Motor Input	Sensible To Total Ratio (S/T) Dry Bulb			Total Cool Cap.	Comp. Motor Input	Sensible To Total Ratio (S/T) Dry Bulb			Total Cool Cap.	Comp. Motor Input	Sensible To Total Ratio (S/T) Dry Bulb			Total Cool Cap.	Comp. Motor Input	Sensible To Total Ratio (S/T) Dry Bulb		
				75°F	80°F	85°F			75°F	80°F	85°F			75°F	80°F	85°F			75°F	80°F	85°F
cfm	kBtuh	kW	75°F	80°F	85°F	kBtuh	kW	75°F	80°F	85°F	kBtuh	kW	75°F	80°F	85°F	kBtuh	kW	75°F	80°F	85°F	
63°F	3500	87	4.68	0.67	0.76	0.86	83.2	5.22	0.67	0.77	0.87	79.2	5.83	0.67	0.78	0.88	74.8	6.52	0.68	0.79	0.9
	4000	90.8	4.74	0.68	0.79	0.89	86.8	5.28	0.69	0.8	0.9	82.4	5.88	0.69	0.81	0.92	77.8	6.57	0.7	0.82	0.94
	4500	93.6	4.79	0.7	0.81	0.92	89.5	5.32	0.7	0.82	0.93	85.1	5.92	0.71	0.83	0.95	80.3	6.61	0.72	0.85	0.97
67°F	3500	91.9	4.76	0.54	0.64	0.73	88.1	5.29	0.54	0.64	0.74	83.8	5.9	0.54	0.65	0.75	79.5	6.59	0.54	0.65	0.76
	4000	95.8	4.81	0.55	0.66	0.76	91.8	5.35	0.55	0.66	0.76	87.4	5.96	0.55	0.67	0.77	82.5	6.64	0.56	0.68	0.79
	4500	99	4.86	0.56	0.68	0.78	94.7	5.4	0.56	0.68	0.79	90	6	0.57	0.69	0.8	85	6.67	0.57	0.7	0.82
71°F	3500	96.9	4.83	0.43	0.53	0.62	92.9	5.37	0.43	0.52	0.62	88.7	5.97	0.42	0.52	0.62	84	6.66	0.42	0.53	0.63
	4000	100.9	4.89	0.43	0.54	0.63	96.6	5.42	0.43	0.54	0.64	92.2	6.03	0.43	0.54	0.64	87.1	6.72	0.43	0.54	0.65
	4500	104.1	4.94	0.44	0.55	0.65	99.9	5.48	0.44	0.55	0.66	94.9	6.08	0.43	0.55	0.67	89.8	6.76	0.43	0.55	0.68

15 TON COOLING STANDARD EFFICIENCY KHA180S4 (2ND STAGE) - MSAV (Multi-Stage Air Volume) SUPPLY AIR BLOWER

Entering Wet Bulb Temperature	Total Air Volume	Outdoor Air Temperature Entering Outdoor Coil																			
		85°F					95°F					105°F					115°F				
		Total Cool Cap.	Comp. Motor Input	Sensible To Total Ratio (S/T) Dry Bulb			Total Cool Cap.	Comp. Motor Input	Sensible To Total Ratio (S/T) Dry Bulb			Total Cool Cap.	Comp. Motor Input	Sensible To Total Ratio (S/T) Dry Bulb			Total Cool Cap.	Comp. Motor Input	Sensible To Total Ratio (S/T) Dry Bulb		
				75°F	80°F	85°F			75°F	80°F	85°F			75°F	80°F	85°F			75°F	80°F	85°F
cfm	kBtuh	kW	75°F	80°F	85°F	kBtuh	kW	75°F	80°F	85°F	kBtuh	kW	75°F	80°F	85°F	kBtuh	kW	75°F	80°F	85°F	
63°F	4800	170.3	11.79	0.71	0.84	0.96	160.7	13.14	0.72	0.86	0.98	150.1	14.67	0.74	0.88	0.99	138.9	16.45	0.76	0.91	1
	6000	179.1	11.92	0.76	0.91	1	168.7	13.27	0.78	0.93	1	157.8	14.81	0.8	0.96	1	145.8	16.57	0.82	0.98	1
	7200	185.7	12.04	0.81	0.96	1	175	13.37	0.83	0.98	1	164.2	14.91	0.85	0.99	1	152.7	16.7	0.88	1	1
67°F	4800	180.3	11.94	0.57	0.69	0.81	170.2	13.29	0.57	0.7	0.83	159.8	14.84	0.57	0.72	0.85	147.9	16.62	0.58	0.73	0.88
	6000	189.7	12.09	0.6	0.74	0.88	178.8	13.44	0.6	0.76	0.9	167.4	14.97	0.61	0.77	0.93	154.8	16.74	0.62	0.8	0.96
	7200	196.4	12.21	0.63	0.79	0.94	185.1	13.55	0.63	0.81	0.96	173.1	15.08	0.65	0.83	0.98	159.9	16.84	0.66	0.86	0.99
71°F	4800	190.1	12.1	0.43	0.55	0.67	179.8	13.46	0.43	0.56	0.68	168.7	14.99	0.43	0.56	0.69	156.3	16.77	0.42	0.57	0.71
	6000	200	12.27	0.44	0.58	0.72	188.6	13.61	0.44	0.59	0.73	176.9	15.14	0.44	0.6	0.75	163.9	16.91	0.44	0.61	0.78
	7200	206.8	12.38	0.46	0.62	0.77	195.3	13.73	0.46	0.63	0.79	183	15.26	0.46	0.64	0.81	169.2	17.02	0.46	0.65	0.84

15 TON HEATING STANDARD EFFICIENCY KHA180S4 - MSAV (Multi-Stage Air Volume) SUPPLY AIR BLOWER

Indoor Coil Air Volume 70°F Dry Bulb cfm	Air Temperature Entering Outdoor Coil									
	65°F		45°F		25°F		5°F		-15°F	
	Total Heating Capacity	Comp. Motor Input	Total Heating Capacity	Comp. Motor Input	Total Heating Capacity	Comp. Motor Input	Total Heating Capacity	Comp. Motor Input	Total Heating Capacity	Comp. Motor Input
4800	207.5	13.75	170.7	12.84	111.4	11.83	81.1	10.32	39.6	7695
6000	210.9	13.03	174.1	12.12	113.8	11.11	83.0	9.60	41.6	6980
7200	213.3	12.56	176.5	11.65	116.3	10.66	85.4	9.18	44.0	6560

RATINGS

NOTE – For Temperatures and Capacities not shown in tables, see bulletin – Cooling Unit Rating Table Correction Factor Data in Miscellaneous Engineering Data section.

20 TON COOLING STANDARD EFFICIENCY KHA240S4 (1ST STAGE) - MSAV (Multi-Stage Air Volume) SUPPLY AIR BLOWER

Entering Wet Bulb Temperature	Total Air Volume	Outdoor Air Temperature Entering Outdoor Coil																			
		65°F					75°F					85°F					95°F				
		Total Cool Cap.	Comp. Motor Input	Sensible To Total Ratio (S/T) Dry Bulb			Total Cool Cap.	Comp. Motor Input	Sensible To Total Ratio (S/T) Dry Bulb			Total Cool Cap.	Comp. Motor Input	Sensible To Total Ratio (S/T) Dry Bulb			Total Cool Cap.	Comp. Motor Input	Sensible To Total Ratio (S/T) Dry Bulb		
				75°F	80°F	85°F			75°F	80°F	85°F			75°F	80°F	85°F			75°F	80°F	85°F
cfm	kBtuh	kW	75°F	80°F	85°F	kBtuh	kW	75°F	80°F	85°F	kBtuh	kW	75°F	80°F	85°F	kBtuh	kW	75°F	80°F	85°F	
63°F	4500	110.9	5.6	0.66	0.75	0.84	105.9	6.3	0.66	0.76	0.85	100.8	7.09	0.66	0.77	0.87	95.3	7.98	0.67	0.78	0.88
	5500	118.3	5.69	0.68	0.79	0.89	112.9	6.39	0.69	0.8	0.91	107.4	7.17	0.69	0.81	0.92	101.4	8.06	0.7	0.82	0.94
	6500	124	5.77	0.71	0.82	0.94	118.4	6.46	0.71	0.84	0.95	112.1	7.24	0.72	0.85	0.97	105.8	8.13	0.73	0.87	0.99
67°F	4500	118.3	5.69	0.54	0.63	0.72	113.3	6.4	0.54	0.63	0.73	107.7	7.17	0.54	0.64	0.73	102	8.07	0.53	0.64	0.74
	5500	126	5.79	0.55	0.66	0.76	120.4	6.49	0.55	0.66	0.77	114.7	7.28	0.55	0.67	0.78	108.3	8.16	0.56	0.67	0.79
	6500	131.9	5.87	0.57	0.68	0.79	125.7	6.56	0.57	0.69	0.8	119.7	7.34	0.57	0.7	0.82	112.8	8.21	0.57	0.71	0.84
71°F	4500	125.8	5.79	0.43	0.52	0.6	120.4	6.48	0.42	0.52	0.61	114.8	7.27	0.42	0.52	0.61	108.7	8.16	0.41	0.52	0.61
	5500	133.7	5.89	0.43	0.53	0.63	128	6.6	0.43	0.54	0.64	121.6	7.37	0.43	0.53	0.64	115.3	8.26	0.42	0.54	0.65
	6500	139.7	5.98	0.44	0.55	0.66	133.6	6.68	0.44	0.55	0.67	126.6	7.44	0.43	0.55	0.67	119.9	8.33	0.43	0.56	0.69

20 TON COOLING STANDARD EFFICIENCY KHA240S4 (2ND STAGE) - MSAV (Multi-Stage Air Volume) SUPPLY AIR BLOWER

Entering Wet Bulb Temperature	Total Air Volume	Outdoor Air Temperature Entering Outdoor Coil																			
		85°F					95°F					105°F					115°F				
		Total Cool Cap.	Comp. Motor Input	Sensible To Total Ratio (S/T) Dry Bulb			Total Cool Cap.	Comp. Motor Input	Sensible To Total Ratio (S/T) Dry Bulb			Total Cool Cap.	Comp. Motor Input	Sensible To Total Ratio (S/T) Dry Bulb			Total Cool Cap.	Comp. Motor Input	Sensible To Total Ratio (S/T) Dry Bulb		
				75°F	80°F	85°F			75°F	80°F	85°F			75°F	80°F	85°F			75°F	80°F	85°F
cfm	kBtuh	kW	75°F	80°F	85°F	kBtuh	kW	75°F	80°F	85°F	kBtuh	kW	75°F	80°F	85°F	kBtuh	kW	75°F	80°F	85°F	
63°F	6400	217.2	14.54	0.73	0.86	0.98	204.3	16.3	0.74	0.88	0.99	191.1	18.32	0.76	0.9	1	176.2	20.62	0.78	0.93	1
	8000	228.1	14.7	0.78	0.93	1	214.9	16.46	0.8	0.95	1	200.6	18.46	0.82	0.98	1	185.6	20.76	0.84	1	1
	9600	236.9	14.84	0.83	0.99	1	223.5	16.59	0.85	1	1	209.8	18.61	0.88	1	1	195	20.91	0.91	1	1
67°F	6400	231.5	14.73	0.57	0.71	0.83	217.9	16.51	0.58	0.72	0.85	204.1	18.53	0.58	0.73	0.87	188.1	20.81	0.59	0.75	0.9
	8000	242.6	14.93	0.61	0.76	0.9	228.5	16.67	0.61	0.78	0.92	213.5	18.68	0.62	0.8	0.95	196.4	20.93	0.64	0.82	0.98
	9600	251	15.07	0.64	0.82	0.96	236.1	16.79	0.65	0.83	0.98	219.7	18.78	0.67	0.86	1	202.2	21.04	0.68	0.89	1
71°F	6400	245.5	14.97	0.44	0.56	0.68	231.7	16.72	0.43	0.56	0.69	216.8	18.73	0.43	0.57	0.71	200.2	21.02	0.43	0.58	0.73
	8000	257.1	15.17	0.45	0.6	0.74	242.3	16.9	0.45	0.6	0.75	226.2	18.89	0.45	0.61	0.78	208.8	21.15	0.45	0.63	0.8
	9600	265.7	15.31	0.46	0.63	0.79	249.9	17.03	0.46	0.64	0.81	233.2	19.01	0.47	0.66	0.84	215	21.27	0.47	0.67	0.87

20 TON HEATING STANDARD EFFICIENCY KHA240S4 - MSAV (Multi-Stage Air Volume) SUPPLY AIR BLOWER

Indoor Coil Air Volume 70°F Dry Bulb cfm	Air Temperature Entering Outdoor Coil									
	65°F		45°F		25°F		5°F		-15°F	
	Total Heating Capacity	Comp. Motor Input	Total Heating Capacity	Comp. Motor Input	Total Heating Capacity	Comp. Motor Input	Total Heating Capacity	Comp. Motor Input	Total Heating Capacity	Comp. Motor Input
6400	256.9	16.68	209.9	15.53	135.3	14.39	96.7	12.59	46.3	9450
8000	262.3	15.67	215.3	14.52	140.3	13.38	101.3	11.59	51.0	8450
9600	267.6	15.04	220.6	13.89	145.3	12.76	106.1	10.98	55.8	7840

BLOWER DATA

BLOWER TABLE INCLUDES RESISTANCE FOR BASE UNIT ONLY WITH DRY INDOOR COIL & AIR FILTERS IN PLACE

FOR ALL UNITS ADD:

- 1 - Wet indoor coil air resistance of selected unit.
- 2 - Any factory installed options air resistance (electric heat, economizer, etc.)
- 3 - Any field installed accessories air resistance (electric heat, duct resistance, diffuser, etc.)

Then determine from blower table blower motor output and drive required.

See page 17 for wet coil and option/accessory air resistance data.

See page 17 for factory installed drive kit specifications.

MINIMUM AIR VOLUME REQUIRED FOR USE WITH OPTIONAL ELECTRIC HEAT

All units require 6000 cfm minimum air with electric heat.

Air Volume cfm	TOTAL STATIC PRESSURE - Inches Water Gauge (Pa)																									
	0.20		0.40		0.60		0.80		1.00		1.20		1.40		1.60		1.80		2.00		2.20		2.40		2.60	
	RPM	BHP	RPM	BHP	RPM	BHP	RPM	BHP	RPM	BHP	RPM	BHP	RPM	BHP	RPM	BHP	RPM	BHP	RPM	BHP	RPM	BHP	RPM	BHP	RPM	BHP
3250	405	0.40	520	0.60	615	0.85	695	1.10	765	1.30	830	1.60	890	1.85	950	2.10	1005	2.35	1065	2.60	1115	2.85	1165	3.10	1215	3.35
3500	415	0.45	530	0.70	620	0.95	700	1.20	775	1.45	840	1.70	900	2.00	965	2.25	1025	2.50	1085	2.75	1140	3.00	1195	3.25	1250	3.50
3750	425	0.50	540	0.75	630	1.05	710	1.30	780	1.60	845	1.85	905	2.15	970	2.40	1030	2.65	1090	2.90	1145	3.15	1200	3.40	1255	3.65
4000	435	0.55	545	0.85	635	1.10	715	1.40	785	1.70	850	2.00	910	2.30	975	2.55	1035	2.80	1095	3.05	1150	3.30	1205	3.55	1260	3.80
4250	445	0.60	555	0.90	645	1.25	725	1.55	795	1.85	855	2.15	915	2.45	980	2.70	1040	2.95	1100	3.20	1155	3.45	1210	3.70	1265	3.95
4500	455	0.70	565	1.00	655	1.35	730	1.65	800	2.00	865	2.35	925	2.65	990	2.90	1050	3.15	1110	3.40	1165	3.65	1220	3.90	1275	4.15
4750	470	0.75	575	1.10	660	1.45	740	1.80	810	2.15	870	2.50	930	2.85	995	3.10	1055	3.35	1115	3.60	1170	3.85	1225	4.10	1280	4.35
5000	480	0.85	585	1.25	670	1.60	750	1.95	815	2.30	880	2.70	940	3.05	1000	3.30	1060	3.55	1120	3.80	1175	4.05	1230	4.30	1285	4.55
5250	495	0.95	595	1.35	680	1.70	755	2.10	825	2.50	890	2.90	945	3.25	1000	3.50	1060	3.70	1120	4.00	1175	4.30	1230	4.55	1285	4.80
5500	505	1.05	605	1.45	690	1.85	765	2.25	835	2.65	895	3.05	955	3.45	1010	3.75	1070	3.95	1130	4.20	1185	4.45	1240	4.70	1290	4.95
5750	520	1.15	615	1.60	700	2.00	775	2.45	840	2.85	905	3.25	960	3.65	1015	4.00	1075	4.20	1135	4.45	1190	4.70	1245	4.95	1295	5.15
6000	530	1.30	630	1.75	710	2.15	785	2.60	850	3.05	910	3.45	970	3.90	1025	4.25	1085	4.40	1140	4.65	1200	4.90	1255	5.15	1305	5.35
6250	545	1.40	640	1.90	720	2.35	795	2.80	860	3.25	920	3.70	975	4.15	1030	4.50	1090	4.65	1145	4.90	1200	5.15	1255	5.35	1305	5.55
6500	560	1.55	650	2.05	730	2.50	805	3.00	870	3.45	930	3.95	985	4.40	1040	4.75	1095	4.90	1150	5.15	1205	5.40	1260	5.60	1310	5.80
6750	570	1.70	665	2.20	745	2.70	815	3.20	880	3.70	940	4.20	995	4.65	1045	5.00	1100	5.15	1155	5.40	1205	5.65	1260	5.85	1310	6.05
7000	585	1.85	675	2.35	755	2.90	825	3.40	890	3.95	950	4.45	1005	4.90	1055	5.20	1110	5.35	1165	5.60	1215	5.85	1270	6.05	1320	6.25
7250	600	2.00	690	2.60	765	3.10	835	3.65	900	4.15	955	4.65	1015	5.10	1065	5.40	1120	5.55	1175	5.80	1225	6.05	1280	6.25	1330	6.45
7500	615	2.20	700	2.75	775	3.30	845	3.85	910	4.45	965	4.95	1020	5.40	1075	5.70	1130	5.85	1185	6.10	1235	6.30	1290	6.50	1340	6.70
7750	630	2.40	715	3.00	790	3.55	855	4.10	920	4.70	975	5.25	1030	5.70	1080	6.00	1135	6.15	1190	6.40	1240	6.60	1295	6.80	1345	7.00
8000	640	2.55	725	3.20	800	3.80	865	4.35	930	4.95	985	5.50	1040	6.00	1090	6.30	1145	6.45	1200	6.70	1250	6.90	1305	7.10	1350	7.30
8250	655	2.80	740	3.40	810	4.00	880	4.65	940	5.25	995	5.85	1050	6.30	1100	6.60	1155	6.75	1210	7.00	1260	7.20	1315	7.40	1360	7.60
8500	670	3.00	750	3.65	825	4.30	890	4.90	950	5.55	1005	6.15	1060	6.60	1110	6.90	1165	7.05	1220	7.30	1270	7.50	1325	7.70	1370	7.90
8750	685	3.25	765	3.90	835	4.55	900	5.20	960	5.85	1015	6.45	1070	7.00	1120	7.25	1175	7.40	1230	7.70	1280	7.90	1335	8.10	1380	8.30
9000	700	3.50	780	4.20	850	4.85	910	5.50	970	6.15	1025	6.80	1080	7.50	1130	7.75	1185	7.90	1240	8.20	1290	8.40	1345	8.60	1390	8.80
9250	715	3.75	790	4.45	860	5.15	925	5.85	985	6.55	1040	7.20	1095	7.85	1140	8.05	1195	8.20	1250	8.50	1300	8.70	1355	8.90	1400	9.10
9500	730	4.00	805	4.75	875	5.45	935	6.15	995	6.90	1050	7.60	1100	8.25	1150	8.50	1205	8.70	1260	9.00	1310	9.20	1365	9.40	1410	9.60
9750	745	4.30	820	5.05	885	5.75	950	6.55	1005	7.20	1060	7.95	1110	8.65	1160	8.90	1215	9.10	1270	9.40	1320	9.60	1375	9.80	1420	10.00
10,000	760	4.60	835	5.40	900	6.15	960	6.85	1015	7.60	1070	8.35	1120	9.05	1170	9.30	1225	9.50	1280	9.80	1330	10.00	1385	10.20	1430	10.40
10,250	775	4.90	845	5.65	910	6.45	970	7.20	1030	8.00	1080	8.75	1135	9.55	1180	10.25	1235	11.00	1290	11.75	1340	12.50	1395	13.25	1445	14.00
10,500	790	5.20	860	6.00	925	6.85	985	7.65	1040	8.40	1095	9.20	1145	10.00	1190	10.70	1245	11.45	1300	12.20	1350	13.00	1405	13.75	1455	14.50
10,750	805	5.55	875	6.40	940	7.25	1000	8.05	1055	8.85	1105	9.65	1155	10.45	1200	11.20	1255	12.25	1310	13.05	1360	13.85	1415	14.60	1465	15.30
11,000	820	5.90	890	6.80	950	7.60	1010	8.45	1065	9.30	1115	10.05	1165	10.90	1210	11.90	1265	13.15	1320	14.00	1370	14.85	1425	15.55	1475	16.05

BLOWER DATA

FACTORY INSTALLED BELT DRIVE KIT SPECIFICATIONS

Nominal hp	Maximum hp	Drive Kit Number	RPM Range
3	3.45	1	535 - 725
3	3.45	2	710 - 965
5	5.75	3	685 - 856
5	5.75	4	850 - 1045
5	5.75	5	945 - 1185
7.5	8.63	6	850 - 1045
7.5	8.63	7	945 - 1185
7.5	8.63	8	1045 - 1285
10	11.50	7	945 - 1185
10	11.50	10	1045 - 1285
10	11.50	11	1135 - 1365

NOTE - Using total air volume and system static pressure requirements determine from blower performance tables rpm and motor output required. Maximum usable output of motors furnished are shown. In Canada, nominal motor output is also maximum usable motor output. If motors of comparable output are used, be sure to keep within the service factor limitations outlined on the motor nameplate.

NOTE - All models are limited to a motor service factor of 1.0.

FACTORY INSTALLED OPTIONS/FIELD INSTALLED ACCESSORY AIR RESISTANCE - in. w.g.

Air Volume cfm	Wet Indoor Coil		Electric Heat	Economizer	Filters		Horizontal Roof Curb
	180S	240S			MERV 8	MERV 13	
3250	0.02	0.03	---	---	0.01	0.04	0.04
3500	0.02	0.03	---	---	0.01	0.04	0.05
3750	0.02	0.03	---	---	0.01	0.04	0.05
4000	0.02	0.04	---	---	0.01	0.04	0.06
4250	0.02	0.04	---	---	0.01	0.05	0.07
4500	0.02	0.05	---	---	0.01	0.05	0.07
4750	0.02	0.05	---	---	0.02	0.05	0.08
5000	0.03	0.05	---	---	0.02	0.06	0.08
5250	0.03	0.06	---	---	0.02	0.06	0.09
5500	0.03	0.07	---	---	0.02	0.06	0.10
5750	0.03	0.07	---	---	0.02	0.07	0.11
6000	0.04	0.08	0.01	---	0.03	0.07	0.11
6250	0.04	0.08	0.01	0.01	0.03	0.07	0.12
6500	0.04	0.09	0.01	0.02	0.03	0.08	0.13
6750	0.05	0.10	0.01	0.03	0.03	0.08	0.14
7000	0.05	0.10	0.01	0.04	0.04	0.08	0.15
7250	0.06	0.11	0.01	0.05	0.04	0.09	0.16
7500	0.06	0.12	0.01	0.06	0.04	0.09	0.17
8000	0.07	0.13	0.02	0.09	0.05	0.10	0.19
8500	0.08	0.15	0.02	0.11	0.05	0.10	0.21
9000	0.09	0.16	0.04	0.14	0.06	0.11	0.24
9500	0.10	0.18	0.05	0.16	0.07	0.12	0.26
10,000	0.11	0.20	0.06	0.19	0.07	0.12	0.29
10,500	0.12	0.22	0.09	0.22	0.08	0.13	0.31
11,000	0.14	0.24	0.11	0.25	0.09	0.14	0.34

BLOWER DATA

CEILING DIFFUSER AIR RESISTANCE - in. w.g.

Air Volume cfm	Step-Down Diffuser						Flush Diffuser	
	RTD11-185S			RTD11-275			FD11-185S	FD11-275
	2 Ends Open	1 Side/2 Ends Open	All Ends & Sides Open	2 Ends Open	1 Side/2 Ends Open	All Ends & Sides Open		
5000	.51	.44	.39	---	---	---	.27	---
5200	.56	.48	.42	---	---	---	.30	---
5400	.61	.52	.45	---	---	---	.33	---
5600	.66	.56	.48	---	---	---	.36	---
5800	.71	.59	.51	---	---	---	.39	---
6000	.76	.63	.55	.36	.31	.27	.42	.29
6200	.80	.68	.59	---	---	---	.46	---
6400	.86	.72	.63	---	---	---	.50	---
6500	---	---	---	.42	.36	.31	---	.34
6600	.92	.77	.67	---	---	---	.54	---
6800	.99	.83	.72	---	---	---	.58	---
7000	1.03	.87	.76	.49	.41	.36	.62	.40
7200	1.09	.92	.80	---	---	---	.66	---
7400	1.15	.97	.84	---	---	---	.70	---
7500	---	---	---	.51	.46	.41	---	.45
7600	1.20	1.02	.88	---	---	---	.74	---
8000	---	---	---	.59	.49	.43	---	.50
8500	---	---	---	.69	.58	.50	---	.57
9000	---	---	---	.79	.67	.58	---	.66
9500	---	---	---	.89	.75	.65	---	.74
10,000	---	---	---	1.00	.84	.73	---	.81
10,500	---	---	---	1.10	.92	.80	---	.89
11,000	---	---	---	1.21	1.01	.88	---	.96

CEILING DIFFUSER AIR THROW DATA

Model No.	Air Volume cfm	¹ Effective Throw Range - ft.		Model No.	Air Volume cfm	¹ Effective Throw Range - ft.	
		RTD11-185S Step-Down	FD11-185S Flush			RTD11-275 Step-Down	FD11-275 Flush
180	5600	39 - 49	28 - 37	240	7200	33 - 38	26 - 35
	5800	42 - 51	29 - 38		7400	35 - 40	28 - 37
	6000	44 - 54	40 - 50		7600	36 - 41	29 - 38
	6200	45 - 55	42 - 51		7800	38 - 43	40 - 50
	6400	46 - 55	43 - 52		8000	39 - 44	42 - 51
	6600	47 - 56	45 - 56		8200	41 - 46	43 - 52
					8400	43 - 49	44 - 54
					8600	44 - 50	46 - 57
					8800	47 - 55	48 - 59

¹ Throw is the horizontal or vertical distance an airstream travels on leaving the outlet or diffuser before the maximum velocity is reduced to 50 ft. per minute. Four sides open.

POWER EXHAUST FAN PERFORMANCE

Return Air System Static Pressure	Air Volume Exhausted
in. w.g.	cfm
0.00	8630
0.05	8210
0.10	7725
0.15	7110
0.20	6470
0.25	5790
0.30	5060
0.35	4300
0.40	3510
0.45	2690
0.50	1840

ELECTRICAL/ELECTRIC HEAT DATA

STANDARD EFFICIENCY - 15 TON

Model No.		KHA180S4M								
¹ Voltage - 60hz		208/230V - 3 Ph			460V - 3 Ph			575V - 3 Ph		
Compressor 1	Rated Load Amps	25			12.2			9		
	Locked Rotor Amps	164			100			78		
Compressor 2	Rated Load Amps	25			12.2			9		
	Locked Rotor Amps	164			100			78		
Outdoor Fan Motors (4)	Full Load Amps	2.4			1.3			1		
	(total)	(9.6)			(5.2)			(4)		
Power Exhaust (2) 0.33 HP	Full Load Amps	2.4			1.3			1		
	(total)	(4.8)			(2.6)			(2)		
Service Outlet 115V GFI (amps)		15			15			20		
Indoor Blower Motor	Horsepower	3	5	7.5	3	5	7.5	3	5	7.5
	Full Load Amps	10.6	16.7	24.2	4.8	7.6	11	3.9	6.1	9
² Maximum Overcurrent Protection	Unit Only	100	100	110	45	50	50	35	35	40
	With (2) 0.33 HP Power Exhaust	100	110	110	50	50	50	35	40	40
³ Minimum Circuit Ampacity	Unit Only	77	83	91	38	41	44	29	31	34
	With (2) 0.33 HP Power Exhaust	82	88	95	41	43	47	31	33	36

ELECTRIC HEAT DATA

Electric Heat Voltage			208V	240V	208V	240V	208V	240V	480V	480V	480V	600V	600V	600V
² Maximum Overcurrent Protection	Unit+ Electric Heat	15 kW	125	125	125	150	150	150	70	70	70	50	50	60
		30 kW	175	175	175	175	175	200	90	90	90	70	70	70
		45 kW	200	225	200	225	225	250	110	110	125	90	90	90
		60 kW	225	225	225	250	225	250	110	125	125	90	90	100
³ Minimum Circuit Ampacity	Unit+ Electric Heat	15 kW	116	122	122	128	130	136	61	63	67	47	49	52
		30 kW	155	167	161	173	169	181	83	86	89	65	67	70
		45 kW	194	212	200	218	208	226	106	108	112	83	85	88
		60 kW	202	221	208	227	216	235	110	113	116	86	89	91
² Maximum Overcurrent Protection	Unit+ Electric Heat and (2) 0.33 HP Power Exhaust	15 kW	125	150	150	150	150	150	70	70	70	50	60	60
		30 kW	175	175	175	200	175	200	90	90	100	70	70	80
		45 kW	200	225	225	225	225	250	110	125	125	90	90	90
		60 kW	225	250	225	250	225	250	125	125	125	90	100	100
³ Minimum Circuit Ampacity	Unit+ Electric Heat and (2) 0.33 HP Power Exhaust	15 kW	121	127	127	133	134	140	63	66	69	49	51	54
		30 kW	160	172	166	178	174	186	86	88	92	67	69	72
		45 kW	199	217	205	223	213	231	108	111	114	85	87	90
		60 kW	207	226	213	232	220	240	113	116	119	88	91	93

ELECTRICAL ACCESSORIES

Disconnect	Unit Only	54W86	54W86	54W86	54W86	54W86	54W86	54W86	54W85	54W85	54W85	54W85	54W85	54W85
	Unit + Power Exhaust	54W86	54W86	54W86	54W86	54W86	54W86	54W86	54W85	54W85	54W85	54W85	54W85	54W85
	Unit + Electric Heat 15 kW	54W86	54W86	54W86	54W86	54W86	54W86	54W86	54W85	54W85	54W85	54W85	54W85	54W85
	Unit + Electric Heat 30 kW	54W87	54W87	54W87	54W87	54W87	54W87	54W87	54W85	54W85	54W86	54W85	54W85	54W85
	Unit + Electric Heat 45 kW	54W87	54W87	54W87	54W87	54W87	54W87	54W87	54W86	54W86	54W86	54W85	54W85	54W86
	Unit + Electric Heat 60 kW	54W87	54W87	54W87	54W87	54W87	54W87	54W87	54W86	54W86	54W86	54W86	54W86	54W86
	Unit + Power Exhaust + Elec. Heat 15 kW	54W86	54W86	54W86	54W86	54W86	54W86	54W86	54W85	54W85	54W85	54W85	54W85	54W85
	Unit + Power Exhaust + Elec. Heat 30 kW	54W87	54W87	54W87	54W87	54W87	54W87	54W87	54W85	54W86	54W86	54W85	54W85	54W85
	Unit + Power Exhaust + Elec. Heat 45 kW	54W87	54W87	54W87	54W87	54W87	54W87	54W87	54W86	54W86	54W86	54W85	54W85	54W86
	Unit + Power Exhaust + Elec. Heat 60 kW	54W87	54W87	54W87	54W87	54W87	54W87	54W87	54W86	54W86	54W86	54W86	54W86	54W86
			54W86	54W86	54W86	54W86	54W86	54W86	54W85	54W85	54W85	54W85	54W85	54W85
			54W87	54W87	54W87	54W87	54W87	54W87	54W85	54W86	54W86	54W85	54W85	54W85
			54W87	54W87	54W87	54W87	54W87	54W87	54W86	54W86	54W86	54W86	54W86	54W86
			54W87	54W87	54W87	54W87	54W87	54W87	54W86	54W86	54W86	54W86	54W86	54W86

NOTE - All units have a minimum Short Circuit Current Rating (SCCR) of 5000 amps.

¹ Extremes of operating range are plus and minus 10% of line voltage.

² HACR type breaker or fuse.

³ Refer to National or Canadian Electrical Code manual to determine wire, fuse and disconnect size requirements.

⁴ Disconnect must be field furnished.

ELECTRICAL/ELECTRIC HEAT DATA

STANDARD EFFICIENCY - 20 TON

Model No.		KHA240S4M								
¹ Voltage - 60hz		208/230V - 3 Ph			460V - 3 Ph			575V - 3 Ph		
Compressor 1	Rated Load Amps	30.1			16.7			12.2		
	Locked Rotor Amps	225			114			80		
Compressor 2	Rated Load Amps	30.1			16.7			12.2		
	Locked Rotor Amps	225			114			80		
Outdoor Fan Motors (4)	Full Load Amps	2.4			1.3			1		
	(total)	(9.6)			(5.2)			(4)		
Power Exhaust (2) 0.33 HP	Full Load Amps	2.4			1.3			1		
	(total)	(4.8)			(2.6)			(2)		
Service Outlet 115V GFI (amps)		15			15			20		
Indoor Blower Motor	Horsepower	5	7.5	10	5	7.5	10	5	7.5	10
	Full Load Amps	16.7	24.2	30.8	7.6	11	14	6.1	9	11
² Maximum Overcurrent Protection	Unit Only	110	125	125	60	70	70	45	50	50
	With (2) 0.33 HP Power Exhaust	125	125	125	60	70	70	50	50	50
³ Minimum Circuit Ampacity	Unit Only	95	102	109	51	54	57	38	41	43
	With (2) 0.33 HP Power Exhaust	99	107	114	53	57	60	40	43	45

ELECTRIC HEAT DATA

Electric Heat Voltage			208V	240V	208V	240V	208V	240V	480V	480V	480V	600V	600V	600V
² Maximum Overcurrent Protection	Unit+ Electric Heat	15 kW	150	150	150	150	150	175	80	80	90	60	60	70
		30 kW	175	200	200	200	200	200	100	100	110	80	80	80
		45 kW	225	250	225	250	250	250	125	125	125	100	100	100
		60 kW	225	250	250	250	250	300	125	150	150	100	110	110
		90 kW	300	350	300	350	300	350	175	175	175	125	150	150
³ Minimum Circuit Ampacity	Unit+ Electric Heat	15 kW	134	140	141	147	148	154	73	77	80	56	59	61
		30 kW	173	185	180	192	187	199	96	99	102	74	77	79
		45 kW	212	230	219	237	226	244	119	122	125	92	95	97
		60 kW	220	239	227	246	234	253	123	126	129	96	99	101
		90 kW	282	311	290	319	296	325	159	163	166	125	128	130
² Maximum Overcurrent Protection	Unit+ Electric Heat and (2) 0.33 HP Power Exhaust	15 kW	150	150	150	175	175	175	80	90	90	60	70	70
		30 kW	200	200	200	200	200	225	100	110	110	80	80	90
		45 kW	225	250	225	250	250	250	125	125	150	100	100	100
		60 kW	250	250	250	300	250	300	150	150	150	100	110	110
		90 kW	300	350	300	350	350	350	175	175	175	150	150	150
³ Minimum Circuit Ampacity	Unit+ Electric Heat and (2) 0.33 HP Power Exhaust	15 kW	138	144	146	152	153	159	76	79	82	58	61	63
		30 kW	178	190	185	197	192	204	99	102	105	76	79	81
		45 kW	217	235	224	242	231	249	121	125	128	94	97	99
		60 kW	224	244	232	251	239	258	126	129	132	98	101	103
		90 kW	287	316	294	323	301	330	162	165	168	127	130	132

ELECTRICAL ACCESSORIES

Disconnect	Unit Only	54W86	54W86	54W86	54W86	54W86	54W86	54W86	54W85	54W85	54W85	54W85	54W85	54W85
	Unit + Power Exhaust	54W86	54W86	54W86	54W86	54W86	54W86	54W86	54W85	54W85	54W85	54W85	54W85	54W85
	Unit + Electric Heat 15 kW	54W86	54W86	54W86	54W86	54W86	54W86	54W86	54W85	54W85	54W85	54W85	54W85	54W85
	Unit + Electric Heat 30 kW	54W87	54W87	54W87	54W87	54W87	54W87	54W86	54W86	54W86	54W85	54W85	54W85	54W85
	Unit + Electric Heat 45 kW	54W87	54W87	54W87	54W87	54W87	54W87	54W86	54W86	54W86	54W86	54W86	54W86	54W86
	Unit + Electric Heat 60 kW	⁴ N/A	⁴ N/A	⁴ N/A	⁴ N/A	⁴ N/A	⁴ N/A	54W86	54W86	54W86	54W86	54W86	54W86	54W86
	Unit + Electric Heat 90 kW	⁴ N/A	⁴ N/A	⁴ N/A	⁴ N/A	⁴ N/A	⁴ N/A	54W87	54W87	54W87	54W86	54W86	54W86	54W86
	Unit + Power Exhaust + Elec. Heat 15 kW	54W86	54W86	54W86	54W86	54W87	54W87	54W85	54W85	54W85	54W85	54W85	54W85	54W85
	Unit + Power Exhaust + Elec. Heat 30 kW	54W87	54W87	54W87	54W87	54W87	54W87	54W86	54W86	54W86	54W85	54W85	54W85	54W85
	Unit + Power Exhaust + Elec. Heat 45 kW	54W87	54W87	54W87	54W87	54W87	54W87	54W86	54W86	54W86	54W86	54W86	54W86	54W86
Unit + Power Exhaust + Elec. Heat 60 kW	⁴ N/A	⁴ N/A	⁴ N/A	⁴ N/A	⁴ N/A	⁴ N/A	54W86	54W86	54W86	54W86	54W86	54W86	54W86	
Unit + Power Exhaust + Elec. Heat 90 kW	⁴ N/A	⁴ N/A	⁴ N/A	⁴ N/A	⁴ N/A	⁴ N/A	54W87	54W87	54W87	54W86	54W86	54W86	54W86	

NOTE - All units have a minimum Short Circuit Current Rating (SCCR) of 5000 amps.

¹ Extremes of operating range are plus and minus 10% of line voltage.

² HACR type breaker or fuse.

³ Refer to National or Canadian Electrical Code manual to determine wire, fuse and disconnect size requirements.

⁴ Disconnect must be field furnished.

ELECTRIC HEAT CAPACITIES

Volts Input	15 kW			30 kW			45 kW			60 kW			90 kW		
	kW Input	Btuh Output	No. of Stages	kW Input	Btuh Output	No. of Stages	kW Input	Btuh Output	No. of Stages	kW Input	Btuh Output	No. of Stages	kW Input	Btuh Output	No. of Stages
208	11.3	38,600	1	22.5	76,800	1	33.8	115,300	2	45.0	153,600	2	67.6	230,700	2
220	12.6	43,000	1	25.2	86,000	1	37.8	129,000	2	50.4	172,000	2	75.6	258,000	2
230	13.8	47,100	1	27.5	93,900	1	41.3	141,000	2	55.1	188,000	2	82.7	282,200	2
240	15.0	51,200	1	30.0	102,400	1	45.0	153,600	2	60.0	204,800	2	90.0	307,100	2
440	12.6	43,000	1	25.2	86,000	1	37.8	129,000	2	50.4	172,000	2	75.6	258,000	2
460	13.8	47,100	1	27.5	93,900	1	41.3	141,000	2	55.1	188,000	2	82.7	282,200	2
480	15.0	51,200	1	30.0	102,400	1	45.0	153,600	2	60.0	204,800	2	90.0	307,100	2
550	12.6	43,000	1	25.2	86,000	1	37.8	129,000	2	50.4	172,000	2	75.6	258,000	2
575	13.8	47,100	1	27.5	93,900	1	41.3	141,000	2	55.1	188,000	2	82.7	282,200	2
600	15.0	51,200	1	30.0	102,400	1	45.0	153,600	2	60.0	204,800	2	90.0	307,100	2

UNIT CLEARANCES

Unit With Economizer

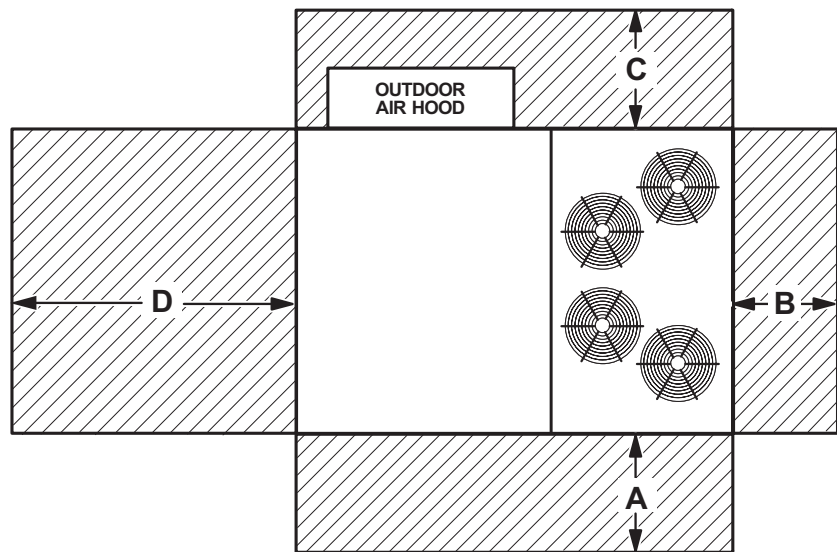

¹ Unit Clearance	A		B		C		D		Top Clearance
	in.	mm	in.	mm	in.	mm	in.	mm	
Service Clearance	60	1524	36	914	36	914	66	1676	Unobstructed
Minimum Operation Clearance	45	1143	36	914	36	914	41	1041	

NOTE - Entire perimeter of unit base requires support when elevated above the mounting surface.

¹ Service Clearance - Required for removal of serviceable parts.

Minimum Operation Clearance - Required clearance for proper unit operation.

OUTDOOR SOUND DATA

Unit Model Number	Octave Band Sound Power Levels dBA, re 10 ⁻¹² Watts - Center Frequency - Hz							¹ Sound Rating Number (dBA)
	125	250	500	1000	2000	4000	8000	
KHA180 Cooling	75	81	87	89	86	81	69	93
KHA180 Heating	76	81	87	89	87	81	70	93
KHA240 Cooling	77	81	87	89	86	80	67	93
KHA240 Heating	78	81	88	89	87	81	67	93

NOTE - The octave sound power data does not include tonal corrections.

¹ Sound Rating Number according to AHRI Standard 370-2001 (includes pure tone penalty). Sound Rating Number is the overall A-Weighted Sound Power Level, (LWA), dB (100 Hz to 10,000 Hz).

WEIGHT DATA

Model Number	Net		Shipping	
	lbs.	kg	lbs.	kg
180 Base Unit	1950	885	2150	975
180 Max. Unit	2270	1030	2470	1120
240 Base Unit	2150	975	2350	1066
240 Max. Unit	2480	1125	2680	1216

Max. Unit - The unit with ALL INTERNAL OPTIONS Installed. (Economizer, Standard Static Power Exhaust Fans, Controls, etc.). Does not include accessories external to unit.

OPTIONS / ACCESSORIES

Description	Shipping Weight	
	lbs.	kg
ECONOMIZER / OUTDOOR AIR / EXHAUST		
Economizer		
Economizer Dampers	102	46
Barometric Relief Dampers (downflow)	30	14
Barometric Relief Dampers (horizontal)	20	9
Outdoor Air Damper Hood (downflow)	65	29
Outdoor Air Dampers		
Outdoor Air Damper Section (downflow) - Automatic (including Hood)	18	39
Outdoor Air Damper Section (downflow) - Manual (including Hood)	10	22
Power Exhaust	62	28
ELECTRIC HEAT		
15 kW	59	27
30 kW	59	27
45 kW	76	34
60 kW	76	34
90 kW	84	38
MSAV (MULTI-STAGE AIR VOLUME) SUPPLY AIR BLOWER OPTION		
Variable Frequency Drive (VFD) and associated components	10	5
ROOF CURBS		
Hybrid Roof Curbs, Downflow		
8 in. height	75	34
14 in. height	105	48
18 in. height	125	57
24 in. height	155	70
Adjustable Pitch Curb, Downflow		
14 in. height	262	119
Horizontal Roof Curbs, Standard		
26 in. height	420	191
37 in. height	580	263
CEILING DIFFUSERS		
Step-Down		
RTD11-185S	168	76
RTD11-275S	238	108
Flush		
FD11-185S	168	76
FD11-275S	238	108
Transitions		
C1DIFF33C-1	80	36
C1DIFF34C-1	75	34
PACKAGING		
LTL Packaging (less than truck load)	310	141

DIMENSIONS - UNIT

CORNER WEIGHTS

Model No.	AA		BB		CC		DD		CENTER OF GRAVITY		FF	
	lbs.	kg	lbs.	kg	lbs.	kg	lbs.	kg	in.	mm	in.	mm
KHA180 Std. Unit	385	182	466	220	602	284	497	235	59	1499	39-3/4	1010
KHA180 Max. Unit	492	232	548	258	648	306	582	275	56-3/4	1441	41-3/4	1060
KHA240 Std. Unit	423	199	497	235	665	314	565	267	58-1/4	1480	39	991
KHA240 Max. Unit	536	253	580	274	709	335	655	309	56	1422	41	1041

Std. Unit - The unit with NO INTERNAL OPTIONS.

Max. Unit - The unit with ALL INTERNAL OPTIONS Installed. (Economizer, Standard Static Power Exhaust Fans, Controls, etc.). Does not include accessories external to unit.

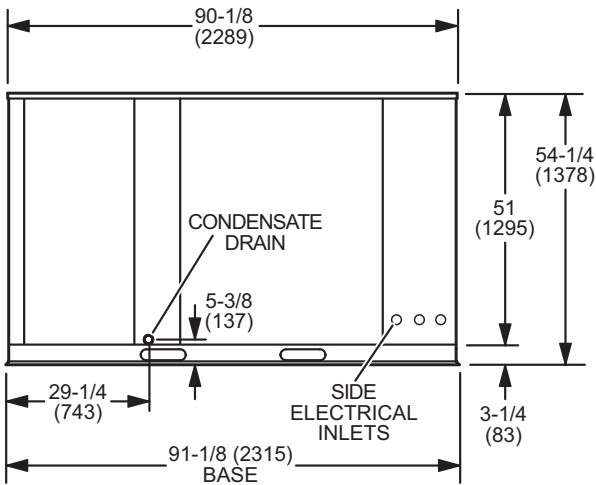
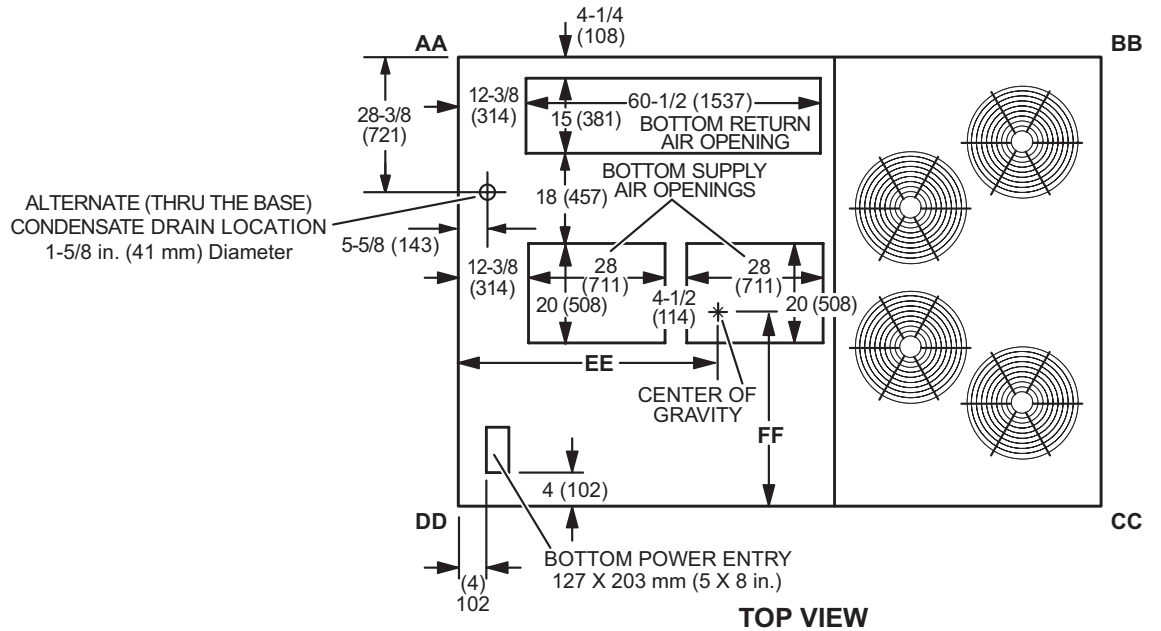

END VIEW

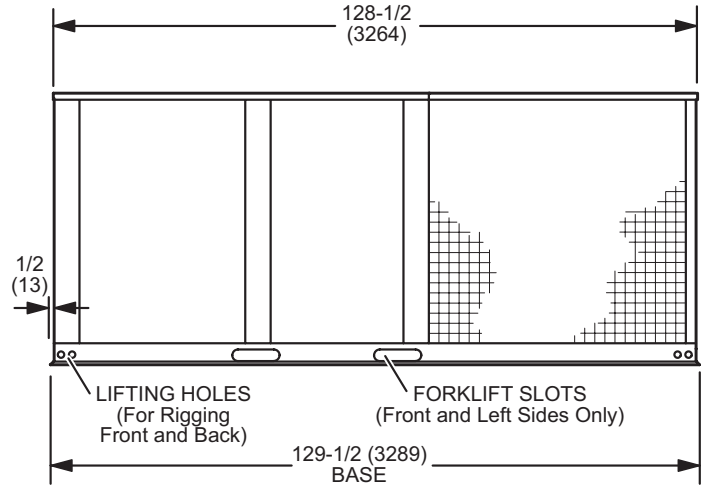

SIDE VIEW

OUTDOOR AIR HOOD DETAIL

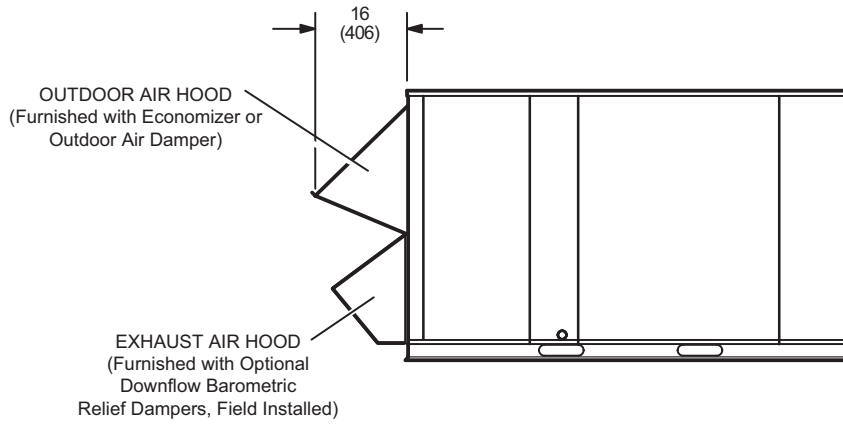

OPTIONAL HORIZONTAL BAROMETRIC RELIEF DAMPERS WITH HOOD

(Field installed in horizontal return air duct adjacent to unit)

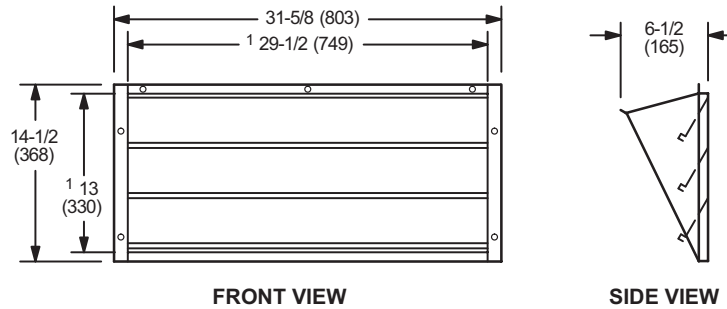

NOTE - Two furnished per order no.
 1 NOTE - Opening size required in return air duct.

DIMENSIONS - ACCESSORIES

HYBRID ROOF CURBS - DOUBLE DUCT OPENING

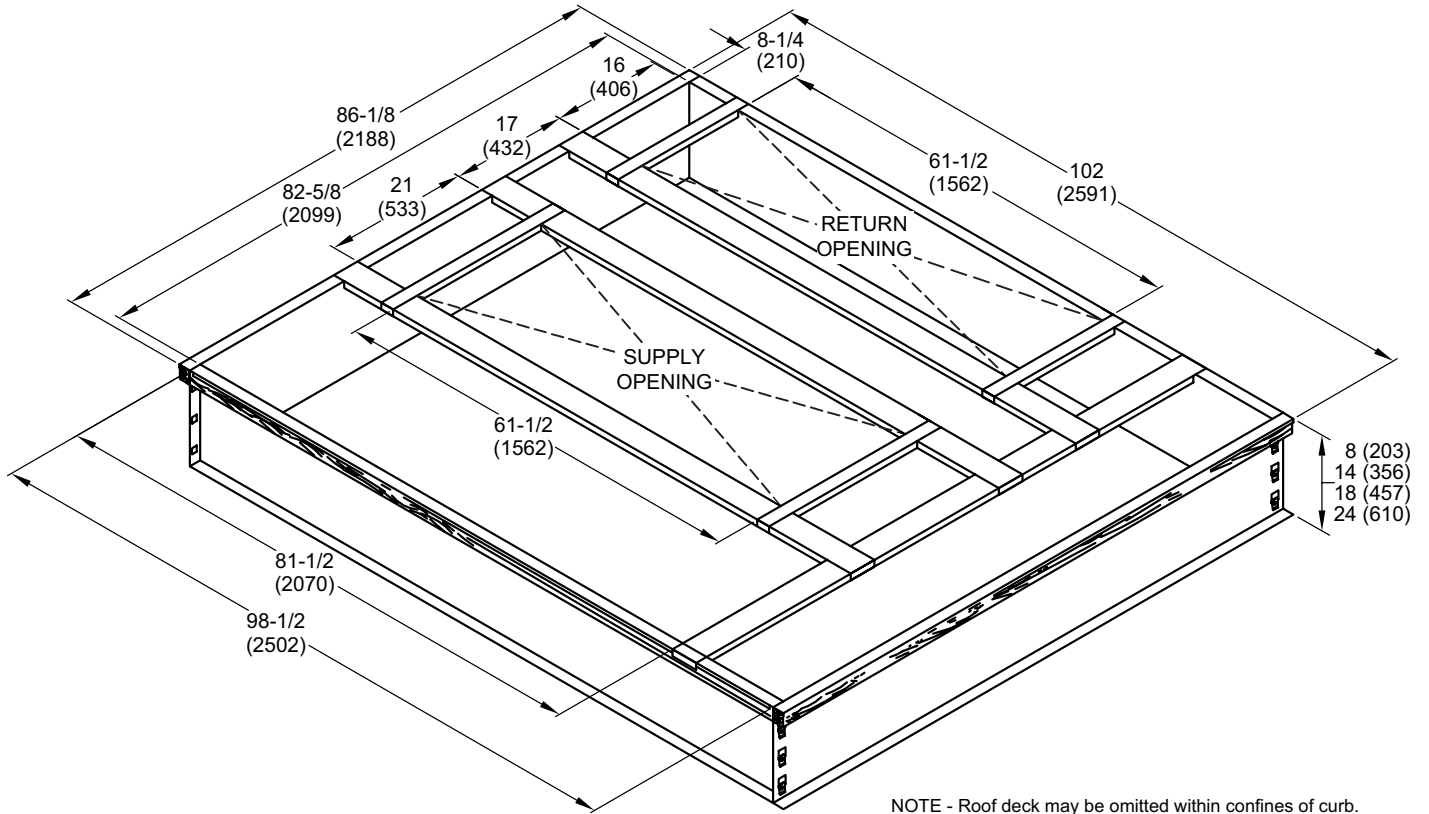

TYPICAL FLASHING DETAIL FOR ROOF CURB

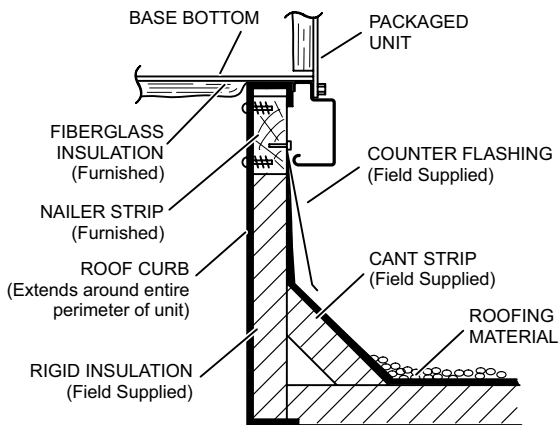

DETAIL ROOF CURB

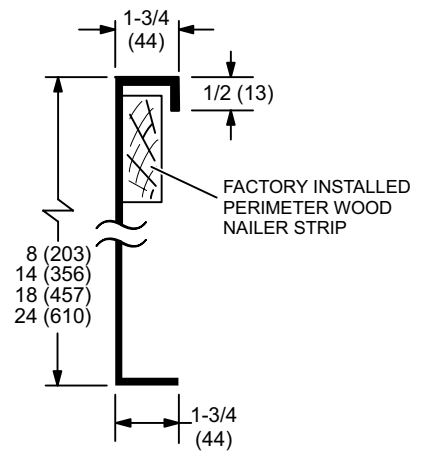

DIMENSIONS - ACCESSORIES

ADJUSTABLE PITCH CURB - DOUBLE DUCT OPENING

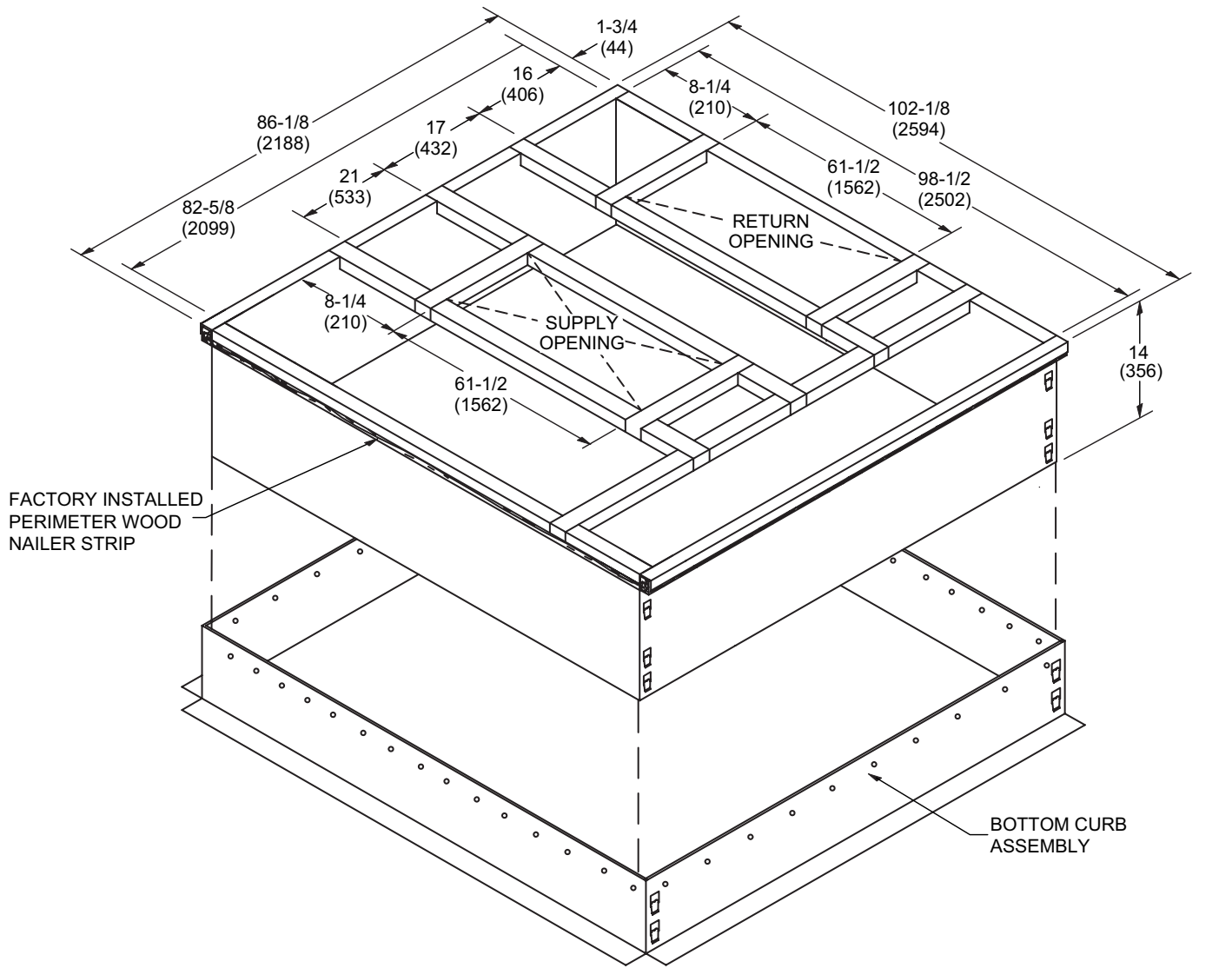

NOTE - Maximum slope pitch is 3/4 in. per 1 foot (19 mm per 305 mm) in any one direction.

TYPICAL FLASHING DETAIL FOR ROOF CURB

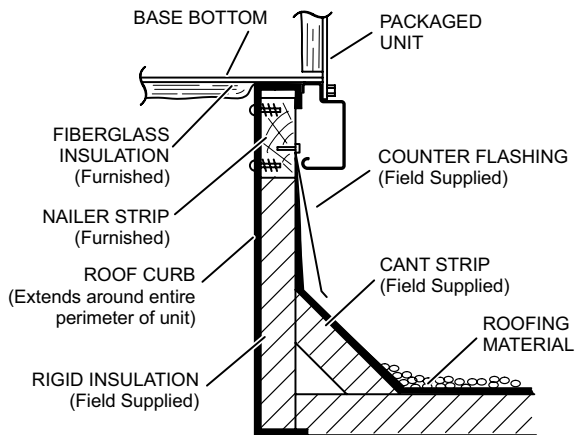

DETAIL ROOF CURB

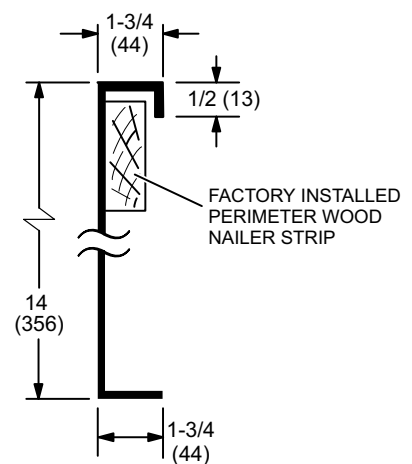

DIMENSIONS - ACCESSORIES

ROOF CURBS WITH SUPPLY & RETURN AIR TRANSITIONS FOR CEILING DIFFUSERS

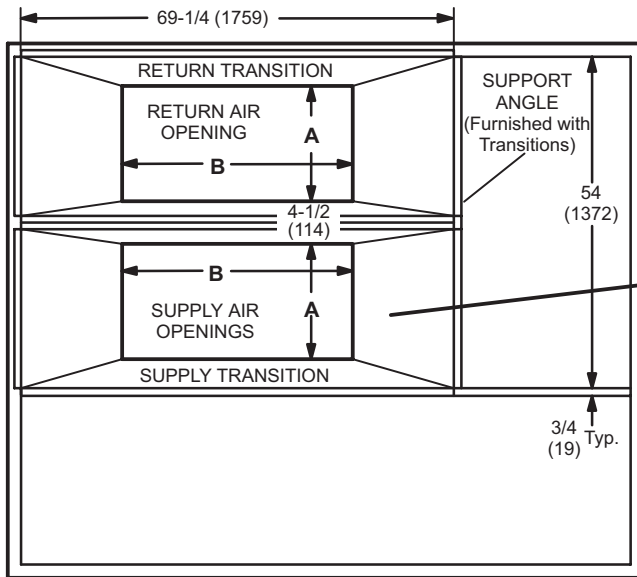

TOP VIEW

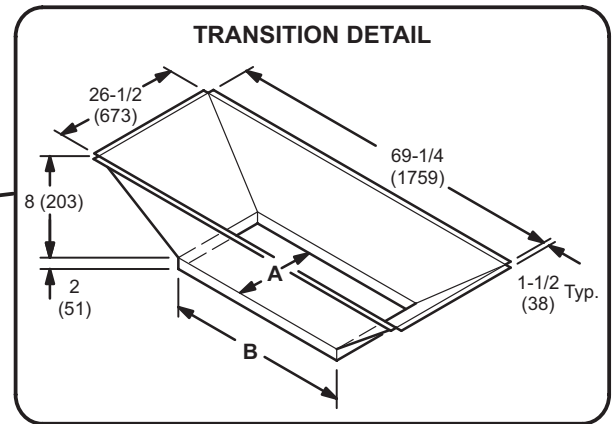

TRANSITION OPENING SIZES

Model Number	A		B	
	inch	mm	inch	mm
C1DIFF33C-1	18	457	36	914
C1DIFF34C-1	24	610	48	1219

DIMENSIONS - ACCESSORIES

HORIZONTAL ROOF CURBS – Requires Optional Horizontal Return Air Panel Kit

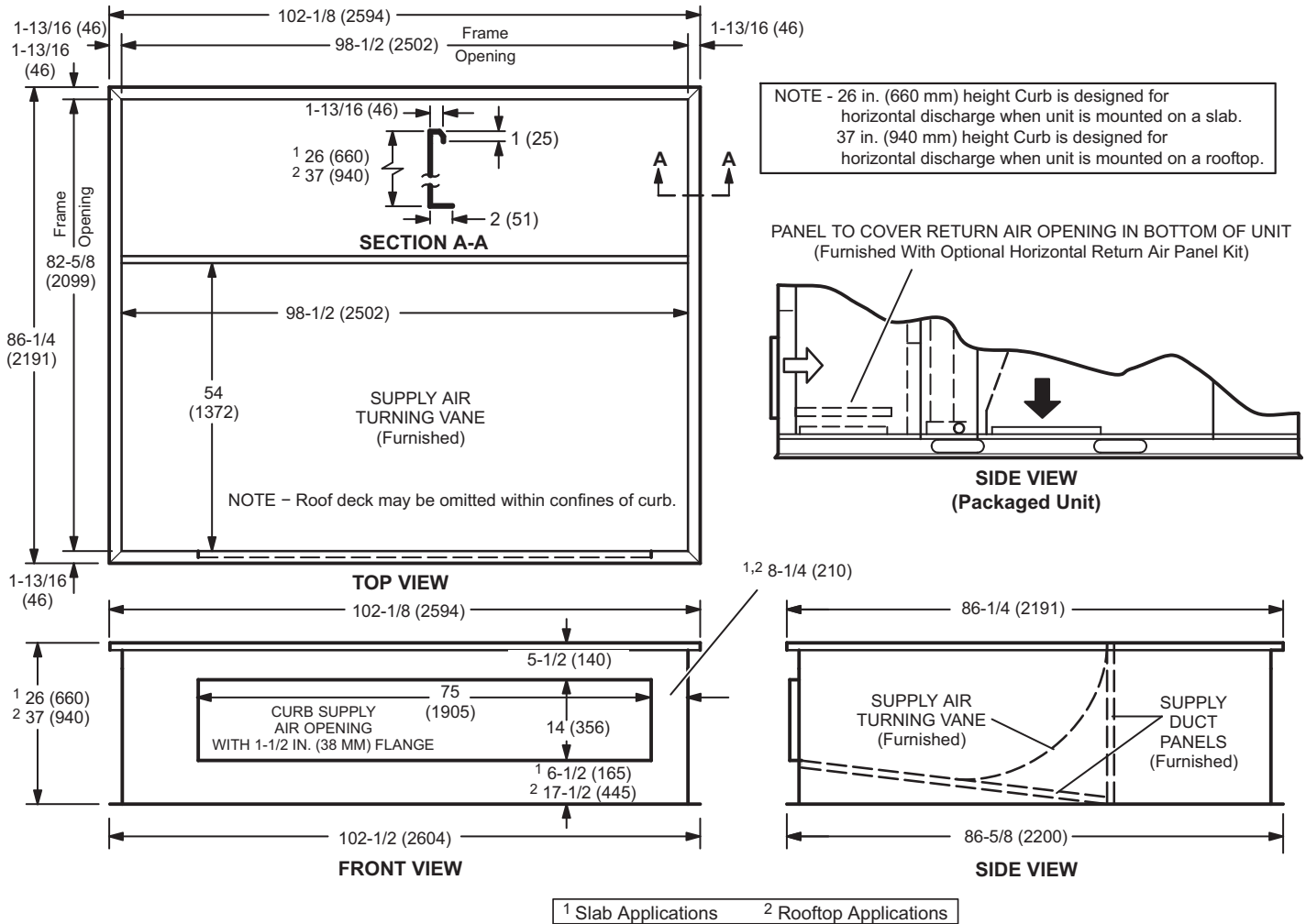

HORIZONTAL SUPPLY AND RETURN AIR OPENINGS WITH HORIZONTAL ROOF CURB

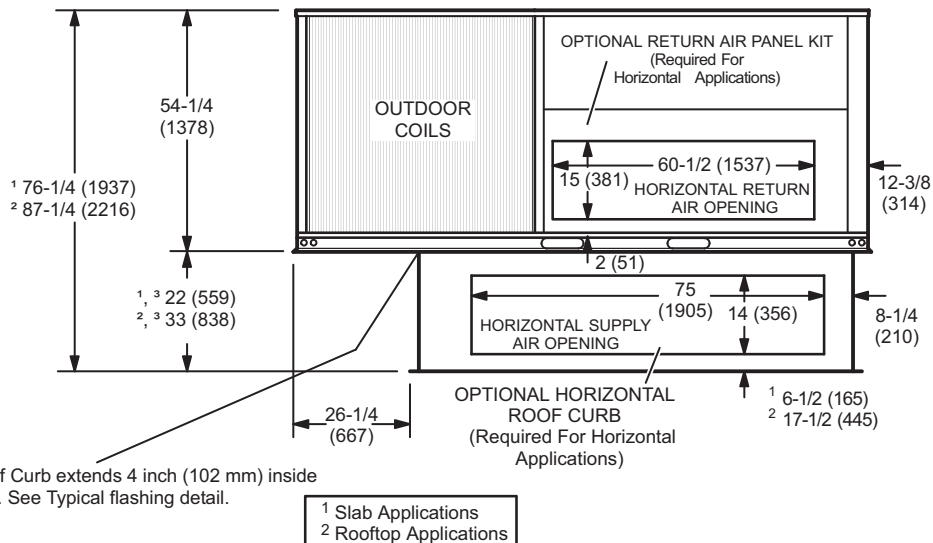

DIMENSIONS - ACCESSORIES

COMBINATION CEILING SUPPLY AND RETURN DIFFUSERS

STEP-DOWN CEILING DIFFUSER

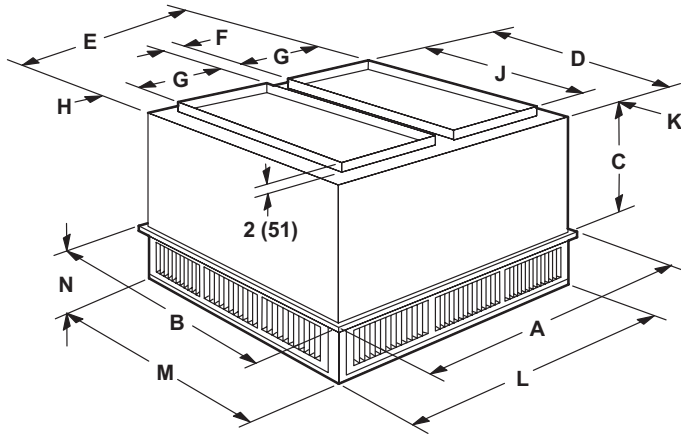

FLUSH CEILING DIFFUSER

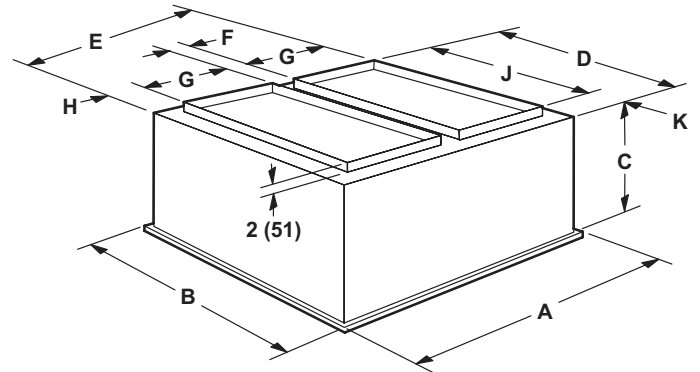

Model Number		RTD11-185S	RTD11-275
A	in.	47-5/8	59-5/8
	mm	1210	1514
B	in.	47-5/8	59-5/8
	mm	1210	1514
C	in.	24-5/8	30-5/8
	mm	625	778
D	in.	45-1/2	57-1/2
	mm	1156	1461
E	in.	45-1/2	57-1/2
	mm	1156	1461
F	in.	4-1/2	4-1/2
	mm	114	114
G	in.	18	24
	mm	457	610
H	in.	2-1/2	2-1/2
	mm	64	64
J	in.	36	48
	mm	914	1219
K	in.	4-3/4	4-3/4
	mm	121	121
L	in.	45-1/2	57-1/2
	mm	1156	1461
M	in.	45-1/2	57-1/2
	mm	1156	1461
N	in.	10-1/8	11-1/8
	mm	257	283
Duct Size	in.	18 x 36	24 x 48
	mm	457 x 914	610 x 1219

Model Number		FD11-185S	FD11-275
A	in.	47-5/8	59-5/8
	mm	1210	1514
B	in.	47-5/8	59-5/8
	mm	1210	1514
C	in.	29-1/4	35-1/4
	mm	743	895
D	in.	45	57
	mm	1143	1148
E	in.	45	57
	mm	1143	1448
F	in.	4-1/2	4-1/2
	mm	114	114
G	in.	18	24
	mm	457	610
H	in.	2-1/4	2-1/4
	mm	57	57
J	in.	36	48
	mm	914	1219
K	in.	4-1/2	4-1/2
	mm	114	114
Duct Size	in.	18 x 36	24 x 48
	mm	457 x 914	610 x 1219

REVISIONS

Sections	Description of Change
Options/Accessories	Added step-down transformers for UVC lights. Catalog numbers revised for: Condensate Drain Trap Single Enthalpy



Visit us at www.Lennox.com

For the latest technical information, www.LennoxCommercial.com

Contact us at 1-800-4-LENNOX

NOTE - Due to Lennox' ongoing commitment to quality, Specifications, Ratings and Dimensions subject to change without notice and without incurring liability. Improper installation, adjustment, alteration, service or maintenance can cause property damage or personal injury. Installation and service must be performed by a qualified installer and servicing agency.

©2021 Lennox Industries, Inc.