



**COMMERCIAL
PRODUCT SPECIFICATIONS**

Bulletin No. 210779
March 2021
Supersedes June 2020



LANDMARK®
Performance Marked by Flexibility™



**ASHRAE 90.1
COMPLIANT**

2 to 6 Tons
Net Cooling Capacity - 23,000 to 68,000 Btuh
Net Heating Capacity - 25,000 to 70,000 Btuh
Optional Electric Heat - 5 to 30 kW

MODEL NUMBER IDENTIFICATION

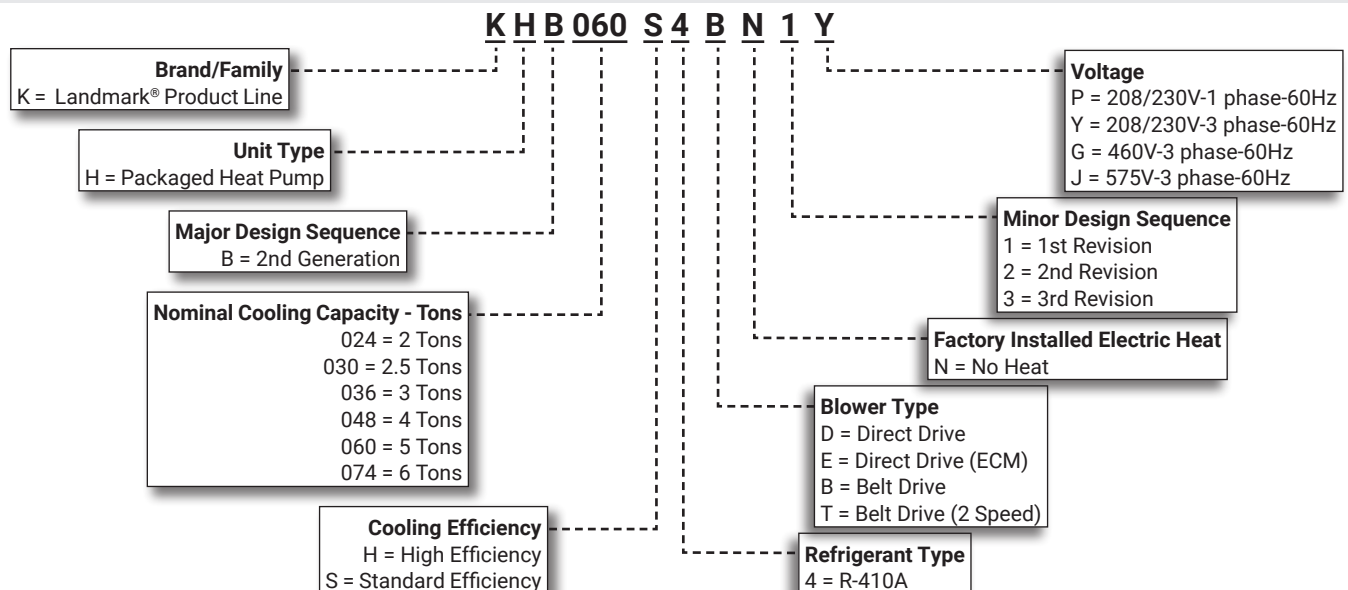

FEATURE HIGHLIGHTS

Landmark® rooftop units from Lennox® are the new standard for reliable, efficient rooftop units built for long-lasting performance that can significantly improve indoor environments.

1. Scroll Compressor
2. Check/Thermal Expansion Valve
3. Reversing Valve
4. Copper Tube Outdoor Coil
5. Outdoor Coil Fan Motor
6. Heavy Gauge Steel Cabinet
7. Power Entry
8. Insulation
9. Hinged Access Panels (option)
10. Supply Air Blower
11. Unit Control
12. Air Filters
13. Electric Heat (option)
14. Economizer (option)
15. Power Exhaust Fans (option)

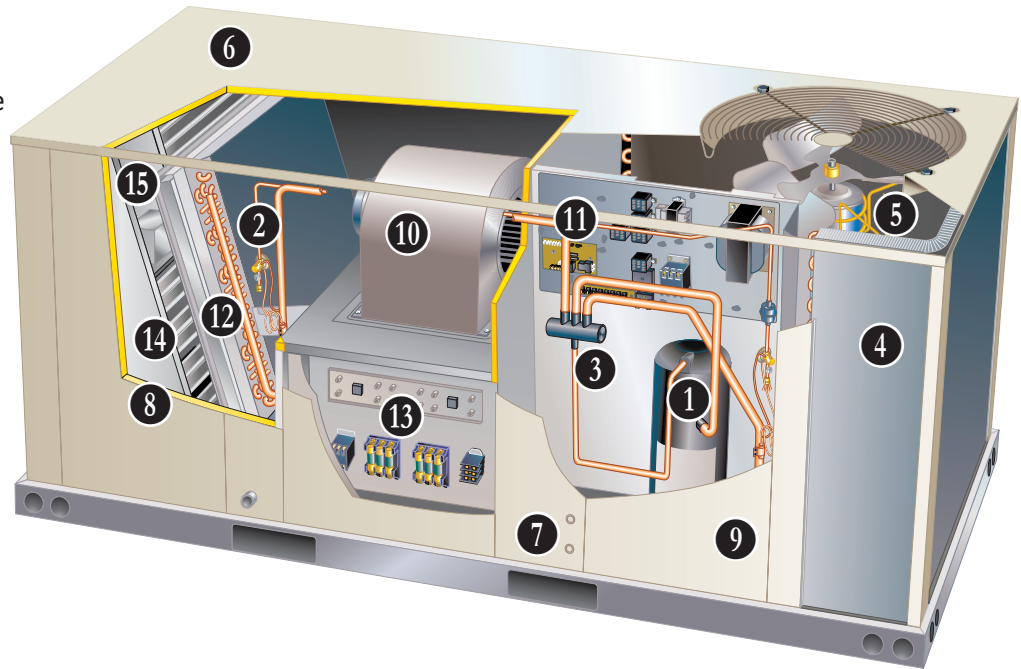

CONTENTS

Approvals And Warranty	3
Blower Data	25
Cooling / Heating Ratings	18
Dimensions - Accessories	58
Dimensions - Unit	57
Electrical/Electric Heat Data	42
Electric Heat Capacities	55
Features And Benefits	3
Model Number Identification.	1
Optional Conventional Temperature Control Systems	9
Options / Accessories	10
Outdoor Sound Data	41
Specifications	14
Unit Clearances	55
Weight Data	56

APPROVALS AND WARRANTY

APPROVALS

- AHRI Standard 210/240 certified (2 - 5 ton models)
- AHRI Standard 340/360 certified (6 ton models)
- ETL and CSA listed
- CSA certified energy ratings
- Unit and components ETL, NEC and CEC bonded for grounding to meet safety standards for servicing
- All models are ASHRAE 90.1 compliant
- ISO 9001 Registered Manufacturing Quality System

WARRANTY

- Compressors - Limited five years
- Optional High Performance Economizers - Limited five years
- All other covered components - Limited one year

FEATURES AND BENEFITS

COOLING / HEATING SYSTEM

- Designed to maximize sensible and latent cooling performance at design conditions
- System can operate from 30°F to 125°F without any additional controls

R-410A Refrigerant

- Non-chlorine based
- Ozone-friendly

1 Single Speed Scroll Compressor (024 through 060 Standard Efficiency Models)

- Scroll compressors for high performance, reliability and quiet operation
- Resiliently mounted on rubber grommets for quiet operation

Two-Stage Scroll Compressor (All High Efficiency Models and 074 Standard Efficiency Models)

- Two-stage scroll compressors for increased part load efficiency, high performance, reliability and quiet operation
- Resiliently mounted on rubber grommets for quiet operation

Compressor Crankcase Heater

- Protects against refrigerant migration that can occur during low ambient operation

High Pressure Switch

- Protects the system from high pressure conditions

2 Check/Thermal Expansion Valves

- Assures optimal performance throughout the application range.
- Removable element head

3 Reversing Valve

- 4-way interchange reversing valve effects a rapid change in direction of refrigerant flow resulting in quick changeover from cooling to heating and vice versa

Defrost Control

- Control furnished as standard
- Gives a demand defrost cycle whenever system heating performance falls below optimum levels
- Sensing element on coil determines when defrost cycle is required and when to terminate cycle
- Anti-short cycle (5 minutes) incorporated into the board
- Diagnostic LED's furnished as an aid in troubleshooting

Filter/Drier

- High capacity filter/drier protects the system from dirt and moisture

Freezestat

- Protects the evaporator coil from damaging ice build-up due to conditions such as low/no air flow, or low refrigerant charge

4 Coil Construction

- Copper tube construction
- Enhanced rippled-edge aluminum fins
- Flared shoulder tubing connections
- Silver soldered construction
- Factory leak tested

Indoor Coil

- Cross row circuiting
- Rifled copper tubing optimizes both sensible and latent cooling capacity

Condensate Drain Pan

- Plastic pan, sloped to meet drainage requirements of ASHRAE 62.1
- Side or bottom drain connections
- Reversible to allow connection at back of unit

FEATURES AND BENEFITS

COOLING / HEATING SYSTEM (continued)

5 Outdoor Coil Fan Motor

- High efficiency models have a variable speed (ECM) fan motor for energy efficient and quiet operation
- Standard efficiency models have a single speed PSC fan motor
- Thermal overload protected
- Totally enclosed
- Permanently lubricated sleeve bearing (standard efficiency)
- Permanently lubricated ball bearings (high efficiency)
- Shaft up
- Wire basket mount

Outdoor Coil Fan

- PVC coated fan guard furnished.

Required Selections

Cooling Capacity

- Specify nominal cooling capacity

Options/Accessories

Field Installed

Condensate Drain Trap

- Available in copper or PVC

Drain Pan Overflow Switch

- Monitors condensate level in drain pan, shuts down unit if drain becomes clogged

Low Ambient Kit (0°F)

- Cycles the outdoor fan while allowing compressor operation in the cooling cycle
- Includes field installed pressure switch on the liquid line to determine when to operate the outdoor fan
- This intermittent fan operation allows the system to operate without icing the evaporator coil and losing capacity
- Designed for use in ambient temperatures no lower than 0°F
- **Standard Efficiency Models** - If liquid line pressure drops below 240 psig outdoor fan stops until main pressure switch has reset to 450 psig to resume normal cooling operation
- **High Efficiency Models** - If the liquid line pressure drops below 240 psig outdoor fan operates at 25% normal fan speed
- If pressure drops below 180 psig outdoor fan stops until pressure rises to 300 psig, then fan operates at 25% normal fan speed unless main pressure switch has reset to 450 psig to resume normal cooling operation and full fan speed operation

CABINET

6 Construction

- Heavy-gauge steel panels
- Two-layer enamel paint finish
- Full perimeter heavy-gauge galvanized steel base rail
- Base rails have rigging holes
- Three sides of the base rail have fork slots
- Raised edges around duct and power entry openings in the bottom of the unit for water protection

Airflow Choice

- Units are shipped in downflow (vertical) configuration
- Can be field converted to horizontal air flow configuration without the need of a kit

7 Power Entry

- Electrical lines can be brought through the unit base or through horizontal access knock-outs

8 Insulation

- Fully insulated with non-hygroscopic fiberglass insulation (conditioned areas)
- Unit base is fully insulated
- Base insulation serves as an air seal to the roof curb, eliminating the need to add a seal during installation

Access Panels

- Economizer/Filter section
- Heating/Blower section
- Compressor/Controls section

NOTE - All 048/060/074 models include a filler panel for proper cabinet fit for optional accessories (Economizers, Power Exhaust, Outdoor Air Dampers and Barometric Relief Dampers).

Options/Accessories

Factory Installed

Corrosion Protection

- Completely flexible immersed coating
- Electrodeposited dry film process
- AST ElectroFin E-Coat
- Meets Mil Spec MIL-P-53084, ASTM B117 Standard Method Salt Spray Testing
- Indoor Corrosion Protection:
 - Coated coil
 - Painted blower housing
 - Painted base
- Outdoor Corrosion Protection:
 - Coated coil
 - Painted outdoor base

9 Hinged Access Panels

- Economizer/Filter section
- Heating/Blower section
- Compressor/Controls section
- Panel seals and quarter-turn latching handles provide a tight air and water seal

FEATURES AND BENEFITS

CABINET (continued)

Field Installed

Combination Coil/Hail Guards

- Heavy gauge steel frame
- Painted to match cabinet
- Expanded metal mesh protects outdoor coil

BLOWER

- A wide selection of supply air blower options are available to meet a variety of air flow requirements

10 Motor

- Overload protected
- Ball bearings (belt drive)
- Sleeve bearings (direct drive)
- Direct Drive motors are available on 024, 030, 036 and 048 standard efficiency models
- Variable-Speed ECM direct drive motors are available on 024, 036, 048 and 060 high efficiency models
- Single Speed belt drive motors are available on 036, 048 and 060 standard efficiency models in several different sizes to maximize air performance
- Two-Speed belt drive motors (low static/high static) are available on 036, 048 and 060 high efficiency models and 074 standard efficiency model in several different sizes to maximize air performance.

Supply Air Blower

- Forward curved blades
- Blower wheel is statically and dynamically balanced
- Belt drive motors have adjustable pulley for speed change

Required Selections

- Order direct drive or belt drive blower. (See Blower Data Table for specifications)
- Belt Drive - Order drive kit, see Drive Kit Specifications Table

CONTROLS

11 Unit Control

- All control voltage is provided via a 24V (secondary) transformer with built-in circuit breaker protection
- Up to 2 heat / 2 cool staging with a third party DDC control system or thermostat
- Low voltage terminal block provides screw terminal connections for thermostat or controller wiring
- Night Setback Mode saves energy by closing outdoor air dampers and operating supply fan on thermostat demand only

Options/Accessories

Field Installed

L Connection® Network

- Complete building automation control system for single or multi-zone applications
- Options include local interface, software for local or remote communication, and hardware for networking other control functions

- See L Connection Network Product Specifications Bulletin for details

Smoke Detector

- Photoelectric type
- Installed in supply air section, return air section or both sections
- Available with power board and single sensor (supply or return) or power board and two sensors (supply and return)
- Power board located in unit control compartment

Thermostats

- Control system and thermostat options, see page 9

INDOOR AIR QUALITY

12 Air Filters

- Disposable 2 inch filters furnished as standard

Options/Accessories

Field Installed

Healthy Climate® High Efficiency Air Filters

- Disposable MERV 8 or MERV 13 (Minimum Efficiency Reporting Value based on ASHRAE 52.2) efficiency 2 inch pleated filters

Healthy Climate® UVC Germicidal Lamps

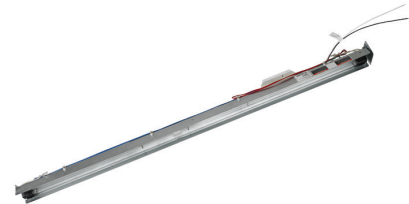

- Germicidal lamps emit ultra-violet (UV-C) energy, which has been proven to be effective in reducing microbes such as viruses, bacteria, yeasts, and molds
 - This process either destroys the organism or controls its ability to reproduce
 - UV-C energy greatly reduces the growth and proliferation of mold and other bioaerosols (bacteria and viruses) on illuminated surfaces (particularly coil and drain pan)
 - Field installed in the blower/evaporator coil section
 - Magnetic safety interlock terminates power when access panels are removed
 - All necessary hardware for installation is included
 - Lamps operate on 110/230V-1ph power supply
- NOTE** - Step-down transformer may be ordered separately for 460V and 575V units.
- Approved by ETL

FEATURE AND BENEFITS

INDOOR AIR QUALITY (continued)

Options/Accessories (continued)

Field Installed

Indoor Air Quality (CO₂) Sensors

- Monitors CO₂ levels
- Reports to the Unit Controller which adjusts economizer dampers as needed

ELECTRICAL

Marked & Color-Coded Wiring

- All electrical wiring is color-coded and marked to identify which components it is connecting

Electrical Plugs

- Positive connection electrical plugs are used to connect common accessories or maintenance parts for easy removal or installation

Required Selections

Voltage Choice

- Specify when ordering base unit

Options/Accessories

Factory or Field Installed

Disconnect Switch up to 150 Amp

- Accessible from outside of unit
- Spring loaded weatherproof cover furnished

GFI Service Outlets (2)

- 115V ground fault circuit interrupter (GFCI) type
- Non-powered
- Field-wired

Field Installed

13 Electric Heat

- Helix wound nichrome elements
- Individual element limit controls
- Wiring harness
- Unit fuse block
- See Options / Accessories tables for ordering information

GFI Weatherproof Cover

- Single-gang cover
- Heavy-duty UV-resistant polycarbonate case construction
- Hinged base cover with gasket

OPTIONS/ACCESSORIES

ECONOMIZER

Factory or Field Installed

14 Economizer (Standard and High Performance Common Features)

- Combination Outdoor Air Hood is furnished
- Factory installed Economizer can be ordered with two exhaust options:
 - Barometric Relief Dampers
 - No Exhaust
- Field installed Economizer includes Barometric Relief Dampers with Combination Hood
- Barometric Relief Dampers allow relief of excess air, dampers prevent blow back and outdoor air infiltration during off cycle, bird screen furnished

NOTE - Barometric Relief Dampers are required when Economizer is factory installed with field installed Power Exhaust Fan option. See Power Exhaust Fan section and Options/Accessories table.

- Occupied/Unoccupied mode with field furnished setback thermostat
- Demand Control Ventilation (DCV) ready using optional CO₂ sensors
- Mixed Air Sensor is furnished for field installation in the rooftop unit

NOTE - Sensor is factory installed when Economizers are factory installed.

- Single sensible sensor is furnished with Economizer and enables economizer operation if the outdoor temperature is less than the setpoint of the control
- Horizontal Barometric Dampers are required for horizontal Economizer applications and must be ordered separately

Standard Economizer Features (Not for Title 24)

- Gear-driven action
- Return air and outdoor air dampers
- Plug-in connections to unit
- Neoprene seals
- 24-volt, fully-modulating spring return motor

ECONOMIZER (continued)

Standard Economizer Control Module

- Standard Economizer Control Module can be adjusted to operate based on outdoor air temperatures

Economizer Controls:

- **Damper Minimum Position** - Can be set lower than traditional minimum air requirements resulting in cost savings
- **IAQ Sensor** - Signals dampers to modulate and maintain 55°F when CO₂ is higher than the CO₂ setpoint
- **Demand Control Ventilation (DCV) LED** - A steady green Demand Control Ventilation LED indicates the IAQ reading is higher than setpoint and requires more fresh air
- **Free Cool LED** - A steady green LED indicates outdoor air is suitable for free cooling
 - Free Cooling runs when outdoor air temperature is lower than the set temperature on the economizer control

NOTE: The Free Cooling default setting for outdoor air temperature sensor is 55°F.

High Performance Economizer Features

- Approved for California Title 24 building standards
- Low leakage dampers are Air Movement and Control Association International (AMCA) Class 1A Certified - Maximum 3 cfm per sq. ft. leakage at 1 in. w.g.
- ASHRAE 90.1 compliant
- Gear-driven action
- High torque 24-volt fully-modulating spring return damper motor
- Return air and outdoor air dampers
- Plug-in connections to unit
- Nylon bearings
- Enhanced thermoplastic vulcanizate (TPV) seals
- Flexible stainless steel jamb seals

NOTE - High Performance Economizers are not approved for use with enthalpy controls in Title 24 applications.



High Performance Economizer Control Module

- Module provides inputs and outputs to control economizer based on parameter settings
- Module automatically detects sensors by polling to determine which sensors are installed in system
- Module displays any alarm messages (fault detection and diagnostics) as an aid in troubleshooting
- Non-volatile memory retains parameter settings in case of power failure
- Keypad with four navigation buttons and LCD screen is furnished for setting economizer parameters:
 - Menu Up/Exit (⬆) button returns to the main menu
 - Arrow Up (▲) button moves to the previous or next parameter within the selected menu
 - Arrow Down (▼) button moves to the next parameter within the selected menu
 - Select (enter) (↵) button confirms parameter selection



Main Menu Structure:

- **Status** (economizer and system operation status)
- **Setpoints** (settings for various setpoint parameters)
- **System Setup** (settings/information about the system)
- **Advanced Setup** (freeze protection, CO₂ settings, stage 3 delay and additional calibration settings)
- **Checkout** (damper positions)
- **Alarms** (output signal that can be configured for remote alarm monitoring)

NOTE - The Free Cooling setpoint for Title 24 applications must be set based on the Climate Zone where the system is installed. See Section 140.4 "Prescriptive Requirements for Space Conditioning Systems" of the California Energy Commission's 2013 Building Energy Efficiency Standards.

NOTE - Refer to Installation Instructions for complete setup information and menu parameters available.

Factory or Field Installed

Single Enthalpy Temperature Control (Not for Title 24)

- Outdoor air enthalpy sensor enables Economizer if the outdoor enthalpy is less than the setpoint of the control

Field Installed

Differential Enthalpy Control (Not for Title 24)

- Order two Single Enthalpy Controls
- One is field installed in the return air section, the other in the outdoor air section
- Allows the economizer control board to select between outdoor air or return air, whichever has lower enthalpy

OPTIONS/ACCESSORIES

EXHAUST

Field Installed

Horizontal Barometric Relief Dampers

- For use when unit is configured for horizontal applications with an economizer
- Allows relief of excess air
- Blade type dampers prevent blow back and outdoor air infiltration during off cycle
- Field installed in return air duct
- Exhaust hood with bird screen furnished

NOTE - Requires Horizontal Economizer Conversion Kit.

Horizontal Economizer Conversion Kit

- Insulated panel covers the bottom return air opening on the unit base to convert downflow Economizer to horizontal airflow

15 Power Exhaust Fan

- Installs internal to unit for downflow applications only with Economizer option
- Provides exhaust air pressure relief
- Interlocked to run when supply air blower is operating, fan runs when outdoor air dampers are 50% open (adjustable)
- Motor is overload protected.
- 16 in. diameter fan
- 4 fan blades
- 1/3 hp motor

NOTE - Not available for 024 and 030 models.

NOTE - If Power Exhaust is field installed with a factory installed Economizer, the Economizer must be ordered with No Exhaust option. Barometric Relief Dampers must also be ordered separately for field installation.

OUTDOOR AIR

Factory or Field Installed

Outdoor Air Dampers - Downflow or Horizontal With Air Hood

- Single blade damper
- 0 to 25% (fixed) outdoor air adjustable
- Installs in unit
- Includes outdoor air hood
- Automatic model features fully modulating spring return damper motor with plug-in connection
- Manual model features a slide damper
- Maximum mixed air temperature in cooling mode: 100°F

ROOF CURBS

Field Installed

- Nailer strip furnished
- Mates to unit
- US National Roofing Contractors Approved
- Shipped knocked down

Hybrid Roof Curbs

- Downflow
- Interlocking tabs fasten corners together
- No tools required
- Can also be fastened together with furnished hardware
- Available in 8, 14, 18, and 24 inch heights

Full Perimeter Curbs, Downflow (090 Models Only)

- Hybrid roof curbs can be assembled using interlocking tabs to fasten corners together
- No tools required.
- Can also be fastened together with furnished hardware
- Available in 8, 14, 18, and 24 inch heights

NOTE - 060H and 074 models can be used on smaller 79-3/4 in. Hybrid Roof Curbs (not full perimeter) with 15-3/4 in. overhang at condenser end of unit. See dimension drawing on page 62.

Adjustable Pitch Curb

- Downflow
- Fully adjustable pitch curbs (3/4 in. per foot in any direction) provide a level platform for rooftop units allowing flexible installations on roofs with uneven or sloped angles
- Uses interlocking tabs to fasten corners together. No tools required
- Hardware is furnished to connect upper curb with lower curb
- Available in 14 inch height

Adaptor Curbs (not shown)

- Curbs are regionally sourced
- Dimensions vary based upon the source

NOTE - Contact your local sales representative for a detailed cut sheet with applicable dimensions.

CEILING DIFFUSERS

Field Installed

Ceiling Diffusers (Flush or Step-Down)

- White powder coat finish on diffuser face and grilles
- Insulated UL listed duct liner
- Diffuser box has collars for duct connection
- Step-down diffusers have double deflection blades
- Flush diffusers have fixed blades
- Provisions for suspending
- Internally sealed to prevent recirculation
- Removable return air grille
- Adapts to T-bar ceiling grids or plaster ceilings

Transitions (Supply and Return)

- Used with diffusers
- Installs in roof curb
- Galvanized steel construction
- Flanges furnished for duct connection to diffusers
- Fully insulated

OPTIONAL CONVENTIONAL TEMPERATURE CONTROL SYSTEMS

ComfortSense® 7500 Commercial 7-Day Programmable Thermostat



- Four-Stage Heating / Two-Stage Cooling
- Universal Multi-Stage
- Intuitive Touchscreen Interface
- Automatic Changeover between Heating and Cooling
- Full Seven-Day Programming
- Four Time Periods Per Day
- Temperature and Humidity Control
- One-Touch Away Mode
- Holiday Scheduling
- Smooth Setback Recovery (SSR)
- Performance Reports
- Notifications/Reminders
- Dehumidification/Humiditrol® Control for Split Systems and Rooftop Units
- Economizer Relay Control
- Backlit Display
- Wallplate Furnished
- FDD, ASHRAE and IECC Compliant

ComfortSense® 3000 Commercial 5-2 Day Programmable Thermostat

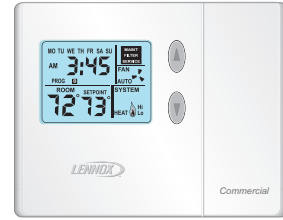

- Two-Stage Heating / Two-Stage Cooling
- Conventional Systems
- Intuitive Interface
- 5-2 Day Programming
- Program Hold
- Remote Indoor Temperature Sensing
- Smooth Setback Recovery (SSR)
- Economizer Relay Control
- Maintenance/Filter/Service Reminders
- Backlit Display
- Wallplate Furnished
- Simple Up and Down Temperature Control

Bacnet Compatible Thermostat With Reheat Function



- 7-Day Programmable
- For units with or without Humiditrol®
- BTL listed MS/TP ensures compatibility with any BACnet system
- Built-in control programs for conventional and heat pump applications
- Conventional systems up to 3-stage heat and 3-stage cool
- Heat pumps with 1 or 2 compressors and up to 2-stage auxiliary heat
- On-board temperature and humidity sensor
- Multiple configurable inputs and outputs enable advanced control strategies
- Set-up Wizard enables rapid system configuration
- No special tools required for installation or commissioning
- Seven-day (2, 4 or 6 event) occupancy scheduling per day
- Backlit 5-inch LCD touchscreen

Description

ComfortSense® 7500 Commercial 7-Day Programmable Thermostat

Description		Catalog No.
CS7500 7-Day Thermostat		17G74
Sensors/	1 Remote non-adjustable wall-mount 20k	47W36
Accessories	1 Remote non-adjustable wall-mount 10k	47W37
	Remote non-adjustable discharge air (duct mount)	19L22
	Outdoor temperature sensor	X2658

ComfortSense® 3000 5-2 Day Programmable

CS3000 5-2 Day Thermostat		11Y05
Sensor/	Remote non-adjustable wall mount 10k averaging	47W37
Accessories	Thermostat wall mounting plate	X2659
BACnet	2 7-Day BACnet Thermostat	Y8241
Controls	3 BACnet Module (factory or field)	16X70
4 BACnet	With Display	97W23
Room Sensors	Without Display	97W24

Universal Thermostat Guard with Lock (clear)

Inside Dimensions (H x W) 5 7/8 x 8 3/8 in.	39P21
---	--------------

¹ Remote wall-mount sensors can be applied in any of the following combinations:
One Sensor - (1) 47W36, Two Sensors - (2) 47W37, Three Sensors - (2) 47W36 and (1) 47W37
Four Sensors - (4) 47W36, Five Sensors - (3) 47W36 and (2) 47W37

² BACnet Thermostat (Y8241) will control units with and without the Humiditrol® option. If there is a mix of units equipped with and without Humiditrol on the same site, this thermostat can be used for all units if suitable.

³ Not compatible with units equipped with Humiditrol® option.

⁴ Only compatible with BACnet Module (16X70).

OPTIONS / ACCESSORIES

Item	Catalog No.	Unit Model No.						
		KHB 024	KHB 030	KHB 036	KHB 048	KHB 060	KHB 074	
COOLING SYSTEM								
Condensate Drain Trap	PVC	22H54	X	X	X	X	X	X
	Copper	76W27	X	X	X	X	X	X
Drain Pan Overflow Switch		74W42	X	X	X	X	X	X
Low Ambient Kit	Standard Efficiency	14D96	X	X	X	X	X	X
	High Efficiency	15C84	X		X	X	X	
Efficiency	Standard		O	O	O	O	O	O
	High		O		O	O	O	
Refrigerant Type		R-410A	O	O	O	O	O	O

BLOWER - SUPPLY AIR

Motors	Direct Drive - 0.25 hp (208/230V-1ph)	Factory	¹ O	¹ O					
	Direct Drive - 0.33 hp (208/230V-1ph)	Factory	² O		² O				
	Direct Drive - 0.50 hp (208/230V-1ph, 208/230V-3ph, 460V-3ph, 575V-3ph)	Factory			^{1,2} O	¹ O			
	Direct Drive - 0.75 hp (208/230V-1ph, 208/230V-3ph, 460V-3ph, 575V-3ph)	Factory				² O			
	Direct Drive - 1.0 hp (208/230V-1ph, 208/230V-3ph, 460V-3ph, 575V-3ph)	Factory					² O		
	Belt Drive - 0.75 hp (208/230V-1ph)	Factory			O	O	O		
	Belt Drive - 1.5 hp (208/230V-1ph)	Factory			O	O	O		
	Belt Drive - 1 hp (208/230V, 460V, 575V-3ph)	Factory			O	O	O		
	Belt Drive - 2 hp (208/230V, 460V, 575V-3ph)	Factory			O	O	O		
	Belt Drive - 0.75 hp (208/230V, 460V, 575V-3ph) (2 Speed)	Factory			O	O			
	Belt Drive - 1 hp (208/230V, 460V, 575V-3ph) (2 Speed)	Factory			O		O	O	
	Belt Drive - 2 hp (208/230V, 460V, 575V-3ph) (2 Speed)	Factory				O	O	O	
	Drive Kits See Blower Data Tables for selection	Kit A01 - 673-1010 rpm	Factory			O			
		Kit A02 - 745-1117 rpm	Factory				O		
Kit A03 - 833-1250 rpm		Factory					O		
Kit A04 - 968-1340 rpm		Factory						O	
Kit A05 - 897-1346 rpm		Factory			O				
Kit A06 - 1071-1429 rpm		Factory				O			
Kit A07 - 1212-1548 rpm		Factory					O		
Kit A08 - 1193-1591 rpm		Factory						O	

CABINET

Combination Coil/Hail Guards	13R98	X	X	X			
	13T03				X	³ X	
	13T17					⁴ X	X
Corrosion Protection		O	O	O	O	O	O
Hinged Access Panels		O	O	O	O	O	O

CONTROLS

NOTE - Also see Conventional Thermostat Control Systems on page 9 for Additional Options.

Smoke Detector - Supply or Return (Power board and one sensor)	21Z11	X	X	X	X	X	X
Smoke Detector - Supply and Return (Power board and two sensors)	21Z12	X	X	X	X	X	X

¹ Standard Efficiency Models.

² High Efficiency Models.

³ Standard Efficiency 060S models only.

⁴ High Efficiency 060H models only.

NOTE - The catalog and model numbers that appear here are for ordering field installed accessories only.

OX - Field Installed or Configure to Order (factory installed)

O - Configure to Order (Factory Installed)

X - Field Installed

OPTIONS / ACCESSORIES

Item	Catalog No.	Unit Model No.					
		KHB 024	KHB 030	KHB 036	KHB 048	KHB 060	KHB 074
ECONOMIZER							
Standard Economizer With Outdoor Air Hood (Sensible Control) (Not for Title 24)							
Standard Economizer - Includes Barometric Relief Dampers and Exhaust Hood	14D90	OX	OX	OX	OX	OX	OX
Economizer - No Exhaust	Factory	O	O	O	O	O	O
Standard Economizer Controls (Not for Title 24)							
Single Enthalpy Control	21Z09	OX	OX	OX	OX	OX	OX
Differential Enthalpy Control (order 2)	21Z09	X	X	X	X	X	X
High Performance Economizer With Outdoor Air Hood (Sensible Control) (Approved for California Title 24 Building Standards / AMCA Class 1A Certified)							
High Performance Economizer - Includes Barometric Relief Dampers and Exhaust Hood	20H49	OX	OX	OX	OX	OX	OX
High Performance Economizer - No Exhaust	Factory	O	O	O	O	O	O
High Performance Economizer Controls (Not for Title 24)							
Single Enthalpy Control	10Z75	OX	OX	OX	OX	OX	OX
Differential Enthalpy Control (order 2)	10Z75	X	X	X	X	X	X
Economizer Accessories							
Horizontal Economizer Conversion Kit	17W45	X	X	X	X	X	X
POWER EXHAUST FAN							
Standard Static	208/230V-1 or 3ph	21Z13		X	X	X	X
<i>NOTE - Field installed Power Exhaust Fan requires "Barometric Relief Dampers for Power Exhaust Kit" for field installation. See below.</i>	460V-3ph	21Z14		X	X	X	X
	575V-3ph	21Z15		X	X	X	X
BAROMETRIC RELIEF							
¹ Barometric Relief Dampers for Power Exhaust Kit		21Z21		X	X	X	X
² Horizontal Barometric Relief Dampers With Exhaust Hood		19F01	X	X	X	X	X
OUTDOOR AIR							
Outdoor Air Dampers - Includes Outdoor Air Hood							
Motorized		15D17	OX	OX	OX	OX	OX
Manual		15D18	OX	OX	OX	OX	OX
¹ Required when Economizer is factory installed with field installed Power Exhaust Fan option.							
² Required when Economizer is configured for horizontal airflow.							
NOTE - The catalog and model numbers that appear here are for ordering field installed accessories only.							
OX - Field Installed or Configure to Order (factory installed)							
O - Configure to Order (Factory Installed)							
X - Field Installed							

OPTIONS / ACCESSORIES

Item	Catalog No.	Unit Model No.					
		KHB 024	KHB 030	KHB 036	KHB 048	KHB 060	KHB 074
ELECTRICAL							
Disconnect	See Electrical/Electric Heat Tables for selection	OX	OX	OX	OX	OX	OX
Voltage 60 Hz	208/230V - 1 phase	O	O	O	O	O	
	208/230V - 3 phase			O	O	O	O
	460V - 3 phase			O	O	O	O
	575V - 3 phase			O	O	O	O
GFI Service Outlets	15 amp non-powered, field-wired (208/230V, 460V only)	74M70	OX	OX	OX	OX	OX
	20 amp non-powered, field-wired (575V only)	67E01	X	X	X	X	X
Weatherproof Cover for GFI		10C89	X	X	X	X	X
ELECTRIC HEAT							
5 kW	208/230V- 1ph	12F06	X	X			
7.5 kW	208/230V-1ph	14W32	X	X	X	X	X
	208/230V-3ph	14W35			X	X	X
	460V-3ph	14W39			X	X	X
	575V-3ph	14W43			X	X	X
10 kW	208/230V-1ph	30W26	X	X			
15 kW	208/230V-1ph	14W33			X	X	X
	208/230V-3ph	14W36			X	X	X
	460V-3ph	14W40			X	X	X
	575V-3ph	14W44			X	X	X
22.5 kW	208/230V-1ph	14W34				X	
	208/230V-3ph	14W37				X	X
	460V-3ph	14W41				X	X
	575V-3ph	14W45				X	X
30 kW	208/230V-3ph	14W38					X
	460V-3ph	14W42					X
	575V-3ph	14W46					X

NOTE - The catalog and model numbers that appear here are for ordering field installed accessories only.

OX - Field Installed or Configure to Order (factory installed)

O - Configure to Order (Factory Installed)

X - Field Installed

OPTIONS / ACCESSORIES

Item	Catalog No.	Unit Model No.					
		KHB 024	KHB 030	KHB 036	KHB 048	KHB 060	KHB 074
INDOOR AIR QUALITY							
Air Filters							
Healthy Climate® High Efficiency Air Filters	MERV 8 (16 x 20 x 2)	54W20	X	X	X		
	MERV 13 (16 x 20 x 2)	52W37	X	X	X		
Order 4 per unit	MERV 8 (20 x 20 x 2)	54W21				X	X
	MERV 13 (20 x 20 x 2)	52W39				X	X
Indoor Air Quality (CO₂) Sensors							
Sensor - Wall-mount, off-white plastic cover with LCD display		77N39	X	X	X	X	X
Sensor - Wall-mount, black plastic case, no display, rated for plenum mounting		87N54	X	X	X	X	X
CO ₂ Sensor Duct Mounting Kit - for downflow applications		85L43	X	X	X	X	X
Aspiration Box - for duct mounting non-plenum rated CO ₂ sensor (77N39)		90N43	X	X	X	X	X
UVC Germicidal Lamps							
¹ Healthy Climate® UVC Light Kit (110/230V-1ph)		21A92	X	X	X	X	X
Step-Down Transformers	460V primary, 230V secondary	10H20	X	X	X	X	X
	575V primary, 230V secondary	10H21	X	X	X	X	X
ROOF CURBS							
Hybrid Roof Curbs, Downflow							
8 in. height		11F50	X	X	X	X	² X
14 in. height		11F51	X	X	X	X	² X
18 in. height		11F52	X	X	X	X	² X
24 in. height		11F53	X	X	X	X	² X
Hybrid Roof Curbs, Full Perimeter, Downflow							
8 in. height		11S47				³ X	X
14 in. height		11S48				³ X	X
18 in. height		11T01				³ X	X
24 in. height		11T06				³ X	X
Adjustable Pitch Curb, Downflow							
14 in. height		43W27	X	X	X	X	² X
CEILING DIFFUSERS							
Step-Down - Order one	RTD9-65S	13K60	X	X	X	X	
	RTD11-95S	13K61					X
Flush - Order one	FD9-65S	13K55	X	X	X	X	
	FD11-95S	13K56					X
Transitions (Supply and Return) - Order one	T1TRAN10AN1	17W53	X	X	X	X	
	T1TRAN20N-1	17W54					X

¹ Lamps operate on 110-230V single-phase power supply. Step-down transformer may be ordered separately for 460V and 575V units. Alternately, 110V power supply may be used to directly power the UVC ballast(s).

² 060H and 074 models will fit smaller roof curbs with overhang. See dimension drawing.

³ 060S models cannot be used on full perimeter curbs.

NOTE - The catalog and model numbers that appear here are for ordering field installed accessories only.

OX - Field Installed or Configure to Order (factory installed)

O - Configure to Order (Factory Installed)

X - Field Installed

SPECIFICATIONS
DIRECT DRIVE BLOWER | STANDARD EFFICIENCY

General Data		Nominal Tonnage	2 Ton	2.5 Ton	3 Ton	4 Ton
		Model No.	KHB024S4D	KHB030S4D	KHB036S4D	KHB048S4D
		Efficiency Type	Standard	Standard	Standard	Standard
		Blower Type	Multi-Speed Direct Drive	Multi-Speed Direct Drive	Multi-Speed Direct Drive	Multi-Speed Direct Drive
Cooling Performance	Gross Cooling Capacity - Btuh		23,700	29,700	36,300	48,700
	¹ Net Cooling Capacity - Btuh		23,000	28,800	35,000	46,500
	AHRI Rated Air Flow - cfm		820	1000	1200	1620
	² Sound Rating Number (SRN) (dBA)		75	75	75	75
	Total Unit Power - kW		2.0	2.4	3.0	4.2
	¹ SEER (Btuh/Watt)		14.0	14.0	14.0	14.0
	¹ EER (Btuh/Watt)		11.0	11.9	11.5	11.4
Heating Performance	Total High Heating Capacity - Btuh		23,000	30,000	36,600	47,500
	Total Unit Power - kW		1.9	2.4	2.9	3.9
	¹ COP		3.76	3.72	3.64	3.72
	¹ HSPF - Region IV (Region V)		8.00 (6.70)	8.00 (6.70)	8.00 (6.70)	8.00 (6.70)
	Total Low Heating Capacity - Btuh		13,000	16,200	20,400	27,400
	Total Unit Power - kW		1.8	2.2	2.7	3.7
	COP		2.28	2.30	2.32	2.40
Refrigerant	Type		R-410A	R-410A	R-410A	R-410A
	Charge Furnished		12 lbs. 8 oz.	12 lbs. 0 oz.	12 lbs. 0 oz.	14 lbs. 7 oz.
Electric Heating Options - See page 12			5, 7.5, 10 kW	5, 7.5, 10 kW	7.5, 15 kW	7.5, 15 kW
Compressor Type (one per unit)			Scroll	Scroll	Scroll	Scroll
Outdoor Coil	Net face area - sq. ft.		15.6	15.6	15.6	19.3
	Tube diameter - in.		3/8	3/8	3/8	3/8
	Number of rows		2	2	2	2
	Fins / inch		20	20	20	20
Outdoor Coil Fan	Motor - (No.) HP		1/4	1/4	1/4	1/4
	Motor rpm		825	825	825	825
	Total Motor Input - watts		220	230	240	290
	Diameter - (No.) in. / No. of blades		(1) 24 - 3	(1) 24 - 3	(1) 24 - 3	(1) 24 - 3
	Total air volume - cfm		3300	3300	3300	3900
Indoor Coil	Net face area - sq. ft.		7.8	7.8	7.8	9.7
	Tube diameter - in.		3/8	3/8	3/8	3/8
	Number of rows		3	3	3	3
	Fins / inch		14	14	14	14
	Drain Connection (no.) and size - in.		(1) 1 NPT	(1) 1 NPT	(1) 1 NPT	(1) 1 NPT
	Expansion device type		Balanced Port Thermostatic Expansion Valve, removable power head			
Indoor Blower	Nominal Motor HP		0.25	0.25	0.5	0.5
	Wheel nom. diameter x width - in.		(1) 10 x 10	(1) 10 x 10	(1) 10 x 10	(1) 10 x 10
Filters	Type		Disposable			Disposable
	Number and size - in.		(4) 16 x 20 x 2			(4) 20 x 20 x 2
Electrical Characteristics - 60 Hz			208/230V - 1 phase		208/230V 1 phase	208/230V 1 phase
					208/230V, 460V & 575V 3 phase	208/230V, 460V & 575V 3 phase

NOTE - Net capacity includes evaporator blower motor heat deduction. Gross capacity does not include evaporator blower motor heat deduction.

¹ AHRI Certified to AHRI Standard 210/240:

Cooling Ratings - 95°F outdoor air temperature and 80°F db/67°F wb entering indoor coil air.

High Temperature Heating Ratings - 47°F db/43°F wb outdoor air temperature and 70°F entering indoor coil air.

Low Temperature Heating Ratings - 17°F db/15°F wb outdoor air temperature and 70°F entering indoor coil air.

² Sound Rating Number (SRN) rated in accordance with test conditions included in ARI Standard 270-95.

SPECIFICATIONS

BELT DRIVE BLOWER | STANDARD EFFICIENCY

General Data		Nominal Tonnage	3 Ton	4 Ton	5 Ton	6 Ton
		Model No.	KHB036S4B	KHB048S4B	KHB060S4B	KHB074S4T
		Efficiency Type	Standard	Standard	Standard	Standard
		Blower Type	Single Speed Belt Drive	Single Speed Belt Drive	Single Speed Belt Drive	Two-Speed Belt Drive
Cooling Performance	Gross Cooling Capacity - Btuh		36,300	48,700	60,600	71,000
	Net Cooling Capacity - Btuh		¹ 35,000	¹ 46,500	¹ 58,000	² 68,000
	AHRI Rated Air Flow - cfm		1200	1620	2020	2100
	³ Sound Rating Number (SRN) (dBA)		75	75	80	83
	Total Unit Power - kW		3.0	4.2	5.0	6.2
	SEER (Btuh/Watt)		¹ 14.0	¹ 14.0	¹ 14.0	---
	IEER (Btuh/Watt)		---	---	---	² 14.0
EER (Btuh/Watt)		¹ 11.55	¹ 11.4	¹ 11.5	² 11.0	
Heating Performance	Total High Heating Capacity - Btuh		36,600	47,500	58,000	70,000
	Total Unit Power - kW		2.9	3.9	4.5	6.1
	¹ COP		3.64	3.72	3.72	3.30
	HSPF - Region IV (Region V)		8.00 (6.70)	8.00 (6.70)	8.00 (6.70)	---
	Total Low Heating Capacity - Btuh		20,400	27,400	33,000	40,000
	Total Unit Power - kW		2.7	3.7	4.2	5.2
	¹ COP		2.32	2.40	2.38	2.25
Refrigerant	Type		R-410A	R-410A	R-410A	R-410A
	Charge Furnished		12 lbs. 0 oz.	14 lbs. 7 oz.	16 lbs. 0 oz.	24 lbs. 0 oz.
Electric Heating Options - See page 12			7.5, 15 kW	7.5, 15 kW	7.5, 15, 22.5 kW	7.5, 15, 22.5, 30 kW
Compressor Type (one per unit)			Scroll	Scroll	Scroll	Two-Stage Scroll
Outdoor Coil	Net face area - sq. ft.		15.6	19.3	19.3	28.0
	Tube diameter - in.		3/8	3/8	3/8	3/8
	Number of rows		2	2	3	2
	Fins / inch		20	20	20	20
Outdoor Coil Fan	Motor - (No.) HP		(1) 1/4	(1) 1/4	(1) 1/3	(1) 1/2
	Motor rpm		825	825	1075	1075
	Total Motor Input - watts		240	290	405	505
	Diameter - (No.) in. / No. of blades		(1) 24 - 3	(1) 24 - 3	(1) 24 - 3	(1) 24 - 4
	Total air volume - cfm		3300	3900	4300	5735
Indoor Coil	Net face area - sq. ft.		7.8	9.7	9.7	9.7
	Tube diameter - in.		3/8	3/8	3/8	3/8
	Number of rows		3	3	4	4
	Fins / inch		14	14	14	14
	Drain Connection (no.) and size - in.		(1) 1 NPT	(1) 1 NPT	(1) 1 NPT	(1) 1 NPT
	Expansion device type		Balanced Port Thermostatic Expansion Valve, removable power head			
⁴ Indoor Blower & Drive Selection	Nominal Motor	208/230V-1ph	0.75 hp, 1.5 hp	0.75 hp, 1.5 hp	0.75 hp, 1.5 hp	---
	HP	All others voltages	1 hp, 2 hp	1 hp, 2 hp	1 hp, 2 hp	1 hp, 2 hp
	Maximum Usable	208/230V-1ph	0.86 hp, 1.7 hp	0.86 hp, 1.7 hp	0.86 hp, 1.7 hp	---
	Motor HP	All other voltages	1.15 hp, 2.3 hp	1.15 hp, 2.3 hp	1.15 hp, 2.3 hp	1.15 hp, 2.3 hp
	Available Drive Kits		A01	A02	A03	A04
			673 - 1010 rpm	745 - 1117 rpm	833 - 1250 rpm	968 - 1340 rpm
			A05	A06	A07	A08
			897 - 1346 rpm	1071 - 1429 rpm	1212 - 1548 rpm	1193-1591 rpm
	Wheel nominal diameter x width - in.		(1) 10 x 10	(1) 10 x 10	(1) 10 x 10	(1) 10 x 10
Filters	Type		Disposable			
	Number and size - in.		(4) 16 x 20 x 2	(4) 20 x 20 x 2		
Electrical Characteristics - 60 Hz			208/230V 1 phase, 208/230V, 460V & 575V 3 phase	208/230V 1 phase, 208/230V, 460V & 575V 3 phase	208/230V 1 phase, 208/230V, 460V & 575V 3 phase	208/230V, 460V & 575V 3 phase

NOTE - Net capacity includes evaporator blower motor heat deduction. Gross capacity does not include evaporator blower motor heat deduction.

^{1,2} AHRI Certified to AHRI Standard ¹ 210/240 or ² 340/360:

Cooling Ratings - 95°F outdoor air temperature and 80°F db/67°F wb entering indoor coil air.

High Temperature Heating Ratings - 47°F db/43°F wb outdoor air temperature and 70°F entering indoor coil air.

Low Temperature Heating Ratings - 17°F db/15°F wb outdoor air temperature and 70°F entering indoor coil air.

³ Sound Rating Number (SRN) rated in accordance with test conditions included in ARI Standard 270-95.

⁴ Using total air volume and system static pressure requirements determine from blower performance tables rpm and motor hp required. Maximum usable hp of motors furnished are shown. In Canada, nominal motor hp is also maximum usable motor hp. If motors of comparable hp are used, be sure to keep within the service factor limitations outlined on the motor nameplate.

SPECIFICATIONS
DIRECT DRIVE BLOWER | HIGH EFFICIENCY

General Data		Nominal Tonnage	2 Ton	3 Ton	4 Ton	5 Ton
		Model No.	KHB024H4E	KHB036H4E	KHB048H4E	KHB060H4E
		Efficiency Type	High	High	High	High
		Blower Type	Direct Drive-ECM	Direct Drive-ECM	Direct Drive-ECM	Direct Drive-ECM
Cooling Performance	Gross Cooling Capacity - Btuh		23,800	35,700	46,800	59,400
	¹ Net Cooling Capacity - Btuh		23,600	35,200	46,000	58,000
	AHRI Rated Air Flow - cfm		800/560	1200/800	1430/1120	1650/1210
	² Sound Rating Number (SRN) (dBA)		74	75	77	77
	Total Unit Power - kW		1.8	2.8	3.6	4.7
	¹ SEER (Btuh/Watt)		16.5	16.0	16.0	16.0
	¹ EER (Btuh/Watt) - 208/230V		13.0	12.7	12.8	12.5
	¹ EER (Btuh/Watt) - 460V/575V		13.0	12.4	12.8	12.5
Refrigerant	Type		R-410A	R-410A	R-410A	R-410A
	Charge Furnished		13 lbs. 0 oz.	12 lbs. 13 oz.	14 lbs. 0 oz.	20 lbs. 0 oz.
Heating Performance	Total High Heating Capacity - Btuh		24,000	35,000	46,000	59,000
	Total Unit Power - kW		1.8	2.6	3.4	4.7
	¹ COP		3.88	3.90	3.90	3.76
	¹ HSPF - Region IV (Region V)		8.30	8.50	8.50	8.50
	Total Low Heating Capacity - Btuh		13,000	19,200	26,000	34,000
	Total Unit Power - kW		1.6	2.3	3.0	4.0
	COP		2.34	2.40	2.46	2.46
	Electric Heating Options - See page 12			5, 7.5, 10 kW	7.5, 15 kW	7.5, 15 kW
Compressor Type (one per unit)			Two-Stage Scroll	Two-Stage Scroll	Two-Stage Scroll	Two-Stage Scroll
Outdoor Coil	Net face area - sq. ft.		15.6	15.6	19.3	28.0
	Tube diameter - in.		3/8	3/8	3/8	3/8
	Number of rows		2	2	2	2
	Fins / inch		20	20	20	20
Outdoor Coil Fan	Motor - (No.) HP		(1) 1/3	(1) 1/3	(1) 1/3	(1) 1/3
	Motor rpm		725/500	775/650	850/700	930/785
	Total Motor Input - watts		165/60	193/125	251/140	236/145
	Diameter - (No.) in. / No. of blades		24 - 3	24 - 3	24 - 3	24 - 3
	Total air volume - cfm		3340/2240	3500/2970	4060/3330	4135/3385
Indoor Coil	Net face area - sq. ft.		7.8	7.8	9.7	9.7
	Tube diameter - in.		3/8	3/8	3/8	3/8
	Number of rows		3	3	3	4
	Fins / inch		14	14	14	14
	Drain Connection (no.) and size - in.		(1) 1 NPT	(1) 1 NPT	(1) 1 NPT	(1) 1 NPT
Expansion device type			Balanced Port Thermostatic Expansion Valve, removable power head			
Indoor Blower	Nominal Motor HP		0.33	0.5	0.75	1
	Wheel nominal diameter x width - in.		(1) 10 x 10	(1) 10 x 10	(1) 10 x 10	(1) 11 x 10
Filters	Type		Disposable		Disposable	
	Number and size - in.		(4) 16 x 20 x 2		(4) 20 x 20 x 2	
Electrical Characteristics - 60 Hz			208/230V 1 phase	208/230V 1 phase 208/230V, 460V & 575V 3 phase	208/230V 1 phase 208/230V, 460V & 575V 3 phase	208/230V 1 phase 208/230V, 460V & 575V 3 phase

NOTE - Net capacity includes evaporator blower motor heat deduction. Gross capacity does not include evaporator blower motor heat deduction.

¹ AHRI Certified to AHRI Standard 210/240:

Cooling Ratings - 95°F outdoor air temperature and 80°F db/67°F wb entering indoor coil air.

High Temperature Heating Ratings - 47°F db/43°F wb outdoor air temperature and 70°F entering indoor coil air.

Low Temperature Heating Ratings - 17°F db/15°F wb outdoor air temperature and 70°F entering indoor coil air.

² Sound Rating Number (SRN) rated in accordance with test conditions included in ARI Standard 270-95.

SPECIFICATIONS

BELT DRIVE BLOWER | HIGH EFFICIENCY

General Data		Nominal Tonnage	3 Ton	4 Ton	5 Ton	
		Model No.	KHB036H4T	KHB048H4T	KHB060H4T	
		Efficiency Type	High	High	High	
		Blower Type	Two Speed Belt Drive	Two Speed Belt Drive	Two Speed Belt Drive	
Cooling Performance	Gross Cooling Capacity - Btuh		36,200	47,600	59,600	
	¹ Net Cooling Capacity - Btuh		35,000	46,000	57,500	
	AHRI Rated Air Flow - cfm		1200	1600	1800	
	² Sound Rating Number (SRN) (dBA)		75	77	77	
	Total Unit Power - kW		3.0	3.8	4.9	
	¹ SEER (Btuh/Watt) - 208/230V		15.0	15.0	15.0	
	¹ SEER (Btuh/Watt) - 460/575V		14.8	14.8	15.0	
	¹ EER (Btuh/Watt) - 208/230V		12.0	12.0	12.0	
¹ EER (Btuh/Watt) - 460/575V		11.8	11.9	11.8		
Refrigerant	Type		R-410A	R-410A	R-410A	
	Charge Furnished		12 lbs. 13 oz.	14 lbs. 0 oz.	20 lbs. 0 oz.	
Heating Performance	Total High Heating Capacity - Btuh		35,000	46,000	59,000	
	Total Unit Power - kW		2.8	3.5	4.7	
	¹ COP		3.64	3.82	3.70	
	HSPF - Region IV (Region V)		8.30	8.30	8.30	
	Total Low Heating Capacity - Btuh		19,200	26,000	34,000	
	Total Unit Power - kW		2.3	3.0	4.0	
	¹ COP		2.22	2.38	2.46	
Electric Heating Options - See page 12			7.5, 15 kW	7.5, 15 kW	7.5, 15, 22.5 kW	
Compressor Type (one per unit)			Two-Stage Scroll	Two-Stage Scroll	Two-Stage Scroll	
Outdoor Coil	Net face area - sq. ft.		15.6	19.3	28.0	
	Tube diameter - in.		3/8	3/8	3/8	
	Number of rows		2	2	2	
	Fins / inch		20	20	20	
Outdoor Coil Fan	Motor - (No.) HP		1/3	1/3	1/3	
	Motor rpm		775/650	850/700	930/785	
	Total Motor Input - watts		195/125	251/140	235/145	
	Diameter - (No.) in. / No. of blades		24 - 3	24 - 3	24 - 3	
	Total air volume - cfm		3500/2970	4060/3330	4135/3385	
Indoor Coil	Net face area - sq. ft.		7.8	9.7	9.7	
	Tube diameter - in.		3/8	3/8	3/8	
	Number of rows		3	3	4	
	Fins / inch		14	14	14	
	Drain Connection (no.) and size - in.		(1) 1 NPT	(1) 1 NPT	(1) 1 NPT	
	Expansion device type		Balanced Port Thermostatic Expansion Valve, removable power head			
³ Indoor Blower & Drive Selection	Nominal Motor HP		0.75 hp (low), 1 hp (high)	0.75 hp (low), 2 hp (high)	1 hp (low), 2 hp (high)	
	Maximum Usable Motor HP		0.86 hp (low), 1.15 hp (high)	0.86 hp (low), 2.3 hp (high)	1.15 hp (low), 2.3 hp (high)	
	Available Drive Kits	A01		low 449-673 high 673-1010	A02 low 497-673 high 745-1117	A03 low 555-833 high 833-1250
		A05		low 598-897 high 897-1346	A06 low 714-953 high 1071-1429	A07 low 808-1032 high 1212-1548
		Wheel nominal diameter x width - in.		(1) 10 x 10	(1) 10 x 10	(1) 10 x 10
	Filters	Type		Disposable	Disposable	
		Number and size - in.		(4) 16 x 20 x 2	(4) 20 x 20 x 2	
Electrical Characteristics - 60 Hz			208/230V, 460V & 575V 3 phase	208/230V, 460V & 575V 3 phase	208/230V, 460V & 575V 3 phase	

NOTE - Net capacity includes evaporator blower motor heat deduction. Gross capacity does not include evaporator blower motor heat deduction.

¹AHRI Certified to AHRI Standard 210/240:

Cooling Ratings - 95°F outdoor air temperature and 80°F db/67°F wb entering indoor coil air.

High Temperature Heating Ratings - 47°F db/43°F wb outdoor air temperature and 70°F entering indoor coil air.

Low Temperature Heating Ratings - 17°F db/15°F wb outdoor air temperature and 70°F entering indoor coil air.

² Sound Rating Number (SRN) rated in accordance with test conditions included in ARI Standard 270-95.

³ Using total air volume and system static pressure requirements determine from blower performance tables rpm and motor hp required. Maximum usable hp of motors furnished are shown. In Canada, nominal motor hp is also maximum usable motor hp. If motors of comparable hp are used, be sure to keep within the service factor limitations outlined on the motor nameplate.

COOLING / HEATING RATINGS

STANDARD EFFICIENCY

NOTE – For Temperatures and Capacities not shown in tables, see bulletin – Cooling Unit Rating Table Correction Factor Data in Miscellaneous Engineering Data section.

2 TON COOLING STANDARD EFFICIENCY KHB024S4

Entering Wet Bulb Temperature	Total Air Volume	Outdoor Air Temperature Entering Outdoor Coil																			
		85°F					95°F					105°F					115°F				
		Total Cool Cap.	Comp. Motor Input	Sensible To Total Ratio (S/T)			Total Cool Cap.	Comp. Motor Input	Sensible To Total Ratio (S/T)			Total Cool Cap.	Comp. Motor Input	Sensible To Total Ratio (S/T)			Total Cool Cap.	Comp. Motor Input	Sensible To Total Ratio (S/T)		
				Dry Bulb					Dry Bulb					Dry Bulb							
cfm	kBtuh	kW	75°F	80°F	85°F	kBtuh	kW	75°F	80°F	85°F	kBtuh	kW	75°F	80°F	85°F	kBtuh	kW	75°F	80°F	85°F	
63°F	640	22	1.36	0.71	0.87	1	20.3	1.55	0.72	0.89	1	18.6	1.78	0.73	0.91	1	16.6	2.03	0.75	0.95	1
	800	23.6	1.35	0.77	0.95	1	21.8	1.54	0.79	0.98	1	20	1.77	0.81	1	1	18.1	2.01	0.84	1	1
	960	24.9	1.33	0.83	1	1	23.2	1.52	0.85	1	1	21.4	1.75	0.88	1	1	19.5	2	0.92	1	1
67°F	640	23.7	1.35	0.55	0.69	0.83	21.9	1.54	0.55	0.7	0.85	20	1.76	0.54	0.71	0.88	18	2.02	0.54	0.73	0.91
	800	25.2	1.33	0.59	0.75	0.91	23.3	1.52	0.59	0.77	0.94	21.3	1.75	0.59	0.79	0.97	19.1	2	0.6	0.82	1
	960	26.3	1.31	0.63	0.81	0.99	24.3	1.51	0.63	0.83	1	22.2	1.73	0.64	0.86	1	19.9	1.99	0.65	0.9	1
71°F	640	25.5	1.33	0.4	0.54	0.67	23.6	1.52	0.39	0.54	0.68	21.7	1.74	0.38	0.54	0.69	19.5	1.99	0.36	0.54	0.71
	800	27	1.3	0.42	0.58	0.73	25.1	1.49	0.42	0.58	0.75	23	1.72	0.4	0.59	0.77	20.7	1.98	0.39	0.6	0.79
	960	28.1	1.28	0.44	0.62	0.79	26.1	1.48	0.43	0.63	0.81	23.9	1.71	0.43	0.64	0.84	21.4	1.96	0.42	0.65	0.88

2 TON HEATING STANDARD EFFICIENCY KHB024S4

Indoor Coil Air Volume 70°F Dry Bulb cfm	Air Temperature Entering Outdoor Coil									
	65°F		45°F		25°F		5°F		-15°F	
	Total Heating Capacity	Comp. Motor Input	Total Heating Capacity	Comp. Motor Input	Total Heating Capacity	Comp. Motor Input	Total Heating Capacity	Comp. Motor Input	Total Heating Capacity	Comp. Motor Input
cfm	kBtuh	kW	kBtuh	kW	kBtuh	kW	kBtuh	kW	kBtuh	kW
640	30.6	1.73	23.2	1.65	15.6	1.57	10.2	1.42	5.1	1.06
800	31	1.6	23.7	1.52	16	1.44	10.7	1.29	5.6	0.94
960	31.4	1.52	24.1	1.44	16.4	1.36	11.1	1.22	6	0.86

2.5 TON COOLING STANDARD EFFICIENCY KHB030S4

Entering Wet Bulb Temperature	Total Air Volume	Outdoor Air Temperature Entering Outdoor Coil																			
		85°F					95°F					105°F					115°F				
		Total Cool Cap.	Comp. Motor Input	Sensible To Total Ratio (S/T)			Total Cool Cap.	Comp. Motor Input	Sensible To Total Ratio (S/T)			Total Cool Cap.	Comp. Motor Input	Sensible To Total Ratio (S/T)			Total Cool Cap.	Comp. Motor Input	Sensible To Total Ratio (S/T)		
				Dry Bulb					Dry Bulb					Dry Bulb							
cfm	kBtuh	kW	75°F	80°F	85°F	kBtuh	kW	75°F	80°F	85°F	kBtuh	kW	75°F	80°F	85°F	kBtuh	kW	75°F	80°F	85°F	
63°F	800	28	1.61	0.74	0.88	1	26.5	1.84	0.76	0.9	1	24.9	2.1	0.78	0.93	1	23.3	2.41	0.8	0.96	1
	1000	29.6	1.62	0.79	0.95	1	28.1	1.85	0.81	0.97	1	26.4	2.11	0.84	1	1	24.8	2.41	0.87	1	1
	1200	31	1.63	0.85	1	1	29.4	1.86	0.87	1	1	27.9	2.12	0.9	1	1	26.1	2.42	0.93	1	1
67°F	800	29.7	1.62	0.59	0.72	0.84	28.2	1.85	0.59	0.73	0.87	26.4	2.12	0.6	0.75	0.89	24.6	2.41	0.62	0.78	0.93
	1000	31.2	1.63	0.62	0.77	0.92	29.5	1.86	0.63	0.79	0.94	27.8	2.12	0.64	0.81	0.97	25.8	2.42	0.66	0.84	1
	1200	32.4	1.64	0.65	0.82	0.98	30.6	1.87	0.66	0.85	1	28.6	2.13	0.68	0.88	1	26.6	2.42	0.7	0.91	1
71°F	800	31.5	1.63	0.45	0.57	0.7	29.8	1.86	0.44	0.58	0.71	28.1	2.12	0.45	0.59	0.73	26.1	2.42	0.45	0.6	0.75
	1000	33.2	1.64	0.45	0.6	0.75	31.3	1.87	0.46	0.62	0.77	29.5	2.13	0.46	0.63	0.79	27.4	2.42	0.47	0.65	0.82
	1200	34.4	1.65	0.47	0.64	0.8	32.4	1.88	0.47	0.65	0.82	30.4	2.14	0.48	0.67	0.85	28.2	2.43	0.49	0.69	0.88

2.5 TON HEATING STANDARD EFFICIENCY KHB030S4

Indoor Coil Air Volume 70°F Dry Bulb cfm	Air Temperature Entering Outdoor Coil									
	65°F		45°F		25°F		5°F		-15°F	
	Total Heating Capacity	Comp. Motor Input	Total Heating Capacity	Comp. Motor Input	Total Heating Capacity	Comp. Motor Input	Total Heating Capacity	Comp. Motor Input	Total Heating Capacity	Comp. Motor Input
cfm	kBtuh	kW	kBtuh	kW	kBtuh	kW	kBtuh	kW	kBtuh	kW
800	37.2	2.12	28.1	2.01	18.8	1.89	12.1	1.7	6.1	1.28
1000	37.8	1.96	28.7	1.85	19.3	1.74	12.7	1.55	6.6	1.12
1200	38.2	1.87	29.2	1.76	19.8	1.64	13.1	1.45	7.1	1.03

COOLING / HEATING RATINGS

STANDARD EFFICIENCY

NOTE – For Temperatures and Capacities not shown in tables, see bulletin – Cooling Unit Rating Table Correction Factor Data in Miscellaneous Engineering Data section.

3 TON COOLING STANDARD EFFICIENCY KHB036S4

Entering Wet Bulb Temperature	Total Air Volume	Outdoor Air Temperature Entering Outdoor Coil																			
		85°F					95°F					105°F					115°F				
		Total Cool Cap.	Comp. Motor Input	Sensible To Total Ratio (S/T)			Total Cool Cap.	Comp. Motor Input	Sensible To Total Ratio (S/T)			Total Cool Cap.	Comp. Motor Input	Sensible To Total Ratio (S/T)			Total Cool Cap.	Comp. Motor Input	Sensible To Total Ratio (S/T)		
				Dry Bulb					Dry Bulb					Dry Bulb							
cfm	kBtuh	kW	75°F	80°F	85°F	kBtuh	kW	75°F	80°F	85°F	kBtuh	kW	75°F	80°F	85°F	kBtuh	kW	75°F	80°F	85°F	
63°F	960	34.7	2.1	0.71	0.87	1	32.3	2.37	0.73	0.89	1	29.7	2.69	0.74	0.92	1	26.9	3.06	0.77	0.96	1
	1200	36.9	2.11	0.77	0.95	1	34.3	2.38	0.79	0.98	1	31.5	2.7	0.82	1	1	29	3.06	0.85	1	1
	1440	38.5	2.12	0.83	1	1	36.1	2.39	0.86	1	1	33.6	2.71	0.89	1	1	30.9	3.07	0.93	1	1
67°F	960	37.1	2.11	0.56	0.69	0.83	34.6	2.38	0.56	0.71	0.85	31.8	2.7	0.56	0.72	0.88	28.9	3.06	0.57	0.74	0.92
	1200	39.1	2.12	0.59	0.75	0.91	36.4	2.39	0.6	0.77	0.94	33.4	2.7	0.61	0.8	0.98	30.4	3.07	0.62	0.83	1
	1440	40.5	2.13	0.63	0.81	0.99	37.7	2.41	0.64	0.84	1	34.8	2.71	0.65	0.87	1	31.6	3.08	0.66	0.9	1
71°F	960	39.5	2.12	0.41	0.54	0.67	36.8	2.4	0.4	0.55	0.68	34.1	2.71	0.4	0.55	0.7	31	3.07	0.39	0.56	0.72
	1200	41.5	2.14	0.43	0.58	0.73	38.9	2.41	0.42	0.59	0.75	35.9	2.72	0.42	0.6	0.77	32.7	3.08	0.42	0.61	0.8
	1440	43.1	2.15	0.45	0.62	0.79	40.2	2.41	0.45	0.63	0.81	37.1	2.73	0.44	0.65	0.84	33.7	3.09	0.44	0.67	0.88

3 TON HEATING STANDARD EFFICIENCY KHB036S4

Indoor Coil Air Volume 70°F Dry Bulb cfm	Air Temperature Entering Outdoor Coil									
	65°F		45°F		25°F		5°F		-15°F	
	Total Heating Capacity	Comp. Motor Input	Total Heating Capacity	Comp. Motor Input	Total Heating Capacity	Comp. Motor Input	Total Heating Capacity	Comp. Motor Input	Total Heating Capacity	Comp. Motor Input
	kBtuh	kW	kBtuh	kW	kBtuh	kW	kBtuh	kW	kBtuh	kW
960	45.2	2.61	34.5	2.45	23.3	2.28	15.4	2.03	7.7	1.52
1200	45.8	2.45	35.1	2.28	23.9	2.12	16	1.86	8.3	1.36
1440	46.4	2.35	35.6	2.18	24.5	2.02	16.5	1.77	8.9	1.26

4 TON COOLING STANDARD EFFICIENCY KHB048S4

Entering Wet Bulb Temperature	Total Air Volume	Outdoor Air Temperature Entering Outdoor Coil																			
		85°F					95°F					105°F					115°F				
		Total Cool Cap.	Comp. Motor Input	Sensible To Total Ratio (S/T)			Total Cool Cap.	Comp. Motor Input	Sensible To Total Ratio (S/T)			Total Cool Cap.	Comp. Motor Input	Sensible To Total Ratio (S/T)			Total Cool Cap.	Comp. Motor Input	Sensible To Total Ratio (S/T)		
				Dry Bulb					Dry Bulb					Dry Bulb							
cfm	kBtuh	kW	75°F	80°F	85°F	kBtuh	kW	75°F	80°F	85°F	kBtuh	kW	75°F	80°F	85°F	kBtuh	kW	75°F	80°F	85°F	
63°F	1280	46	2.86	0.71	0.86	1	42.2	3.25	0.71	0.88	1	38.2	3.69	0.72	0.91	1	33.9	4.21	0.74	0.95	1
	1600	49.1	2.87	0.77	0.95	1	45	3.26	0.79	0.98	1	41.1	3.71	0.81	1	1	37.1	4.23	0.83	1	1
	1920	51.9	2.88	0.84	1	1	48	3.27	0.86	1	1	44.2	3.73	0.88	1	1	40	4.26	0.93	1	1
67°F	1280	49.4	2.87	0.54	0.68	0.83	45.4	3.26	0.54	0.69	0.85	41.2	3.71	0.53	0.7	0.87	36.9	4.23	0.53	0.72	0.91
	1600	52.5	2.89	0.58	0.75	0.92	48.2	3.27	0.58	0.77	0.95	44	3.73	0.58	0.79	0.98	39.3	4.24	0.59	0.81	1
	1920	54.8	2.9	0.62	0.82	0.99	50.4	3.29	0.63	0.84	1	45.8	3.74	0.63	0.86	1	41	4.26	0.65	0.9	1
71°F	1280	53	2.88	0.39	0.53	0.66	48.8	3.27	0.38	0.53	0.67	44.6	3.73	0.36	0.52	0.68	40.1	4.25	0.34	0.52	0.7
	1600	56.1	2.9	0.42	0.58	0.73	51.7	3.29	0.4	0.58	0.75	47.4	3.75	0.39	0.58	0.77	42.4	4.27	0.37	0.59	0.79
	1920	58.4	2.92	0.44	0.62	0.8	53.9	3.31	0.43	0.63	0.82	49.1	3.76	0.42	0.63	0.84	43.9	4.29	0.4	0.65	0.88

4 TON HEATING STANDARD EFFICIENCY KHB048S4

Indoor Coil Air Volume 70°F Dry Bulb cfm	Air Temperature Entering Outdoor Coil									
	65°F		45°F		25°F		5°F		-15°F	
	Total Heating Capacity	Comp. Motor Input	Total Heating Capacity	Comp. Motor Input	Total Heating Capacity	Comp. Motor Input	Total Heating Capacity	Comp. Motor Input	Total Heating Capacity	Comp. Motor Input
	kBtuh	kW	kBtuh	kW	kBtuh	kW	kBtuh	kW	kBtuh	kW
1280	60	3.34	46.3	3.19	32	3.04	21.6	2.76	10.6	2.06
1600	61.1	3.11	47.4	2.96	33.1	2.81	22.7	2.53	11.7	1.83
1920	61.9	2.96	48.2	2.81	34	2.66	23.5	2.37	12.6	1.67

COOLING / HEATING RATINGS

STANDARD EFFICIENCY

NOTE – For Temperatures and Capacities not shown in tables, see bulletin – Cooling Unit Rating Table Correction Factor Data in Miscellaneous Engineering Data section.

5 TON COOLING STANDARD EFFICIENCY KHB060S4

Entering Wet Bulb Temperature	Total Air Volume	Outdoor Air Temperature Entering Outdoor Coil																			
		85°F					95°F					105°F					115°F				
		Total Cool Cap.	Comp. Motor Input	Sensible To Total Ratio (S/T)			Total Cool Cap.	Comp. Motor Input	Sensible To Total Ratio (S/T)			Total Cool Cap.	Comp. Motor Input	Sensible To Total Ratio (S/T)			Total Cool Cap.	Comp. Motor Input	Sensible To Total Ratio (S/T)		
				Dry Bulb					Dry Bulb					Dry Bulb					Dry Bulb		
cfm	kBtuh	kW	75°F	80°F	85°F	kBtuh	kW	75°F	80°F	85°F	kBtuh	kW	75°F	80°F	85°F	kBtuh	kW	75°F	80°F	85°F	
63°F	1600	59.2	3.45	0.69	0.86	1	54.8	3.89	0.7	0.88	1	50.2	4.42	0.71	0.92	1	45.4	5.05	0.73	0.96	1
	2000	62.6	3.46	0.75	0.96	1	58.3	3.91	0.77	0.99	1	53.7	4.44	0.8	1	1	49.2	5.09	0.82	1	1
	2400	65.9	3.48	0.82	1	1	61.8	3.93	0.84	1	1	57.3	4.47	0.88	1	1	52.5	5.12	0.93	1	1
67°F	1600	63.7	3.47	0.53	0.67	0.81	59.1	3.92	0.53	0.68	0.83	54.3	4.45	0.53	0.69	0.87	49.3	5.09	0.54	0.71	0.92
	2000	67	3.49	0.57	0.73	0.91	62.4	3.94	0.58	0.75	0.94	57.3	4.47	0.58	0.77	0.99	51.7	5.11	0.59	0.8	1
	2400	69.7	3.5	0.61	0.8	1	64.6	3.95	0.61	0.82	1	59.4	4.49	0.63	0.86	1	53.5	5.12	0.64	0.9	1
71°F	1600	68.2	3.49	0.39	0.52	0.65	63.6	3.94	0.38	0.52	0.65	58.6	4.48	0.37	0.52	0.67	53.3	5.12	0.36	0.53	0.69
	2000	71.8	3.51	0.41	0.56	0.7	66.9	3.96	0.4	0.57	0.72	61.5	4.5	0.4	0.58	0.75	55.8	5.15	0.39	0.59	0.78
	2400	74.4	3.52	0.43	0.6	0.77	69.1	3.98	0.42	0.61	0.8	63.7	4.52	0.42	0.62	0.83	57.6	5.16	0.42	0.64	0.88

5 TON HEATING STANDARD EFFICIENCY KHB060S4

Indoor Coil Air Volume 70°F Dry Bulb cfm	Air Temperature Entering Outdoor Coil									
	65°F		45°F		25°F		5°F		-15°F	
	Total Heating Capacity	Comp. Motor Input	Total Heating Capacity	Comp. Motor Input	Total Heating Capacity	Comp. Motor Input	Total Heating Capacity	Comp. Motor Input	Total Heating Capacity	Comp. Motor Input
	kBtuh	kW	kBtuh	kW	kBtuh	kW	kBtuh	kW	kBtuh	kW
1600	71.6	3.92	55.2	3.68	38.4	3.43	25.3	3.08	12.8	2.31
2000	72.3	3.66	55.9	3.42	39	3.17	26	2.82	13.5	2.05
2400	73.5	3.5	57.1	3.26	40.2	3.02	27.2	2.66	14.7	1.89

6 TON COOLING STANDARD EFFICIENCY KHB074S4 (1ST STAGE)

Entering Wet Bulb Temperature	Total Air Volume	Outdoor Air Temperature Entering Outdoor Coil																			
		65°F					75°F					85°F					95°F				
		Total Cool Cap.	Comp. Motor Input	Sensible To Total Ratio (S/T)			Total Cool Cap.	Comp. Motor Input	Sensible To Total Ratio (S/T)			Total Cool Cap.	Comp. Motor Input	Sensible To Total Ratio (S/T)			Total Cool Cap.	Comp. Motor Input	Sensible To Total Ratio (S/T)		
				Dry Bulb					Dry Bulb					Dry Bulb					Dry Bulb		
cfm	kBtuh	kW	75°F	80°F	85°F	kBtuh	kW	75°F	80°F	85°F	kBtuh	kW	75°F	80°F	85°F	kBtuh	kW	75°F	80°F	85°F	
63°F	1200	52.1	2.23	0.7	0.81	0.92	49.9	2.55	0.7	0.82	0.94	47.4	2.9	0.7	0.83	0.96	44.7	3.33	0.72	0.85	0.98
	1600	56.6	2.22	0.74	0.88	1	54.2	2.54	0.75	0.9	1	51.5	2.9	0.77	0.92	1	48.5	3.32	0.78	0.95	1
	2000	59.9	2.2	0.8	0.95	1	57.3	2.52	0.81	0.97	1	54.5	2.89	0.83	0.99	1	51.6	3.3	0.85	1	1
67°F	1200	55.8	2.22	0.55	0.67	0.77	53.5	2.54	0.55	0.67	0.78	51	2.9	0.56	0.68	0.79	48.2	3.32	0.56	0.69	0.81
	1600	60.5	2.2	0.58	0.72	0.85	57.9	2.52	0.59	0.73	0.86	55.1	2.89	0.59	0.74	0.88	52	3.3	0.6	0.76	0.91
	2000	63.8	2.19	0.62	0.77	0.92	61	2.51	0.63	0.79	0.94	58	2.88	0.63	0.8	0.96	54.5	3.29	0.64	0.82	0.99
71°F	1200	59.9	2.21	0.43	0.53	0.64	57.4	2.52	0.43	0.54	0.65	54.7	2.88	0.42	0.54	0.65	51.7	3.3	0.42	0.54	0.66
	1600	64.8	2.18	0.45	0.57	0.7	61.9	2.5	0.44	0.57	0.7	59	2.87	0.44	0.58	0.71	55.7	3.29	0.43	0.59	0.73
	2000	68.2	2.16	0.45	0.6	0.75	65.2	2.49	0.45	0.61	0.76	61.9	2.86	0.46	0.62	0.78	58.4	3.28	0.46	0.63	0.8

6 TON COOLING STANDARD EFFICIENCY KHB074S4 (2ND STAGE)

Entering Wet Bulb Temperature	Total Air Volume	Outdoor Air Temperature Entering Outdoor Coil																			
		85°F					95°F					105°F					115°F				
		Total Cool Cap.	Comp. Motor Input	Sensible To Total Ratio (S/T)			Total Cool Cap.	Comp. Motor Input	Sensible To Total Ratio (S/T)			Total Cool Cap.	Comp. Motor Input	Sensible To Total Ratio (S/T)			Total Cool Cap.	Comp. Motor Input	Sensible To Total Ratio (S/T)		
				Dry Bulb					Dry Bulb					Dry Bulb					Dry Bulb		
cfm	kBtuh	kW	75°F	80°F	85°F	kBtuh	kW	75°F	80°F	85°F	kBtuh	kW	75°F	80°F	85°F	kBtuh	kW	75°F	80°F	85°F	
63°F	1920	66.8	4.21	0.75	0.89	1	63.1	4.77	0.76	0.91	1	59.3	5.42	0.77	0.93	1	55.1	6.17	0.8	0.97	1
	2400	70.3	4.24	0.8	0.96	1	66.4	4.8	0.82	0.98	1	62.5	5.44	0.84	1	1	58.7	6.19	0.87	1	1
	2880	73.4	4.26	0.85	1	1	69.8	4.82	0.88	1	1	66	5.47	0.9	1	1	61.9	6.22	0.94	1	1
67°F	1920	71.1	4.24	0.58	0.72	0.85	67.1	4.8	0.59	0.73	0.87	63.1	5.45	0.59	0.75	0.9	58.7	6.2	0.61	0.77	0.93
	2400	74.6	4.27	0.62	0.78	0.93	70.5	4.83	0.63	0.8	0.95	66	5.47	0.64	0.82	0.98	61.3	6.21	0.65	0.85	1
	2880	77	4.29	0.65	0.84	0.99	72.6	4.85	0.67	0.86	1	68.1	5.49	0.68	0.88	1	63.1	6.22	0.7	0.92	1
71°F	1920	75.5	4.27	0.44	0.57	0.7	71.5	4.83	0.44	0.58	0.71	67.1	5.47	0.44	0.58	0.73	62.5	6.23	0.43	0.59	0.75
	2400	79	4.3	0.45	0.61	0.75	74.6	4.87	0.45	0.61	0.77	70.1	5.51	0.45	0.63	0.8	65.3	6.25	0.46	0.64	0.82
	2880	81.5	4.33	0.47	0.64	0.81	77.1	4.89	0.47	0.66	0.83	72.3	5.53	0.47	0.67	0.86	67.2	6.25	0.48	0.69	0.89

6 TON HEATING STANDARD EFFICIENCY KHB074S4

Indoor Coil Air Volume 70°F Dry Bulb cfm	Air Temperature Entering Outdoor Coil									
	65°F		45°F		25°F		5°F		-15°F	
	Total Heating Capacity	Comp. Motor Input	Total Heating Capacity	Comp. Motor Input	Total Heating Capacity	Comp. Motor Input	Total Heating Capacity	Comp. Motor Input	Total Heating Capacity	Comp. Motor Input
	kBtuh	kW	kBtuh	kW	kBtuh	kW	kBtuh	kW	kBtuh	kW
1920	84.3	5.21	68.2	4.85	52.1	4.49	34.9	3.99	17.0	3.00
2400	85.8	4.86	69.6	4.51	53.6	4.15	36.4	3.65	18.5	2.66
2880	86.9	4.65	70.7	4.29	54.7	3.94	37.5	3.43	19.6	2.44

COOLING / HEATING RATINGS

HIGH EFFICIENCY

NOTE – For Temperatures and Capacities not shown in tables, see bulletin – Cooling Unit Rating Table Correction Factor Data in Miscellaneous Engineering Data section.

2 TON COOLING HIGH EFFICIENCY KHB024H4 (1ST STAGE)

Entering Wet Bulb Temperature	Total Air Volume	Outdoor Air Temperature Entering Outdoor Coil																			
		65°F					75°F					85°F					95°F				
		Total Cool Cap.	Comp. Motor Input	Sensible To Total Ratio (S/T)			Total Cool Cap.	Comp. Motor Input	Sensible To Total Ratio (S/T)			Total Cool Cap.	Comp. Motor Input	Sensible To Total Ratio (S/T)			Total Cool Cap.	Comp. Motor Input	Sensible To Total Ratio (S/T)		
				Dry Bulb					Dry Bulb					Dry Bulb					Dry Bulb		
cfm	kBtuh	kW	75°F	80°F	85°F	kBtuh	kW	75°F	80°F	85°F	kBtuh	kW	75°F	80°F	85°F	kBtuh	kW	75°F	80°F	85°F	
63°F	450	17.9	.77	0.69	0.82	0.95	17.1	.89	0.69	0.83	0.96	16.0	1.03	0.70	0.85	0.99	14.8	1.20	0.71	0.87	1.00
	560	19.2	.76	0.74	0.88	1.00	18.3	.88	0.74	0.90	1.00	17.1	1.02	0.76	0.92	1.00	15.8	1.19	0.77	0.96	1.00
	670	20.2	.75	0.78	0.95	1.00	19.2	.87	0.79	0.97	1.00	17.9	1.02	0.81	1.00	1.00	16.7	1.18	0.84	1.00	1.00
67°F	450	19.2	.76	0.55	0.67	0.78	18.3	.88	0.55	0.67	0.79	17.2	1.02	0.55	0.68	0.81	15.9	1.19	0.55	0.69	0.83
	560	20.4	.75	0.58	0.71	0.85	19.4	.87	0.58	0.72	0.86	18.2	1.01	0.58	0.73	0.89	16.9	1.18	0.59	0.75	0.92
	670	21.4	.74	0.60	0.76	0.91	20.3	.86	0.61	0.77	0.94	19.0	1.00	0.61	0.79	0.96	17.6	1.17	0.62	0.81	1.00
71°F	450	20.5	.75	0.42	0.54	0.64	19.5	.87	0.42	0.53	0.65	18.3	1.01	0.41	0.54	0.66	17.0	1.18	0.40	0.54	0.67
	560	21.8	.74	0.44	0.57	0.69	20.7	.86	0.43	0.57	0.70	19.5	1.00	0.42	0.57	0.71	18.0	1.16	0.42	0.58	0.73
	670	22.8	.73	0.45	0.59	0.74	21.6	.85	0.45	0.60	0.75	20.3	.99	0.44	0.61	0.77	18.8	1.16	0.43	0.62	0.79

2 TON COOLING HIGH EFFICIENCY KHB024H4 (2ND STAGE)

Entering Wet Bulb Temperature	Total Air Volume	Outdoor Air Temperature Entering Outdoor Coil																			
		85°F					95°F					105°F					115°F				
		Total Cool Cap.	Comp. Motor Input	Sensible To Total Ratio (S/T)			Total Cool Cap.	Comp. Motor Input	Sensible To Total Ratio (S/T)			Total Cool Cap.	Comp. Motor Input	Sensible To Total Ratio (S/T)			Total Cool Cap.	Comp. Motor Input	Sensible To Total Ratio (S/T)		
				Dry Bulb					Dry Bulb					Dry Bulb					Dry Bulb		
cfm	kBtuh	kW	75°F	80°F	85°F	kBtuh	kW	75°F	80°F	85°F	kBtuh	kW	75°F	80°F	85°F	kBtuh	kW	75°F	80°F	85°F	
63°F	640	22.6	1.39	0.71	0.86	1.00	20.8	1.55	0.72	0.88	1.00	18.9	1.74	0.73	0.91	1.00	16.9	1.97	0.75	0.95	1.00
	800	24.0	1.39	0.77	0.94	1.00	22.2	1.56	0.79	0.97	1.00	20.3	1.75	0.81	1.00	1.00	18.5	1.97	0.83	1.00	1.00
	960	25.3	1.40	0.83	1.00	1.00	23.6	1.56	0.85	1.00	1.00	21.7	1.75	0.88	1.00	1.00	19.8	1.98	0.92	1.00	1.00
67°F	640	24.2	1.39	0.55	0.69	0.83	22.4	1.56	0.55	0.70	0.85	20.4	1.75	0.54	0.71	0.87	18.4	1.98	0.54	0.73	0.91
	800	25.7	1.40	0.59	0.75	0.90	23.8	1.56	0.59	0.76	0.93	21.7	1.75	0.59	0.79	0.96	19.5	1.98	0.60	0.81	1.00
	960	26.8	1.40	0.63	0.81	0.98	24.7	1.57	0.63	0.83	1.00	22.6	1.75	0.64	0.86	1.00	20.3	1.98	0.65	0.89	1.00
71°F	640	25.9	1.40	0.41	0.54	0.67	24.0	1.56	0.39	0.54	0.68	22.0	1.75	0.39	0.54	0.69	20.0	1.98	0.36	0.54	0.71
	800	27.5	1.40	0.43	0.58	0.73	25.5	1.57	0.41	0.58	0.75	23.3	1.76	0.40	0.59	0.76	21.1	1.98	0.38	0.60	0.79
	960	28.6	1.41	0.44	0.62	0.79	26.5	1.57	0.44	0.63	0.81	24.2	1.76	0.43	0.64	0.84	21.8	1.98	0.42	0.65	0.87

2 TON HEATING HIGH EFFICIENCY KHB024H4

Indoor Coil Air Volume 70°F Dry Bulb cfm	Air Temperature Entering Outdoor Coil									
	65°F		45°F		25°F		5°F		-15°F	
	Total Heating Capacity	Comp. Motor Input	Total Heating Capacity	Comp. Motor Input	Total Heating Capacity	Comp. Motor Input	Total Heating Capacity	Comp. Motor Input	Total Heating Capacity	Comp. Motor Input
640	29.8	1.80	22.1	1.66	14.2	1.51	8.6	1.35	4.4	1.02
800	30.4	1.69	22.7	1.54	14.8	1.39	9.2	1.24	4.9	0.90
960	30.7	1.62	23.1	1.47	15.1	1.33	9.5	1.17	5.3	0.83

COOLING / HEATING RATINGS

HIGH EFFICIENCY

NOTE – For Temperatures and Capacities not shown in tables, see bulletin – Cooling Unit Rating Table Correction Factor Data in Miscellaneous Engineering Data section.

3 TON COOLING HIGH EFFICIENCY KHB036H4 (1ST STAGE)

Entering Wet Bulb Temperature	Total Air Volume	Outdoor Air Temperature Entering Outdoor Coil																							
		65°F						75°F						85°F						95°F					
		Total Cool Cap.	Comp. Motor Input	Sensible To Total Ratio (S/T)			Total Cool Cap.	Comp. Motor Input	Sensible To Total Ratio (S/T)			Total Cool Cap.	Comp. Motor Input	Sensible To Total Ratio (S/T)			Total Cool Cap.	Comp. Motor Input	Sensible To Total Ratio (S/T)						
				Dry Bulb					Dry Bulb					Dry Bulb					Dry Bulb						
cfm	kBtuh	kW	75°F	80°F	85°F	kBtuh	kW	75°F	80°F	85°F	kBtuh	kW	75°F	80°F	85°F	kBtuh	kW	75°F	80°F	85°F					
63°F	640	26.3	1.10	0.68	0.81	0.94	24.8	1.25	0.69	0.83	0.97	23.1	1.44	0.70	0.85	1.00	21.4	1.67	0.71	0.87	1.00				
	800	28.1	1.08	0.73	0.88	1.00	26.4	1.24	0.74	0.90	1.00	24.7	1.43	0.75	0.93	1.00	22.9	1.67	0.77	0.97	1.00				
	960	29.4	1.07	0.78	0.96	1.00	27.7	1.23	0.79	0.98	1.00	26.0	1.43	0.81	1.00	1.00	24.3	1.66	0.84	1.00	1.00				
67°F	640	28.2	1.09	0.54	0.66	0.77	26.5	1.24	0.54	0.66	0.79	24.9	1.43	0.54	0.67	0.81	23.1	1.66	0.54	0.69	0.83				
	800	29.9	1.07	0.57	0.71	0.85	28.2	1.23	0.57	0.71	0.86	26.4	1.42	0.58	0.73	0.89	24.5	1.66	0.58	0.75	0.92				
	960	31.1	1.06	0.60	0.75	0.92	29.4	1.22	0.60	0.77	0.94	27.5	1.42	0.61	0.79	0.97	25.6	1.65	0.62	0.81	1.00				
71°F	640	29.9	1.07	0.42	0.53	0.63	28.3	1.23	0.41	0.53	0.64	26.6	1.42	0.40	0.53	0.65	24.8	1.66	0.40	0.53	0.66				
	800	31.8	1.06	0.43	0.56	0.68	30.1	1.22	0.42	0.56	0.69	28.2	1.41	0.42	0.56	0.71	26.3	1.65	0.42	0.57	0.72				
	960	33.1	1.05	0.44	0.59	0.73	31.4	1.21	0.44	0.59	0.74	29.5	1.41	0.44	0.60	0.76	27.4	1.64	0.43	0.61	0.78				

3 TON COOLING HIGH EFFICIENCY KHB036H4 (2ND STAGE)

Entering Wet Bulb Temperature	Total Air Volume	Outdoor Air Temperature Entering Outdoor Coil																							
		85°F						95°F						105°F						115°F					
		Total Cool Cap.	Comp. Motor Input	Sensible To Total Ratio (S/T)			Total Cool Cap.	Comp. Motor Input	Sensible To Total Ratio (S/T)			Total Cool Cap.	Comp. Motor Input	Sensible To Total Ratio (S/T)			Total Cool Cap.	Comp. Motor Input	Sensible To Total Ratio (S/T)						
				Dry Bulb					Dry Bulb					Dry Bulb					Dry Bulb						
cfm	kBtuh	kW	75°F	80°F	85°F	kBtuh	kW	75°F	80°F	85°F	kBtuh	kW	75°F	80°F	85°F	kBtuh	kW	75°F	80°F	85°F					
63°F	960	34.0	2.14	0.70	0.86	1.00	31.5	2.40	0.71	0.88	1.00	28.9	2.72	0.73	0.91	1.00	26.1	3.08	0.75	0.95	1.00				
	1200	36.1	2.15	0.76	0.94	1.00	33.5	2.42	0.78	0.97	1.00	30.7	2.73	0.81	1.00	1.00	28.0	3.09	0.84	1.00	1.00				
	1440	37.8	2.16	0.83	1.00	1.00	35.4	2.43	0.85	1.00	1.00	32.7	2.74	0.88	1.00	1.00	29.9	3.10	0.92	1.00	1.00				
67°F	960	36.4	2.15	0.55	0.68	0.82	33.9	2.42	0.55	0.69	0.84	31.1	2.73	0.55	0.71	0.87	28.1	3.09	0.55	0.72	0.91				
	1200	38.5	2.17	0.58	0.74	0.91	35.7	2.43	0.59	0.76	0.94	32.8	2.74	0.59	0.78	0.97	29.5	3.10	0.60	0.81	1.00				
	1440	40.0	2.18	0.62	0.81	0.98	37.0	2.44	0.63	0.83	1.00	34.0	2.75	0.64	0.85	1.00	30.7	3.10	0.65	0.89	1.00				
71°F	960	38.8	2.17	0.41	0.53	0.66	36.2	2.43	0.40	0.54	0.67	33.3	2.74	0.39	0.54	0.69	30.2	3.10	0.37	0.54	0.70				
	1200	41.0	2.19	0.42	0.57	0.72	38.1	2.45	0.42	0.58	0.74	35.1	2.75	0.41	0.59	0.76	31.8	3.11	0.40	0.60	0.79				
	1440	42.5	2.20	0.44	0.61	0.78	39.5	2.46	0.44	0.62	0.81	36.4	2.76	0.43	0.63	0.83	32.9	3.12	0.43	0.65	0.87				

3 TON HEATING HIGH EFFICIENCY KHB036H4

Indoor Coil Air Volume 70°F Dry Bulb cfm	Air Temperature Entering Outdoor Coil														
	65°F			45°F			25°F			5°F			-15°F		
	Total Heating Capacity	Comp. Motor Input	Total Heating Capacity	Comp. Motor Input	Total Heating Capacity	Comp. Motor Input	Total Heating Capacity	Comp. Motor Input	Total Heating Capacity	Comp. Motor Input	Total Heating Capacity	Comp. Motor Input	Total Heating Capacity	Comp. Motor Input	
															kBtuh
960	43.8	2.62	32.6	2.44	20.9	2.25	13.3	1.99	6.8	1.50					
1200	44.4	2.45	33.2	2.26	21.6	2.07	13.9	1.82	7.4	1.33					
1440	45.0	2.35	33.8	2.16	22.1	1.97	14.5	1.72	8.0	1.22					

COOLING / HEATING RATINGS

HIGH EFFICIENCY

NOTE – For Temperatures and Capacities not shown in tables, see bulletin – Cooling Unit Rating Table Correction Factor Data in Miscellaneous Engineering Data section.

4 TON COOLING HIGH EFFICIENCY KHB048H4 (1ST STAGE)

Entering Wet Bulb Temperature	Total Air Volume	Outdoor Air Temperature Entering Outdoor Coil																							
		65°F						75°F						85°F						95°F					
		Total Cool Cap.	Comp. Motor Input	Sensible To Total Ratio (S/T)			Total Cool Cap.	Comp. Motor Input	Sensible To Total Ratio (S/T)			Total Cool Cap.	Comp. Motor Input	Sensible To Total Ratio (S/T)			Total Cool Cap.	Comp. Motor Input	Sensible To Total Ratio (S/T)						
				Dry Bulb					Dry Bulb					Dry Bulb					Dry Bulb						
cfm	kBtuh	kW	75°F	80°F	85°F	kBtuh	kW	75°F	80°F	85°F	kBtuh	kW	75°F	80°F	85°F	kBtuh	kW	75°F	80°F	85°F					
63°F	895	35.9	1.43	0.70	0.83	0.96	34.0	1.68	0.71	0.85	0.98	31.9	1.97	0.72	0.87	1.00	29.6	2.29	0.74	0.89	1.00				
	1120	38.0	1.41	0.75	0.90	1.00	36.1	1.66	0.76	0.92	1.00	34.0	1.95	0.78	0.95	1.00	31.5	2.27	0.80	0.98	1.00				
	1345	39.9	1.39	0.80	0.97	1.00	37.9	1.65	0.82	0.99	1.00	35.7	1.94	0.84	1.00	1.00	33.5	2.26	0.87	1.00	1.00				
67°F	895	38.2	1.41	0.56	0.68	0.80	36.3	1.66	0.56	0.69	0.81	34.1	1.95	0.56	0.70	0.83	31.7	2.27	0.56	0.71	0.86				
	1120	40.6	1.39	0.59	0.73	0.87	38.5	1.65	0.59	0.74	0.89	36.2	1.94	0.60	0.76	0.91	33.6	2.26	0.61	0.78	0.94				
	1345	42.4	1.38	0.62	0.78	0.93	40.2	1.64	0.63	0.79	0.96	37.7	1.93	0.64	0.81	0.98	35.0	2.25	0.64	0.84	1.00				
71°F	895	40.6	1.39	0.43	0.54	0.66	38.6	1.65	0.42	0.54	0.66	36.4	1.94	0.42	0.55	0.67	33.8	2.26	0.41	0.55	0.69				
	1120	43.0	1.37	0.44	0.57	0.71	41.0	1.63	0.44	0.58	0.72	38.5	1.92	0.43	0.59	0.73	35.9	2.25	0.43	0.60	0.75				
	1345	44.9	1.36	0.45	0.61	0.76	42.8	1.62	0.45	0.62	0.77	40.1	1.92	0.45	0.63	0.79	37.3	2.24	0.45	0.64	0.81				

4 TON COOLING HIGH EFFICIENCY KHB048H4 (2ND STAGE)

Entering Wet Bulb Temperature	Total Air Volume	Outdoor Air Temperature Entering Outdoor Coil																			
		85°F					95°F					105°F					115°F				
		Total Cool Cap.	Comp. Motor Input	Sensible To Total Ratio (S/T)			Total Cool Cap.	Comp. Motor Input	Sensible To Total Ratio (S/T)			Total Cool Cap.	Comp. Motor Input	Sensible To Total Ratio (S/T)			Total Cool Cap.	Comp. Motor Input	Sensible To Total Ratio (S/T)		
				Dry Bulb					Dry Bulb					Dry Bulb					Dry Bulb		
cfm	kBtuh	kW	75°F	80°F	85°F	kBtuh	kW	75°F	80°F	85°F	kBtuh	kW	75°F	80°F	85°F	kBtuh	kW	75°F	80°F	85°F	
63°F	1280	45.4	2.77	0.72	0.86	1.00	42.1	3.12	0.73	0.88	1.00	38.5	3.53	0.74	0.92	1.00	34.9	4.02	0.76	0.96	1.00
	1600	48.1	2.78	0.78	0.95	1.00	44.7	3.14	0.79	0.98	1.00	41.1	3.55	0.82	1.00	1.00	37.5	4.04	0.85	1.00	1.00
	1920	50.5	2.79	0.84	1.00	1.00	47.2	3.15	0.86	1.00	1.00	43.7	3.58	0.89	1.00	1.00	40	4.07	0.93	1.00	1.00
67°F	1280	48.3	2.78	0.56	0.69	0.83	44.9	3.14	0.55	0.70	0.85	41.2	3.55	0.56	0.72	0.88	37.4	4.04	0.56	0.74	0.92
	1600	51.1	2.8	0.59	0.76	0.92	47.4	3.16	0.60	0.77	0.95	43.5	3.57	0.61	0.80	0.98	39.4	4.06	0.62	0.83	1.00
	1920	53.1	2.81	0.63	0.82	0.99	49.2	3.17	0.64	0.84	1.00	45.1	3.59	0.65	0.87	1.00	40.8	4.08	0.67	0.91	1.00
71°F	1280	51.4	2.8	0.41	0.54	0.67	47.8	3.16	0.40	0.55	0.68	44	3.58	0.39	0.55	0.70	40	4.07	0.38	0.56	0.72
	1600	54.2	2.81	0.43	0.59	0.74	50.2	3.17	0.42	0.59	0.75	46.3	3.59	0.42	0.60	0.78	42	4.09	0.41	0.61	0.81
	1920	56.1	2.83	0.45	0.63	0.80	52.1	3.19	0.45	0.64	0.82	47.6	3.6	0.44	0.65	0.85	43.3	4.1	0.44	0.67	0.89

4 TON HEATING HIGH EFFICIENCY KHB048H4

Indoor Coil Air Volume 70°F Dry Bulb cfm	Air Temperature Entering Outdoor Coil									
	65°F		45°F		25°F		5°F		-15°F	
	Total Heating Capacity	Comp. Motor Input	Total Heating Capacity	Comp. Motor Input	Total Heating Capacity	Comp. Motor Input	Total Heating Capacity	Comp. Motor Input	Total Heating Capacity	Comp. Motor Input
	kBtuh	kW	kBtuh	kW	kBtuh	kW	kBtuh	kW	kBtuh	kW
1280	57.0	3.22	42.5	2.99	27.4	2.76	17.6	2.43	8.8	1.83
1600	58.0	3.01	43.5	2.79	28.4	2.56	18.6	2.23	9.8	1.63
1920	58.8	2.89	44.3	2.67	29.2	2.44	19.4	2.11	10.6	1.51

NOTE – For Temperatures and Capacities not shown in tables, see bulletin – Cooling Unit Rating Table Correction Factor Data in Miscellaneous Engineering Data section.

5 TON COOLING HIGH EFFICIENCY KHB060H4 (1ST STAGE)

Entering Wet Bulb Temperature	Total Air Volume	Outdoor Air Temperature Entering Outdoor Coil																							
		65°F						75°F						85°F						95°F					
		Total Cool Cap.	Comp. Motor Input	Sensible To Total Ratio (S/T)			Total Cool Cap.	Comp. Motor Input	Sensible To Total Ratio (S/T)			Total Cool Cap.	Comp. Motor Input	Sensible To Total Ratio (S/T)			Total Cool Cap.	Comp. Motor Input	Sensible To Total Ratio (S/T)						
				Dry Bulb					Dry Bulb					Dry Bulb					Dry Bulb						
cfm	kBtuh	kW	75°F	80°F	85°F	kBtuh	kW	75°F	80°F	85°F	kBtuh	kW	75°F	80°F	85°F	kBtuh	kW	75°F	80°F	85°F					
63°F	1080	46.1	1.83	0.70	0.82	0.95	44.4	2.14	0.70	0.83	0.97	42.4	2.48	0.72	0.86	0.99	40.1	2.87	0.74	0.89	1.00				
	1350	48.7	1.81	0.74	0.89	1.00	46.9	2.12	0.75	0.91	1.00	44.8	2.47	0.77	0.94	1.00	42.3	2.86	0.80	0.97	1.00				
	1620	50.8	1.80	0.79	0.96	1.00	48.9	2.11	0.80	0.98	1.00	46.6	2.45	0.82	1.00	1.00	44.3	2.84	0.86	1.00	1.00				
67°F	1080	49.0	1.81	0.55	0.67	0.78	47.3	2.12	0.56	0.68	0.80	45.1	2.46	0.57	0.69	0.82	42.8	2.85	0.59	0.71	0.84				
	1350	51.8	1.79	0.58	0.72	0.85	49.8	2.10	0.59	0.73	0.87	47.6	2.45	0.60	0.75	0.90	45.0	2.84	0.62	0.77	0.93				
	1620	53.9	1.78	0.61	0.76	0.92	51.8	2.09	0.62	0.78	0.94	49.2	2.44	0.63	0.80	0.97	46.5	2.83	0.65	0.83	1.00				
71°F	1080	52.1	1.79	0.43	0.53	0.64	50.3	2.10	0.43	0.54	0.65	48.1	2.45	0.43	0.55	0.67	45.6	2.84	0.44	0.57	0.68				
	1350	55.0	1.77	0.44	0.57	0.69	52.9	2.08	0.44	0.57	0.70	50.5	2.43	0.45	0.58	0.72	47.7	2.82	0.46	0.60	0.74				
	1620	57.1	1.76	0.45	0.60	0.74	54.9	2.07	0.46	0.61	0.75	52.3	2.42	0.46	0.62	0.77	49.3	2.82	0.47	0.63	0.80				

5 TON COOLING HIGH EFFICIENCY KHB060H4 (2ND STAGE)

Entering Wet Bulb Temperature	Total Air Volume	Outdoor Air Temperature Entering Outdoor Coil																							
		85°F						95°F						105°F						115°F					
		Total Cool Cap.	Comp. Motor Input	Sensible To Total Ratio (S/T)			Total Cool Cap.	Comp. Motor Input	Sensible To Total Ratio (S/T)			Total Cool Cap.	Comp. Motor Input	Sensible To Total Ratio (S/T)			Total Cool Cap.	Comp. Motor Input	Sensible To Total Ratio (S/T)						
				Dry Bulb					Dry Bulb					Dry Bulb					Dry Bulb						
cfm	kBtuh	kW	75°F	80°F	85°F	kBtuh	kW	75°F	80°F	85°F	kBtuh	kW	75°F	80°F	85°F	kBtuh	kW	75°F	80°F	85°F					
63°F	1600	58.5	3.50	0.71	0.86	1.00	54.4	3.93	0.71	0.88	1.00	50.0	4.41	0.73	0.91	1.00	45.4	4.98	0.75	0.95	1.00				
	2000	62.0	3.53	0.76	0.95	1.00	57.9	3.96	0.79	0.98	1.00	53.4	4.45	0.81	1.00	1.00	49.0	5.02	0.84	1.00	1.00				
	2400	65.2	3.56	0.83	1.00	1.00	61.2	3.99	0.85	1.00	1.00	56.9	4.49	0.88	1.00	1.00	52.3	5.06	0.92	1.00	1.00				
67°F	1600	62.9	3.54	0.55	0.68	0.82	58.6	3.97	0.54	0.69	0.84	54.2	4.46	0.55	0.71	0.87	49.1	5.02	0.55	0.73	0.91				
	2000	66.4	3.57	0.58	0.74	0.91	61.9	4.00	0.59	0.76	0.94	57.2	4.49	0.60	0.78	0.98	51.9	5.05	0.60	0.81	1.00				
	2400	69.1	3.60	0.62	0.81	0.99	64.4	4.02	0.63	0.83	1.00	59.3	4.51	0.63	0.85	1.00	54.0	5.08	0.65	0.90	1.00				
71°F	1600	67.5	3.58	0.40	0.53	0.66	63.2	4.01	0.40	0.53	0.67	58.5	4.50	0.39	0.54	0.68	53.3	5.06	0.38	0.54	0.70				
	2000	71.1	3.61	0.42	0.57	0.72	66.6	4.04	0.42	0.58	0.73	61.5	4.53	0.41	0.59	0.76	56.2	5.10	0.40	0.60	0.79				
	2400	73.8	3.64	0.44	0.61	0.78	68.9	4.06	0.44	0.62	0.80	63.6	4.56	0.43	0.64	0.83	58.1	5.13	0.43	0.64	0.87				

5 TON HEATING HIGH EFFICIENCY KHB060H4

Indoor Coil Air Volume 70°F Dry Bulb cfm	Air Temperature Entering Outdoor Coil														
	65°F			45°F			25°F			5°F			-15°F		
	Total Heating Capacity	Comp. Motor Input	Total Heating Capacity	Comp. Motor Input	Total Heating Capacity	Comp. Motor Input	Total Heating Capacity	Comp. Motor Input	Total Heating Capacity	Comp. Motor Input	Total Heating Capacity	Comp. Motor Input	Total Heating Capacity	Comp. Motor Input	
															kBtuh
1600	72.6	4.07	55.2	3.81	37.4	3.55	23.1	3.17	11.6	2.38					
2000	73.8	3.81	56.4	3.55	38.6	3.29	24.3	2.91	12.8	2.12					
2400	74.8	3.64	57.3	3.39	39.5	3.13	25.2	2.75	13.7	1.96					

BLOWER DATA**DIRECT DRIVE - STANDARD EFFICIENCY - 2 TON | 2.5 TON****BLOWER TABLE INCLUDES RESISTANCE FOR BASE UNIT ONLY WITH DRY INDOOR COIL AND AIR FILTERS IN PLACE.**

FOR ALL UNITS ADD:

1 - Any factory installed options air resistance (economizer, wet coil, etc.) See page 41.

2 - Any field installed accessories air resistance (electric heat, duct resistance, diffuser, etc.) See page 41.

External Static Pressure (in. w.g.)	Air Volume (cfm) at Various Blower Speeds					
	208 VOLTS			230 VOLTS		
	High	Medium	Low	High	Medium	Low
DOWNFLOW	KHB024S4D and KHB030S4D					
0.0	1199	928	838	1379	1085	877
0.1	1229	926	813	1409	1086	872
0.2	1206	928	782	1367	1094	850
0.3	1183	881	742	1350	1047	820
0.4	1159	843	686	1321	1009	783
0.5	1136	812	643	1282	981	762
0.6	1103	766	569	1242	921	705
0.7	1046	728	496	1195	888	625
0.8	953	648	432	1134	792	583
0.9	909	584	335	1037	738	492
1.0	783	465	247	926	592	411
HORIZONTAL	KHB024S4D and KHB030S4D					
0.0	1152	909	801	1325	1063	838
0.1	1152	893	770	1321	1048	826
0.2	1136	866	734	1288	1021	798
0.3	1104	826	697	1260	982	771
0.4	1072	787	643	1222	942	734
0.5	1041	747	589	1175	903	698
0.6	1009	707	534	1137	850	662
0.7	946	654	467	1081	797	588
0.8	861	588	396	1024	718	535
0.9	798	508	319	911	642	468
1.0	715	443	237	846	564	394

BLOWER DATA**DIRECT DRIVE - STANDARD EFFICIENCY - 3 TON****BLOWER TABLE INCLUDES RESISTANCE FOR BASE UNIT ONLY WITH DRY INDOOR COIL AND AIR FILTERS IN PLACE.**

FOR ALL UNITS ADD:

1 - Any factory installed options air resistance (economizer, wet coil, etc.) See page 41.

2 - Any field installed accessories air resistance (electric heat, duct resistance, diffuser, etc.) See page 41.

External Static Pressure (in. w.g.)	Air Volume (cfm) at Various Blower Speeds								
	208 VOLTS			230 VOLTS			460/575 VOLTS		
	High	Medium	Low	High	Medium	Low	High	Medium	Low
DOWNFLOW	KHB036S4D								
0.0	1938	1552	1119	2167	1772	1317	2136	1716	1212
0.1	1992	1586	1128	2167	1780	1315	2104	1728	1208
0.2	1915	1592	1137	2100	1792	1307	2052	1684	1197
0.3	1865	1536	1083	2043	1735	1266	1994	1647	1172
0.4	1813	1495	1033	1986	1678	1204	1918	1597	1134
0.5	1762	1444	976	1909	1621	1164	1861	1534	1096
0.6	1694	1391	899	1814	1535	1082	1765	1485	1059
0.7	1609	1331	817	1718	1478	1000	1689	1410	996
0.8	1471	1220	730	1603	1364	918	1613	1335	920
0.9	1368	1066	522	1488	1250	755	1498	1235	848
1.0	1108	869	402	1259	1021	640	1345	1036	763
HORIZONTAL	KHB036S4D								
0.0	1862	1520	1070	2082	1736	1259	2085	1745	1247
0.1	1867	1530	1069	2031	1717	1246	2070	1744	1257
0.2	1804	1485	1067	1978	1672	1227	2016	1690	1225
0.3	1741	1440	1018	1907	1627	1190	1944	1643	1192
0.4	1677	1396	968	1837	1567	1128	1890	1596	1160
0.5	1614	1329	894	1749	1492	1066	1800	1533	1111
0.6	1550	1284	844	1660	1417	1016	1727	1455	1062
0.7	1455	1195	769	1554	1327	941	1655	1377	996
0.8	1329	1106	670	1448	1237	842	1511	1283	865
0.9	1202	927	496	1307	1087	718	1403	1190	784
1.0	1012	828	385	1150	973	613	1222	1002	670

BLOWER DATA**DIRECT DRIVE - STANDARD EFFICIENCY - 4 TON****BLOWER TABLE INCLUDES RESISTANCE FOR BASE UNIT ONLY WITH DRY INDOOR COIL AND AIR FILTERS IN PLACE.**

FOR ALL UNITS ADD:

1 - Any factory installed options air resistance (economizer, wet coil, etc.) See page 41.

2 - Any field installed accessories air resistance (electric heat, duct resistance, diffuser, etc.) See page 41.

External Static Pressure (in. w.g.)	Air Volume (cfm) at Various Blower Speeds								
	208 VOLTS			230 VOLTS			460/575 VOLTS		
	High	Medium	Low	High	Medium	Low	High	Medium	Low
DOWNFLOW									
	KHB048S4D								
0.0	1951	1542	1098	2139	1542	1271	2139	1542	1271
0.1	1918	1526	1081	2105	1526	1261	2105	1526	1261
0.2	1877	1508	1062	2054	1508	1238	2054	1508	1238
0.3	1814	1448	1026	1986	1448	1196	1986	1448	1196
0.4	1752	1407	990	1918	1407	1154	1918	1407	1154
0.5	1689	1347	936	1826	1347	1099	1826	1347	1099
0.6	1605	1286	864	1735	1286	1043	1735	1286	1043
0.7	1500	1206	774	1644	1206	932	1644	1206	932
0.8	1375	1085	---	1461	1085	---	1461	1085	---
0.9	1202	---	---	---	---	---	---	---	---
1.0	---	---	---	---	---	---	---	---	---
HORIZONTAL									
	KHB048S4D								
0.0	1901	1506	1079	2072	1718	1249	2072	1718	1249
0.1	1855	1478	1069	2026	1686	1238	2026	1686	1238
0.2	1800	1458	1049	1969	1644	1206	1969	1644	1206
0.3	1744	1396	1012	1908	1601	1161	1908	1601	1161
0.4	1687	1346	936	1847	1530	1115	1847	1530	1115
0.5	1630	1296	886	1755	1460	1047	1755	1460	1047
0.6	1546	1222	811	1663	1403	1002	1663	1403	1002
0.7	1461	1147	735	1572	1290	910	1572	1290	910
0.8	1347	1073	660	1419	1205	820	1419	1205	820
0.9	1178	874	560	1296	1006	683	1296	1006	683
1.0	954	624	358	1129	---	496	1129	---	496

BLOWER DATA**DIRECT DRIVE - HIGH EFFICIENCY - 2 TON****BLOWER TABLE INCLUDES RESISTANCE FOR BASE UNIT ONLY WITH DRY INDOOR COIL AND AIR FILTERS IN PLACE.**

FOR ALL UNITS ADD:

1 - Any factory installed options air resistance (economizer, wet coil, etc.) See page 41.

2 - Any field installed accessories air resistance (electric heat, duct resistance, diffuser, etc.) See page 41.

External Static Pressure in. w.g.	Air Volume at Specific Blower Taps (cfm)				
	Tap 1	Tap 2	Tap 3	Tap 4	Tap 5
DOWNFLOW					KHB024H4E
0.0	635	728	918	1121	1336
0.1	547	689	861	1071	1290
0.2	433	607	806	1031	1253
0.3	371	528	749	986	1212
0.4	280	460	677	927	1166
0.5	217	380	605	868	1120
0.6	---	---	548	819	1071
0.7	---	---	491	773	1029
0.8	---	---	442	714	983
0.9	---	---	393	653	929
1.0	---	---	---	604	879
HORIZONTAL					KHB024H4E
0.0	602	715	908	1096	1302
0.1	509	663	852	1057	1263
0.2	413	588	793	1007	1227
0.3	340	507	736	964	1189
0.4	266	438	679	918	1142
0.5	220	355	620	864	1100
0.6	---	---	560	809	1061
0.7	---	---	500	752	1015
0.8	---	---	444	706	964
0.9	---	---	390	661	913
1.0	---	---	352	612	872

BLOWER DATA**DIRECT DRIVE - HIGH EFFICIENCY - 3 TON****BLOWER TABLE INCLUDES RESISTANCE FOR BASE UNIT ONLY WITH DRY INDOOR COIL AND AIR FILTERS IN PLACE.**

FOR ALL UNITS ADD:

1 - Any factory installed options air resistance (economizer, wet coil, etc.) See page 41.

2 - Any field installed accessories air resistance (electric heat, duct resistance, diffuser, etc.) See page 41.

External Static Pressure in. w.g.	Air Volume at Specific Blower Taps (cfm)				
	Tap 1	Tap 2	Tap 3	Tap 4	Tap 5
DOWNFLOW	KHB036H4E				
0.0	893	1035	1375	1600	1840
0.1	838	965	1330	1574	1780
0.2	768	895	1277	1543	1748
0.3	705	800	1253	1505	1712
0.4	645	750	1200	1473	1677
0.5	575	690	1150	1435	1638
0.6	---	---	1095	1390	1608
0.7	---	---	1052	1345	1577
0.8	---	---	1004	1302	1528
0.9	---	---	950	1260	1491
1.0	---	---	900	1218	1455
HORIZONTAL	KHB036H4E				
0.0	900	1045	1379	1599	1810
0.1	828	970	1305	1549	1749
0.2	777	900	1264	1504	1718
0.3	702	800	1216	1479	1677
0.4	635	750	1173	1434	1649
0.5	553	685	1131	1399	1622
0.6	---	---	1078	1359	1577
0.7	---	---	1038	1315	1544
0.8	---	---	986	1280	1509
0.9	---	---	933	1236	1471
1.0	---	---	885	1196	1438

BLOWER DATA**DIRECT DRIVE - HIGH EFFICIENCY - 4 TON****BLOWER TABLE INCLUDES RESISTANCE FOR BASE UNIT ONLY WITH DRY INDOOR COIL AND AIR FILTERS IN PLACE.**

FOR ALL UNITS ADD:

1 - Any factory installed options air resistance (economizer, wet coil, etc.) See page 41.

2 - Any field installed accessories air resistance (electric heat, duct resistance, diffuser, etc.) See page 41.

External Static Pressure in. w.g.	Air Volume at Specific Blower Taps (cfm)				
	Tap 1	Tap 2	Tap 3	Tap 4	Tap 5
DOWNFLOW					KHB048H4E
0.0	1225	1310	1561	2015	2168
0.1	1167	1254	1514	1995	2143
0.2	1112	1203	1473	1977	2126
0.3	1052	1145	1424	1942	2097
0.4	1000	1098	1387	1917	2078
0.5	939	1040	1343	1888	2049
0.6	894	996	1300	1854	2020
0.7	840	941	1250	1819	1991
0.8	780	883	1201	1787	1952
0.9	734	839	1159	1749	1914
1.0	681	784	1115	1704	1856
HORIZONTAL					KHB048H4E
0.0	1185	1265	1504	1983	2120
0.1	1130	1213	1467	1957	2098
0.2	1085	1171	1432	1932	2077
0.3	1035	1125	1395	1906	2054
0.4	978	1069	1347	1870	2023
0.5	929	1023	1304	1841	1992
0.6	880	977	1267	1811	1962
0.7	822	920	1224	1776	1931
0.8	764	863	1175	1740	1900
0.9	718	820	1133	1710	1869
1.0	549	712	1096	1652	1772

BLOWER DATA**DIRECT DRIVE - HIGH EFFICIENCY - 5 TON****BLOWER TABLE INCLUDES RESISTANCE FOR BASE UNIT ONLY WITH DRY INDOOR COIL AND AIR FILTERS IN PLACE.**

FOR ALL UNITS ADD:

1 - Any factory installed options air resistance (economizer, wet coil, etc.) See page 41.

2 - Any field installed accessories air resistance (electric heat, duct resistance, diffuser, etc.) See page 41.

External Static Pressure in. w.g.	Air Volume at Specific Blower Taps (cfm)					
	Tap 1	Tap 2	Tap 3	Tap 4	Tap 5	
DOWNFLOW						KHB060H4E
0.0	1351	1405	1801	1982	2339	
0.1	1303	1359	1769	1956	2310	
0.2	1254	1314	1736	1928	2281	
0.3	1206	1268	1703	1900	2253	
0.4	1158	1222	1669	1870	2224	
0.5	1109	1177	1634	1838	2195	
0.6	1061	1131	1598	1806	2166	
0.7	1012	1085	1561	1772	2137	
0.8	964	1040	1524	1736	2108	
0.9	915	994	1486	1700	2080	
1.0	867	949	1446	1662	2051	
HORIZONTAL						KHB60H4E
0.0	1329	1353	1728	1886	2206	
0.1	1284	1320	1708	1872	2189	
0.2	1239	1285	1685	1859	2174	
0.3	1193	1258	1661	1832	2157	
0.4	1147	1218	1636	1814	2135	
0.5	1100	1178	1608	1796	2118	
0.6	1052	1125	1579	1770	2102	
0.7	1004	1085	1548	1743	2080	
0.8	955	1044	1516	1716	2058	
0.9	906	991	1481	1689	2036	
1.0	856	938	1445	1654	2020	

BLOWER DATA

BELT DRIVE - 3 TON

BLOWER TABLE INCLUDES RESISTANCE FOR BASE UNIT ONLY WITH DRY INDOOR COIL AND AIR FILTERS IN PLACE.

FOR ALL UNITS ADD:

1 - Any factory installed options air resistance (economizer, wet coil, etc.).

2 - Any field installed accessories air resistance (electric heat, duct resistance, diffuser, etc.).

See page 40 for blower motors and drives and page 41 for wet coil and options/accessory air resistance data.

DOWNFLOW

KHB036S4B - KHB036H4T

Air Volume cfm	External Static - in. w.g.															
	0.10		0.20		0.30		0.40		0.50		0.60		0.70		0.80	
	RPM	BHP	RPM	BHP	RPM	BHP	RPM	BHP	RPM	BHP	RPM	BHP	RPM	BHP	RPM	BHP
700	447	0.09	517	0.12	589	0.15	663	0.17	739	0.19	815	0.20	883	0.23	938	0.25
800	465	0.10	534	0.14	605	0.17	678	0.19	753	0.21	825	0.23	890	0.25	946	0.27
900	486	0.12	554	0.16	623	0.20	695	0.22	767	0.23	836	0.25	897	0.28	953	0.30
1000	508	0.15	576	0.19	643	0.22	713	0.24	783	0.26	848	0.28	907	0.30	961	0.33
1100	533	0.18	599	0.22	665	0.25	733	0.27	800	0.28	863	0.31	919	0.34	971	0.36
1200	560	0.21	625	0.25	689	0.28	755	0.30	820	0.32	879	0.34	932	0.37	983	0.40
1300	591	0.24	654	0.28	716	0.31	779	0.33	841	0.35	897	0.38	948	0.41	996	0.44
1400	631	0.26	690	0.30	748	0.34	807	0.36	864	0.39	916	0.42	964	0.46	1011	0.49
1500	676	0.28	729	0.33	782	0.36	835	0.40	887	0.43	935	0.47	981	0.50	1028	0.54

Air Volume cfm	External Static - in. w.g.															
	0.90		1.00		1.10		1.20		1.30		1.40		1.50		1.60	
	RPM	BHP	RPM	BHP	RPM	BHP	RPM	BHP	RPM	BHP	RPM	BHP	RPM	BHP	RPM	BHP
700	988	0.27	1039	0.29	1088	0.31	---	---	---	---	---	---	---	---	---	---
800	996	0.30	1047	0.32	1098	0.34	1144	0.36	1185	0.39	1224	0.42	---	---	---	---
900	1004	0.33	1055	0.35	1106	0.37	1152	0.40	1193	0.43	1232	0.46	1269	0.49	1305	0.52
1000	1011	0.36	1062	0.38	1111	0.41	1157	0.43	1199	0.47	1238	0.50	1276	0.53	1311	0.56
1100	1020	0.39	1070	0.41	1118	0.44	1163	0.47	1206	0.51	1245	0.54	1282	0.58	1318	0.61
1200	1031	0.43	1079	0.45	1127	0.48	1171	0.52	1213	0.55	1252	0.59	1289	0.62	1324	0.66
1300	1044	0.47	1091	0.49	1137	0.53	1181	0.56	1221	0.60	1259	0.64	1296	0.68	1330	0.71
1400	1058	0.51	1105	0.54	1150	0.57	1191	0.61	1231	0.65	1268	0.69	1303	0.73	1337	0.77
1500	1074	0.56	1120	0.59	1163	0.63	1203	0.67	1241	0.71	1277	0.75	1312	0.79	1345	0.82

BLOWER DATA

BELT DRIVE - 3 TON

BLOWER TABLE INCLUDES RESISTANCE FOR BASE UNIT ONLY WITH DRY INDOOR COIL AND AIR FILTERS IN PLACE.

FOR ALL UNITS ADD:

1 - Any factory installed options air resistance (economizer, wet coil, etc.).

2 - Any field installed accessories air resistance (electric heat, duct resistance, diffuser, etc.).

See page 40 for blower motors and drives and page 41 for wet coil and options/accessory air resistance data.

HORIZONTAL

KHB036S4B - KHB036H4T

Air Volume cfm	External Static - in. w.g.															
	0.10		0.20		0.30		0.40		0.50		0.60		0.70		0.80	
	RPM	BHP	RPM	BHP	RPM	BHP	RPM	BHP	RPM	BHP	RPM	BHP	RPM	BHP	RPM	BHP
700	445	0.08	516	0.11	591	0.13	670	0.15	753	0.16	820	0.19	870	0.22	918	0.24
800	463	0.09	534	0.12	608	0.14	685	0.16	766	0.18	830	0.21	878	0.24	926	0.27
900	485	0.11	554	0.14	627	0.16	703	0.18	780	0.21	841	0.23	888	0.27	935	0.30
1000	509	0.13	578	0.16	649	0.19	722	0.21	796	0.23	854	0.26	900	0.29	947	0.33
1100	537	0.16	605	0.19	674	0.21	744	0.24	813	0.26	868	0.29	913	0.33	959	0.36
1200	567	0.19	633	0.22	700	0.24	768	0.27	833	0.30	884	0.33	928	0.37	974	0.40
1300	599	0.22	664	0.25	729	0.28	793	0.30	853	0.33	902	0.37	945	0.41	990	0.44
1400	634	0.26	697	0.29	758	0.31	819	0.34	875	0.38	921	0.42	964	0.46	1008	0.49
1500	669	0.30	730	0.33	789	0.36	846	0.39	897	0.42	941	0.47	983	0.51	1028	0.54

Air Volume cfm	External Static - in. w.g.															
	0.90		1.00		1.10		1.20		1.30		1.40		1.50		1.60	
	RPM	BHP	RPM	BHP	RPM	BHP	RPM	BHP	RPM	BHP	RPM	BHP	RPM	BHP	RPM	BHP
700	969	0.27	1021	0.29	1071	0.32	---	---	---	---	---	---	---	---	---	---
800	977	0.29	1030	0.32	1082	0.34	1128	0.37	1169	0.40	1205	0.42	---	---	---	---
900	986	0.32	1039	0.35	1090	0.37	1137	0.40	1177	0.43	1214	0.46	1248	0.49	1280	0.51
1000	997	0.35	1048	0.38	1098	0.41	114	0.44	1184	0.47	1221	0.50	1255	0.53	1287	0.56
1100	1008	0.39	1059	0.41	1107	0.44	1150	0.47	1191	0.51	1228	0.54	1263	0.57	1295	0.60
1200	1022	0.43	1071	0.45	1117	0.48	1160	0.52	1200	0.55	1237	0.59	1271	0.62	1303	0.66
1300	1037	0.47	1058	0.50	1130	0.53	1171	0.57	1210	0.60	1246	0.64	1280	0.68	1312	0.71
1400	1054	0.52	1100	0.54	1144	0.58	1183	0.62	1221	0.66	1256	0.70	1290	0.73	1321	0.77
1500	1073	0.57	1117	0.60	1159	0.64	1197	0.67	1234	0.71	1268	0.75	1301	0.79	1332	0.83

BLOWER DATA

BELT DRIVE -4 TON

BLOWER TABLE INCLUDES RESISTANCE FOR BASE UNIT ONLY WITH DRY INDOOR COIL AND AIR FILTERS IN PLACE.

FOR ALL UNITS ADD:

1 - Any factory installed options air resistance (economizer, wet coil, etc.).

2 - Any field installed accessories air resistance (electric heat, duct resistance, diffuser, etc.).

See page 40 for blower motors and drives and page 41 for wet coil and options/accessory air resistance data.

DOWNFLOW

KHB048S4B - KHB048H4T

Air Volume cfm	External Static - in. w.g.															
	0.10		0.20		0.30		0.40		0.50		0.60		0.70		0.80	
	RPM	BHP	RPM	BHP	RPM	BHP	RPM	BHP	RPM	BHP	RPM	BHP	RPM	BHP	RPM	BHP
900	466	0.10	525	0.14	586	0.17	646	0.20	729	0.20	821	0.19	899	0.20	953	0.23
1000	484	0.12	543	0.16	603	0.19	664	0.22	745	0.23	834	0.23	908	0.24	959	0.26
1100	505	0.15	563	0.18	622	0.22	682	0.25	762	0.26	847	0.26	917	0.27	966	0.30
1200	527	0.18	584	0.21	643	0.25	702	0.28	779	0.30	860	0.30	927	0.31	973	0.34
1300	550	0.21	607	0.25	664	0.29	722	0.32	797	0.33	875	0.34	937	0.35	981	0.38
1400	574	0.25	630	0.29	687	0.32	744	0.35	817	0.37	890	0.38	949	0.39	991	0.42
1500	603	0.28	659	0.32	714	0.36	770	0.39	839	0.41	907	0.42	962	0.44	1002	0.47
1600	651	0.29	703	0.33	754	0.37	806	0.41	867	0.43	927	0.45	976	0.48	1014	0.51
1700	708	0.30	754	0.34	800	0.38	846	0.42	898	0.46	949	0.49	992	0.53	1028	0.57
1800	764	0.31	804	0.36	844	0.40	884	0.45	927	0.49	970	0.54	1008	0.58	1044	0.63
1900	812	0.34	847	0.39	881	0.44	916	0.49	953	0.54	990	0.59	1025	0.64	1061	0.69
2000	857	0.42	889	0.47	920	0.52	952	0.57	986	0.62	1020	0.68	1055	0.73	1091	0.77

Air Volume cfm	External Static - in. w.g.															
	0.90		1.00		1.10		1.20		1.30		1.40		1.50		1.60	
	RPM	BHP	RPM	BHP	RPM	BHP	RPM	BHP	RPM	BHP	RPM	BHP	RPM	BHP	RPM	BHP
900	---	---	---	---	---	---	---	---	---	---	---	---	---	---	---	---
1000	996	0.31	1034	0.35	---	---	---	---	---	---	---	---	---	---	---	---
1100	1001	0.34	1040	0.38	1083	0.42	1128	0.46	1176	0.49	---	---	---	---	---	---
1200	1008	0.38	1047	0.42	1089	0.46	1133	0.49	1180	0.53	1224	0.56	1261	0.60	---	---
1300	1017	0.42	1055	0.46	1097	0.50	1139	0.53	1184	0.57	1228	0.60	1264	0.63	1295	0.67
1400	1026	0.46	1065	0.50	1106	0.54	1147	0.57	1191	0.61	1233	0.64	1269	0.68	1300	0.71
1500	1038	0.51	1076	0.55	1117	0.59	1157	0.62	1199	0.65	1240	0.69	1275	0.72	1305	0.76
1600	1050	0.56	1089	0.60	1129	0.64	1168	0.67	1209	0.71	1249	0.74	1282	0.78	1312	0.82
1700	1065	0.61	1103	0.65	1142	0.69	1181	0.73	1221	0.76	1259	0.80	1292	0.83	1320	0.88
1800	1081	0.67	1118	0.71	1156	0.75	1194	0.79	1234	0.82	1271	0.86	1302	0.90	1330	0.94
1900	1098	0.73	1135	0.77	1172	0.81	1209	0.85	1248	0.88	1284	0.92	1314	0.97	1341	1.01
2000	1128	0.82	1164	0.86	1201	0.89	1239	0.93	1276	0.97	1310	1.01	1336	1.06	1362	1.10

BLOWER DATA

BELT DRIVE - 4 TON

BLOWER TABLE INCLUDES RESISTANCE FOR BASE UNIT ONLY WITH DRY INDOOR COIL AND AIR FILTERS IN PLACE.

FOR ALL UNITS ADD:

1 - Any factory installed options air resistance (economizer, wet coil, etc.).

2 - Any field installed accessories air resistance (electric heat, duct resistance, diffuser, etc.).

See page 40 for blower motors and drives and page 41 for wet coil and options/accessory air resistance data.

HORIZONTAL

KHB048S4B - KHB048H4T

Air Volume cfm	External Static - in. w.g.															
	0.10		0.20		0.30		0.40		0.50		0.60		0.70		0.80	
	RPM	BHP	RPM	BHP	RPM	BHP	RPM	BHP	RPM	BHP	RPM	BHP	RPM	BHP	RPM	BHP
900	464	0.10	514	0.13	576	0.15	644	0.17	728	0.18	817	0.19	893	0.21	951	0.24
1000	482	0.12	533	0.15	595	0.17	662	0.19	744	0.21	829	0.22	902	0.24	957	0.27
1100	504	0.14	556	0.17	617	0.20	683	0.22	762	0.24	843	0.25	912	0.28	965	0.31
1200	528	0.17	581	0.20	641	0.23	706	0.25	782	0.27	859	0.29	924	0.31	974	0.34
1300	556	0.21	609	0.24	669	0.26	731	0.29	804	0.31	877	0.33	938	0.35	985	0.38
1400	592	0.24	645	0.27	702	0.30	763	0.32	830	0.35	898	0.37	953	0.39	997	0.43
1500	641	0.26	692	0.29	746	0.33	801	0.36	862	0.38	921	0.41	970	0.44	1011	0.48
1600	696	0.28	743	0.32	792	0.35	842	0.39	894	0.42	945	0.45	988	0.49	1027	0.53
1700	750	0.31	792	0.35	836	0.39	880	0.43	924	0.47	968	0.51	1007	0.55	1043	0.59
1800	799	0.35	837	0.39	875	0.43	913	0.48	952	0.52	990	0.56	1026	0.61	1061	0.65
1900	840	0.40	873	0.45	907	0.49	941	0.54	976	0.58	1011	0.63	1045	0.67	1080	0.72
2000	883	0.48	913	0.53	944	0.57	976	0.62	1009	0.67	1043	0.71	1078	0.76	1112	0.8

Air Volume cfm	External Static - in. w.g.															
	0.90		1.00		1.10		1.20		1.30		1.40		1.50		1.60	
	RPM	BHP	RPM	BHP	RPM	BHP	RPM	BHP	RPM	BHP	RPM	BHP	RPM	BHP	RPM	BHP
900	995	0.28	1034	0.31	1077	0.35	1121	0.38	---	---	---	---	---	---	---	---
1000	999	0.31	1038	0.34	1081	0.38	1124	0.41	1168	0.44	1211	0.47	---	---	---	---
1100	1006	0.34	1044	0.38	1086	0.41	1129	0.44	1171	0.47	1213	0.50	1253	0.53	1293	0.56
1200	1014	0.38	1052	0.42	1093	0.45	1135	0.48	1176	0.51	1217	0.54	1257	0.58	1296	0.61
1300	1023	0.42	1061	0.46	1102	0.50	1143	0.53	1184	0.56	1224	0.59	1263	0.62	1302	0.66
1400	1035	0.47	1073	0.51	1112	0.54	1153	0.57	1193	0.61	1232	0.64	1271	0.67	1309	0.71
1500	1048	0.52	1086	0.56	1125	0.59	1164	0.63	1204	0.66	1243	0.69	1280	0.73	1317	0.77
1600	1063	0.57	1100	0.61	1139	0.65	1178	0.68	1216	0.71	1254	0.75	1291	0.79	1326	0.83
1700	1079	0.63	1116	0.67	1154	0.71	1192	0.74	1230	0.78	1267	0.81	1302	0.85	1337	0.89
1800	1097	0.69	1133	0.73	1171	0.77	1209	0.80	1246	0.84	1281	0.88	1315	0.92	1349	0.96
1900	1116	0.76	1152	0.80	1189	0.84	1226	0.87	1262	0.91	1296	0.95	1329	0.99	1361	1.03
2000	1148	0.84	1183	0.88	1220	0.92	1257	0.96	1291	1.00	1323	1.04	1354	1.08	1385	1.12

BLOWER DATA

BELT DRIVE - 5 TON

BLOWER TABLE INCLUDES RESISTANCE FOR BASE UNIT ONLY WITH DRY INDOOR COIL AND AIR FILTERS IN PLACE.

FOR ALL UNITS ADD:

1 - Any factory installed options air resistance (economizer, wet coil, etc.).

2 - Any field installed accessories air resistance (electric heat, duct resistance, diffuser, etc.).

See page 40 for blower motors and drives and page 41 for wet coil and options/accessory air resistance data.

DOWNFLOW

KHB060S4B - KHB060H4T

Air Volume cfm	External Static - in. w.g.															
	0.10		0.20		0.30		0.40		0.50		0.60		0.70		0.80	
	RPM	BHP	RPM	BHP	RPM	BHP	RPM	BHP	RPM	BHP	RPM	BHP	RPM	BHP	RPM	BHP
1100	512	0.15	571	0.19	630	0.23	690	0.26	770	0.26	854	0.26	922	0.27	970	0.30
1200	535	0.18	593	0.22	651	0.26	710	0.30	788	0.30	868	0.30	933	0.31	978	0.34
1300	559	0.22	616	0.26	674	0.29	732	0.34	807	0.34	883	0.34	944	0.35	987	0.38
1400	584	0.26	641	0.29	698	0.33	755	0.37	827	0.37	899	0.38	956	0.40	997	0.43
1500	615	0.29	671	0.33	726	0.36	782	0.41	850	0.41	917	0.42	970	0.44	1009	0.47
1600	665	0.30	716	0.34	768	0.38	819	0.44	879	0.44	937	0.46	985	0.49	1022	0.52
1700	723	0.31	768	0.35	814	0.39	860	0.47	910	0.47	959	0.50	1001	0.54	1037	0.58
1800	779	0.32	818	0.37	857	0.41	897	0.50	939	0.50	980	0.55	1018	0.59	1054	0.64
1900	826	0.36	859	0.41	894	0.45	928	0.56	964	0.56	1000	0.61	1036	0.66	1072	0.70
2000	857	0.42	889	0.47	920	0.52	952	0.62	986	0.62	1020	0.68	1055	0.73	1091	0.77
2100	878	0.49	909	0.54	940	0.59	973	0.70	1006	0.70	1041	0.75	1076	0.80	1112	0.85
2200	897	0.55	929	0.61	961	0.66	994	0.78	1028	0.78	1063	0.83	1099	0.89	1134	0.93
2300	918	0.62	950	0.68	983	0.74	1017	0.86	1052	0.86	1087	0.92	1122	0.97	1157	1.02
2400	941	0.70	974	0.77	1008	0.83	1042	0.96	1077	0.96	1111	1.01	1146	1.06	1181	1.11

Air Volume cfm	External Static - in. w.g.															
	0.90		1.00		1.10		1.20		1.30		1.40		1.50		1.60	
	RPM	BHP	RPM	BHP	RPM	BHP	RPM	BHP	RPM	BHP	RPM	BHP	RPM	BHP	RPM	BHP
1100	1006	0.35	1045	0.39	1089	0.43	1134	0.46	---	---	---	---	---	---	---	---
1200	1013	0.38	1053	0.42	1095	0.46	1139	0.50	1186	0.53	1230	0.57	1266	0.60	---	---
1300	1022	0.42	1062	0.46	1104	0.50	1146	0.54	1192	0.57	1234	0.60	1269	0.64	1301	0.68
1400	1033	0.47	1072	0.51	1114	0.55	1155	0.58	1199	0.61	1240	0.65	1275	0.68	1305	0.72
1500	1045	0.52	1085	0.56	1125	0.60	1165	0.63	1208	0.66	1248	0.69	1281	0.73	1311	0.77
1600	1059	0.57	1098	0.61	1138	0.65	1177	0.68	1218	0.71	1257	0.75	1290	0.79	1319	0.83
1700	1074	0.62	1113	0.66	1152	0.70	1190	0.74	1231	0.77	1268	0.80	1299	0.84	1328	0.89
1800	1091	0.68	1129	0.72	1167	0.76	1205	0.80	1244	0.83	1280	0.87	1310	0.91	1338	0.95
1900	1109	0.75	1146	0.79	1183	0.82	1221	0.86	1260	0.90	1294	0.94	1323	0.98	1349	1.02
2000	1128	0.82	1164	0.86	1201	0.89	1239	0.93	1276	0.97	1310	1.01	1336	1.06	1362	1.10
2100	1148	0.89	1185	0.93	1221	0.97	1258	1.01	1294	1.05	1325	1.09	1351	1.14	1376	1.19
2200	1170	0.97	1206	1.01	1242	1.05	1277	1.09	1311	1.14	1341	1.18	1365	1.23	1390	1.28
2300	1193	1.06	1228	1.09	1262	1.14	1295	1.19	1327	1.24	1355	1.29	1380	1.33	1406	1.37
2400	1216	1.15	1250	1.19	1282	1.24	1313	1.30	1343	1.36	1371	1.40	1396	1.44	1423	1.48

BLOWER DATA

BELT DRIVE - 5 TON

BLOWER TABLE INCLUDES RESISTANCE FOR BASE UNIT ONLY WITH DRY INDOOR COIL AND AIR FILTERS IN PLACE.

FOR ALL UNITS ADD:

1 - Any factory installed options air resistance (economizer, wet coil, etc.).

2 - Any field installed accessories air resistance (electric heat, duct resistance, diffuser, etc.).

See page 40 for blower motors and drives and page 41 for wet coil and options/accessory air resistance data.

HORIZONTAL

KHB060S4B - KHB060H4T

Air Volume cfm	External Static - in. w.g.															
	0.10		0.20		0.30		0.40		0.50		0.60		0.70		0.80	
	RPM	BHP	RPM	BHP	RPM	BHP	RPM	BHP	RPM	BHP	RPM	BHP	RPM	BHP	RPM	BHP
1100	509	0.15	562	0.18	624	0.20	691	0.22	771	0.24	852	0.25	919	0.28	970	0.31
1200	535	0.18	589	0.21	650	0.23	715	0.25	792	0.27	869	0.29	932	0.32	980	0.35
1300	564	0.21	618	0.24	678	0.27	741	0.29	815	0.31	887	0.33	946	0.36	991	0.39
1400	604	0.24	657	0.27	715	0.30	775	0.33	842	0.35	908	0.37	962	0.40	1004	0.43
1500	656	0.26	706	0.30	760	0.33	814	0.36	874	0.39	931	0.41	979	0.45	1019	0.48
1600	712	0.29	758	0.32	807	0.36	855	0.39	906	0.43	955	0.46	997	0.50	1035	0.54
1700	766	0.32	808	0.36	850	0.40	892	0.44	936	0.47	978	0.51	1016	0.56	1052	0.60
1800	814	0.36	851	0.40	888	0.44	925	0.49	963	0.53	1000	0.57	1035	0.62	1071	0.66
1900	853	0.41	886	0.46	919	0.50	952	0.55	986	0.60	1021	0.64	1056	0.69	1091	0.73
2000	883	0.48	913	0.53	944	0.57	976	0.62	1009	0.67	1043	0.71	1078	0.76	1112	0.80
2100	906	0.56	936	0.60	967	0.65	999	0.70	1033	0.75	1067	0.79	1101	0.84	1135	0.88
2200	930	0.64	960	0.68	991	0.73	1024	0.78	1058	0.83	1092	0.88	1126	0.92	1160	0.96
2300	954	0.72	985	0.77	1017	0.82	1051	0.87	1085	0.92	1119	0.96	1152	1.00	1186	1.04
2400	981	0.81	1013	0.86	1046	0.91	1079	0.96	1113	1.00	1180	1.05	1180	1.09	1213	1.13

Air Volume cfm	External Static - in. w.g.															
	0.90		1.00		1.10		1.20		1.30		1.40		1.50		1.60	
	RPM	BHP	RPM	BHP	RPM	BHP	RPM	BHP	RPM	BHP	RPM	BHP	RPM	BHP	RPM	BHP
1100	1010	35.00	1049	0.38	1091	0.42	1134	0.45	1176	0.78	1218	0.51	1258	0.54	1297	0.57
1200	1019	0.38	1058	0.42	1099	0.46	1141	0.49	1182	0.52	1223	0.55	1263	0.58	1302	0.61
1300	1030	0.43	1068	0.47	1108	0.50	1149	0.53	1190	0.56	1230	0.59	1270	0.63	1308	0.66
1400	1042	0.47	1080	0.51	1120	0.55	1160	0.58	1200	0.61	1240	0.65	1278	0.68	1315	0.72
1500	1056	0.53	1094	0.57	1133	0.60	1172	0.63	1212	0.67	250	0.70	1288	0.74	1324	0.77
1600	1071	0.58	1109	0.62	1147	0.66	1186	0.69	1225	0.72	1263	0.76	1299	0.80	1334	0.83
1700	1088	0.64	1126	0.68	1164	0.72	1202	0.75	1240	0.78	1276	0.82	1311	0.86	1345	0.90
1800	1107	0.70	1143	0.74	1181	0.78	1219	0.81	1256	0.85	1290	0.89	1324	0.93	1357	0.97
1900	1126	0.77	1163	0.81	1200	0.85	1237	0.88	1273	0.92	1306	0.96	1339	1.00	1371	1.04
2000	1148	0.84	1183	0.88	1220	0.92	1257	0.96	1291	1.00	1323	1.04	1354	1.08	1385	1.12
2100	1170	0.92	1206	0.96	1242	1.00	1277	1.04	1310	1.08	1340	1.13	1370	1.17	1401	1.21
2200	1195	1.00	1230	1.04	1265	1.08	1299	1.13	1330	1.18	1359	1.23	1388	1.27	1418	1.31
2300	1220	1.08	1254	1.13	1288	1.17	1320	1.23	1350	1.28	1378	1.34	1406	1.38	1435	1.42
2400	1245	1.18	1278	1.22	1311	1.28	1341	1.33	1370	1.40	1397	1.45	1425	1.50	1454	1.54

BLOWER DATA

BELT DRIVE - 6 TON

BLOWER TABLE INCLUDES RESISTANCE FOR BASE UNIT ONLY WITH DRY INDOOR COIL AND AIR FILTERS IN PLACE.

FOR ALL UNITS ADD:

1 - Any factory installed options air resistance (economizer, wet coil, etc.).

2 - Any field installed accessories air resistance (electric heat, duct resistance, diffuser, etc.).

See page 40 for blower motors and drives and page 41 for wet coil and options/accessory air resistance data.

DOWNFLOW

KHB074S4T

Air Volume cfm	External Static - in. w.g.															
	0.10		0.20		0.30		0.40		0.50		0.60		0.70		0.80	
	RPM	BHP	RPM	BHP	RPM	BHP	RPM	BHP	RPM	BHP	RPM	BHP	RPM	BHP	RPM	BHP
1900	826	0.36	859	0.41	894	0.45	928	0.50	964	0.56	1000	0.61	1036	0.66	1072	0.70
2000	857	0.42	889	0.47	920	0.52	952	0.57	986	0.62	1020	0.68	1055	0.73	1091	0.77
2100	878	0.49	909	0.54	940	0.59	973	0.64	1006	0.70	1041	0.75	1076	0.80	1112	0.85
2200	897	0.55	929	0.61	961	0.66	994	0.72	1028	0.78	1063	0.83	1099	0.89	1134	0.93
2300	918	0.62	950	0.68	983	0.74	1017	0.80	1052	0.86	1087	0.92	1122	0.97	1157	1.02
2400	941	0.70	974	0.77	1008	0.83	1042	0.90	1077	0.96	1111	1.01	1146	1.06	1181	1.11
2500	966	0.79	1000	0.86	1034	0.93	1068	1.00	1103	1.06	1137	1.11	1171	1.16	1205	1.20
2600	994	0.90	1028	0.97	1062	1.04	1096	1.10	1130	1.16	1164	1.21	1197	1.26	1231	1.30
2700	1023	1.01	1057	1.08	1091	1.15	1125	1.22	1159	1.27	1192	1.32	1225	1.37	1258	1.41
2800	1053	1.13	1088	1.21	1122	1.27	1155	1.33	1188	1.39	1221	1.43	1253	1.48	1286	1.53
2900	1085	1.26	1119	1.33	1153	1.40	1186	1.45	1218	1.51	1250	1.55	1281	1.61	1313	1.66

Air Volume cfm	External Static - in. w.g.															
	0.90		1.00		1.10		1.20		1.30		1.40		1.50		1.60	
	RPM	BHP	RPM	BHP	RPM	BHP	RPM	BHP	RPM	BHP	RPM	BHP	RPM	BHP	RPM	BHP
1900	1109	0.75	1146	0.79	1183	0.82	1221	0.86	1260	0.90	1294	0.94	1323	0.98	1349	1.02
2000	1128	0.82	1164	0.86	1201	0.89	1239	0.93	1276	0.97	1310	1.01	1336	1.06	1362	1.10
2100	1148	0.89	1185	0.93	1221	0.97	1258	1.01	1294	1.05	1325	1.09	1351	1.14	1376	1.19
2200	1170	0.97	1206	1.01	1242	1.05	1277	1.09	1311	1.14	1341	1.18	1365	1.23	1390	1.28
2300	1193	1.06	1228	1.09	1262	1.14	1295	1.19	1327	1.24	1355	1.29	1380	1.33	1406	1.37
2400	1216	1.15	1250	1.19	1282	1.24	1313	1.30	1343	1.36	1371	1.40	1396	1.44	1423	1.48
2500	1240	1.24	1273	1.29	1302	1.36	1331	1.42	1360	1.48	1388	1.52	1414	1.55	1441	1.58
2600	1265	1.34	1296	1.40	1324	1.47	1352	1.54	1381	1.60	1408	1.64	1434	1.67	1460	1.70
2700	1291	1.46	1321	1.52	1347	1.60	1374	1.67	1403	1.72	1429	1.76	1455	1.79	1481	1.82
2800	1317	1.58	1346	1.66	1372	1.74	1399	1.80	1426	1.85	1451	1.89	1477	1.92	1503	1.95
2900	1343	1.72	1371	1.80	1397	1.88	1424	1.95	1450	1.99	1475	2.02	1500	2.05	1526	2.08

BLOWER DATA

BELT DRIVE - 6 TON

BLOWER TABLE INCLUDES RESISTANCE FOR BASE UNIT ONLY WITH DRY INDOOR COIL AND AIR FILTERS IN PLACE.

FOR ALL UNITS ADD:

1 - Any factory installed options air resistance (economizer, wet coil, etc.).

2 - Any field installed accessories air resistance (electric heat, duct resistance, diffuser, etc.).

See page 40 for blower motors and drives and page 41 for wet coil and options/accessory air resistance data.

HORIZONTAL

KHB074S4T

Air Volume cfm	External Static - in. w.g.															
	0.10		0.20		0.30		0.40		0.50		0.60		0.70		0.80	
	RPM	BHP	RPM	BHP	RPM	BHP	RPM	BHP	RPM	BHP	RPM	BHP	RPM	BHP	RPM	BHP
1900	853	0.41	886	0.46	919	0.50	952	0.55	986	0.60	1021	0.64	1056	0.69	1091	0.73
2000	883	0.48	913	0.53	944	0.57	976	0.62	1009	0.67	1043	0.71	1078	0.76	1112	0.80
2100	906	0.56	936	0.60	967	0.65	999	0.70	1033	0.75	1067	0.79	1101	0.84	1135	0.88
2200	930	0.64	960	0.68	991	0.73	1024	0.78	1058	0.83	1092	0.88	1126	0.92	1160	0.96
2300	954	0.72	985	0.77	1017	0.82	1051	0.87	1085	0.92	1119	0.96	1152	1.00	1186	1.04
2400	981	0.81	1013	0.86	1046	0.91	1079	0.96	1113	1.00	1146	1.05	1180	1.09	1213	1.13
2500	1010	0.91	1042	0.96	1075	1.00	1109	1.05	1142	1.09	1175	1.14	1207	1.18	1239	1.23
2600	1040	1.01	1073	1.05	1106	1.10	1139	1.14	1171	1.19	1203	1.23	1235	1.28	1266	1.33
2700	1072	1.10	1104	1.15	1137	1.20	1169	1.24	1201	1.29	1232	1.34	1263	1.40	1293	1.46
2800	1105	1.21	1137	1.25	1168	1.30	1200	1.35	1231	1.40	1261	1.46	1291	1.52	1321	1.59
2900	1138	1.32	1169	1.37	1200	1.42	1231	1.47	1261	1.53	1291	1.60	1321	1.66	1350	1.73

Air Volume cfm	External Static - in. w.g.															
	0.90		1.00		1.10		1.20		1.30		1.40		1.50		1.60	
	RPM	BHP	RPM	BHP	RPM	BHP	RPM	BHP	RPM	BHP	RPM	BHP	RPM	BHP	RPM	BHP
1900	1126	0.77	1163	0.81	1200	0.85	1237	0.88	1273	0.92	1306	0.96	1339	1.00	1371	1.04
2000	1148	0.84	1183	0.88	1220	0.92	1257	0.96	1291	1.00	1323	1.04	1354	1.08	1385	1.12
2100	1170	0.92	1206	0.96	1242	1.00	1277	1.04	1310	1.08	1340	1.13	1371	1.17	1401	1.21
2200	1195	1.00	1230	1.04	1265	1.08	1299	1.13	1330	1.18	1359	1.23	1388	1.27	1418	1.31
2300	1220	1.08	1254	1.13	1288	1.17	1320	1.23	1350	1.28	1378	1.34	1406	1.38	1435	1.42
2400	1245	1.18	1278	1.22	1311	1.28	1341	1.33	1370	1.40	1397	1.45	1425	1.50	1454	1.54
2500	1271	1.28	1303	1.33	1334	1.39	1363	1.45	1391	1.52	1418	1.57	1446	1.62	1474	1.66
2600	1297	1.39	1328	1.45	1357	1.52	1385	1.58	1412	1.64	1439	1.70	1467	1.74	1495	1.78
2700	1323	1.52	1353	1.58	1382	1.65	1409	1.72	1435	1.77	1462	1.82	1490	1.86	1517	1.90
2800	1351	1.65	1380	1.72	1407	1.78	1434	1.85	1460	1.90	1486	1.95	1513	1.99	1541	2.02
2900	1379	1.79	1407	1.86	1434	1.92	1460	1.98	1485	2.04	1511	2.08	1538	2.12	1565	2.15

BLOWER DATA

BELT DRIVE KIT SPECIFICATIONS - STANDARD EFFICIENCY - 036-074

Model No.	Motor HP		No. of Speeds	Drive Kits and RPM Range							
	Nominal	Maximum		A01	A02	A03	A04	A05	A06	A07	A08
036	0.75	0.86	1	673-1010	---	---	---	897-1346	---	---	---
	1	1.15	1	673-1010	---	---	---	897-1346	---	---	---
	1.5	1.7	1	673-1010	---	---	---	897-1346	---	---	---
	2	2.3	1	673-1010	---	---	---	897-1346	---	---	---
048	0.75	0.86	1	---	745-1117	---	---	---	1071-1429	---	---
	1	1.15	1	---	745-1117	---	---	---	1071-1429	---	---
	1.5	1.7	1	---	745-1117	---	---	---	1071-1429	---	---
	2	2.3	1	---	745-1117	---	---	---	1071-1429	---	---
060	0.75	0.86	1	---	---	833-1250	---	---	---	1212-1548	---
	1	1.15	1	---	---	833-1250	---	---	---	1212-1548	---
	1.5	1.7	1	---	---	833-1250	---	---	---	1212-1548	---
	2	2.3	1	---	---	833-1250	---	---	---	1212-1548	---
074	1	1.5	2	---	---	---	968-1340	---	---	---	1193-1591
	2	2.3	2	---	---	---	968-1340	---	---	---	1193-1591

NOTE - Using total air volume and system static pressure requirements determine from blower performance tables rpm and motor hp required. Maximum usable hp of motors furnished are shown. In Canada, nominal motor hp is also maximum usable motor hp. If motors of comparable hp are used, be sure to keep within the service factor limitations outlined on the motor nameplate.

BELT DRIVE KIT SPECIFICATIONS - HIGH EFFICIENCY - 036-060

Model No.	Motor HP		No. of Speeds	Drive Kits and RPM Range						
	Nominal	Maximum		A01	A02	A03	A05	A06	A07	
036	0.75	0.86	2	low 449-673 high 673-1010	---	---	---	---	---	---
	1	1.15	2	---	---	---	low 598-897 high 897-1346	---	---	---
048	0.75	0.86	2	---	low 497-673 high 745-1117	---	---	---	---	---
	2	2.3	2	---	---	---	---	low 714-953 high 1071-1429	---	---
060	1	1.15	2	---	---	low 555-833 high 833-1250	---	---	---	---
	2	2.3	2	---	---	---	---	---	low 808-1032 high 1212-1548	---

NOTE - Using total air volume and system static pressure requirements determine from blower performance tables rpm and motor hp required. Maximum usable hp of motors furnished are shown. In Canada, nominal motor hp is also maximum usable motor hp. If motors of comparable hp are used, be sure to keep within the service factor limitations outlined on the motor nameplate.

OPTIONS / ACCESSORIES AIR RESISTANCE - in. w.g.

Air Volume cfm	Wet Indoor Coil		Economizer	Electric Heat	Filters	
	024, 030, 036, 048	060, 074			MERV 8	MERV 13
800	0.01	0.01	0.04	0.01	0.04	0.05
1000	0.02	0.01	0.04	0.03	0.04	0.07
1200	0.02	0.01	0.04	0.06	0.04	0.07
1400	0.03	0.02	0.04	0.09	0.04	0.07
1600	0.04	0.03	0.04	0.12	0.04	0.07
1800	0.05	0.04	0.05	0.15	0.05	0.07
2000	0.06	0.05	0.05	0.18	0.05	0.08
2200	0.08	0.06	0.05	0.20	0.05	0.08
2400	0.09	0.07	0.05	0.22	0.05	0.08
2600	0.10	0.08	0.06	0.24	0.05	0.08
2800	0.11	0.09	0.06	0.26	0.05	0.08
3000	0.13	0.10	0.06	0.28	0.05	0.08

BLOWER DATA

CEILING DIFFUSERS AIR RESISTANCE (in. w.g.)

Air Volume cfm	RTD9-65S Step-Down Diffuser			FD9-65S Flush Diffuser	RTD11-95S Step-Down Diffuser			FD11-95S Flush Diffuser
	2 Ends Open	1 Side & 2 Ends Open	All Ends & Sides Open		2 Ends Open	1 Side & 2 Ends Open	All Ends & Sides Open	
800	0.15	0.13	0.11	0.11	---	---	---	---
1000	0.19	0.16	0.14	0.14	---	---	---	---
1200	0.25	0.20	0.17	0.17	---	---	---	---
1400	0.33	0.26	0.20	0.20	---	---	---	---
1600	0.43	0.32	0.20	0.24	---	---	---	---
1800	0.56	0.40	0.30	0.30	0.13	0.11	0.09	0.09
2000	0.73	0.50	0.36	0.36	0.15	0.13	0.11	0.10
2200	0.95	0.63	0.44	0.44	0.18	0.15	0.12	0.12
2400	---	----	---	---	0.21	0.18	0.15	0.14
2600	---	----	---	---	0.24	0.21	0.18	0.17
2800	---	----	---	---	0.27	0.24	0.21	0.20
3000	---	----	---	---	0.32	0.29	0.25	0.25

CEILING DIFFUSER AIR THROW DATA

Air Volume - cfm Model No.	1 Effective Throw - ft.	
	RTD9-65S	FD9-65S
800	10 - 17	14 - 18
1000	10 - 17	15 - 20
1200	11 - 18	16 - 22
1400	12 - 19	17 - 24
1600	12 - 20	18 - 25
1800	13 - 21	20 - 28
2000	14 - 23	21 - 29
2200	16 - 25	22 - 30
Model No.	RTD11-95S	FD11-95S
2600	• 24 - 29	• 19 - 24
2800	• 25 - 30	• 20 - 28
3000	• 27 - 33	• 21 - 29

POWER EXHAUST FAN PERFORMANCE

Return Air System Static Pressure - in. w.g.	Air Volume Exhausted cfm
0.00	2000
0.05	1990
0.10	1924
0.15	1810
0.20	1664
0.25	1507
0.30	1350
0.35	1210

¹ Effective throw based on terminal velocities of 75 ft. per minute.

OUTDOOR SOUND DATA

¹ Unit Model No.	Octave Band Sound Power Levels dBA, re 10 ⁻¹² Watts - Center Frequency - Hz							¹ Sound Rating Number (dBA)
	125	250	500	1000	2000	4000	8000	
KHB024S KHB030S KHB036S	62	67	72	69	66	61	56	75
KHB048S	61	67	70	70	68	63	56	75
KHB060S	69	72	75	74	70	65	55	80
KHB074S	67	75	78	78	75	68	59	83
KHB024H	62	67	70	70	64	57	51	74
KHB036H	62	66	71	69	64	57	51	75
KHB048H	67	68	73	72	68	63	53	77
KHB060H	66	68	71	72	69	63	56	77

NOTE - The octave sound power data does not include tonal corrections.

¹ Sound Rating Number according to AHRI Standard 270-95 (includes pure tone penalty). Sound Rating Number is the overall A-Weighted Sound Power Level, (LWA), dBA (100 Hz to 10,000 Hz).

ELECTRICAL/ELECTRIC HEAT DATA STANDARD EFFICIENCY - DIRECT DRIVE - 2 | 2.5 TON

Model No.		KHB024S4D	KHB030S4D
¹ Voltage - 60Hz		208/230V - 1 Ph	208/230V - 1 Ph
Compressor 1	Rated Load Amps	9.8	12.7
	Locked Rotor Amps	47	64
Outdoor Fan Motors (1)	Full Load Amps (total)	1.7	1.7
Service Outlet 115V GFI (amps)		15	15
Indoor Blower Motor	Horsepower	0.25	0.25
	Type	Direct	Direct
	Full Load Amps	1.8	1.8
² Maximum Overcurrent Protection	Unit Only	25	30
³ Minimum Circuit Ampacity	Unit Only	16	20

ELECTRIC HEAT DATA

Electric Heat Voltage			208V	240V	208V	240V
² Maximum Overcurrent Protection	Unit + Electric Heat	5 kW	40	45	50	50
		7.5 kW	50	60	60	60
		10 kW	70	70	70	80
³ Minimum Circuit Ampacity	Unit + Electric Heat	5 kW	39	42	42	46
		7.5 kW	50	55	54	59
		10 kW	61	68	65	72

ELECTRICAL ACCESSORIES

Disconnect	Standard Access - 0-10 kW	20W15	20W15	20W15	20W15
	Hinged Access - 0-10 kW	20W21	20W21	20W21	20W21

NOTE - All units have a minimum Short Circuit Current Rating (SCCR) of 5000 amps.

¹ Extremes of operating range are plus and minus 10% of line voltage.

² HACR type breaker or fuse.

³ Refer to National or Canadian Electrical Code manual to determine wire, fuse and disconnect size requirements.

ELECTRICAL/ELECTRIC HEAT
STANDARD EFFICIENCY - DIRECT DRIVE - 3 TON

Model No.		KHB036S4D			
¹ Voltage - 60Hz		208/230V - 1 Ph	208/230V - 3 Ph	460V - 3 Ph	575V - 3 Ph
Compressor	Rated Load Amps	15.3	8.7	4	3.6
	Locked Rotor Amps	70	70	31	27
Outdoor Fan Motors (1)	Full Load Amps (total)	1.7	1.7	1.1	0.7
Power Exhaust (1) 0.33 HP	Full Load Amps (total)	2.4	2.4	1.3	1
Service Outlet 115V GFI (amps)		15	15	15	20
Indoor Blower Motor	Horsepower	0.5	0.5	0.5	0.5
	Type	Direct	Direct	Direct	Direct
	Full Load Amps	3.9	3.9	2	2
² Maximum Overcurrent Protection	Unit Only	40	25	15	15
	with (1) 0.33 HP Power Exhaust	40	25	15	15
³ Minimum Circuit Ampacity	Unit Only	25	17	9	8
	with (1) 0.33 HP Power Exhaust	28	19	10	9

ELECTRIC HEAT DATA

Electric Heat Voltage			208V	240V	208V	240V	480V	600V
² Maximum Overcurrent Protection	Unit + 7.5 kW	Electric Heat	60	70	40	40	20	20
		15 kW	100	110	60	70	35	30
³ Minimum Circuit Ampacity	Unit + 7.5 kW	Electric Heat	59	64	37	40	20	17
		15 kW	93	103	56	62	31	26
² Maximum Overcurrent Protection	Unit + 7.5 kW	Electric Heat + Power Exhaust	70	70	40	45	25	20
		15 kW	100	110	60	70	35	30
³ Minimum Circuit Ampacity	Unit + 7.5 kW	Electric Heat + Power Exhaust	61	67	39	42	21	18
		15 kW	95	106	58	64	32	27

ELECTRICAL ACCESSORIES

Disconnect	Standard Access - 0-7.5 kW	20W15	20W15	20W15	20W15
	15 kW	20W16	20W15	20W15	20W15
	Hinged Access - 0-7.5 kW	20W21	20W21	20W21	20W21
	15 kW	20W22	20W21	20W21	20W21

NOTE - All units have a minimum Short Circuit Current Rating (SCCR) of 5000 amps.

¹ Extremes of operating range are plus and minus 10% of line voltage.

² HACR type breaker or fuse.

³ Refer to National or Canadian Electrical Code manual to determine wire, fuse and disconnect size requirements.

ELECTRICAL/ELECTRIC HEAT DATA STANDARD EFFICIENCY - DIRECT DRIVE - 4 TON

Model No.		KHB048S4D			
¹ Voltage - 60Hz		208/230V - 1 Ph	208/230V - 3 Ph	460V - 3 Ph	575V - 3 Ph
Compressor	Rated Load Amps	20	11	5.5	4.7
	Locked Rotor Amps	99	86	37	34
Outdoor Fan Motors (1)	Full Load Amps (total)	1.7	1.7	1.1	0.7
Power Exhaust (1) 0.33 HP	Full Load Amps (total)	2.4	2.4	1.3	1
Service Outlet 115V GFI (amps)		15	15	15	20
Indoor Blower Motor	Horsepower	0.5	0.5	0.5	0.5
	Type	Direct	Direct	Direct	Direct
	Full Load Amps	3.9	3.9	2	2
² Maximum Overcurrent Protection	Unit Only	50	30	15	15
	with (1) 0.33 HP Power Exhaust	50	30	15	15
³ Minimum Circuit Ampacity	Unit Only	31	20	10	9
	with (1) 0.33 HP Power Exhaust	33	22	12	10

ELECTRIC HEAT DATA

Electric Heat Voltage			208V	240V	208V	240V	480V	600V
² Maximum Overcurrent Protection	Unit + 7.5 kW	Electric Heat 15 kW	70	80	45	45	25	20
			100	110	60	70	35	30
³ Minimum Circuit Ampacity	Unit + 7.5 kW	Electric Heat 15 kW	65	70	39	42	22	18
			99	109	59	65	33	27
² Maximum Overcurrent Protection	Unit + 7.5 kW	Electric Heat + Power Exhaust 15 kW	80	80	45	50	25	20
			110	125	70	70	35	30
³ Minimum Circuit Ampacity	Unit + 7.5 kW	Electric Heat + Power Exhaust 15 kW	67	73	42	45	23	19
			101	112	61	67	34	28

ELECTRICAL ACCESSORIES

Disconnect	Standard Access - 0-7.5 kW	15 kW	22A20	22A20	22A20	22A20
			22A21	22A20	22A20	22A20
	Hinged Access - 0-7.5 kW	15 kW	22A23	22A23	22A23	22A23
			22A24	22A23	22A23	22A23

NOTE - All units have a minimum Short Circuit Current Rating (SCCR) of 5000 amps.

¹ Extremes of operating range are plus and minus 10% of line voltage.

² HACR type breaker or fuse.

³ Refer to National or Canadian Electrical Code manual to determine wire, fuse and disconnect size requirements.

ELECTRICAL/ELECTRIC HEAT DATA

STANDARD EFFICIENCY - BELT DRIVE - 3 TON

Model No.		KHB036S4B							
¹ Voltage - 60Hz		208/230V - 1 Ph		208/230V - 3 Ph		460V - 3 Ph		575V - 3 Ph	
Compressor	Rated Load Amps	15.3		8.7		4		3.6	
	Locked Rotor Amps	70		70		31		27	
Outdoor Fan Motors (1)	Full Load Amps (total)	1.7		1.7		1.1		0.7	
Power Exhaust (1) 0.33 HP	Full Load Amps (total)	2.4		2.4		1.3		1	
Service Outlet 115V GFI (amps)		15		15		15		20	
Indoor Blower Motor	Horsepower	0.75	1.5	1	2	1	2	1	2
	Type	Belt	Belt	Belt	Belt	Belt	Belt	Belt	Belt
	Full Load Amps	7.6	11	4.6	7.5	2.1	3.4	1.7	2.7
² Maximum Overcurrent Protection	Unit Only	40	45	25	25	15	15	15	15
	with (1) 0.33 HP Power Exhaust	45	45	25	30	15	15	15	15
³ Minimum Circuit Ampacity	Unit Only	29	32	18	21	9	10	7	8
	with (1) 0.33 HP Power Exhaust	31	35	20	23	10	11	8	9

ELECTRIC HEAT DATA

Electric Heat Voltage			208V	240V	208V	240V	208V	240V	208V	240V	480V	480V	600V	600V
² Maximum Overcurrent Protection	Unit + 7.5 kW	Electric Heat	70	70	70	80	40	40	40	45	20	25	20	20
	Unit + 15 kW	Electric Heat	100	110	100	110	60	70	60	70	35	35	25	30
³ Minimum Circuit Ampacity	Unit + 7.5 kW	Electric Heat	63	68	66	71	37	40	40	43	20	21	16	17
	Unit + 15 kW	Electric Heat	97	107	100	110	57	63	60	66	31	33	25	26
² Maximum Overcurrent Protection	Unit + 7.5 kW	Electric Heat + Power Exhaust	70	70	70	80	40	45	45	50	25	25	20	20
	Unit + 15 kW	Electric Heat + Power Exhaust	100	110	110	125	60	70	70	70	35	35	30	30
³ Minimum Circuit Ampacity	Unit + 7.5 kW	Electric Heat + Power Exhaust	65	70	69	74	40	43	43	46	21	23	17	18
	Unit + 15 kW	Electric Heat + Power Exhaust	99	109	102	113	59	65	62	68	33	34	26	27

ELECTRICAL ACCESSORIES

Disconnect	Standard Access - 0-7.5 kW	20W15	20W15	20W15	20W15	20W15
	15 kW	20W16	20W15	20W15	20W15	20W15
	Hinged Access - 0-7.5 kW	20W21	20W21	20W21	20W21	20W21
	15 kW	20W22	20W21	20W21	20W21	20W21

NOTE - All units have a minimum Short Circuit Current Rating (SCCR) of 5000 amps.

¹ Extremes of operating range are plus and minus 10% of line voltage.

² HACR type breaker or fuse.

³ Refer to National or Canadian Electrical Code manual to determine wire, fuse and disconnect size requirements.

ELECTRICAL/ELECTRIC HEAT DATA STANDARD EFFICIENCY - BELT DRIVE - 4 TON

Model No.		KHB048S4B							
¹ Voltage - 60Hz		208/230V - 1 Ph		208/230V - 3 Ph		460V - 3 Ph		575V - 3 Ph	
Compressor	Rated Load Amps	20		11		5.5		4.7	
	Locked Rotor Amps	99		86		37		34	
Outdoor Fan Motors (1)	Full Load Amps (total)	1.7		1.7		1.1		0.7	
Power Exhaust (1) 0.33 HP	Full Load Amps (total)	2.4		2.4		1.3		1	
Service Outlet 115V GFI (amps)		15		15		15		20	
Indoor Blower Motor	Horsepower	0.75	1.5	1	2	1	2	1	2
	Type	Belt	Belt	Belt	Belt	Belt	Belt	Belt	Belt
	Full Load Amps	7.6	11	4.6	7.5	2.1	3.4	1.7	2.7
² Maximum Overcurrent Protection	Unit Only	50	50	30	30	15	15	15	15
	with (1) 0.33 HP Power Exhaust	50	60	30	35	15	15	15	15
³ Minimum Circuit Ampacity	Unit Only	35	38	21	23	11	12	9	10
	with (1) 0.33 HP Power Exhaust	37	41	23	26	12	13	10	11

ELECTRIC HEAT DATA

Electric Heat Voltage			208V	240V	208V	240V	208V	240V	208V	240V	480V	480V	600V	600V
² Maximum Overcurrent Protection	Unit + Electric Heat	7.5 kW	80	80	80	80	45	45	45	50	25	25	20	20
		15 kW	110	125	110	125	60	70	70	70	35	35	30	30
³ Minimum Circuit Ampacity	Unit + Electric Heat	7.5 kW	69	74	72	77	40	43	43	46	22	23	18	19
		15 kW	103	113	106	116	60	66	63	69	33	34	27	28
² Maximum Overcurrent Protection	Unit + Electric Heat + Power Exhaust	7.5 kW	80	80	80	90	45	50	50	50	25	25	20	20
		15 kW	100	110	110	125	70	70	70	80	35	40	30	30
³ Minimum Circuit Ampacity	Unit + Electric Heat + Power Exhaust	7.5 kW	71	76	74	80	42	46	45	48	23	24	19	20
		15 kW	105	115	108	119	62	68	65	71	34	36	28	29

ELECTRICAL ACCESSORIES

Disconnect	Standard Access - 0-7.5 kW	22A20	22A20	22A20	22A20	22A20
		15 kW	22A21	22A20	22A20	22A20
	Hinged Access - 0-7.5 kW	22A23	22A23	22A23	22A23	22A23
		15 kW	22A24	22A23	22A23	22A23

NOTE - All units have a minimum Short Circuit Current Rating (SCCR) of 5000 amps.

¹ Extremes of operating range are plus and minus 10% of line voltage.

² HACR type breaker or fuse.

³ Refer to National or Canadian Electrical Code manual to determine wire, fuse and disconnect size requirements.

ELECTRICAL/ELECTRIC HEAT DATA

STANDARD EFFICIENCY - BELT DRIVE - 5 TON

Model No.		KHB060S4B							
¹ Voltage - 60Hz		208/230V - 1 Ph		208/230V - 3 Ph		460V - 3 Ph		575V - 3 Ph	
Compressor	Rated Load Amps	22.1		13.5		8		5	
	Locked Rotor Amps	125		109		59		40	
Outdoor Fan Motors (1)	Full Load Amps (total)	2.4		2.4		1.3		1	
Power Exhaust (1) 0.33 HP	Full Load Amps (total)	2.4		2.4		1.3		1	
Service Outlet 115V GFI (amps)		15		15		15		20	
Indoor Blower Motor	Horsepower	0.75	1.5	1	2	1	2	1	2
	Type	Belt	Belt	Belt	Belt	Belt	Belt	Belt	Belt
	Full Load Amps	7.6	11	4.6	7.5	2.1	3.4	1.7	2.7
² Maximum Overcurrent Protection	Unit Only	50	60	35	40	20	20	15	15
	with (1) 0.33 HP Power Exhaust	60	60	35	40	20	20	15	15
³ Minimum Circuit Ampacity	Unit Only	38	42	24	27	14	15	9	10
	with (1) 0.33 HP Power Exhaust	41	44	27	30	15	16	10	11

ELECTRIC HEAT DATA

Electric Heat Voltage			208V	240V	208V	240V	208V	240V	208V	240V	480V	480V	600V	600V
² Maximum Overcurrent Protection	Unit + Electric Heat	7.5 kW	80	90	90	90	50	50	50	50	30	30	20	20
		15 kW	110	125	110	125	70	70	70	80	40	40	30	30
		22.5 kW	150	175	150	175	90	100	90	100	50	50	40	40
³ Minimum Circuit Ampacity	Unit + Electric Heat	7.5 kW	72	77	75	81	44	47	47	50	25	26	18	19
		15 kW	106	116	109	120	63	69	66	72	36	38	27	28
		22.5 kW	140	155	143	159	83	92	86	95	48	49	37	38
² Maximum Overcurrent Protection	Unit + Electric Heat + Power Exhaust	7.5 kW	80	90	90	90	50	50	50	60	30	30	20	20
		15 kW	110	125	125	125	70	80	70	80	40	40	30	30
		22.5 kW	150	175	150	175	90	100	90	100	50	50	40	40
³ Minimum Circuit Ampacity	Unit + Electric Heat + Power Exhaust	7.5 kW	74	80	78	83	46	49	49	52	26	28	19	20
		15 kW	108	119	112	122	66	72	69	75	38	39	28	29
		22.5 kW	142	158	145	161	85	94	88	97	49	50	38	39

ELECTRICAL ACCESSORIES

Disconnect	Standard Access - 0-7.5 kW	22A21	22A20	22A20	22A20	22A20	22A20	
		15 kW	22A21	22A21	22A20	22A20	22A20	22A20
		22.5 kW	22A21	N/A	22A21	22A21	22A20	22A20
	Hinged Access - 0-7.5 kW	22A24	22A23	22A23	22A23	22A23	22A23	
		15 kW	22A24	22A24	22A23	22A23	22A23	
		22.5 kW	22A24	N/A	22A24	22A24	22A23	

NOTE - All units have a minimum Short Circuit Current Rating (SCCR) of 5000 amps.

¹ Extremes of operating range are plus and minus 10% of line voltage.

² HACR type breaker or fuse.

³ Refer to National or Canadian Electrical Code manual to determine wire, fuse and disconnect size requirements.

ELECTRICAL/ELECTRIC HEAT DATA STANDARD EFFICIENCY - BELT DRIVE - 6 TON

Model No.		KHB074S4T							
¹ Voltage - 60Hz		208/230V - 3 Ph		460V - 3 Ph		575V - 3 Ph			
Compressor	Rated Load Amps	17.6		8.5		6.3			
	Locked Rotor Amps	136		66.1		55.3			
Outdoor Fan Motor	Full Load Amps	3		1.5		1.2			
Power Exhaust (1) 0.33 HP	Full Load Amps	2.4		1.3		1			
Service Outlet 115V GFI (amps)		15		15		20			
Indoor Blower Motor	Horsepower	1		2		1		2	
	Type	Belt (2 Speed)		Belt (2 Speed)		Belt (2 Speed)		Belt (2 Speed)	
	Full Load Amps	4.6		7.5		2.1		3.4	
² Maximum Overcurrent Protection	Unit Only	45		50		20		20	
	With (1) 0.33 HP Power Exhaust	45		50		20		25	
³ Minimum Circuit Ampacity	Unit Only	30		33		15		16	
	With (1) 0.33 HP Power Exhaust	32		35		16		17	

ELECTRIC HEAT DATA

Electric Heat Voltage			208	240	208	240	480	480	600	600
² Maximum Overcurrent Protection	Unit+ Electric Heat	7.5 kW	60	60	60	60	30	30	20	25
		15 kW	70	80	80	80	40	40	30	30
		22.5 kW	90	100	100	110	50	50	40	40
		30 kW	110	125	125	125	60	70	50	50
³ Minimum Circuit Ampacity	Unit+ Electric Heat	7.5 kW	50	53	53	56	26	27	20	21
		15 kW	69	75	72	78	37	39	29	30
		22.5 kW	89	98	92	101	49	50	38	39
		30 kW	108	120	111	123	60	61	47	48
² Maximum Overcurrent Protection	Unit+ Electric Heat and (1) 0.33 HP Power Exhaust	7.5 kW	60	60	60	70	30	30	25	25
		15 kW	80	80	80	90	40	40	30	35
		22.5 kW	100	100	100	110	50	60	40	40
		30 kW	125	125	125	150	70	70	50	50
³ Minimum Circuit Ampacity	Unit+ Electric Heat and (1) 0.33 HP Power Exhaust	7.5 kW	52	55	55	58	27	29	21	22
		15 kW	72	78	74	81	39	40	30	31
		22.5 kW	91	100	94	103	50	51	39	40
		30 kW	111	123	114	126	61	62	48	49

ELECTRICAL ACCESSORIES

Disconnect Kit	Standard Access - 0-15 kW	22A20	22A20	22A20	22A20
		22A21	22A21	22A20	22A20
	Hinged Access - 0-15 kW	22A23	22A23	22A23	22A23
		22A24	22A24	22A23	22A23

NOTE - All units have a minimum Short Circuit Current Rating (SCCR) of 5000 amps.

¹ Extremes of operating range are plus and minus 10% of line voltage.

² HACR type breaker or fuse.

³ Refer to National or Canadian Electrical Code manual to determine wire, fuse and disconnect size requirements.

ELECTRICAL/ELECTRIC HEAT DATA HIGH EFFICIENCY - DIRECT DRIVE - 2 TON | 3 TON

Model No.		KHB024H4E	KHB036H4E			
¹ Voltage - 60Hz		208/230V - 1 Ph	208/230V - 1 Ph	208/230V - 3 Ph	460V - 3 Ph	575V - 3 Ph
Compressor 1	Rated Load Amps	11.7	15.3	11.6	5.7	4
	Locked Rotor Amps	58.3	83	73	38	25.6
Outdoor Fan Motors (1)	Full Load Amps (total)	2.8	2.8	2.8	1.4	1.1
Power Exhaust (1) 0.33 HP	Full Load Amps (total)	2.4	2.4	2.4	1.3	1
Service Outlet 115V GFI (amps)		15	15	15	15	20
Indoor Blower Motor	Horsepower	0.33	0.50	0.50	0.50	0.50
	Type	ECM	ECM	ECM	ECM	ECM
	Full Load Amps	2.9	4.6	4.6	2.3	1.8
² Maximum Overcurrent Protection	Unit Only	30	40	30	15	15
	with (1) 0.33 HP Power Exhaust	---	40	35	15	15
³ Minimum Circuit Ampacity	Unit Only	21	27	22	11	8
	with (1) 0.33 HP Power Exhaust	---	29	25	13	9

ELECTRIC HEAT DATA

Electric Heat Voltage			208V	240V	208V	240V	208V	240V	480V	600V
² Maximum Overcurrent Protection	Unit + Electric Heat	5 kW	50	50	---	---	---	---	---	---
		7.5 kW	60	60	70	70	45	50	25	20
		10 kW	70	80	---	---	---	---	---	---
		15 kW	---	---	100	110	70	70	35	30
³ Minimum Circuit Ampacity	Unit + Electric Heat	5 kW	43	47	---	---	---	---	---	---
		7.5 kW	55	60	61	66	42	45	23	17
		10 kW	66	73	---	---	---	---	---	---
		15 kW	---	---	95	105	61	68	34	26
² Maximum Overcurrent Protection	Unit + Electric Heat + Power Exhaust	5 kW	---	---	---	---	---	---	---	---
		7.5 kW	---	---	70	70	50	50	25	20
		10 kW	---	---	---	---	---	---	---	---
		15 kW	---	---	100	110	70	70	35	30
³ Minimum Circuit Ampacity	Unit + Electric Heat + Power Exhaust	5 kW	---	---	---	---	---	---	---	---
		7.5 kW	---	---	63	68	44	47	24	18
		10 kW	---	---	---	---	---	---	---	---
		15 kW	---	---	97	108	64	70	35	27

ELECTRICAL ACCESSORIES

Disconnect	Standard Access - 0-10 kW	0-7.5 kW	20W15	---	---	---	---
		7.5 kW	---	20W15	20W15	20W15	20W15
		15 kW	---	20W16	20W15	20W15	20W15
	Hinged Access - 0-10 kW	0-7.5 kW	20W21	---	---	---	---
		7.5 kW	---	20W21	20W21	20W21	20W21
		15 kW	---	20W22	20W21	20W21	20W21

NOTE - All units have a minimum Short Circuit Current Rating (SCCR) of 5000 amps.

¹ Extremes of operating range are plus and minus 10% of line voltage.

² HACR type breaker or fuse.

³ Refer to National or Canadian Electrical Code manual to determine wire, fuse and disconnect size requirements.

ELECTRICAL/ELECTRIC HEAT DATA
HIGH EFFICIENCY - DIRECT DRIVE - 4 TON

Model No.		KHB048H4E			
¹ Voltage - 60Hz		208/230V - 1 Ph	208/230V - 3 Ph	460V - 3 Ph	575V - 3 Ph
Compressor	Rated Load Amps	21.2	14	6.4	4.6
	Locked Rotor Amps	104	83.1	41	33
Outdoor Fan Motors (1)	Full Load Amps (total)	2.8	2.8	1.4	1.1
Power Exhaust (1) 0.33 HP	Full Load Amps (total)	2.4	2.4	1.3	1
Service Outlet 115V GFI (amps)		15	15	15	20
Indoor Blower Motor	Horsepower	0.75	0.75	0.75	0.75
	Type	ECM	ECM	ECM	ECM
	Full Load Amps	6.3	6.3	3.2	2.5
² Maximum Overcurrent Protection	Unit Only	50	40	15	15
	with (1) 0.33 HP Power Exhaust	50	40	20	15
³ Minimum Circuit Ampacity	Unit Only	36	27	13	10
	with (1) 0.33 HP Power Exhaust	38	29	14	11

ELECTRIC HEAT DATA

Electric Heat Voltage			208V	240V	208V	240V	480V	600V
² Maximum Overcurrent Protection	Unit + 7.5 kW	Electric Heat	80	80	50	50	25	20
		15 kW	110	125	70	80	40	30
³ Minimum Circuit Ampacity	Unit + 7.5 kW	Electric Heat	70	75	47	50	24	19
		15 kW	104	114	66	72	36	28
² Maximum Overcurrent Protection	Unit + 7.5 kW	Electric Heat + Power Exhaust	80	90	50	60	30	20
		15 kW	110	125	70	80	40	30
³ Minimum Circuit Ampacity	Unit + 7.5 kW	Electric Heat + Power Exhaust	72	78	49	52	26	20
		15 kW	106	117	69	75	37	29

ELECTRICAL ACCESSORIES

Disconnect	Standard Access - 0-7.5 kW	15 kW	22A20	22A20	22A20	22A20
			22A21	22A20	22A20	22A20
	Hinged Access - 0-7.5 kW	15 kW	22A23	22A23	22A23	22A23
			22A24	22A23	22A23	22A23

NOTE - All units have a minimum Short Circuit Current Rating (SCCR) of 5000 amps.

¹ Extremes of operating range are plus and minus 10% of line voltage.

² HACR type breaker or fuse.

³ Refer to National or Canadian Electrical Code manual to determine wire, fuse and disconnect size requirements.

ELECTRICAL/ELECTRIC HEAT DATA
HIGH EFFICIENCY - DIRECT DRIVE - 5 TON

Model No.		KHB060H4E			
¹ Voltage - 60Hz		208/230V - 1 Ph	208/230V - 3 Ph	460V - 3 Ph	575V - 3 Ph
Compressor	Rated Load Amps	27.1	16.5	7.2	5.5
	Locked Rotor Amps	152.9	110	52	38.9
Outdoor Fan Motors (1)	Full Load Amps (total)	2.8	2.8	1.4	1.1
Power Exhaust (1) 0.33 HP	Full Load Amps (total)	2.4	2.4	1.3	1
Service Outlet 115V GFI (amps)		15	15	15	20
Indoor Blower Motor	Horsepower	1	1	1	1
	Type	ECM	ECM	ECM	ECM
	Full Load Amps	8.4	8.4	4.2	3.4
² Maximum Overcurrent Protection	Unit Only	70	45	20	15
	with (1) 0.33 HP Power Exhaust	70	50	20	15
³ Minimum Circuit Ampacity	Unit Only	46	32	15	12
	with (1) 0.33 HP Power Exhaust	48	35	16	13

ELECTRIC HEAT DATA

Electric Heat Voltage			208V	240V	208V	240V	480V	600V
² Maximum Overcurrent Protection	Unit +	7.5 kW	90	100	60	60	30	25
	Electric Heat	15 kW	125	125	80	80	40	30
		22.5 kW	150	175	100	100	50	40
³ Minimum Circuit Ampacity	Unit +	7.5 kW	79	85	52	55	26	21
	Electric Heat	15 kW	113	124	71	77	38	30
		22.5 kW	147	163	91	100	49	39
² Maximum Overcurrent Protection	Unit +	7.5 kW	100	100	60	60	30	25
	Electric Heat + Power Exhaust	15 kW	125	150	80	80	40	35
		22.5 kW	150	175	100	110	50	40
³ Minimum Circuit Ampacity	Unit +	7.5 kW	82	87	54	57	28	22
	Electric Heat + Power Exhaust	15 kW	116	126	74	80	39	31
		22.5 kW	150	165	93	102	50	40

ELECTRICAL ACCESSORIES

Disconnect	Standard Access - 0-7.5 kW	22A20	22A20	22A20	22A20
		15 kW	22A21	22A20	22A20
		22.5 kW	22A21	22A21	22A20
	Hinged Access - 0-7.5 kW	22A24	22A23	22A23	22A23
		15 kW	22A24	22A23	22A23
		22.5 kW	22A24	22A24	22A23

NOTE - All units have a minimum Short Circuit Current Rating (SCCR) of 5000 amps.

¹ Extremes of operating range are plus and minus 10% of line voltage.

² HACR type breaker or fuse.

³ Refer to National or Canadian Electrical Code manual to determine wire, fuse and disconnect size requirements.

ELECTRICAL/ELECTRIC HEAT DATA
HIGH EFFICIENCY - BELT DRIVE - 3 TON

Model No.		KHB036H4T					
¹ Voltage - 60Hz		208/230V - 3 Ph		460V - 3 Ph		575V - 3 Ph	
Compressor	Rated Load Amps	11.6		5.7		4	
	Locked Rotor Amps	73		38		25.6	
Outdoor Fan Motors (1)	Full Load Amps (total)	2.8		1.4		1.1	
Power Exhaust (1) 0.33 HP	Full Load Amps (total)	2.4		1.3		1	
Service Outlet 115V GFI (amps)		15		15		20	
Indoor Blower Motor	Horsepower	0.75	1	0.75	1	0.75	1
	Type	Belt (2 Speed)	Belt (2 Speed)	Belt (2 Speed)	Belt (2 Speed)	Belt (2 Speed)	Belt (2 Speed)
	Full Load Amps	3.5	4.6	1.6	2.1	1.3	1.7
² Maximum Overcurrent Protection	Unit Only	30	30	15	15	15	15
	with (1) 0.33 HP Power Exhaust	30	35	15	15	15	15
³ Minimum Circuit Ampacity	Unit Only	21	22	11	11	8	8
	with (1) 0.33 HP Power Exhaust	24	25	12	12	9	9

ELECTRIC HEAT DATA

Electric Heat Voltage			208V	240V	208V	240V	480V	480V	600V	600V
² Maximum Overcurrent Protection	Unit + Electric Heat	7.5 kW	45	50	45	50	25	25	20	20
		15 kW	60	70	70	70	35	35	30	30
³ Minimum Circuit Ampacity	Unit + Electric Heat	7.5 kW	41	44	42	45	22	22	17	17
		15 kW	60	66	61	68	33	34	26	26
² Maximum Overcurrent Protection	Unit + Electric Heat + Power Exhaust	7.5 kW	50	50	50	50	25	25	20	20
		15 kW	70	70	70	70	35	35	30	30
³ Minimum Circuit Ampacity	Unit + Electric Heat + Power Exhaust	7.5 kW	43	46	44	47	23	24	18	18
		15 kW	63	69	64	70	34	35	27	27

ELECTRICAL ACCESSORIES

Disconnect	Standard Access -	0-7.5 kW	20W15	20W15	20W15	20W15
		15 kW	20W15	20W15	20W15	20W15
	Hinged Access -	0-7.5 kW	20W21	20W21	20W21	20W21
		15 kW	20W21	20W21	20W21	20W21

NOTE - All units have a minimum Short Circuit Current Rating (SCCR) of 5000 amps.

¹ Extremes of operating range are plus and minus 10% of line voltage.

² HACR type breaker or fuse.

³ Refer to National or Canadian Electrical Code manual to determine wire, fuse and disconnect size requirements.

ELECTRICAL/ELECTRIC HEAT DATA

HIGH EFFICIENCY - BELT DRIVE - 4 TON

Model No.		KHB048H4T					
¹ Voltage - 60Hz		208/230V - 3 Ph		460V - 3 Ph		575V - 3 Ph	
Compressor	Rated Load Amps	14		6.4		4.6	
	Locked Rotor Amps	83.1		41		33	
Outdoor Fan Motors (1)	Full Load Amps (total)	2.8		1.4		1.1	
Power Exhaust (1) 0.33 HP	Full Load Amps (total)	2.4		1.3		1	
Service Outlet 115V GFI (amps)		15		15		20	
Indoor Blower Motor	Horsepower	0.80	2	0.75	2	0.75	2
	Type	Belt (2 Speed)	Belt (2 Speed)	Belt (2 Speed)	Belt (2 Speed)	Belt (2 Speed)	Belt (2 Speed)
	Full Load Amps	3.5	7.5	1.6	3.4	1.3	2.7
² Maximum Overcurrent Protection	Unit Only	35	40	15	15	15	15
	with (1) 0.33 HP Power Exhaust	40	40	15	20	15	15
³ Minimum Circuit Ampacity	Unit Only	24	28	11	13	9	10
	with (1) 0.33 HP Power Exhaust	27	31	13	15	10	11

ELECTRIC HEAT DATA

Electric Heat Voltage			208V	240V	208V	240V	480V	480V	600V	600V
² Maximum Overcurrent Protection	Unit + Electric Heat	7.5 kW	50	50	50	60	25	25	20	20
		15 kW	70	70	70	80	35	40	30	30
³ Minimum Circuit Ampacity	Unit + Electric Heat	7.5 kW	44	47	48	51	23	25	18	19
		15 kW	63	69	67	73	34	36	27	28
² Maximum Overcurrent Protection	Unit + Electric Heat + Power Exhaust	7.5 kW	50	50	50	60	25	30	20	20
		15 kW	70	80	70	80	35	40	30	30
³ Minimum Circuit Ampacity	Unit + Electric Heat + Power Exhaust	7.5 kW	46	49	50	53	24	26	19	20
		15 kW	66	72	70	76	35	37	28	29

ELECTRICAL ACCESSORIES

Disconnect	Standard Access - 0-7.5 kW	7.5 kW	22A20	22A20	22A20	22A20
		15 kW	22A20	22A20	22A20	22A20
	Hinged Access - 0-7.5 kW	7.5 kW	22A23	22A23	22A23	22A23
		15 kW	22A23	22A23	22A23	22A23

NOTE - All units have a minimum Short Circuit Current Rating (SCCR) of 5000 amps.

¹ Extremes of operating range are plus and minus 10% of line voltage.

² HACR type breaker or fuse.

³ Refer to National or Canadian Electrical Code manual to determine wire, fuse and disconnect size requirements.

ELECTRICAL/ELECTRIC HEAT DATA
HIGH EFFICIENCY - BELT DRIVE - 5 TON

Model No.		KHB060H4T					
¹ Voltage - 60Hz		208/230V - 3 Ph		460V - 3 Ph		575V - 3 Ph	
Compressor	Rated Load Amps	16.5		7.2		5.5	
	Locked Rotor Amps	110		52		38.9	
Outdoor Fan Motors (1)	Full Load Amps (total)	2.8		1.4		1.1	
Power Exhaust (1) 0.33 HP	Full Load Amps (total)	2.4		1.3		1	
Service Outlet 115V GFI (amps)		15		15		20	
Indoor Blower Motor	Horsepower	1	2	1	2	1	2
	Type	Belt (2 Speed)	Belt (2 Speed)	Belt (2 Speed)	Belt (2 Speed)	Belt (2 Speed)	Belt (2 Speed)
	Full Load Amps	4.6	7.5	2.1	3.4	1.7	2.7
² Maximum Overcurrent Protection	Unit Only	40	45	15	20	15	15
	with (1) 0.33 HP Power Exhaust	45	45	20	20	15	15
³ Minimum Circuit Ampacity	Unit Only	29	31	13	14	10	11
	with (1) 0.33 HP Power Exhaust	31	34	14	16	11	12

ELECTRIC HEAT DATA

Electric Heat Voltage			208V	240V	208V	240V	480V	480V	600V	600V
² Maximum Overcurrent Protection	Unit + Electric Heat	7.5 kW	60	60	60	60	25	30	20	20
		15 kW	70	80	80	80	40	40	30	30
		22.5 kW	90	100	90	100	50	50	40	40
³ Minimum Circuit Ampacity	Unit + Electric Heat	7.5 kW	48	51	51	54	24	26	19	20
		15 kW	68	74	71	77	36	37	28	29
		22.5 kW	87	96	90	99	47	48	37	38
² Maximum Overcurrent Protection	Unit + Electric Heat + Power Exhaust	7.5 kW	60	60	60	60	30	30	20	25
		15 kW	70	80	80	80	40	40	30	30
		22.5 kW	90	100	100	110	50	50	40	40
³ Minimum Circuit Ampacity	Unit + Electric Heat + Power Exhaust	7.5 kW	50	53	53	56	26	27	20	21
		15 kW	70	76	73	79	37	38	29	30
		22.5 kW	90	99	92	101	48	49	38	39

ELECTRICAL ACCESSORIES

Disconnect	Standard Access - 0-7.5 kW	0-7.5 kW	22A20	22A20	22A20	22A20
		15 kW	22A20	22A20	22A20	22A20
		22.5 kW	22A21	22A21	22A20	22A20
	Hinged Access - 0-7.5 kW	0-7.5 kW	22A23	22A23	22A23	22A23
		15 kW	22A23	22A23	22A23	22A23
		22.5 kW	22A24	22A24	22A23	22A23

NOTE - All units have a minimum Short Circuit Current Rating (SCCR) of 5000 amps.

¹ Extremes of operating range are plus and minus 10% of line voltage.

² HACR type breaker or fuse.

³ Refer to National or Canadian Electrical Code manual to determine wire, fuse and disconnect size requirements.

ELECTRIC HEAT CAPACITIES

Input Voltage	5 kW			7.5 kW			10 kW		
	No of Stages	kW input	Btuh Output	No of Stages	kW input	Btuh Output	No of Stages	kW input	Btuh Output
208	1	3.8	12,800	1	5.6	19,200	1	7.5	25,600
220	1	4.2	14,300	1	6.3	21,500	1	8.4	28,700
230	1	4.6	15,700	1	6.9	23,500	1	9.2	31,400
240	1	5.0	17,100	1	7.5	25,600	1	10.0	34,200
440	---	---	---	1	6.3	21,500	---	---	---
460	---	---	---	1	6.9	23,500	---	---	---
480	---	---	---	1	7.5	25,600	---	---	---
550	---	---	---	1	6.3	21,500	---	---	---
575	---	---	---	1	6.9	23,500	---	---	---
600	---	---	---	1	7.5	25,600	---	---	---

Input Voltage	15 kW			22.5 kW			30 kW		
	No of Stages	kW input	Btuh Output	No of Stages	kW input	Btuh Output	No of Stages	kW input	Btuh Output
208	1	11.2	38,400	1	16.9	57,700	1	22.5	76,800
220	1	12.6	43,000	1	18.9	64,500	1	25.2	86,000
230	1	13.8	47,000	1	20.7	70,700	1	27.5	93,900
240	1	15.0	51,200	1	22.5	76,800	1	30.0	102,400
440	1	12.6	43,000	1	18.9	64,500	1	25.2	86,000
460	1	13.8	47,000	1	20.7	70,700	1	27.5	93,900
480	1	15.0	51,200	1	22.5	76,800	1	30.0	102,400
550	1	12.6	43,000	1	18.9	64,500	1	25.2	86,000
575	1	13.8	47,000	1	20.7	70,700	1	27.5	93,900
600	1	15.0	51,200	1	22.5	76,800	1	30.0	102,400

UNIT CLEARANCES

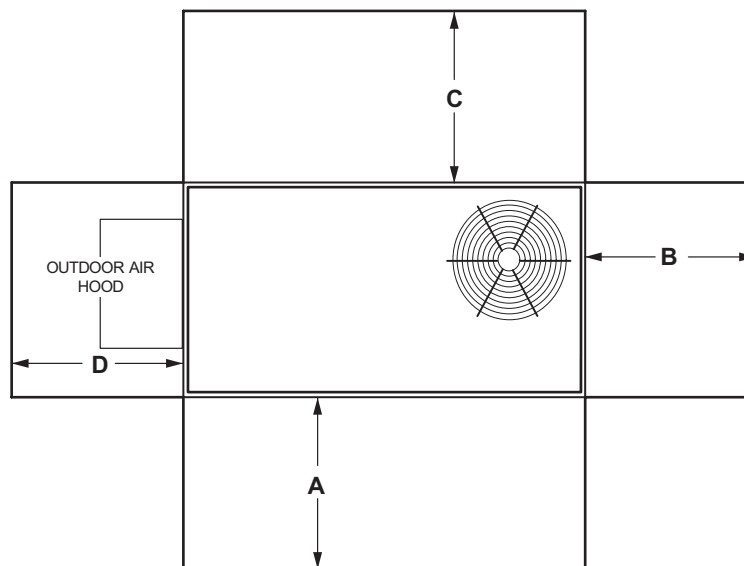

¹ Unit Clearance	A		B		C		D		Top Clearance
	in.	mm	in.	mm	in.	mm	in.	mm	
Service Clearance	36	914	36	914	36	914	36	914	Unobstructed
Minimum Operation Clearance	36	914	36	914	36	914	36	914	

NOTE - Entire perimeter of unit base requires support when elevated above the mounting surface.

¹ Service Clearance - Required for removal of serviceable parts.

Minimum Operation Clearance - Required clearance for proper unit operation.

WEIGHT DATA

Model Number	Net				Shipping			
	Base		Max.		Base		Max.	
	lbs.	kg	lbs.	kg	lbs.	kg	lbs.	kg
KHB024S	566	257	664	301	607	275	705	320
KHB024H	568	257	635	288	608	276	675	306
KHB030S	566	257	664	301	607	275	705	320
KHB036S	566	257	664	301	607	275	705	320
KHB036H	568	257	685	310	608	276	725	330
KHB048S	641	291	767	348	682	309	808	367
KHB048H	641	290	760	345	681	309	800	362
KHB060S	686	311	792	359	727	330	833	378
KHB060H	727	330	846	384	787	357	906	411
KHB074S	750	340	862	391	810	367	931	422

Base Unit - The unit with NO OPTIONS.

Max. Unit - The unit with ALL OPTIONS Installed (Economizer, etc.)

OPTIONS / ACCESSORIES

	Shipping Weights		
	lbs.	kg	
ECONOMIZER / OUTDOOR AIR / Exhaust			
Economizer			
Economizer - Includes Barometric Relief Dampers and Exhaust Hood	131	59	
Outdoor Air Dampers			
Motorized	40	18	
Manual	30	14	
Power Exhaust			
Standard Static	35	16	
ELECTRIC HEAT			
5 kW	31	14	
7.5 kW	31	14	
10 kW	31	14	
15 kW	31	14	
22.5 kW	35	16	
30 kW	35	16	
ROOF CURBS			
Hybrid Roof Curbs, Downflow			
8 in. height	50	23	
14 in. height	70	32	
18 in. height	80	36	
24 in. height	100	45	
Hybrid Curbs, Full Perimeter, Downflow			
8 in. height	57	26	
14 in. height	60	27	
18 in. height	91	41	
24 in. height	114	52	
Adjustable Pitch Curb, Downflow			
14 in. height	113	51	
CEILING DIFFUSERS			
Step-Down	RTD9-65S	80	36
	RTD11-95S	118	54
Flush	FD9-65S	80	36
	FD11-95S	118	54
Transitions (Supply and Return)	T1TRAN10AN1	22	10
	T1TRAN20N-1	21	10

DIMENSIONS - UNIT

Model No.	CORNER WEIGHTS												CENTER OF GRAVITY											
	AA		BB		CC		DD		EE		FF		Base	Max.	Base	Max.	Base	Max.	Base	Max.				
	lbs.	kg	lbs.	kg	lbs.	kg	lbs.	kg	lbs.	kg	lbs.	kg									in.	mm	in.	mm
024S	119	54	140	64	149	67	153	69	165	75	170	77	133	60	201	91	38	965	43-3/4	1111	22-1/4	565	22-1/4	565
024H	119	54	146	66	147	67	151	68	167	76	171	78	135	61	166	75	38	965	42	1067	22	559	22	559
030S	119	54	140	64	149	67	153	69	165	75	170	77	133	60	201	91	38	965	43-3/4	1111	22-1/4	565	22-1/4	565
036S	119	54	140	64	149	67	153	70	165	75	170	77	133	60	201	91	38	965	43-3/4	1111	22-1/4	565	22-1/4	565
036H	122	55	150	68	144	65	170	77	164	74	193	88	138	63	171	78	39	991	40	1016	22	559	22	559
048S	128	58	153	69	159	72	177	80	197	89	239	109	158	72	198	90	38	965	39	991	21	533	20	508
048H	137	62	167	76	163	74	188	85	185	84	215	98	156	71	190	86	38	965	42	1067	22	559	22	559
060S	137	62	158	72	170	77	175	79	210	95	236	107	169	77	223	101	38	965	41	1041	21	533	20	508
060H	162	73	217	98	192	87	201	91	218	99	229	104	184	83	247	112	45	1143	51	1295	22	559	22	559
074S	160	73	185	84	180	82	208	94	233	106	269	122	207	94	239	108	46-1/4	1174	46-1/4	1174	20-1/2	521	20-1/2	521

Base Unit - The unit with standard heat exchanger NO OPTIONS.
 Max. Unit - The unit with ALL OPTIONS Installed (Economizer, etc.).

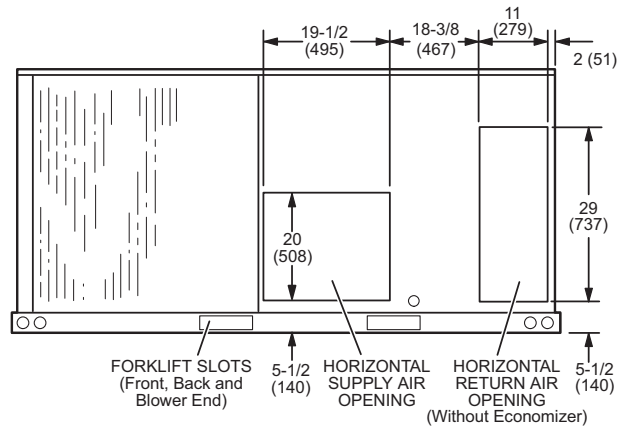
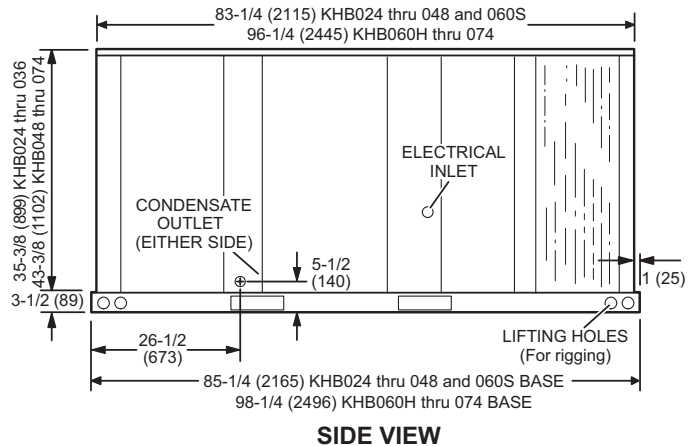
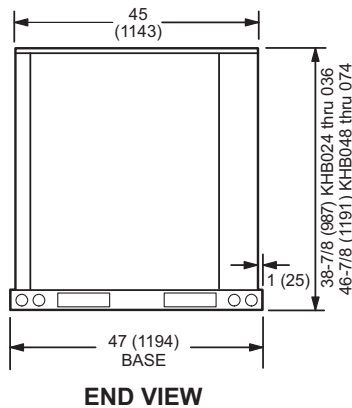
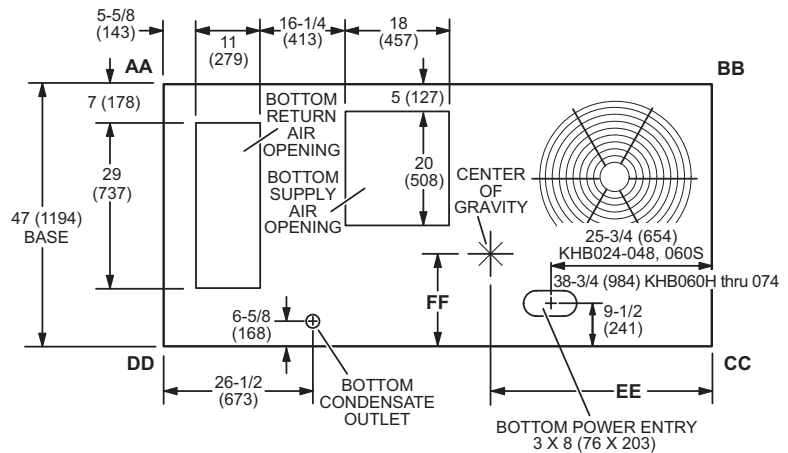

DIMENSIONS - ACCESSORIES

COMBINATION OUTDOOR AIR HOOD DETAIL FOR OPTIONAL ECONOMIZER AND BAROMETRIC RELIEF DAMPERS (Furnished With Economizer for Downflow Applications)

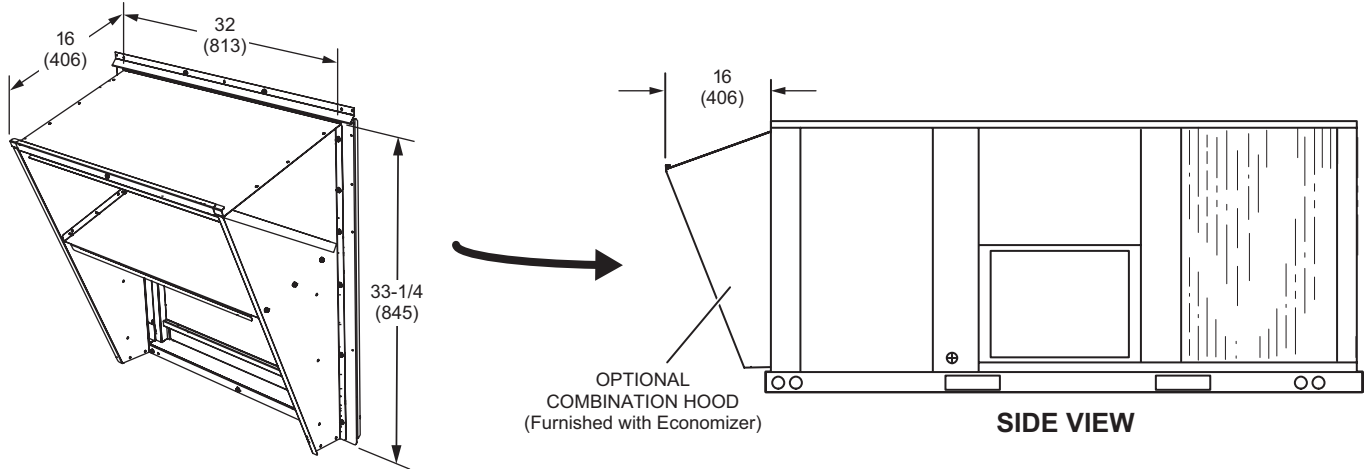

OUTDOOR AIR DAMPER HOOD DETAIL (Downflow or Horizontal Applications)

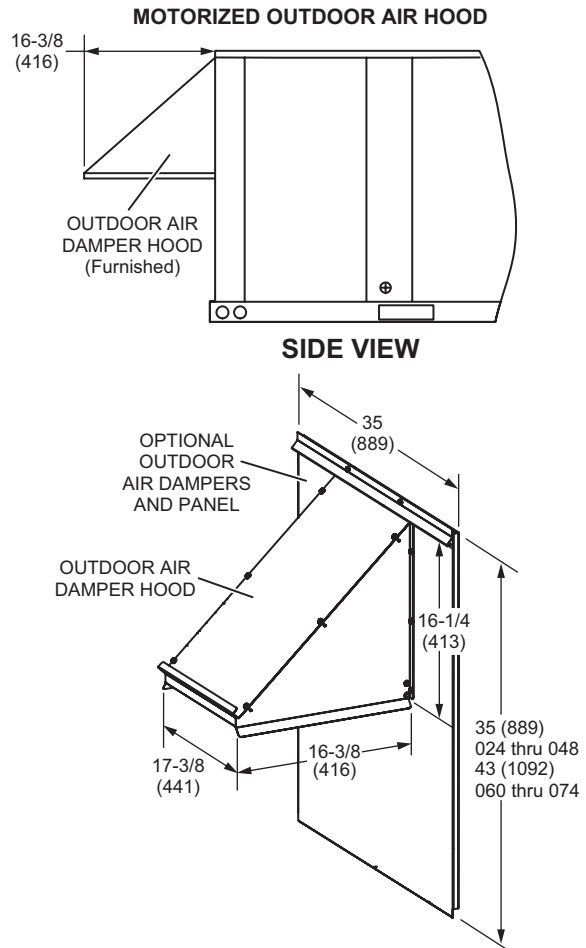
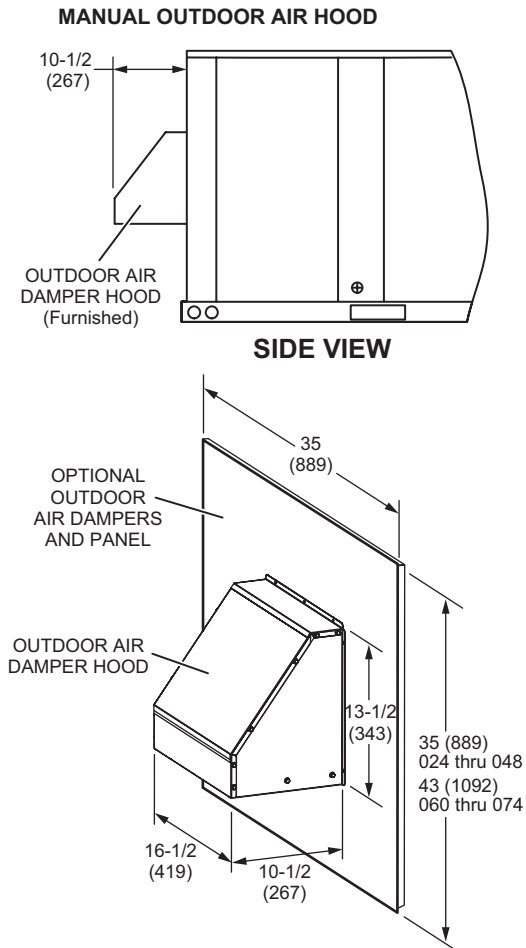

DIMENSIONS - ACCESSORIES

OUTDOOR AIR HOOD DETAIL WITH OPTIONAL ECONOMIZER AND OPTIONAL BAROMETRIC RELIEF DAMPERS WITH HOOD (Horizontal Application)

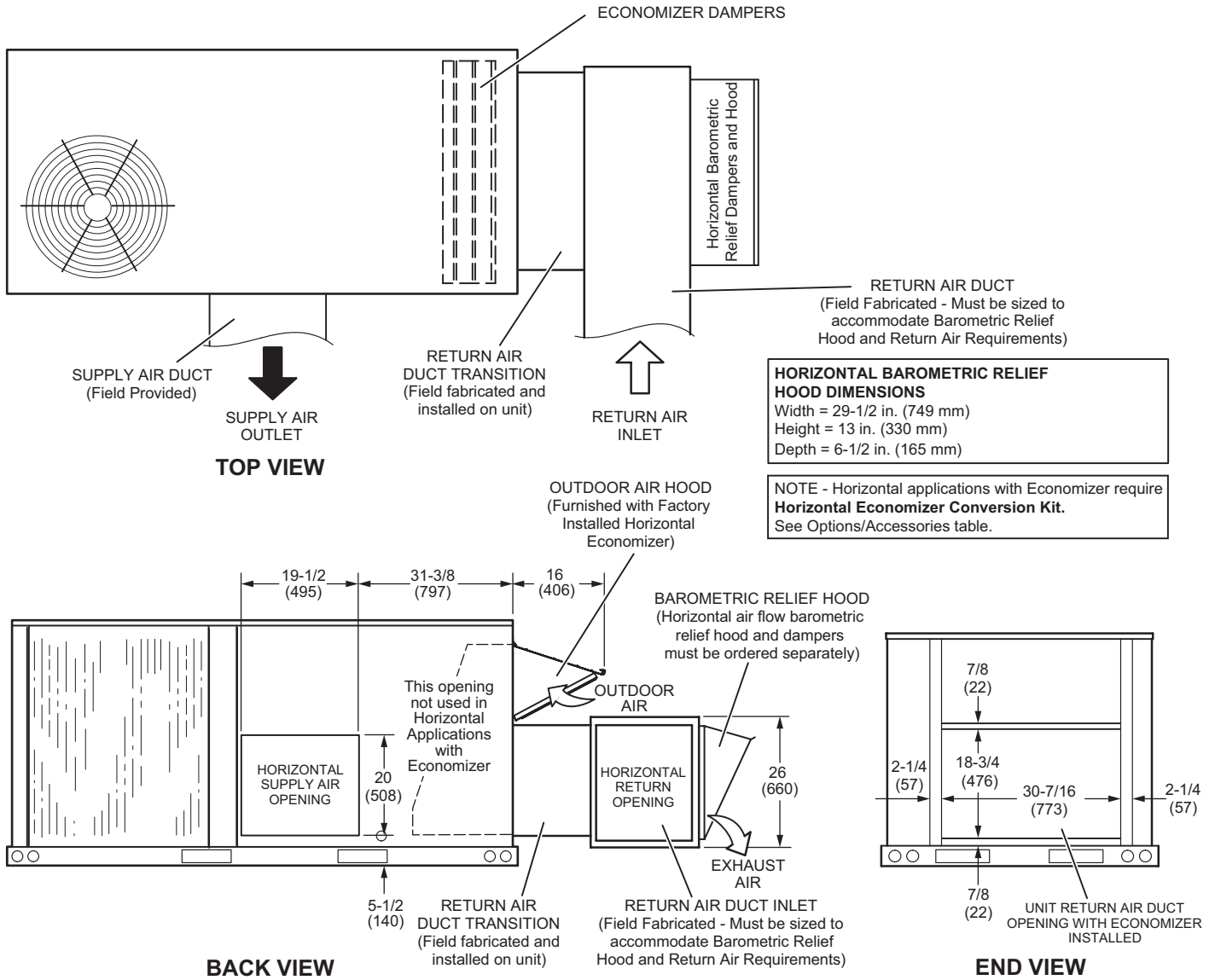

NOTE - Return Air Duct and Transition must be supported

DIMENSIONS - ACCESSORIES

HYBRID ROOF CURBS - DOUBLE DUCT OPENING - STANDARD AND FULL PERIMETER

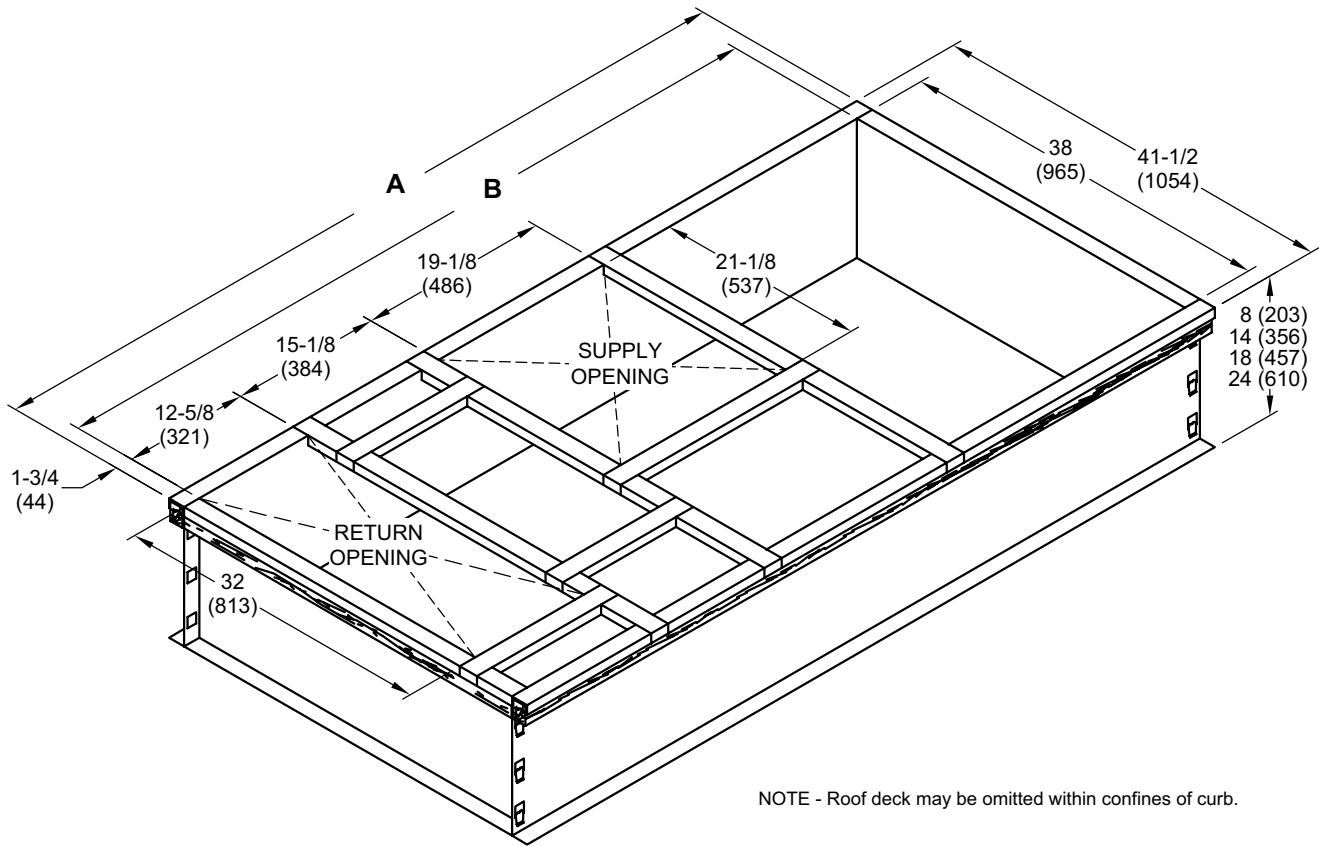

TYPICAL FLASHING DETAIL FOR ROOF CURB

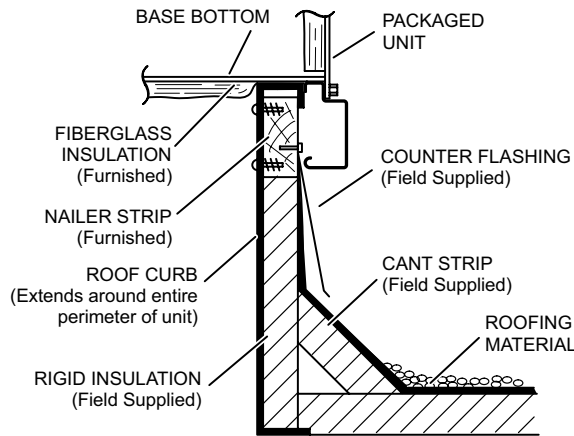

DETAIL ROOF CURB

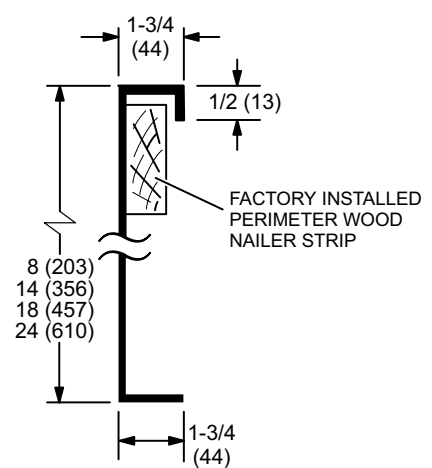

Model No.	A		B	
	in.	mm	in.	mm
Standard - 024, 030, 036, 048, 060S, ¹ 060H, ¹ 074	79-3/4	2026	76-1/4	1937
Full Perimeter - 060H, 074	92-3/4	2356	89-1/4	2267

¹ 060H and 074 models can be used on smaller 79-3/4 in. (2026 mm) roof curbs (not full perimeter) with 15-3/4 in. (400 mm) overhang at condenser end of unit. See dimension drawing on page 61.

DIMENSIONS - ACCESSORIES

ADJUSTABLE PITCH CURBS - DOUBLE DUCT OPENING

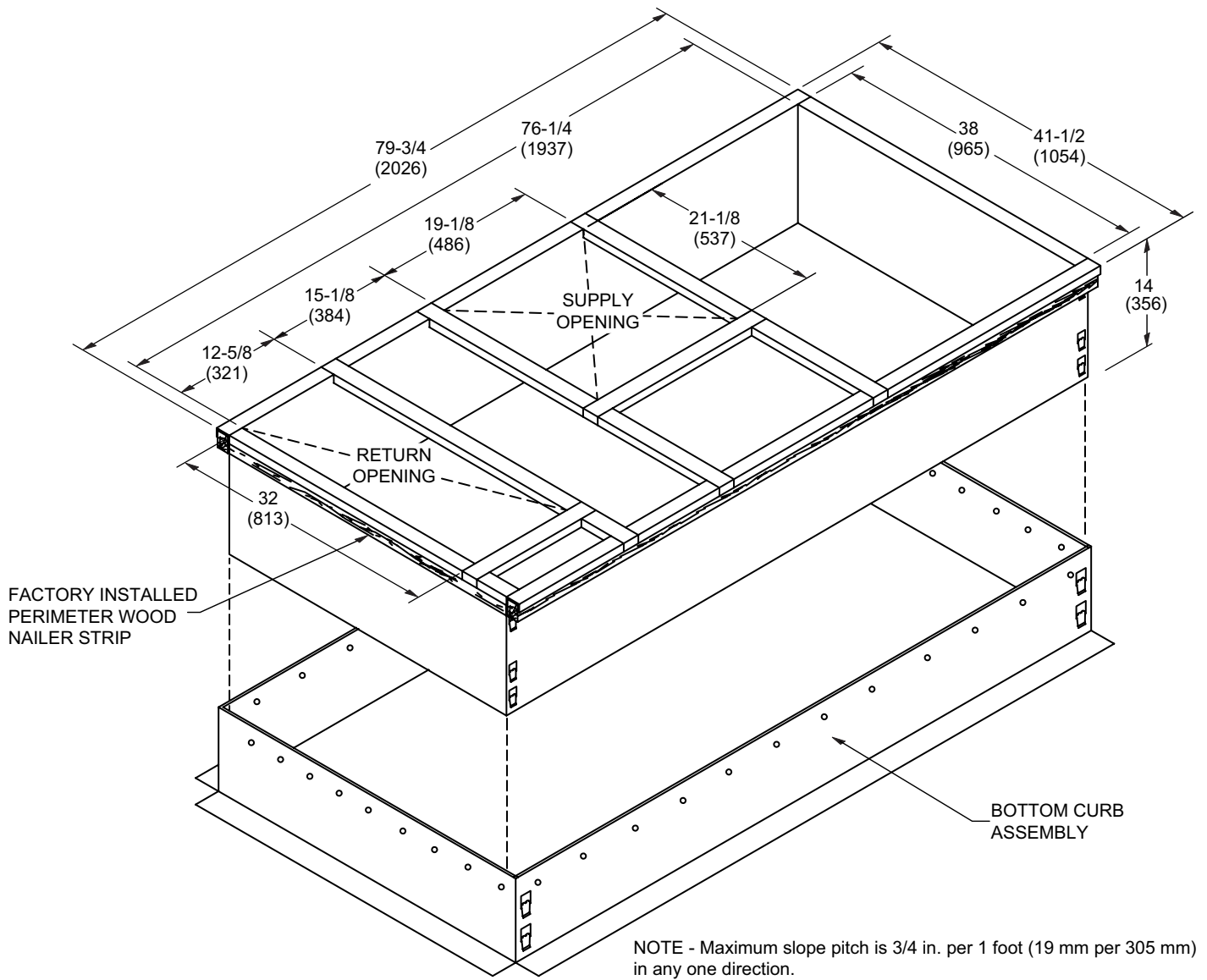

TYPICAL FLASHING DETAIL FOR ROOF CURB

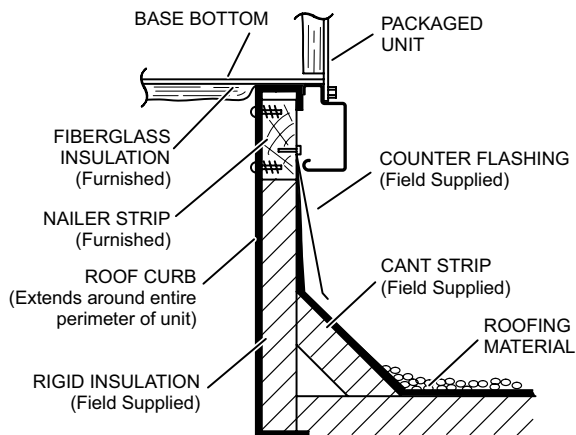

DETAIL ROOF CURB

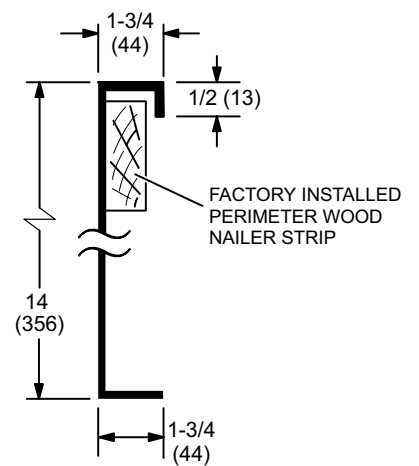

DIMENSIONS - ACCESSORIES

060H AND 074 MODELS - SHOWING OVERHANG ON SMALLER 79-3/4 INCH LENGTH ROOF CURBS
(Not Full Perimeter)

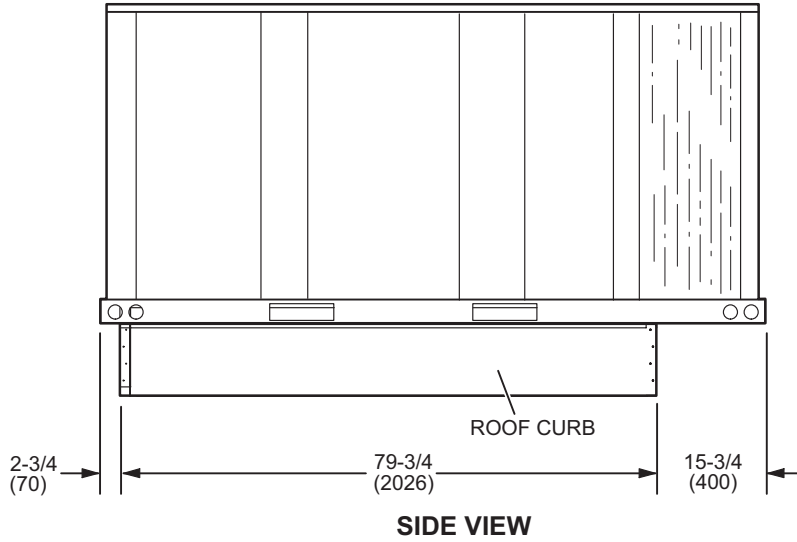

TRANSITIONS

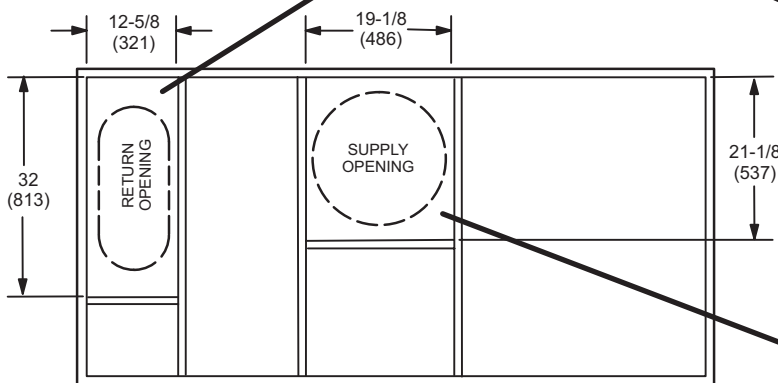

T1TRAN10AN-1 - FOR 18 INCH (457 MM) DUCT
T1TRAN20N-1 - FOR 20 INCH (508 MM) DUCT

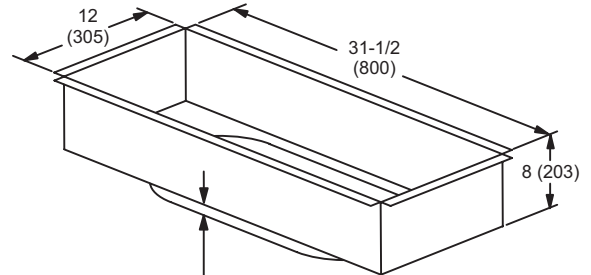

1-1/2 inch (38 mm) T1TRAN10AN-1
2 inch (51mm) T1TRAN20N-1

RETURN TRANSITION

T1TRAN10AN-1 - FOR 18 INCH (457 MM) DUCT
T1TRAN20N-1 - FOR 20 INCH (508 MM) DUCT

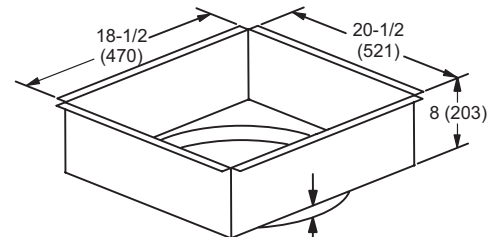

1-1/2 inch (38 mm) T1TRAN10AN-1
2 inch (51mm) T1TRAN20N-1

SUPPLY TRANSITION

DIMENSIONS - ACCESSORIES

COMBINATION CEILING SUPPLY AND RETURN DIFFUSERS

STEP-DOWN CEILING DIFFUSER

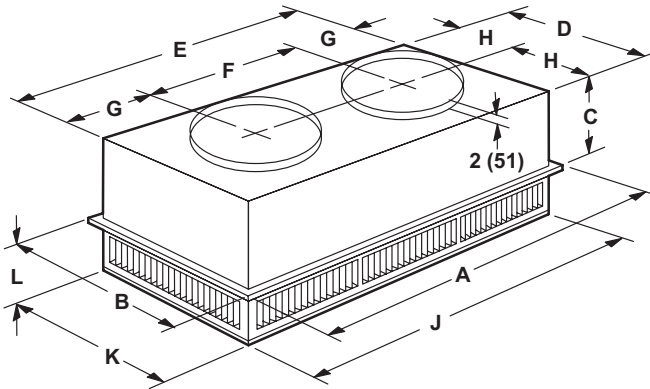

FLUSH CEILING DIFFUSER

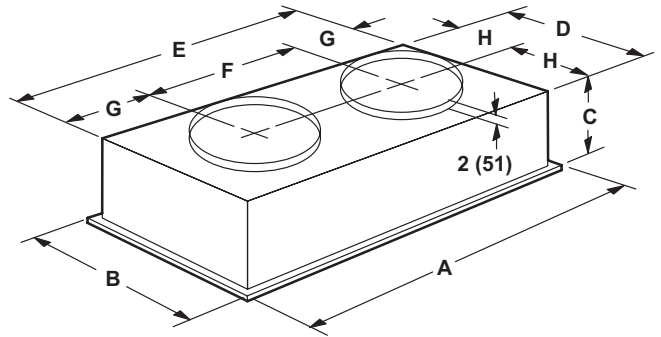

Model Number		RTD9-65S	RTD11-95S
A	in.	47-5/8	47-5/8
	mm	1159	1159
B	in.	23-5/8	29-5/8
	mm	600	752
C	in.	11-3/8	14-3/8
	mm	289	365
D	in.	21-1/2	27-1/2
	mm	546	699
E	in.	45-1/2	45-1/2
	mm	1156	1158
F	in.	22-1/2	22-1/2
	mm	572	572
G	in.	11-1/2	11-1/2
	mm	292	292
H	in.	10-3/4	13-3/4
	mm	273	349
J	in.	45-1/2	45-1/2
	mm	1156	1156
K	in.	21-1/2	27-1/2
	mm	546	699
L	in.	7-1/8	8-1/8
	mm	181	206
Duct Size	in.	18 round	20 round
	mm	457 round	508 round

Model Number		FD9-65S	FD11-95S
A	in.	47-5/8	47-5/8
	mm	1159	1159
B	in.	23-5/8	29-5/8
	mm	600	752
C	in.	13-1/2	16-5/8
	mm	343	422
D	in.	21	27
	mm	533	686
E	in.	45	45
	mm	1143	1143
F	in.	22-1/2	22-1/2
	mm	572	572
G	in.	11-1/4	11-1/4
	mm	286	286
H	in.	10-1/2	13-1/2
	mm	267	343
Duct Size	in.	18 round	20 round
	mm	457 round	508 round

REVISIONS

Sections	Description of Change
Options/Accessories	Added step-down transformers for UVC lights. Catalog numbers revised for: Barometric Relief Dampers Condensate Drain Trap Disconnects Economizers Power Exhaust Single Enthalpy Smoke Detectors



Visit us at www.Lennox.com

For the latest technical information, www.LennoxCommercial.com

Contact us at 1-800-4-LENNOX

NOTE - Due to Lennox' ongoing commitment to quality, Specifications, Ratings and Dimensions subject to change without notice and without incurring liability. Improper installation, adjustment, alteration, service or maintenance can cause property damage or personal injury. Installation and service must be performed by a qualified installer and servicing agency.

©2021 Lennox Industries, Inc.