

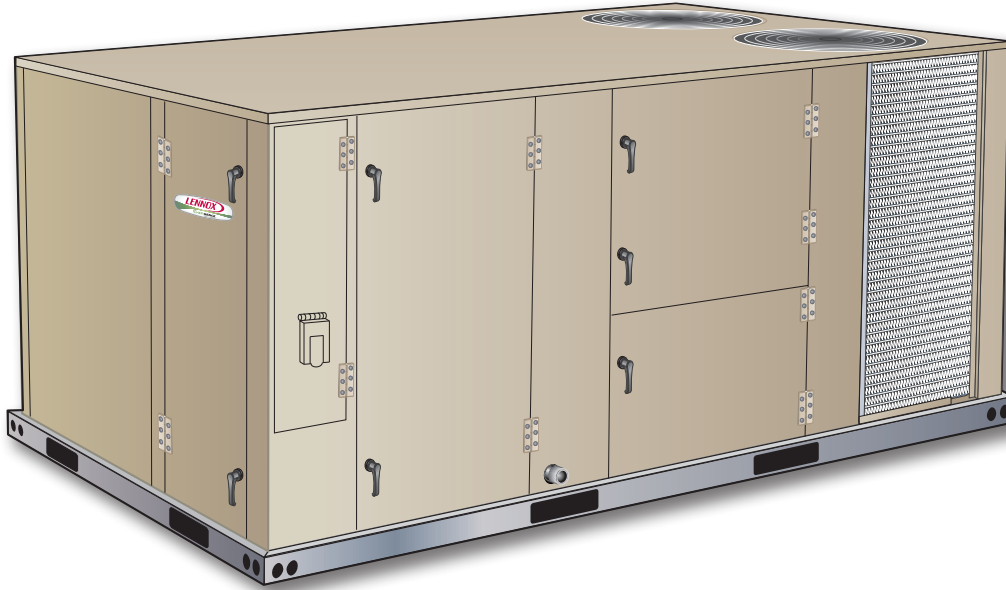

LCH
Energence® Rooftop Units
60 Hz

**COMMERCIAL
 PRODUCT SPECIFICATIONS**

Bulletin No. 210556
 February 2020
 Supersedes January 2020



7.5 to 12.5 Tons
Net Cooling Capacity - 90,000 to 138,000 Btuh
Optional Electric Heat - 7.5 to 60 kW

MODEL NUMBER IDENTIFICATION

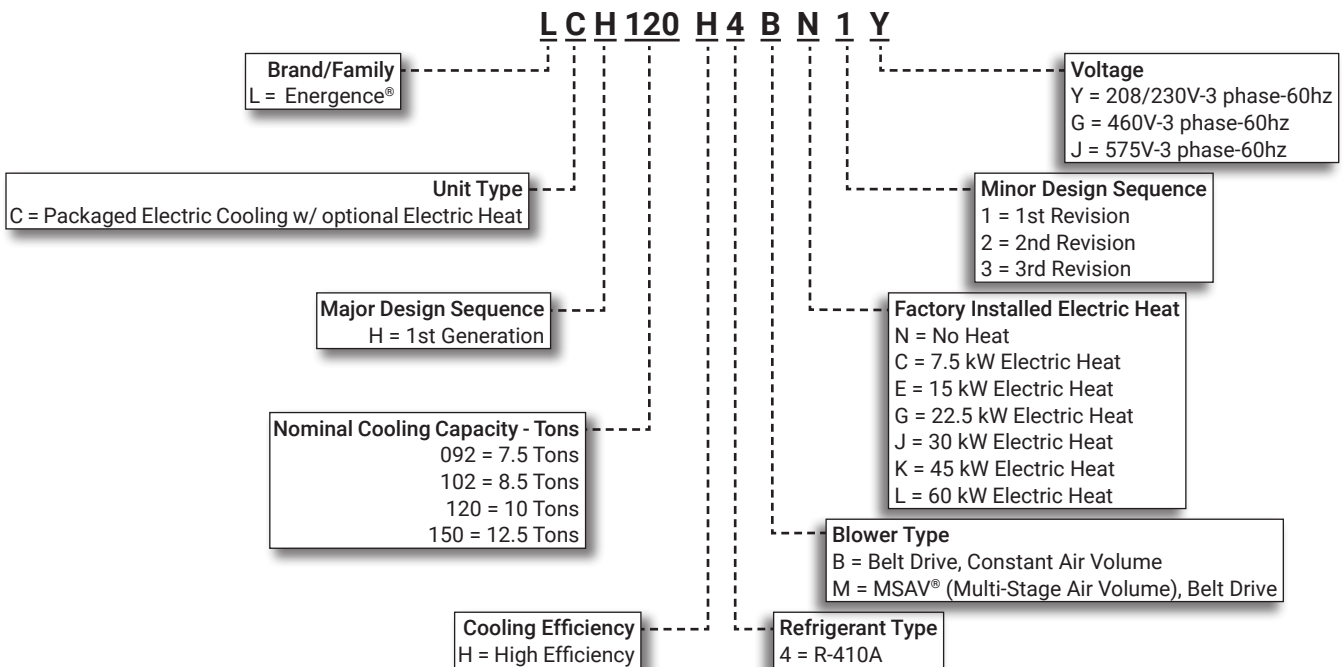

FEATURE HIGHLIGHTS

Lennox' Energence® packaged rooftop unit product line was created to save energy with intelligence by offering some of the highest energy efficiency ratings available with a powerful, easy to use unit controller. This makes Energence rooftop units perfect for business owners looking for an HVAC product with the lowest total cost of ownership.

1. Scroll Compressors
2. Lennox' Environ™ Coil System
3. Outdoor Coil Fan Motors
4. Heavy Gauge Steel Cabinet
5. Hinged Access Panels
6. Constant or Multi-Stage Air Volume (MSAV®) Blower
7. Variable Frequency Drive (VFD)
8. Electric Heat (option)
9. GFI Service Outlets (option)
10. Air Filters
11. Prodigy® Control System
12. Economizer (option)
13. Downflow Barometric Relief Dampers (option)

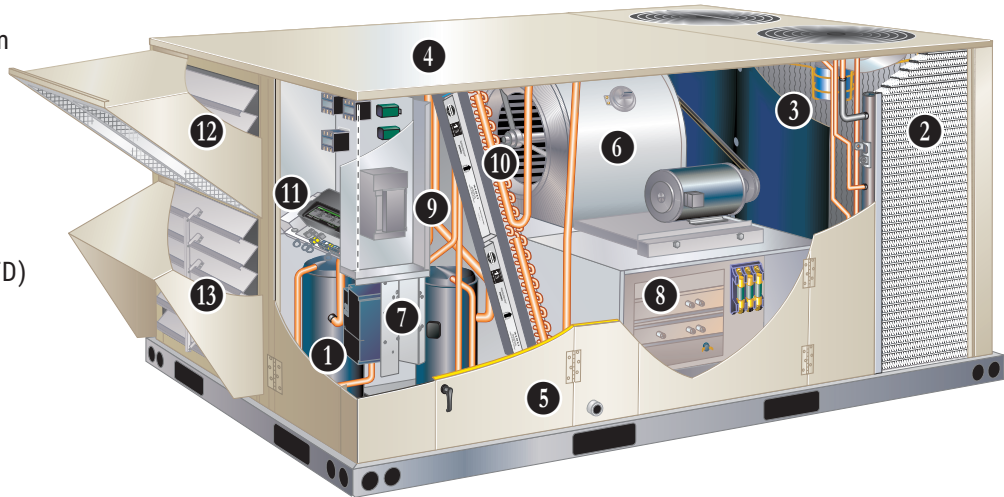

CONTENTS

Approvals and Warranty	3
Blower Data	30
Control System	8
Dimensions - Accessories	41
Dimensions - Unit	40
Electrical/Electric Heat Data	34
Features And Benefits	3
Humiditrol® Dehumidification System Option	12
Humiditrol® Dehumidification System Ratings	28
Model Number Identification	1
Optional Conventional Temperature Control Systems	13
Options / Accessories	18
Outdoor Sound Data	38
Ratings	24
Sequence Of Operation	15
Specifications	22
Unit Clearances	38
Weight Data	39

APPROVALS AND WARRANTY

APPROVALS

- AHRI Standard 340/360 certified
- ETL and CSA listed
- CSA certified energy ratings
- Unit and components ETL, NEC and CEC bonded for grounding to meet safety standards for servicing
- All models are ASHRAE 90.1-2010 energy efficiency compliant and meet or exceed requirements of Section 6.8
- All models meet DOE 2018 energy efficiency standards
- MSAV models meet California Code of Regulations, Title 24 and ASHRAE 90.1-2010 Section 6.4.3.10 requirements for staged airflow
- ENERGY STAR® certified
- ISO 9001 Registered Manufacturing Quality System

WARRANTY

- Compressors - Limited five years
- Lennox' Environ™ Coil System - Limited three years
- Prodigy® 2.0 Unit Controller - Limited three years
- High Performance Economizers (optional) - Limited five years
- All other covered components - Limited one year

FEATURES AND BENEFITS

COOLING SYSTEM

- Designed to maximize sensible and latent cooling performance at design conditions
- System can operate from 0°F to 125°F without any additional controls

R-410A Refrigerant

- Non-chlorine based
- Ozone friendly

1 Scroll Compressors

- Scroll compressors on all models for high performance, reliability and quiet operation
- Resiliently mounted on rubber grommets for quiet operation

Compressor Crankcase Heaters

- Protects against refrigerant migration that can occur during low ambient operation or during extended off cycles

Thermal Expansion Valves

- Assures optimal performance throughout the application range
- Removable element head

Filter/Driers

- High capacity filter/drier protects the system from dirt and moisture

High Pressure Switches

Protects the compressor from overload conditions such as dirty condenser coils, blocked refrigerant flow, or loss of outdoor fan operation

Low Pressure Switches

- Protects the compressors from low pressure conditions such as low refrigerant charge, or low/no airflow

Freezestats

- Protects the evaporator coil from damaging ice build-up due to conditions such as low/no airflow, or low refrigerant charge

2 Condenser Coil - Lennox' Environ™ Coil System (092 through 120 models only)

- Lightweight, all aluminum brazed fin construction
- Constructed of three components
 - A flat extrusion tube
 - Fins in-between the flat extrusion tube
 - Two refrigerant manifolds

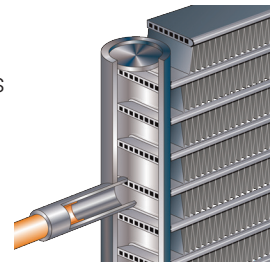

Environ™ Coil System Features:

- Improved heat transfer performance due to high primary surface area (flat tubes) versus secondary surface (fins)
- Smaller internal volume (reduced refrigerant charge)
- High durability
- All aluminum construction
- Fewer brazed joints
- Compact design
- Reduced unit weight
- Easy maintenance/cleaning
- Face split design
- Mounting brackets with rubber inserts

FEATURES AND BENEFITS

COOLING SYSTEM (continued)

Conventional Fin/Tube Condenser Coils (150 models only, optional 092-120 models)

- Copper tube construction
- Enhanced rippled-edge aluminum fins
- Flared shoulder tubing connections
- Silver soldered construction

Evaporator Coil

- Copper tube construction
- Enhanced rippled-edge aluminum fins
- Flared shoulder tubing connections
- Silver soldered construction
- Factory leak tested
- Cross row circuiting with rifled tubing

Condensate Drain Pan

- Plastic pan, sloped to meet drainage requirements per ASHRAE 62.1
- Side or bottom drain connections
- Reversible to allow connection at back of unit

3 Outdoor Coil Fan Motors

- Thermal overload protected
- Totally enclosed
- Permanently lubricated ball bearings
- Shaft up
- Wire basket mount

Outdoor Coil Fans

- PVC coated fan guard furnished

Required Selections

Cooling Capacity

- Specify nominal cooling capacity

Options/Accessories

Factory Installed

Conventional Fin/Tube Condenser Coil (replaces Environ Coil System - 092 through 120 models only)

- Copper tube construction
- Enhanced rippled-edge aluminum fins
- Flared shoulder tubing connections
- Silver soldered construction

NOTE - All 150 models have a fin/tube coil as standard.

Service Valves

- Fully serviceable brass valves installed in discharge & liquid lines

NOTE - Not available for units equipped with Environ Coil System or Humiditrol Dehumidification option.

Factory or Field Installed

Condensate Drain Trap

- Available in copper or PVC
- Field installed only, may be factory ordered to ship with unit

Drain Pan Overflow Switch

- Monitors condensate level in drain pan
- Shuts down unit if drain becomes clogged

CABINET

4 Construction

- Heavy-gauge steel panels
- Full perimeter heavy-gauge galvanized steel base rail
- Base rails have rigging holes
- Three sides of the base rail have forklift slots
- Raised edges around duct and power entry openings in the bottom of the unit for water protection

Airflow Choice

- Units are shipped in downflow (vertical) return air flow configuration

NOTE - Units can be field converted to horizontal airflow with optional Horizontal Discharge Kit.

Duct Flanges

- Provided for horizontal duct attachment

Power Entry

- Electrical lines can be brought through the unit base or through horizontal access knock-outs

Exterior Panels

- Constructed of heavy-gauge, galvanized steel
- Two-layer enamel paint finish

Insulation

- Fully insulated with non-hygroscopic fiberglass insulation (conditioned areas)
- Unit base is fully insulated
- Base insulation serves as an air seal to the roof curb, eliminating the need to add a seal during installation

5 Hinged Access Panels

- Tool-less access
- Filter section
- Blower/heating section
- Compressor/controls section
- Panel seals and quarter-turn latching handles provide a tight air and water seal

Required Selections

Airflow Configuration

- Specify downflow or horizontal

FEATURES AND BENEFITS

CABINET (continued)

Options/Accessories

Factory or Field Installed

Return Air Adaptor Plate

- For same size LC/LG/LH and TC/TG/TH unit replacement
- Installs on return air opening in unit to match return air opening on existing roof curbs
- Also see Accessory Air Resistance table

Factory Installed

Corrosion Protection

- Completely flexible immersed coating
- Electrodeposited dry film process
- AST ElectroFin E-Coat
- Meets Mil Spec MIL-P-53084, ASTM B117 Standard Method Salt Spray Testing
- Indoor Corrosion Protection:
 - Coated coil
 - Coated reheat coil (Humiditrol®)
 - Painted blower housing
 - Painted base
- Outdoor Corrosion Protection:
 - Coated coil
 - Painted outdoor base

Field Installed

Combination Coil/Hail Guards

- Heavy gauge steel frame
- Painted to match cabinet
- Expanded metal mesh protects outdoor coil

Horizontal Discharge Kit

- Consists of duct covers to block off downflow supply and return air openings for horizontal applications
- Also includes return air duct flanges for end return air when economizer is used in horizontal applications

NOTE - When configuring unit for horizontal application with economizer, a separate Horizontal Barometric Relief Damper with Hood must be ordered separately for installation in the return air duct.

BLOWER

A wide selection of supply air blower options are available to meet a variety of airflow requirements

Motor

- Overload protected
- Ball bearings
- Belt drive motors are offered on all models and are available in several different sizes to maximize air performance

NOTE - All blower motors 5 hp and above meet minimum energy efficiency standards in accordance with the Energy Independence and Security Act (EISA) of 2007.

Supply Air Blower

- Forward curved blades
- Double inlet
- Blower wheel statically and dynamically balanced
- Ball bearings
- Adjustable pulley (allows speed change)
- Blower assembly slides out of unit for servicing

Required Selections

6 Select Constant Air Volume (CAV) or MSAV® (Multi-Stage Air Volume) Supply Air Blower Option

- Constant Air Volume (CAV) models supply a constant volume of air
- MSAV (Multi-Stage Air Volume) models stage the amount of airflow according to compressor stages, heating demand, ventilation demand or smoke alarm

NOTE - Units with the MSAV supply air blower option have the same face split indoor coils as units with the CAV supply air blower option. Part load airflow in cooling mode on MSAV units should not be set below 220 cfm/nominal full load ton to reduce the risk of evaporator coil freeze-up.

- 7** • Utilizes a Variable Frequency Drive (VFD) to stage the supply blower airflow
 - VFD alters the frequency and voltage of the power supply to the blower to control blower speed
 - The amount of airflow for each stage can be set according to a parameter in the Prodigy® 2.0 unit controller
 - Unit is shipped from the factory with preset airflow
 - MSAV® can be ordered with or without an Electronic Bypass Control
 - If equipped with the bypass control the MSAV® features manual (default) or automatic electronic bypass control of the VFD
 - In case of a VFD malfunction, a VFD alarm is generated by the Prodigy® 2.0 unit controller
 - VFD can be manually bypassed to continue unit operation at full blower speed
 - Or the unit controller can be set to automatically switch to full blower speed if a VFD alarm is generated
 - VFD has an operational range of 0 to 125°F outdoor air ambient temperature

- Lower operating costs are obtained when the blower is operated on lower speeds

Ordering Information

- Specify motor horsepower and drive kit number when base unit is ordered

Options/Accessories

Factory Installed

Blower Belt Auto-Tensioner

- Provides proper tension to belt drive blower belt without the need for regular adjustments
- Maintains airflow and proper performance

FEATURES AND BENEFITS

ELECTRICAL

SmartWire™ System

- Keyed and color-coded wiring connectors prevent miswiring
- Wire coloring scheme is standardized across all models
- Each connection is intuitively labeled to make troubleshooting and servicing quick and easy

Electrical Plugs

- Positive connection electrical plugs are used to connect common accessories or maintenance parts for easy removal or installation

Required Selections

Voltage Choice

- Specify when ordering base unit

Options/Accessories

Factory Installed

Circuit Breakers

- HACR type
- For overload and short circuit protection
- Factory wired and mounted in the power entry panel
- Current sensitive and temperature activated
- Manual reset

SCR (Silicon Controlled Rectifier) Electric Heat Control

- Modulates small, precise increments of power to the electric heat load eliminating temperature fluctuations associated with mechanical controls
- Almost instantaneous operation with no moving parts
- Zero-Cross (fast cycling) feature improves electric heater life with less contraction and expansion of the heating elements
- The SCR operates when there is no call for heat from the building control system or thermostat
- SCR air tempering is controlled by a secondary thermostat and remote duct sensor (ordered separately)
- A call for heat overrides the SCR and modulates the SCR to 100% heat output. A call for cooling overrides the SCR

NOTE - The SCR option is not available with 45 kW and 60 kW electric heat (208/230V) models.

NOTE - Blower Proving Switch is required and must be ordered separately for factory installation. See Controls in the Options/Accessories table.

NOTE - Available for use with conventional thermostat controls or Novar® control systems only.

Short-Circuit Current Rating (SCCR)

- Higher short-circuit protection up to 100kA

NOTE - Disconnect Switch is not available as an option with High SCCR option.

Phase/Voltage Detection (Optional for CAV Models Only)

- Monitors power supply to assure phase is correct at unit start-up
- If phase is incorrect, the unit will not start and an alarm code is reported to the unit controller
- Protects unit from being started with incorrect phasing which could lead to issues such as compressors running backwards
- Voltage detection monitors power supply voltage to assure proper voltage
- If voltage is not correct (over/under voltage conditions) the unit will not start and an alarm code is reported to the unit controller

NOTE - Phase/voltage detection is furnished when the MSAV (Multi-Stage Air Volume) option is ordered.

Factory or Field Installed

Disconnect Switch

- Accessible outside of unit
- Spring loaded weatherproof cover furnished

8 Electric Heat

- Helix wound nichrome elements
- Individual element limit controls
- Wiring harness
- Unit fuse block
- See Options / Accessories tables for ordering information

9 GFI Service Outlets (2)

- 115V ground fault circuit interrupter (GFCI) type
- Non-powered
- Field-wired

Field Installed

GFI Weatherproof Cover

- Single-gang cover
- Heavy-duty UV-resistant polycarbonate case construction
- Hinged base cover with gasket

FEATURES AND BENEFITS

INDOOR AIR QUALITY

10 Air Filters

- Disposable 2-inch filters furnished as standard

Options/Accessories

Factory or Field Installed

Healthy Climate® High Efficiency Air Filters

- Disposable MERV 8 or MERV 13 (Minimum Efficiency Reporting Value based on ASHRAE 52.2) efficiency 2 inch pleated filters

Replacement Filter Media Kit With Frame

- Replaces existing pleated filter media
- Includes washable metal mesh screen and metal frame with clip for holding replaceable non-pleated filter

Field Installed

Healthy Climate® UVC Germicidal Light Kit

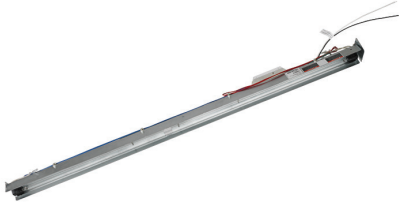

- Germicidal lamps emit ultra-violet (UV-C) energy, which has been proven to be effective in reducing microbes such as viruses, bacteria, yeasts, and molds
 - This process either destroys the organism or controls its ability to reproduce
 - UV-C energy greatly reduces the growth and proliferation of mold and other bioaerosols (bacteria and viruses) on illuminated surfaces (particularly coil and drain pan)
 - Field installed in the blower/evaporator coil section
 - All necessary hardware for installation is included.
 - Lamps operate on 110/230V, 1 phase power supply
- NOTE** - Step-down transformer must be field supplied when used with 460V and 575V rooftop units.
- Approved by ETL

Indoor Air Quality (CO₂) Sensors

- Monitors CO₂ levels, reports to the Prodigy® 2.0 unit controller which adjusts economizer dampers as needed

CONTROL SYSTEM

PRODIGY® CONTROL SYSTEM



11 The Prodigy 2.0 unit controller is a microprocessor-based controller that provides flexible control of all unit functions.

Features:

- LCD Display
- Easy to read menu (4 lines x 20 character display)
- Buttons for menu navigation during setup and diagnostic
- Menu navigation LEDs for Data, Setup, Service, Settings
- Main Menu and Help Buttons for quick navigation to home screen and built-in help functions
- Scroll, Value Adjustment Select and Save Buttons
- Setup menu insures proper installation and simplified setup of the rooftop unit
- Profile setup copies key settings between units with the same configuration to reduce setup time
- USB port allows a technician to download and transfer unit information to help verify service was performed
- USB software updates on the Prodigy Control System enhance functionality without the need to change components
- Unit Controller Software
- Unit self-test verifies individual critical component and system performance
- Economizer test function assures economizer is operating correctly
- Time Clock with Run-Time Information

Built-In Functions Include:

- Adjustable Blower On/Off Delay
- Built-in Control Parameter Defaults
- Compressor Time-Off Delay
- DDC Compatible
- Dirty Filter Switch Input
- Discharge Air Temperature Control
- Display/Sensor Readout
- Economizer Control Options (See Economizer / Exhaust Air / Outdoor Air sections)
- Fresh Air Tempering
- Over 100 diagnostic and status messages in English
- Exhaust Fan Control Modes for fresh air damper position
- Permanent Diagnostic Code Storage
- Field Adjustable Control Parameters (Over 200 settings)
- Indoor Air Quality Input (Demand Control Ventilation)
- Low Ambient Controls for cooling operation down to 0°F

- Gas Valve Time Delay Between First and Second Stage
- Minimum Compressor Run Time
- Network Capable (Can be daisy chained to other units or controls)
- Night Setback Mode
- Return Air Temperature Limit Control
- Safety Switch Input allows Controller to respond to a external safety switch trip
- Service Relay Output
- Smoke Alarm Mode has four choices (unit off, positive pressure, negative pressure, purge)
- Up to 2 heat/2 cool (standard Prodigy unit controller thermostat input)
- Up to 3 cool with additional relay
- Up to 4 cool with room sensor or network operation
- "Strike Three" Protection
- Gas Reheat Control allows simultaneous heating and cooling operation for humidity control of process air applications such as supermarkets
- On Demand Dehumidification monitors and controls condenser hot gas reheat operation with Humiditrol® dehumidification option
- Thermostat Bounce Delay
- Warm Up Mode Delay
- LED Indicators
- PC Interface connects the Prodigy 2.0 unit controller to a PC with the Lennox Unit Controller Software
- Room Sensor Operation controls temperature

NOTE - Prodigy Control System features shown vary with the type of rooftop unit the control is installed in.

NOTE - See separate Prodigy Control System Product Specifications Bulletin for additional information.

CONTROL SYSTEM

PRODIGY® CONTROL SYSTEM (continued)

Controls Options

Factory or Field Installed

Blower Proving Switch

- Monitors blower operation, shuts down unit if blower fails

Dirty Filter Switch

- Senses static pressure increase indicating dirty filter condition

Fresh Air Tempering

- Used in applications with high outside air requirements
- Controller energizes the first stage heat as needed to maintain a minimum supply air temperature for comfort, regardless of the thermostat demand
- When ordered as a factory option, sensor ships with the unit for field installation

Smoke Detector

- Photoelectric type
- Installed in supply air section, return air section or both sections
- Available with power board and single sensor (supply or return) or power board and two sensors (supply and return)
- Power board located in unit control compartment

Interoperability via BACnet® or LonTalk® Protocols

- Communication compatible with third-party automation systems that support the BACnet Application Specific Controller device profile, LonMark® Space Comfort Controller functional profile, or LonMark Discharge Air Controller functional profile

Commercial Control Systems

L Connection® Network Control System

- Complete building automation control system for single or multi-zone applications
- Options include local interface, software for local or remote communication, and hardware for networking other control functions
- See L Connection Network Control System Product Specifications Bulletin for details

After-Market DDC

- Novar® Unit Controller and options

Thermostats

- Control system and thermostat options
- After-Market unit controller options

Field Installed

General Purpose Control Kit

- Plug-in control provides additional analog and digital inputs/outputs for field installed options

Humidity Sensor Kit

- Humidity sensor required with factory installed Humiditrol® dehumidification option or Supermarket reheat field selectable option

OPTIONS / ACCESSORIES

ECONOMIZER

- Economizer operation is set and controlled by the Prodigy 2.0 unit controller
- Simple plug-in connections from economizer to unit controller for easy installation
- All Emergence rooftop units are equipped with factory installed CEC Title 24 approved sensors for outside, return and discharge air temperature monitoring

NOTE - Optional sensors may be used instead of unit sensors to determine whether outdoor air is suitable for free cooling See Options/Accessories table

Factory or Field Installed

12 High Performance Economizer

- Approved for California Title 24 building standards
- Low leakage dampers are Air Movement and Control Association International (AMCA) Class 1A Certified - Maximum 3 CFM per sq. ft. leakage at 1 in. w.g.
- ASHRAE 90.1-2010 compliant
- Downflow or Horizontal with Outdoor Air Hood
- Outdoor Air Hood is included when economizer is factory installed and is furnished with economizer when ordered for field installation
- Downflow Barometric Relief Dampers with Exhaust Hood is also furnished
- Gear-driven action
- High torque 24-volt fully-modulating spring return damper motor
- Return air and outdoor air dampers
- Plug-in connections to unit
- Stainless steel bearings
- Enhanced neoprene blade edge seals
- Flexible stainless steel jamb seals

NOTE - High Performance Economizers are not approved for use with enthalpy controls in Title 24 applications.

NOTE - The Free Cooling setpoint for Title 24 applications must be set based on the Climate Zone where the system is installed. See Section 140.4 "Prescriptive Requirements for Space Conditioning Systems" of the California Energy Commission's 2013 Building Energy Efficiency Standards.

NOTE - Refer to Installation Instructions for complete setup information.

OPTIONS / ACCESSORIES

ECONOMIZER (continued)

Differential Sensible Control

- Factory setting
- Uses outdoor air and return air sensors that are furnished with the unit
- The Prodigy® 2.0 unit controller compares outdoor air temperature with return air
- When the outdoor air is below the configured setpoint and cooler than return air, the controller activates the economizer

NOTE - Differential Sensible Control can be configured in the field to provide Offset Differential Sensible Control or Single Sensible Control.

In Offset Differential Sensible Control mode, the economizer is enabled if the temperature differential (offset) between outdoor air and return air reaches the configured setpoint.

In Single Sensible Control mode, the economizer is enabled when outdoor air temperature falls below the configured setpoint.

Global Control

- The unit controller communicates with a DDC system with one global sensor (enthalpy or sensible)
- Determines whether outside air is suitable for free cooling on all units connected to the control system
- Sensor must be field provided

Factory or Field Installed

Single Enthalpy Temperature Control (Not for Title 24)

- Outdoor air enthalpy sensor enables Economizer if the outdoor enthalpy is less than the setpoint of the control

Differential Enthalpy Control (Not for Title 24)

- Order two Single Enthalpy Controls
- One is field installed in the return air section
- One is installed in the outdoor air section
- Allows the economizer control to select between outdoor air or return air, whichever has lower enthalpy

Field Installed

Outdoor Air CFM Control

- Maintains constant outdoor air volume levels on the supply air fan and varying unit airflows
- Velocity sensor located in the rooftop unit outdoor air section, the Prodigy® 2.0 unit controller changes the economizer position to help minimize the effect of supply fan speed changes on outdoor air volume levels
- Setpoint for outdoor air volume is established by field testing

NOTE - Not available with Demand Control Ventilation (CO₂ Sensor) or Building Pressure Control.

Building Pressure Control

- Maintains constant building pressure level
- Includes a static pressure transducer and outdoor static pressure assembly
- Using differential pressure information between the outdoor air and the building air, the Prodigy® 2.0 unit controller changes the economizer position to help maintain a constant building pressure

NOTE - Not available with Demand Control Ventilation (CO₂ Sensor) or Outdoor Air CFM Control.

EXHAUST

Factory or Field Installed

Power Exhaust Fan

- Installs internal to unit for downflow applications only with economizer option
- Provides exhaust air pressure relief
- Interlocked to run when supply air blower is operating,
- Fan runs when outdoor air dampers are 50% open (adjustable)
- Motor is overload protected
- Fan is 20 in. diameter
- Five blades
- One 1/3 hp motor

NOTE - Requires Economizer and Downflow Barometric Relief Dampers

Field Installed

Horizontal Low Profile Barometric Relief Dampers

- For use when unit is configured for horizontal applications requiring an economizer
- Allows relief of excess air
- Aluminum blade dampers prevent blow back and outdoor air infiltration during off cycle
- Field installed in return air duct
- Bird screen and hood furnished

NOTE - Requires Horizontal Discharge Kit

OPTIONS / ACCESSORIES

OUTDOOR AIR

Factory or Field Installed

Outdoor Air Damper

- Downflow or Horizontal
- Linked mechanical dampers
- 0 to 25% (fixed) outdoor air adjustable
- Installs in unit
- Includes outdoor air hood
- Automatic model features fully modulating spring return damper motor with plug-in connection
- Manual model features parallel blade, gear-driven dampers with adjustable fixed position

ROOF CURBS

Field Installed

- Nailer strip furnished (downflow only)
- Mates to unit
- US National Roofing Contractors Approved
- Shipped knocked down

Hybrid Roof Curbs, Downflow

- Interlocking tabs fasten corners together
- No tools required
- Can also be fastened together with furnished hardware
- Available in 8, 14, 18, and 24 inch heights

Adjustable Pitch Curb

- Fully adjustable pitch curbs (3/4 in. per foot in any direction) provide a level platform for rooftop units allowing flexible installations on roofs with uneven or sloped angles
- Uses interlocking tabs to fasten corners together. No tools required
- Hardware is furnished to connect upper curb with lower curb
- Available in 14 inch height

Adaptor Curbs (not shown)

- Curbs are regionally sourced
- Dimensions vary based upon the source

NOTE - Contact your local sales representative for a detailed cut sheet with applicable dimensions.

CEILING DIFFUSERS

Field Installed

Ceiling Diffusers

(Flush or Step-Down)

- White powder coat finish on diffuser face and grilles
- Insulated UL listed duct liner
- Diffuser box has collars for duct connection
- Step-down diffusers have double deflection blades
- Flush diffusers have fixed blades
- Provisions for suspending
- Internally sealed to prevent recirculation
- Removable return air grille
- Adapts to T-bar ceiling grids or plaster ceilings

Transitions (Supply and Return)

- Used with diffusers
- Installs in roof curb
- Galvanized steel construction
- Flanges furnished for duct connection to diffusers
- Fully insulated

HUMIDITROL® DEHUMIDIFICATION SYSTEM OPTION

OVERVIEW

NOTE - Not available with Environ™ Coil System.
Conventional Fin/Tube condenser coil must be ordered as a factory option.

- Factory installed option designed to control humidity
- Provides dehumidification on demand using ASHRAE 90.1 recommended method for comfort conditioning humidity control
- Unit comes equipped with one row reheat coil, solenoid valve and humidity controller
- A thermostat with a dehumidification output, a dehumidistat, or a DDC controller with an isolated output is required to control humidity and must be located in the occupied space

NOTE - Controls are not furnished and must be ordered separately.

BENEFITS

- Improves indoor air quality
- Helps prevent damage due to high humidity levels
- Improves comfort levels by reducing space humidity levels

OPERATION

No Dehumidification Demand

- The unit will operate conventionally whenever there is a demand for cooling or heating and no dehumidification demand
- Free cooling is only permitted when there is no demand for dehumidification

Dehumidification Demand Only

- Dehumidification is initiated by an output from a thermostat with a dehumidification output, a dehumidistat, or a DDC controller with an isolated output to control humidity
- Reheat operation will initiate on a dehumidification demand and does not require a cooling demand
- The unit will operate in the dehumidification mode until the relative humidity of the conditioned space is below the setpoint
- This reduces sensible cooling capacity and extends compressor run time to control humidity when the cooling load is low
- A solenoid valve diverts hot gas from the compressor to the reheat coil
- The cooled and dehumidified air from the evaporator is reheated as it passes through the reheat coil
- The de-superheated and partially condensed refrigerant continues to the outdoor condenser coil where condensing is completed
- Unit will continue to operate in this mode until the dehumidification demand is satisfied

NOTE - See Sequence of Operation for additional information.

Dehumidification and Cooling Demand (Thermostat/ Room Sensor Application)

- If both a dehumidification and a full cooling load demand occur, the system will operate in cooling until the cooling demand is satisfied
- Then the system will energize the dehumidification mode

Options / Accessories

Humidity Sensor Kit

- Remote mounted dehumidistat for factory installed Humiditrol® option
- Adjustable 20-80%

NOTE - A thermostat with a dehumidification output or a DDC controller with an isolated output can be used instead.

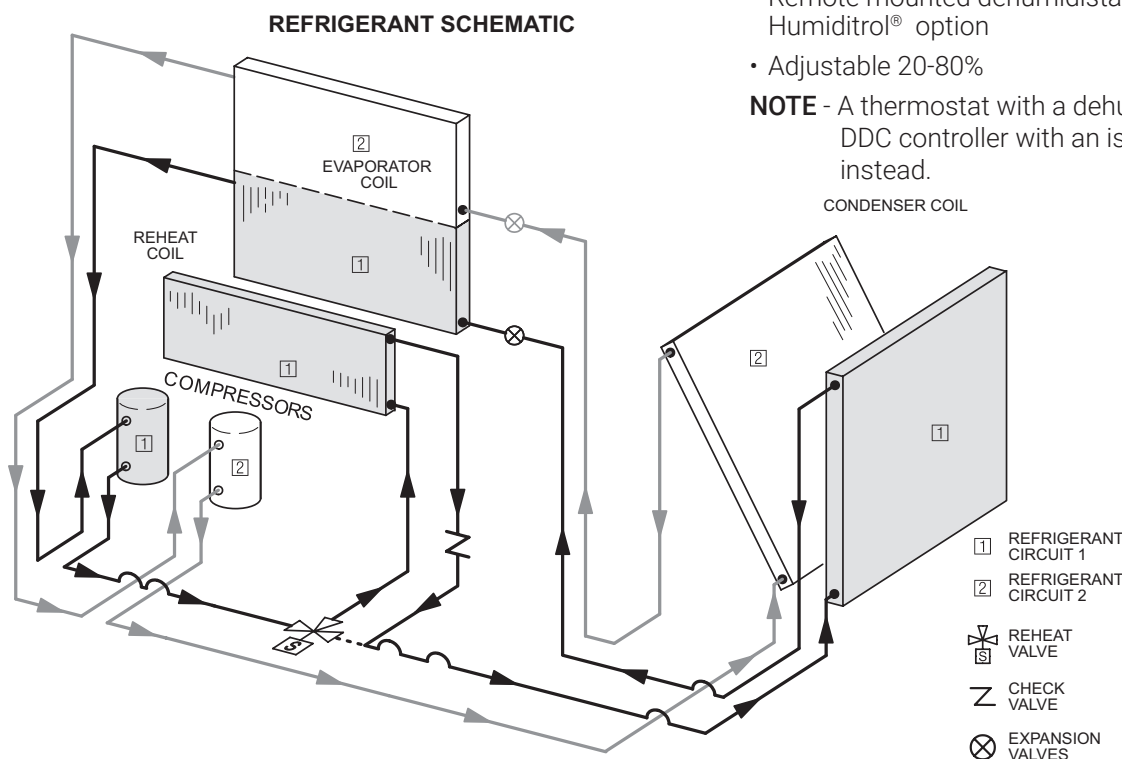

OPTIONAL CONVENTIONAL TEMPERATURE CONTROL SYSTEMS

ComfortSense® 8500 Commercial 7 Day Programmable Thermostat

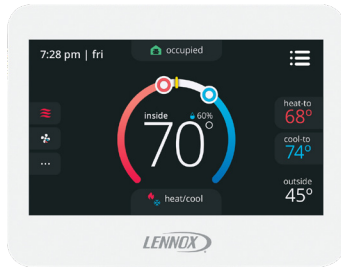

- Fully Communicating Thermostat
- Up to 4 Heat and 4 Cool
- Automatic Changeover between Heating and Cooling Modes
- Designed to maximize Prodigy® Control System Operation
- BACNet Compatible
- Remote Indoor Temperature Sensing (up to nine averaging sensors)
- Intuitive Touchscreen Interface
- Backlit Display
- Relative Humidity Sensor
- Remote Occupancy Sensing
- Outside Air Temperature Display
- Four-Wire Installation
- Scheduled Occupancy Control
- Performance Reports (standalone mode)
- Dehumidification/Humiditrol® Control
- Wallplate Furnished
- ASHRAE and IECC Compliant

ComfortSense® 7500 Commercial 7-Day Programmable Thermostat



- Four-Stage Heating / Two-Stage Cooling
- Universal Multi-Stage
- Intuitive Touchscreen Interface
- Automatic Changeover between Heating and Cooling
- Full Seven-Day Programming
- Four Time Periods Per Day
- Temperature and Humidity Control
- One-Touch Away Mode
- Holiday Scheduling
- Smooth Setback Recovery (SSR)
- Performance Reports
- Notifications/Reminders
- Dehumidification/Humiditrol® Control for Split Systems and Rooftop Units
- Economizer Relay Control
- Backlit Display
- Wallplate Furnished
- FDD, ASHRAE and IECC Compliant

OPTIONAL CONVENTIONAL TEMPERATURE CONTROL SYSTEMS

ComfortSense® 3000 Commercial 5-2 Day Programmable Thermostat

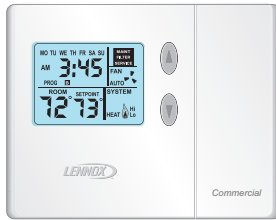

- Two-Stage Heating / Two-Stage Cooling
- Conventional Systems
- Intuitive Interface
- 5-2 Day Programming
- Program Hold
- Remote Indoor Temperature Sensing
- Smooth Setback Recovery (SSR)
- Economizer Relay Control
- Maintenance/Filter/Service Reminders
- Backlit Display
- Wallplate Furnished
- Simple Up and Down Temperature Control

ComfortSense® Non-Programmable Thermostat

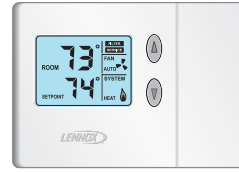

- One-Stage Heating / Cooling
- Conventional Systems
- Intuitive Interface
- Manual Changeover
- Backlit Display
- Simple Up and Down Temperature Control

OPTIONAL CONVENTIONAL TEMPERATURE CONTROL SYSTEMS

Description	Model No.	Catalog No.
ComfortSense® 8500 Commercial 7 Day Programmable Thermostat		
	No CO2 Sensing	C0STAT03FF2L
	With CO2 Sensing	C0STAT22FF2L
Sensors/Accessories	¹ Remote non-adjustable wall-mount 10k	C0SNZN73AE1-
	¹ Remote non-adjustable wall-mount 11k	C0SNZN08AE1
	Locking cover (clear)	C0MISC15AE1

¹ Up to nine of the same type remote temperature sensors can be connected in parallel.

Sysbus Network Cable (Yellow) for ComfortSense 8500

Twisted pair 100% shielded communication cable, Red and Black	500 ft. box	C0MISC00AE1-	27M19
22 AWG, yellow jacket, rated at 75°C, 300V, Plenum rated	1000 ft. box	C0MISC04AE1-	94L63
Insulation - Low smoke PVC, NEC, CMP	2500 ft. roll	C0MISC01AE1-	68M25

ComfortSense® 7500 Commercial 7-Day Programmable Thermostat

		C0STAT06FF2L	17G74
Sensors/Accessories	² Remote non-adjustable wall-mount 20k	C0SNZN01AE2-	47W36
	² Remote non-adjustable wall-mount 10k	C0SNZN73AE1-	47W37
	Remote non-adjustable discharge air (duct mount)	C0SNDC00AE1-	19L22
	Outdoor temperature sensor	C0SNSR03AE1-	X2658
	Universal thermostat locking guard (clear)	C0MISC15AE1-	39P21

² Remote wall-mount sensors can be applied in any of the following combinations:

- One Sensor - (1) 47W36
- Two Sensors - (2) 47W37
- Three Sensors - (2) 47W36 and (1) 47W37
- Four Sensors - (4) 47W36
- Five Sensors - (3) 47W36 and (2) 47W37

ComfortSense® 3000 Commercial 5-2 Day Programmable Thermostat

		C0STAT05FF1L	11Y05
Sensors/Accessories	Remote non-adjustable wall mount 10k averaging	C0SNZN73AE1-	47W37
	Thermostat wall mounting plate	C0MISC17AE1-	X2659

ComfortSense® Non-Programmable Thermostat

		C0STAT12AE1L	51M32
--	--	--------------	--------------

Objective: Outline the unit functions as a result of room thermostat or zone sensor demands.

Given: When economizer is present, it will function as an integral part of the unit cooling system. When not present, unit will function as if economizer is present but outdoor ambient is high and sensed as not suitable.

UNIT OPERATION WITH 2-STAGE THERMOSTAT (2 COOL AND 2 HEAT STAGES, Y1, Y2, W1, W2)

SUPPLY AIR BLOWER SPEED

Unit has following supply air blower speed setting:

- Ventilation speed
- Cooling Speed - Low
- Cooling Speed - High
- Heating speed
- Smoke speed (Used only in smoke removal option - not discussed)

¹ Unit Features An Economizer And Outdoor Air Is Suitable

Cooling - Thermostat Mode (Y1, Y2)

Y1 Demand:

All compressors are off, supply air blower is on low cooling speed to minimize blower power consumption, economizer modulates (minimum to maximum open position) to maintain 55°F supply air temperature (default unit controller setting).

Y2 Demand:

All compressors are off, supply air blower is on high cooling speed providing higher cooling capacity, and economizer modulates to maintain 55°F supply air temperature.

If economizer stays at maximum open for 3 minutes, compressor 1 is energized while supply air blower stays on high cooling speed providing maximum cooling capacity.

¹ *Outdoor air suitability is determined by the energy state of outdoor ambient (enthalpy or sensible) and its ability to achieve the desired free cooling effects. Outdoor air suitability can also be determined by a third party controller and provided to the rooftop unit via a network connection.*

Unit Does Not Feature An Economizer or Outdoor Air Is Not Suitable

Y1 Demand:

Compressor 1 operates and supply air blower operates at low cooling speed.

Y2 Demand:

All compressors operate and supply air blower operates at high cooling speed.

Dehumidification Mode

If a unit with Humiditrol® Dehumidification Option receives a call for dehumidification, economizer free cooling is locked out.

Call For Dehumidification, No Y1, Y2 demand:

1st stage compressor operates, supply air blower operates at high cooling speed, and the reheat valve is energized.

Y1 Demand With A Call For Dehumidification:

All compressors operate, supply air blower operates at high cooling speed and the reheat valve is energized.

Y2 Demand With A Call For Dehumidification:

All compressors operate, supply air blower operates at high cooling speed, and the reheat valve is de-energized.

UNIT OPERATION WITH 3-STAGE THERMOSTAT OR ZONE SENSOR (3 COOL AND 2 HEAT STAGES, Y1, Y2, Y3 AND W1, W2)

SUPPLY AIR BLOWER SPEED

Unit has following supply air blower speed setting:

- Ventilation speed
- Cooling Speed - Low
- Cooling Speed - High
- Heating speed
- Smoke speed (Used only in smoke removal option - not discussed)

¹ Unit Features An Economizer And Outdoor Air Is Suitable

Cooling - Thermostat or Zone Sensor Mode (Y1, Y2, Y3)

Y1 Demand:

All compressors are off, supply air blower is on low cooling speed to minimize blower power consumption, economizer modulates (minimum to maximum open position) to maintain 55°F supply air temperature (default unit controller setting).

Y2 Demand:

All compressors are off, supply air blower is on high cooling speed providing higher cooling capacity, and economizer modulates to maintain 55°F supply air temperature.

If economizer stays at maximum open for 3 minutes, compressor 1 is energized while supply air blower stays on high cooling speed providing maximum cooling capacity. After compressors are energized the economizer stays at maximum open.

Y3 Demand:

Compressors 1 and 2 are energized while supply air blower stays on high cooling speed.

¹ *Outdoor air suitability is determined by the energy state of outdoor ambient (enthalpy or sensible) and its ability to achieve the desired free cooling effects. Outdoor air suitability can also be determined by a third party controller and provided to the rooftop unit via a network connection.*

Unit Does Not Feature An Economizer or Outdoor Air Is Not Suitable

Y1 Demand:

Compressor 1 operates and supply air blower operates at low cooling speed.

Y2 or Y3 Demand:

All compressors operate and supply air blower operates at high cooling speed.

Dehumidification Mode

If a unit with Humiditrol® Dehumidification Option receives a call for dehumidification, economizer free cooling is locked out.

Call For Dehumidification, No Y1, Y2 demand:

1st stage compressor operates, supply air blower operates at high cooling speed, and the reheat valve is energized.

Y1 Demand With A Call For Dehumidification:

All compressors operate, supply air blower operates at high cooling speed and the reheat valve is energized.

Y2 Or Y3 Demand With A Call For Dehumidification:

All compressors operate, supply air blower operates at high cooling speed, and the reheat valve is de-energized.

HEATING MODE (ELECTRIC HEAT)

NOTE - HEATING MODE IS THE SAME FOR ALL CONTROL OPTIONS

W1 Demand:

1st stage electric heat is energized and the supply air blower operates at heating speed.

W2 Demand:

2nd stage electric heat is energized and the supply air blower operates at heating speed (45 or 60 kW electric heat option only).

MODULATING OUTDOOR AIR DAMPER

The minimum damper position for “occupied low blower” and “occupied high blower” is adjusted during unit setup to provide minimum fresh air requirements per ASHRAE 62.1 at the corresponding supply air blower speeds.

When supply air blower is off or the unit is in unoccupied mode, the outdoor air damper is closed.

When unit is in occupied mode and supply air blower is operating at a speed below the “midpoint” blower speed, the outdoor air damper is at minimum “low blower” position.

When unit is in occupied mode and supply air blower is operating at a speed equal to or above the “midpoint” blower speed, the outdoor air damper is at minimum “high blower” position.

NOTE - The “midpoint” blower speed is an average of the minimum and maximum blower speed (minimum speed + maximum speed divided by 2).

POWER EXHAUST

NOTE - POWER EXHAUST OPERATION IS THE SAME FOR ALL CONTROL OPTIONS

Power exhaust blower operates when economizer outdoor air dampers are 50% open (adjustable) and when supply air blower speed is above 70% (adjustable) of full speed.

OPTIONS / ACCESSORIES

Item Description	Model Number	Catalog Number	Unit Model No			
			092	102	120	150
COOLING SYSTEM						
Condensate Drain Trap	PVC - C1TRAP20AD2	76W26	OX	OX	OX	OX
	Copper - C1TRAP10AD2	76W27	OX	OX	OX	OX
Conventional Fin/Tube Condenser Coil (replaces Environ Coil System)		Factory	O	O	O	
Corrosion Protection		Factory	O	O	O	O
Drain Pan Overflow Switch	E1SNSR71AD1	68W88	OX	OX	OX	OX
Refrigerant Type		R-410A	O	O	O	O
Service Valves (not for Environ™ Coil System or Humiditrol® equipped units)		Factory	O	O	O	O
BLOWER - SUPPLY AIR						
Blower Option	CAV (Constant Air Volume)	Factory	O	O	O	O
	MSAV (Multi-Stage Air Volume) supply air blower option (With VFD Bypass Control)	Factory	O	O	O	O
	MSAV (Multi-Stage Air Volume) supply air blower option (Without VFD Bypass Control)	Factory	O	O	O	O
Motors - Constant Air Volume (CAV)	Belt Drive (standard efficiency) - 2 hp	Factory	O	O	O	O
	Belt Drive (standard or high efficiency) - 3 hp	Factory	O	O	O	O
	Belt Drive (standard efficiency) - 5 hp	Factory	O	O	O	O
Motors - MSAV® (Multi-Stage Air Volume)	Belt Drive (standard efficiency) - 2 hp	Factory	O	O	O	O
	Belt Drive (standard efficiency) - 3 hp	Factory	O	O	O	O
	Belt Drive (standard efficiency) - 5 hp	Factory	O	O	O	O
Drive Kits See Blower Data Tables for selection	Kit #1 590-890 rpm	Factory	O	O	O	O
	Kit #2 800-1105 rpm	Factory	O	O	O	O
	Kit #3 795-1195 rpm	Factory	O	O	O	O
	Kit #4 730-970 rpm	Factory	O	O	O	O
	Kit #5 940-1200 rpm	Factory	O	O	O	O
	Kit #6 1015-1300 rpm	Factory	O	O	O	O
	Kit #7 730-970 rpm	Factory	O	O	O	O
	Kit #8 940-1200 rpm	Factory	O	O	O	O
	Kit #9 1015-1300 rpm	Factory	O	O	O	O
	Kit #10 900-1135 rpm	Factory	O	O	O	O
	Kit #11 1040-1315 rpm	Factory	O	O	O	O
	Kit #12 1125-1425 rpm	Factory	O	O	O	O
	Blower Belt Auto-Tensioner	Factory	O	O	O	O
CABINET						
Combination Coil/ Hail Guards	Furnished Environ™ Coil System - C1GARD52B-1	13T05	X	X	X	
	Optional Conventional Fin/Tube Condenser Coil - E1GARD51B-1	13T04	X	X	X	
	Furnished Conventional Fin/Tube Condenser Coil System - C1GARD52B-1	13T05				X
Horizontal Discharge Kit	K1HECK00B-1	51W25	X	X	X	X
Return Air Adaptor Plate (for LC/LG/LH and TC/TG/TH unit replacement)	C1CONV10B-1	54W96	OX	OX	OX	OX

NOTE - Catalog and model numbers shown are for ordering field installed accessories.

OX - Configure To Order (Factory Installed) or Field Installed

O = Configure To Order (Factory Installed)

X = Field Installed

OPTIONS / ACCESSORIES

Item Description	Model Number	Catalog Number	Unit Model No			
			092	102	120	150
CONTROLS						
Blower Proving Switch	C1SNSR35FF1	53W65	OX	OX	OX	OX
Commercial Controls	Prodigy® Control System - BACnet® Module - C0CTRL60AE1L	59W51	OX	OX	OX	OX
	Prodigy® Control System - LonTalk® Module - C0CTRL65FF1	54W27	OX	OX	OX	OX
	Novar® LSE L Connection® Building Automation System	Factory ---	O	O	O	O
Dirty Filter Switch	E1SNSR55B-1	53W67	OX	OX	OX	OX
General Purpose Control Kit	E1GPBK30C1	13J78	X	X	X	X
Fresh Air Tempering	C1SNSR75AD1	58W63	OX	OX	OX	OX
Smoke Detector - Supply or Return (Power board and one sensor)	C1SNSR44B-2	11K76	OX	OX	OX	OX
Smoke Detector - Supply and Return (Power board and two sensors)	C1SNSR43B-2	11K80	OX	OX	OX	OX
INDOOR AIR QUALITY						
Air Filters						
Healthy Climate® High Efficiency Air Filters 20 x 25 x 2 in. (Order 4 per unit)	MERV 8 - C1FLTR15B-1	50W61	OX	OX	OX	OX
	MERV 13 - C1FLTR40B-1	52W41	OX	OX	OX	OX
Replacement Media Filter With Metal Mesh Frame (includes non-pleated filter media)	C1FLTR30B-1-	Y3063	X	X	X	X
Indoor Air Quality (CO2) Sensors						
Sensor - Wall-mount, off-white plastic cover with LCD display	C0SNSR50AE1L	77N39	X	X	X	X
Sensor - Wall-mount, off-white plastic cover, no display	C0SNSR52AE1L	87N53	X	X	X	X
Sensor - Black plastic case with LCD display, rated for plenum mounting	C0SNSR51AE1L	87N52	X	X	X	X
Sensor - Wall-mount, black plastic case, no display, rated for plenum mounting	C0MISC19AE1	87N54	X	X	X	X
CO2 Sensor Duct Mounting Kit - for downflow applications	C0MISC19AE1-	85L43	X	X	X	X
Aspiration Box - for duct mounting non-plenum rated CO2 sensors (87N53 or 77N39)	C0MISC16AE1-	90N43	X	X	X	X
UVC Germicidal Lamps						
¹ Healthy Climate® UVC Light Kit (208/230v-1ph)	C1UVCL10B-1	54W62	X	X	X	X
HUMIDITROL® DEHUMIDIFICATION CONDENSER REHEAT OPTION						
Humiditrol Dehumidification Option		Factory	O	O	O	O
Humidity Sensor Kit, Remote mounted (required)	C0SNSR31AE-1	17M50	X	X	X	X
ELECTRICAL						
Voltage 60 hz	208/230V - 3 phase	Factory	O	O	O	O
	460V - 3 phase	Factory	O	O	O	O
	575V - 3 phase	Factory	O	O	O	O
HACR Circuit Breakers		Factory	O	O	O	O
Disconnect Switch - See Electrical/Electric Heat tables for selection	80 amp - C1DISC080B-1	54W56	OX	OX	OX	OX
	150 amp - C1DISC150B-1	54W57	OX	OX	OX	OX
² Short-Circuit Current Rating (SCCR) of 100kA (includes Phase/Voltage Detection)		Factory	O	O	O	O
GFI Service Outlets	15 amp non-powered, field-wired (208/230V, 460V only) LTAGFIK10/15	74M70	OX	OX	OX	OX
	20 amp non-powered, field-wired (575V only) C1GFIC120FF1	67E01	OX	OX	OX	OX
Weatherproof Cover for GFI	C1GFIC199FF1	10C89	X	X	X	X
Phase/Voltage Detection (Optional for CAV options only, furnished with MSAV® option)		Factory	O	O	O	O

¹ Lamps operate on 110-230V single-phase power supply. Step-down transformer may be ordered separately for 460V and 575V units. Alternately, 110V power supply may be used to directly power the UVC ballast(s).

² Disconnect Switch not available with higher SCCR option. Short-Circuit Current Rating option not available on field installed electric heat.

NOTE - Catalog and model numbers shown are for ordering field installed accessories.

OX - Configure To Order (Factory Installed) or Field Installed

O = Configure To Order (Factory Installed)

X = Field Installed

OPTIONS / ACCESSORIES

Item Description	Model Number	Catalog Number	Unit Model No			
			092	102	120	150
ELECTRIC HEAT						
7.5 kW	208/230V-3ph - C1EH0075B-1Y	56W38	OX	OX		
	460V-3ph - C1EH0075B-1G	56W39	OX	OX		
	575V-3ph - C1EH0075B-1J	56W40	OX	OX		
15 kW	208/230V-3ph - C1EH0015B-1Y	56W41	OX	OX	OX	OX
	460V-3ph - C1EH0150B-1G	56W42	OX	OX	OX	OX
	575V-3ph - C1EH0150B-1J	56W43	OX	OX	OX	OX
22.5 kW	208/230V-3ph - C1EH0225B-1Y	56W44	OX	OX	OX	OX
	460V-3ph - C1EH0225B-1G	56W45	OX	OX	OX	OX
	575V-3ph - C1EH0225B-1J	56W46	OX	OX	OX	OX
30 kW	208/230V-3ph - C1EH0300B-1Y	56W47	OX	OX	OX	OX
	460V-3ph - C1EH0300B-1G	56W48	OX	OX	OX	OX
	575V-3ph - C1EH0300B-1J	56W49	OX	OX	OX	OX
45 kW	208/230V-3ph - C1EH0450B-1Y	56W50	OX	OX	OX	OX
	460V-3ph - C1EH0450B-1G	56W51	OX	OX	OX	OX
	575V-3ph - C1EH0450B-1J	56W52	OX	OX	OX	OX
60 kW	208/230V-3ph - C1EH0600B-1Y	55W02			OX	OX
	460V-3ph - C1EH0600B-1G	55W03			OX	OX
	575V-3ph - C1EH0600B-1J	55W04			OX	OX
¹ SCR (Silicon Controlled Rectifier) Electric Heat Control		Factory	O	O	O	O
Thermostat (required)		Y9682	X	X	X	X
Duct Sensor (required)		Y9683	X	X	X	X

ECONOMIZER

High Performance Economizer (Approved for California Title 24 Building Standards / AMCA Class 1A Certified)

High Performance Economizer	E1ECON17B-2	17U08	OX	OX	OX	OX
Downflow or Horizontal - Includes Outdoor Air Hood and Downflow						
Barometric Relief Dampers with Exhaust Hood						
Order Horizontal Barometric Relief Dampers separately						

Horizontal Barometric Relief Dampers

Horizontal Low Profile Barometric Relief Dampers (Exhaust hood furnished)	LAGEDH03/15	53K04	X	X	X	X
---	-------------	--------------	---	---	---	---

Economizer Controls

Differential Enthalpy (Not for Title 24)	Order 2 - C1SNSR64FF1	53W64	OX	OX	OX	OX
Sensible Control	Sensor is Furnished	Factory	O	O	O	O
Single Enthalpy (Not for Title 24)	C1SNSR64FF1	53W64	OX	OX	OX	OX
Building Pressure Control	E1GPBK20C1	13J77	X	X	X	X
Outdoor Air CFM Control	E1GPBK10C1	13J76	X	X	X	X
Global Control	Sensor Field Provided	Factory	O	O	O	O

OUTDOOR AIR

Outdoor Air Dampers With Outdoor Air Hood

Motorized	C1DAMP20B-1	14G28	OX	OX	OX	OX
Manual	C1DAMP10B-2	14G29	OX	OX	OX	OX

POWER EXHAUST

Standard Static	208/230V-3ph - K1PWRE10B-1Y	53W44	OX	OX	OX	OX
	460V-3ph - K1PWRE10B-1G	53W45	OX	OX	OX	OX
	575V-3ph - K1PWRE10B-1J	53W46	OX	OX	OX	OX

¹ NOTE - The SCR option is not available with 45 kW and 60 kW electric heat (208/230V) models.

NOTE - Catalog and model numbers shown are for ordering field installed accessories.

OX = Configure To Order (Factory Installed) or Field Installed

O = Configure To Order (Factory Installed)

X = Field Installed

OPTIONS / ACCESSORIES

Item Description	Model Number	Catalog Number	Unit Model No			
			092	102	120	150
ROOF CURBS						
Hybrid Roof Curbs, Downflow						
8 in. height	C1CURB70B-1	11F54	X	X	X	X
14 in. height	C1CURB71B-1	11F55	X	X	X	X
18 in. height	C1CURB72B-1	11F56	X	X	X	X
24 in. height	C1CURB73B-1	11F57	X	X	X	X
Adjustable Pitch Curb						
14 in. height	C1CURB55B-1	54W50	X	X	X	X
CEILING DIFFUSERS						
Step-Down - Order one	RTD11-95S	13K61	X			
	RTD11-135S	13K62		X	X	
	RTD11-185S	13K63				X
Flush - Order one	FD11-95S	13K56	X			
	FD11-135S	13K57		X	X	
	FD11-185S	13K58				X
Transitions (Supply and Return) - Order one	C1DIFF30B-1	12X65	X			
	C1DIFF31B-1	12X66		X	X	
	C1DIFF32B-1	12X67				X

NOTE - Catalog and model numbers shown are for ordering field installed accessories.

OX - Configure To Order (Factory Installed) or Field Installed

O = Configure To Order (Factory Installed)

X = Field Installed

SPECIFICATIONS

General Data		Nominal Tonnage	7.5 Ton	7.5 Ton	8.5 Ton	8.5 Ton
Model Number			LCH092H4B	LCH092H4M	LCH102H4B	LCH102H4M
Efficiency Type			High	High	High	High
Blower Type			Constant Air Volume (CAV)	MSAV® (Multi-Stage Air Volume)	Constant Air Volume (CAV)	MSAV® (Multi-Stage Air Volume)
Cooling Performance	Gross Cooling Capacity - Btuh		93,000	93,000	103,800	103,800
	¹ Net Cooling Capacity - Btuh		90,000	90,000	100,000	100,000
	AHRI Rated Air Flow - cfm		3000	2800	3400	3400
	Total Unit Power - kW		7.5	7.5	8.1	8.1
	¹ EER (Btuh/Watt)		12.7	12.7	12.4	12.4
	² IEER (Btuh/Watt)		13.0	14.0	12.9	14.0
Refrigerant Charge	Refrigerant Type		R-410A	R-410A	R-410A	R-410A
	Environ™ Coil System	Circuit 1	6 lbs. 6 oz.	6 lbs. 6 oz.	6 lbs. 8 oz.	6 lbs. 8 oz.
		Circuit 2	6 lbs. 7 oz.	6 lbs. 7 oz.	6 lbs. 12 oz.	6 lbs. 12 oz.
	Environ™ Coil System with Humiditrol®	Circuit 1	6 lbs. 6 oz.	6 lbs. 6 oz.	6 lbs. 8 oz.	6 lbs. 8 oz.
		Circuit 2	6 lbs. 7 oz.	6 lbs. 7 oz.	6 lbs. 12 oz.	6 lbs. 12 oz.
	Conventional Fin/Tube Coil Option	Circuit 1	13 lbs. 8 oz.	13 lbs. 8 oz.	13 lbs. 8 oz.	13 lbs. 8 oz.
		Circuit 2	12 lbs. 8 oz.	12 lbs. 8 oz.	12 lbs. 8 oz.	12 lbs. 8 oz.
	Conventional Fin/Tube With Humiditrol®	Circuit 1	17 lbs. 0 oz.	17 lbs. 0 oz.	17 lbs. 0 oz.	17 lbs. 0 oz.
		Circuit 2	12 lbs. 8 oz.	12 lbs. 8 oz.	12 lbs. 8 oz.	12 lbs. 8 oz.
	Electric Heat Available - See page 20			7.5, 15, 22.5, 30 & 45 kW		
Compressor Type (number)			Scroll (2)	Scroll (2)	Scroll (2)	Scroll (2)
Outdoor Coils	Net face area (total) - sq. ft.		28.0 (29.33)	28.0 (29.33)	28.0 (29.33)	28.0 (29.33)
	Environ (Fin/Tube)	Number of rows	1 (3)	1 (3)	1 (3)	1 (3)
Fins per inch		20 (20)	20 (20)	20 (20)	20 (20)	
Outdoor Coil Fans	Motor - (No.) hp		(2) 1/3	(2) 1/3	(2) 1/3	(2) 1/3
	Motor rpm		1075	1075	1075	1075
	Total Motor watts		800	800	800	800
	Diameter - (No.) in.		(2) 24	(2) 24	(2) 24	(2) 24
	Number of blades		3	3	3	3
	Total Air volume - cfm		8800	8800	8800	8800
Indoor Coil	Net face area (total) - sq. ft.		12.78	12.78	12.78	12.78
	Tube diameter - in.		3/8	3/8	3/8	3/8
	Number of rows		4	4	4	4
	Fins per inch		14	14	14	14
Drain connection - Number and size		(1) 1 in. NPT coupling				
Expansion device type		Balance port TXV, removable head				
³ Indoor Blower and Drive Selection	Nominal motor output		2 hp, 3 hp, 5 hp			
	Maximum usable motor output (US Only)		2.3 hp, 3.45 hp, 5.75 hp			
	Motor - Drive kit number		2 hp Kit 1 590-890 rpm (std. and high efficiency) Kit 2 800-1105 rpm (std. and high efficiency) Kit 3 795-1195 rpm (std. and high efficiency)			
			3 hp Kit 4 730-970 rpm (std. efficiency) Kit 5 940-1200 rpm (std. efficiency) Kit 6 1015-1300 rpm (std. efficiency) Kit 7 730-970 rpm (high efficiency) Kit 8 940-1200 rpm (high efficiency) Kit 9 1015-1300 rpm (high efficiency)			
			5 hp Kit 10 900-1135 rpm (std. efficiency) Kit 11 1040-1315 rpm (std. efficiency) Kit 12 1125-1425 rpm (std. efficiency)			
Blower wheel nominal diameter x width - in.			(1) 15 X 15	(1) 15 X 15	(1) 15 X 15	(1) 15 X 15
Filters	Type of filter		Disposable			
	Number and size - in.		(4) 20 x 25 x 2			
Electrical characteristics			208/230V, 460V or 575V - 60 hertz - 3 phase			

NOTE - Net capacity includes evaporator blower motor heat deduction. Gross capacity does not include evaporator blower motor heat deduction.

¹ AHRI Certified to AHRI Standard 340/360; 95°F outdoor air temperature and 80°F db/67°F wb entering evaporator air; minimum external duct static pressure.

² Integrated Energy Efficiency Ratio certified and tested according to AHRI Standard 340/360.

³ Using total air volume and system static pressure requirements determine from blower performance tables rpm and motor output required. Maximum usable output of motors furnished are shown. In Canada, nominal motor output is also maximum usable motor output. If motors of comparable output are used, be sure to keep within the service factor limitations outlined on the motor nameplate.

NOTE - Units equipped with MSAV® (Multi-Stage Air Volume) option are limited to a motor service factor of 1.0.

SPECIFICATIONS

General Data		Nominal Tonnage	10 Ton	10 Ton	12.5 Ton	12.5 Ton
		Model Number	LCH120H4B	LCH120H4M	LCH150H4B	LCH150H4M
		Efficiency Type	High	High	High	High
		Blower Type	Constant Air Volume (CAV)	MSAV® (Multi-Stage Air Volume)	Constant Air Volume (CAV)	MSAV® (Multi-Stage Air Volume)
Cooling Performance	Gross Cooling Capacity - Btuh		122,000	122,000	143,000	143,000
	¹ Net Cooling Capacity - Btuh		118,000	118,000	138,000	138,000
	AHRI Rated Air Flow - cfm		3600	3300	3950	3950
	Total Unit Power - kW		9.9	9.8	12.6	12.6
	¹ EER (Btuh/Watt)		12.2	12.2	11.0	11.0
	² IEER (Btuh/Watt)		13.2	14.0	12.4	13.5
Refrigerant Charge	Refrigerant Type		R-410A	R-410A	R-410A	R-410A
	Environ™ Coil System	Circuit 1	7 lbs. 0 oz.	7 lbs. 0 oz.	---	---
		Circuit 2	6 lbs. 12 oz.	6 lbs. 12 oz.	---	---
	Environ™ Coil System with Humiditrol®	Circuit 1	7 lbs. 4 oz.	7 lbs. 4 oz.	---	---
		Circuit 2	7 lbs. 8 oz.	7 lbs. 8 oz.	---	---
	Conventional Fin/Tube	Circuit 1	14 lbs. 8 oz.	14 lbs. 8 oz.	14 lbs. 0 oz.	14 lbs. 0 oz.
	Coil Option	Circuit 2	13 lbs. 8 oz.	13 lbs. 8 oz.	13 lbs. 8 oz.	13 lbs. 8 oz.
	Conventional Fin/Tube with Humiditrol®	Circuit 1	17 lbs. 8 oz.	17 lbs. 8 oz.	14 lbs. 6 oz.	14 lbs. 6 oz.
	Circuit 2	13 lbs. 8 oz.	13 lbs. 8 oz.	13 lbs. 8 oz.	13 lbs. 8 oz.	
Electric Heat Available - See page 20			15, 22.5, 30, 45 & 60 kW			
Compressor Type (number)			Scroll (2)	Scroll (2)	Scroll (2)	Scroll (2)
Outdoor Coils	Net face area (total) - sq. ft.		28.0 (29.33)	28.0 (29.33)	--- (28.0)	--- (28.0)
	Environ (Fin/Tube)	Number of rows	1 (3)	1 (3)	3	3
Fins per inch		20 (20)	20 (20)	20	20	
Outdoor Coil Fans	Motor - (No.) hp		(2) 1/3	(2) 1/3	(2) 1/2	(2) 1/2
	Motor rpm		1075	1075	1075	1075
Total Motor watts			800	800	1050	1050
Diameter - (No.) in.			(2) 24	(2) 24	(2) 24	(2) 24
Number of blades			3	3	3	3
Total Air volume - cfm			8800	8800	9700	9700
Indoor Coil	Net face area (total) - sq. ft.		13.54	13.54	13.54	13.54
	Tube diameter - in.		3/8	3/8	3/8	3/8
	Number of rows		4	4	4	4
	Fins per inch		14	14	14	14
	Drain connection - Number and size		(1) 1 in. NPT coupling			
Expansion device type		Balance port TXV, removable head				
³ Indoor Blower and Drive Selection	Nominal motor output		2 hp, 3 hp, 5 hp			
	Maximum usable motor output (US Only)		2.3 hp, 3.45 hp, 5.75 hp			
	Motor - Drive kit number		2 hp Kit 1 590-890 rpm (std. and high efficiency) Kit 2 800-1105 rpm (std. and high efficiency) Kit 3 795-1195 rpm (std. and high efficiency) 3 hp Kit 4 730-970 rpm (std. efficiency) Kit 5 940-1200 rpm (std. efficiency) Kit 6 1015-1300 rpm (std. efficiency) Kit 7 730-970 rpm (high efficiency) Kit 8 940-1200 rpm (high efficiency) Kit 9 1015-1300 rpm (high efficiency) 5 hp Kit 10 900-1135 rpm (std. efficiency) Kit 11 1040-1315 rpm (std. efficiency) Kit 12 1125-1425 rpm (std. efficiency)			
Blower wheel nominal diameter x width - in.			(1) 15 X 15	(1) 15 X 15	(1) 15 X 15	(1) 15 X 15
Filters	Type of filter		Disposable			
	Number and size - in.		(4) 20 x 25 x 2			
Electrical characteristics			208/230V, 460V or 575V - 60 hertz - 3 phase			

NOTE - Net capacity includes evaporator blower motor heat deduction. Gross capacity does not include evaporator blower motor heat deduction.

¹ AHRI Certified to AHRI Standard 340/360; 95°F outdoor air temperature and 80°F db/67°F wb entering evaporator air; minimum external duct static pressure.

² Integrated Energy Efficiency Ratio certified and tested according to AHRI Standard 340/360.

³ Using total air volume and system static pressure requirements determine from blower performance tables rpm and motor output required. Maximum usable output of motors furnished are shown. In Canada, nominal motor output is also maximum usable motor output. If motors of comparable output are used, be sure to keep within the service factor limitations outlined on the motor nameplate.

NOTE - Units equipped with MSAV® (Multi-Stage Air Volume) option are limited to a motor service factor of 1.0.

092 AND 102 BELT DRIVE BLOWER – BASE UNIT

BLOWER TABLE INCLUDES RESISTANCE FOR BASE UNIT ONLY (NO HEAT SECTION) WITH DRY INDOOR COIL AND AIR FILTERS IN PLACE.

FOR ALL UNITS ADD:

- 1 – Wet indoor coil air resistance of selected unit.
- 2 – Any factory installed options air resistance (heat section, economizer, etc.)
- 3 – Any field installed accessories air resistance (duct resistance, diffuser, etc.)

Then determine from blower table blower motor output required.

See page 32 for blower motors and drives. See page 32 for wet coil and option/accessory air resistance data.

MINIMUM AIR VOLUME REQUIRED FOR USE WITH OPTIONAL ELECTRIC HEAT (Maximum Static Pressure - 2.0 in. w.g.)

7.5 kW, 15 kW, 22.5 kW, 30 kW and 45 kW - 2800 cfm

Total Air Volume cfm	Total Static Pressure – in. w.g.																											
	0.2		0.4		0.6		0.8		1.0		1.2		1.4		1.6		1.8		2.0		2.2		2.4		2.6			
	RPM	BHP	RPM	BHP	RPM	BHP	RPM	BHP	RPM	BHP	RPM	BHP	RPM	BHP	RPM	BHP	RPM	BHP	RPM	BHP	RPM	BHP	RPM	BHP	RPM	BHP	RPM	BHP
1750	481	0.21	549	0.4	618	0.57	688	0.7	758	0.82	824	0.93	885	1.08	941	1.23	991	1.39	1038	1.54	1082	1.68	1124	1.82	1166	1.95		
2000	493	0.29	561	0.47	629	0.64	700	0.77	768	0.9	832	1.02	892	1.17	946	1.33	995	1.49	1041	1.66	1085	1.81	1126	1.97	1167	2.12		
2250	507	0.37	574	0.56	643	0.72	712	0.86	779	0.99	842	1.13	900	1.28	953	1.44	1001	1.61	1045	1.78	1088	1.95	1128	2.12	1168	2.3		
2500	521	0.46	588	0.64	657	0.81	727	0.95	792	1.09	853	1.24	909	1.4	960	1.57	1007	1.74	1050	1.93	1091	2.11	1130	2.29	1170	2.48		
2750	537	0.56	604	0.74	674	0.91	743	1.06	806	1.21	865	1.36	920	1.53	969	1.71	1014	1.89	1055	2.08	1095	2.27	1133	2.47	1172	2.66		
3000	554	0.67	622	0.86	692	1.02	760	1.18	822	1.34	878	1.5	931	1.68	979	1.86	1021	2.06	1061	2.26	1099	2.46	1136	2.65	1174	2.85		
3250	572	0.78	641	0.98	712	1.15	778	1.32	838	1.49	892	1.66	943	1.84	989	2.03	1030	2.24	1068	2.45	1105	2.65	1141	2.85	1178	3.06		
3500	592	0.9	663	1.12	733	1.3	798	1.47	855	1.65	907	1.83	956	2.02	1000	2.22	1039	2.44	1076	2.65	1111	2.86	1146	3.07	1183	3.27		
3750	614	1.04	687	1.28	756	1.47	818	1.65	872	1.83	923	2.02	970	2.22	1011	2.43	1049	2.65	1084	2.87	1118	3.09	1152	3.29	1189	3.51		
4000	639	1.22	713	1.48	780	1.66	838	1.83	890	2.02	939	2.22	984	2.44	1023	2.66	1059	2.89	1093	3.11	1126	3.33	1160	3.54	1197	3.77		
4250	667	1.43	741	1.69	805	1.86	859	2.02	909	2.22	956	2.45	998	2.68	1036	2.92	1070	3.15	1103	3.37	1135	3.59	1169	3.81	1207	4.05		

BLOWER DATA

10 TON | 12.5 TON

120 AND 150 BELT DRIVE BLOWER – BASE UNIT

BLOWER TABLE INCLUDES RESISTANCE FOR BASE UNIT ONLY (NO HEAT SECTION) WITH DRY INDOOR COIL AND AIR FILTERS IN PLACE.

FOR ALL UNITS ADD:

- 1 – Wet indoor coil air resistance of selected unit.
- 2 – Any factory installed options air resistance (heat section, economizer, etc.)
- 3 – Any field installed accessories air resistance (duct resistance, diffuser, etc.)

Then determine from blower table blower motor output required.

See page 32 for blower motors and drives. See page 32 for wet coil and option/accessory air resistance data.

MINIMUM AIR VOLUME REQUIRED FOR USE WITH OPTIONAL ELECTRIC HEAT (Maximum Static Pressure - 2.0 in. w.g.)

15 kW, 22.5 kW, 30 kW and 45 kW - 2800 cfm

60 kW - 4000 cfm

Total Air Volume cfm	Total Static Pressure – in. w.g.																											
	0.2		0.4		0.6		0.8		1.0		1.2		1.4		1.6		1.8		2.0		2.2		2.4		2.6			
	RPM	BHP	RPM	BHP	RPM	BHP	RPM	BHP	RPM	BHP	RPM	BHP	RPM	BHP	RPM	BHP	RPM	BHP	RPM	BHP	RPM	BHP	RPM	BHP	RPM	BHP	RPM	BHP
2000	497	0.25	558	0.44	624	0.6	694	0.74	764	0.85	830	0.99	889	1.16	943	1.34	994	1.52	1045	1.71	1096	1.89	1146	2.08	1197	2.27		
2250	511	0.34	573	0.52	638	0.68	708	0.82	776	0.94	839	1.09	896	1.26	948	1.45	998	1.64	1048	1.83	1098	2.01	1149	2.2	1200	2.4		
2500	527	0.44	589	0.62	654	0.78	723	0.91	789	1.05	850	1.21	904	1.39	955	1.58	1003	1.77	1052	1.96	1101	2.14	1152	2.33	1203	2.53		
2750	545	0.55	606	0.72	672	0.88	740	1.03	804	1.17	861	1.34	914	1.53	962	1.72	1010	1.92	1057	2.10	1105	2.29	1154	2.47	1206	2.68		
3000	564	0.66	626	0.84	692	1.01	759	1.16	819	1.32	874	1.49	924	1.68	971	1.88	1017	2.08	1063	2.26	1110	2.44	1158	2.63	1208	2.83		
3250	585	0.79	648	0.98	714	1.14	778	1.31	836	1.48	887	1.66	935	1.86	981	2.06	1026	2.26	1071	2.45	1117	2.63	1163	2.80	1213	3.00		
3500	607	0.93	672	1.13	737	1.31	798	1.48	852	1.66	901	1.85	948	2.05	993	2.26	1037	2.46	1081	2.65	1125	2.83	1171	3.01	1221	3.21		
3750	632	1.10	698	1.31	762	1.50	819	1.67	869	1.86	915	2.05	961	2.25	1005	2.47	1049	2.68	1092	2.88	1136	3.05	1181	3.24	1231	3.45		
4000	660	1.30	726	1.52	787	1.70	838	1.87	885	2.06	930	2.26	974	2.48	1018	2.71	1062	2.93	1105	3.12	1149	3.30	1194	3.49	1245	3.72		
4250	691	1.53	755	1.75	810	1.91	857	2.07	901	2.27	945	2.50	990	2.74	1034	2.98	1077	3.20	1120	3.39	1163	3.58	1210	3.79	1262	4.03		
4500	724	1.78	783	1.98	831	2.12	874	2.28	917	2.50	962	2.75	1006	3.02	1051	3.27	1094	3.49	1137	3.70	1181	3.89	1228	4.11	1281	4.38		
4750	757	2.05	809	2.20	851	2.33	891	2.51	935	2.76	980	3.05	1025	3.33	1070	3.59	1113	3.82	1156	4.03	1201	4.24	1249	4.47	1303	4.75		
5000	787	2.31	831	2.43	870	2.57	910	2.78	954	3.06	1000	3.38	1046	3.68	1091	3.95	1135	4.19	1178	4.40	1224	4.62	1272	4.86	1325	5.13		
5250	814	2.55	852	2.66	889	2.83	930	3.09	975	3.41	1023	3.76	1070	4.08	1115	4.35	1159	4.59	1203	4.81	1248	5.03	1297	5.27	1350	5.53		
5500	835	2.78	871	2.91	909	3.13	952	3.44	999	3.81	1049	4.18	1096	4.51	1142	4.79	1186	5.03	1229	5.24	1275	5.46	1324	5.69	---	---		
5750	854	3.01	890	3.19	930	3.48	977	3.86	1027	4.27	1078	4.66	1126	4.99	1171	5.26	1214	5.49	1258	5.70	---	---	---	---	---	---		
6000	871	3.26	910	3.53	955	3.90	1006	4.34	1060	4.80	1111	5.19	1158	5.51	---	---	---	---	---	---	---	---	---	---	---	---		
6250	890	3.57	934	3.94	985	4.41	1041	4.91	1096	5.38	---	---	---	---	---	---	---	---	---	---	---	---	---	---	---	---		

BLOWER DATA

FACTORY INSTALLED BELT DRIVE KIT SPECIFICATIONS

Motor Efficiency	Nominal hp	Maximum hp	Drive Kit Number	RPM Range
Standard & High	2	2.3	1	590 - 890
Standard & High	2	2.3	2	800 - 1105
Standard & High	2	2.3	3	795 - 1195
Standard	3	3.45	4	730 - 970
Standard	3	3.45	5	940 - 1200
Standard	3	3.45	6	1015 - 1300
High	3	3.45	7	730 - 970
High	3	3.45	8	940 - 1200
High	3	3.45	9	1015 - 1300
Standard	5	5.75	10	900 - 1135
Standard	5	5.75	11	1040 - 1315
Standard	5	5.75	12	1125 - 1425

NOTE - Using total air volume and system static pressure requirements determine from blower performance tables rpm and motor output required. Maximum usable output of motors furnished are shown. In Canada, nominal motor output is also maximum usable motor output. If motors of comparable output are used, be sure to keep within the service factor limitations outlined on the motor nameplate.

NOTE - Units equipped with MSAV® (Multi-Stage Air Volume) option are limited to a motor service factor of 1.0.

POWER EXHAUST FAN PERFORMANCE

Return Air System Static Pressure	Air Volume Exhausted
in. w.g.	cfm
0	3175
0.05	2955
0.10	2685
0.15	2410
0.20	2165
0.25	1920
0.30	1420
0.35	1200

FACTORY INSTALLED OPTIONS/FIELD INSTALLED ACCESSORY AIR RESISTANCE - in. w.g.

Air Volume cfm	Wet Indoor Coil		Electric Heat	Economizer	Humiditrol Condenser Reheat Coil	Filters		Return Air Adaptor Plate
	092, 102	120, 150				MERV 8	MERV 13	
1750	0.04	0.04	0.03	0.05	0.02	0.01	0.03	0.00
2000	0.05	0.05	0.03	0.06	0.02	0.01	0.03	0.00
2250	0.06	0.06	0.04	0.08	0.02	0.01	0.04	0.00
2500	0.07	0.07	0.04	0.11	0.03	0.01	0.05	0.00
2750	0.08	0.08	0.05	0.12	0.03	0.02	0.05	0.00
3000	0.10	0.09	0.06	0.13	0.03	0.02	0.06	0.02
3250	0.11	0.10	0.06	0.15	0.04	0.02	0.06	0.02
3500	0.12	0.11	0.09	0.15	0.04	0.03	0.07	0.04
3750	0.14	0.13	0.09	0.15	0.05	0.03	0.08	0.07
4000	0.15	0.14	0.09	0.19	0.05	0.04	0.08	0.09
4250	0.17	0.15	0.13	0.19	0.06	0.04	0.09	0.11
4500	0.19	0.17	0.14	0.22	0.07	0.04	0.09	0.12
4750	0.20	0.18	0.17	0.25	0.07	0.05	0.10	0.16
5000	0.22	0.20	0.20	0.29	0.08	0.06	0.10	0.18
5250	0.24	0.22	0.22	0.32	0.08	0.06	0.11	0.19
5500	0.25	0.23	0.25	0.34	0.09	0.07	0.12	0.22
5750	0.27	0.25	0.31	0.45	0.10	0.07	0.12	0.25
6000	0.29	0.27	0.33	0.52	0.10	0.08	0.13	0.27

BLOWER DATA

CEILING DIFFUSERS AIR RESISTANCE - in. w.g.

Unit Size	RTD11 Step-Down Diffuser			FD11 Flush Diffuser	
	Air Volume cfm	2 Ends Open	1 Side, 2 Ends Open		All Ends & Sides Open
092 Models	2400	0.21	0.18	0.15	0.14
	2600	0.24	0.21	0.18	0.17
	2800	0.27	0.24	0.21	0.20
	3000	0.32	0.29	0.25	0.25
	3200	0.41	0.37	0.32	0.31
	3400	0.50	0.45	0.39	0.37
	3600	0.61	0.54	0.48	0.44
102 & 120 Models	3800	0.73	0.63	0.57	0.51
	3600	0.36	0.28	0.23	0.15
	3800	0.40	0.32	0.26	0.18
	4000	0.44	0.36	0.29	0.21
	4200	0.49	0.40	0.33	0.24
	4400	0.54	0.44	0.37	0.27
	4600	0.60	0.49	0.42	0.31
	4800	0.65	0.53	0.46	0.35
150 Models	5000	0.69	0.58	0.50	0.39
	5200	0.75	0.62	0.54	0.43
	4200	0.22	0.19	0.16	0.10
	4400	0.28	0.24	0.20	0.12
	4600	0.34	0.29	0.24	0.15
	4800	0.40	0.34	0.29	0.19
	5000	0.46	0.39	0.34	0.23
	5200	0.52	0.44	0.39	0.27
	5400	0.58	0.49	0.43	0.31
5600	0.64	0.54	0.47	0.35	
5800	0.70	0.59	0.51	0.39	

CEILING DIFFUSER AIR THROW DATA

Model No.	Air Volume cfm	¹ Effective Throw Range	
		RTD11 Step-Down	FD11 Flush
		ft.	ft.
092 Models	2600	24 - 29	19 - 24
	2800	25 - 30	20 - 28
	3000	27 - 33	21 - 29
	3200	28 - 35	22 - 29
	3400	30 - 37	22 - 30
102, 120 Models	3600	25 - 33	22 - 29
	3800	27 - 35	22 - 30
	4000	29 - 37	24 - 33
	4200	32 - 40	26 - 35
	4400	34 - 42	28 - 37
150 Models	5600	39 - 49	28 - 37
	5800	42 - 51	29 - 38
	6000	44 - 54	40 - 50
	6200	45 - 55	42 - 51
	6400	46 - 55	43 - 52
6600	47 - 56	45 - 56	

¹ Throw is the horizontal or vertical distance an air stream travels on leaving the outlet or diffuser before the maximum velocity is reduced to 50 ft. per minute. Four sides open.

ELECTRICAL DATA

7.5 TON

Model No.		LCH092H4								
¹ Voltage - 60hz		208/230V - 3 Ph			460V - 3 Ph			575V - 3 Ph		
Compressor 1	Rated Load Amps	13.1			6.1			4.4		
	Locked Rotor Amps	83.1			41			33		
Compressor 2	Rated Load Amps	13.1			6.1			4.4		
	Locked Rotor Amps	83.1			41			33		
Outdoor Fan Motors (2)	Full Load Amps	2.4			1.3			1		
	(total)	(4.8)			(2.6)			(2)		
Power Exhaust (1) 0.33 HP	Full Load Amps	2.4			1.3			1		
Service Outlet 115V GFI (amps)		15			15			20		
Indoor Blower Motor	Horsepower	2	3	5	2	3	5	2	3	5
	Full Load Amps	7.5	10.6	16.7	3.4	4.8	7.6	2.7	3.9	6.1
² Maximum Overcurrent Protection	Unit Only	50	50	60	25	25	30	15	20	20
	With (1) 0.33 HP Power Exhaust	50	60	70	25	25	30	20	20	25
³ Minimum Circuit Ampacity	Unit Only	42	45	52	20	22	25	15	16	19
	With (1) 0.33 HP Power Exhaust	45	48	55	22	23	26	16	17	20

ELECTRIC HEAT DATA

Electric Heat Voltage			208V	240V	208V	240V	208V	240V	480V	480V	480V	600V	600V	600V
² Maximum Overcurrent Protection	Unit+ Electric Heat	7.5 kW	50	50	50	50	60	60	25	25	30	15	20	20
		15 kW	⁴ 50	60	60	60	⁴ 60	70	30	30	35	25	25	30
		22.5 kW	⁴ 70	80	⁴ 80	90	⁴ 80	90	40	40	45	35	35	35
		30 kW	⁴ 90	100	⁴ 100	110	⁴ 100	125	50	60	60	40	45	45
		45 kW	150	150	150	150	⁴ 150	175	80	80	80	60	60	70
³ Minimum Circuit Ampacity	Unit+ Electric Heat	7.5 kW	42	42	45	45	52	52	20	22	25	15	16	19
		15 kW	49	55	53	59	60	66	27	29	33	22	23	26
		22.5 kW	69	78	72	81	80	89	39	40	44	31	32	35
		30 kW	88	100	92	104	100	112	50	52	55	40	41	44
		45 kW	127	145	131	149	139	157	72	74	78	58	60	62
² Maximum Overcurrent Protection	Unit+ Electric Heat and (1) 0.33 HP Power Exhaust	7.5 kW	50	50	60	60	70	70	25	25	30	20	20	25
		15 kW	60	60	⁴ 60	70	70	70	30	35	35	25	25	30
		22.5 kW	⁴ 80	90	⁴ 80	90	⁴ 90	100	40	45	45	35	35	40
		30 kW	⁴ 100	110	⁴ 100	110	⁴ 110	125	60	60	60	45	45	45
		45 kW	150	150	⁴ 150	175	⁴ 150	175	80	80	80	60	70	70
³ Minimum Circuit Ampacity	Unit+ Electric Heat and (1) 0.33 HP Power Exhaust	7.5 kW	45	45	48	48	55	55	22	23	26	16	17	20
		15 kW	52	58	56	62	63	69	29	31	34	23	25	27
		22.5 kW	72	81	75	84	83	92	40	42	45	32	34	36
		30 kW	91	103	95	107	103	115	51	53	57	41	43	45
		45 kW	130	148	134	152	142	160	74	76	79	59	61	64

ELECTRICAL ACCESSORIES

Disconnect	7.5 kW	54W56	54W56	54W56	54W56	54W56	54W56	54W56	54W56	54W56	54W56	54W56	54W56	54W56
	15 kW	54W56	54W56	54W56	54W56	54W56	54W56	54W56	54W56	54W56	54W56	54W56	54W56	54W56
	22.5 kW	54W56	54W56	54W56	54W56	54W57	54W57	54W56	54W56	54W56	54W56	54W56	54W56	54W56
	30 kW	54W57	54W57	54W57	54W57	54W57	54W57	54W56	54W56	54W56	54W56	54W56	54W56	54W56
	45 kW	54W57	54W57	54W57	54W57	54W57	54W57	54W56	54W56	54W56	54W56	54W56	54W56	54W56

NOTE - All units have a minimum Short Circuit Current Rating (SCCR) of 5000 amps.

¹ Extremes of operating range are plus and minus 10% of line voltage.

² HACR type breaker or fuse.

³ Refer to National or Canadian Electrical Code manual to determine wire, fuse and disconnect size requirements.

⁴ Factory installed circuit breaker not available.

ELECTRICAL DATA

8.5 TON

Model No.		LCH102H4								
¹ Voltage - 60hz		208/230V - 3 Ph			460V - 3 Ph			575V - 3 Ph		
Compressor 1	Rated Load Amps	13.7			6.2			4.8		
	Locked Rotor Amps	83.1			41			33		
Compressor 2	Rated Load Amps	13.7			6.2			4.8		
	Locked Rotor Amps	83.1			41			33		
Outdoor Fan Motors (2)	Full Load Amps	2.4			1.3			1		
	(total)	(4.8)			(2.6)			(2)		
Power Exhaust (1) 0.33 HP	Full Load Amps	2.4			1.3			1		
Service Outlet 115V GFI (amps)		15			15			20		
Indoor Blower Motor	Horsepower	2	3	5	2	3	5	2	3	5
	Full Load Amps	7.5	10.6	16.7	3.4	4.8	7.6	2.7	3.9	6.1
² Maximum Overcurrent Protection	Unit Only	50	50	60	25	25	30	20	20	25
	With (1) 0.33 HP Power Exhaust	50	60	70	25	25	30	20	20	25
³ Minimum Circuit Ampacity	Unit Only	44	47	54	20	22	25	16	17	20
	With (1) 0.33 HP Power Exhaust	46	49	56	22	23	26	17	18	21

ELECTRIC HEAT DATA

Electric Heat Voltage			208V	240V	208V	240V	208V	240V	480V	480V	480V	600V	600V	600V
² Maximum Overcurrent Protection	Unit+ Electric Heat	7.5 kW	50	50	50	50	60	60	25	25	30	20	20	25
		15 kW	⁴ 50	60	60	60	⁴ 60	70	30	30	35	25	25	30
		22.5 kW	⁴ 70	80	⁴ 80	90	⁴ 80	90	40	40	45	35	35	35
		30 kW	⁴ 90	100	⁴ 100	110	⁴ 100	125	50	60	60	40	45	45
		45 kW	150	150	150	150	⁴ 150	175	80	80	80	60	60	70
³ Minimum Circuit Ampacity	Unit+ Electric Heat	7.5 kW	44	44	47	47	54	54	20	22	25	16	17	20
		15 kW	49	55	53	59	60	66	27	29	33	22	23	26
		22.5 kW	69	78	72	81	80	89	39	40	44	31	32	35
		30 kW	88	100	92	104	100	112	50	52	55	40	41	44
		45 kW	127	145	131	149	139	157	72	74	78	58	60	62
² Maximum Overcurrent Protection	Unit+ Electric Heat and (1) 0.33 HP	7.5 kW	50	50	60	60	70	70	25	25	30	20	20	25
		15 kW	60	60	⁴ 60	70	70	70	30	35	35	25	25	30
		22.5 kW	⁴ 80	90	⁴ 80	90	⁴ 90	100	40	45	45	35	35	40
	Power Exhaust	30 kW	⁴ 100	110	⁴ 100	110	⁴ 110	125	60	60	60	45	45	45
		45 kW	150	150	⁴ 150	175	⁴ 150	175	80	80	80	60	70	70
³ Minimum Circuit Ampacity	Unit+ Electric Heat and (1) 0.33 HP	7.5 kW	46	46	49	49	56	56	22	23	26	17	18	21
		15 kW	52	58	56	62	63	69	29	31	34	23	25	27
		22.5 kW	72	81	75	84	83	92	40	42	45	32	34	36
	Power Exhaust	30 kW	91	103	95	107	103	115	51	53	57	41	43	45
		45 kW	130	148	134	152	142	160	74	76	79	59	61	64

ELECTRICAL ACCESSORIES

Disconnect	7.5 kW	54W56	54W56	54W56	54W56	54W56	54W56	54W56	54W56	54W56	54W56	54W56	54W56	54W56
	15 kW	54W56	54W56	54W56	54W56	54W56	54W56	54W56	54W56	54W56	54W56	54W56	54W56	54W56
	22.5 kW	54W56	54W56	54W56	54W56	54W57	54W57	54W56	54W56	54W56	54W56	54W56	54W56	54W56
	30 kW	54W57	54W57	54W57	54W57	54W57	54W57	54W56	54W56	54W56	54W56	54W56	54W56	54W56
	45 kW	54W57	54W57	54W57	54W57	54W57	54W57	54W56	54W56	54W56	54W56	54W56	54W56	54W56

NOTE - All units have a minimum Short Circuit Current Rating (SCCR) of 5000 amps.

¹ Extremes of operating range are plus and minus 10% of line voltage.

² HACR type breaker or fuse.

³ Refer to National or Canadian Electrical Code manual to determine wire, fuse and disconnect size requirements.

⁴ Factory installed circuit breaker not available.

ELECTRICAL DATA

10 TON

Model No.		LCH120H4								
¹ Voltage - 60hz		208/230V - 3 Ph			460V - 3 Ph			575V - 3 Ph		
Compressor 1	Rated Load Amps	16			7.8			5.7		
	Locked Rotor Amps	110			52			38.9		
Compressor 2	Rated Load Amps	16			7.8			5.7		
	Locked Rotor Amps	110			52			38.9		
Outdoor Fan Motors (2)	Full Load Amps	2.4			1.3			1		
	(total)	(4.8)			(2.6)			(2)		
Power Exhaust (1) 0.33 HP	Full Load Amps	2.4			1.3			1		
Service Outlet 115V GFI (amps)		15			15			20		
Indoor Blower Motor	Horsepower	2	3	5	2	3	5	2	3	5
	Full Load Amps	7.5	10.6	16.7	3.4	4.8	7.6	2.7	3.9	6.1
² Maximum Overcurrent Protection	Unit Only	60	60	70	30	30	35	20	20	25
	With (1) 0.33 HP Power Exhaust	60	60	70	30	30	35	20	25	25
³ Minimum Circuit Ampacity	Unit Only	49	52	58	24	25	28	18	19	22
	With (1) 0.33 HP Power Exhaust	51	54	61	25	27	30	19	20	23

ELECTRIC HEAT DATA

Electric Heat Voltage			208V	240V	208V	240V	208V	240V	480V	480V	480V	600V	600V	600V
² Maximum Overcurrent Protection	Unit+ Electric Heat	15 kW	60	60	60	60	70	70	30	30	35	25	25	30
		22.5 kW	⁴ 70	80	⁴ 80	90	⁴ 80	90	40	40	45	35	35	35
		30 kW	⁴ 90	100	⁴ 100	110	⁴ 100	125	50	60	60	40	45	45
		45 kW	150	150	150	150	⁴ 150	175	80	80	80	60	60	70
		60 kW	⁴ 150	175	⁴ 150	175	⁴ 150	175	80	80	90	70	70	70
³ Minimum Circuit Ampacity	Unit+ Electric Heat	15 kW	49	55	53	59	60	66	27	29	33	22	23	26
		22.5 kW	69	78	72	81	80	89	39	40	44	31	32	35
		30 kW	88	100	92	104	100	112	50	52	55	40	41	44
		45 kW	127	145	131	149	139	157	72	74	78	58	60	62
		60 kW	135	154	139	158	146	166	77	79	82	62	63	66
² Maximum Overcurrent Protection	Unit+ Electric Heat and (1) 0.33 HP Power Exhaust	15 kW	60	60	⁴ 60	70	70	70	30	35	35	25	25	30
		22.5 kW	⁴ 80	90	⁴ 80	90	⁴ 90	100	40	45	45	35	35	40
		30 kW	⁴ 100	110	⁴ 100	110	⁴ 110	125	60	60	60	45	45	45
		45 kW	150	150	⁴ 150	175	⁴ 150	175	80	80	80	60	70	70
		60 kW	⁴ 150	175	⁴ 150	175	⁴ 150	175	80	80	90	70	70	70
³ Minimum Circuit Ampacity	Unit+ Electric Heat and (1) 0.33 HP Power Exhaust	15 kW	52	58	56	62	63	69	29	31	34	23	25	27
		22.5 kW	72	81	75	84	83	92	40	42	45	32	34	36
		30 kW	91	103	95	107	103	115	51	53	57	41	43	45
		45 kW	130	148	134	152	142	160	74	76	79	59	61	64
		60 kW	138	157	142	161	149	169	79	80	84	63	64	67

ELECTRICAL ACCESSORIES

Disconnect	15 kW	54W56	54W56	54W56	54W56	54W56	54W56	54W56	54W56	54W56	54W56	54W56	54W56	54W56
	22.5 kW	54W56	54W56	54W56	54W56	54W57	54W57	54W56	54W56	54W56	54W56	54W56	54W56	54W56
	30 kW	54W57	54W57	54W57	54W57	54W57	54W57	54W56	54W56	54W56	54W56	54W56	54W56	54W56
	45 kW	54W57	54W57	54W57	54W57	54W57	54W57	54W56	54W56	54W56	54W56	54W56	54W56	54W56
	60 kW	⁵ N/A	⁵ N/A	⁵ N/A	⁵ N/A	⁵ N/A	⁵ N/A	54W56	54W56	⁵ N/A	54W56	54W56	54W56	54W56

NOTE - All units have a minimum Short Circuit Current Rating (SCCR) of 5000 amps.

¹ Extremes of operating range are plus and minus 10% of line voltage.

² HACR type breaker or fuse.

³ Refer to National or Canadian Electrical Code manual to determine wire, fuse and disconnect size requirements.

⁴ Factory installed circuit breaker not available.

⁵ Disconnect must be field furnished.

ELECTRICAL DATA

12.5 TON

Model No.		LCH150H4								
¹ Voltage - 60hz		208/230V - 3 Ph			460V - 3 Ph			575V - 3 Ph		
Compressor 1	Rated Load Amps	19.6			8.2			6.6		
	Locked Rotor Amps	136			66.1			55.3		
Compressor 2	Rated Load Amps	22.4			10.6			7.7		
	Locked Rotor Amps	149			75			54		
Outdoor Fan Motors (2)	Full Load Amps	3.2			1.7			1.5		
	(total)	(6.4)			(3.4)			(3)		
Power Exhaust (1) 0.33 HP	Full Load Amps	2.4			1.3			1		
Service Outlet 115V GFI (amps)		15			15			20		
Indoor Blower Motor	Horsepower	2	3	5	2	3	5	2	3	5
	Full Load Amps	7.5	10.6	16.7	3.4	4.8	7.6	2.7	3.9	6.1
² Maximum Overcurrent Protection	Unit Only	80	80	90	35	35	40	25	30	30
	With (1) 0.33 HP Power Exhaust	80	80	90	35	40	40	30	30	30
³ Minimum Circuit Ampacity	Unit Only	62	65	71	28	30	33	22	23	25
	With (1) 0.33 HP Power Exhaust	64	67	73	30	31	34	23	24	26

ELECTRIC HEAT DATA

Electric Heat Voltage			208V	240V	208V	240V	208V	240V	480V	480V	480V	600V	600V	600V
² Maximum Overcurrent Protection	Unit+ Electric Heat	15 kW	80	80	80	80	90	90	35	35	40	25	30	30
		22.5 kW	80	80	⁴ 80	90	90	90	40	40	45	35	35	35
		30 kW	⁴ 90	100	⁴ 100	110	⁴ 100	125	50	60	60	40	45	45
		45 kW	150	150	150	150	⁴ 150	175	80	80	80	60	60	70
		60 kW	⁴ 150	175	⁴ 150	175	⁴ 150	175	80	80	90	70	70	70
³ Minimum Circuit Ampacity	Unit+ Electric Heat	15 kW	62	62	65	65	71	71	28	30	33	22	23	26
		22.5 kW	69	78	72	81	80	89	39	40	44	31	32	35
		30 kW	88	100	92	104	100	112	50	52	55	40	41	44
		45 kW	127	145	131	149	139	157	72	74	78	58	60	62
		60 kW	135	154	139	158	146	166	77	79	82	62	63	66
² Maximum Overcurrent Protection	Unit+ Electric Heat and (1) 0.33 HP Power Exhaust	15 kW	80	80	80	80	90	90	35	40	40	30	30	30
		22.5 kW	⁴ 80	90	⁴ 80	90	⁴ 90	100	40	45	45	35	35	40
		30 kW	⁴ 100	110	⁴ 100	110	⁴ 110	125	60	60	60	45	45	45
		45 kW	150	150	⁴ 150	175	⁴ 150	175	80	80	80	60	70	70
		60 kW	⁴ 150	175	⁴ 150	175	⁴ 150	175	80	80	90	70	70	70
³ Minimum Circuit Ampacity	Unit+ Electric Heat and (1) 0.33 HP Power Exhaust	15 kW	64	64	67	67	73	73	30	31	34	23	25	27
		22.5 kW	72	81	75	84	83	92	40	42	45	32	34	36
		30 kW	91	103	95	107	103	115	51	53	57	41	43	45
		45 kW	130	148	134	152	142	160	74	76	79	59	61	64
		60 kW	138	157	142	161	149	169	79	80	84	63	64	67

ELECTRICAL ACCESSORIES

Disconnect	15 kW	54W56	54W56	54W56	54W56	54W56	54W56	54W56	54W56	54W56	54W56	54W56	54W56	54W56
	22.5 kW	54W56	54W56	54W56	54W56	54W57	54W57	54W56	54W56	54W56	54W56	54W56	54W56	54W56
	30 kW	54W57	54W57	54W57	54W57	54W57	54W57	54W56	54W56	54W56	54W56	54W56	54W56	54W56
	45 kW	54W57	54W57	54W57	54W57	54W57	54W57	54W56	54W56	54W56	54W56	54W56	54W56	54W56
	60 kW	⁵ N/A	⁵ N/A	⁵ N/A	⁵ N/A	⁵ N/A	⁵ N/A	54W56	54W56	54W57	54W56	54W56	54W56	54W56

NOTE - All units have a minimum Short Circuit Current Rating (SCCR) of 5000 amps.

¹ Extremes of operating range are plus and minus 10% of line voltage.

² HACR type breaker or fuse.

³ Refer to National or Canadian Electrical Code manual to determine wire, fuse and disconnect size requirements.

⁴ Factory installed circuit breaker not available.

⁵ Disconnect must be field furnished.

ELECTRIC HEAT CAPACITIES

Volts Input	7.5 kW			15 kW			22.5 kW			30 kW			45 kW			60 kW		
	kW Input	Btuh Output	No. of Stages	kW Input	Btuh Output	No. of Stages	kW Input	Btuh Output	No. of Stages	kW Input	Btuh Output	No. of Stages	kW Input	Btuh Output	No. of Stages	kW Input	Btuh Output	No. of Stages
208	5.6	19,100	1	11.3	38,600	1	16.9	57,700	2	22.5	76,800	2	33.8	115,300	2	45.0	153,600	2
220	6.3	21,500	1	12.6	43,000	1	18.9	64,500	2	25.2	86,000	2	37.8	129,000	2	50.4	172,000	2
230	6.9	23,600	1	13.8	47,100	1	20.7	70,700	2	27.5	93,900	2	41.3	141,000	2	55.1	188,000	2
240	7.5	25,600	1	15.0	51,200	1	22.5	76,800	2	30.0	102,400	2	45.0	153,600	2	60.0	204,800	2
440	6.9	21,500	1	12.6	43,000	1	18.9	64,500	2	25.2	86,000	2	37.8	129,000	2	50.4	172,000	2
460	6.9	23,600	1	13.8	47,100	1	20.7	70,700	2	27.5	93,900	2	41.3	141,000	2	55.1	188,000	2
480	7.5	25,600	1	15.0	51,200	1	22.5	76,800	2	30.0	102,400	2	45.0	153,600	2	60.0	204,800	2
550	6.3	21,500	1	12.6	43,000	1	18.9	64,500	2	25.2	86,000	2	37.8	129,000	2	50.4	172,000	2
575	6.9	23,600	1	13.8	47,100	1	20.7	70,700	2	27.5	93,900	2	41.3	141,000	2	55.1	188,000	2
600	7.5	25,600	1	15.0	51,200	1	22.5	76,800	2	30.0	102,400	2	45.0	153,600	2	60.0	204,800	2

UNIT CLEARANCES

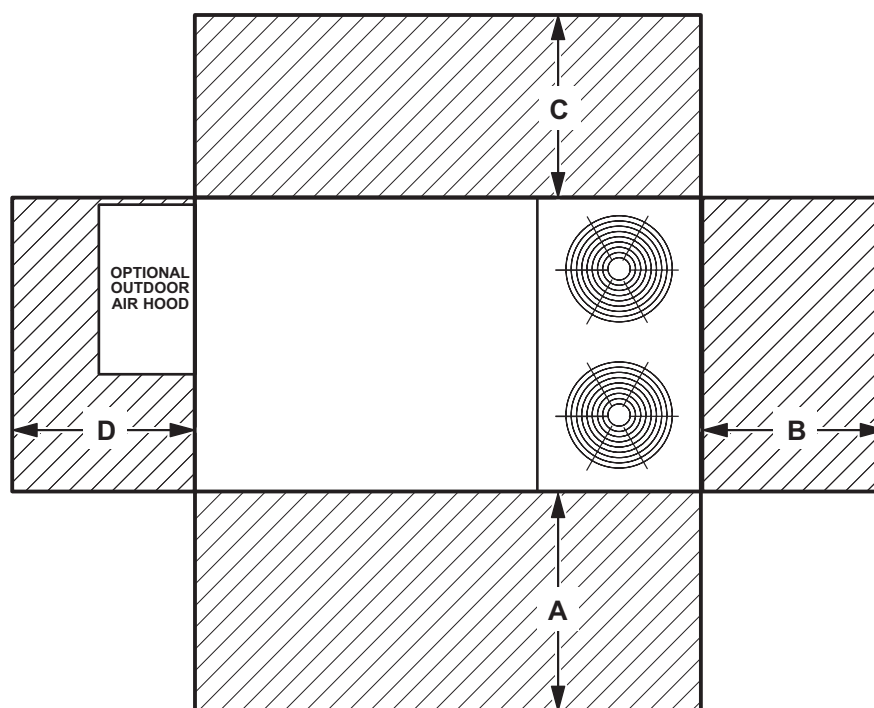

¹ Unit Clearance	A		B		C		D		Top Clearance
	in.	mm	in.	mm	in.	mm	in.	mm	
Service Clearance	60	1524	36	914	36	934	60	1524	Unobstructed
Minimum Operation Clearance	36	914	36	914	36	914	36	914	

NOTE - Entire perimeter of unit base requires support when elevated above the mounting surface.

¹ Service Clearance - Required for removal of serviceable parts.

Minimum Operation Clearance - Required clearance for proper unit operation.

OUTDOOR SOUND DATA

Unit Model Number	Octave Band Sound Power Levels dBA, re 10 ⁻¹² Watts - Center Frequency - Hz							¹ Sound Rating Number (dBA)
	125	250	500	1000	2000	4000	8000	
092, 102 and 120	76	79	84	83	79	73	66	88
150	75	81	87	85	80	74	70	90

Note - The octave sound power data does not include tonal corrections.

¹ Sound Rating Number according to AHRI Standard 370-2001 (includes pure tone penalty). Sound Rating Number is the overall A-Weighted Sound Power Level, (LWA), dBA (100 Hz to 10,000 Hz).

WEIGHT DATA

Model Number	Outdoor Coil	Net		Shipping		Outdoor Coil	Net		Shipping	
		lbs.	kg	lbs.	kg		lbs.	kg	lbs.	kg
092 Base Unit	Environ	1040	472	1125	510	Fin/Tube	1120	508	1205	547
092 Max. Unit	Environ	1197	543	1282	582	Fin/Tube	1277	579	1362	618
102 Base Unit	Environ	1047	475	1132	513	Fin/Tube	1127	511	1212	550
102 Max. Unit	Environ	1204	546	1289	585	Fin/Tube	1284	582	1369	621
120 Base Unit	Environ	1082	491	1167	529	Fin/Tube	1162	527	1247	566
120 Max. Unit	Environ	1246	565	1331	604	Fin/Tube	1326	601	1411	640
150 Base Unit	N/A	---	---	---	---	Fin/Tube	1165	528	1250	567
150 Max. Unit	N/A	---	---	---	---	Fin/Tube	1315	596	1400	635

OPTIONS / ACCESSORIES

Description	Shipping Weight	
	lbs.	kg
CONVENTIONAL FIN/TUBE CONDENSER COIL		
Fin/Tube Condenser Coil (092-102-120 Models Only)	80	36
ECONOMIZER / OUTDOOR AIR / EXHAUST		
Economizer		
Economizer Dampers	60	27
Outdoor Air Hood (downflow)	23	10
Barometric Relief Dampers (downflow)	8	4
Barometric Relief Dampers (low profile horizontal)	20	9
Outdoor Air Dampers		
Outdoor Air Damper Section - Automatic	51	23
Outdoor Air Damper Section - Manual	39	18
Power Exhaust	31	14
ELECTRIC HEAT		
7.5 kW	50	23
15 kW	50	23
22.5 kW	57	26
30 kW	57	26
45 kW	59	27
60 kW	68	31
HUMIDITROL® DEHUMIDIFICATION SYSTEM		
Humiditrol Dehumidification Option	20	9
MSAV (MULTI-STAGE AIR VOLUME) SUPPLY AIR BLOWER OPTION		
Variable Frequency Drive (VFD) and associated components	10	5
ROOF CURBS		
Hybrid Roof Curbs, Downflow		
8 in. height	60	27
14 in. height	85	39
18 in. height	100	45
24 in. height	125	57
Adjustable Pitch Curb, Downflow		
14 in. height	191	82
CEILING DIFFUSERS		
Step-Down		
RTD11-95S	118	54
RTD11-135S	135	61
RTD11-185S	168	76
Flush		
FD11-95S	118	54
FD11-135S	135	61
FD11-185S	168	76
Transitions		
C1DIFF30B-1	30	14
C1DIFF31B-1	32	15
C1DIFF32B-1	36	16
PACKAGING		
LTL Packaging (less than truck load)	105	48

DIMENSIONS - UNIT

Model No.	CORNER WEIGHTS																CENTER OF GRAVITY							
	AA				BB				CC				DD				EE				FF			
	Base		Max.		Base		Max.		Base		Max.		Base		Max.		Base		Max.		Base		Max.	
	lbs.	kg	lbs.	kg	lbs.	kg	lbs.	kg	lbs.	kg	lbs.	kg	lbs.	kg	lbs.	kg	in.	mm	in.	mm	in.	mm	in.	mm
092	281	127	327	148	252	114	286	130	275	125	306	139	312	142	358	162	46.5	1181	45.5	1156	24.5	622	25.5	648
102	282	128	329	149	254	115	287	130	276	125	308	139	314	143	360	163	46.5	1181	45.5	1156	24.5	622	25.5	648
120	294	133	340	154	264	120	297	135	283	128	318	144	321	146	372	169	46.5	1181	45.5	1156	24.5	622	25.5	648
150	304	138	350	159	273	124	306	139	293	133	327	148	332	151	383	174	46.5	1181	45.5	1156	24.5	622	25.5	648

Base Unit - The unit with NO INTERNAL OPTIONS.

Max. Unit - The unit with ALL INTERNAL OPTIONS Installed. (Economizer, Standard Static Power Exhaust Fans, Controls, etc.). Does not include accessories external to unit or high static power exhaust.

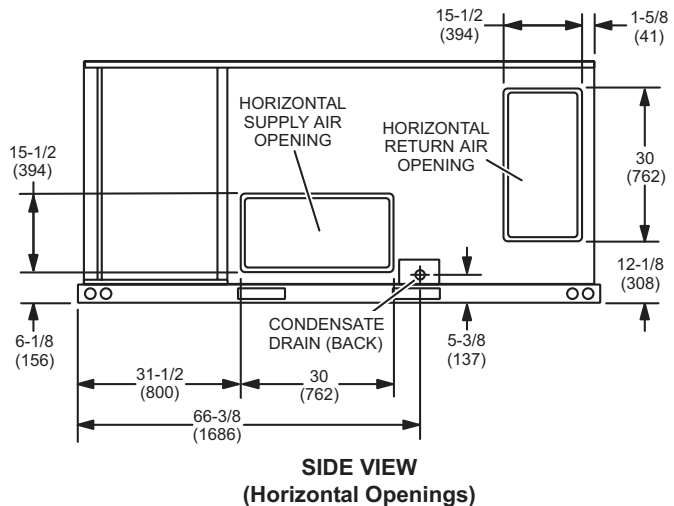
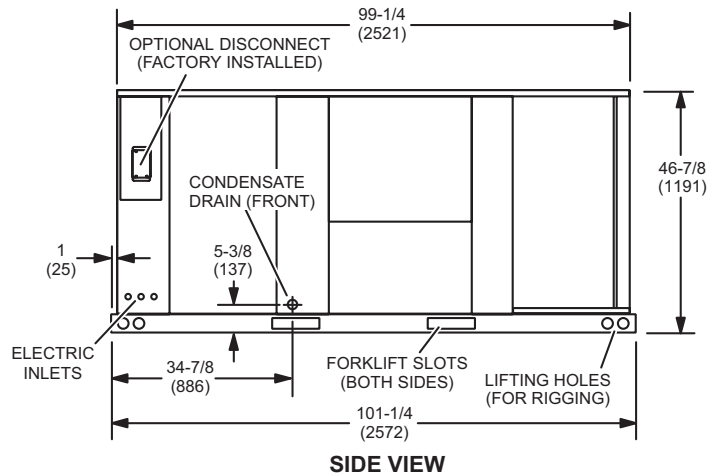
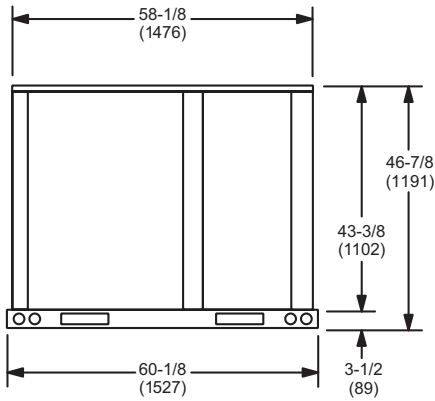
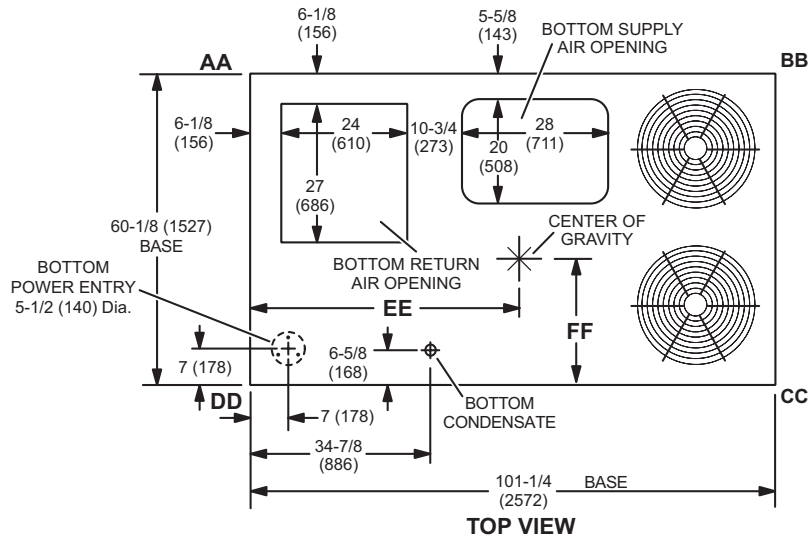

OUTDOOR AIR HOOD DETAIL

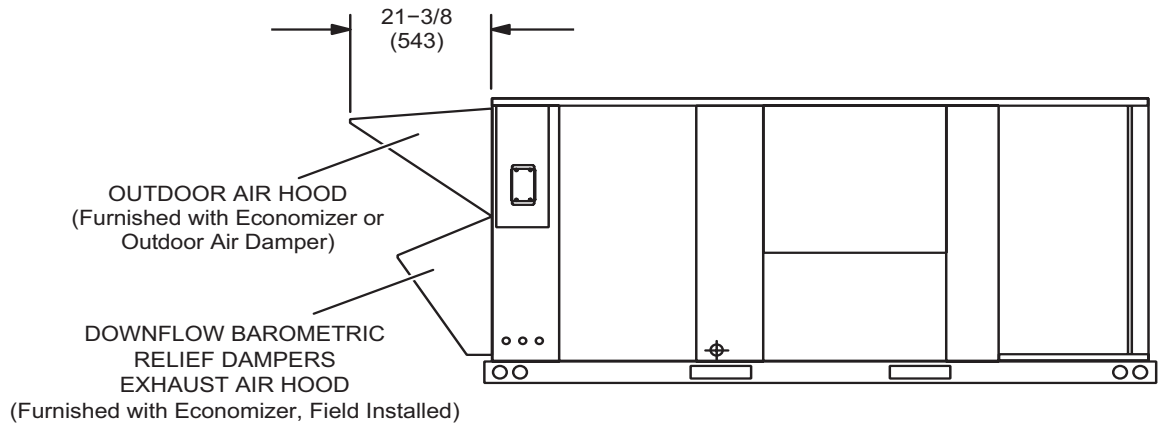

DIMENSIONS - ACCESSORIES

HORIZONTAL ECONOMIZER APPLICATION

(With Furnished Barometric Relief Dampers and Optional Horizontal Discharge Kit - Required)

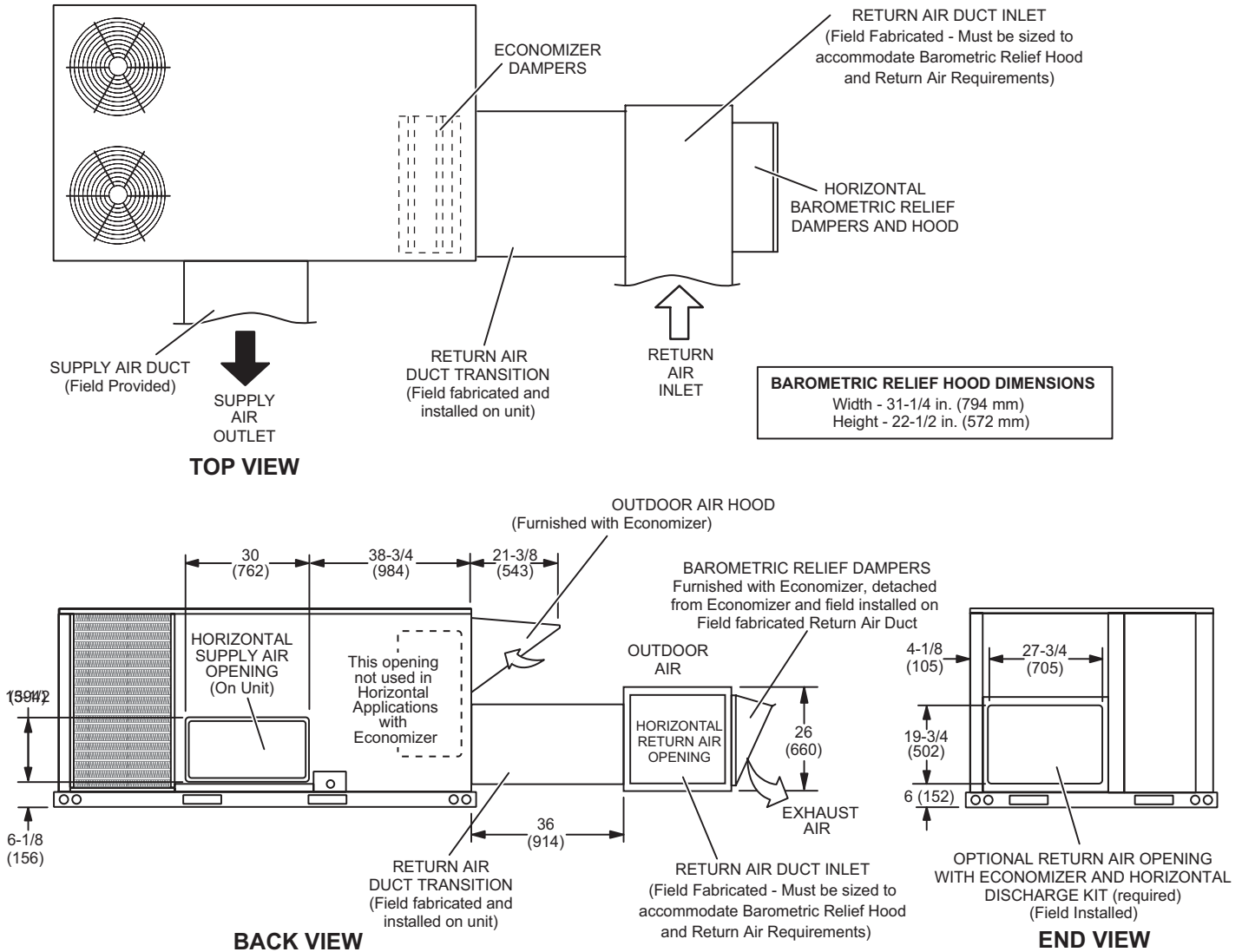

NOTE - Return Air Duct and Transition must be supported.

BAROMETRIC RELIEF DAMPERS (Furnished with Economizer)

(Field installed in horizontal return air duct adjacent to unit)

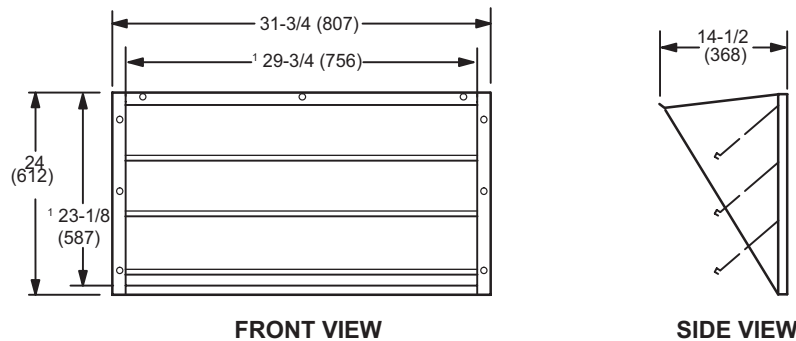

NOTE - Opening size required in return air duct.

DIMENSIONS - ACCESSORIES

HORIZONTAL ECONOMIZER APPLICATION

(with Optional Low Profile Horizontal Barometric Relief Dampers and Horizontal Discharge Kit - Required)

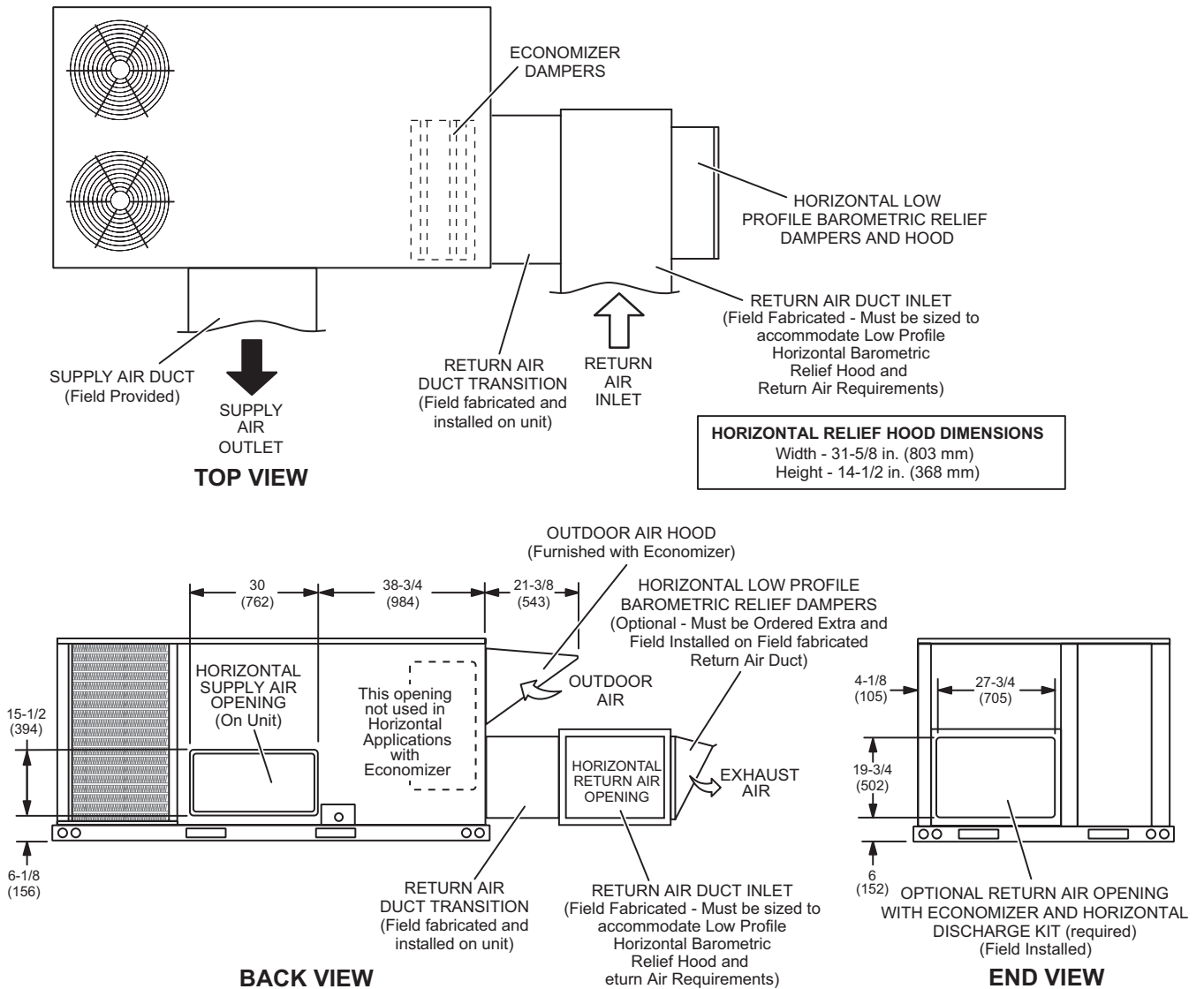

NOTE - Return Air Duct and Transition must be supported.

HORIZONTAL LOW PROFILE BAROMETRIC RELIEF DAMPERS (Field installed in horizontal return air duct adjacent to unit)

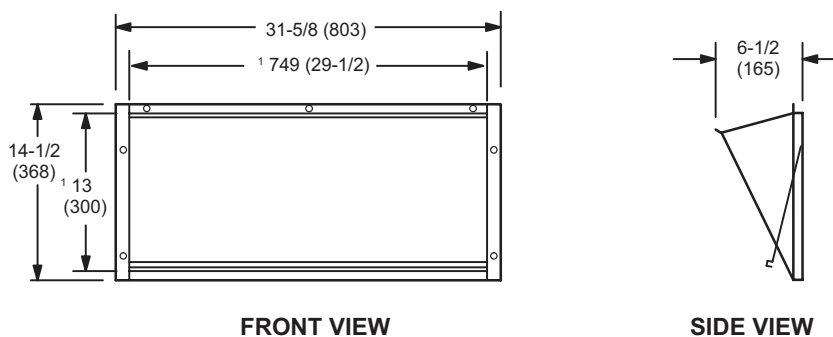

¹ NOTE - Opening size required in return air duct.

DIMENSIONS - ACCESSORIES

HYBRID ROOF CURBS - DOUBLE DUCT OPENING

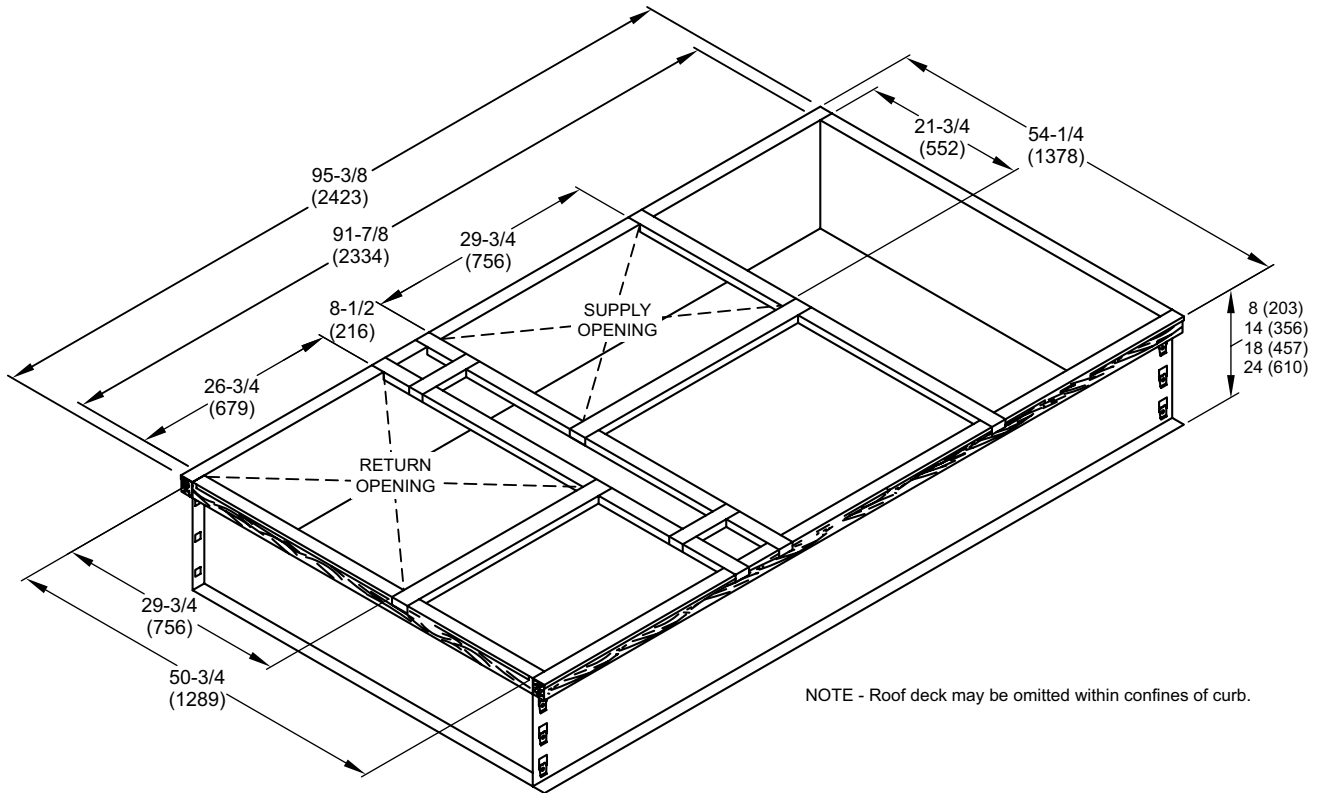

TYPICAL FLASHING DETAIL FOR ROOF CURB

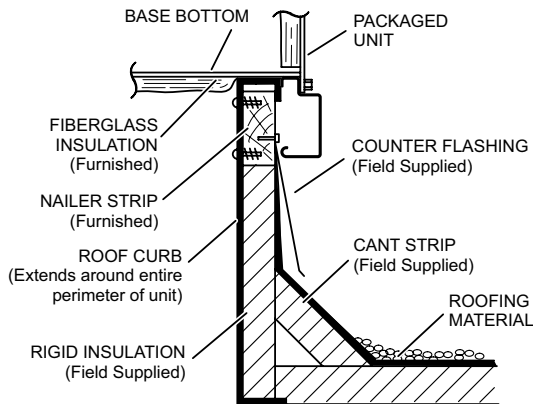

DETAIL ROOF CURB

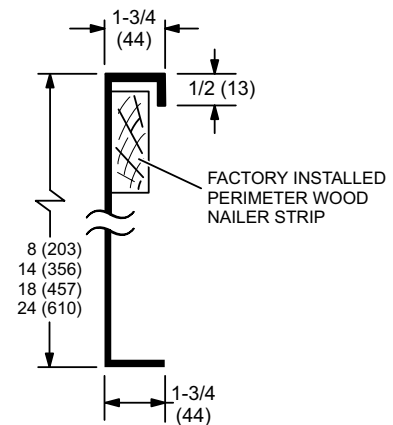

ADJUSTABLE PITCH CURBS - DOUBLE DUCT OPENING

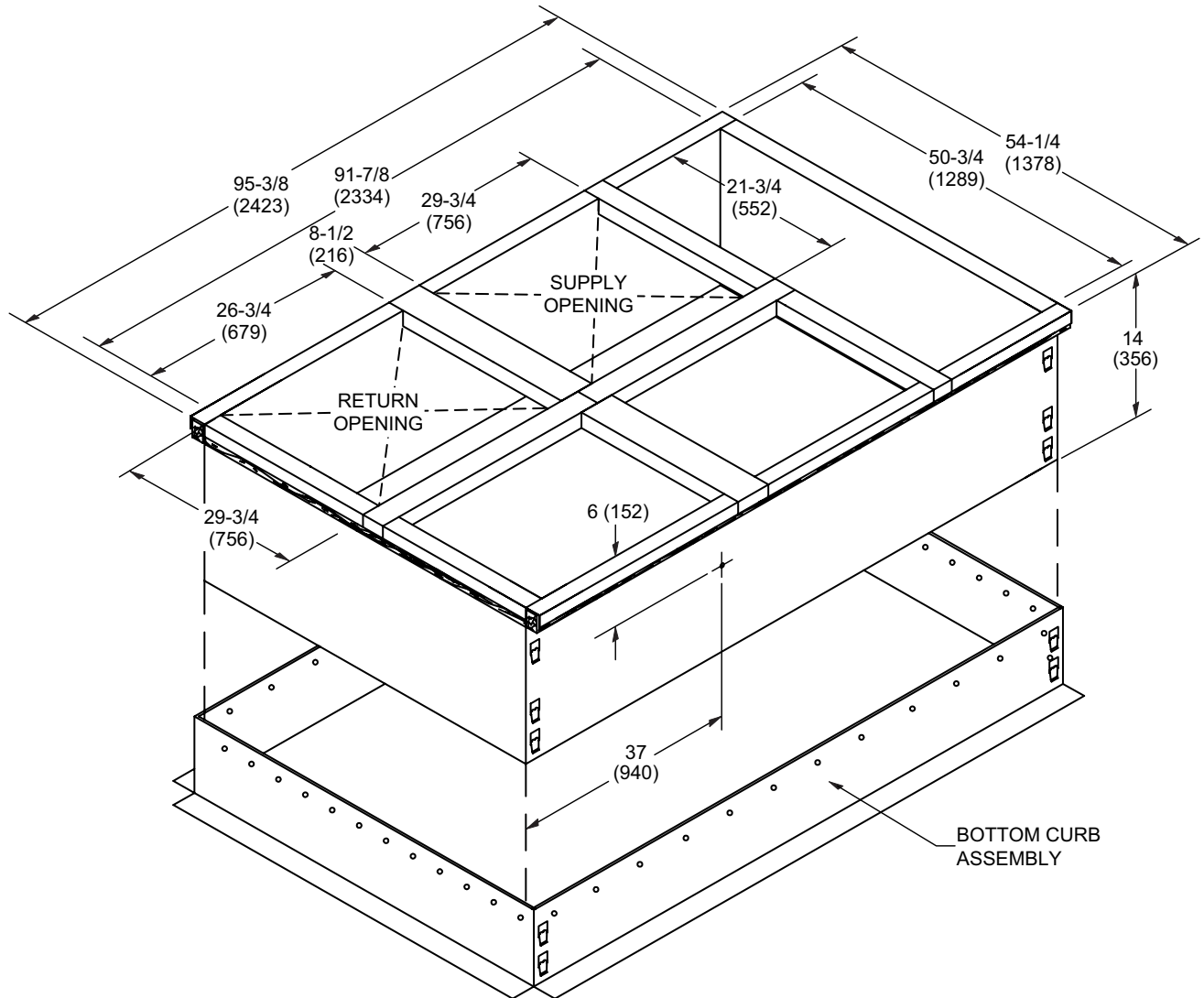

NOTE - Maximum slope pitch is 3/4 in. per 1 foot (19 mm per 305 mm) in any one direction.

TYPICAL FLASHING DETAIL FOR ROOF CURB

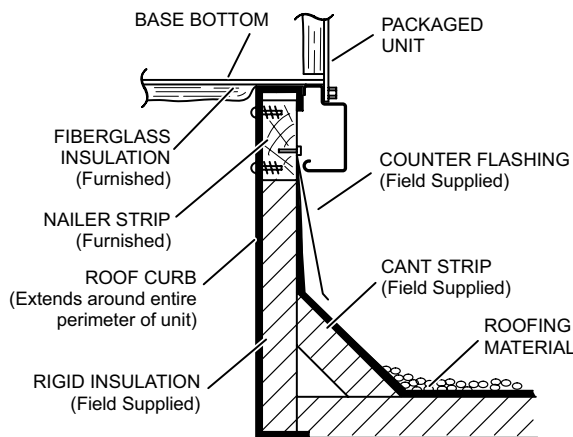

DETAIL ROOF CURB

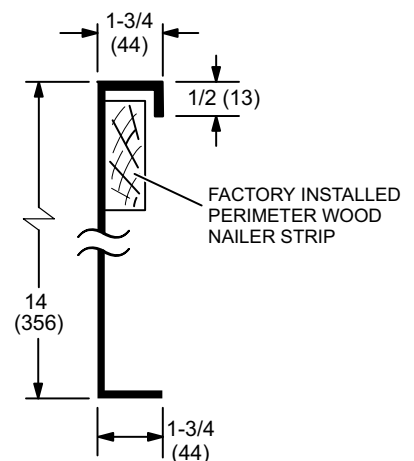

ROOF CURBS WITH SUPPLY & RETURN AIR TRANSITIONS FOR CEILING DIFFUSERS

C1DIFF30B-1 ROUND TRANSITIONS
(for 092 models)

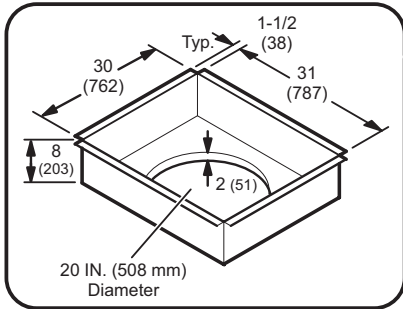

C1DIFF31B-1 & C1DIFF32B-1 RECTANGULAR TRANSITIONS
(for 102 thru 150 models)

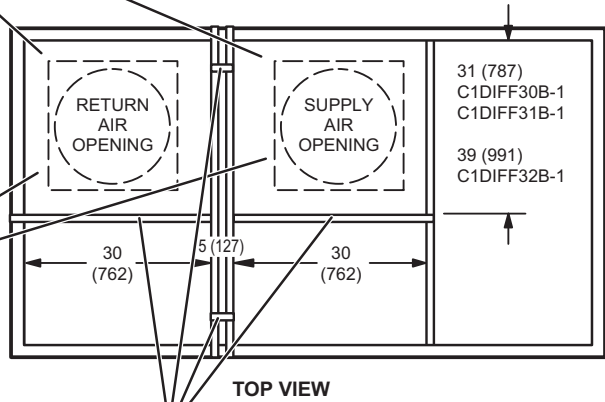
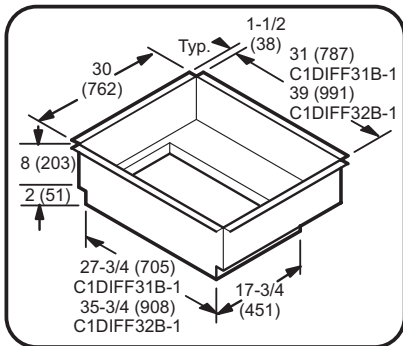

TOP VIEW

NOTE - These four supports are furnished with the transitions to replace supports furnished with curb for proper transition spacing.

DIMENSIONS - ACCESSORIES

COMBINATION CEILING SUPPLY AND RETURN DIFFUSERS

STEP-DOWN CEILING DIFFUSER

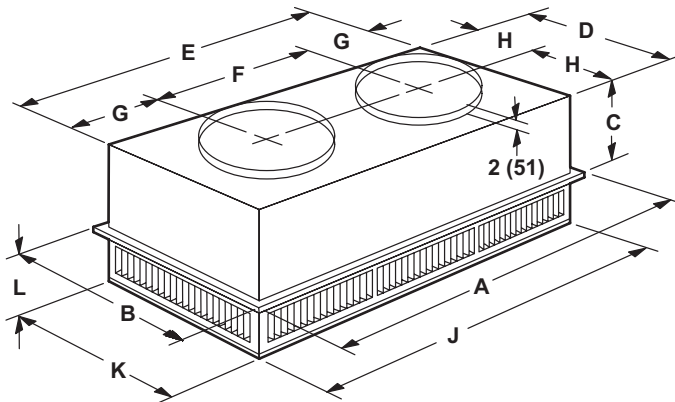

FLUSH CEILING DIFFUSER

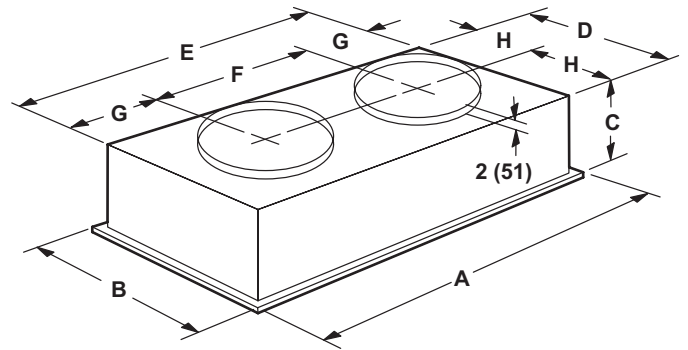

Model Number		RTD11-95S
A	in.	47-5/8
	mm	1159
B	in.	29-5/8
	mm	752
C	in.	14-3/8
	mm	365
D	in.	27-1/2
	mm	699
E	in.	45-1/2
	mm	1158
F	in.	22-1/2
	mm	572
G	in.	11-1/2
	mm	292
H	in.	13-3/4
	mm	349
J	in.	45-1/2
	mm	1156
K	in.	27-1/2
	mm	699
L	in.	8-1/8
	mm	206
Duct Size	in.	20 round
	mm	508 round

Model Number		FD11-95S
A	in.	47-5/8
	mm	1159
B	in.	29-5/8
	mm	752
C	in.	16-5/8
	mm	422
D	in.	27
	mm	686
E	in.	45
	mm	1143
F	in.	22-1/2
	mm	572
G	in.	11-1/4
	mm	286
H	in.	13-1/2
	mm	343
Duct Size	in.	20 round
	mm	508 round

DIMENSIONS - ACCESSORIES

COMBINATION CEILING SUPPLY AND RETURN DIFFUSERS

STEP-DOWN CEILING DIFFUSER

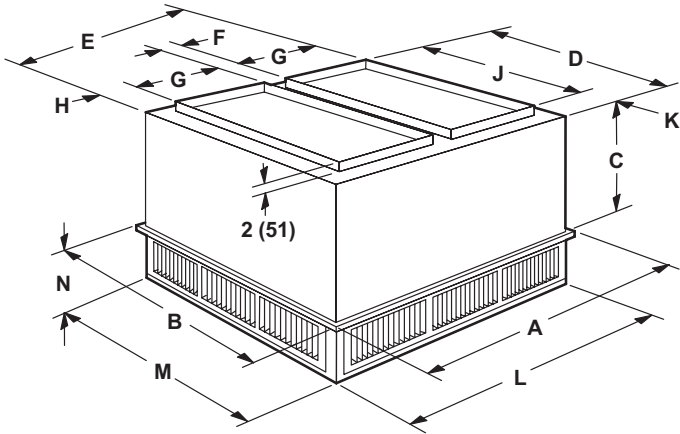

FLUSH CEILING DIFFUSER

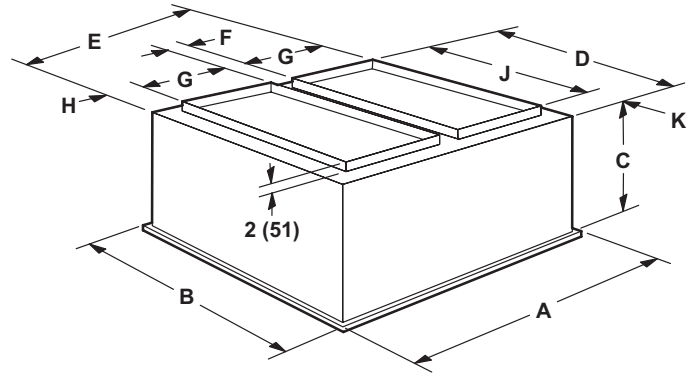

Model Number		RTD11-135S	RTD11-185S
A	in.	47-5/8	47-5/8
	mm	1210	1210
B	in.	35-5/8	47-5/8
	mm	905	1210
C	in.	20-5/8	24-5/8
	mm	524	625
D	in.	33-1/2	45-1/2
	mm	851	1156
E	in.	45-1/2	45-1/2
	mm	1156	1156
F	in.	4-1/2	4-1/2
	mm	114	114
G	in.	18	18
	mm	457	457
H	in.	2-1/2	2-1/2
	mm	64	64
J	in.	28	36
	mm	711	914
K	in.	2-3/4	4-3/4
	mm	70	121
L	in.	45-1/2	45-1/2
	mm	1156	1156
M	in.	33-1/2	45-1/2
	mm	851	1156
N	in.	9-1/8	10-1/8
	mm	232	257
Duct Size	in.	18 x 28	18 x 36
	mm	457 x 711	457 x 914

Model Number		FD11-135S	FD11-185S
A	in.	47-5/8	47-5/8
	mm	1210	1210
B	in.	35-5/8	47-5/8
	mm	905	1210
C	in.	23-1/4	29-1/4
	mm	591	743
D	in.	33	45
	mm	838	1143
E	in.	45	45
	mm	1143	1143
F	in.	4-1/2	4-1/2
	mm	114	114
G	in.	18	18
	mm	457	457
H	in.	2-1/4	2-1/4
	mm	57	57
J	in.	28	36
	mm	711	914
K	in.	2-1/2	4-1/2
	mm	64	114
Duct Size	in.	18 x 28	18 x 36
	mm	457 x 711	457 x 914

REVISIONS

Section	Description
Electrical Data	Updated for LCH092, 102 models.
Specifications	Refrigerant charge updated for LCH092, 102 models.

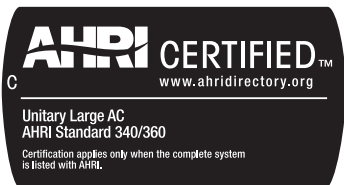

Visit us at www.lennox.com

For the latest technical information, www.lennoxcommercial.com

Contact us at 1-800-4-LENNOX

NOTE - Due to Lennox' ongoing commitment to quality, Specifications, Ratings and Dimensions subject to change without notice and without incurring liability. Improper installation, adjustment, alteration, service or maintenance can cause property damage or personal injury. Installation and service must be performed by a qualified installer and servicing agency.

©2020 Lennox Industries, Inc.