



LCH
Energence® Ultra-High Efficiency Rooftop Units
60 Hz

COMMERCIAL
PRODUCT SPECIFICATIONS

Bulletin No. 210686
 March 2021
 Supersedes August 2019



SMARTWIRE™ SYSTEM



ASHRAE 90.1
COMPLIANT



7.5 to 12.5 Tons
Net Cooling Capacity - 92,000 to 138,000 Btuh
Optional Electric Heat - 7.5 to 60 kW

MODEL NUMBER IDENTIFICATION

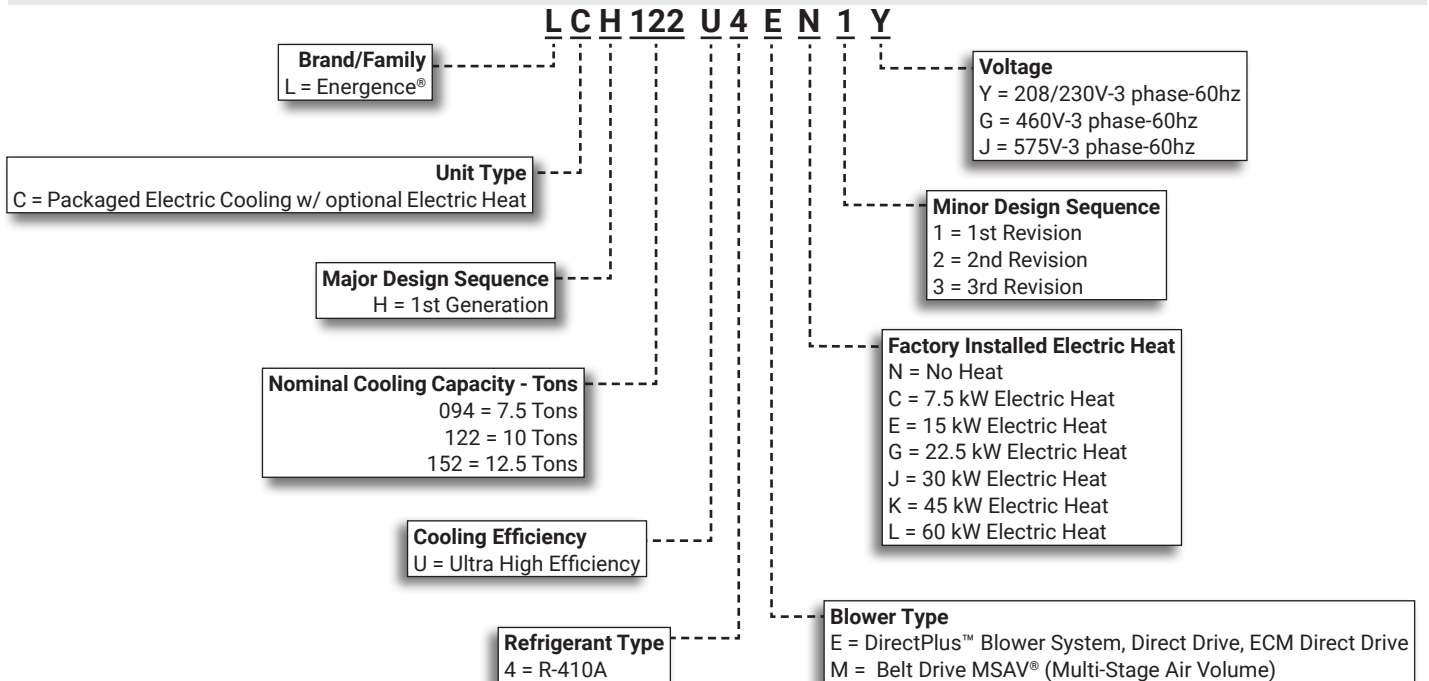

FEATURE HIGHLIGHTS

Lennox' Emergence® Ultra- High Efficiency packaged rooftop unit product line was created to save energy with intelligence by offering some of the highest energy efficiency ratings available with a powerful, easy to use unit controller. This makes Emergence rooftop units perfect for business owners looking for an HVAC product with the lowest total cost of ownership.

1. Tandem Scroll Compressors
2. Condenser Coil
3. Variable-Speed ECM Outdoor Coil Fan Motors
4. Heavy Gauge Steel Cabinet
5. Hinged Access Panels
6. DirectPlus™ Direct Drive ECM or MSAV® (Multi-Stage Air Volume) Belt Drive Blower Motor
7. Electric Heat (option)
8. GFI Service Outlets (option)
9. Air Filters
10. Prodigy® Control System

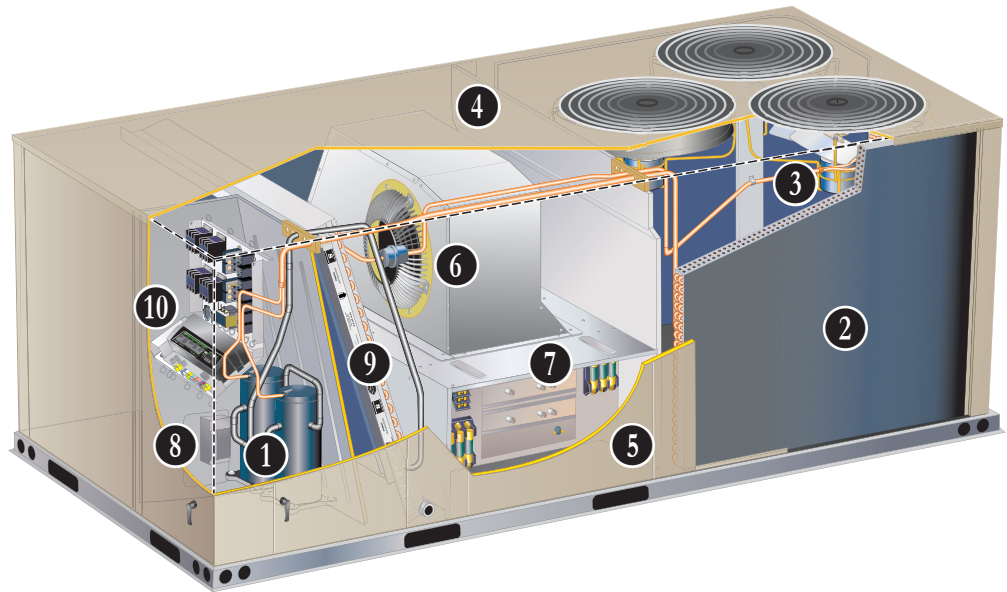

CONTENTS

Approvals And Warranty	3
Blower Data	30
Control System	8
Dimensions - Accessories	45
Dimensions - Unit	44
Electrical/Electric Heat Data	35
Features And Benefits	3
Model Number Identification.	1
Options / Accessories	21
Outdoor Sound Data	42
Ratings	28
Sequence Of Operation.	14
Specifications	26
Unit Clearances	41
Weight Data	42

APPROVALS AND WARRANTY

APPROVALS

- AHRI Standard 340/360 certified
- ETL and CSA listed
- CSA certified energy ratings
- Unit and components ETL, NEC and CEC bonded for grounding to meet safety standards for servicing
- All models are ASHRAE 90.1-2010 energy efficiency compliant and meet or exceed requirements of Section 6.8
- All models meet DOE 2018 energy efficiency standards
- All models meet California Code of Regulations, Title 24 and ASHRAE 90.1-2010 Section 6.4.3.10 requirements for staged airflow
- ENERGY STAR® certified
- ISO 9001 Registered Manufacturing Quality System

WARRANTY

- Compressors - Limited five years
- Prodigy® 2.0 Unit Controller - Limited three years
- Optional High Performance Economizers - Limited five years
- All other covered components - Limited one year

FEATURES AND BENEFITS

COOLING SYSTEM

- Designed to maximize sensible and latent cooling performance at design conditions
- System can operate from 0°F to 125°F without any additional controls

R-410A Refrigerant

- Non-chlorine based
- Ozone friendly

1 Tandem Scroll Compressors

- Scroll compressors on all models for high performance, reliability and quiet operation
- Advanced cooling system design features tandem compressors arranged in one single circuit system operate together or independently depending on load requirements
- Compressors utilize the maximum area of the coils for maximum heat transfer
- Advanced algorithms in the Prodigy® Control System manage compressor run-times to even the load between the system when running at part-load conditions
- Slide-out compressor tray allows easy access for servicing
- Compressors and tray are resiliently mounted on rubber grommets for quiet operation

Compressor Crankcase Heaters

- Protects against refrigerant migration that can occur during low ambient operation or during extended off cycles

Dual-Flow Thermal Expansion Valve System

- Assures optimal performance throughout the application range
- Removable element head
- Dual valve assembly with flow control

Filter/Drier

- High capacity filter/drier protects the system from dirt and moisture

High Pressure Switches

- Protects the compressor from overload conditions such as dirty condenser coils, blocked refrigerant flow, or loss of outdoor fan operation

Low Pressure Switch

- Protects the compressors from low pressure conditions such as low refrigerant charge, or low/no airflow

Freezestat

- Protects the evaporator coil from damaging ice build-up due to conditions such as low/no airflow, or low refrigerant charge

2 Condenser Coil

- Copper tube construction
- Enhanced rippled-edge aluminum fins
- Flared shoulder tubing connections
- Silver soldered construction

Evaporator Coil

- Copper tube construction
- Enhanced rippled-edge aluminum fins
- Flared shoulder tubing connections
- Silver soldered construction
- Cross row circuiting with rifled copper tubing

Condensate Drain Pan

- Plastic pan, sloped to meet drainage requirements per ASHRAE 62.1
- Side or bottom drain connections
- Reversible to allow connection at back of unit

FEATURES AND BENEFITS

COOLING SYSTEM (continued)

3 Variable-Speed ECM Outdoor Coil Fan Motors

- Fan speed is directly controlled by the Prodigy® 2.0 unit controller
- Thermal overload protected
- Totally enclosed
- Permanently lubricated ball bearings
- Shaft up
- Wire basket mount

Outdoor Coil Fans

- PVC coated fan guard furnished

Required Selections

Cooling Capacity

- Specify nominal cooling capacity

Options/Accessories

Factory or Field Installed

Condensate Drain Trap

- Available in copper or PVC
- Field installed only, may be factory ordered to ship with unit

Drain Pan Overflow Switch

- Monitors condensate level in drain pan
- Shuts down unit if drain becomes clogged

CABINET

4 Construction

- Heavy-gauge steel panels
- Full perimeter heavy-gauge galvanized steel base rail
- Base rails have rigging holes
- Three sides of the base rail have forklift slots
- Raised edges around duct and power entry openings in the bottom of the unit for water protection

Airflow Choice

- Units are shipped in downflow (vertical) return air flow configuration

NOTE - Units can be field converted to horizontal airflow with optional Horizontal Discharge Kit.

Duct Flanges

- Provided for horizontal duct attachment

Power Entry

- Electrical lines can be brought through the unit base or through horizontal access knock-outs

Exterior Panels

- Constructed of heavy-gauge, galvanized steel
- Two-layer enamel paint finish

Insulation

- Fully insulated with non-hygroscopic fiberglass insulation (conditioned areas)
- Unit base is fully insulated

- Base insulation serves as an air seal to the roof curb, eliminating the need to add a seal during installation

5 Hinged Access Panels

- Tool-less access
- Filter section
- Blower/heating section
- Compressor/controls section
- Panel seals and quarter-turn latching handles provide a tight air and water seal

Required Selections

Airflow Configuration

- Specify downflow or horizontal

Options/Accessories

Factory or Field Installed

Return Air Adaptor Plate

- For same size LC/LG/LH and TC/TG/TH unit replacement
- Installs on return air opening in unit to match return air opening on existing roof curbs
- Also see Accessory Air Resistance table

Factory Installed

Corrosion Protection

- Completely flexible immersed coating
- Electrodeposited dry film process
- AST ElectroFin E-Coat
- Meets Mil Spec MIL-P-53084, ASTM B117 Standard Method Salt Spray Testing
- Indoor Corrosion Protection:
 - Coated coil
 - Painted blower housing
 - Painted base
- Outdoor Corrosion Protection:
 - Coated coil
 - Painted outdoor base

Field Installed

Combination Coil/Hail Guards

- Heavy gauge steel frame
- Painted to match cabinet
- Expanded metal mesh protects outdoor coil

Horizontal Discharge Kit

- Consists of duct covers to block off downflow supply and return air openings for horizontal applications
- Also includes return air duct flanges for end return air when economizer is used in horizontal applications

NOTE - When configuring unit for horizontal application with economizer, a separate Horizontal Barometric Relief Damper with Hood must be ordered separately for installation in the return air duct.

FEATURES AND BENEFITS

BLOWER

- 6 A full selection of supply air blower options are available to meet a variety of airflow requirements.

DirectPlus™ Direct Drive ECM Blower System

- High-efficiency, variable-speed ECM (electronically commutated) motor
- Aerodynamically optimized impeller
- Backward curved blades mounted directly onto the rotor
- Combines the motor and electronics into one unit
- Eliminates the need for a separate variable-frequency drive
- Ramps the blower up or down to meet comfort needs
- Blower assembly slides out of unit for servicing



- Air inlet grill reduces indoor sound levels without affecting air performance

MSAV® (Multi-Stage Air Volume) Belt Drive Blower System

- Stages the amount of airflow according to compressor stages, heating demand, ventilation demand or smoke alarm
- Utilizes a Variable Frequency Drive (VFD) to stage the supply blower airflow
- The VFD alters the frequency and voltage of the power supply to the blower to control blower speed
- The amount of airflow for each stage can be set according to a parameter in the Prodigy 2.0 unit controller
- Unit is shipped from the factory with preset airflow
- Can be ordered with or without an Electronic Bypass Control
- Bypass control features manual (default) or automatic electronic bypass control of the VFD
- In case of a VFD malfunction, a VFD alarm is generated by the Prodigy® 2.0 unit controller
- VFD can be manually bypassed to continue unit operation at full blower speed
- Unit controller can be set to automatically switch to full blower speed if a VFD alarm is generated
- The VFD has an operational range of 0 to 125°F outdoor air ambient temperature
- Lower operating costs are obtained when the blower is operated on lower speeds
- Overload protected
- Equipped with ball bearings
- Forward curved blades
- Double inlet
- Blower wheel is statically and dynamically balanced
- Ball bearings
- Adjustable pulley (allows speed change during commissioning)

- Blower assembly slides out of unit for servicing
- Blower motor available in several different sizes to maximize air performance

NOTE - Part load airflow in cooling mode should not be set below 160 cfm/nominal full load ton to reduce the risk of evaporator coil freeze-up.

NOTE - All blower motors 5 hp and above meet minimum energy efficiency standards in accordance with the Energy Independence and Security Act (EISA) of 2007.

NOTE - Units equipped with a Variable Frequency Drive (VFD) are designed to operate on balanced, three-phase power. Operating units on unbalanced three-phase power will reduce the reliability of all electrical components in the unit. Unbalanced power is a result of the power delivery system supplied by the local utility company. Factory-installed inverters are sized to drive blower motors with an equivalent current rating using balanced three-phase power. If unbalanced three-phase power is supplied; the installer must replace the existing factory-installed inverter with an inverter that has a higher current rating to allow for the imbalance. Refer to the installation instructions for additional information and replacement information.

Required Selections

Blower Selection

- Select DirectPlus™ Direct Drive ECM or MSAV® (Multi-Stage Air Volume) Belt Drive Option
- Belt Drive - Specify motor horsepower and drive kit number when base unit is ordered

Options/Accessories

Factory Installed

Blower Belt Auto-Tensioner

- Provides proper tension to belt drive blower belt without the need for regular adjustments
- Maintains airflow and proper performance

FEATURES AND BENEFITS

ELECTRICAL

SmartWire™ System

- Keyed and color-coded wiring connectors prevent miswiring
- Wire coloring scheme is standardized across all models
- Each connection is intuitively labeled to make troubleshooting and servicing quick and easy

Electrical Plugs

- Positive connection electrical plugs are used to connect common accessories or maintenance parts for easy removal or installation

Phase/Voltage Detection

- Monitors power supply to assure phase is correct at unit start-up
- If phase is incorrect, the unit will not start and an alarm code is reported to the unit controller
- Protects unit from being started with incorrect phasing which could lead to issues such as compressors running backwards
- Voltage detection monitors power supply voltage to assure proper voltage
- If voltage is not correct (over/under voltage conditions) the unit will not start and an alarm code is reported to the unit controller

Required Selections

Voltage Choice

- Specify when ordering base unit

Options/Accessories

Factory Installed

Circuit Breakers

- HACR type
- Overload and short circuit protection
- Factory wired and mounted in the power entry panel
- Current sensitive and temperature activated
- Manual reset

SCR (Silicon Controlled Rectifier) Electric Heat Control

- Modulates small, precise increments of power to the electric heat load eliminating temperature fluctuations associated with mechanical controls
- Almost instantaneous operation with no moving parts
- Zero-Cross (fast cycling) feature improves electric heater life with less contraction and expansion of the heating elements
- The SCR operates when there is no call for heat from the building control system or thermostat
- SCR air tempering is controlled by a secondary thermostat and remote duct sensor (ordered separately)
- A call for heat overrides the SCR and modulates the SCR to 100% heat output
- A call for cooling overrides the SCR

NOTE - The SCR option is not available with 45 kW and 60 kW electric heat (208/230V) models.

NOTE - Blower Proving Switch is required and must be ordered separately for factory installation. See Controls in the Options/Accessories table.

NOTE - Available for use with conventional thermostat controls or Novar® control systems only.

Short-Circuit Current Rating (SCCR)

- Higher short-circuit protection up to 100kA

NOTE - Disconnect Switch not available with higher SCCR option. Short-Circuit Current Rating option not available on field installed electric heat.

Factory or Field Installed

Disconnect Switch

- Accessible outside of unit
- Spring loaded weatherproof cover furnished

7 Electric Heat

- Helix wound nichrome elements
- Individual element limit controls
- Wiring harness
- Unit fuse block
- See Options/Accessories tables for ordering information

8 GFI Service Outlets (2)

- 115V ground fault circuit interrupter (GFCI) type
- Non-powered, field-wired

Field Installed

GFI Weatherproof Cover

- Single-gang cover
- Heavy-duty UV-resistant polycarbonate case construction
- Hinged base cover with gasket

FEATURES AND BENEFITS

INDOOR AIR QUALITY

9 Air Filters

- Disposable 2-inch filters furnished as standard

Options/Accessories

Factory or Field Installed

Healthy Climate® High Efficiency Air Filters

- Disposable MERV 8 or MERV 13 (Minimum Efficiency Reporting Value based on ASHRAE 52.2) efficiency 2-inch pleated filters

Replacement Filter Media Kit With Frame

- Replaces existing pleated filter media
- Includes washable metal mesh screen and metal frame with clip for holding replaceable non-pleated filter

Field Installed

Healthy Climate® UVC Germicidal Lamps

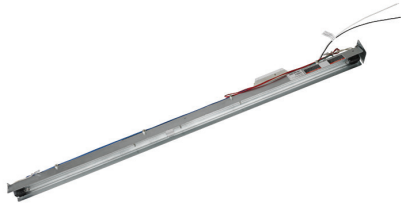

- Germicidal lamps emit ultra-violet (UV-C) energy, which has been proven to be effective in reducing microbes such as viruses, bacteria, yeasts, and molds
- This process either destroys the organism or controls its ability to reproduce
- UV-C energy greatly reduces the growth and proliferation of mold and other bioaerosols (bacteria and viruses) on illuminated surfaces (particularly coil and drain pan)
- Field installed in the blower/evaporator coil section
- Magnetic safety interlock terminates power when access panels are removed
- All necessary hardware for installation is included
- Lamps operate on 110/230V, 1 phase power supply

NOTE - Step-down transformer may be ordered separately for 460V and 575V units.

- Approved by ETL

Indoor Air Quality (CO₂) Sensors

- Monitors CO₂ levels, reports to the Prodigy® 2.0 unit controller which adjusts economizer dampers as needed

CONTROL SYSTEM

PRODIGY® CONTROL SYSTEM



10 The Prodigy 2.0 unit controller is a microprocessor-based controller that provides flexible control of all unit functions.

Features:

- LCD Display
- Easy to read menu (4 lines x 20 character display)
- Buttons for menu navigation during setup and diagnostic
- Menu navigation LEDs for Data, Setup, Service, Settings
- Main Menu and Help Buttons for quick navigation to home screen and built-in help functions
- Scroll, Value Adjustment Select and Save Buttons
- Setup menu insures proper installation and simplified setup of the rooftop unit
- Profile setup copies key settings between units with the same configuration to reduce setup time
- USB port allows a technician to download and transfer unit information to help verify service was performed
- USB software updates on the Prodigy Control System enhance functionality without the need to change components
- Unit Controller Software
- Unit self-test verifies individual critical component and system performance
- Economizer test function assures economizer is operating correctly
- Time Clock with Run-Time Information

Built-In Functions Include:

- Adjustable Blower On/Off Delay
- Built-in Control Parameter Defaults
- Compressor Time-Off Delay
- DDC Compatible
- Dirty Filter Switch Input
- Discharge Air Temperature Control
- Display/Sensor Readout
- Economizer Control Options (See Economizer / Exhaust Air / Outdoor Air sections)
- Fresh Air Tempering
- Over 100 diagnostic and status messages in English
- Exhaust Fan Control Modes for fresh air damper position
- Permanent Diagnostic Code Storage
- Field Adjustable Control Parameters (Over 200 settings)
- Indoor Air Quality Input (Demand Control Ventilation)
- Low Ambient Controls for cooling operation down to 0°F
- Gas Valve Time Delay Between First and Second Stage
- Minimum Compressor Run Time
- Network Capable (Can be daisy chained to other units or controls)
- Night Setback Mode
- Return Air Temperature Limit Control
- Safety Switch Input allows Controller to respond to a external safety switch trip
- Service Relay Output
- Smoke Alarm Mode has four choices (unit off, positive pressure, negative pressure, purge)
- Up to 2 heat/2 cool (standard Prodigy Prodigy unit controller thermostat input)
- Up to 3 cool with additional relay
- Up to 4 cool with room sensor or network operation
- "Strike Three" Protection
- Gas Reheat Control allows simultaneous heating and cooling operation for humidity control of process air applications such as supermarkets
- On Demand Dehumidification monitors and controls condenser hot gas reheat operation with Humiditrol® dehumidification option
- Thermostat Bounce Delay
- Warm Up Mode Delay
- LED Indicators
- PC Interface connects the Prodigy 2.0 unit controller to a PC with the Lennox Unit Controller Software
- Room Sensor Operation controls temperature

NOTE - Prodigy Control System features shown vary with the type of rooftop unit in which the control is installed.

NOTE - See separate Prodigy Control System Product Specifications Bulletin for additional information.

CONTROL SYSTEM

PRODIGY® CONTROL SYSTEM (continued)

Controls Options

Factory or Field Installed

Blower Proving Switch

- Monitors blower operation, shuts down unit if blower fails

Dirty Filter Switch

- Senses static pressure increase indicating dirty filter condition

Fresh Air Tempering

- Used in applications with high outside air requirements
- Controller energizes the first stage heat as needed to maintain a minimum supply air temperature for comfort, regardless of the thermostat demand
- When ordered as a factory option, sensor ships with the unit for field installation

Smoke Detector

- Photoelectric type
- Installed in supply air section, return air section or both sections
- Available with power board and single sensor (supply or return) or power board and two sensors (supply and return)
- Power board located in unit control compartment

Interoperability via BACnet® or LonTalk® Protocols

- Communication compatible with third-party automation systems that support the BACnet Application Specific Controller device profile, LonMark® Space Comfort Controller functional profile, or LonMark Discharge Air Controller functional profile

Commercial Control Systems

L Connection® Network Control System

- Complete building automation control system for single or multi-zone applications
- Options include local interface, software for local or remote communication, and hardware for networking other control functions
- See L Connection Network Control System Product Specifications Bulletin for details

After-Market DDC

- Novar® Unit Controller and options

Thermostats

- Control system and thermostat options
- After-Market unit controller options, see page 12

Field Installed

General Purpose Control Kit

- Plug-in control provides additional analog and digital inputs/outputs for field installed options

ECONOMIZER

- Economizer operation is set and controlled by the Prodigy 2.0 unit controller
- Simple plug-in connections from economizer to unit controller for easy installation
- All Emergence rooftop units are equipped with factory installed CEC Title 24 approved sensors for outside, return and discharge air temperature monitoring

NOTE - Optional sensors may be used instead of unit sensors to determine whether outdoor air is suitable for free cooling. See Options/Accessories table.

Factory or Field Installed

High Performance Economizer

- Approved for California Title 24 building standards
- Low leakage dampers are Air Movement and Control Association International (AMCA) Class 1A Certified - Maximum 3 CFM per sq. ft. leakage at 1 in. w.g.
- ASHRAE 90.1-2010 compliant
- Downflow or Horizontal with Outdoor Air Hood
- Outdoor Air Hood is included when economizer is factory installed and is furnished with economizer when ordered for field installation
- Downflow Barometric Relief Dampers with Exhaust Hood is also furnished
- Gear-driven action
- High torque 24-volt fully-modulating spring return damper motor
- Return air and outdoor air dampers
- Plug-in connections to unit
- Stainless steel bearings
- Enhanced thermoplastic vulcanizate (TPV) seals
- Flexible stainless steel jamb seals

NOTE - High Performance Economizers are not approved for use with enthalpy controls in Title 24 applications.

NOTE - The Free Cooling setpoint for Title 24 applications must be set based on the Climate Zone where the system is installed. See Section 140.4 "Prescriptive Requirements for Space Conditioning Systems" of the California Energy Commission's 2013 Building Energy Efficiency Standards.

NOTE - Refer to Installation Instructions for complete setup information.

OPTIONS / ACCESSORIES

ECONOMIZER (continued)

Differential Sensible Control

- Factory setting
- Uses outdoor air and return air sensors that are furnished with the unit
- The Prodigy® 2.0 unit controller compares outdoor air temperature with return air
- When the outdoor air is below the configured setpoint and cooler than return air, the controller activates the economizer

NOTE - Differential Sensible Control can be configured in the field to provide Offset Differential Sensible Control or Single Sensible Control.

NOTE - In Offset Differential Sensible Control mode, the economizer is enabled if the temperature differential (offset) between outdoor air and return air reaches the configured setpoint. In Single Sensible Control mode, the economizer is enabled when outdoor air temperature falls below the configured setpoint.

Global Control

- The unit controller communicates with a DDC system with one global sensor (enthalpy or sensible)
- Determines whether outside air is suitable for free cooling on all units connected to the control system
- Sensor must be field provided

Factory or Field Installed

Single Enthalpy Temperature Control (Not for Title 24)

- Outdoor air enthalpy sensor enables Economizer if the outdoor enthalpy is less than the setpoint of the control

Differential Enthalpy Control (Not for Title 24)

- Order two Single Enthalpy Controls
- One is field installed in the return air section
- One is installed in the outdoor air section
- Allows the economizer control to select between outdoor air or return air, whichever has lower enthalpy

Field Installed

Outdoor Air CFM Control

- Maintains constant outdoor air volume levels on the supply air fan and varying unit airflows
- Velocity sensor located in the rooftop unit outdoor air section, the Prodigy® 2.0 unit controller changes the economizer position to help minimize the effect of supply fan speed changes on outdoor air volume levels
- Setpoint for outdoor air volume is established by field testing

NOTE - Not available with Demand Control Ventilation (CO₂ Sensor) or Building Pressure Control.

Building Pressure Control

- Maintains constant building pressure level
- Includes a static pressure transducer and outdoor static pressure assembly
- Using differential pressure information between the outdoor air and the building air, the Prodigy® 2.0 unit controller changes the economizer position to help maintain a constant building pressure

NOTE - Not available with Demand Control Ventilation (CO₂ Sensor) or Outdoor Air CFM Control.

EXHAUST

Factory or Field Installed

Power Exhaust Fan

- Installs internal to unit for downflow applications only with economizer option
- Provides exhaust air pressure relief
- Interlocked to run when supply air blower is operating,
- Fan runs when outdoor air dampers are 50% open (adjustable)
- Motor is overload protected
- Fan is 20 in. diameter
- Five blades
- One 1/3 hp motor

NOTE - Requires Economizer and Downflow Barometric Relief Dampers.

Field Installed

Horizontal Low Profile Barometric Relief Dampers

- For use when unit is configured for horizontal applications requiring an economizer
- Allows relief of excess air
- Aluminum blade dampers prevent blow back and outdoor air infiltration during off cycle
- Field installed in return air duct
- Bird screen and hood furnished

NOTE - Requires Horizontal Discharge Kit.

OUTDOOR AIR

Factory or Field Installed

Outdoor Air Damper

- Downflow or Horizontal
- Linked mechanical dampers
- 0 to 25% (fixed) outdoor air adjustable
- Installs in unit
- Includes outdoor air hood
- Automatic model features fully modulating spring return damper motor with plug-in connection
- Manual model features parallel blade, gear-driven dampers with adjustable fixed position

OPTIONS / ACCESSORIES

ROOF CURBS

Field Installed

- Nailer strip furnished (downflow only)
- Mates to unit
- US National Roofing Contractors Approved
- Shipped knocked down

Hybrid Roof Curbs, Downflow

- Interlocking tabs fasten corners together
- No tools required
- Can also be fastened together with furnished hardware
- Available in 8, 14, 18, and 24 inch heights

Adjustable Pitch Curb

- Fully adjustable pitch curbs (3/4 in. per foot in any direction) provide a level platform for rooftop units allowing flexible installations on roofs with uneven or sloped angles
- Uses interlocking tabs to fasten corners together; no tools required
- Hardware is furnished to connect upper curb with lower curb
- Available in 14 inch height

Adaptor Curbs (not shown)

- Curbs are regionally sourced
- Dimensions vary based upon the source

NOTE - Contact your local sales representative for a detailed cut sheet with applicable dimensions.

CEILING DIFFUSERS

Field Installed

Ceiling Diffusers (Flush or Step-Down)

- White powder coat finish on diffuser face and grilles
- Insulated UL listed duct liner
- Diffuser box has collars for duct connection
- Step-down diffusers have double deflection blades
- Flush diffusers have fixed blades
- Provisions for suspending
- Internally sealed to prevent recirculation
- Removable return air grille
- Adapts to T-bar ceiling grids or plaster ceilings

Transitions (Supply and Return)

- Used with diffusers
- Installs in roof curb
- Galvanized steel construction
- Flanges furnished for duct connection to diffusers
- Fully insulated

OPTIONAL CONVENTIONAL TEMPERATURE CONTROL SYSTEMS

ComfortSense® 8500 Commercial 7-Day Programmable Thermostat

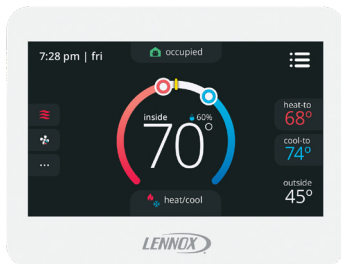

- Fully Communicating Sensor
- Full Color Touchscreen Interface
- Variable Speed System Control (On Compatible Units)
- Up To 4 Heat / 4 Cool
- Built-In Sensors For Temperature, Humidity And Optional CO₂
- Remote Sensor Options For Occupancy, Temperature
- BACnet Capable Options
- 5-2 or 7-Day Scheduling
- Smooth Setback Recovery
- Heat/Cool Auto-Changeover
- Four-Wire Installation
- FDD, ASHRAE, IECC Compliant

ComfortSense® 7500 Commercial 7-Day Programmable Thermostat



- Premium Universal Thermostat
- Full Color Touchscreen Interface
- Up To 4 Heat / 4 Cool
- Built-In Sensors For Temperature and Humidity
- Remote Sensors Options For Temperature, Discharge Air, Outdoor Air
- 5-2 or 7-Day Scheduling
- Smooth Setback Recovery
- Heat/Cool Auto-Changeover
- FDD, ASHRAE, IECC Compliant

ComfortSense® 3000 Commercial 5-2 Day Programmable Thermostat

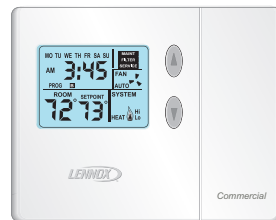

- Conventional Multi-Stage Thermostat
- Intuitive Display
- Push-Button Operation
- Up To 2 Heat / 2 Cool
- Built-In Temperature Sensor
- Remote Temperature Sensing
- Up to 5-2 Day Scheduling
- Smooth Setback Recovery
- Heat/Cool Auto-changeover

Wired Room Sensor (LCS-5030)



- Simple Push-Button Override
- Variable Speed System Control (On Compatible Units)
- Up To 4 Heat / 4 Cool
- Built-In Temperature and Humidity Sensors
- AA Battery / 24VAC Powered
- SBUS Wired Operation
- Automatic Sensor Averaging
- Locking Hex Screw

OPTIONAL CONVENTIONAL TEMPERATURE CONTROL SYSTEMS

Description	Catalog No.
ComfortSense® 8500 Commercial 7 Day Programmable Thermostat	
CS8500 7-Day Thermostat	No CO ₂ Sensing 17G75
	With CO ₂ Sensing 17G76
Sensors/Accessories	¹ Remote non-adjustable wall-mount 10k 47W37
	¹ Remote non-adjustable wall-mount 11k 94L61
Sysbus Network Cable (Yellow) for ComfortSense 8500 and LCS-5030 Wired Room Sensor	
Twisted pair 100% shielded communication cable, Red and Black	500 ft. box 27M19
22 AWG, yellow jacket, rated at 75°C, 300V, Plenum rated	1000 ft. box 94L63
Insulation - Low smoke PVC, NEC, CMP	2500 ft. roll 68M25
ComfortSense® 7500 Commercial 7-Day Programmable Thermostat	
CS7500 7-Day Thermostat	17G74
Sensors/Accessories	² Remote non-adjustable wall-mount 20k 47W36
	² Remote non-adjustable wall-mount 10k 47W37
	Remote non-adjustable discharge air (duct mount) 19L22
	Outdoor temperature sensor X2658
ComfortSense® 3000 Commercial 5-2 Day Programmable Thermostat	
CS3000 5-2 Day Thermostat	11Y05
Sensors/Accessories	Remote non-adjustable wall mount 10k averaging 47W37
	Thermostat wall mounting plate X2659
ComfortSense® Non-Programmable Thermostat	
CS3000 Non-Programmable Thermostat	51M32
Universal Thermostat Guard with Lock (clear)	
	Inside Dimensions (H x W) 5 7/8 x 8 3/8 in. 39P21
Wired Room Sensor	
LCS-5030 Wired Room Sensor	21L07

¹ Up to nine of the same type remote temperature sensors can be connected in parallel.

² Remote wall-mount sensors can be applied in any of the following combinations:
 One Sensor - (1) 47W36, Two Sensors - (2) 47W37, Three Sensors - (2) 47W36 and (1) 47W37
 Four Sensors - (4) 47W36, Five Sensors - (3) 47W36 and (2) 47W37

SEQUENCE OF OPERATION

HEATING MODE (ELECTRIC HEAT)

NOTE - Heating Mode Is The Same For All Control Options.

W1 Demand:

Electric heat energized (stage 1 on units with 2-stage) and supply air blower operates at heating speed.

W2 Demand:

Electric heat energized (stage 2 on units with 2-stage) and supply air blower operates at heating speed.

Modulating Outdoor Air Damper

The minimum damper position for “occupied low blower” and “occupied high blower” is adjusted during unit setup to provide minimum fresh air requirements per ASHRAE 62.1 at the corresponding supply air blower speeds.

When supply air blower is off or the unit is in unoccupied mode, the outdoor air damper is closed.

When unit is in occupied mode and supply air blower is operating at a speed below the “midpoint” blower speed, the outdoor air damper is at minimum “low blower” position.

When unit is in occupied mode and supply air blower is operating at a speed equal to or above the “midpoint” blower speed, the outdoor air damper is at minimum “high blower” position.

NOTE - The “midpoint” blower speed is an average of the minimum and maximum blower speed (minimum speed + maximum speed divided by 2).

THERMOSTAT MODE

The thermostat mode has specific sequence-of-operation scenarios for Lennox’ Ultra-High Efficiency product line. The standard thermostat mode will typically allow 2 stages of heating and cooling operation. Units with a globally-controlled economizer option can have 2 stages of mechanical cooling and free cooling economizer operation. The MSAV® (Multi-Stage Air Volume) blower will also allow up to 5 different supply blower speed values: 2 speed values for cooling mode, 1 speed value for heating mode, 1 speed value for ventilation, and an extra speed for when one of the smoke alarm options is used. When using the factory default, the smoke alarm mode will turn off the blower. It is important to note that the unit controller merely passes along the instructions to provide heating, cooling, or other unit operations.

SEQUENCE OF OPERATION

THERMOSTAT MODE - MSAV® (MULTI-STAGE AIR VOLUME) OPERATION WITH 2-STAGE THERMOSTAT

SUPPLY AIR BLOWER SPEED

Unit has following supply air blower speed setting:

- Ventilation speed
- Heating speed
- Cooling Speed - Low
- Cooling Speed - High
- Smoke speed (Used only in smoke removal option - not discussed)

¹ Unit Features An Economizer And Outdoor Air Is Suitable

Cooling - Thermostat Mode (Y1, Y2)

Y1 Demand:

All compressors are off, supply air blower is on low cooling speed to minimize blower power consumption, economizer modulates (minimum to maximum open position) to maintain 55°F supply air temperature (default unit controller setting).

Y2 Demand:

All compressors are off, supply air blower is on high cooling speed providing higher cooling capacity, and economizer modulates to maintain 55°F supply air temperature.

If economizer stays at maximum open for 3 minutes, compressor 1 is energized while supply air blower stays on high cooling speed providing maximum cooling capacity.

¹ *Outdoor air suitability is determined by the energy state of outdoor ambient (enthalpy or sensible) and its ability to achieve the desired free cooling effects. Outdoor air suitability can also be determined by a third party controller and provided to the rooftop unit via a network connection.*

Unit Does Not Feature An Economizer or Outdoor Air Is Not Suitable

Y1 Demand:

One compressor operates and supply air blower operates at low cooling speed.

Y2 Demand:

All compressors operate and supply air blower operates at high cooling speed.

SEQUENCE OF OPERATION

THERMOSTAT MODE - MSAV® (MULTI-STAGE AIR VOLUME) OPERATION WITH 3-STAGE THERMOSTAT (continued)

SUPPLY AIR BLOWER SPEED

Unit has following supply air blower speed setting:

- Ventilation speed
- Heating speed
- Cooling Speed - Low
- Cooling Speed - High
- Smoke speed (Used only in smoke removal option - not discussed)

¹ Unit Features An Economizer And Outdoor Air Is Suitable

Cooling - Thermostat or Zone Sensor Mode (Y1, Y2, Y3)

Y1 Demand:

All compressors are off, supply air blower is on low cooling speed to minimize blower power consumption, economizer modulates (minimum to maximum open position) to maintain 55°F supply air temperature (default unit controller setting).

Y2 Demand:

All compressors are off, supply air blower is on high cooling speed providing higher cooling capacity, and economizer modulates to maintain 55°F supply air temperature.

If economizer stays at maximum open for 3 minutes, compressor 1 is energized while supply air blower stays on high cooling speed providing maximum cooling capacity. After compressors are energized the economizer stays at maximum open.

Y3 Demand:

Compressors 1 and 2 are energized while supply air blower stays on high cooling speed.

¹ Outdoor air suitability is determined by the energy state of outdoor ambient (enthalpy or sensible) and its ability to achieve the desired free cooling effects. Outdoor air suitability can also be determined by a third party controller and provided to the rooftop unit via a network connection.

Unit Does Not Feature An Economizer or Outdoor Air Is Not Suitable

Y1 Demand:

One compressor operates and the supply air blower operates at low cooling speed.

Y2 or Y3 Demand:

All compressors operate and supply air blower operates at high cooling speed.

SEQUENCE OF OPERATION

ZONE SENSOR MODE

When in zone sensor mode, the unit can modulate four stages of cooling or two stages of heating operation. In this case, the unit controller will control all unit staging operations. While in zone sensor mode, multi-stage air volume applications can use up to 4 different supply blower speed values for cooling. Zone sensor mode takes full advantage of the unit controller's features, increasing staging and control capabilities. To operate correctly, the unit must receive information from a temperature sensor. It may also receive setpoint information from a network device. Based on this information, the unit controller will either turn on or off various cooling and heating stages to maintain comfort control.

In zone sensor mode, it is possible to operate the unit without a network device. In this case the unit controller will control the zone temperature based on the backup occupied and unoccupied setpoints stored in the unit controller. The unit controller decides which setpoints to use based on the status of the occupied input. For example, if the unit is in occupied mode, the unit controller will use the occupied backup setpoints and if the unit is not in unoccupied mode the unit controller will use the unoccupied backup setpoints. In this scenario the unit controller not only records diagnostic information and makes sure the unit maintains safe operation limits,. It also controls all staging and unit operations.

ZONE SENSOR MODE HEATING

For heating, the unit controller monitors space temperature from the zone sensor. Based on this information and the setpoints sent to the unit controller from the Lennox or third-party network device, the unit controller turns on or off the heating stages to maintain the desired temperature setpoint.

The Ultra-High Efficiency product line features up to four independent heat stages in larger equipment. The exact percent of heating capacity used will vary depending on the size of the unit and the heating capacity. Regardless of how many stages are present, the unit controller will seek to provide the right amount of heat to satisfy the demand.

The sequence of operation for increasing and decreasing heating stages is best shown by the staging chart on page 19. As you can see from the chart, the unit will activate the heating stages if the space temperature drops to certain temperatures. If the temperature continues to drop, the unit will continue to add heating stages until the unit reaches full heating capacity. Notice that the example heating setpoint is 70°F with a 1° deadband. Also notice that the stage-up timer is 15 minutes. The unit controller will call for the next heating stage if the space temperature has been in the stage-up timer deadband region for 15 continuous minutes. The stage-up timer deadband region is the range between the temperature at which the current heating stage was called, and the temperature at which the next heating stage would be called. Heating stages will deactivate immediately after the space temperature has been satisfied. These are all default setpoints and can be changed to customize the unit to the specific application.

It is important to note that units with multi-stage air volume supply blowers operate at the selected heating speed for all stages of heating. The supply blower speed will not change as heat stages increase or decrease because there is only one heating supply blower speed setpoint.

ZONE SENSOR MODE COOLING

For cooling, the unit controller monitors space temperature from the zone sensor. Based on this information and the setpoints sent to the unit controller from an optional Lennox or third-party network device, the unit controller turns on or off cooling stages to maintain the desired temperature setpoint.

The Ultra-High Efficiency product line features up to four independent cooling stages in larger equipment. Regardless of how many stages are available, the unit controller will seek to provide the right amount of cooling to satisfy the demand. This helps provide great comfort control and to minimize energy consumption. The sequence of operation for increasing and decreasing cooling stages is best shown by the staging chart on page 19. As you can see from the chart, the unit will activate cooling stages if the space temperature rises above certain setpoints. If the temperature continues to rise, the unit will continue to add cooling stages until the unit reaches full cooling capacity. Notice that the example cooling setpoint is 75°F with a 1° deadband. Notice that the stage-up timer is 15 minutes. The unit controller will call for the next cooling stage if the space temperature has been in the stage-up timer deadband region for 15 continuous minutes. The stage-up timer deadband region is the range between the temperature at which the current cooling stage was called, and the temperature at which the next cooling stage would be called. Cooling mode has a stage-down delay default that keeps the next lower stage on for 15 minutes after a higher stage has ended. This feature is to make sure the unit doesn't prematurely shut off a cooling stage. These are all default setpoints and can be changed to customize the unit to the specific application.

SEQUENCE OF OPERATION

ZONE SENSOR MODE (continued)

ZONE SENSOR MODE COOLING WITH/WITHOUT ECONOMIZER

If the outdoor air is suitable and the unit features an economizer, instead of using mechanical cooling to meet the first cooling demand, the unit controller will try to meet the demand by opening the economizer and using outdoor air. The economizer damper will modulate to maintain 55°F supply air temperature) to meet the cooling demand.

If mechanical cooling is locked out because of low ambient outside air temperature, then mechanical cooling will not come on and the unit will attempt to satisfy any demand by modulating the economizer's damper position to maintain 55°F supply air temperature). The setpoints at which mechanical cooling locks out and the economizer maintains supply air temperature are adjustable.

If mechanical cooling is not locked out and if the unit is able to satisfy the room temperature requirements using outdoor air, then the unit will close the economizer to the minimum setpoint and cease cooling operation. If the unit is unable to satisfy the room temperature requirements using outdoor air, then the unit will react to a second cooling demand, which will trigger the first stage of mechanical cooling and bring the economizer to the full open position. The unit will continue turning on stages of mechanical cooling until the unit has satisfied the space temperature setpoint. Because the unit can provide up to 4 stages of cooling, and the economizer now qualifies as the first stage of cooling, the unit controller will group the remaining two compressors in a four compressor unit together in the event that two compressors are already energized. This means that to address the fourth stage cooling demand the unit will increase the mechanical cooling from two compressors energized to all compressors energized.

See table for unit operation without an economizer.

ZONE SENSOR MODE COOLING

Cooling Demand	Unit with Economizer	Unit Without Economizer or Outdoor Air is Unsuitable
One	Economizer	One Compressor
Two	Economizer + One Compressor	Two Compressors
Three	Economizer + Two Compressors	Three Compressors
Four	Economizer + All Compressors	All Compressors

SEQUENCE OF OPERATION

ZONE SENSOR MODE (continued)

ROOM SENSOR STAGES Default Values Shown

Units With Economizer:
 C1=Free Cooling
 C2=Compressor 1
 C3=Compressor 2
 C4=Compressor 3 + 4

C1=Cooling Stage 1
 C2=Cooling Stage 2
 C3=Cooling Stage 3
 C4=Cooling Stage 4

H1=Heating Stage 1
 H2=Heating Stage 2
 H3=Heating Stage 3
 H4=Heating Stage 4

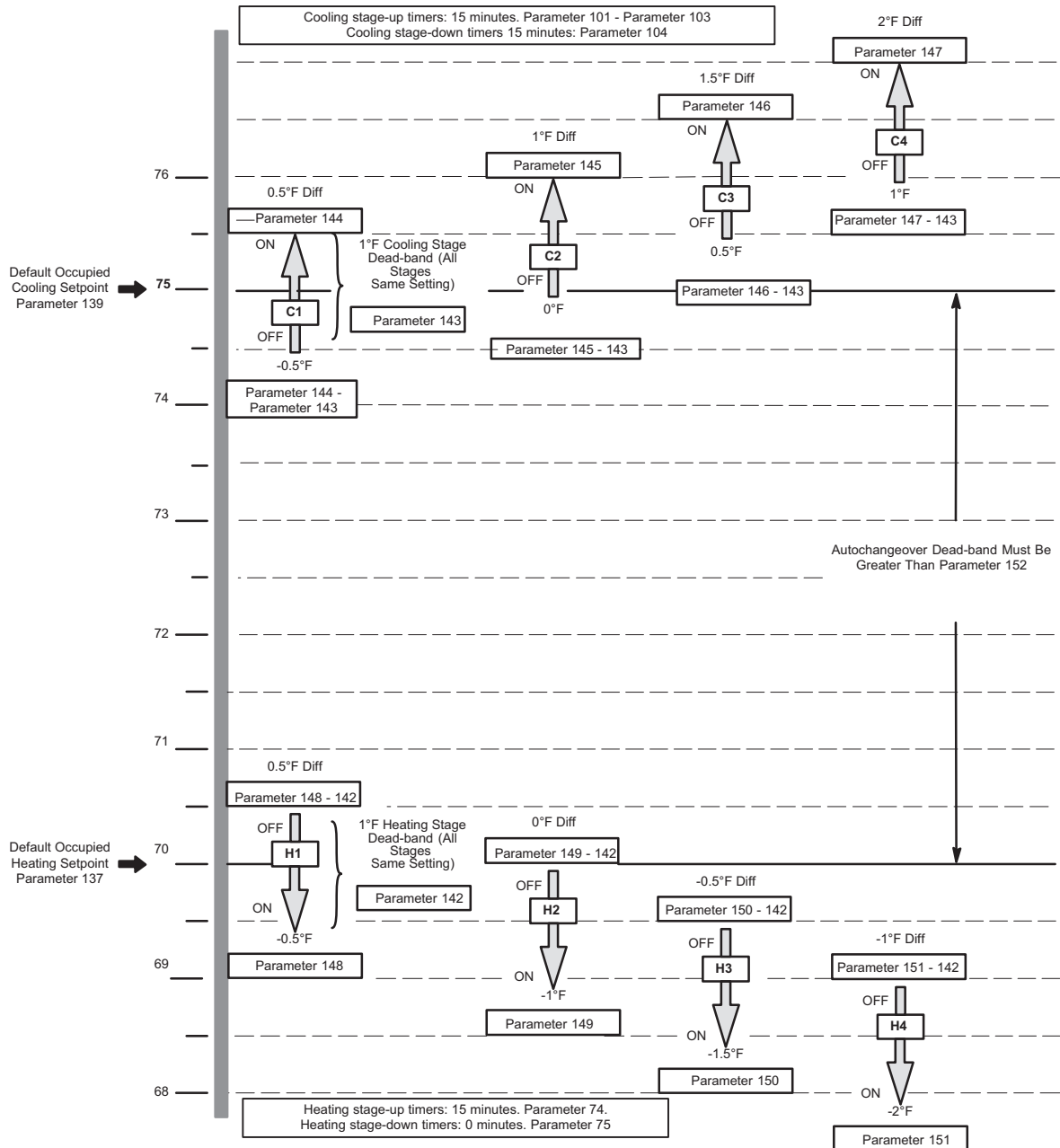

SEQUENCE OF OPERATION

ZONE SENSOR MODE - MSAV® (MULTI-STAGE AIR VOLUME)

Supply Air Blower CFM

Unit has following supply air blower speed setting:

- Ventilation speed
- Cooling Speed - Low
- Cooling Speed - High
- Heating speed
- Smoke speed (Used only in smoke removal option - not discussed)

¹ Unit Features An Economizer And Outdoor Air Is Suitable

Y1 Demand:

All compressors are off, supply air blower is on low cooling speed to minimize blower power consumption, economizer modulates (minimum to maximum open position) to maintain 55°F supply air temperature (default unit controller setting).

Y2 Demand:

All compressors are off, supply air blower is on high cooling speed providing higher cooling capacity, and economizer modulates to maintain 55°F supply air temperature.

If economizer stays at maximum open for 3 minutes, compressor 1 is energized while supply air blower stays on high cooling speed providing maximum cooling capacity. After compressors are energized the economizer stays at maximum open.

Y3 Demand:

Compressors 1 and 2 are energized and supply air blower stays on high cooling speed.

Unit Does Not Feature An Economizer Or Outdoor Air Is Not Suitable

Y1 Demand:

One compressor operates and supply air blower operates at low cooling speed.

Y2 Demand:

One compressor operates and supply air blower operates at medium cooling speed.

Y3 Demand:

All compressors operate and supply air blower operates at high cooling speed.

¹ Outdoor air suitability is determined by the energy state of outdoor ambient (enthalpy or sensible) and its ability to achieve the desired free cooling effects. Outdoor air suitability can also be determined by a third party controller and provided to the rooftop unit via a network connection.

OPTIONS / ACCESSORIES

Item Description	Catalog Number	Unit Model No			
		094	122	152	
COOLING SYSTEM					
Condensate Drain Trap	PVC	22H54	OX	OX	OX
	Copper	76W27	OX	OX	OX
Corrosion Protection	Factory		O	O	O
Drain Pan Overflow Switch	21Z07		OX	OX	OX
Refrigerant Type	R-410A		O	O	O
BLOWER - SUPPLY AIR					
Blower	DirectPlus™ (Direct Drive) MSAV (Multi-Stage Air Volume) supply air blower	Factory	O	O	O
	Belt Drive MSAV (Multi-Stage Air Volume) supply air blower (With VFD Bypass Control)	Factory	O	O	O
	Belt Drive MSAV (Multi-Stage Air Volume) supply air blower (Without VFD Bypass Control)	Factory	O	O	O
Motors - MSAV® Multi-Stage Air Volume supply air	DirectPlus™ (direct drive) ECM 3.75 hp	Factory	O	O	O
	Belt Drive (standard efficiency) - 2 hp	Factory	O	O	O
	Belt Drive (standard efficiency) - 3 hp	Factory	O	O	O
	Belt Drive (standard efficiency) - 5 hp	Factory	O	O	O
Drive Kits See Blower Data Tables for selection	Kit #1 590-890 rpm	Factory	O	O	O
	Kit #2 800-1105 rpm	Factory	O	O	O
	Kit #3 795-1195 rpm	Factory	O	O	O
	Kit #4 730-970 rpm	Factory	O	O	O
	Kit #5 940-1200 rpm	Factory	O	O	O
	Kit #6 1015-1300 rpm	Factory	O	O	O
	Kit #7 730-970 rpm	Factory	O	O	O
	Kit #8 940-1200 rpm	Factory	O	O	O
	Kit #9 1015-1300 rpm	Factory	O	O	O
	Kit #10 900-1135 rpm	Factory	O	O	O
	Kit #11 1040-1315 rpm	Factory	O	O	O
	Kit #12 1125-1425 rpm	Factory	O	O	O
	Blower Belt Auto-Tensioner	Factory	O	O	O
CABINET					
Combination Coil/Hail Guards	13T06		X	X	X
Horizontal Discharge Kit	51W25		X	X	X
Return Air Adaptor Plate (for LC/LG and TC/TG/TH unit replacement)	54W96		OX	OX	OX

NOTE - Catalog numbers shown are for ordering field installed accessories.

OX = Configure To Order (Factory Installed) or Field Installed.

O = Configure To Order (Factory Installed).

X = Field Installed

OPTIONS / ACCESSORIES

Item Description	Catalog Number	Unit Model No			
		094	122	152	
CONTROLS					
Blower Proving Switch	21Z10	OX	OX	OX	
Commercial Controls	Prodigy® Control System - BACnet® Module	59W51	OX	OX	OX
	Prodigy® Control System - LonTalk® Module	54W27	OX	OX	OX
	Novar® LSM	Factory	O	O	O
	L Connection® Building Automation System	Factory	X	X	X
Dirty Filter Switch	53W67	OX	OX	OX	
Fresh Air Tempering	21Z08	OX	OX	OX	
General Purpose Control Kit	13J78	X	X	X	
Smoke Detector - Supply or Return (Power board and one sensor)	11K76	OX	OX	OX	
Smoke Detector - Supply and Return (Power board and two sensors)	11K80	OX	OX	OX	
INDOOR AIR QUALITY					
Air Filters					
Healthy Climate® High Efficiency Air Filters 20 x 25 x 2 (Order 4 per unit)	MERV 8	50W61	OX	OX	OX
	MERV 13	52W41	OX	OX	OX
Replacement Media Filter With Metal Mesh Frame (includes non-pleated filter media)		Y3063	X	X	X
Indoor Air Quality (CO₂) Sensors					
Sensor - Wall-mount, off-white plastic cover with LCD display		77N39	X	X	X
Sensor - Wall-mount, off-white plastic cover, no display		87N53	X	X	X
Sensor - Black plastic case with LCD display, rated for plenum mounting		87N52	X	X	X
Sensor - Wall-mount, black plastic case, no display, rated for plenum mounting		87N54	X	X	X
CO ₂ Sensor Duct Mounting Kit - for downflow applications		85L43	X	X	X
Aspiration Box - for duct mounting non-plenum rated CO ₂ sensors (87N53 or 77N39)		90N43	X	X	X
UVC Germicidal Lamps					
¹ Healthy Climate® UVC Light Kit (110/230v-1ph)		21A93	X	X	X
Step-Down Transformers	460V primary, 230V secondary	10H20	X	X	X
	575V primary, 230V secondary	10H21	X	X	X
ELECTRICAL					
Voltage 60 hz	208/230V - 3 phase	Factory	O	O	O
	460V - 3 phase	Factory	O	O	O
	575V - 3 phase	Factory	O	O	O
HACR Circuit Breakers		Factory	O	O	O
Disconnect Switch - See Electrical/Electric Heat tables for selection	80 amp	54W56	OX	OX	OX
	150 amp	54W57	OX	OX	OX
² Short-Circuit Current Rating (SCCR) of 100kA (includes Phase/Voltage Detection)		Factory	O	O	O
GFI Service Outlets	15 amp non-powered, field-wired (208/230V, 460V only)	74M70	OX	OX	OX
	20 amp non-powered, field-wired (575V only)	67E01	OX	OX	OX
Weatherproof Cover for GFI		10C89	X	X	X

¹ Lamps operate on 110-230V single-phase power supply. Step-down transformer may be ordered separately for 460V and 575V units. Alternately, 110V power supply may be used to directly power the UVC ballast(s).

² Disconnect Switch not available with higher SCCR option. Short-Circuit Current Rating option not available on field installed electric heat.

NOTE - Catalog numbers shown are for ordering field installed accessories.

OX = Configure To Order (Factory Installed) or Field Installed.

O = Configure To Order (Factory Installed).

X = Field Installed

OPTIONS / ACCESSORIES

Item Description	Catalog Number	Unit Model No			
		094	122	152	
ELECTRIC HEAT - DIRECT DRIVE UNITS					
7.5 kW	208/230V-3ph	10U96	OX		
	460V-3ph	10U97	OX		
	575V-3ph	11J19	OX		
15 kW	208/230V-3ph	10U99	OX	OX	OX
	460V-3ph	10X01	OX	OX	OX
	575V-3ph	10X02	OX	OX	OX
22.5 kW	208/230V-3ph	10X03	OX	OX	OX
	460V-3ph	10X04	OX	OX	OX
	575V-3ph	10X05	OX	OX	OX
30 kW	208/230V-3ph	10X06	OX	OX	OX
	460V-3ph	10X07	OX	OX	OX
	575V-3ph	10X08	OX	OX	OX
45 kW	208/230V-3ph	10X09	OX	OX	OX
	460V-3ph	10X11	OX	OX	OX
	575V-3ph	10X12	OX	OX	OX
60 kW	208/230V-3ph	10X13		OX	OX
	460V-3ph	10X14		OX	OX
	575V-3ph	10X15		OX	OX
ELECTRIC HEAT - BELT DRIVE UNITS					
7.5 kW	208/230V-3ph	56W38	OX		
	460V-3ph	56W39	OX		
	575V-3ph	56W40	OX		
15 kW	208/230V-3ph	56W41	OX	OX	OX
	460V-3ph	56W42	OX	OX	OX
	575V-3ph	56W43	OX	OX	OX
22.5 kW	208/230V-3ph	56W44	OX	OX	OX
	460V-3ph	56W45	OX	OX	OX
	575V-3ph	56W46	OX	OX	OX
30 kW	208/230V-3ph	56W47	OX	OX	OX
	460V-3ph	56W48	OX	OX	OX
	575V-3ph	56W49	OX	OX	OX
45 kW	208/230V-3ph	56W50	OX	OX	OX
	460V-3ph	56W51	OX	OX	OX
	575V-3ph	56W52	OX	OX	OX
60 kW	208/230V-3ph	55W02		OX	OX
	460V-3ph	55W03		OX	OX
	575V-3ph	55W04		OX	OX
¹ SCR (Silicon Controlled Rectifier) Electric Heat Control		Factory	O	O	O
Thermostat (required)		45N59	X	X	X
Duct Sensor (required)		45N60	X	X	X

¹ The SCR option is not available with 45 kW and 60 kW electric heat (208/230V) models.

NOTE - Catalog numbers shown are for ordering field installed accessories.

OX = Configure To Order (Factory Installed) or Field Installed.

O = Configure To Order (Factory Installed).

X = Field Installed

OPTIONS / ACCESSORIES

Item Description	Catalog Number	Unit Model No			
		094	122	152	
ECONOMIZER					
High Performance Economizer (Approved for California Title 24 Building Standards / AMCA Class 1A Certified)					
High Performance Economizer Downflow or Horizontal - Includes Outdoor Air Hood and Downflow Barometric Relief Dampers with Exhaust Hood Order Horizontal Barometric Relief Dampers separately	20U80	OX	OX	OX	
Economizer Controls					
Differential Enthalpy (Not for Title 24)	Order 2 21Z09	OX	OX	OX	
Sensible Control	Sensor is Furnished Factory	O	O	O	
Single Enthalpy (Not for Title 24)	21Z09	OX	OX	OX	
Global Control	Sensor Field Provided Factory	O	O	O	
Building Pressure Control	13J77	X	X	X	
Outdoor Air CFM Control	13J76	X	X	X	
Horizontal Barometric Relief Dampers					
Horizontal Low Profile Barometric Relief Dampers With Exhaust Hood	53K04	X	X	X	
OUTDOOR AIR					
Outdoor Air Dampers					
Motorized Dampers (Hood furnished)	14G28	OX	OX	OX	
Manual Dampers (Hood furnished)	14G29	OX	OX	OX	
POWER EXHAUST					
Standard Static	208/230V-3ph	53W44	OX	OX	OX
	460V-3ph	53W45	OX	OX	OX
	575V-3ph	53W46	OX	OX	OX

NOTE - Catalog numbers shown are for ordering field installed accessories.
 OX = Configure To Order (Factory Installed) or Field Installed.
 O = Configure To Order (Factory Installed).
 X = Field Installed

OPTIONS / ACCESSORIES

Item Description	Catalog Number	Unit Model No		
		094	122	152
ROOF CURBS				
Hybrid Roof Curbs, Downflow				
8 in. height	11F54	X	X	X
14 in. height	11F55	X	X	X
18 in. height	11F56	X	X	X
24 in. height	11F57	X	X	X
Adjustable Pitch Curb				
14 in. height	54W50	X	X	X
CEILING DIFFUSERS				
Step-Down - Order one	RTD11-95S	13K61	X	
	RTD11-135S	13K62		X
	RTD11-185S	13K63		X
Flush - Order one	FD11-95S	13K56	X	
	FD11-135S	13K57		X
	FD11-185S	13K58		X
Transitions (Supply and Return) - Order one	C1DIFF30B-1	12X65	X	
	C1DIFF31B-1	12X66		X
	C1DIFF32B-1	12X67		X

NOTE - Catalog numbers shown are for ordering field installed accessories.
 OX = Configure To Order (Factory Installed) or Field Installed.
 O = Configure To Order (Factory Installed).
 X = Field Installed

SPECIFICATIONS		DIRECT DRIVE		
General Data		7.5 Ton	10 Ton	12.5 Ton
	Nominal Tonnage			
	Model Number	LCH094U4E	LCH122U4E	LCH152U4E
	Efficiency Type	Ultra-High	Ultra-High	Ultra-High
	Blower Type	DirectPlus™ ECM Direct Drive	DirectPlus™ ECM Direct Drive	DirectPlus™ ECM Direct Drive
Cooling Performance	Gross Cooling Capacity - Btuh	93,700	119,000	141,900
	¹ Net Cooling Capacity - Btuh	92,000	116,000	138,000
	AHRI Rated Air Flow - cfm	2800	3600	4000
	Total Unit Power - kW	6.6	8.8	11.2
	¹ EER (Btuh/Watt)	13.9	13.1	12.3
	² IEER (Btuh/Watt)	21.5	20.0	18.9
Refrigerant Charge	Refrigerant Type	R-410A	R-410A	R-410A
	Circuit 1	29 lbs. 0 oz.	29 lbs. 0 oz.	29 lbs. 0 oz.
Electric Heat Available - See page 23		7.5, 15, 22.5, 30, 45 kW	15, 22.5, 30, 45, 60 kW	
Compressor Type (number)		Tandem Scroll (2)	Tandem Scroll (2)	Tandem Scroll (2)
Outdoor Coils	Net face area (total) - sq. ft.	40.8	40.8	40.8
	Number of rows	2	2	2
	Fins per inch	20	20	20
Outdoor Coil Fans	Motor - (No.) hp	(3) 1/3 ECM	(3) 1/3 ECM	(3) 1/3 ECM
	Motor rpm	520 - 900	640 - 900	640 - 900
	Total Motor watts	160 - 650	280 - 650	280 - 650
	Diameter - (No.) in.	(3) 24	(3) 24	(3) 24
	Number of blades	3	3	3
	Total Air volume - cfm	5160 - 10,250	7100 - 10,250	7100 - 10,250
Indoor Coil	Net face area (total) - sq. ft.	13.54	13.54	13.54
	Tube diameter - in.	3/8	3/8	3/8
	Number of rows	4	4	4
	Fins per inch	14	14	14
	Drain connection - Number and size	(1) 1 in. NPT coupling		
	Expansion device type	Dual-Flow Thermal Expansion Valve System with Flow Control Balance port, removable head		
Indoor Blower	Nominal motor output	3.75 HP (ECM)	3.75 HP (ECM)	3.75 HP (ECM)
	Blower wheel nominal diameter x width - in.	(1) 22 x 9	(1) 22 x 9	(1) 22 x 9
Filters	Type of filter	Disposable		
	Number and size - in.	(4) 20 x 25 x 2		
Electrical characteristics		208/230V or 460V - 60 hertz - 3 phase		

NOTE - Net capacity includes evaporator blower motor heat deduction. Gross capacity does not include evaporator blower motor heat deduction.

¹ AHRI Certified to AHRI Standard 340/360; 95°F outdoor air temperature and 80°F db/67°F wb entering evaporator air; minimum external duct static pressure.

² Integrated Energy Efficiency Ratio certified and tested according to AHRI Standard 340/360.

SPECIFICATIONS		BELT DRIVE		
General Data		7.5 Ton	10 Ton	12.5 Ton
	Nominal Tonnage			
	Model Number	LCH094U4M	LCH122U4M	LCH152U4M
	Efficiency Type	Ultra-High	Ultra-High	Ultra-High
	Blower Type	MSAV® (Multi-Stage Air Volume) Belt Drive	MSAV® (Multi-Stage Air Volume) Belt Drive	MSAV® (Multi-Stage Air Volume) Belt Drive
Cooling Performance	Gross Cooling Capacity - Btuh	93,700	119,000	141,900
	¹ Net Cooling Capacity - Btuh	92,000	116,000	136,000
	AHRI Rated Air Flow - cfm	2800	3600	4000
	Total Unit Power - kW	6.9	8.8	11.3
	¹ EER (Btuh/Watt)	13.4	12.6	12.0
	² IEER (Btuh/Watt)	20.7	19.2	18.1
Refrigerant Charge	Refrigerant Type	R-410A	R-410A	R-410A
	Circuit 1	29 lbs. 0 oz.	29 lbs. 0 oz.	29 lbs. 0 oz.
Electric Heat Available - See page 23		7.5, 15, 22.5, 30, 45 kW	15, 22.5, 30, 45, 60 kW	
Compressor Type (number)		Tandem Scroll (2)	Tandem Scroll (2)	Tandem Scroll (2)
Outdoor Coils	Net face area (total) - sq. ft.	40.8	40.8	40.8
	Number of rows	2	2	2
	Fins per inch	20	20	20
Outdoor Coil Fans	Motor - (No.) hp	(3) 1/3 ECM	(3) 1/3 ECM	(3) 1/3 ECM
	Motor rpm	520 - 900	640 - 900	640 - 900
	Total Motor watts	160 - 650	280 - 650	280 - 650
	Diameter - (No.) in.	(3) 24	(3) 24	(3) 24
	Number of blades	3	3	3
	Total Air volume - cfm	5160 - 10,250	7100 - 10,250	7100 - 10,250
Indoor Coil	Net face area (total) - sq. ft.	13.54	13.54	13.54
	Tube diameter - in.	3/8	3/8	3/8
	Number of rows	4	4	4
	Fins per inch	14	14	14
	Drain connection - Number and size	(1) 1 in. NPT coupling		
Expansion device type		Dual-Flow Thermal Expansion Valve System with Flow Control Balance port, removable head		
³ Indoor Blower and Drive Selection	Nominal motor output	2 hp, 3 hp, 5 hp		
	Motor - Drive kit number	2 hp Kit 1 590-890 rpm (std. and high efficiency) Kit 2 800-1105 rpm (std. and high efficiency) Kit 3 795-1195 rpm (std. and high efficiency) 3 hp Kit 4 730-970 rpm (std. efficiency) Kit 5 940-1200 rpm (std. efficiency) Kit 6 1015-1300 rpm (std. efficiency) Kit 7 730-970 rpm (high efficiency) Kit 8 940-1200 rpm (high efficiency) Kit 9 1015-1300 rpm (high efficiency) 5 hp Kit 10 900-1135 rpm (std. efficiency) Kit 11 1040-1315 rpm (std. efficiency) Kit 12 1125-1425 rpm (std. efficiency)		
Blower wheel nominal diameter x width - in.		(1) 15 X 15	(1) 15 X 15	(1) 15 X 15
Filters	Type of filter	Disposable		
	Number and size - in.	(4) 20 x 25 x 2		
Electrical characteristics		208/230V, 460V or 575V - 60 hertz - 3 phase		

NOTE - Net capacity includes evaporator blower motor heat deduction. Gross capacity does not include evaporator blower motor heat deduction.

¹ AHRI Certified to AHRI Standard 340/360; 95°F outdoor air temperature and 80°F db/67°F wb entering evaporator air; minimum external duct static pressure.

² Integrated Energy Efficiency Ratio certified and tested according to AHRI Standard 340/360.

³ Using total air volume and system static pressure requirements determine from blower performance tables rpm and motor output required. Maximum usable output of motors furnished are shown. In Canada, nominal motor output is also maximum usable motor output. If motors of comparable output are used, be sure to keep within the service factor limitations outlined on the motor nameplate.

RATINGS

NOTE – For Temperatures and Capacities not shown in tables, see bulletin – Cooling Unit Rating Table Correction Factor Data in Miscellaneous Engineering Data section.

7.5 TON LCH094U4E AND LCH094U4M (1ST STAGE)

Entering Wet Bulb Temperature	Total Air Volume	Outdoor Air Temperature Entering Outdoor Coil																			
		65°F					75°F					85°F					95°F				
		Total Cool Cap.	Comp. Motor Input	Sensible To Total Ratio (S/T)			Total Cool Cap.	Comp. Motor Input	Sensible To Total Ratio (S/T)			Total Cool Cap.	Comp. Motor Input	Sensible To Total Ratio (S/T)			Total Cool Cap.	Comp. Motor Input	Sensible To Total Ratio (S/T)		
				Dry Bulb					Dry Bulb					Dry Bulb					Dry Bulb		
cfm	kBtuh	kW	75°F	80°F	85°F	kBtuh	kW	75°F	80°F	85°F	kBtuh	kW	75°F	80°F	85°F	kBtuh	kW	75°F	80°F	85°F	
63°F	1680	56.2	1.85	0.69	0.87	1	52.2	2.11	0.7	0.9	1	47.9	2.39	0.7	0.93	1	43.5	2.71	0.71	0.96	1
	2100	59.6	1.85	0.75	0.99	1	55.8	2.11	0.76	1	1	51.8	2.39	0.78	1	1	47.6	2.7	0.81	1	1
	2520	63.5	1.85	0.83	1	1	59.4	2.11	0.86	1	1	55.2	2.39	0.9	1	1	50.8	2.7	0.94	1	1
67°F	1680	60.5	1.85	0.54	0.68	0.82	56.2	2.11	0.54	0.68	0.85	51.8	2.39	0.52	0.69	0.88	47.4	2.7	0.52	0.69	0.9
	2100	63.9	1.85	0.57	0.73	0.93	59.3	2.11	0.57	0.74	0.99	54.7	2.39	0.57	0.76	1	49.8	2.7	0.58	0.78	1
	2520	66.2	1.85	0.61	0.8	1	61.5	2.11	0.62	0.83	1	56.6	2.39	0.63	0.86	1	51.7	2.7	0.63	0.92	1
71°F	1680	65.1	1.85	0.4	0.53	0.66	60.7	2.11	0.39	0.53	0.66	56	2.39	0.37	0.52	0.67	51.3	2.7	0.34	0.52	0.67
	2100	68.5	1.85	0.39	0.57	0.71	63.7	2.11	0.42	0.57	0.73	58.9	2.39	0.39	0.57	0.74	53.6	2.7	0.4	0.58	0.76
	2520	70.7	1.85	0.42	0.61	0.77	65.7	2.11	0.43	0.62	0.8	60.7	2.38	0.43	0.62	0.83	55.6	2.69	0.42	0.63	0.88

7.5 TON LCH094U4E AND LCH094U4M (2ND STAGE)

Entering Wet Bulb Temperature	Total Air Volume	Outdoor Air Temperature Entering Outdoor Coil																			
		85°F					95°F					105°F					115°F				
		Total Cool Cap.	Comp. Motor Input	Sensible To Total Ratio (S/T)			Total Cool Cap.	Comp. Motor Input	Sensible To Total Ratio (S/T)			Total Cool Cap.	Comp. Motor Input	Sensible To Total Ratio (S/T)			Total Cool Cap.	Comp. Motor Input	Sensible To Total Ratio (S/T)		
				Dry Bulb					Dry Bulb					Dry Bulb					Dry Bulb		
cfm	kBtuh	kW	75°F	80°F	85°F	kBtuh	kW	75°F	80°F	85°F	kBtuh	kW	75°F	80°F	85°F	kBtuh	kW	75°F	80°F	85°F	
63°F	2400	89.7	4.87	0.62	0.78	0.97	83.6	5.51	0.62	0.8	1	77.3	6.25	0.63	0.82	1	70.5	7.12	0.65	0.87	1
	3000	95.4	4.88	0.67	0.89	1	88.9	5.51	0.69	0.92	1	82.1	6.25	0.71	0.97	1	75	7.11	0.73	1	1
	3600	99.8	4.88	0.74	0.98	1	93.3	5.52	0.76	1	1	87	6.25	0.79	1	1	80.3	7.1	0.82	1	1
67°F	2400	96.5	4.88	0.48	0.6	0.74	90.2	5.52	0.48	0.6	0.76	83.3	6.25	0.48	0.62	0.78	76.2	7.11	0.48	0.63	0.82
	3000	102	4.88	0.52	0.65	0.83	95.1	5.51	0.52	0.66	0.87	88	6.25	0.52	0.68	0.91	80.1	7.1	0.52	0.7	0.96
	3600	105.9	4.89	0.55	0.72	0.94	98.5	5.52	0.55	0.74	0.98	91.4	6.24	0.56	0.76	1	83.5	7.1	0.57	0.8	1
71°F	2400	103.2	4.88	0.36	0.47	0.58	96.7	5.52	0.35	0.47	0.58	89.5	6.25	0.34	0.47	0.6	82	7.1	0.33	0.47	0.61
	3000	108.9	4.89	0.38	0.51	0.63	101.8	5.52	0.37	0.51	0.64	94.1	6.24	0.36	0.51	0.66	86.1	7.09	0.35	0.52	0.68
	3600	113	4.89	0.39	0.54	0.69	105.4	5.52	0.38	0.54	0.71	97.6	6.24	0.38	0.55	0.73	89.3	7.09	0.37	0.56	0.78

10 TON LCH122U4E AND LCH122U4M (1ST STAGE)

Entering Wet Bulb Temperature	Total Air Volume	Outdoor Air Temperature Entering Outdoor Coil																			
		65°F					75°F					85°F					95°F				
		Total Cool Cap.	Comp. Motor Input	Sensible To Total Ratio (S/T)			Total Cool Cap.	Comp. Motor Input	Sensible To Total Ratio (S/T)			Total Cool Cap.	Comp. Motor Input	Sensible To Total Ratio (S/T)			Total Cool Cap.	Comp. Motor Input	Sensible To Total Ratio (S/T)		
				Dry Bulb					Dry Bulb					Dry Bulb					Dry Bulb		
cfm	kBtuh	kW	75°F	80°F	85°F	kBtuh	kW	75°F	80°F	85°F	kBtuh	kW	75°F	80°F	85°F	kBtuh	kW	75°F	80°F	85°F	
63°F	2240	72	2.44	0.67	0.86	1	67.7	2.82	0.68	0.9	1	63.2	3.21	0.68	0.94	1	58.4	3.65	0.68	0.98	1
	2800	75.9	2.46	0.73	1	1	72	2.84	0.74	1	1	67.7	3.24	0.76	1	1	63.3	3.68	0.8	1	1
	3360	80.4	2.48	0.81	1	1	76.1	2.86	0.85	1	1	71.5	3.26	0.9	1	1	66.8	3.7	0.95	1	1
67°F	2240	76.7	2.46	0.53	0.65	0.8	72.1	2.84	0.53	0.66	0.83	67.4	3.23	0.52	0.67	0.88	62.4	3.67	0.52	0.68	0.92
	2800	80.6	2.48	0.56	0.71	0.96	75.6	2.85	0.56	0.72	0.99	70.7	3.25	0.56	0.74	1	65.4	3.69	0.56	0.76	1
	3360	83.1	2.49	0.59	0.78	1	78.2	2.87	0.6	0.81	1	72.9	3.27	0.62	0.86	1	67.6	3.71	0.62	0.92	1
71°F	2240	82.1	2.48	0.39	0.52	0.63	77.5	2.86	0.39	0.52	0.64	72.4	3.26	0.38	0.52	0.66	67.2	3.7	0.35	0.52	0.67
	2800	85.8	2.5	0.41	0.55	0.69	80.7	2.88	0.4	0.56	0.71	75.5	3.28	0.4	0.56	0.72	70	3.72	0.38	0.56	0.74
	3360	88.4	2.51	0.42	0.59	0.75	83.1	2.89	0.42	0.6	0.78	77.5	3.29	0.42	0.61	0.82	71.9	3.73	0.42	0.62	0.88

10 TON LCH122U4E AND LCH122U4M (2ND STAGE)

Entering Wet Bulb Temperature	Total Air Volume	Outdoor Air Temperature Entering Outdoor Coil																			
		85°F					95°F					105°F					115°F				
		Total Cool Cap.	Comp. Motor Input	Sensible To Total Ratio (S/T)			Total Cool Cap.	Comp. Motor Input	Sensible To Total Ratio (S/T)			Total Cool Cap.	Comp. Motor Input	Sensible To Total Ratio (S/T)			Total Cool Cap.	Comp. Motor Input	Sensible To Total Ratio (S/T)		
				Dry Bulb					Dry Bulb					Dry Bulb					Dry Bulb		
cfm	kBtuh	kW	75°F	80°F	85°F	kBtuh	kW	75°F	80°F	85°F	kBtuh	kW	75°F	80°F	85°F	kBtuh	kW	75°F	80°F	85°F	
63°F	3200	115.6	6.41	0.65	0.81	0.99	108.7	7.28	0.66	0.84	1	101.6	8.26	0.67	0.86	1	93.7	9.39	0.68	0.91	1
	4000	121.9	6.46	0.7	0.91	1	114.5	7.32	0.72	0.95	1	107	8.31	0.74	0.98	1	99.1	9.43	0.77	1	1
	4800	126.7	6.5	0.77	1	1	119.8	7.37	0.8	1	1	112.3	8.35	0.82	1	1	104.9	9.48	0.87	1	1
67°F	3200	123.2	6.47	0.51	0.63	0.77	115.9	7.33	0.51	0.64	0.79	108.3	8.31	0.51	0.65	0.82	100.2	9.45	0.52	0.67	0.86
	4000	129.3	6.52	0.54	0.68	0.86	121.4	7.38	0.55	0.69	0.9	113.7	8.35	0.55	0.72	0.94	105	9.48	0.56	0.75	0.99
	4800	133.9	6.56	0.57	0.75	0.97	125.8	7.42	0.58	0.77	0.99	117.2	8.39	0.59	0.8	1	108.2	9.51	0.6	0.84	1
71°F	3200	131	6.53	0.38	0.49	0.61	123.6	7.4	0.38	0.5	0.62	115.4	8.37	0.37	0.5	0.63	106.7	9.49	0.37	0.51	0.65
	4000	136.8	6.58	0.4	0.53	0.66	128.9	7.44	0.39	0.54	0.67	120.4	8.42	0.39	0.54	0.69	111.7	9.54	0.39	0.55	0.72
	4800	141.6	6.63	0.41	0.57	0.72	133.3	7.49	0.41	0.57	0.74	124.4	8.46	0.41	0.58	0.77	115	9.57	0.4	0.59	0.81

RATINGS

NOTE – For Temperatures and Capacities not shown in tables, see bulletin – Cooling Unit Rating Table Correction Factor Data in Miscellaneous Engineering Data section.

12.5 TON LCH152U4E AND LCH152U4M (1ST STAGE)

Entering Wet Bulb Temperature	Total Air Volume	Outdoor Air Temperature Entering Outdoor Coil																			
		65°F					75°F					85°F					95°F				
		Total Cool Cap.	Comp. Motor Input	Sensible To Total Ratio (S/T)			Total Cool Cap.	Comp. Motor Input	Sensible To Total Ratio (S/T)			Total Cool Cap.	Comp. Motor Input	Sensible To Total Ratio (S/T)			Total Cool Cap.	Comp. Motor Input	Sensible To Total Ratio (S/T)		
				Dry Bulb					Dry Bulb					Dry Bulb					Dry Bulb		
		cfm	kBtuh	kW	75°F	80°F	85°F	kBtuh	kW	75°F	80°F	85°F	kBtuh	kW	75°F	80°F	85°F	kBtuh	kW	75°F	80°F
63°F	2560	83.9	3.05	0.68	0.85	1	78.6	3.47	0.69	0.88	1	73.2	3.93	0.7	0.92	1	67.5	4.44	0.71	0.96	1
	3200	88.5	3.07	0.74	0.98	1	83.2	3.5	0.75	1	1	78.2	3.96	0.77	1	1	72.8	4.47	0.79	1	1
	3840	93.5	3.09	0.81	1	1	88.4	3.53	0.83	1	1	82.9	3.99	0.88	1	1	76.9	4.5	0.92	1	1
67°F	2560	89.7	3.07	0.53	0.66	0.8	84.1	3.5	0.53	0.67	0.81	78.4	3.96	0.53	0.68	0.86	72.4	4.47	0.53	0.69	0.9
	3200	94	3.1	0.57	0.72	0.94	88.2	3.53	0.57	0.73	0.97	82.1	3.99	0.57	0.75	1	75.8	4.49	0.58	0.77	1
	3840	97.4	3.11	0.6	0.78	1	91.2	3.54	0.6	0.81	1	85	4	0.61	0.84	1	78.6	4.51	0.63	0.89	1
71°F	2560	95.9	3.1	0.4	0.52	0.64	90.1	3.54	0.39	0.53	0.65	84.1	4	0.38	0.53	0.66	78	4.51	0.37	0.53	0.67
	3200	100.4	3.13	0.42	0.56	0.7	94.3	3.56	0.41	0.57	0.72	88	4.03	0.4	0.56	0.73	81.4	4.53	0.4	0.57	0.75
	3840	103.6	3.15	0.43	0.6	0.76	97.3	3.58	0.43	0.6	0.78	90.8	4.04	0.42	0.61	0.81	83.8	4.55	0.42	0.62	0.86

12.5 TON LCH152U4E AND LCH152U4M (2ND STAGE)

Entering Wet Bulb Temperature	Total Air Volume	Outdoor Air Temperature Entering Outdoor Coil																			
		85°F					95°F					105°F					115°F				
		Total Cool Cap.	Comp. Motor Input	Sensible To Total Ratio (S/T)			Total Cool Cap.	Comp. Motor Input	Sensible To Total Ratio (S/T)			Total Cool Cap.	Comp. Motor Input	Sensible To Total Ratio (S/T)			Total Cool Cap.	Comp. Motor Input	Sensible To Total Ratio (S/T)		
				Dry Bulb					Dry Bulb					Dry Bulb					Dry Bulb		
		cfm	kBtuh	kW	75°F	80°F	85°F	kBtuh	kW	75°F	80°F	85°F	kBtuh	kW	75°F	80°F	85°F	kBtuh	kW	75°F	80°F
63°F	3800	139.9	8.27	0.67	0.83	0.99	131.4	9.34	0.68	0.85	1	122.4	10.57	0.69	0.88	1	112.8	11.98	0.71	0.91	1
	4400	144.9	8.33	0.71	0.89	1	136.3	9.39	0.72	0.91	1	126.9	10.61	0.74	0.95	1	117.3	12.03	0.76	0.98	1
	5000	149.3	8.36	0.74	0.94	1	140	9.42	0.76	0.97	1	130.8	10.64	0.78	1	1	121.3	12.05	0.81	1	1
67°F	3800	149.1	8.35	0.53	0.65	0.79	140.3	9.42	0.53	0.66	0.81	130.9	10.65	0.53	0.67	0.84	120.9	12.05	0.53	0.69	0.87
	4400	154.1	8.41	0.55	0.68	0.85	145.2	9.47	0.55	0.69	0.87	135.3	10.69	0.55	0.71	0.9	125	12.09	0.56	0.74	0.95
	5000	158.3	8.45	0.57	0.72	0.9	148.8	9.51	0.57	0.74	0.94	138.8	10.72	0.58	0.76	0.97	128	12.12	0.59	0.79	1
71°F	3800	158.6	8.45	0.39	0.51	0.63	149.3	9.51	0.39	0.52	0.64	139.1	10.71	0.38	0.52	0.65	128.7	12.13	0.38	0.52	0.67
	4400	163.5	8.5	0.4	0.54	0.66	153.8	9.56	0.4	0.54	0.67	143.7	10.77	0.4	0.54	0.69	133	12.18	0.39	0.55	0.71
	5000	167.6	8.54	0.41	0.56	0.7	157.7	9.6	0.41	0.56	0.71	147.7	10.82	0.41	0.57	0.74	136.3	12.2	0.4	0.58	0.76

BLOWER DATA

DIRECT DRIVE | ALL MODELS

BLOWER TABLE INCLUDES RESISTANCE FOR BASE UNIT ONLY (NO HEAT SECTION) WITH DRY INDOOR COIL AND AIR FILTERS IN PLACE.

FOR ALL UNITS ADD:

- 1 - Wet indoor coil air resistance of selected unit.
 - 2 - Any factory installed options air resistance (heat section, economizer, etc.)
 - 3 - Any field installed accessories air resistance (duct resistance, diffuser, etc.)
- See page 33 for wet coil and option/accessory air resistance data.

MINIMUM AIR VOLUME REQUIRED FOR USE WITH OPTIONAL ELECTRIC HEAT (Maximum Static Pressure - 2.0 in. w.g.)

094 Models - 7.5 kW - 1750 cfm

All Models - 15 kW, 22.5 kW, 30 kW, 45 kW - 2750 cfm

122 and 152 Models - 60 kW - 3500 cfm

Total Air Volume cfm	Total Static Pressure - in. w.g.													
	0.2		0.4		0.6		0.8		1.0		1.2		1.4	
	RPM	Watts	RPM	Watts	RPM	Watts	RPM	Watts	RPM	Watts	RPM	Watts	RPM	Watts
1750	711	188	771	279	836	366	905	453	975	544	1044	640	1109	737
2000	752	242	812	332	876	420	944	510	1011	606	1075	709	1138	812
2250	799	300	860	389	923	479	988	575	1052	678	1113	787	1171	896
2500	853	362	914	453	976	548	1038	650	1097	761	1154	877	1209	990
2750	914	434	974	529	1033	629	1091	739	1146	858	1199	979	1250	1098
3000	980	513	1037	614	1092	720	1146	837	1198	961	1247	1088	1295	1215
3250	1048	598	1101	705	1153	819	1203	941	1251	1071	1298	1206	1343	1343
3500	1116	693	1166	809	1214	931	1261	1060	1307	1198	1351	1341	1395	1489
3750	1185	806	1232	931	1277	1063	1322	1201	1365	1348	1407	1499	1448	1657
4000	1254	937	1299	1072	1341	1214	1383	1363	1424	1518	1464	1679	1503	1844
4250	1324	1089	1366	1234	1406	1386	1445	1545	1484	1708	1522	1876	1559	2046
4500	1395	1262	1433	1417	1471	1579	1508	1745	1544	1913	1581	2084	1616	2256
4750	1465	1455	1501	1619	1536	1787	1571	1957	1606	2128	1641	2299	1675	2470
5000	1534	1666	1568	1834	1602	2004	1635	2174	1668	2345	1701	2514	1735	2682
5250	1603	1887	1635	2055	1667	2224	1699	2392	1731	2559	1763	2724	---	---
5500	1671	2110	1702	2275	1733	2441	1764	2605	---	---	---	---	---	---
5750	1738	2325	1768	2488	---	---	---	---	---	---	---	---	---	---

Total Air Volume cfm	Total Static Pressure - in. w.g.											
	1.6		1.8		2.0		2.2		2.4		2.6	
	RPM	Watts	RPM	Watts	RPM	Watts	RPM	Watts	RPM	Watts	RPM	Watts
1750	1172	833	1231	932	1287	1039	1340	1156	1391	1283	1442	1426
2000	1197	913	1253	1019	1306	1135	1357	1261	1407	1398	1457	1547
2250	1227	1003	1280	1117	1330	1242	1379	1378	1428	1525	1477	1680
2500	1261	1103	1311	1226	1360	1361	1407	1507	1454	1663	1501	1826
2750	1299	1219	1347	1350	1394	1494	1440	1649	1485	1813	1530	1982
3000	1342	1346	1388	1487	1432	1640	1476	1803	1520	1973	1563	2146
3250	1388	1485	1432	1638	1475	1800	1517	1969	1558	2143	1600	2319
3500	1437	1643	1479	1805	1519	1975	1560	2148	1600	2325	1640	2502
3750	1489	1821	1528	1990	1567	2164	1605	2340	1645	2517	1685	2693
4000	1541	2014	1579	2187	1616	2364	1654	2540	1693	2715	1732	2887
4250	1596	2218	1632	2393	1668	2569	1705	2742	1743	2913	---	---
4500	1652	2429	1687	2603	1722	2775	1759	2944	---	---	---	---
4750	1709	2641	1743	2811	1778	2979	---	---	---	---	---	---
5000	1768	2850	---	---	---	---	---	---	---	---	---	---
5250	---	---	---	---	---	---	---	---	---	---	---	---
5500	---	---	---	---	---	---	---	---	---	---	---	---
5750	---	---	---	---	---	---	---	---	---	---	---	---

094 BELT DRIVE BLOWER – BASE UNIT

BLOWER TABLE INCLUDES RESISTANCE FOR BASE UNIT ONLY (NO HEAT SECTION) WITH DRY INDOOR COIL AND AIR FILTERS IN PLACE.

FOR ALL UNITS ADD:

- 1 – Wet indoor coil air resistance of selected unit.
- 2 – Any factory installed options air resistance (heat section, economizer, etc.)
- 3 – Any field installed accessories air resistance (duct resistance, diffuser, etc.)

Then determine from blower table blower motor output required.

See page 33 for blower motors and drives.

See page 33 for wet coil and option/accessory air resistance data.

MINIMUM AIR VOLUME REQUIRED FOR USE WITH OPTIONAL ELECTRIC HEAT (Maximum Static Pressure - 2.0 in. w.g.)

7.5 kW, 15 kW, 22.5 kW, 30 kW and 45 kW - 2800 cfm

Total Air Volume cfm	Total Static Pressure – in. w.g.																											
	0.2		0.4		0.6		0.8		1.0		1.2		1.4		1.6		1.8		2.0		2.2		2.4		2.6			
	RPM	BHP	RPM	BHP	RPM	BHP	RPM	BHP	RPM	BHP	RPM	BHP	RPM	BHP	RPM	BHP	RPM	BHP	RPM	BHP	RPM	BHP	RPM	BHP	RPM	BHP	RPM	BHP
1750	481	0.21	549	0.4	618	0.57	688	0.7	758	0.82	824	0.93	885	1.08	941	1.23	991	1.39	1038	1.54	1082	1.68	1124	1.82	1166	1.95		
2000	493	0.29	561	0.47	629	0.64	700	0.77	768	0.9	832	1.02	892	1.17	946	1.33	995	1.49	1041	1.66	1085	1.81	1126	1.97	1167	2.12		
2250	507	0.37	574	0.56	643	0.72	712	0.86	779	0.99	842	1.13	900	1.28	953	1.44	1001	1.61	1045	1.78	1088	1.95	1128	2.12	1168	2.3		
2500	521	0.46	588	0.64	657	0.81	727	0.95	792	1.09	853	1.24	909	1.4	960	1.57	1007	1.74	1050	1.93	1091	2.11	1130	2.29	1170	2.48		
2750	537	0.56	604	0.74	674	0.91	743	1.06	806	1.21	865	1.36	920	1.53	969	1.71	1014	1.89	1055	2.08	1095	2.27	1133	2.47	1172	2.66		
3000	554	0.67	622	0.86	692	1.02	760	1.18	822	1.34	878	1.5	931	1.68	979	1.86	1021	2.06	1061	2.26	1099	2.46	1136	2.65	1174	2.85		
3250	572	0.78	641	0.98	712	1.15	778	1.32	838	1.49	892	1.66	943	1.84	989	2.03	1030	2.24	1068	2.45	1105	2.65	1141	2.85	1178	3.06		
3500	592	0.9	663	1.12	733	1.3	798	1.47	855	1.65	907	1.83	956	2.02	1000	2.22	1039	2.44	1076	2.65	1111	2.86	1146	3.07	1183	3.27		
3750	614	1.04	687	1.28	756	1.47	818	1.65	872	1.83	923	2.02	970	2.22	1011	2.43	1049	2.65	1084	2.87	1118	3.09	1152	3.29	1189	3.51		
4000	639	1.22	713	1.48	780	1.66	838	1.83	890	2.02	939	2.22	984	2.44	1023	2.66	1059	2.89	1093	3.11	1126	3.33	1160	3.54	1197	3.77		
4250	667	1.43	741	1.69	805	1.86	859	2.02	909	2.22	956	2.45	998	2.68	1036	2.92	1070	3.15	1103	3.37	1135	3.59	1169	3.81	1207	4.05		

122 AND 152 BELT DRIVE BLOWER – BASE UNIT

BLOWER TABLE INCLUDES RESISTANCE FOR BASE UNIT ONLY (NO HEAT SECTION) WITH DRY INDOOR COIL AND AIR FILTERS IN PLACE.

FOR ALL UNITS ADD:

- 1 – Wet indoor coil air resistance of selected unit.
- 2 – Any factory installed options air resistance (heat section, economizer, etc.)
- 3 – Any field installed accessories air resistance (duct resistance, diffuser, etc.)

Then determine from blower table blower motor output required.

See page 33 for blower motors and drives.

See page 33 for wet coil and option/accessory air resistance data.

MINIMUM AIR VOLUME REQUIRED FOR USE WITH OPTIONAL ELECTRIC HEAT (Maximum Static Pressure - 2.0 in. w.g.)

15 kW, 22.5 kW, 30 kW and 45 kW - 2800 cfm

60 kW - 4000 cfm

Total Air Volume cfm	Total Static Pressure – in. w.g.																									
	0.2		0.4		0.6		0.8		1.0		1.2		1.4		1.6		1.8		2.0		2.2		2.4		2.6	
	RPM	BHP	RPM	BHP	RPM	BHP	RPM	BHP	RPM	BHP	RPM	BHP	RPM	BHP	RPM	BHP	RPM	BHP	RPM	BHP	RPM	BHP	RPM	BHP	RPM	BHP
2000	497	0.25	558	0.44	624	0.6	694	0.74	764	0.85	830	0.99	889	1.16	943	1.34	994	1.52	1045	1.71	1096	1.89	1146	2.08	1197	2.27
2250	511	0.34	573	0.52	638	0.68	708	0.82	776	0.94	839	1.09	896	1.26	948	1.45	998	1.64	1048	1.83	1098	2.01	1149	2.2	1200	2.4
2500	527	0.44	589	0.62	654	0.78	723	0.91	789	1.05	850	1.21	904	1.39	955	1.58	1003	1.77	1052	1.96	1101	2.14	1152	2.33	1203	2.53
2750	545	0.55	606	0.72	672	0.88	740	1.03	804	1.17	861	1.34	914	1.53	962	1.72	1010	1.92	1057	2.10	1105	2.29	1154	2.47	1206	2.68
3000	564	0.66	626	0.84	692	1.01	759	1.16	819	1.32	874	1.49	924	1.68	971	1.88	1017	2.08	1063	2.26	1110	2.44	1158	2.63	1208	2.83
3250	585	0.79	648	0.98	714	1.14	778	1.31	836	1.48	887	1.66	935	1.86	981	2.06	1026	2.26	1071	2.45	1117	2.63	1163	2.80	1213	3.00
3500	607	0.93	672	1.13	737	1.31	798	1.48	852	1.66	901	1.85	948	2.05	993	2.26	1037	2.46	1081	2.65	1125	2.83	1171	3.01	1221	3.21
3750	632	1.10	698	1.31	762	1.50	819	1.67	869	1.86	915	2.05	961	2.25	1005	2.47	1049	2.68	1092	2.88	1136	3.05	1181	3.24	1231	3.45
4000	660	1.30	726	1.52	787	1.70	838	1.87	885	2.06	930	2.26	974	2.48	1018	2.71	1062	2.93	1105	3.12	1149	3.30	1194	3.49	1245	3.72
4250	691	1.53	755	1.75	810	1.91	857	2.07	901	2.27	945	2.50	990	2.74	1034	2.98	1077	3.20	1120	3.39	1163	3.58	1210	3.79	1262	4.03
4500	724	1.78	783	1.98	831	2.12	874	2.28	917	2.50	962	2.75	1006	3.02	1051	3.27	1094	3.49	1137	3.70	1181	3.89	1228	4.11	1281	4.38
4750	757	2.05	809	2.20	851	2.33	891	2.51	935	2.76	980	3.05	1025	3.33	1070	3.59	1113	3.82	1156	4.03	1201	4.24	1249	4.47	1303	4.75
5000	787	2.31	831	2.43	870	2.57	910	2.78	954	3.06	1000	3.38	1046	3.68	1091	3.95	1135	4.19	1178	4.40	1224	4.62	1272	4.86	1325	5.13
5250	814	2.55	852	2.66	889	2.83	930	3.09	975	3.41	1023	3.76	1070	4.08	1115	4.35	1159	4.59	1203	4.81	1248	5.03	1297	5.27	1350	5.53
5500	835	2.78	871	2.91	909	3.13	952	3.44	999	3.81	1049	4.18	1096	4.51	1142	4.79	1186	5.03	1229	5.24	1275	5.46	1324	5.69	---	---
5750	854	3.01	890	3.19	930	3.48	977	3.86	1027	4.27	1078	4.66	1126	4.99	1171	5.26	1214	5.49	1258	5.70	---	---	---	---	---	---
6000	871	3.26	910	3.53	955	3.90	1006	4.34	1060	4.80	1111	5.19	1158	5.51	---	---	---	---	---	---	---	---	---	---	---	---
6250	890	3.57	934	3.94	985	4.41	1041	4.91	1096	5.38	---	---	---	---	---	---	---	---	---	---	---	---	---	---	---	---

BLOWER DATA

FACTORY INSTALLED BELT DRIVE KIT SPECIFICATIONS

Motor Efficiency	Nominal hp	Drive Kit Number	RPM Range
Standard & High	2	1	590 - 890
Standard & High	2	2	800 - 1105
Standard & High	2	3	795 - 1195
Standard	3	4	730 - 970
Standard	3	5	940 - 1200
Standard	3	6	1015 - 1300
High	3	7	730 - 970
High	3	8	940 - 1200
High	3	9	1015 - 1300
Standard	5	10	900 - 1135
Standard	5	11	1040 - 1315
Standard	5	12	1125 - 1425

NOTE - Using total air volume and system static pressure requirements determine from blower performance tables rpm and motor output required. Maximum usable output of motors furnished are shown. If motors of comparable output are used, be sure to keep within the service factor limitations outlined on the motor nameplate.

POWER EXHAUST FAN PERFORMANCE

Return Air System Static Pressure	Air Volume Exhausted
in. w.g.	cfm
0	3175
0.05	2955
0.10	2685
0.15	2410
0.20	2165
0.25	1920
0.30	1420
0.35	1200

FACTORY INSTALLED OPTIONS/FIELD INSTALLED ACCESSORY AIR RESISTANCE - in. w.g.

Air Volume cfm	Wet Indoor Coil		Electric Heat	Economizer	Filters		Return Air Adaptor Plate
	094	122, 152			MERV 8	MERV 13	
1750	0.04	0.04	0.03	0.05	0.01	0.03	0.00
2000	0.05	0.05	0.03	0.06	0.01	0.03	0.00
2250	0.06	0.06	0.04	0.08	0.01	0.04	0.00
2500	0.07	0.07	0.04	0.11	0.01	0.05	0.00
2750	0.08	0.08	0.05	0.12	0.02	0.05	0.00
3000	0.10	0.09	0.06	0.13	0.02	0.06	0.02
3250	0.11	0.10	0.06	0.15	0.02	0.06	0.02
3500	0.12	0.11	0.09	0.15	0.03	0.07	0.04
3750	0.14	0.13	0.09	0.15	0.03	0.08	0.07
4000	0.15	0.14	0.09	0.19	0.04	0.08	0.09
4250	0.17	0.15	0.13	0.19	0.04	0.09	0.11
4500	0.19	0.17	0.14	0.22	0.04	0.09	0.12
4750	0.20	0.18	0.17	0.25	0.05	0.10	0.16
5000	0.22	0.20	0.20	0.29	0.06	0.10	0.18
5250	0.24	0.22	0.22	0.32	0.06	0.11	0.19
5500	0.25	0.23	0.25	0.34	0.07	0.12	0.22
5750	0.27	0.25	0.31	0.45	0.07	0.12	0.25
6000	0.29	0.27	0.33	0.52	0.08	0.13	0.27

BLOWER DATA

CEILING DIFFUSERS AIR RESISTANCE - in. w.g.

Unit Size	RTD11 Step-Down Diffuser				FD11 Flush Diffuser
	Air Volume cfm	2 Ends Open	1 Side, 2 Ends Open	All Ends & Sides Open	
094 Models	2400	0.21	0.18	0.15	0.14
	2600	0.24	0.21	0.18	0.17
	2800	0.27	0.24	0.21	0.20
	3000	0.32	0.29	0.25	0.25
	3200	0.41	0.37	0.32	0.31
	3400	0.50	0.45	0.39	0.37
	3600	0.61	0.54	0.48	0.44
122 Models	3600	0.36	0.28	0.23	0.15
	3800	0.40	0.32	0.26	0.18
	4000	0.44	0.36	0.29	0.21
	4200	0.49	0.40	0.33	0.24
	4400	0.54	0.44	0.37	0.27
	4600	0.60	0.49	0.42	0.31
	4800	0.65	0.53	0.46	0.35
	5000	0.69	0.58	0.50	0.39
152 Models	5200	0.75	0.62	0.54	0.43
	4200	0.22	0.19	0.16	0.10
	4400	0.28	0.24	0.20	0.12
	4600	0.34	0.29	0.24	0.15
	4800	0.40	0.34	0.29	0.19
	5000	0.46	0.39	0.34	0.23
	5200	0.52	0.44	0.39	0.27
	5400	0.58	0.49	0.43	0.31
5600	0.64	0.54	0.47	0.35	
5800	0.70	0.59	0.51	0.39	

CEILING DIFFUSER AIR THROW DATA

Model No.	Air Volume cfm	¹ Effective Throw Range	
		RTD11 Step-Down	FD11 Flush
		ft.	ft.
094 Models	2600	24 - 29	19 - 24
	2800	25 - 30	20 - 28
	3000	27 - 33	21 - 29
	3200	28 - 35	22 - 29
	3400	30 - 37	22 - 30
122 Models	3600	25 - 33	22 - 29
	3800	27 - 35	22 - 30
	4000	29 - 37	24 - 33
	4200	32 - 40	26 - 35
	4400	34 - 42	28 - 37
152 Models	5600	39 - 49	28 - 37
	5800	42 - 51	29 - 38
	6000	44 - 54	40 - 50
	6200	45 - 55	42 - 51
	6400	46 - 55	43 - 52
6600	47 - 56	45 - 56	

¹ Throw is the horizontal or vertical distance an air stream travels on leaving the outlet or diffuser before the maximum velocity is reduced to 50 ft. per minute. Four sides open.

ELECTRICAL/ELECTRIC HEAT DATA

DIRECT DRIVE | 7.5 TON

Model No.		LCH094U4E		
¹ Voltage - 60hz		208/230V - 3 Ph	460V - 3 Ph	575V - 3 Ph
Compressor 1	Rated Load Amps	13.1	6.1	4.4
	Locked Rotor Amps	83.1	41	33
Compressor 2	Rated Load Amps	13.1	6.1	4.4
	Locked Rotor Amps	83.1	41	33
Outdoor Fan Motors (3)	Full Load Amps	2.8	1.4	1.1
	(total)	(8.4)	(4.2)	(3.3)
Power Exhaust (1) 0.33 HP	Full Load Amps	2.4	1.3	1
Service Outlet 115V GFI (amps)		15	15	20
Indoor Blower Motor	Horsepower	3.75	3.75	3.75
	Full Load Amps	8.8	4.3	3.4
² Maximum Overcurrent Protection	Unit Only	50	25	20
	With (1) 0.33 HP Power Exhaust	60	25	20
³ Minimum Circuit Ampacity	Unit Only	47	23	17
	With (1) 0.33 HP Power Exhaust	50	24	18

ELECTRIC HEAT DATA

Electric Heat Voltage			208V	240V	480V	600V
² Maximum Overcurrent Protection	Unit+ Electric Heat	7.5 kW	50	50	25	20
		15 kW	60	60	30	25
		22.5 kW	⁴ 70	80	40	35
		30 kW	⁴ 90	110	60	45
		45 kW	150	150	80	60
³ Minimum Circuit Ampacity	Unit+ Electric Heat	7.5 kW	47	47	23	17
		15 kW	51	57	28	23
		22.5 kW	70	79	40	32
		30 kW	90	102	51	41
		45 kW	129	147	74	59
² Maximum Overcurrent Protection	Unit+ Electric Heat and (1) 0.33 HP Power Exhaust	7.5 kW	60	60	25	20
		15 kW	60	60	30	25
		22.5 kW	⁴ 80	90	45	35
		30 kW	⁴ 100	110	60	45
		45 kW	150	150	80	60
³ Minimum Circuit Ampacity	Unit+ Electric Heat and (1) 0.33 HP Power Exhaust	7.5 kW	50	50	24	18
		15 kW	54	60	30	24
		22.5 kW	73	82	41	33
		30 kW	93	105	53	42
		45 kW	132	150	75	60

ELECTRICAL ACCESSORIES

Disconnect	7.5 kW	54W56	54W56	54W56	54W56
	15 kW	54W56	54W56	54W56	54W56
	22.5 kW	54W56	54W56	54W56	54W56
	30 kW	54W57	54W57	54W56	54W56
	45 kW	54W57	54W57	54W56	54W56

NOTE - All units have a minimum Short Circuit Current Rating (SCCR) of 5000 amps.

¹ Extremes of operating range are plus and minus 10% of line voltage.

² HACR type breaker or fuse.

³ Refer to National or Canadian Electrical Code manual to determine wire, fuse and disconnect size requirements.

⁴ Factory installed circuit breaker not available.

ELECTRICAL/ELECTRIC HEAT DATA

DIRECT DRIVE | 10 TON

Model No.		LCH122U4E		
¹ Voltage - 60hz		208/230V - 3 Ph	460V - 3 Ph	575V - 3 Ph
Compressor 1	Rated Load Amps	16	7.8	5.7
	Locked Rotor Amps	110	52	38.9
Compressor 2	Rated Load Amps	16	7.8	5.7
	Locked Rotor Amps	110	52	38.9
Outdoor Fan Motors (3)	Full Load Amps	2.8	1.4	1.1
	(total)	(8.4)	(4.2)	(3.3)
Power Exhaust (1) 0.33 HP	Full Load Amps	2.4	1.3	1
Service Outlet 115V GFI (amps)		15	15	20
Indoor Blower Motor	Horsepower	3.75	3.75	3.75
	Full Load Amps	8.8	4.3	3.4
² Maximum Overcurrent Protection	Unit Only	60	30	25
	With (1) 0.33 HP Power Exhaust	70	35	25
³ Minimum Circuit Ampacity	Unit Only	54	27	20
	With (1) 0.33 HP Power Exhaust	56	28	21

ELECTRIC HEAT DATA

Electric Heat Voltage			208V	240V	480V	600V
² Maximum Overcurrent Protection	Unit+ Electric Heat	15 kW	60	60	30	25
		22.5 kW	⁴ 70	80	40	35
		30 kW	⁴ 90	110	60	45
		45 kW	150	150	80	60
		60 kW	⁴ 150	175	80	70
³ Minimum Circuit Ampacity	Unit+ Electric Heat	15 kW	54	57	28	23
		22.5 kW	70	79	40	32
		30 kW	90	102	51	41
		45 kW	129	147	74	59
		60 kW	137	156	78	62
² Maximum Overcurrent Protection	Unit+ Electric Heat and (1) 0.33 HP Power Exhaust	15 kW	70	70	35	25
		22.5 kW	⁴ 80	90	45	35
		30 kW	⁴ 100	110	60	45
		45 kW	150	150	80	60
		60 kW	⁴ 150	175	80	70
³ Minimum Circuit Ampacity	Unit+ Electric Heat and (1) 0.33 HP Power Exhaust	15 kW	56	60	30	24
		22.5 kW	73	82	41	33
		30 kW	93	105	53	42
		45 kW	132	150	75	60
		60 kW	140	159	80	64

ELECTRICAL ACCESSORIES

Disconnect	15 kW	54W56	54W56	54W56	54W56
	22.5 kW	54W56	54W56	54W56	54W56
	30 kW	54W57	54W57	54W56	54W56
	45 kW	54W57	54W57	54W56	54W56
	60 kW	N/A	N/A	54W57	54W56

NOTE - All units have a minimum Short Circuit Current Rating (SCCR) of 5000 amps.

¹ Extremes of operating range are plus and minus 10% of line voltage.

² HACR type breaker or fuse.

³ Refer to National or Canadian Electrical Code manual to determine wire, fuse and disconnect size requirements.

⁴ Factory installed circuit breaker not available.

ELECTRICAL/ELECTRIC HEAT DATA

DIRECT DRIVE | 12.5 TON

Model No.		LCH152U4E		
¹ Voltage - 60hz		208/230V - 3 Ph	460V - 3 Ph	575V - 3 Ph
Compressor 1	Rated Load Amps	19.6	8.2	6.6
	Locked Rotor Amps	136	66.1	55.3
Compressor 2	Rated Load Amps	19.6	8.2	6.6
	Locked Rotor Amps	136	66.1	55.3
Outdoor Fan Motors (3)	Full Load Amps	2.8	1.4	1.1
	(total)	(8.4)	(4.2)	(3.3)
Power Exhaust (1) 0.33 HP	Full Load Amps	2.4	1.3	1
Service Outlet 115V GFI (amps)		15	15	20
Indoor Blower Motor	Horsepower	3.75	3.75	3.75
	Full Load Amps	8.8	4.3	3.4
² Maximum Overcurrent Protection	Unit Only	80	35	25
	With (1) 0.33 HP Power Exhaust	80	35	25
³ Minimum Circuit Ampacity	Unit Only	62	27	22
	With (1) 0.33 HP Power Exhaust	64	29	23

ELECTRIC HEAT DATA

Electric Heat Voltage			208V	240V	480V	600V
² Maximum Overcurrent Protection	Unit+ Electric Heat	15 kW	80	80	35	25
		22.5 kW	80	80	40	35
		30 kW	⁴ 90	110	60	45
		45 kW	150	150	80	60
		60 kW	⁴ 150	175	80	70
³ Minimum Circuit Ampacity	Unit+ Electric Heat	15 kW	62	62	28	23
		22.5 kW	70	79	40	32
		30 kW	90	102	51	41
		45 kW	129	147	74	59
		60 kW	137	156	78	62
² Maximum Overcurrent Protection	Unit+ Electric Heat and (1) 0.33 HP Power Exhaust	15 kW	80	80	35	25
		22.5 kW	⁴ 80	90	45	35
		30 kW	⁴ 100	110	60	45
		45 kW	150	150	80	60
		60 kW	⁴ 150	175	80	70
³ Minimum Circuit Ampacity	Unit+ Electric Heat and (1) 0.33 HP Power Exhaust	15 kW	64	64	30	24
		22.5 kW	73	82	41	33
		30 kW	93	105	53	42
		45 kW	132	150	75	60
		60 kW	140	159	80	64

ELECTRICAL ACCESSORIES

Disconnect	15 kW	54W56	54W56	54W56	54W56
	22.5 kW	54W56	54W56	54W56	54W56
	30 kW	54W57	54W57	54W56	54W56
	45 kW	54W57	54W57	54W56	54W56
	60 kW	N/A	N/A	54W57	54W56

NOTE - All units have a minimum Short Circuit Current Rating (SCCR) of 5000 amps.

¹ Extremes of operating range are plus and minus 10% of line voltage.

² HACR type breaker or fuse.

³ Refer to National or Canadian Electrical Code manual to determine wire, fuse and disconnect size requirements.

⁴ Factory installed circuit breaker not available.

ELECTRICAL/ELECTRIC HEAT DATA

BELT DRIVE | 7.5 TON

Model No.		LCH094U4M								
¹ Voltage - 60hz		208/230V - 3 Ph			460V - 3 Ph			575V - 3 Ph		
Compressor 1	Rated Load Amps	13.1			6.1			4.4		
	Locked Rotor Amps	83.1			41			33		
Compressor 2	Rated Load Amps	13.1			6.1			4.4		
	Locked Rotor Amps	83.1			41			33		
Outdoor Fan Motors (3)	Full Load Amps	2.8			1.4			1.1		
	(total)	(8.4)			(4.2)			(3.3)		
Power Exhaust (1) 0.33 HP	Full Load Amps	2.4			1.3			1		
Service Outlet 115V GFI (amps)		15			15			20		
Indoor Blower Motor	Horsepower	2	3	5	2	3	5	2	3	5
	Full Load Amps	7.5	10.6	16.7	3.4	4.8	7.6	2.7	3.9	6.1
² Maximum Overcurrent Protection	Unit Only	50	60	70	25	25	30	20	20	25
	With (1) 0.33 HP Power Exhaust	60	60	70	25	30	30	20	20	25
³ Minimum Circuit Ampacity	Unit Only	46	49	56	22	23	26	16	18	20
	With (1) 0.33 HP Power Exhaust	48	51	58	23	25	28	17	19	21

ELECTRIC HEAT DATA

Electric Heat Voltage			208V	240V	208V	240V	208V	240V	480V	480V	480V	600V	600V	600V
² Maximum Overcurrent Protection	Unit+ Electric Heat	7.5 kW	50	50	60	60	70	70	25	25	30	20	20	25
		15 kW	⁴ 50	60	60	60	70	70	30	30	35	25	25	30
		22.5 kW	⁴ 70	80	⁴ 80	90	⁴ 80	90	40	40	45	35	35	35
		30 kW	⁴ 90	100	⁴ 100	110	⁴ 100	125	50	60	60	40	45	45
		45 kW	150	150	150	150	⁴ 150	175	80	80	80	60	60	70
³ Minimum Circuit Ampacity	Unit+ Electric Heat	7.5 kW	46	46	49	49	56	56	22	23	26	16	18	20
		15 kW	49	55	53	59	60	66	27	29	33	22	23	26
		22.5 kW	69	78	72	81	80	89	39	40	44	31	32	35
		30 kW	88	100	92	104	100	112	50	52	55	40	41	44
		45 kW	127	145	131	149	139	157	72	74	78	58	60	62
² Maximum Overcurrent Protection	Unit+ Electric Heat and (1) 0.33 HP Power Exhaust	7.5 kW	60	60	60	60	70	70	25	30	30	20	20	25
		15 kW	60	60	⁴ 60	70	70	70	30	35	35	25	25	30
		22.5 kW	⁴ 80	90	⁴ 80	90	⁴ 90	100	40	45	45	35	35	40
		30 kW	⁴ 100	110	⁴ 100	110	⁴ 110	125	60	60	60	45	45	45
		45 kW	150	150	⁴ 150	175	⁴ 150	175	80	80	80	60	70	70
³ Minimum Circuit Ampacity	Unit+ Electric Heat and (1) 0.33 HP Power Exhaust	7.5 kW	48	48	51	51	58	58	23	25	28	17	19	21
		15 kW	52	58	56	62	63	69	29	31	34	23	25	27
		22.5 kW	72	81	75	84	83	92	40	42	45	32	34	36
		30 kW	91	103	95	107	103	115	51	53	57	41	43	45
		45 kW	130	148	134	152	142	160	74	76	79	59	61	64

ELECTRICAL ACCESSORIES

Disconnect	7.5 kW	54W56	54W56	54W56	54W56	54W56	54W56	54W56	54W56	54W56	54W56	54W56	54W56	54W56
	15 kW	54W56	54W56	54W56	54W56	54W56	54W56	54W56	54W56	54W56	54W56	54W56	54W56	54W56
	22.5 kW	54W56	54W56	54W56	54W56	54W57	54W57	54W56	54W56	54W56	54W56	54W56	54W56	54W56
	30 kW	54W57	54W57	54W57	54W57	54W57	54W57	54W56	54W56	54W56	54W56	54W56	54W56	54W56
	45 kW	54W57	54W57	54W57	54W57	54W57	54W57	54W56	54W56	54W56	54W56	54W56	54W56	54W56

NOTE - All units have a minimum Short Circuit Current Rating (SCCR) of 5000 amps.

¹ Extremes of operating range are plus and minus 10% of line voltage.

² HACR type breaker or fuse.

³ Refer to National or Canadian Electrical Code manual to determine wire, fuse and disconnect size requirements.

⁴ Factory installed circuit breaker not available.

ELECTRICAL/ELECTRIC HEAT DATA

BELT DRIVE | 10 TON

Model No.		LCH122U4M								
¹ Voltage - 60hz		208/230V - 3 Ph			460V - 3 Ph			575V - 3 Ph		
Compressor 1	Rated Load Amps	16.5			7.2			5.5		
	Locked Rotor Amps	110			52			38.9		
Compressor 2	Rated Load Amps	16			7.8			5.7		
	Locked Rotor Amps	110			52			38.9		
Outdoor Fan Motors (3)	Full Load Amps	2.8			1.4			1.1		
	(total)	(8.4)			(4.2)			(3.3)		
Power Exhaust (1) 0.33 HP	Full Load Amps	2.4			1.3			1		
Service Outlet 115V GFI (amps)		15			15			20		
Indoor Blower Motor	Horsepower	2	3	5	2	3	5	2	3	5
	Full Load Amps	7.5	10.6	16.7	3.4	4.8	7.6	2.7	3.9	6.1
² Maximum Overcurrent Protection	Unit Only	60	70	70	30	30	35	20	25	25
	With (1) 0.33 HP Power Exhaust	70	70	80	30	35	35	25	25	25
³ Minimum Circuit Ampacity	Unit Only	53	56	62	25	26	29	19	20	23
	With (1) 0.33 HP Power Exhaust	55	59	65	26	28	31	20	21	24

ELECTRIC HEAT DATA

Electric Heat Voltage			208V	240V	208V	240V	208V	240V	480V	480V	480V	600V	600V	600V
² Maximum Overcurrent Protection	Unit+	15 kW	60	60	70	70	70	70	30	30	35	25	25	30
	Electric Heat and (1) 0.33 HP Power Exhaust	22.5 kW	⁴ 70	80	⁴ 80	90	⁴ 80	90	40	40	45	35	35	35
		30 kW	⁴ 90	100	⁴ 100	110	⁴ 100	125	50	60	60	40	45	45
		45 kW	150	150	150	150	⁴ 150	175	80	80	80	60	60	70
		60 kW	⁴ 150	175	⁴ 150	175	⁴ 150	175	80	80	90	70	70	70
³ Minimum Circuit Ampacity	Unit+	15 kW	53	55	56	59	62	66	27	29	33	22	23	26
	Electric Heat and (1) 0.33 HP Power Exhaust	22.5 kW	69	78	72	81	80	89	39	40	44	31	32	35
		30 kW	88	100	92	104	100	112	50	52	55	40	41	44
		45 kW	127	145	131	149	139	157	72	74	78	58	60	62
		60 kW	135	154	139	158	146	166	77	79	82	62	63	66
² Maximum Overcurrent Protection	Unit+	15 kW	70	70	70	70	80	80	30	35	35	25	25	30
	Electric Heat and (1) 0.33 HP Power Exhaust	22.5 kW	⁴ 80	90	⁴ 80	90	⁴ 90	100	40	45	45	35	35	40
		30 kW	⁴ 100	110	⁴ 100	110	⁴ 110	125	60	60	60	45	45	45
		45 kW	150	150	⁴ 150	175	⁴ 150	175	80	80	80	60	70	70
		60 kW	⁴ 150	175	⁴ 150	175	⁴ 150	175	80	80	90	70	70	70
³ Minimum Circuit Ampacity	Unit+	15 kW	55	58	59	62	65	69	29	31	34	23	25	27
	Electric Heat and (1) 0.33 HP Power Exhaust	22.5 kW	72	81	75	84	83	92	40	42	45	32	34	36
		30 kW	91	103	95	107	103	115	51	53	57	41	43	45
		45 kW	130	148	134	152	142	160	74	76	79	59	61	64
		60 kW	138	157	142	161	149	169	79	80	84	63	64	67

ELECTRICAL ACCESSORIES

Disconnect	15 kW	54W56	54W56	54W56	54W56	54W56	54W56	54W56	54W56	54W56	54W56	54W56	54W56	54W56
	22.5 kW	54W56	54W56	54W56	54W56	54W57	54W57	54W56	54W56	54W56	54W56	54W56	54W56	54W56
	30 kW	54W57	54W57	54W57	54W57	54W57	54W57	54W56	54W56	54W56	54W56	54W56	54W56	54W56
	45 kW	54W57	54W57	54W57	54W57	54W57	54W57	54W56	54W56	54W56	54W56	54W56	54W56	54W56
	60 kW	N/A	N/A	N/A	N/A	N/A	N/A	54W57	54W57	54W57	54W56	54W56	54W56	54W56

NOTE - All units have a minimum Short Circuit Current Rating (SCCR) of 5000 amps.

¹ Extremes of operating range are plus and minus 10% of line voltage.

² HACR type breaker or fuse.

³ Refer to National or Canadian Electrical Code manual to determine wire, fuse and disconnect size requirements.

⁴ Factory installed circuit breaker not available.

⁵ Disconnect must be field furnished.

ELECTRICAL/ELECTRIC HEAT DATA

BELT DRIVE | 12.5 TON

Model No.		LCH152U4M								
¹ Voltage - 60hz		208/230V - 3 Ph			460V - 3 Ph			575V - 3 Ph		
Compressor 1	Rated Load Amps	19.6			8.2			6.6		
	Locked Rotor Amps	136			66.1			55.3		
Compressor 2	Rated Load Amps	19.6			8.2			6.6		
	Locked Rotor Amps	136			66.1			55.3		
Outdoor Fan Motors (3)	Full Load Amps	2.8			1.4			1.1		
	(total)	(8.4)			(4.2)			(3.3)		
Power Exhaust (1) 0.33 HP	Full Load Amps	2.4			1.3			1		
Service Outlet 115V GFI (amps)		15			15			20		
Indoor Blower Motor	Horsepower	2	3	5	2	3	5	2	3	5
	Full Load Amps	7.5	10.6	16.7	3.4	4.8	7.6	2.7	3.9	6.1
² Maximum Overcurrent Protection	Unit Only	70	80	80	30	35	35	25	25	30
	With (1) 0.33 HP Power Exhaust	80	80	90	35	35	35	25	25	30
³ Minimum Circuit Ampacity	Unit Only	60	64	70	27	28	31	21	23	25
	With (1) 0.33 HP Power Exhaust	63	66	72	28	29	32	22	24	26

ELECTRIC HEAT DATA

Electric Heat Voltage			208V	240V	208V	240V	208V	240V	480V	480V	480V	600V	600V	600V
² Maximum Overcurrent Protection	Unit+ Electric Heat	15 kW	70	70	80	80	80	80	30	35	35	25	25	30
		22.5 kW	⁴ 70	80	⁴ 80	90	⁴ 80	90	40	40	45	35	35	35
		30 kW	⁴ 90	100	⁴ 100	110	⁴ 100	125	50	60	60	40	45	45
		45 kW	150	150	150	150	⁴ 150	175	80	80	80	60	60	70
		60 kW	⁴ 150	175	⁴ 150	175	⁴ 150	175	80	80	90	70	70	70
³ Minimum Circuit Ampacity	Unit+ Electric Heat	15 kW	60	60	64	64	70	70	27	29	33	22	23	26
		22.5 kW	69	78	72	81	80	89	39	40	44	31	32	35
		30 kW	88	100	92	104	100	112	50	52	55	40	41	44
		45 kW	127	145	131	149	139	157	72	74	78	58	60	62
		60 kW	135	154	139	158	146	166	77	79	82	62	63	66
² Maximum Overcurrent Protection	Unit+ Electric Heat and (1) 0.33 HP Power Exhaust	15 kW	80	80	80	80	90	90	35	35	35	25	25	30
		22.5 kW	⁴ 80	90	⁴ 80	90	⁴ 90	100	40	45	45	35	35	40
		30 kW	⁴ 100	110	⁴ 100	110	⁴ 110	125	60	60	60	45	45	45
		45 kW	150	150	⁴ 150	175	⁴ 150	175	80	80	80	60	70	70
		60 kW	⁴ 150	175	⁴ 150	175	⁴ 150	175	80	80	90	70	70	70
³ Minimum Circuit Ampacity	Unit+ Electric Heat and (1) 0.33 HP Power Exhaust	15 kW	63	63	66	66	72	72	29	31	34	23	25	27
		22.5 kW	72	81	75	84	83	92	40	42	45	32	34	36
		30 kW	91	103	95	107	103	115	51	53	57	41	43	45
		45 kW	130	148	134	152	142	160	74	76	79	59	61	64
		60 kW	138	157	142	161	149	169	79	80	84	63	64	67

ELECTRICAL ACCESSORIES

Disconnect	15 kW	54W56	54W56	54W56	54W56	54W56	54W56	54W56	54W56	54W56	54W56	54W56	54W56	54W56
	22.5 kW	54W56	54W56	54W56	54W56	54W57	54W57	54W56	54W56	54W56	54W56	54W56	54W56	54W56
	30 kW	54W57	54W57	54W57	54W57	54W57	54W57	54W56	54W56	54W56	54W56	54W56	54W56	54W56
	45 kW	54W57	54W57	54W57	54W57	54W57	54W57	54W56	54W56	54W56	54W56	54W56	54W56	54W56
	60 kW	N/A	N/A	N/A	N/A	N/A	N/A	54W57	54W57	54W57	54W56	54W56	54W56	54W56

NOTE - All units have a minimum Short Circuit Current Rating (SCCR) of 5000 amps.

¹ Extremes of operating range are plus and minus 10% of line voltage.

² HACR type breaker or fuse.

³ Refer to National or Canadian Electrical Code manual to determine wire, fuse and disconnect size requirements.

⁴ Factory installed circuit breaker not available.

⁵ Disconnect must be field furnished.

ELECTRIC HEAT CAPACITIES

Volts Input	7.5 kW			15 kW			22.5 kW			30 kW			45 kW			60 kW		
	kW Input	Btuh Output	No. of Stages	kW Input	Btuh Output	No. of Stages	kW Input	Btuh Output	No. of Stages	kW Input	Btuh Output	No. of Stages	kW Input	Btuh Output	No. of Stages	kW Input	Btuh Output	No. of Stages
208	5.6	19,100	1	11.3	38,600	1	16.9	57,700	2	22.5	76,800	2	33.8	115,300	2	45.0	153,600	2
220	6.3	21,500	1	12.6	43,000	1	18.9	64,500	2	25.2	86,000	2	37.8	129,000	2	50.4	172,000	2
230	6.9	23,600	1	13.8	47,100	1	20.7	70,700	2	27.5	93,900	2	41.3	141,000	2	55.1	188,000	2
240	7.5	25,600	1	15.0	51,200	1	22.5	76,800	2	30.0	102,400	2	45.0	153,600	2	60.0	204,800	2
440	6.9	21,500	1	12.6	43,000	1	18.9	64,500	2	25.2	86,000	2	37.8	129,000	2	50.4	172,000	2
460	6.9	23,600	1	13.8	47,100	1	20.7	70,700	2	27.5	93,900	2	41.3	141,000	2	55.1	188,000	2
480	7.5	25,600	1	15.0	51,200	1	22.5	76,800	2	30.0	102,400	2	45.0	153,600	2	60.0	204,800	2
550	6.3	21,500	1	12.6	43,000	1	18.9	64,500	2	25.2	86,000	2	37.8	129,000	2	50.4	172,000	2
575	6.9	23,600	1	13.8	47,100	1	20.7	70,700	2	27.5	93,900	2	41.3	141,000	2	55.1	188,000	2
600	7.5	25,600	1	15.0	51,200	1	22.5	76,800	2	30.0	102,400	2	45.0	153,600	2	60.0	204,800	2

UNIT CLEARANCES

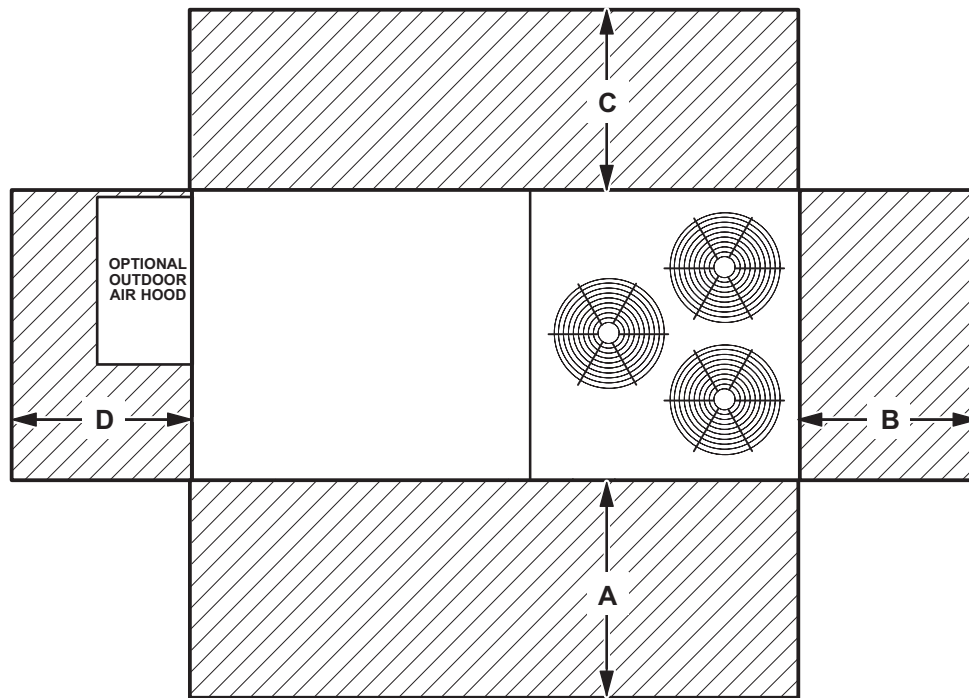

¹ Unit Clearance	A		B		C		D		Top Clearance
	in.	mm	in.	mm	in.	mm	in.	mm	
Service Clearance	60	1524	36	914	36	934	60	1524	Unobstructed
Minimum Operation Clearance	36	914	36	914	36	914	36	914	

NOTE - Entire perimeter of unit base requires support when elevated above the mounting surface.

¹ Service Clearance - Required for removal of serviceable parts.

Minimum Operation Clearance - Required clearance for proper unit operation.

OUTDOOR SOUND DATA

Unit Model	Octave Band Sound Power Levels dBA, re 10 ⁻¹² Watts - Center Frequency - Hz							¹ Sound Rating Number (dBA)
	125	250	500	1000	2000	4000	8000	
All Models	85	81	80	76	70	65	62	81

Note - The octave sound power data does not include tonal corrections.

¹ Sound Rating Number according to AHRI Standard 370-2001 (includes pure tone penalty). Sound Rating Number is the overall A-Weighted Sound Power Level, (LWA), dBA (100 Hz to 10,000 Hz).

WEIGHT DATA

Model Number	Net		Shipping	
	lbs.	kg	lbs.	kg
094U4E Base Unit	1212	550	1297	588
094U4E Max. Unit	1369	621	1454	660
122U4E Base Unit	1222	598	1307	636
122U4E Max. Unit	1386	554	1471	667
152U4E Base Unit	1232	559	1317	597
152U4E Max. Unit	1396	633	1481	672
094U4M Base Unit	1212	550	1297	588
094U4M Max. Unit	1369	621	1454	660
122U4M Base Unit	1222	598	1307	636
122U4M Max. Unit	1386	554	1471	667
152U4M Base Unit	1232	559	1317	597
152U4M Max. Unit	1396	633	1481	672

WEIGHT DATA - OPTIONS / ACCESSORIES

Description	Shipping Weight	
	lbs.	kg
ECONOMIZER / OUTDOOR AIR / EXHAUST		
Economizer		
Economizer Dampers	60	27
Outdoor Air Hood (downflow)	23	10
Barometric Relief Dampers (downflow)	8	4
Barometric Relief Dampers (low profile horizontal)	20	9
Outdoor Air Dampers		
Outdoor Air Damper Section - Automatic	51	23
Outdoor Air Damper Section - Manual	39	18
Power Exhaust	31	14
ELECTRIC HEAT		
7.5 kW	50	23
15 kW	50	23
22.5 kW	57	26
30 kW	57	26
45 kW	59	27
60 kW	68	31
ROOF CURBS		
Hybrid Roof Curbs, Downflow		
8 in. height	60	27
14 in. height	85	39
18 in. height	100	45
24 in. height	125	57
Adjustable Pitch Curb, Downflow		
14 in. height	191	82
CEILING DIFFUSERS		
Step-Down		
RTD11-95S	118	54
RTD11-135S	135	61
RTD11-185S	168	76
Flush		
FD11-95S	118	54
FD11-135S	135	61
FD11-185S	168	76
Transitions		
C1DIFF30B-1	30	14
C1DIFF31B-1	32	15
C1DIFF32B-1	36	16
PACKAGING		
LTL Packaging (less than truck load)	105	48

DIMENSIONS - UNIT

Model No.	CORNER WEIGHTS												CENTER OF GRAVITY											
	AA				BB				CC				DD				EE				FF			
	Base		Max.		Base		Max.		Base		Max.		Base		Max.		Base		Max.		Base		Max.	
	lbs.	kg	lbs.	kg	lbs.	kg	lbs.	kg	lbs.	kg	lbs.	kg	lbs.	kg	lbs.	kg	in.	mm	in.	mm	in.	mm	in.	mm
094	296	134	353	160	214	97	247	112	294	133	317	144	407	185	453	205	52.25	1327	51.25	1302	25.25	641	26.25	667
122	299	136	357	162	216	98	250	113	297	135	321	146	411	186	459	208	52.25	1327	51.25	1302	25.25	641	26.25	667
152	301	137	359	163	218	99	251	114	299	136	323	147	414	188	462	210	52.25	1327	51.25	1302	25.25	641	26.25	667

Base Unit - The unit with NO INTERNAL OPTIONS.

Max. Unit - The unit with ALL INTERNAL OPTIONS Installed. (Economizer, Standard Static Power Exhaust Fans, Controls, etc.). Does not include accessories external to unit or high static power exhaust.

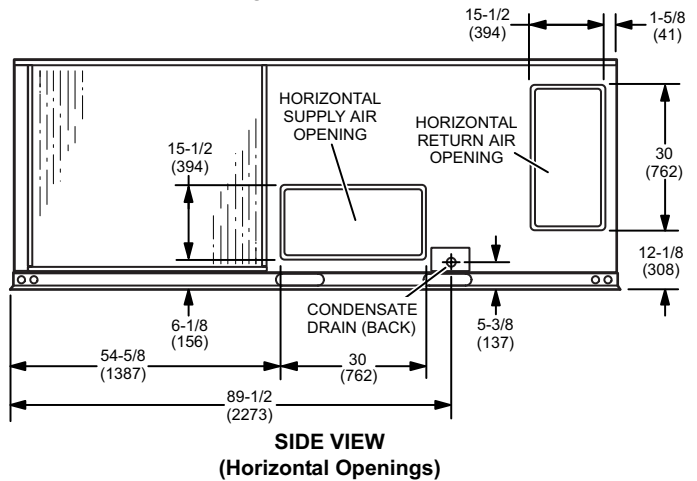
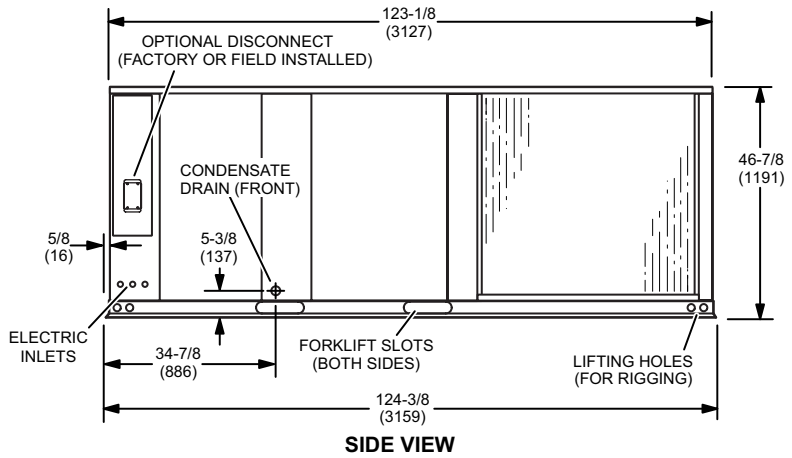
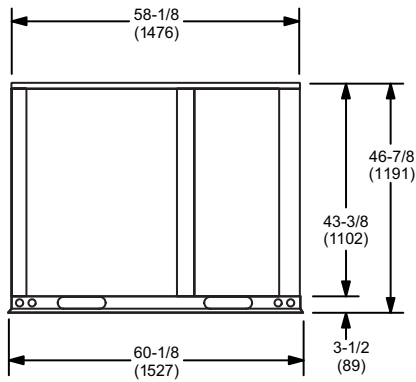
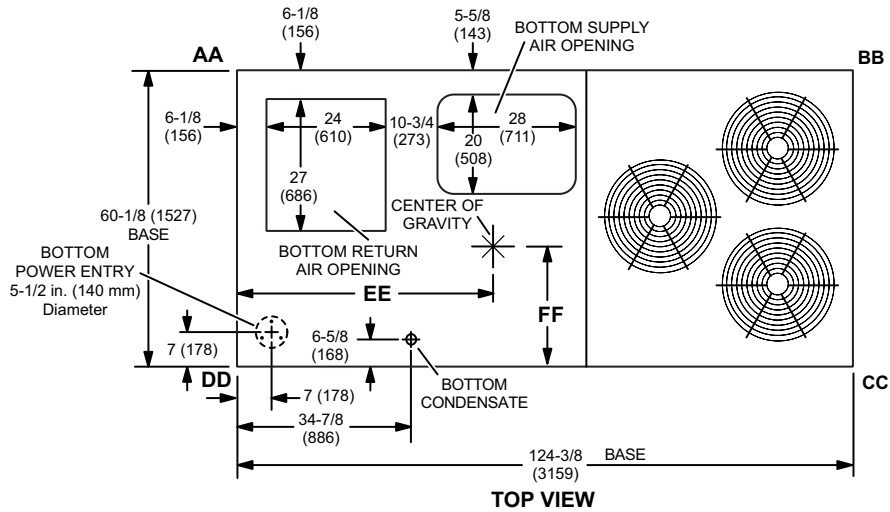

UNIT ON CURB LOCATION

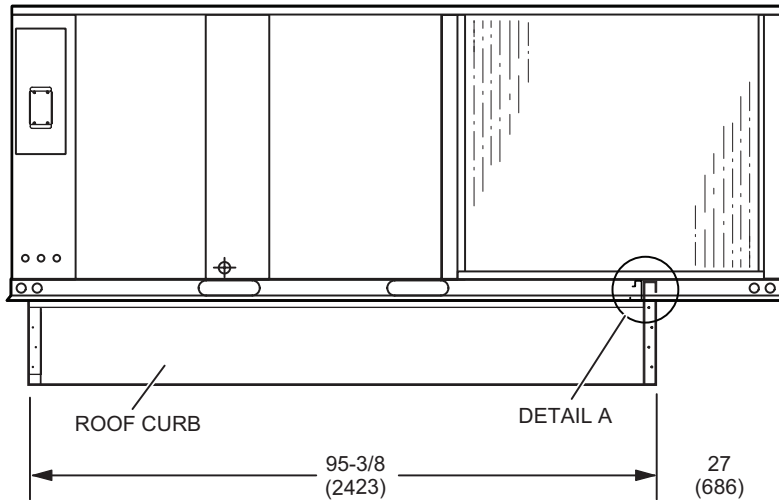

SIDE VIEW

UNIT BASE RAIL

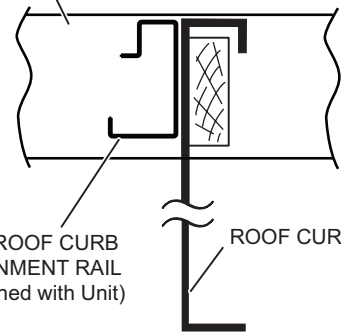

UNIT/ROOF CURB
ALIGNMENT RAIL
(Furnished with Unit)

ROOF CURB

DETAIL A

NOTE - Unit cannot be installed on a full perimeter curb!

OUTDOOR AIR HOOD DETAIL

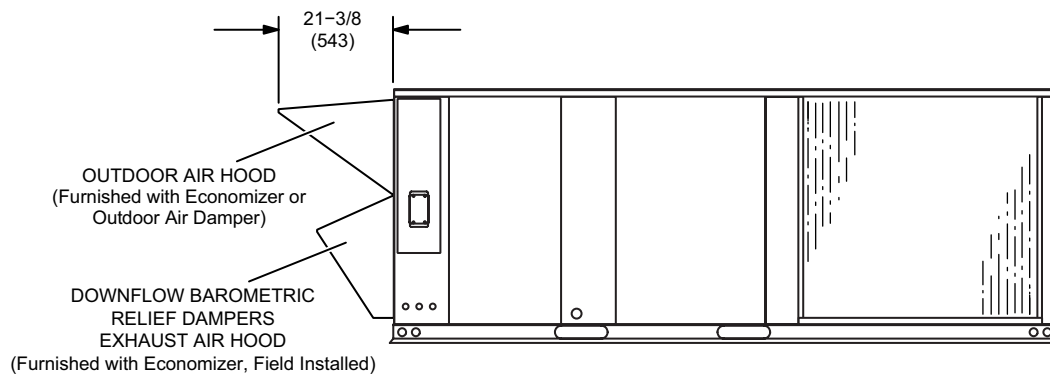

OPTIONAL HORIZONTAL ECONOMIZER APPLICATION

(with Optional Low Profile Horizontal Barometric Relief Dampers and Horizontal Discharge Kit)

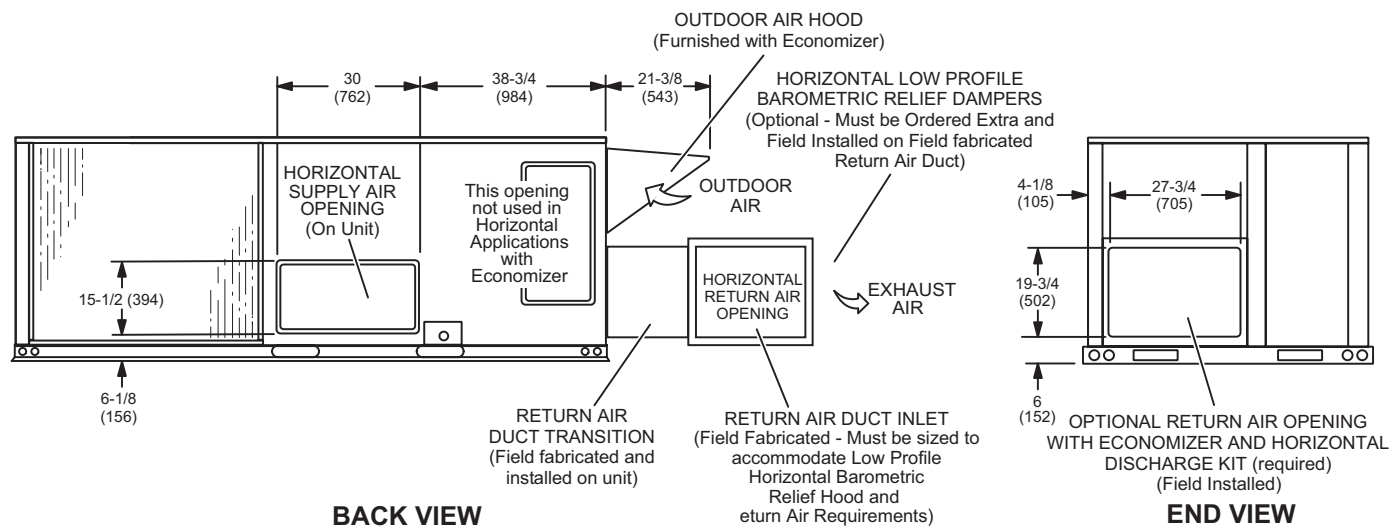
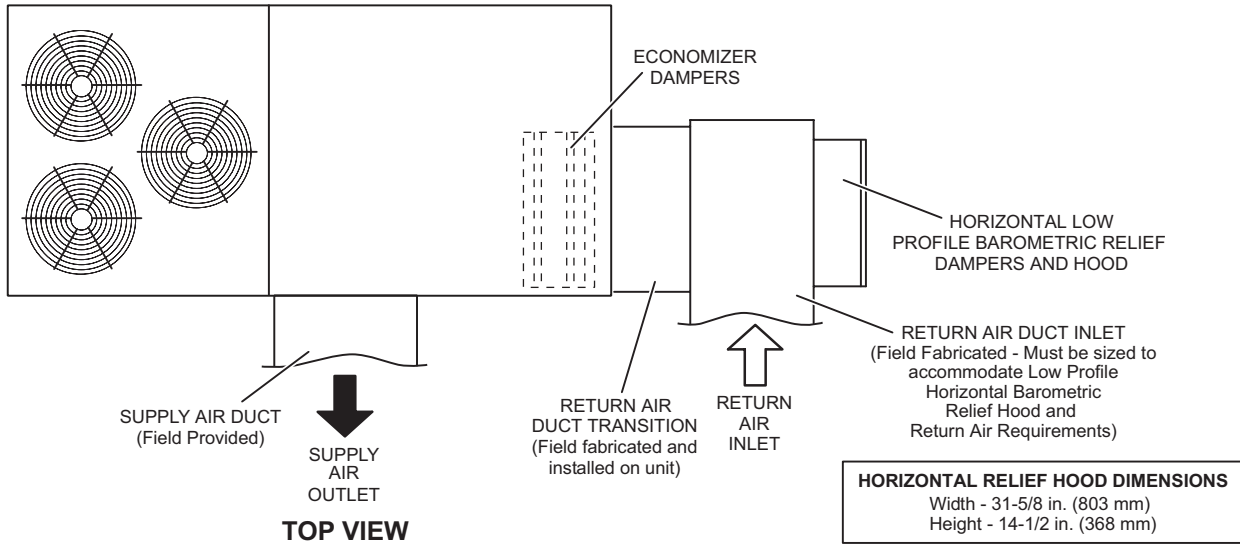

NOTE - Return Air Duct and Transition must be supported.

HORIZONTAL LOW PROFILE BAROMETRIC RELIEF DAMPERS

(Field installed in horizontal return air duct adjacent to unit)

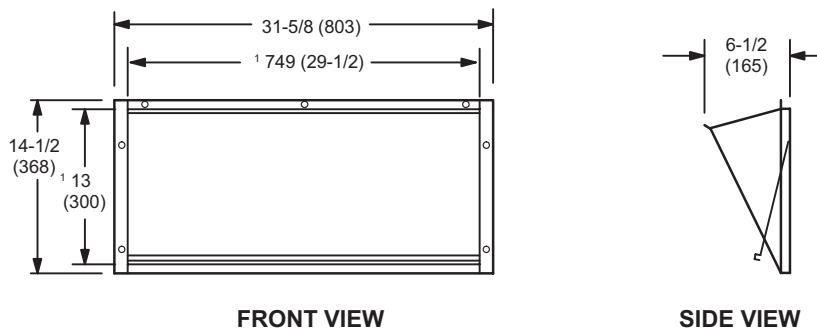

¹ NOTE - Opening size required in return air duct.

DIMENSIONS - ACCESSORIES

HYBRID ROOF CURBS - DOUBLE DUCT OPENING

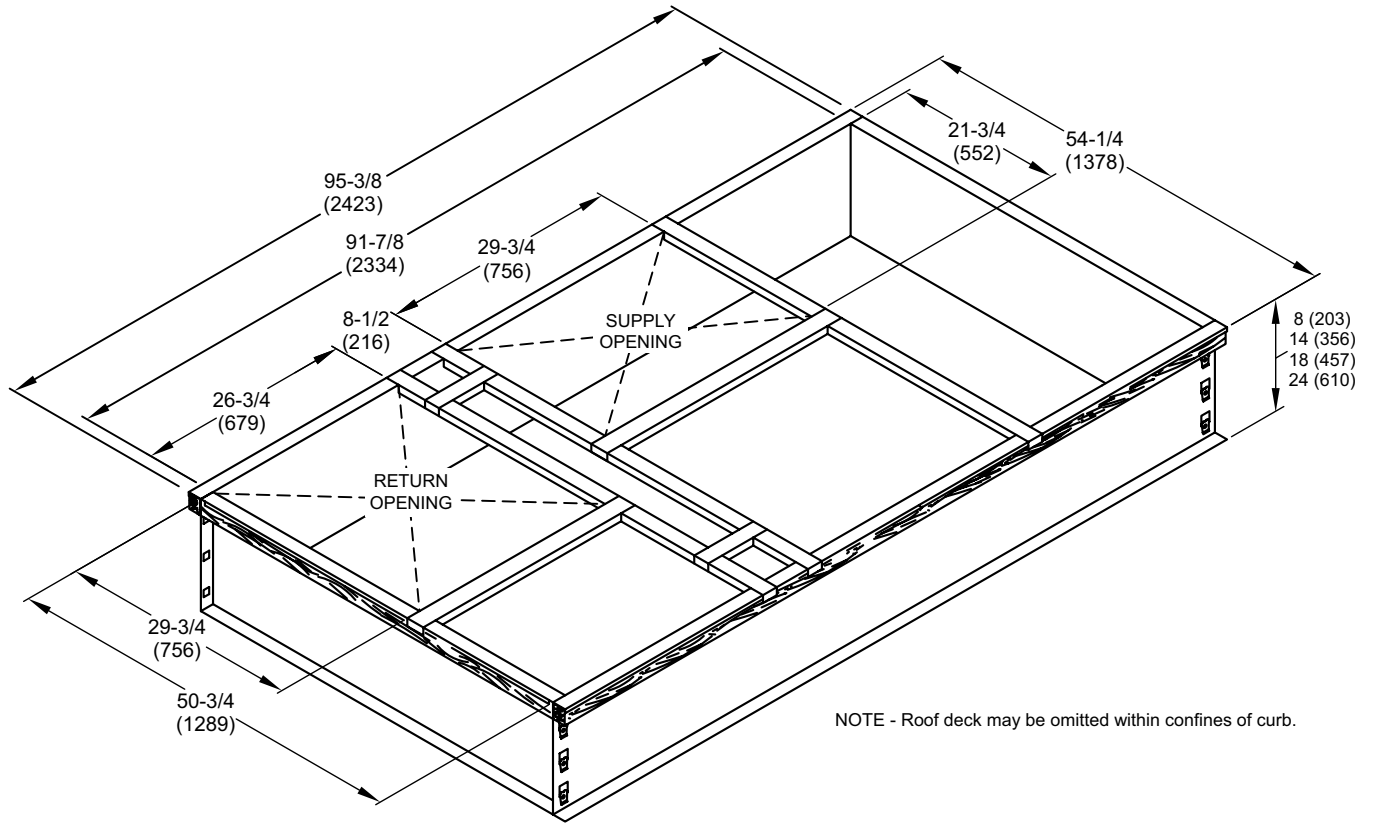

TYPICAL FLASHING DETAIL FOR ROOF CURB

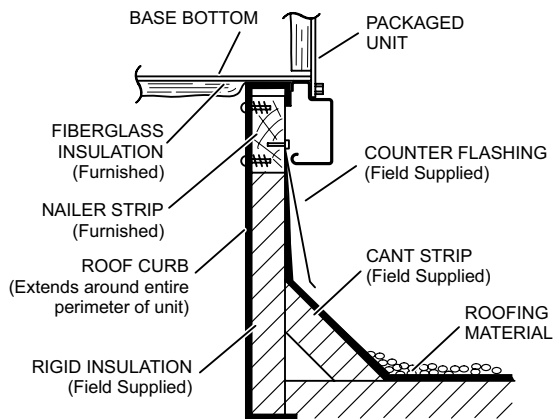

DETAIL ROOF CURB

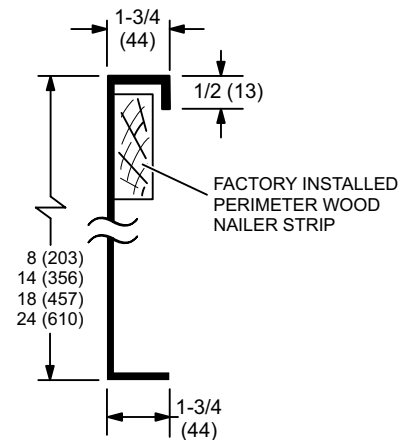

DIMENSIONS - ACCESSORIES

ADJUSTABLE PITCH CURBS - DOUBLE DUCT OPENING

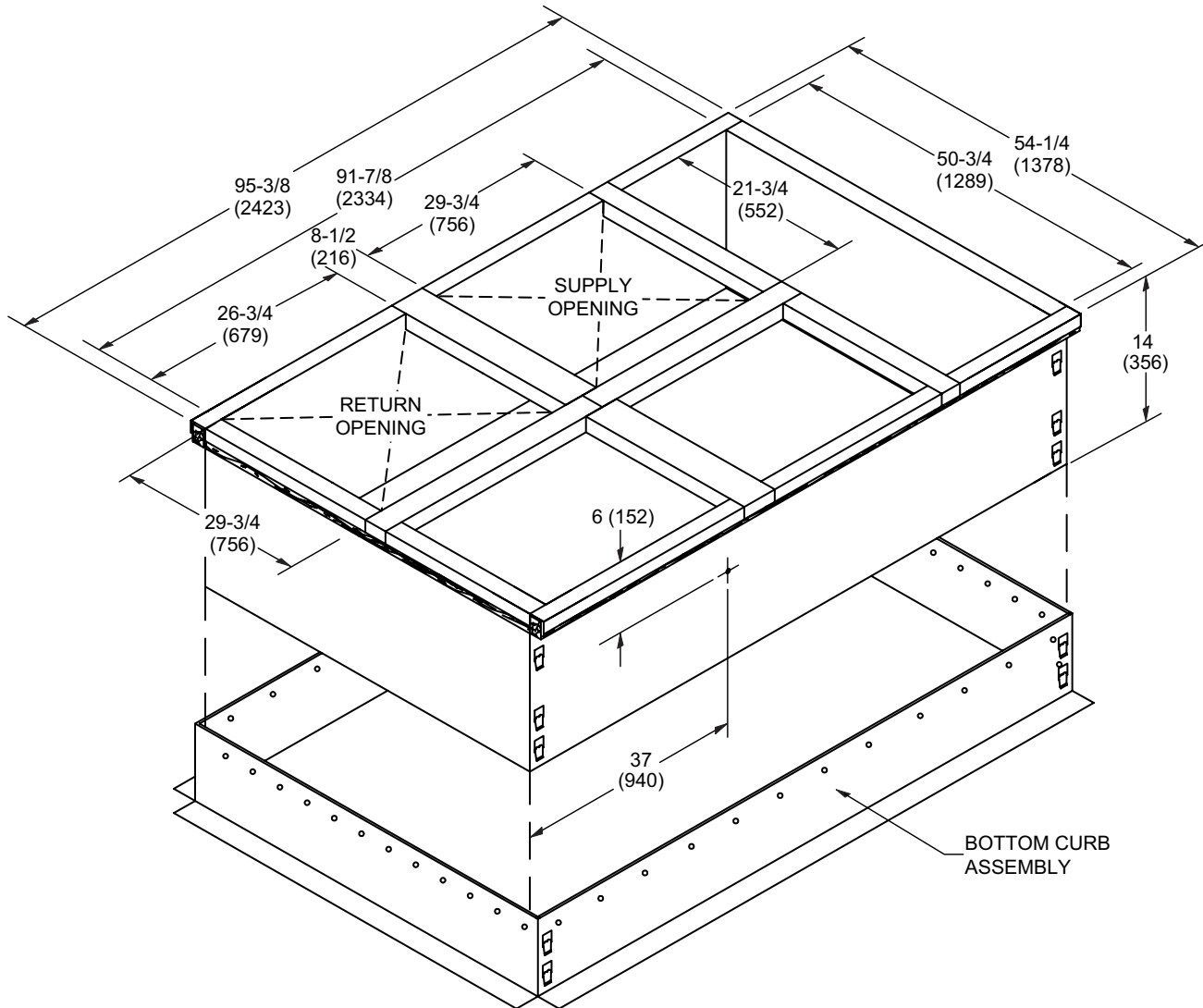

NOTE - Maximum slope pitch is 3/4 in. per 1 foot (19 mm per 305 mm) in any one direction.

TYPICAL FLASHING DETAIL FOR ROOF CURB

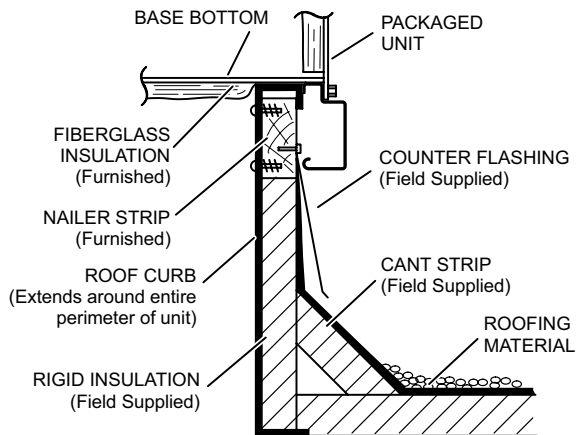

DETAIL ROOF CURB

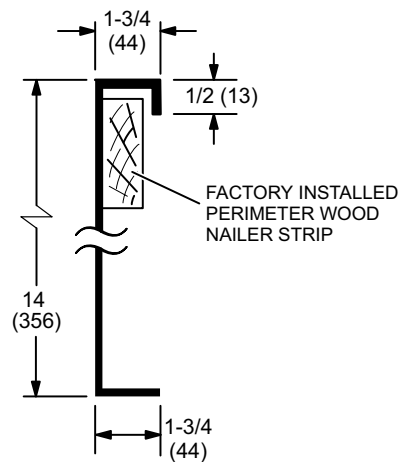

ROOF CURBS WITH SUPPLY & RETURN AIR TRANSITIONS FOR CEILING DIFFUSERS

C1DIFF30B-1 ROUND TRANSITIONS
(for 092 models)

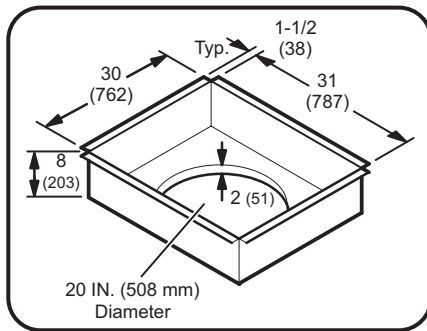

C1DIFF31B-1 & C1DIFF32B-1 RECTANGULAR TRANSITIONS
(for 102 thru 150 models)

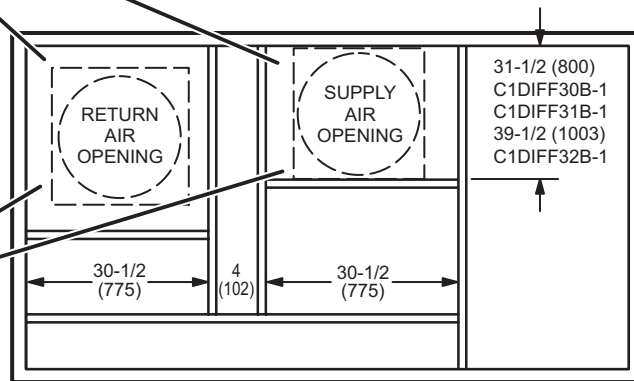
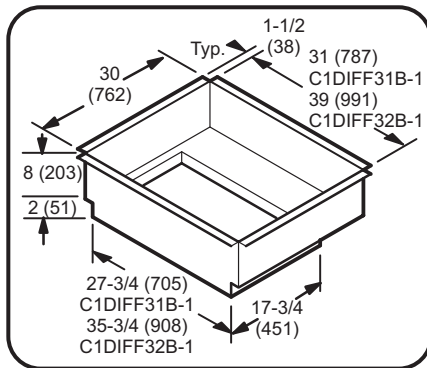

TOP VIEW

DIMENSIONS - ACCESSORIES

COMBINATION CEILING SUPPLY AND RETURN DIFFUSERS

STEP-DOWN CEILING DIFFUSER

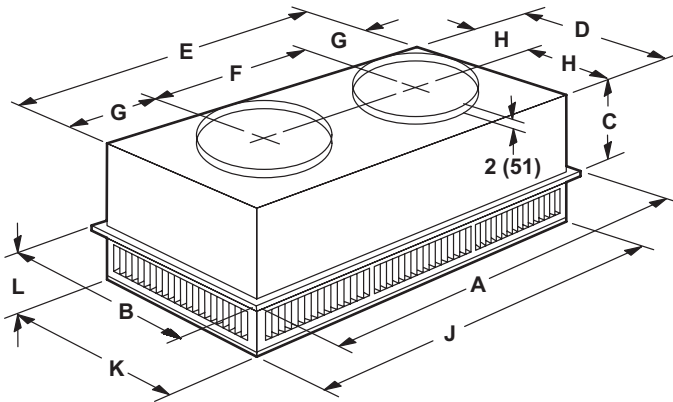

FLUSH CEILING DIFFUSER

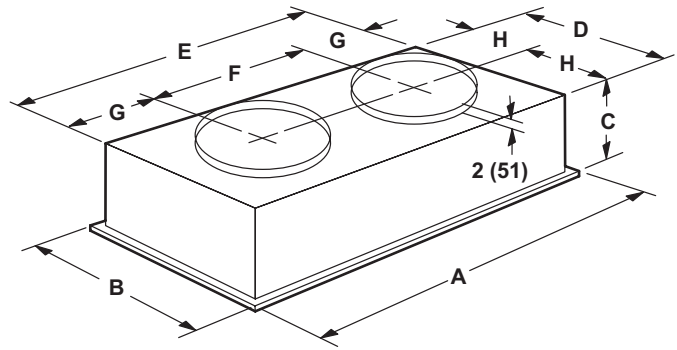

Model Number		RTD11-95S
A	in.	47-5/8
	mm	1159
B	in.	29-5/8
	mm	752
C	in.	14-3/8
	mm	365
D	in.	27-1/2
	mm	699
E	in.	45-1/2
	mm	1158
F	in.	22-1/2
	mm	572
G	in.	11-1/2
	mm	292
H	in.	13-3/4
	mm	349
J	in.	45-1/2
	mm	1156
K	in.	27-1/2
	mm	699
L	in.	8-1/8
	mm	206
Duct Size	in.	20 round
	mm	508 round

Model Number		FD11-95S
A	in.	47-5/8
	mm	1159
B	in.	29-5/8
	mm	752
C	in.	16-5/8
	mm	422
D	in.	27
	mm	686
E	in.	45
	mm	1143
F	in.	22-1/2
	mm	572
G	in.	11-1/4
	mm	286
H	in.	13-1/2
	mm	343
Duct Size	in.	20 round
	mm	508 round

DIMENSIONS - ACCESSORIES

COMBINATION CEILING SUPPLY AND RETURN DIFFUSERS STEP-DOWN CEILING DIFFUSER

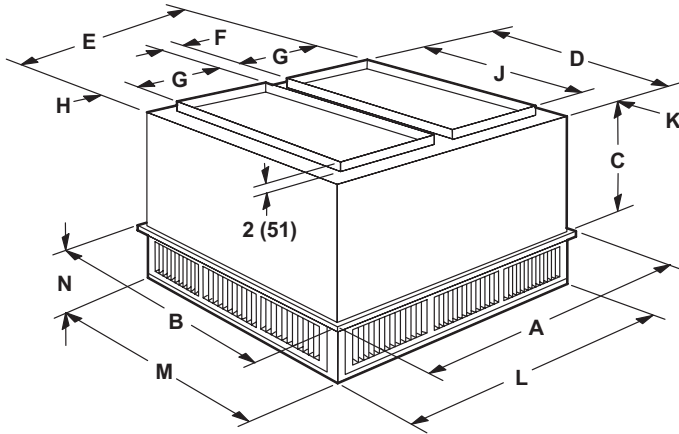

FLUSH CEILING DIFFUSER

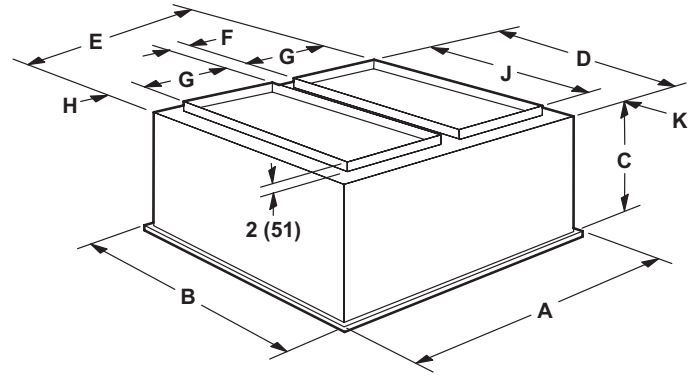

Model Number		RTD11-135S	RTD11-185S
A	in.	47-5/8	47-5/8
	mm	1210	1210
B	in.	35-5/8	47-5/8
	mm	905	1210
C	in.	20-5/8	24-5/8
	mm	524	625
D	in.	33-1/2	45-1/2
	mm	851	1156
E	in.	45-1/2	45-1/2
	mm	1156	1156
F	in.	4-1/2	4-1/2
	mm	114	114
G	in.	18	18
	mm	457	457
H	in.	2-1/2	2-1/2
	mm	64	64
J	in.	28	36
	mm	711	914
K	in.	2-3/4	4-3/4
	mm	70	121
L	in.	45-1/2	45-1/2
	mm	1156	1156
M	in.	33-1/2	45-1/2
	mm	851	1156
N	in.	9-1/8	10-1/8
	mm	232	257
Duct Size	in.	18 x 28	18 x 36
	mm	457 x 711	457 x 914

Model Number		FD11-135S	FD11-185S
A	in.	47-5/8	47-5/8
	mm	1210	1210
B	in.	35-5/8	47-5/8
	mm	905	1210
C	in.	23-1/4	29-1/4
	mm	591	743
D	in.	33	45
	mm	838	1143
E	in.	45	45
	mm	1143	1143
F	in.	4-1/2	4-1/2
	mm	114	114
G	in.	18	18
	mm	457	457
H	in.	2-1/4	2-1/4
	mm	57	57
J	in.	28	36
	mm	711	914
K	in.	2-1/2	4-1/2
	mm	64	114
Duct Size	in.	18 x 28	18 x 36
	mm	457 x 711	457 x 914

REVISIONS

Sections	Description of Change
Options/Accessories	Added step-down transformers for UVC lights. Catalog numbers revised for: Blower Proving Switch Condensate Drain Trap Discharge Air Temperature Switch Economizers Drain Pan Overflow Switch Single Enthalpy

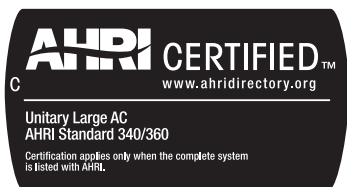

Visit us at www.lennox.com

For the latest technical information, www.lennoxcommercial.com

Contact us at 1-800-4-LENNOX

NOTE - Due to Lennox' ongoing commitment to quality, Specifications, Ratings and Dimensions subject to change without notice and without incurring liability. Improper installation, adjustment, alteration, service or maintenance can cause property damage or personal injury. Installation and service must be performed by a qualified installer and servicing agency.

©2021 Lennox Industries, Inc.