



**COMMERCIAL**  
**PRODUCT SPECIFICATIONS**

Bulletin No. 210558  
 October 2020  
 Supersedes August 2020



SMART WIRE™ SYSTEM



**13 to 25 Tons**  
**Net Cooling Capacity - 148,000 to 270,000 Btuh**  
**Optional Electric Heat - 15 to 90 kW**

**MODEL NUMBER IDENTIFICATION**

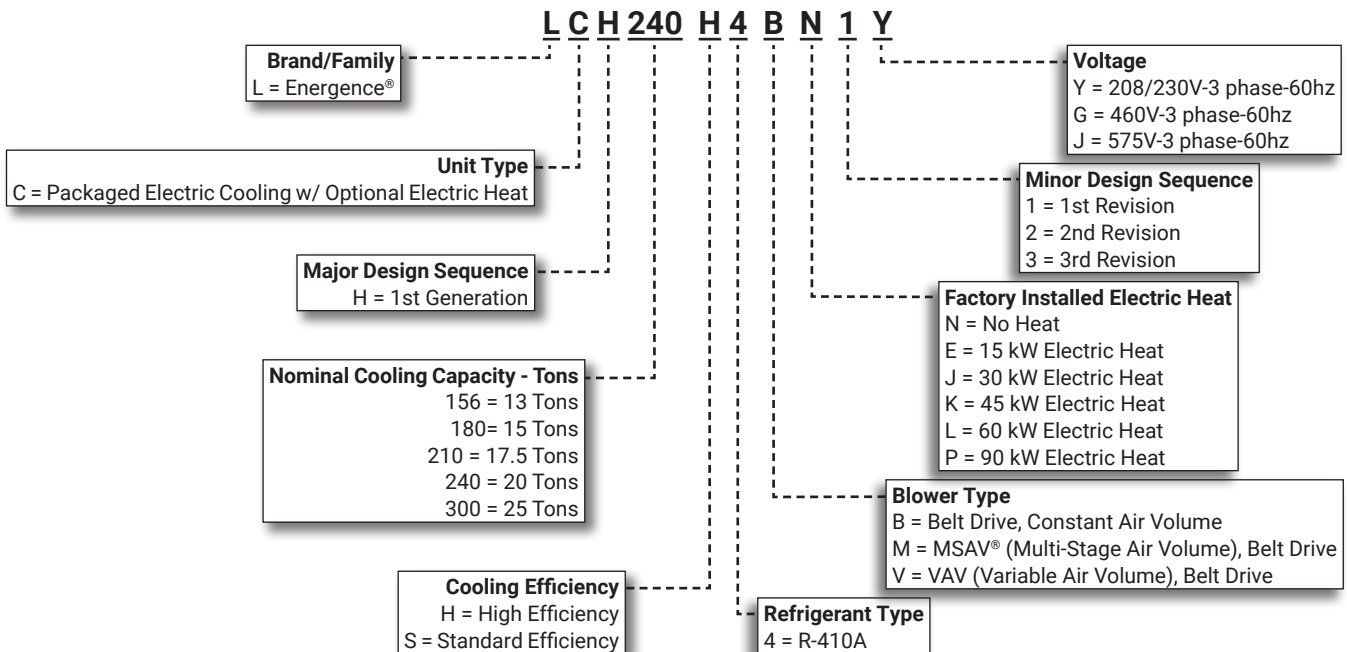

## FEATURE HIGHLIGHTS

Lennox' Energence® packaged rooftop unit product line was created to save energy with intelligence by offering some of the highest energy efficiency ratings available with a powerful, easy to use unit controller. This makes Energence rooftop units perfect for business owners looking for an HVAC product with the lowest total cost of ownership.

1. Scroll Compressors
2. Thermal Expansion Valves
3. Filter/Driers
4. Lennox' Environ™ Coil System
5. Outdoor Coil Fan Motors
6. Heavy Gauge Steel Cabinet
7. Hinged Access Panels
8. Constant or Multi-Stage Air Volume (MSAV®) Blower
9. Variable Frequency Drive (VFD)
10. Disconnect Switch (option)
11. Electric Heat (option)
12. Air Filters
13. Prodigy® Control System
14. Economizer (option)
15. Downflow Barometric Relief Dampers (option)
16. Power Exhaust Fans (option)

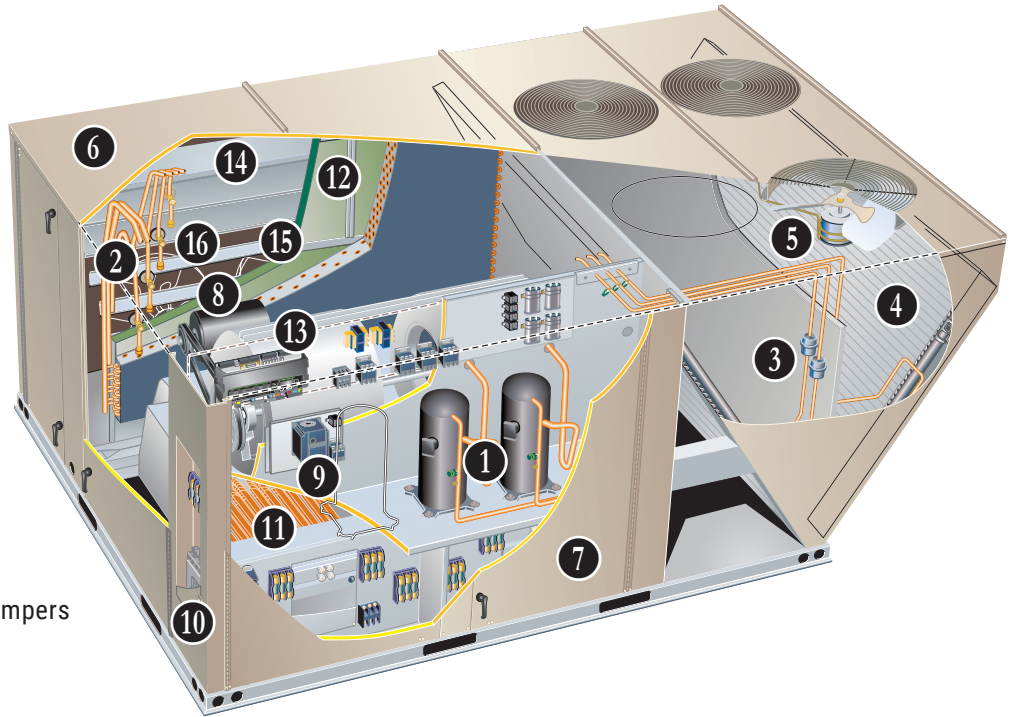

## CONTENTS

Approvals And Warranty . . . . .	3
Blower Data . . . . .	44
Control System . . . . .	8
Dehumidification System Option . . . . .	12
Dehumidification System Ratings . . . . .	41
Dimensions - Accessories . . . . .	59
Dimensions - Unit . . . . .	56
Electrical Accessories - Disconnects . . . . .	52
Electrical/Electric Heat Data . . . . .	47
Electric Heat Capacities . . . . .	54
Features And Benefits . . . . .	3
Model Number Identification . . . . .	1
Options / Accessories . . . . .	24
Outdoor Sound Data . . . . .	54
Ratings . . . . .	32
Sequence Of Operation . . . . .	16
Specifications . . . . .	28
Unit Clearances . . . . .	54
Weight Data . . . . .	55

## APPROVALS AND WARRANTY

### APPROVALS

- AHRI Standard 340/360 certified
- ETL and CSA listed
- CSA certified energy ratings
- Unit and components ETL, NEC and CEC bonded for grounding to meet safety standards for servicing
- All models are ASHRAE 90.1-2010 energy efficiency compliant and meet or exceed requirements of Section 6.8
- All models meet DOE 2018 energy efficiency standards
- MSAV models meet California Code of Regulations, Title 24 and ASHRAE 90.1-2010 Section 6.4.3.10 requirements for staged airflow
- ENERGY STAR® certified
- ISO 9001 Registered Manufacturing Quality System

### WARRANTY

- Compressors - Limited five years
- Lennox' Environ™ Coil System - Limited three years
- Prodigy® 2.0 Unit Controller - Limited three years
- Optional High Performance Economizers - Limited five years
- All other covered components - Limited one year

## FEATURES AND BENEFITS

### COOLING SYSTEM

- Designed to maximize sensible and latent cooling performance at design conditions
- System can operate from 0°F to 125°F without any additional controls

#### R-410A Refrigerant

- Non-chlorine based
- Ozone friendly

#### 1 Scroll Compressors

- Scroll compressors on all models for high performance, reliability and quiet operation
- Resiliently mounted on rubber grommets for quiet operation

#### Compressor Crankcase Heaters

- Protects against refrigerant migration that can occur during low ambient operation

#### 2 Thermal Expansion Valves

- Assures optimal performance throughout the application range
- Removable element head

#### 3 Filter/Driers

- High capacity filter/drier protects the system from dirt and moisture

#### High Pressure Switches

- Protects the compressor from overload conditions such as dirty condenser coils, blocked refrigerant flow, or loss of outdoor fan operation

#### Low Pressure Switches

- Protects the compressors from low pressure conditions such as low refrigerant charge, or low/no airflow

#### Freezestats

- Protects the evaporator coil from damaging ice build-up due to conditions such as low/no airflow, or low refrigerant charge

#### 4 Condenser Coil - Lennox' Environ™ Coil System

- Lightweight, all aluminum brazed fin construction
- Constructed of three components
  - A flat extrusion tube
  - Fins in-between the flat extrusion tube
  - Two refrigerant manifolds

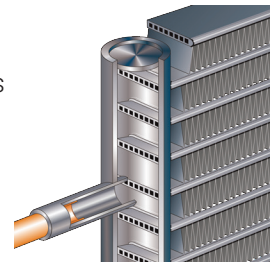

#### Environ™ Coil System Features:

- Improved heat transfer performance due to high primary surface area (flat tubes) versus secondary surface (fins)
- Smaller internal volume (reduced refrigerant charge)
- High durability
- All aluminum construction
- Fewer brazed joints
- Compact design
- Reduced unit weight
- Easy maintenance/cleaning
- Face split design
- Mounting brackets with rubber inserts
- Angled cabinet design protects coil from damage

## FEATURES AND BENEFITS

### COOLING SYSTEM (continued)

#### Evaporator Coil

- Copper tube construction
- Enhanced rippled-edge aluminum fins
- Flared shoulder tubing connections
- Silver soldered construction
- Factory leak tested
- Cross row circuiting with rifled tubing

**NOTE** - Constant air volume (CAV) and MSAV® (Multi-Stage Air Volume) models have face-split evaporator coils designed to keep condensate water off of an inactive part of the coil so the condensate will not re-enter the air stream. Variable air volume (VAV) models have row-split, intertwined evaporator coils.

#### Condensate Drain Pan

- Plastic pan, sloped to meet drainage requirements per ASHRAE 62.1
- Side or bottom drain connections

### 5 Outdoor Coil Fan Motors

- Thermal overload protected
- Totally enclosed
- Permanently lubricated ball bearings
- Shaft up
- Wire basket mount

#### Outdoor Coil Fans

- PVC coated fan guard furnished

### Required Selections

#### Cooling Capacity

- Specify nominal cooling capacity

### Options/Accessories

#### Factory Installed

#### Conventional Fin/Tube Condenser Coil (replaces Environ™ Coil System)

- Copper tube construction
- Enhanced rippled-edge aluminum fins
- Flared shoulder tubing connections
- Silver soldered construction

**NOTE** - Not available for VAV equipped models.

#### Discharge Air Temperature Sensor

- Sensor sends information to the unit controller to cycle up to 2 stages of heating or 4 stages of cooling to maintain the discharge air setpoints for heating or cooling
- Optional for CAV units (single zone or bypass zoning control)

**NOTE** - Automatically furnished with all Variable Air Volume (VAV) units. Sensor is shipped with the unit for remote field installation in the supply duct

#### Service Valves

- Fully serviceable brass valves installed in discharge & liquid lines

**NOTE** - Not available for units equipped with Environ™ Coil System or Humiditrol® Dehumidification option.

### Factory or Field Installed

#### Condensate Drain Trap

- Field installed only
- May be factory enclosed to ship with unit
- Available in copper or PVC

#### Drain Pan Overflow Switch

- Monitors condensate level in drain pan
- Shuts down unit if drain becomes clogged

### CABINET

### 6 Construction

- Heavy-gauge steel panels
- Full perimeter heavy-gauge galvanized steel base rail
- Base rails have rigging holes
- Three sides of the base rail have forklift slots
- Raised edges around duct and power entry openings in the bottom of the unit for water protection

#### Airflow Choice

- Units are shipped in downflow (vertical) return air flow configuration

**NOTE** - Units can be field converted to horizontal air flow with optional Horizontal Return Air Panel Kit and Horizontal Roof Curb.

#### Power Entry

- Electrical lines can be brought through the unit base or through horizontal access knock-outs

#### Exterior Panels

- Constructed of heavy-gauge, galvanized steel
- Two-layer enamel paint finish

#### Insulation

- Fully insulated with non-hygroscopic fiberglass insulation (conditioned areas)
- Unit base is fully insulated
- Base insulation serves as an air seal to the roof curb, eliminating the need to add a seal during installation

### 7 Hinged Access Panels

- Filter section
- Blower section
- Heating section
- Compressor/controls section
- Panel seals and quarter-turn latching handles provide a tight air and water seal

## FEATURES AND BENEFITS

### CABINET (continued)

#### Required Selections

#### Airflow Configuration

- Specify downflow or horizontal

#### Options/Accessories

### Factory Installed

#### Corrosion Protection

- Completely flexible immersed coating
- Electrodeposited dry film process
- AST ElectroFin E-Coat
- Meets Mil Spec MIL-P-53084, ASTM B117 Standard Method Salt Spray Testing
- Indoor Corrosion Protection:
  - Coated coil
  - Coated reheat coil (Humiditrol®)
  - Painted blower housing
  - Painted base
- Outdoor Corrosion Protection:
  - Coated coil
  - Painted outdoor base

### Field Installed

#### Combination Coil/Hail Guards

- Heavy gauge steel frame
- Painted to match cabinet
- Expanded metal mesh protects outdoor coil

#### Horizontal Return Air Panel Kit

- Required for horizontal applications with Horizontal Roof Curb
- Contains panel with return air opening for field replacement of existing unit panel and panel to cover bottom return air opening in unit
- See dimension drawings

### BLOWER

- A wide selection of supply air blower options are available to meet a variety of airflow requirements

#### Motor

- Overload protected
- Ball bearings
- Belt drive motors are offered on all models and are available in several different sizes to maximize air performance

**NOTE** - All blower motors 5 hp and above meet minimum energy efficiency standards in accordance with the Energy Independence and Security Act (EISA) of 2007

#### Supply Air Blower

- Forward curved blades
- Double inlet
- Blower wheel statically and dynamically balanced

- Ball bearings
- Adjustable pulley (allows speed change)
- Blower assembly slides out of unit for servicing
- Grease fittings furnished

#### Supply Static Pressure Transducer (156/180/240 VAV Models Only)

- Sends information to the Prodigy® 2.0 unit controller to control VFD blower speed
- Shipped with the unit for remote field installation in the supply duct

#### Required Selections

### 8 Select Constant Air Volume (CAV), Variable Air Volume (VAV) or MSAV® (Multi-Stage Air Volume)

- Constant Air Volume (CAV) models supply a constant volume of air
- Variable Air Volume (VAV) (156/180/240 Models Only) variable frequency drive (VFD) varies the air volume to maintain a constant duct static pressure
- MSAV (Multi-Stage Air Volume) models stage the amount of airflow according to compressor stages, heating demand, ventilation demand or smoke alarm

**NOTE** - Units with the MSAV® supply air blower option have the same face split indoor coils as units with the CAV supply air blower option. Part load airflow in cooling mode on MSAV® units should not be set below 220 cfm/nominal full load ton to reduce the risk of evaporator coil freeze-up.

- Utilizes a Variable Frequency Drive (VFD) to stage the supply blower airflow
- VFD alters the frequency and voltage of the power supply to the blower to control blower speed
- The amount of airflow for each stage can be set according to a parameter in the Prodigy® 2.0 unit controller
- Unit is shipped from the factory with preset airflow
- MSAV® can be ordered with or without an Electronic Bypass Control
- If equipped with the bypass control the MSAV® features manual (default) or automatic electronic bypass control of the VFD
- In case of a VFD malfunction, a VFD alarm is generated by the Prodigy® 2.0 unit controller
- VFD can be manually bypassed to continue unit operation at full blower speed
- Or the unit controller can be set to automatically switch to full blower speed if a VFD alarm is generated
- VFD has an operational range of 0 to 125°F outdoor air ambient temperature
- Lower operating costs are obtained when the blower is operated on lower speeds

#### Ordering Information

- Specify motor horsepower and drive kit number when base unit is ordered



## FEATURES AND BENEFITS

### **BLOWER (continued)**

#### Options/Accessories

### **Factory Installed**

#### Blower Belt Auto-Tensioner

- Provides proper tension to belt drive blower belt without the need for regular adjustments
- Maintains airflow and proper performance

### **ELECTRICAL**

**NOTE** - All units include terminal block and fuse block in power entry junction box for single power entry application.

#### SmartWire™ System

- Keyed and color-coded wiring connectors prevent miswiring
- Wire coloring scheme is standardized across all models
- Each connection is intuitively labeled to make troubleshooting and servicing quick and easy

#### Electrical Plugs

- Positive connection electrical plugs connect common accessories or maintenance parts for easy removal or installation

#### Required Selections

#### Voltage Choice

- Specify when ordering base unit

#### Options/Accessories

### **Factory Installed**

#### Circuit Breakers

- HACR type
- Overload and short circuit protection
- Factory wired and mounted in the power entry panel
- Current sensitive and temperature activated
- Manual reset

#### SCR (Silicon Controlled Rectifier) Electric Heat Control

- Modulates small, precise increments of power to the electric heat load eliminating temperature fluctuations associated with mechanical controls
- Almost instantaneous operation with no moving parts
- Zero-Cross (fast cycling) feature improves electric heater life with less contraction and expansion of the heating elements
- The SCR operates when there is no call for heat from the building control system or thermostat
- SCR air tempering is controlled by a secondary thermostat and remote duct sensor (ordered separately)
- A call for heat overrides the SCR and modulates the SCR to 100% heat output
- A call for cooling overrides the SCR

**NOTE** - SCR option is not available with 45 kW, 60 kW and 90kW electric heat (208/230V) models.

**NOTE** - Blower Proving Switch is required and must be ordered separately for factory installation. See Controls in the Options/Accessories table.

**NOTE** - Available for use with conventional thermostat controls or Novar® control systems only.

#### Short-Circuit Current Rating (SCCR)

- Higher short-circuit protection up to 100kA

**NOTE** - Disconnect Switch not available with higher SCCR option. Short-Circuit Current Rating option not available on field installed electric heat or 90kW electric heat (208/240V) models.

#### Phase/Voltage Detection (Optional for CAV Models Only)

- Monitors power supply to assure phase is correct at unit start-up
- If phase is incorrect, the unit will not start and an alarm code is reported to the unit controller
- Protects unit from being started with incorrect phasing which could lead to issues such as compressors running backwards
- Voltage detection monitors power supply voltage to assure proper voltage
- If voltage is not correct (over/under voltage conditions) the unit will not start and an alarm code is reported to the unit controller

**NOTE** - Phase/voltage detection is furnished when the MSAV (Multi-Stage Air Volume) option is ordered.

### **Factory or Field Installed**

#### 9 Disconnect Switch

- Accessible outside of unit
- Spring loaded weatherproof cover furnished

#### 10 Electric Heat

- Helix wound nichrome elements
- Individual element limit controls
- Wiring harness
- Unit fuse block
- See Options/Accessories tables for ordering information

#### 11 GFI Service Outlets (2)

- 115V ground fault circuit interrupter (GFCI) type
- Available non-powered, field-wired or factory-wired and powered

### **Field Installed**

#### GFI Weatherproof Cover

- Single-gang cover
- Heavy-duty UV-resistant polycarbonate case construction
- Hinged base cover with gasket

## FEATURES AND BENEFITS

### INDOOR AIR QUALITY

#### 12 Air Filters

- Disposable 2 inch filters furnished as standard

#### Options/Accessories

#### Factory or Field Installed

##### Healthy Climate® High Efficiency Air Filters

- Disposable MERV 8 or MERV 13 (Minimum Efficiency Reporting Value based on ASHRAE 52.2) efficiency 2-inch pleated filters

##### Replacement Filter Media Kit With Frame

- Replaces existing pleated filter media
- Includes washable metal mesh screen and metal frame with clip for holding replaceable non-pleated filter

#### Field Installed

##### Healthy Climate® UVC Germicidal Light Kit

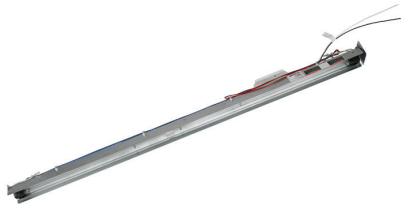

- Germicidal lamps emit ultra-violet (UV-C) energy, which has been proven to be effective in reducing microbes such as viruses, bacteria, yeasts, and molds
- This process either destroys the organism or controls its ability to reproduce
- UV-C energy greatly reduces the growth and proliferation of mold and other bioaerosols (bacteria and viruses) on illuminated surfaces (particularly coil and drain pan)
- Field installed in the blower/evaporator coil section
- All necessary hardware for installation is included.
- Lamps operate on 110/230V, 1 phase power supply

**NOTE** - Step-down transformer must be field supplied when used with 460V and 575V rooftop units. Step-down transformer is furnished with lamps when factory installed.

- Approved by ETL

##### Indoor Air Quality (CO<sub>2</sub>) Sensors

- Monitors CO<sub>2</sub> levels, reports to the Prodigy® 2.0 unit controller which adjusts economizer dampers as needed

## CONTROL SYSTEM

### PRODIGY® CONTROL SYSTEM



**13** The Prodigy 2.0 unit controller is a microprocessor-based controller that provides flexible control of all unit functions.

#### Features:

- LCD Display
- Easy to read menu (4 lines x 20 character display)
- Buttons for menu navigation during setup and diagnostic
- Menu navigation LEDs for Data, Setup, Service, Settings
- Main Menu and Help Buttons for quick navigation to home screen and built-in help functions
- Scroll, Value Adjustment Select and Save Buttons
- Setup menu insures proper installation and simplified setup of the rooftop unit
- Profile setup copies key settings between units with the same configuration to reduce setup time
- USB port allows a technician to download and transfer unit information to help verify service was performed
- USB software updates on the Prodigy Control System enhance functionality without the need to change components
- Unit Controller Software
- Unit self-test verifies individual critical component and system performance
- Economizer test function assures economizer is operating correctly
- Time Clock with Run-Time Information

#### Built-In Functions Include:

- Adjustable Blower On/Off Delay
- Built-in Control Parameter Defaults
- Compressor Time-Off Delay
- DDC Compatible
- Dirty Filter Switch Input
- Discharge Air Temperature Control
- Display/Sensor Readout
- Economizer Control Options (See Economizer / Exhaust Air / Outdoor Air sections)
- Fresh Air Tempering
- Over 100 diagnostic and status messages in English
- Exhaust Fan Control Modes for fresh air damper position
- Permanent Diagnostic Code Storage
- Field Adjustable Control Parameters (Over 200 settings)
- Indoor Air Quality Input (Demand Control Ventilation)
- Low Ambient Controls for cooling operation down to 0°F
- Gas Valve Time Delay Between First and Second Stage

- Minimum Compressor Run Time
- Network Capable (Can be daisy chained to other units or controls)
- Night Setback Mode
- Return Air Temperature Limit Control
- Safety Switch Input allows Controller to respond to a external safety switch trip
- Service Relay Output
- Smoke Alarm Mode has four choices (unit off, positive pressure, negative pressure, purge)
- Up to 2 heat/2 cool (standard Prodigy unit controller thermostat input)
- Up to 3 cool with additional relay
- Up to 4 cool with room sensor or network operation
- "Strike Three" Protection
- Gas Reheat Control allows simultaneous heating and cooling operation for humidity control of process air applications such as supermarkets
- On Demand Dehumidification monitors and controls condenser hot gas reheat operation with Humiditrol® dehumidification option
- Thermostat Bounce Delay
- Warm Up Mode Delay
- LED Indicators
- PC Interface connects the Prodigy 2.0 unit controller to a PC with the Lennox Unit Controller Software
- Room Sensor Operation controls temperature

**NOTE** - Prodigy Control System features shown vary with the type of rooftop unit the control is installed in.

**NOTE** - See separate Prodigy Control System Product Specifications Bulletin for additional information.



## CONTROL SYSTEM

### **PRODIGY® CONTROL SYSTEM (continued)**

#### Control Options

#### **Factory or Field Installed**

##### **Blower Proving Switch**

- Monitors blower operation, shuts down unit if blower fails

##### **Dirty Filter Switch**

- Senses static pressure increase indicating dirty filter condition

##### **Fresh Air Tempering**

- Used in applications with high outside air requirements
- Controller energizes the first stage heat as needed to maintain a minimum supply air temperature for comfort, regardless of the thermostat demand
- When ordered as a factory option, sensor ships with the unit for field installation

##### **Smoke Detector**

- Photoelectric type
- Installed in supply air section, return air section or both sections
- Available with power board and single sensor (supply or return) or power board and two sensors (supply and return)
- Power board located in unit control compartment

##### **Interoperability via BACnet® or LonTalk® Protocols**

- Communication compatible with third-party automation systems that support the BACnet Application Specific Controller device profile, LonMark® Space Comfort Controller functional profile, or LonMark Discharge Air Controller functional profile

#### **Commercial Control Systems**

##### **L Connection® Network Control System**

- Complete building automation control system for single or multi-zone applications
- Options include local interface, software for local or remote communication, and hardware for networking other control functions
- See L Connection Network Control System Product Specifications Bulletin for details

##### **After-Market DDC**

- Novar® Unit Controller and options

##### **Thermostats**

- Control system and thermostat options
- After-Market unit controller options

#### **Field Installed**

##### **General Purpose Control Kit**

- Plug-in control provides additional analog and digital inputs/outputs for field installed options

##### **Humidity Sensor Kit**

- Humidity sensor required with factory installed Humiditrol® dehumidification option or Supermarket reheat field selectable option

## OPTIONS / ACCESSORIES

### **ECONOMIZER**

- Economizer operation is set and controlled by the Prodigy 2.0 unit controller
- Simple plug-in connections from economizer to unit controller for easy installation
- All Emergence rooftop units are equipped with factory installed CEC Title 24 approved sensors for outside, return and discharge air temperature monitoring

**NOTE** - Optional sensors may be used instead of unit sensors to determine whether outdoor air is suitable for free cooling. See Options/Accessories table.

#### **Factory or Field Installed**

##### **14 High Performance Economizer**

- Approved for California Title 24 building standards
- Low leakage dampers are Air Movement and Control Association International (AMCA) Class 1A Certified - Maximum 3 CFM per sq. ft. leakage at 1 in. w.g.
- ASHRAE 90.1-2010 compliant
- Outdoor Air Hood with mist elimination is included when economizer is factory installed and is furnished with economizer when ordered for field installation
- Gear-driven action
- High torque 24-volt fully-modulating spring return damper motor
- Return air and outdoor air dampers
- Plug-in connections to unit
- Stainless steel bearings
- Enhanced neoprene blade edge seals
- Flexible stainless steel jamb seals

**NOTE** - High Performance Economizers are not approved for use with enthalpy controls in Title 24 applications.

**NOTE** - The Free Cooling setpoint for Title 24 applications must be set based on the Climate Zone where the system is installed. See Section 140.4 "Prescriptive Requirements for Space Conditioning Systems" of the California Energy Commission's 2013 Building Energy Efficiency Standards.

**NOTE** - Refer to Installation Instructions for complete setup information.

## OPTIONS / ACCESSORIES

### ECONOMIZER (continued)

#### Differential Sensible Control

- Factory setting
- Uses outdoor air and return air sensors that are furnished with the unit
- The Prodigy® 2.0 unit controller compares outdoor air temperature with return air
- When the outdoor air is below the configured setpoint and cooler than return air, the controller activates the economizer

**NOTE** - Differential Sensible Control can be configured in the field to provide Offset Differential Sensible Control or Single Sensible Control.

**NOTE** - In Offset Differential Sensible Control mode, the economizer is enabled if the temperature differential (offset) between outdoor air and return air reaches the configured setpoint. In Single Sensible Control mode, the economizer is enabled when outdoor air temperature falls below the configured setpoint.

#### Global Control

- The unit controller communicates with a DDC system with one global sensor (enthalpy or sensible)
- Determines whether outside air is suitable for free cooling on all units connected to the control system
- Sensor must be field provided

### Factory or Field Installed

#### Single Enthalpy Temperature Control (Not for Title 24)

- Outdoor air enthalpy sensor enables Economizer if the outdoor enthalpy is less than the setpoint of the control

#### Differential Enthalpy Control (Not for Title 24)

- Order two Single Enthalpy Controls
- One is field installed in the return air section
- One is installed in the outdoor air section
- Allows the economizer control to select between outdoor air or return air, whichever has lower enthalpy

### Field Installed

#### Outdoor Air CFM Control

- Maintains constant outdoor air volume levels on the supply air fan and varying unit airflows
- Velocity sensor located in the rooftop unit outdoor air section, the Prodigy® 2.0 unit controller changes the economizer position to help minimize the effect of supply fan speed changes on outdoor air volume levels
- Setpoint for outdoor air volume is established by field testing

**NOTE** - Not available with Demand Control Ventilation (CO<sub>2</sub> Sensor) or Building Pressure Control.

#### Building Pressure Control

- Maintains constant building pressure level
- Includes a static pressure transducer and outdoor static pressure assembly
- Using differential pressure information between the outdoor air and the building air, the Prodigy® 2.0 unit controller changes the economizer position to help maintain a constant building pressure

**NOTE** - Not available with Demand Control Ventilation (CO<sub>2</sub> Sensor) or Outdoor Air CFM Control.

### EXHAUST

#### Factory or Field Installed

#### **15** Downflow Barometric Relief Dampers

- Allow relief of excess air
- Aluminum blade dampers prevent blow back and outdoor air infiltration during off cycle
- Exhaust hood is factory installed when dampers are factory installed with economizer
- Exhaust hood is furnished with dampers when ordered for field installation
- Bird screen furnished

#### **16** Power Exhaust Fans

- Install internal to unit for downflow applications only with economizer option
- Provides exhaust air pressure relief
- Interlocked to run when supply air blower is operating
- Fans run when outdoor air dampers are 50% open (adjustable)
- Motor is overload protected
- Dual propeller type fans are 20 in. diameter
- Five blades
- Two 1/3 hp motors

**NOTE** - Requires Economizer with furnished Outdoor Air Hood and Downflow Barometric Relief Dampers.

**NOTE** - MSAV® (Multi-Stage Air Volume) and VAV (Variable Air Volume) models are equipped with 2-stage power exhaust fans. Power exhaust operates in 1st stage (one fan) up to 70% of supply air blower speed. Both exhaust fans operate in 2nd stage when supply air blower speed is above 70% (adjustable) of full speed.

## OPTIONS / ACCESSORIES

### **EXHAUST (continued)**

#### **Field Installed**

##### **Horizontal Barometric Relief Dampers**

- For use when unit is configured for horizontal applications requiring an economizer
- Allows relief of excess air
- Aluminum blade dampers prevent blow back and outdoor air infiltration during off cycle
- Field installed in return air duct
- Bird screen and hood furnished

#### **OUTDOOR AIR**

#### **Factory or Field Installed**

##### **Outdoor Air Damper**

- Downflow or Horizontal
- Linked mechanical dampers
- 0 to 25% (fixed) outdoor air adjustable
- Installs in unit
- Includes outdoor air hood
- Automatic model features fully modulating spring return damper motor with plug-in connection
- Manual model features parallel blade, gear-driven dampers with adjustable fixed position

#### **ROOF CURBS**

#### **Field Installed**

- Nailer strip furnished (downflow only)
- Mates to unit
- US National Roofing Contractors Approved
- Shipped knocked down

#### **Downflow**

##### **Hybrid Roof Curbs**

- Interlocking tabs fasten corners together
- No tools required
- Can also be fastened together with furnished hardware
- Available in 8, 14, 18, and 24 inch heights

##### **Adjustable Pitch Curb**

- Fully adjustable pitch curbs (3/4 in. per foot in any direction) provide a level platform for rooftop units allowing flexible installations on roofs with uneven or sloped angles
- Uses interlocking tabs to fasten corners together. No tools required
- Hardware is furnished to connect upper curb with lower curb
- Available in 14 inch height

#### **Horizontal**

- Meet National Roofing Code requirements
- Converts unit from downflow to horizontal (side) air flow
- Return air is on unit, supply air is on curb
- See dimension drawings
- Available in 26, 30, 37 and 41 inch heights

**NOTE** - Requires Horizontal Return Air Panel Kit.

**NOTE** - Optional Insulation Kit is available to help prevent sweating.

#### **Adaptor Curbs (not shown)**

- Curbs are regionally sourced
- Dimensions vary based upon the source

**NOTE** - Contact your local sales representative for a detailed cut sheet with applicable dimensions.

#### **CEILING DIFFUSERS**

#### **Field Installed**

##### **Ceiling Diffusers (Flush or Step-Down)**

- White powder coat finish on diffuser face and grilles
- Insulated UL listed duct liner
- Diffuser box has collars for duct connection
- Step-down diffusers have double deflection blades
- Flush diffusers have fixed blades
- Provisions for suspending
- Internally sealed to prevent recirculation
- Removable return air grille
- Adapts to T-bar ceiling grids or plaster ceilings

##### **Transitions (Supply and Return)**

- Used with diffusers
- Installs in roof curb
- Galvanized steel construction
- Flanges furnished for duct connection to diffusers
- Fully insulated

## HUMIDITROL® DEHUMIDIFICATION SYSTEM OPTION

### OVERVIEW

**NOTE** - Humiditrol® Dehumidification System Only Available For CAV And MSAV® (Multi-Stage Air Volume) Models.

- Factory installed option designed to control humidity
- Provides dehumidification on demand using ASHRAE 90.1 recommended method for comfort conditioning humidity control
- Unit comes equipped with one row reheat coil, solenoid valve and humidity controller
- A thermostat with a dehumidification output, a dehumidistat, or a DDC controller with an isolated output is required to control humidity and must be located in the occupied space

**NOTE** - Remote Mounted Humidity Sensor Kit is required for field installation. The humidity sensor provides input to the Unit Controller which is used to control activation of the dehumidification operation.

### BENEFITS

- Improves indoor air quality
- Helps prevent damage due to high humidity levels
- Improves comfort levels by reducing space humidity levels

### OPERATION

#### No Dehumidification Demand

- The unit will operate conventionally whenever there is a demand for cooling or heating and no dehumidification demand
- Free cooling is only permitted when there is no demand for dehumidification

#### Dehumidification Demand Only

- The Unit Controller is factory set at 60% relative humidity setpoint and can be adjusted at the Unit Controller or with optional Unit Controller Software

**NOTE** - Controls are not furnished and must be ordered extra.

- Reheat operation will initiate on a dehumidification demand and does not require a cooling demand
- The unit will operate in the dehumidification mode until the relative humidity of the conditioned space is below the setpoint
- The reheat coil is sized to provide 68°F to 75°F supply air during reheat operation
- This reduces sensible cooling capacity and extends compressor run time to control humidity when the cooling load is low
- A solenoid valve diverts hot gas from the compressor to the reheat coil
- The cooled and dehumidified air from the evaporator is reheated as it passes through the reheat coil
- The de-superheated and partially condensed refrigerant continues to the outdoor condenser coil where condensing is completed
- Unit will continue to operate in this mode until the dehumidification demand is satisfied

#### Dehumidification and Cooling Demand (Thermostat/ Room Sensor Application)

- If both a dehumidification and a full cooling load demand occur, the system will operate in cooling until the cooling demand is satisfied
- Then the system will energize the dehumidification mode.

### Options/Accessories

#### Humidity Sensor Kit

- Remote Mounted Humidity sensor required with factory installed Humiditrol® Dehumidification Option or Supermarket reheat field selectable option

# HUMIDITROL® DEHUMIDIFICATION SYSTEM OPTION

## REFRIGERANT SCHEMATIC (156H, 180H and 210H MODELS ONLY)

NOTE: Refrigerant circuits one and two operates when there is a first-stage thermostat demand.

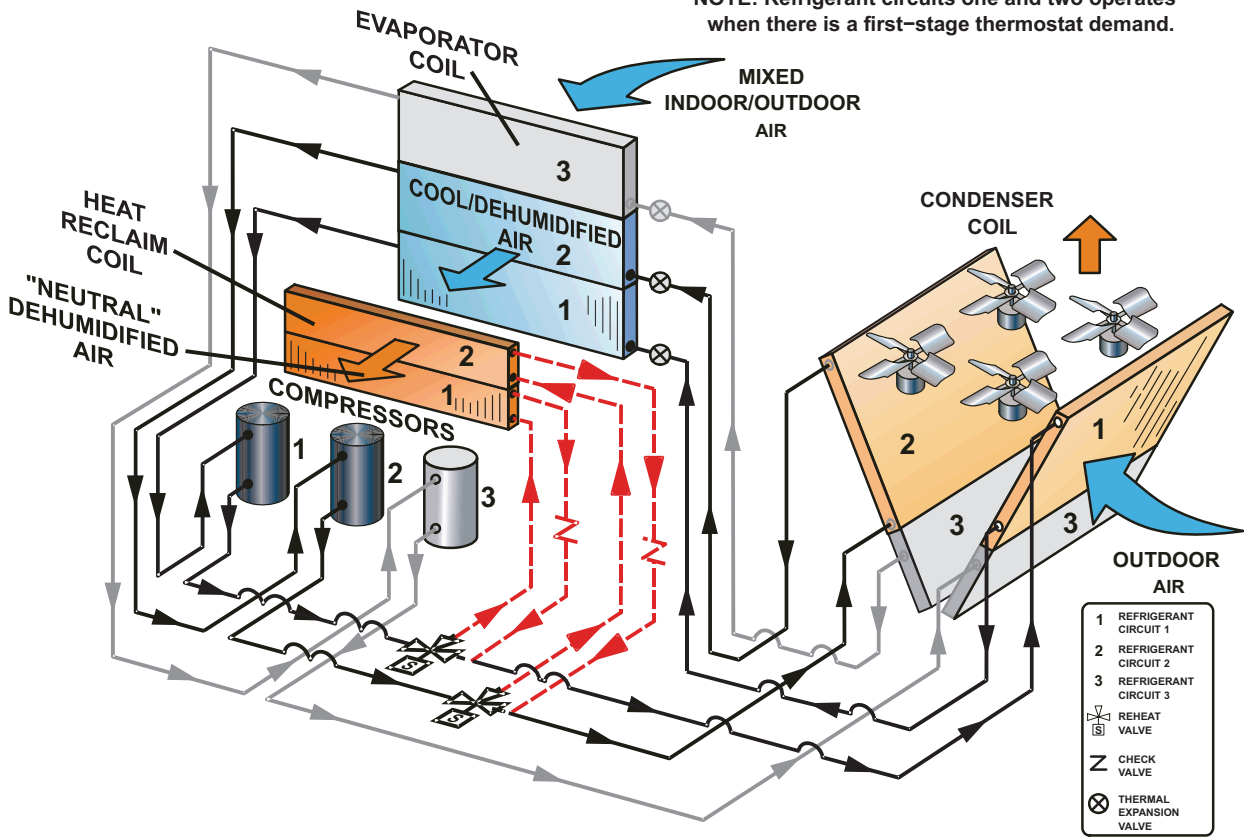

## REFRIGERANT SCHEMATIC (240H and 300S MODELS ONLY)

NOTE: Refrigerant circuits one and two operates when there is a first-stage thermostat demand.

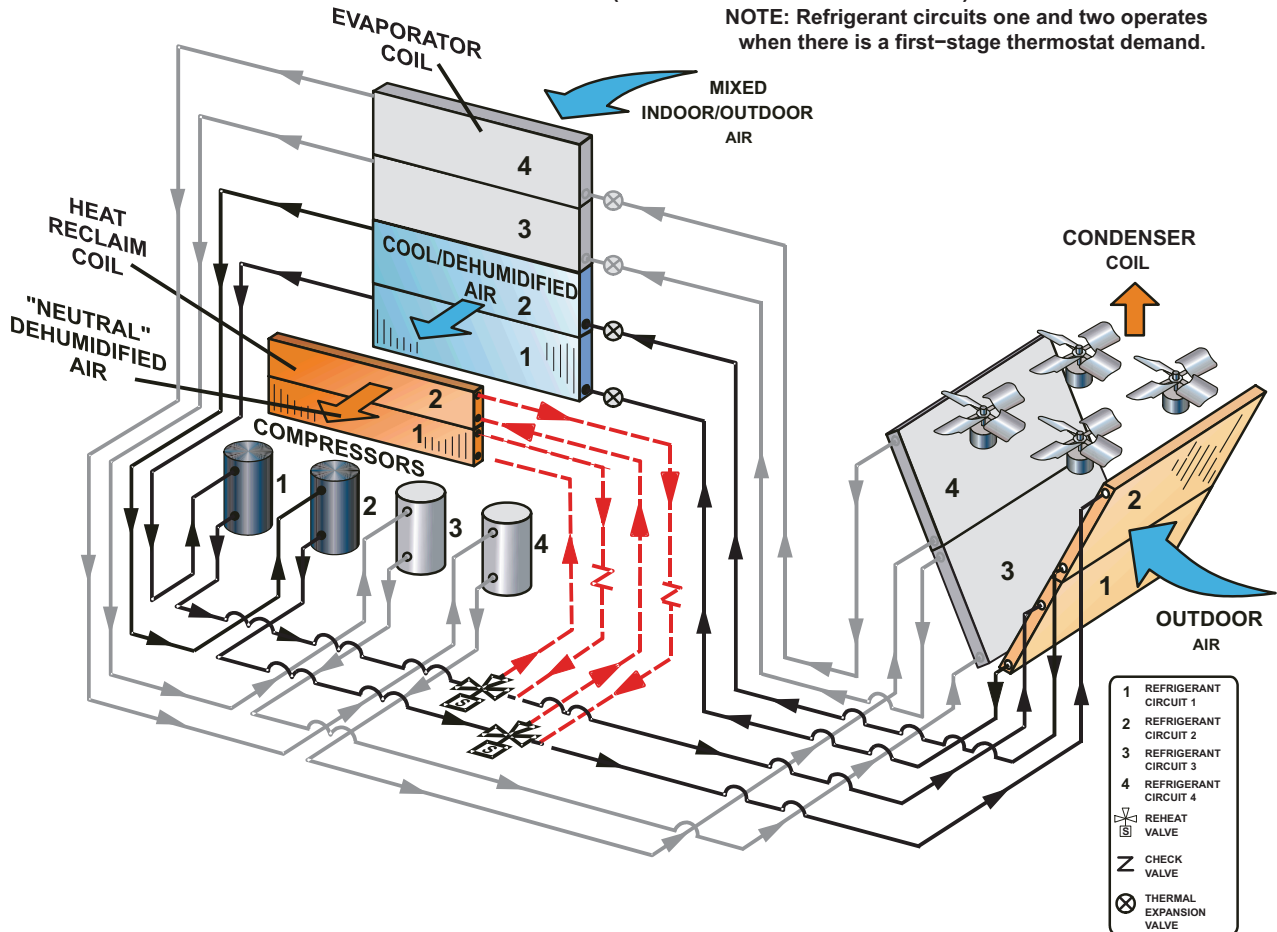



## OPTIONAL CONVENTIONAL TEMPERATURE CONTROL SYSTEMS

### ComfortSense® 8500 Commercial 7 Day Programmable Thermostat

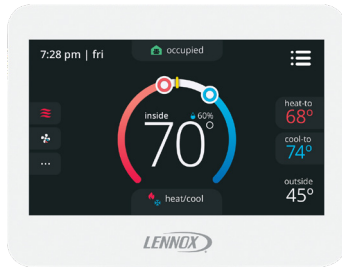

- Fully Communicating Thermostat
- Up to 4 Heat and 4 Cool
- Automatic Changeover between Heating and Cooling Modes
- Designed to maximize Prodigy® Control System Operation
- BACNet Compatible
- Remote Indoor Temperature Sensing (up to nine averaging sensors)
- Intuitive Touchscreen Interface
- Backlit Display
- Relative Humidity Sensor
- Remote Occupancy Sensing
- Outside Air Temperature Display
- Four-Wire Installation
- Scheduled Occupancy Control
- Performance Reports (standalone mode)
- Full Variable-Speed Control (Energence® 3-6 Ton Ultra High Efficiency units only)
- Dehumidification/Humiditrol® Control
- Wallplate Furnished
- ASHRAE and IECC Compliant

### ComfortSense® 7500 Commercial 7-Day Programmable Thermostat



- Four-Stage Heating / Two-Stage Cooling
- Universal Multi-Stage
- Intuitive Touchscreen Interface
- Automatic Changeover between Heating and Cooling
- Full Seven-Day Programming
- Four Time Periods Per Day
- Temperature and Humidity Control
- One-Touch Away Mode
- Holiday Scheduling
- Smooth Setback Recovery (SSR)
- Performance Reports
- Notifications/Reminders
- Dehumidification/Humiditrol® Control for Split Systems and Rooftop Units
- Economizer Relay Control
- Backlit Display
- Wallplate Furnished
- FDD, ASHRAE and IECC Compliant

## OPTIONAL CONVENTIONAL TEMPERATURE CONTROL SYSTEMS

### ComfortSense® 3000 Commercial 5-2 Day Programmable Thermostat

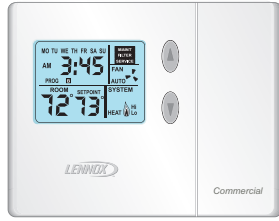

- Two-Stage Heating / Two-Stage Cooling
- Conventional Systems
- Intuitive Interface
- 5-2 Day Programming
- Program Hold
- Remote Indoor Temperature Sensing
- Smooth Setback Recovery (SSR)
- Economizer Relay Control
- Maintenance/Filter/Service Reminders
- Backlit Display
- Wallplate Furnished
- Simple Up and Down Temperature Control

### ComfortSense® Non-Programmable Thermostat

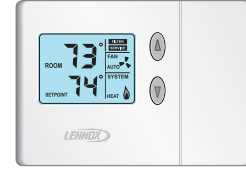

- One-Stage Heating / Cooling
- Conventional Systems
- Intuitive Interface
- Manual Changeover
- Backlit Display
- Simple Up and Down Temperature Control

## OPTIONAL CONVENTIONAL TEMPERATURE CONTROL SYSTEMS

Description	Model No.	Catalog No.
<b>ComfortSense® 8500 Commercial 7 Day Programmable Thermostat</b>		
	No CO <sub>2</sub> Sensing	C0STAT03FF2L
	With CO <sub>2</sub> Sensing	C0STAT22FF2L
Sensors/Accessories	<sup>1</sup> Remote non-adjustable wall-mount 10k	C0SNZN73AE1-
	<sup>1</sup> Remote non-adjustable wall-mount 11k	C0SNZN08AE1
	Locking cover (clear)	C0MISC15AE1
<sup>1</sup> Up to nine of the same type remote temperature sensors can be connected in parallel.		
<b>Sysbus Network Cable (Yellow) for ComfortSense 8500</b>		
Twisted pair 100% shielded communication cable, Red and Black	500 ft. box	C0MISC00AE1-
22 AWG, yellow jacket, rated at 75°C, 300V, Plenum rated	1000 ft. box	C0MISC04AE1-
Insulation - Low smoke PVC, NEC, CMP	2500 ft. roll	C0MISC01AE1-
<b>ComfortSense® 7500 Commercial 7-Day Programmable Thermostat</b>		
	C0STAT06FF2L	17G74
Sensors/Accessories	<sup>2</sup> Remote non-adjustable wall-mount 20k	C0SNZN01AE2-
	<sup>2</sup> Remote non-adjustable wall-mount 10k	C0SNZN73AE1-
	Remote non-adjustable discharge air (duct mount)	C0SNDC00AE1-
	Outdoor temperature sensor	C0SNSR03AE1-
	Universal thermostat locking guard (clear)	C0MISC15AE1-
<sup>2</sup> Remote wall-mount sensors can be applied in any of the following combinations: One Sensor - (1) 47W36 Two Sensors - (2) 47W37 Three Sensors - (2) 47W36 and (1) 47W37 Four Sensors - (4) 47W36 Five Sensors - (3) 47W36 and (2) 47W37		
<b>ComfortSense® 3000 Commercial 5-2 Day Programmable Thermostat</b>		
	C0STAT05FF1L	11Y05
Sensors/Accessories	Remote non-adjustable wall mount 10k averaging	C0SNZN73AE1-
	Thermostat wall mounting plate	C0MISC17AE1-
<b>ComfortSense® Non-Programmable Thermostat</b>		
	C0STAT12AE1L	51M32

**Objective:** Outline the unit functions as a result of room thermostat or zone sensor demands.

**Given:** When economizer is present, it will function as an integral part of the unit cooling system. When not present, unit will function as if economizer is present but outdoor ambient is high and sensed as not suitable.

### **UNIT OPERATION WITH 2-STAGE THERMOSTAT (2 COOLING STAGES, Y1, Y2) - 3 AND 4 COMPRESSORS MODELS**

#### **SUPPLY AIR BLOWER SPEED**

Unit has the following supply air blower speed settings:

- Ventilation speed
- Cooling speed - Low
- Cooling speed - High
- Heating speed
- Smoke speed (Used only in smoke removal option - not discussed)

#### **<sup>1</sup> Unit Features An Economizer And Outdoor Air Is Suitable**

##### **Y1 Demand:**

All compressors are off, supply air blower is on low cooling speed to minimize blower power consumption, economizer modulates (minimum to maximum open position) to maintain 55°F supply air temperature (default unit controller setting).

##### **Y2 Demand:**

All compressors are off, supply air blower is on high cooling speed providing higher cooling capacity, and economizer modulates to maintain 55°F supply air temperature.

If economizer stays at maximum open for 3 minutes, 1st stage compressors (compressor 1 and 2) are energized while supply air blower stays on high cooling speed providing maximum cooling capacity.

<sup>1</sup> *Outdoor air suitability is determined by the energy state of outdoor ambient (enthalpy or sensible) and its ability to achieve the desired free cooling effects. Outdoor air suitability can also be determined by a third party controller and provided to the RTU via a network connection.*

#### **Unit Does Not Feature An Economizer Or Outdoor Air Is Not Suitable**

##### **Y1 Demand:**

1st stage compressors operate and supply air blower operates at low cooling speed.

##### **Y2 Demand:**

All compressors operate and supply air blower operates at high cooling speed.

#### **Dehumidification Mode**

If a unit with Humiditrol® Dehumidification Option receives a call for dehumidification, economizer free cooling is locked out.

##### **Call For Dehumidification, No Y1, Y2 Demand:**

1st stage compressors (1 & 2) operate, supply air blower operates at high cooling speed, and the reheat valves are energized.

##### **Y1 Demand With A Call For Dehumidification:**

All compressors operate, supply air blower operates at high cooling speed and the reheat valves are energized.

##### **Y2 Demand With A Call For Dehumidification:**

All compressors operate, supply air blower operates at high cooling speed, and the reheat valves are de-energized.

**UNIT WITH 3-STAGE THERMOSTAT (3 COOLING STAGES, Y1, Y2, Y3) - 3 AND 4 COMPRESSORS MODELS, OR ZONE SENSOR (4 COOLING STAGES, Y1, Y2, Y3, Y4) - 3 COMPRESSORS MODELS****SUPPLY AIR BLOWER SPEED**

Unit has following supply air blower speed setting:

- Ventilation speed
- Cooling speed - Low
- Cooling speed - Medium
- Cooling speed - High
- Heating speed
- Smoke speed (Used only in smoke removal option - not discussed)

**<sup>1</sup> Unit Features An Economizer And Outdoor Air Is Suitable****3 Compressor Models****Y1 Demand:**

All compressors are off, supply air blower is on low cooling speed to minimize blower power consumption, economizer modulates (minimum to maximum open position) to maintain 55°F supply air temperature (default unit controller setting).

**Y2 Demand:**

All compressors are off, supply air blower is on high cooling speed providing higher cooling capacity, economizer modulates (minimum to maximum open position) to maintain 55°F supply air temperature (default unit controller setting).

If economizer stays at maximum open for 3 minutes then compressor 1 is energized while supply air blower stays on high cooling speed. After compressor is energized the economizer stays at maximum open.

**Y3 Demand:**

Compressors 1 and 2 are energized while supply air blower stays on high cooling speed. After compressors are energized the economizer stays at maximum.

**Y4 (Zone Sensor Only) Demand:**

All compressors are energized and supply air blower stays on high cooling speed.

**4 Compressor Models****Y1 Demand:**

All compressors are off, supply air blower is on low cooling speed to minimize blower power consumption, economizer modulates (minimum to maximum open position) to maintain 55°F supply air temperature (default unit controller setting).

**Y2 Demand:**

All compressors are off, supply air blower is on high cooling speed providing higher cooling capacity, economizer modulates (minimum to maximum open position) to maintain 55°F supply air temperature (default unit controller setting).

If economizer stays at maximum open for 3 minutes then compressors 1 and 2 are energized while supply air blower stays on high cooling speed. After compressors are energized the economizer stays at maximum open.

**Y3 Demand:**

Compressors 1, 2 and 3 are energized and supply air blower stays on high cooling speed.

<sup>1</sup> Outdoor air suitability is determined by the energy state of outdoor ambient (enthalpy or sensible) and its ability to achieve the desired free cooling effects. Outdoor air suitability can also be determined by a third party controller and provided to the RTU via a network connection.

**UNIT WITH 3-STAGE THERMOSTAT (3 COOLING STAGES, Y1, Y2, Y3) - 3 AND 4 COMPRESSORS MODELS, OR ZONE SENSOR (4 COOLING STAGES, Y1, Y2, Y3, Y4) - 3 COMPRESSORS MODELS (CONTINUED)****Unit Does Not Feature An Economizer Or Outdoor Air Is Not Suitable****3 Compressor Units****Y1 Demand:**

Compressor 1 operates and supply air blower operates at low cooling speed.

**Y2 Demand:**

Compressors 1 and 2 operate and supply air blower operates at medium cooling speed.

**Y3 or Y4 (Zone Sensor Only) Demand:**

All compressors operate and supply air blower operates at high cooling speed .

**4 Compressor Units****Y1 Demand:**

Compressors 1 and 2 operate and supply air blower operates at low cooling speed.

**Y2 demand:**

Compressors 1, 2, and 3 operate and supply air blower operates at medium cooling speed.

**Y3 demand:**

All compressors operate and supply air blower operates at high cooling speed.

**Dehumidification Mode**

If a unit with Humiditrol® Dehumidification Option receives a call for dehumidification, economizer free cooling is locked out.

**Call For Dehumidification, No Y1, Y2, Y3 Demand:**

Compressor 1 and 2 operate, supply air blower operates at high cooling speed, and both reheat valves are energized.

**Y1 Demand With A Call For Dehumidification:**

All compressors operate, supply air blower operates at high cooling speed and both reheat valves are energized.

**Y2 Demand With A Call For Dehumidification:**

All compressors operate, supply air blower operates at high cooling speed, and the reheat valve of refrigeration circuit 1 is energized while the reheat valve of refrigeration circuit 2 is de-energized.

**Y3 or Y4 (Zone Sensor Only) Demand:**

All compressors operate, supply air blower operates at high cooling speed, and both reheat valves are de-energized.



**UNIT WITH ZONE SENSOR (4 COOLING STAGES, Y1, Y2, Y3, Y4) – 4 COMPRESSORS MODELS****SUPPLY AIR BLOWER SPEED**

Unit has following supply air blower speed setting:

- Ventilation speed
- Cooling speed - Low
- Cooling speed - Medium-Low
- Cooling speed - Medium-High
- Cooling speed - High
- Heating speed
- Smoke speed (Used only in smoke removal option - not discussed)

**<sup>1</sup> Unit Features An Economizer And Outdoor Air Is Suitable****Y1 Demand:**

All compressors are off, supply air blower is on low cooling speed to minimize blower power consumption, economizer modulates (minimum to maximum open position) to maintain 55°F supply air temperature (default unit controller setting).

**Y2 Demand:**

All compressors are off, supply air blower is on high cooling speed providing higher cooling capacity, and economizer modulates to maintain 55°F supply air temperature.

If economizer stays at maximum open for 3 minutes, compressor 1 is energized while supply air blower stays on high cooling speed. After compressor 1 is energized the economizer stays at maximum open.

**Y3 Demand:**

Compressor 1 and 2 are energized while supply air blower is on high cooling speed providing even higher cooling capacity.

**Y4 Demand:**

All compressors are energized while supply air blower is on high cooling speed providing maximum cooling capacity.

<sup>1</sup> *Outdoor air suitability is determined by the energy state of outdoor ambient (enthalpy or sensible) and its ability to achieve the desired free cooling effects. Outdoor air suitability can also be determined by a third party controller and provided to the RTU via a network connection.*

**Unit Does Not Feature An Economizer Or Outdoor Air Is Not Suitable****Y1 demand:**

Compressor 1 operates and supply air blower operates at low cooling speed.

**Y2 demand:**

Compressors 1 and 2 operate and supply air blower operates at medium-low cooling speed.

**Y3 demand:**

Compressors 1, 2, and 3 operate and supply air blower operates at medium-high cooling speed.

**Y4 demand:**

All compressors operate and supply air blower operates at high cooling speed.

**UNIT WITH ZONE SENSOR (4 COOLING STAGES, Y1, Y2, Y3, Y4) – 4 COMPRESSORS MODELS (CONTINUED)****Dehumidification Mode**

If a unit with Humiditrol® Dehumidification Option receives a call for dehumidification, economizer free cooling is locked out.

**Call For Dehumidification, No Y1, Y2, Y3, Y4 Demand:**

Compressors 1 and 2 operate, supply air blower operates at high cooling speed, and both reheat valves are energized.

**Y1 Demand With A Call For Dehumidification:**

Compressors 1, 2, and 3 operate, supply air blower operates at high cooling speed and both reheat valves are energized.

**Y2 Demand With A Call For Dehumidification:**

All compressors operate, supply air blower operates at high cooling speed, and both reheat valves are energized.

**Y3 Demand With A Call For Dehumidification:**

All compressors operate, supply air blower operates at high cooling speed, and the reheat valve of compressor 1 is energized while the reheat valve of compressor 2 is de-energized.

**Y4 Demand With A Call For Dehumidification:**

All compressors operate, supply air blower operates at high cooling speed, and the reheat valves are de-energized.

**Heating Mode (Electric Heat)**

*NOTE - HEATING MODE IS THE SAME FOR ALL CONTROL OPTIONS.*

**W1 Demand:**

1st stage electric heat is energized and the supply air blower operates at heating speed.

**W2 Demand:**

2nd stage electric heat is energized and the supply air blower operates at heating speed (45, 60 or 90 kW electric heat option only).

**Modulating Outdoor Air Damper**

The minimum damper position for “occupied low blower” and “occupied high blower” is adjusted during unit setup to provide minimum fresh air requirements per ASHRAE 62.1 at the corresponding supply air blower speeds.

- When supply air blower is off or the unit is in unoccupied mode, the outdoor air damper is closed.
- When unit is in occupied mode and supply air blower is operating at a speed below the “midpoint” blower speed, the outdoor air damper is at minimum “low blower” position.
- When unit is in occupied mode and supply air blower is operating at a speed equal to or above the “midpoint” blower speed, the outdoor air damper is at minimum “high blower” position.

*NOTE - The “midpoint” blower speed is an average of the minimum and maximum blower speed (minimum speed + maximum speed divided by 2).*

**Power Exhaust Operation**

*NOTE - POWER EXHAUST OPERATION IS THE SAME FOR ALL CONTROL OPTIONS*

MSAV® models are equipped with 2-stage power exhaust fans. Power exhaust fans operate when economizer outdoor air dampers are 50% open (adjustable). Power exhaust operates in 1st stage (one fan) up to 70% of supply air blower speed. 2nd stage power exhaust fans (both fans) operate when supply air blower speed is above 70% (adjustable) of full speed.

**VAV UNITS IN ZONING APPLICATIONS OPERATING WITH DISCHARGE AIR CONTROL - 156/180 MODELS ONLY (4 HEAT / 3 COOL)****SUPPLY AIR BLOWER SPEED**

Unit has the following supply air blower speed settings:

- Ventilation Speed
- Cooling Speed - Fully modular based on supply duct static pressure
- Heating Speed
- Smoke Speed (Used only in smoke removal option - not discussed)

**Cooling Mode (3 Cool)**

- Discharge air temperature (DAT) can be used to control unit staging.
- DAT default setpoint = 55°F. Unit will stage compressors as required to maintain the setpoint when provided with Y1 thermostat demand.
- Increasing compressor stages provides more cooling capacity while decreasing compressor stages provides less cooling capacity.

**<sup>1</sup> Unit Features An Economizer And Outdoor Air Is Suitable****Cooling Stage 1**

All compressors are off, supply air blower operates to maintain duct static pressure, economizer modulates (minimum to maximum open position) to maintain 55°F supply air temperature (default unit controller setting).

**Cooling Stage 2**

All compressors are off, supply air blower operates to maintain duct static pressure, and economizer modulates to maintain 55°F supply air temperature. If economizer stays at maximum open for 3 minutes, compressor 1 is energized while supply air blower operates to maintain duct static pressure. After compressor 1 is energized, the economizer stays at maximum open.

**Cooling Stage 3**

Compressor 1 and 2 are energized while supply air blower operates to maintain duct static pressure.

<sup>1</sup> Outdoor air suitability is determined by the energy state of outdoor ambient (enthalpy or sensible) and its ability to achieve the desired free cooling effects. Outdoor air suitability can also be determined by a third party controller and provided to the RTU via a network connection.

**Unit Does Not Feature An Economizer Or Outdoor Air Is Not Suitable****Cooling Stage 1**

Compressor 1 operates and supply air blower operates to maintain duct static pressure.

**Cooling Stage 2**

Compressors 1 and 2 operate and supply air blower operates to maintain duct static pressure.

**Cooling Stage 3**

Compressors 1, 2, and 3 operate and supply air blower operates to maintain duct static pressure.

**Heating Mode (4 Heat)**

- Room sensors (when connected to S-Bus) or Discharge air temperature (DAT) can be used to control up to four stages of electric heat.
- DAT default setpoint = 110°F. Unit will stage heating as required to maintain the setpoint when provided with W1 demand.
- Room sensor occupied setpoint default = 70°F. Unit will stage heating as required to maintain the setpoint.
- Increasing heat stages provides more heating capacity while decreasing heat stages provides less heating capacity.
- Blower set to Heating Speed for all stages.

**VAV UNITS IN ZONING APPLICATIONS OPERATING WITH DISCHARGE AIR CONTROL - 240 MODELS ONLY  
(4 HEAT / 4 COOL)****SUPPLY AIR BLOWER SPEED**

Unit has the following supply air blower speed settings:

- Ventilation Speed
- Cooling Speed - Fully modular based on supply duct static pressure
- Heating Speed
- Smoke Speed (Used only in smoke removal option - not discussed)

**Cooling Mode (4 Cool)**

- Discharge air temperature (DAT) can be used to control unit staging.
- DAT default setpoint = 55°F. Unit will stage compressors as required to maintain the setpoint when provided with Y1 thermostat demand.
- Increasing compressor stages provides more cooling capacity while decreasing compressor stages provides less cooling capacity.

**<sup>1</sup> Unit Features An Economizer And Outdoor Air Is Suitable****Cooling Stage 1**

All compressors are off, supply air blower operates to maintain duct static pressure, economizer modulates (minimum to maximum open position) to maintain 55°F supply air temperature (default unit controller setting).

**Cooling Stage 2**

All compressors are off, supply air blower operates to maintain duct static pressure, and economizer modulates to maintain 55°F supply air temperature. If economizer stays at maximum open for 3 minutes, compressor 1 is energized while supply air blower operates to maintain duct static pressure. After compressor 1 is energized, the economizer stays at maximum open.

**Cooling Stage 3**

Compressor 1 and 2 are energized while supply air blower operates to maintain duct static pressure.

**Cooling Stage 4**

All compressors are energized while supply air blower operates to maintain duct static pressure.

<sup>1</sup> Outdoor air suitability is determined by the energy state of outdoor ambient (enthalpy or sensible) and its ability to achieve the desired free cooling effects. Outdoor air suitability can also be determined by a third party controller and provided to the RTU via a network connection.

**Unit Does Not Feature An Economizer Or Outdoor Air Is Not Suitable****Cooling Stage 1**

Compressor 1 operates and supply air blower operates to maintain duct static pressure.

**Cooling Stage 2**

Compressors 1 and 2 operate and supply air blower operates to maintain duct static pressure.

**Cooling Stage 3**

Compressors 1, 2, and 3 operate and supply air blower operates to maintain duct static pressure.

**Cooling Stage 4**

All compressors operate and supply air blower operates to maintain duct static pressure.

**Heating Mode (4 Heat)**

- Room sensors (when connected to S-Bus) or Discharge air temperature (DAT) can be used to control up to four stages of electric heat.
- DAT default setpoint = 110°F. Unit will stage heating as required to maintain the setpoint when provided with W1 demand.
- Room sensor occupied setpoint default = 70°F. Unit will stage heating as required to maintain the setpoint.
- Increasing heat stages provides more heating capacity while decreasing heat stages provides less heating capacity.
- Blower set to Heating Speed for all stages.

**VAV UNITS IN ZONING APPLICATIONS OPERATING WITH DISCHARGE AIR CONTROL (4 HEAT / 4 COOL)**  
**(CONTINUED)****Modulating Outdoor Air Damper**

The minimum damper position for “occupied low blower” and “occupied high blower” is adjusted during unit setup to provide minimum fresh air requirements per ASHRAE 62.1 at the corresponding supply air blower speeds. When supply air blower is off or the unit is in unoccupied mode, the outdoor air damper is closed.

When unit is in occupied mode and supply air blower is operating at a speed below the “midpoint” blower speed, the outdoor air damper is at minimum “low blower” position.

When unit is in occupied mode and supply air blower is operating at a speed equal to or above the “midpoint” blower speed, the outdoor air damper is at minimum “high blower” position.

*NOTE - The “midpoint” blower speed is an average of the minimum and maximum blower speed ((minimum speed + maximum speed) divided by 2).*



## OPTIONS / ACCESSORIES

Item Description	Model Number	Catalog Number	Unit Model No				
			156	180	210	240	300
<b>COOLING SYSTEM</b>							
Condensate Drain Trap	PVC - C1TRAP20AD2	<b>76W26</b>	OX	OX	OX	OX	OX
	Copper - C1TRAP10AD2	<b>76W27</b>	OX	OX	OX	OX	OX
Conventional Fin/Tube Condenser Coil (replaces Environ™ Coil System)		Factory	0	0	0	0	0
Corrosion Protection		Factory	0	0	0	0	0
Drain Pan Overflow Switch	E1SNSR71AD1	<b>68W88</b>	OX	OX	OX	OX	OX
Efficiency	High		0	0	0	0	
	Standard						0
Refrigerant Type		R-410A	0	0	0	0	0
Service valves (not for Environ™ Coil System or Humiditrol® Dehumidification)		Factory	0	0	0	0	0
<b>BLOWER - SUPPLY AIR</b>							
Blower Option	CAV (Constant Air Volume)	Factory	0	0	0	0	0
	VAV (Variable Air Volume) supply air blower option (Without VFD Bypass Control)	Factory	0	0		0	
	MSAV® (Multi-Stage Air Volume) supply air blower option (With VFD Bypass Control)	Factory	0	0	0	0	0
	MSAV® (Multi-Stage Air Volume) supply air blower option (Without VFD Bypass Control)	Factory	0	0	0	0	0
Motors - CAV (Constant Air Volume)	Belt Drive (standard efficiency) - 2 hp	Factory	0				
	Belt Drive (standard or high efficiency) - 3 hp	Factory	0	0	0		
	Belt Drive (standard efficiency) - 5 hp	Factory	0	0	0	0	0
	Belt Drive (standard efficiency) - 7.5 hp	Factory		0	0	0	0
	Belt Drive (standard efficiency) - 10 hp	Factory				0	0
Motors - VAV (Variable Air Volume)	Belt Drive (standard or high efficiency) - 2 hp	Factory	0				
	Belt Drive (standard or high efficiency) - 3 hp	Factory	0	0			
	Belt Drive (standard efficiency) - 5 hp	Factory	0	0		0	
	Belt Drive (standard efficiency) - 7.5 hp	Factory		0		0	
	Belt Drive (standard efficiency) - 10 hp	Factory				0	
Motors - MSAV® (Multi-Stage Air Volume)	Belt Drive (standard efficiency) - 2 hp	Factory	0				
	Belt Drive (standard efficiency) - 3 hp	Factory	0	0	0		
	Belt Drive (standard efficiency) - 5 hp	Factory	0	0	0	0	0
	Belt Drive (standard efficiency) - 7.5 hp	Factory		0	0	0	0
	Belt Drive (standard efficiency) - 10 hp	Factory				0	0
Drive Kits See Blower Data Tables for usage and selection	Kit #1 535-725 rpm	Factory	0	0	0		
	Kit #2 710-965 rpm	Factory	0	0	0		
	Kit #3 685-856 rpm	Factory	0	0	0	0	0
	Kit #4 850-1045 rpm	Factory	0	0	0	0	0
	Kit #5 945-1185 rpm	Factory	0	0	0	0	0
	Kit #6 850-1045 rpm	Factory		0	0	0	0
	Kit #7 945-1185 rpm	Factory		0	0	0	0
	Kit #8 1045-1285 rpm	Factory		0	0	0	0
	Kit #10 1045-1285 rpm	Factory				0	0
	Kit #11 1135-1365 rpm	Factory				0	0
	Blower Belt Auto-Tensioner	Factory	0	0	0	0	0
<b>CABINET</b>							
Combination Coil/ Hail Guards	Environ™ Coil System - C1GARD52C12	<b>15T92</b>	X				
	Environ™ Coil System - C1GARD52C22	<b>15T93</b>		X	X	X	X
	Conventional Fin/Tube Condenser Coil - C1GARD51C11	<b>13T08</b>	X				
	Conventional Fin/Tube Condenser Coil - C1GARD51C21	<b>13T12</b>		X	X	X	X

NOTE - Catalog and model numbers shown are for ordering field installed accessories.

OX = Configure To Order (Factory Installed) or Field Installed

0 = Configure To Order (Factory Installed)

X = Field Installed

## OPTIONS / ACCESSORIES

Item Description	Model Number	Catalog Number	Unit Model No				
			156	180	210	240	300
<b>CONTROLS</b>							
Blower Proving Switch	C1SNSR35FF1	<b>53W65</b>	OX	OX	OX	OX	OX
Commercial Controls	Prodigy® Control System - BACnet® Module - C0CTRL60AE1L	59W51	OX	OX	OX	OX	OX
	Prodigy® Control System - LonTalk® Module - C0CTRL65FF1	<b>54W27</b>	OX	OX	OX	OX	OX
	Novar® LSE L Connection® Building Automation System	Factory - - -	O	O	O	O	O
Dirty Filter Switch	E1SNSR55C-1	<b>53W68</b>	OX	OX	OX	OX	OX
Fresh Air Tempering	C1SNSR75AD1	<b>58W63</b>	OX	OX	OX	OX	OX
General Purpose Control Kit	E1GPBK30C1	<b>13J78</b>	X	X	X	X	X
Smoke Detector - Supply or Return (Power board and one sensor)	C1SNSR44C-1	<b>83W40</b>	OX	OX	OX	OX	OX
Smoke Detector - Supply and Return (Power board and two sensors)	C1SNSR43C-1	<b>83W41</b>	OX	OX	OX	OX	OX
<b>INDOOR AIR QUALITY</b>							
<b>Air Filters</b>							
Healthy Climate® High Efficiency Air Filters 24 x 24 x 2 (Order 6 per unit)	MERV 8 - C1FLTR15C-1-	<b>54W67</b>	OX	OX	OX	OX	OX
	MERV 13 - C1FLTR40C-1-	<b>52W40</b>	OX	OX	OX	OX	OX
Replacement Media Filter With Metal Mesh Frame (includes non-pleated filter media)	C1FLTR30C-1-	<b>44N61</b>	OX	OX	OX	OX	OX
<b>Indoor Air Quality (CO<sub>2</sub>) Sensors</b>							
Sensor - Wall-mount, off-white plastic cover with LCD display	C0SNSR50AE1L	<b>77N39</b>	X	X	X	X	X
Sensor - Wall-mount, off-white plastic cover, no display	C0SNSR52AE1L	<b>87N53</b>	X	X	X	X	X
Sensor - Black plastic case with LCD display, rated for plenum mounting	C0SNSR51AE1L	<b>87N52</b>	X	X	X	X	X
Sensor - Wall-mount, black plastic case, no display, rated for plenum mounting	C0MISC19AE1	<b>87N54</b>	X	X	X	X	X
CO <sub>2</sub> Sensor Duct Mounting Kit - for downflow applications	C0MISC19AE1-	<b>85L43</b>	X	X	X	X	X
Aspiration Box - for duct mounting non-plenum rated CO <sub>2</sub> sensors (87N53 or 77N39)	C0MISC16AE1-	<b>90N43</b>	X	X	X	X	X
<b>UVC Germicidal Light Kit</b>							
<sup>1</sup> Healthy Climate® UVC Light Kit (110/230v-1ph)	C1UVCL10C-1	<b>54W65</b>	X	X	X	X	X
<b>ELECTRICAL</b>							
Voltage 60 hz	208/230V - 3 phase	Factory	O	O	O	O	O
	460V - 3 phase	Factory	O	O	O	O	O
	575V - 3 phase	Factory	O	O	O	O	O
Disconnect Switch (see Electric Heat Tables for usage,	80 amp - C1DISC080C-1	<b>54W85</b>	OX	OX	OX	OX	OX
	150 amp - C1DISC150C-1	<b>54W86</b>	OX	OX	OX	OX	OX
	250 amp - C1DISC250C-1	<b>54W87</b>	OX	OX	OX	OX	OX
<sup>2</sup> Short-Circuit Current Rating (SCCR) of 100kA (includes Phase/Voltage Detection)		Factory	O	O	O	O	O
GFI Service Outlets	15 amp non-powered, field-wired (208/230V, 460V, 575V) LTAGFIK10/15	<b>74M70</b>	OX	OX	OX	OX	OX
	15 amp factory-wired and powered (208/230V, 460V, 575V)	Factory	O	O	O	O	O
	20 amp non-powered, field-wired (575V only) C1GFC120FF1	<b>67E01</b>	OX	OX	OX	OX	OX
Weatherproof Cover for GFI	C1GFC199FF1	<b>10C89</b>	X	X	X	X	X
Phase/Voltage Detection (Optional for CAV options only, furnished with VAV or MSAV® option)		Factory	O	O	O	O	O

<sup>1</sup> Lamps operate on 110-230V single-phase power supply. Step-down transformer must be field supplied for field installation in 460V and 575V rooftop units (transformer is furnished for factory installed light kits). Alternately, a separate 110V power supply may be used to directly power the UVC ballast(s)

<sup>2</sup> Disconnect Switch not available with higher SCCR option. Short-Circuit Current Rating option not available on field installed electric heat or 90kW electric heat (208/240V) models.

NOTE - Catalog and model numbers shown are for ordering field installed accessories.

OX = Configure To Order (Factory Installed) or Field Installed

O = Configure To Order (Factory Installed)

X = Field Installed

## OPTIONS / ACCESSORIES

Item Description	Model Number	Catalog Number	Unit Model No				
			156	180	210	240	300
<b>ELECTRIC HEAT</b>							
15 kW	208/230V-3ph - C1EH0150C-1Y	<b>53W84</b>	OX	OX	OX	OX	OX
	460V-3ph - C1EH0150C-1G	<b>53W86</b>	OX	OX	OX	OX	OX
	575V-3ph - C1EH0150C-1J	<b>53W87</b>	OX	OX	OX	OX	OX
30 kW	208/230V-3ph - C1EH0300C11Y	<b>53W88</b>	OX				
	460V-3ph - C1EH0300C11G	<b>53W90</b>	OX				
	575V-3ph - C1EH0300C11J	<b>53W91</b>	OX				
	208/230V-3ph - C1EH0300C21Y	<b>53W92</b>		OX	OX	OX	OX
	460V-3ph - C1EH0300C21G	<b>53W94</b>		OX	OX	OX	OX
	575V-3ph - C1EH0300C21J	<b>53W95</b>		OX	OX	OX	OX
45 kW	208/230V-3ph - C1EH0450C11Y	<b>53W96</b>	OX				
	460V-3ph - C1EH0450C11G	<b>53W98</b>	OX				
	575V-3ph - C1EH0450C11J	<b>53W99</b>	OX				
	208/230V-3ph - C1EH0450C21Y	<b>54W00</b>		OX	OX	OX	OX
	460V-3ph - C1EH0450C21G	<b>54W02</b>		OX	OX	OX	OX
	575V-3ph - C1EH0450C21J	<b>54W03</b>		OX	OX	OX	OX
60 kW	208/230V-3ph - C1EH0600C11Y	<b>54W04</b>	OX				
	460V-3ph - C1EH0600C11G	<b>54W06</b>	OX				
	575V-3ph - C1EH0600C11J	<b>54W07</b>	OX				
	208/230V-3ph - C1EH0600C21Y	<b>54W08</b>		OX	OX	OX	OX
	460V-3ph - C1EH0600C21G	<b>54W10</b>		OX	OX	OX	OX
	575V-3ph - C1EH0600C21J	<b>54W11</b>		OX	OX	OX	OX
90 kW	208/230V-3ph - C1EH0900C-1Y	<b>54W12</b>			OX	OX	OX
	460V-3ph - C1EH0900C-1G	<b>54W14</b>			OX	OX	OX
	575V-3ph - C1EH0900C-1J	<b>54W15</b>			OX	OX	OX
SCR (Silicon Controlled Rectifier) Electric Heat Control		Factory	O	O	O	O	O
NOTE - The SCR option is not available with 45 kW, 60 kW and 90kW electric heat (208/230V) models.							
Thermostat (required)		<b>Y9682</b>	X	X	X	X	X
Duct Sensor (required)		<b>Y9683</b>	X	X	X	X	X

## ECONOMIZER

### High Performance Economizer (Approved for California Title 24 Building Standards / AMCA Class 1A Certified)

High Performance Economizer	E1ECON17C-2	<b>16Y98</b>	OX	OX	OX	OX	OX
Downflow or Horizontal - Includes Outdoor Air Hood.							
Order Downflow or Horizontal Barometric Relief Dampers separately.							

### Economizer Controls

Differential Enthalpy (Not for Title 24)	Order 2 - C1SNSR64FF1	<b>53W64</b>	OX	OX	OX	OX	OX
Sensible Control	Sensor is Furnished	Factory	O	O	O	O	O
Single Enthalpy (Not for Title 24)	C1SNSR64FF1	<b>53W64</b>	OX	OX	OX	OX	OX
Global Control	Sensor Field Provided	Factory	O	O	O	O	O
Building Pressure Control	E1GPBK20C1	<b>13J77</b>	X	X	X	X	X
Outdoor Air CFM Control	E1GPBK10C1	<b>13J76</b>	X	X	X	X	X

### Barometric Relief Dampers With Exhaust Hood

Downflow Barometric Relief Dampers	C1DAMP50C	<b>54W78</b>	OX	OX	OX	OX	OX
Horizontal Barometric Relief Dampers	LAGEDH18/24	<b>16K99</b>	X	X	X	X	X

## OUTDOOR AIR

### Outdoor Air Dampers With Outdoor Air Hood

Motorized	C1DAMP20C-1	<b>13U04</b>	OX	OX	OX	OX	OX
Manual	C1DAMP10C-2	<b>13U05</b>	OX	OX	OX	OX	OX

NOTE - Catalog and model numbers shown are for ordering field installed accessories.

OX = Configure To Order (Factory Installed) or Field Installed

O = Configure To Order (Factory Installed)

X = Field Installed

## OPTIONS / ACCESSORIES

Item Description	Model Number	Catalog Number	Unit Model No				
			156	180	210	240	300
<b>POWER EXHAUST</b>							
Standard Static	208/230V - C1PWRE11C-1Y	<b>75W90</b>	OX	OX	OX	OX	OX
	460V - C1PWRE11C-1G	<b>75W91</b>	OX	OX	OX	OX	OX
	575V - C1PWRE11C-1J	<b>75W92</b>	OX	OX	OX	OX	OX
SCCR, Standard Static	208/230V - C1PWRE11C-1Y	<b>75W90</b>	OX	OX	OX	OX	OX
	460V - C1PWRE11C-2G	<b>17J93</b>	OX	OX	OX	OX	OX
	575V - C1PWRE11C-2J	<b>17J98</b>	OX	OX	OX	OX	OX
<b>HUMIDITROL® CONDENSER REHEAT OPTION (CAV AND MSAV®) MODELS ONLY</b>							
Humiditrol® Dehumidification Option		Factory	O	O	O	O	O
Humidity Sensor Kit, Remote mounted (required)	C0SNSR31AE-1	<b>17M50</b>	X	X	X	X	X
<b>ROOF CURBS</b>							
<b>Hybrid Roof Curbs, Downflow</b>							
8 in. height	C1CURB70C-1	<b>11F58</b>	X	X	X	X	X
14 in. height	C1CURB71C-1	<b>11F59</b>	X	X	X	X	X
18 in. height	C1CURB72C-1	<b>11F60</b>	X	X	X	X	X
24 in. height	C1CURB73C-1	<b>11F61</b>	X	X	X	X	X
<b>Adjustable Pitch Curb</b>							
14 in. height	L1CURB55C	<b>43W26</b>	X	X	X	X	X
<b>Standard Roof Curbs, Horizontal - Requires Horizontal Return Air Panel Kit</b>							
26 in. height - slab applications	C1CURB14C-1	<b>11T89</b>	X	X	X	X	
30 in. height - slab applications	C1CURB15C-1	<b>11T90</b>					X
37 in. height - rooftop applications	C1CURB16C-1	<b>11T96</b>	X	X	X	X	
41 in. height - rooftop applications	C1CURB17C-1	<b>11T97</b>					X
<b>Insulation Kit For Standard Horizontal Roof Curbs</b>							
for C1CURB14C-1 (26 in.)	C1INSU11C-1-	<b>73K32</b>	X	X	X	X	
for C1CURB15C-1 (30 in.)	C1INSU12C-1-	<b>73K33</b>					X
for C1CURB16C-1 (37 in.)	C1INSU13C-1-	<b>73K34</b>	X	X	X	X	
for C1CURB17C-1 (41 in.)	C1INSU14C-1-	<b>73K35</b>					X
<b>Horizontal Return Air Panel Kit</b>							
Required for Horizontal Applications with Roof Curb	C1HRAP10C-1-	<b>87M00</b>	X	X	X	X	X
<b>CEILING DIFFUSERS</b>							
Step-Down - Order one	RTD11-185S	<b>13K63</b>	X	X			
	RTD11-275S	<b>13K64</b>			X	X	X
Flush - Order one	FD11-185S	<b>13K58</b>	X	X			
	FD11-275S	<b>13K59</b>			X	X	X
Transitions (Supply and Return) - Order one	C1DIFF33C-1	<b>12X68</b>	X	X			
	C1DIFF34C-1	<b>12X70</b>			X	X	X

<sup>1</sup> Order one 6 kW transformer per array (up to 24 solar modules each). Up to two arrays can be used per rooftop unit (total 48 modules). Arrays are field wired in parallel to the Solar Power Entry

NOTE - Catalog and model numbers shown are for ordering field installed accessories.

OX = Configure To Order (Factory Installed) or Field Installed

O = Configure To Order (Factory Installed)

X = Field Installed

## SPECIFICATIONS

General Data		Nominal Tonnage	13 Ton	13 Ton	13 Ton	
Model Number			LCH156H4B	LCH156H4V	LCH156H4M	
Efficiency Type			High	High	High	
Blower Type			CAV (Constant Air Volume)	VAV (Variable Air Volume)	MSAV® (Multi-Stage Air Volume)	
<b>Cooling Performance</b>	Gross Cooling Capacity - Btuh		154,000	152,000	154,000	
	<sup>1</sup> Net Cooling Capacity - Btuh		150,000	148,000	150,000	
	AHRI Rated Air Flow - cfm		5000	4600	5000	
	Total Unit Power - kW		12.5	12.3	12.5	
	<sup>1</sup> EER (Btuh/Watt)		12.0	12.0	12.0	
	<sup>2</sup> IEER (Btuh/Watt)		13.2	14.5	14.1	
<b>Refrigerant Charge</b>	Refrigerant Type		R-410A	R-410A	R-410A	
Environ™ Coil System	Circuit 1		5 lbs. 12 oz.	5 lbs. 0 oz.	5 lbs. 12 oz.	
		Circuit 2	5 lbs. 4 oz.	5 lbs. 8 oz.	5 lbs. 4 oz.	
		Circuit 3	5 lbs. 10 oz.	5 lbs. 0 oz.	5 lbs. 10 oz.	
	Environ™ Coil System with Humiditrol®	Circuit 1		5 lbs. 14 oz.	---	5 lbs. 14 oz.
		Circuit 2		5 lbs. 8 oz.	---	5 lbs. 8 oz.
		Circuit 3		5 lbs. 12 oz.	---	5 lbs. 12 oz.
	Conventional Fin/Tube Coil Option	Circuit 1		10 lbs. 0 oz.	---	10 lbs. 0 oz.
		Circuit 2		10 lbs. 0 oz.	---	10 lbs. 0 oz.
		Circuit 3		9 lbs. 8 oz.	---	9 lbs. 8 oz.
	Conventional Fin/Tube With Humiditrol®	Circuit 1		12 lbs. 0 oz.	---	12 lbs. 0 oz.
		Circuit 2		12 lbs. 0 oz.	---	12 lbs. 0 oz.
		Circuit 3		9 lbs. 8 oz.	---	9 lbs. 8 oz.
	<b>Electric Heat (kW) Available - See page 26</b>			15-30-45-60		
	<b>Compressor Type (number)</b>			Scroll (3)		
	<b>Outdoor Coils</b>	Net face area (total) - sq. ft.		41.4	41.4	41.4
Environ™ (Fin/Tube) Number of rows			1 (2)	1 (2)	1 (2)	
Fins per inch			23 (20)	23 (20)	23 (20)	
<b>Outdoor Coil Fans</b>	Motor - (No.) horsepower		(3) 1/3	(3) 1/3	(3) 1/3	
	Motor rpm		1075	1075	1075	
	Total Motor watts		1100	1100	1100	
	Diameter - (No.) in.		(3) 24	(3) 24	(3) 24	
	Number of blades		3	3	3	
	Total Air volume - cfm		12,000	12,000	12,000	
<b>Indoor Coils</b>	Net face area (total) - sq. ft.		21.4	21.4	21.4	
	Tube diameter - in.		3/8	3/8	3/8	
	Number of rows		3	3	3	
	Fins per inch		14	14	14	
	Drain connection - No. and size		(1) 1 in. FPT	(1) 1 in. FPT	(1) 1 in. FPT	
Expansion device type			Balance port TXV, removable head			
<b><sup>3</sup> Indoor Blower and Drive Selection</b>	Nominal motor output		2 hp, 3 hp, 5 hp			
	Max. usable motor output (US)		2.3 hp, 3.45 hp, 5.75 hp			
	Motor - Drive kit number		<b>2 hp</b> Kit 1 535-725 rpm Kit 2 710-965 rpm <b>3 hp Std. Eff.</b> Kit 1 535-725 rpm Kit 2 710-965 rpm <b>3 hp High. Eff.</b> Kit 3 685-856 rpm Kit 4 850-1045 rpm <b>5 hp</b> Kit 3 - 685-856 rpm Kit 4 850-1045 rpm Kit 5 945-1185 rpm			
	Blower wheel nominal D x W - in.		(2) 15 x 15 in.	(2) 15 x 15 in.	(2) 15 x 15 in.	
	<b>Filters</b>	Type of filter		Fiberglass, disposable		
		Number and size - in.		(6) 24 x 24 x 2		
	<b>Electrical characteristics</b>			208/230V, 460V or 575V - 60 hertz - 3 phase		

NOTE - Net capacity includes evaporator blower motor heat deduction. Gross capacity does not include evaporator blower motor heat deduction.

<sup>1</sup> AHRI Certified to AHRI Standard 340/360; 95°F outdoor air temperature and 80°F db/67°F wb entering evaporator air; minimum external duct static pressure.

<sup>2</sup> Integrated Energy Efficiency Ratio tested according to AHRI Standard 340/360.

<sup>3</sup> Using total air volume and system static pressure requirements determine from blower performance tables rpm and motor output required. Maximum usable output of motors furnished are shown. In Canada, nominal motor output is also maximum usable motor output. If motors of comparable output are used, be sure to keep within the service factor limitations outlined on the motor nameplate.

NOTE - Units equipped with MSAV® (Multi-Stage Air Volume) option are limited to a motor service factor of 1.0.

## SPECIFICATIONS

General Data		Nominal Tonnage	15 Ton	15 Ton	15 Ton	17.5 Ton	17.5 Ton	
		Model Number	LCH180H4B	LCH180H4V	LCH180H4M	LCH210H4B	LCH210H4M	
		Efficiency Type	High	High	High	High	High	
		Blower Type	CAV (Constant Air Volume)	VAV (Variable Air Volume)	MSAV® (Multi-Stage Air Volume)	CAV (Constant Air Volume)	MSAV® (Multi-Stage Air Volume)	
<b>Cooling Performance</b>	Gross Cooling Capacity - Btuh		176,000	176,000	176,000	204,000	204,000	
	<sup>1</sup> Net Cooling Capacity - Btuh		172,000	172,000	172,000	198,000	198,000	
	AHRI Rated Air Flow - cfm		5250	5250	5250	6125	6125	
	Total Unit Power - kW		14.3	14.3	14.3	16.5	16.5	
	<sup>1</sup> EER (Btuh/Watt)		12.0	12.0	12.0	12.0	12.0	
	<sup>2</sup> IEER (Btuh/Watt)		13.5	15.2	13.7	13.0	14.0	
<b>Refrigerant Charge</b>	Refrigerant Type		R-410A	R-410A	R-410A	R-410A	R-410A	
	Environ™ Coil System	Circuit 1	6 lbs. 0 oz.	5 lbs. 4 oz.	6 lbs. 0 oz.	6 lbs. 12 oz.	6 lbs. 12 oz.	
		Circuit 2	5 lbs. 10 oz.	5 lbs. 8 oz.	5 lbs. 10 oz.	6 lbs. 14 oz.	6 lbs. 14 oz.	
		Circuit 3	5 lbs. 14 oz.	5 lbs. 8 oz.	5 lbs. 14 oz.	6 lbs. 14 oz.	6 lbs. 14 oz.	
	Environ™ Coil System with Humiditrol®	Circuit 1	6 lbs. 8 oz.	---	6 lbs. 8 oz.	7 lbs. 4 oz.	7 lbs. 4 oz.	
		Circuit 2	5 lbs. 12 oz.	---	5 lbs. 12 oz.	7 lbs. 0 oz.	7 lbs. 0 oz.	
		Circuit 3	6 lbs. 9 oz.	---	6 lbs. 9 oz.	6 lbs. 4 oz.	6 lbs. 4 oz.	
	Conventional Fin/Tube Coil Option	Circuit 1	12 lbs. 8 oz.	---	12 lbs. 8 oz.	13 lbs. 0 oz.	13 lbs. 0 oz.	
		Circuit 2	12 lbs. 8 oz.	---	12 lbs. 8 oz.	13 lbs. 0 oz.	13 lbs. 0 oz.	
		Circuit 3	12 lbs. 8 oz.	---	12 lbs. 8 oz.	13 lbs. 0 oz.	13 lbs. 0 oz.	
	Conventional Fin/Tube With Humiditrol®	Circuit 1	14 lbs. 8 oz.	---	14 lbs. 8 oz.	15 lbs. 0 oz.	15 lbs. 0 oz.	
		Circuit 2	14 lbs. 8 oz.	---	14 lbs. 8 oz.	15 lbs. 0 oz.	15 lbs. 0 oz.	
		Circuit 3	12 lbs. 8 oz.	---	12 lbs. 8 oz.	13 lbs. 0 oz.	13 lbs. 0 oz.	
	<b>Electric Heat (kW) Available - See page 26</b>			15-30-45-60 kW			15-30-45-60-90 kW	
	<b>Compressor Type (number)</b>			Scroll (3)	Scroll (3)	Scroll (3)	Scroll (3)	Scroll (3)
	<b>Outdoor Coils</b>	Net face area (total) - sq. ft.		55.2	55.2	55.2	55.2	55.2
		Environ™ (Fin/Tube)	Number of rows	1 (2)	1 (2)	1 (2)	1 (2)	1 (2)
Fins per inch	23 (20)		23 (20)	23 (20)	23 (20)	23 (20)		
<b>Outdoor Coil Fans</b>	Motor - (No.) horsepower		(4) 1/3	(4) 1/3	(4) 1/3	(6) 1/3	(6) 1/3	
	Motor rpm		1075	1075	1075	1075	1075	
	Total Motor watts		1500	1500	1500	1950	1950	
	Diameter - (No.) in.		(4) 24	(4) 24	(4) 24	(6) 24	(6) 24	
	Number of blades		3	3	3	3	3	
	Total Air volume - cfm		16,000	16,000	16,000	20,000	20,000	
	Net face area (total) - sq. ft.		21.4	21.4	21.4	21.4	21.4	
<b>Indoor Coils</b>	Tube diameter - in.		3/8	3/8	3/8	3/8	3/8	
	Number of rows		3	3	3	4	4	
	Fins per inch		14	14	14	14	14	
	Drain connection - No. and size		(1) 1 in. FPT	(1) 1 in. FPT	(1) 1 in. FPT	(1) 1 in. FPT	(1) 1 in. FPT	
	Expansion device type		Balance port TXV, removable head					
<sup>3</sup> <b>Indoor Blower and Drive Selection</b>	Nominal motor output		3 hp, 5 hp, 7.5 hp					
	Max. usable motor output (US)		3.45 hp, 5.75 hp, 8.62 hp					
	Motor - Drive kit number		<b>3 hp Std. Eff.</b> Kit 1 535-725 rpm Kit 2 710-965 rpm <b>3 hp High. Eff.</b> Kit 3 - 685-856 rpm Kit 4 850-1045 rpm <b>5 hp</b> Kit 3 685-856 rpm Kit 4 850-1045 rpm Kit 5 945-1185 rpm <b>7.5 hp</b> Kit 6 850-1045 rpm Kit 7 945-1185 rpm Kit 8 1045-1285 rpm					
	Blower wheel nominal D x W - in.		(2) 15 x 15					
	<b>Filters</b>	Type of filter		Fiberglass, disposable				
		Number and size - in.		(6) 24 x 24 x 2				
	<b>Electrical characteristics</b>			208/230V, 460V or 575V - 60 hertz - 3 phase				

NOTE - Net capacity includes evaporator blower motor heat deduction. Gross capacity does not include evaporator blower motor heat deduction.

<sup>1</sup> AHRI Certified to AHRI Standard 340/360; 95°F outdoor air temperature and 80°F db/67°F wb entering evaporator air; minimum external duct static pressure.

<sup>2</sup> Integrated Energy Efficiency Ratio tested according to AHRI Standard 340/360.

<sup>3</sup> Using total air volume and system static pressure requirements determine from blower performance tables rpm and motor output required. Maximum usable output of motors furnished are shown. In Canada, nominal motor output is also maximum usable motor output. If motors of comparable output are used, be sure to keep within the service factor limitations outlined on the motor nameplate.

NOTE - Units equipped with MSAV® (Multi-Stage Air Volume) option are limited to a motor service factor of 1.0.



## SPECIFICATIONS

General Data		Nominal Tonnage	20 Ton	20 Ton	20 Ton
		Model Number	LCH240H4B	LCH240H4V	LCH240H4M
		Efficiency Type	High	High	High
		Blower Type	CAV (Constant Air Volume)	VAV (Variable Air Volume)	MSAV® (Multi-Stage Air Volume)
<b>Cooling Performance</b>	Gross Cooling Capacity - Btuh		238,000	238,000	238,000
	<sup>1</sup> Net Cooling Capacity - Btuh		230,000	230,000	230,000
	AHRI Rated Air Flow - cfm		6400	6400	6400
	Total Unit Power - kW		19.2	19.2	19.2
	<sup>1</sup> EER (Btuh/Watt)		12.0	12.0	12.0
	<sup>2</sup> IEER (Btuh/Watt)		13.2	16.0	14.5
<b>Refrigerant Charge</b>	Refrigerant Type		R-410A	R-410A	R-410A
	Environ™ Coil System	Circuit 1	6 lbs. 4 oz.	6 lbs. 2 oz.	6 lbs. 4 oz.
		Circuit 2	6 lbs. 2 oz.	6 lbs. 6 oz.	6 lbs. 2 oz.
		Circuit 3	5 lbs. 14 oz.	6 lbs. 0 oz.	5 lbs. 14 oz.
		Circuit 4	5 lbs. 6 oz.	6 lbs. 10 oz.	5 lbs. 6 oz.
	Environ™ Coil System with Humiditrol®	Circuit 1	6 lbs. 4 oz.	---	6 lbs. 4 oz.
		Circuit 2	5 lbs. 10 oz.	---	5 lbs. 10 oz.
		Circuit 3	4 lbs. 14 oz.	---	4 lbs. 14 oz.
		Circuit 4	4 lbs. 14 oz.	---	4 lbs. 14 oz.
	Conventional Fin/Tube Coil Option	Circuit 1	10 lbs. 0 oz.	---	10 lbs. 0 oz.
		Circuit 2	10 lbs. 0 oz.	---	10 lbs. 0 oz.
		Circuit 3	10 lbs. 0 oz.	---	10 lbs. 0 oz.
		Circuit 4	8 lbs. 12 oz.	---	8 lbs. 12 oz.
	Conventional Fin/Tube With Humiditrol®	Circuit 1	12 lbs. 0 oz.	---	12 lbs. 0 oz.
		Circuit 2	12 lbs. 0 oz.	---	12 lbs. 0 oz.
		Circuit 3	10 lbs. 0 oz.	---	10 lbs. 0 oz.
Circuit 4		8 lbs. 12 oz.	---	8 lbs. 12 oz.	
<b>Electric Heat (kW) Available - See page 26</b>			15-30-45-60, 90 kW		
<b>Compressor Type (number)</b>			Scroll (4)	Scroll (4)	Scroll (4)
<b>Outdoor Coils</b>	Net face area (total) - sq. ft.		55.2	55.2	55.2
	Environ™ (Fin/Tube)	Number of rows	1 (2)	1 (2)	1 (2)
Fins per inch		23 (20)	23 (20)	23 (20)	
<b>Outdoor Coil Fans</b>	Motor - (No.) horsepower		(6) 1/3	(6) 1/3	(6) 1/3
	Motor rpm -Total Motor watts		1075 - 1950	1075 - 1950	1075 - 1950
	Diameter - (No.) in. - No. of blades		(6) 24 - 3	(6) 24 - 3	(6) 24 - 3
	Total Air volume - cfm		20,000	20,000	20,000
<b>Indoor Coils</b>	Net face area (total) - sq. ft.		21.4	21.4	21.4
	Tube diameter - in.		3/8	3/8	3/8
	Number of rows		4	4	4
	Fins per inch		14	14	14
	Drain connection - No. and size		(1) 1 in. FPT	(1) 1 in. FPT	(1) 1 in. FPT
	Expansion device type		Balance port TXV, removable head		
<sup>3</sup> <b>Indoor Blower and Drive Selection</b>	Nominal motor output		5 hp, 7.5 hp, 10 hp		
	Maximum usable motor output (US Only)		5.75 hp, 8.62 hp, 11.5 hp		
	Motor - Drive kit number		<b>5 hp</b> <b>Kit 3</b> 685-856 rpm <b>Kit 4</b> 850-1045 rpm <b>Kit 5</b> 945-1185 rpm <b>7.5 hp</b> <b>Kit 6</b> 850-1045 rpm <b>Kit 7</b> 945-1185 rpm <b>Kit 8</b> 1045-1285 rpm <b>10 hp</b> <b>Kit 7</b> 945-1185 rpm <b>Kit 10</b> 1045-1285 rpm <b>Kit 11</b> 1135-1365 rpm		
Blower wheel nom. D x W - in.		(2) 15 x 15			
<b>Filters</b>	Type of filter		Fiberglass, disposable		
	Number and size - in.		(6) 24 x 24 x 2		
<b>Electrical characteristics</b>			208/230V, 460V or 575V - 60 hertz - 3 phase		

NOTE - Net capacity includes evaporator blower motor heat deduction. Gross capacity does not include evaporator blower motor heat deduction.

<sup>1</sup> AHRI Certified to AHRI Standard 340/360; 95°F outdoor air temperature and 80°F db/67°F wb entering evaporator air; minimum external duct static pressure.

<sup>2</sup> Integrated Energy Efficiency Ratio tested according to AHRI Standard 340/360.

<sup>3</sup> Using total air volume and system static pressure requirements determine from blower performance tables rpm and motor output required. Maximum usable output of motors furnished are shown. In Canada, nominal motor output is also maximum usable motor output. If motors of comparable output are used, be sure to keep within the service factor limitations outlined on the motor nameplate.

NOTE - Units equipped with MSAV® (Multi-Stage Air Volume) option are limited to a motor service factor of 1.0.



## SPECIFICATIONS

General Data		Nominal Tonnage	25 Ton	25 Ton
		Model Number	LCH300S4B	LCH300S4M
		Efficiency Type	Standard	Standard
		Blower Type	CAV (Constant Air Volume)	MSAV® (Multi-Stage Air Volume)
<b>Cooling Performance</b>	Gross Cooling Capacity - Btuh		281,000	281,000
	<sup>1</sup> Net Cooling Capacity - Btuh		270,000	270,000
	AHRI Rated Air Flow - cfm		8400	8400
	Total Unit Power - kW		25.7	25.7
	<sup>1</sup> EER (Btuh/Watt)		10.5	10.5
	<sup>2</sup> IEER (Btuh/Watt)		11.6	13.8
<b>Refrigerant Charge</b>	Refrigerant Type		R-410A	R-410A
	Environ™ Coil System	Circuit 1	6 lbs. 4 oz.	6 lbs. 4 oz.
		Circuit 2	5 lbs. 10 oz.	5 lbs. 10 oz.
		Circuit 3	6 lbs. 6 oz.	6 lbs. 6 oz.
		Circuit 4	6 lbs. 0 oz.	6 lbs. 0 oz.
	Environ™ Coil System with Humiditrol®	Circuit 1	7 lbs. 8 oz.	7 lbs. 8 oz.
		Circuit 2	6 lbs. 4 oz.	6 lbs. 4 oz.
		Circuit 3	6 lbs. 2 oz.	6 lbs. 2 oz.
		Circuit 4	5 lbs. 14 oz.	5 lbs. 14 oz.
	Conventional Fin/Tube Coil Option	Circuit 1	10 lbs. 8 oz.	10 lbs. 8 oz.
		Circuit 2	10 lbs. 0 oz.	10 lbs. 0 oz.
		Circuit 3	9 lbs. 12 oz.	9 lbs. 12 oz.
		Circuit 4	9 lbs. 12 oz.	9 lbs. 12 oz.
	Conventional Fin/Tube With Humiditrol®	Circuit 1	12 lbs. 12 oz.	12 lbs. 12 oz.
		Circuit 2	11 lbs. 12 oz.	11 lbs. 12 oz.
		Circuit 3	9 lbs. 12 oz.	9 lbs. 12 oz.
		Circuit 4	9 lbs. 12 oz.	9 lbs. 12 oz.
<b>Electric Heat (kW) Available - See page 26</b>			15-30-45-60, 90 kW	
<b>Compressor Type (number)</b>			Scroll (4)	Scroll (4)
<b>Outdoor Coils</b>	Net face area (total) - sq. ft.		55.2	55.2
	Environ™ (Fin/Tube)	Number of rows	1 (2)	1 (2)
		Fins per inch	23 (20)	23 (20)
<b>Outdoor Coil Fans</b>	Motor - (No.) horsepower		(6) 1/3	(6) 1/3
	Motor rpm - Total Motor watts		1075 - 1950	1075 - 1950
	Diameter - (No.) in. - No. of blades		(6) 24 - 3	(6) 24 - 3
	Total Air volume - cfm		20,000	20,000
<b>Indoor Coils</b>	Net face area (total) - sq. ft.		21.4	21.4
	Tube diameter - in.		3/8	3/8
	Number of rows		4	4
	Fins per inch		14	14
	Drain connection - No. and size		(1) 1 in. FPT	(1) 1 in. FPT
Expansion device type			Balance port TXV, removable head	
<sup>3</sup> <b>Indoor Blower and Drive Selection</b>	Nominal motor output		5 hp, 7.5 hp, 10 hp	
	Maximum usable motor output (US Only)		5.75 hp, 8.62 hp, 11.5 hp	
	Motor - Drive kit number		<b>5 hp</b> <b>Kit 3</b> 685-856 rpm <b>Kit 4</b> 850-1045 rpm <b>Kit 5</b> 945-1185 rpm <b>7.5 hp</b> <b>Kit 6</b> 850-1045 rpm <b>Kit 7</b> 945-1185 rpm <b>Kit 8</b> 1045-1285 rpm <b>10 hp</b> <b>Kit 7</b> 945-1185 rpm <b>Kit 10</b> 1045-1285 rpm <b>Kit 11</b> 1135-1365 rpm	
Blower wheel nom. D x W - in.		(2) 15 x 15		
<b>Filters</b>	Type of filter		Fiberglass, disposable	
	Number and size - in.		(6) 24 x 24 x 2	
<b>Electrical characteristics</b>			208/230V, 460V or 575V - 60 hertz - 3 phase	

NOTE - Net capacity includes evaporator blower motor heat deduction. Gross capacity does not include evaporator blower motor heat deduction.

<sup>1</sup> AHRI Certified to AHRI Standard 340/360; 95°F outdoor air temperature and 80°F db/67°F wb entering evaporator air; minimum external duct static pressure.

<sup>2</sup> Integrated Energy Efficiency Ratio tested according to AHRI Standard 340/360.

<sup>3</sup> Using total air volume and system static pressure requirements determine from blower performance tables rpm and motor output required. Maximum usable output of motors furnished are shown. In Canada, nominal motor output is also maximum usable motor output. If motors of comparable output are used, be sure to keep within the service factor limitations outlined on the motor nameplate.

NOTE - Units equipped with MSAV® (Multi-Stage Air Volume) option are limited to a motor service factor of 1.0.





# RATINGS

NOTE – For Temperatures and Capacities not shown in tables, see bulletin – Cooling Unit Rating Table Correction Factor Data in Miscellaneous Engineering Data section.

## 25 TON STANDARD EFFICIENCY LCH300S4B (1ST STAGE) - CONSTANT AIR VOLUME

Entering Wet Bulb Temperature	Total Air Volume	Outdoor Air Temperature Entering Outdoor Coil																			
		65°F					75°F					85°F					95°F				
		Total Cool Cap.	Comp. Motor Input	Sensible To Total Ratio (S/T)			Total Cool Cap.	Comp. Motor Input	Sensible To Total Ratio (S/T)			Total Cool Cap.	Comp. Motor Input	Sensible To Total Ratio (S/T)			Total Cool Cap.	Comp. Motor Input	Sensible To Total Ratio (S/T)		
				Dry Bulb					Dry Bulb					Dry Bulb					Dry Bulb		
		cfm	kBtuh	kW	75°F	80°F	85°F	kBtuh	kW	75°F	80°F	85°F	kBtuh	kW	75°F	80°F	85°F	kBtuh	kW	75°F	80°F
63°F	8000	147.3	6.36	0.70	0.82	0.95	140.6	7.18	0.71	0.84	0.97	134.8	8.10	0.72	0.86	0.99	129.1	9.16	0.73	0.88	1.00
	9500	152.7	6.41	0.73	0.87	0.99	145.9	7.24	0.74	0.90	1.00	140.0	8.16	0.75	0.92	1.00	133.8	9.22	0.77	0.94	1.00
	11000	157.6	6.47	0.75	0.92	1.00	150.5	7.29	0.78	0.95	1.00	144.1	8.22	0.80	0.97	1.00	137.6	9.27	0.82	0.98	1.00
67°F	8000	156.1	6.45	0.55	0.67	0.79	149.2	7.27	0.56	0.68	0.81	142.8	8.20	0.57	0.70	0.83	136.3	9.25	0.57	0.70	0.84
	9500	161.6	6.51	0.57	0.70	0.84	154.0	7.33	0.58	0.71	0.86	147.3	8.26	0.59	0.73	0.88	140.8	9.31	0.60	0.75	0.91
	11000	165.6	6.55	0.59	0.73	0.89	158.2	7.38	0.60	0.76	0.92	151.1	8.31	0.61	0.77	0.94	144.2	9.37	0.63	0.79	0.96
71°F	8000	165.2	6.55	0.42	0.54	0.65	157.7	7.38	0.42	0.54	0.66	151.1	8.31	0.42	0.55	0.67	144.2	9.37	0.43	0.56	0.69
	9500	170.7	6.61	0.43	0.56	0.68	162.8	7.44	0.43	0.57	0.70	155.4	8.37	0.44	0.57	0.71	148.2	9.42	0.44	0.58	0.72
	11000	174.8	6.66	0.44	0.58	0.71	166.6	7.49	0.45	0.59	0.73	159.1	8.42	0.44	0.60	0.75	151.8	9.47	0.45	0.61	0.77

## 25 TON STANDARD EFFICIENCY LCH300S4B (2ND STAGE) - CONSTANT AIR VOLUME

Entering Wet Bulb Temperature	Total Air Volume	Outdoor Air Temperature Entering Outdoor Coil																			
		85°F					95°F					105°F					115°F				
		Total Cool Cap.	Comp. Motor Input	Sensible To Total Ratio (S/T)			Total Cool Cap.	Comp. Motor Input	Sensible To Total Ratio (S/T)			Total Cool Cap.	Comp. Motor Input	Sensible To Total Ratio (S/T)			Total Cool Cap.	Comp. Motor Input	Sensible To Total Ratio (S/T)		
				Dry Bulb					Dry Bulb					Dry Bulb					Dry Bulb		
		cfm	kBtuh	kW	75°F	80°F	85°F	kBtuh	kW	75°F	80°F	85°F	kBtuh	kW	75°F	80°F	85°F	kBtuh	kW	75°F	80°F
63°F	8000	277.2	17.80	0.72	0.87	1.00	264.6	19.95	0.74	0.89	1.00	251.7	22.43	0.75	0.92	1.00	238.5	25.35	0.78	0.95	1.00
	9500	287.2	17.97	0.76	0.93	1.00	273.8	20.12	0.78	0.96	1.00	260.1	22.59	0.80	0.98	1.00	246.0	25.49	0.83	1.00	1.00
	11000	295.0	18.11	0.80	0.98	1.00	280.6	20.25	0.83	1.00	1.00	267.4	22.73	0.85	1.00	1.00	254.5	25.68	0.88	1.00	1.00
67°F	8000	293.2	18.08	0.57	0.70	0.83	279.6	20.23	0.58	0.71	0.86	265.8	22.71	0.59	0.73	0.88	251.7	25.63	0.60	0.75	0.91
	9500	302.9	18.25	0.59	0.74	0.89	288.4	20.39	0.60	0.76	0.92	273.9	22.86	0.62	0.78	0.95	258.8	25.78	0.63	0.80	0.98
	11000	310.1	18.38	0.62	0.78	0.95	295.3	20.52	0.63	0.80	0.98	279.9	22.99	0.64	0.83	1.00	264.5	25.89	0.65	0.85	1.00
71°F	8000	310.0	18.38	0.43	0.56	0.68	295.5	20.53	0.43	0.57	0.69	280.6	23.00	0.43	0.58	0.71	265.8	25.92	0.44	0.59	0.73
	9500	319.0	18.54	0.44	0.58	0.72	304.0	20.68	0.44	0.59	0.74	288.9	23.17	0.45	0.61	0.75	273.0	26.07	0.45	0.62	0.78
	11000	326.9	18.68	0.44	0.61	0.76	311.2	20.82	0.45	0.62	0.78	294.9	23.29	0.46	0.63	0.80	278.5	26.19	0.47	0.65	0.83

# RATINGS

NOTE – For Temperatures and Capacities not shown in tables, see bulletin – Cooling Unit Rating Table Correction Factor Data in Miscellaneous Engineering Data section.

## 13 TON HIGH EFFICIENCY LCH156H4V (1 COMPRESSOR OPERATING) - VARIABLE AIR VOLUME

Entering Wet Bulb Temperature	Total Air Volume	Outdoor Air Temperature Entering Outdoor Coil																							
		65°F						75°F						85°F						95°F					
		Total Cool Cap.	Comp. Motor Input	Sensible To Total Ratio (S/T)			Total Cool Cap.	Comp. Motor Input	Sensible To Total Ratio (S/T)			Total Cool Cap.	Comp. Motor Input	Sensible To Total Ratio (S/T)			Total Cool Cap.	Comp. Motor Input	Sensible To Total Ratio (S/T)						
				Dry Bulb					Dry Bulb					Dry Bulb					Dry Bulb						
cfm	kBtuh	kW	75°F	80°F	85°F	kBtuh	kW	75°F	80°F	85°F	kBtuh	kW	75°F	80°F	85°F	kBtuh	kW	75°F	80°F	85°F					
63°F	1500	51.8	2.25	0.74	0.87	0.96	49.5	2.58	0.74	0.88	0.96	46.9	2.93	0.75	0.89	0.97	44.3	3.33	0.76	0.9	0.98				
	1800	54.2	2.25	0.77	0.9	0.98	51.7	2.59	0.78	0.91	0.99	49.1	2.95	0.79	0.92	1	46.3	3.34	0.79	0.93	1				
	2100	56.1	2.26	0.8	0.93	1	53.5	2.6	0.8	0.94	1	50.8	2.96	0.81	0.95	1	47.9	3.35	0.83	0.96	1				
67°F	1500	54.3	2.25	0.49	0.69	0.83	51.9	2.59	0.49	0.69	0.84	49.4	2.95	0.48	0.7	0.85	46.6	3.34	0.48	0.71	0.87				
	1800	56.8	2.26	0.51	0.73	0.87	54.2	2.6	0.51	0.73	0.88	51.4	2.96	0.5	0.75	0.89	48.5	3.35	0.51	0.76	0.9				
	2100	58.7	2.27	0.53	0.76	0.9	56	2.61	0.53	0.77	0.91	53.2	2.97	0.53	0.78	0.92	50.2	3.36	0.53	0.79	0.94				
71°F	1500	57.1	2.26	0.25	0.45	0.64	54.5	2.6	0.24	0.45	0.64	51.9	2.96	0.22	0.44	0.65	49	3.36	0.21	0.44	0.66				
	1800	59.5	2.27	0.24	0.47	0.68	56.9	2.61	0.23	0.47	0.68	54	2.97	0.22	0.47	0.69	51.1	3.37	0.21	0.47	0.72				
	2100	61.4	2.28	0.24	0.49	0.71	58.7	2.62	0.23	0.49	0.73	55.7	2.98	0.22	0.5	0.74	52.6	3.38	0.21	0.5	0.76				

## 13 TON HIGH EFFICIENCY LCH156H4V (2 COMPRESSORS OPERATING) - VARIABLE AIR VOLUME

Entering Wet Bulb Temperature	Total Air Volume	Outdoor Air Temperature Entering Outdoor Coil																							
		65°F						75°F						85°F						95°F					
		Total Cool Cap.	Comp. Motor Input	Sensible To Total Ratio (S/T)			Total Cool Cap.	Comp. Motor Input	Sensible To Total Ratio (S/T)			Total Cool Cap.	Comp. Motor Input	Sensible To Total Ratio (S/T)			Total Cool Cap.	Comp. Motor Input	Sensible To Total Ratio (S/T)						
				Dry Bulb					Dry Bulb					Dry Bulb					Dry Bulb						
cfm	kBtuh	kW	75°F	80°F	85°F	kBtuh	kW	75°F	80°F	85°F	kBtuh	kW	75°F	80°F	85°F	kBtuh	kW	75°F	80°F	85°F					
63°F	3000	108.4	4.56	0.72	0.85	0.96	103.3	5.23	0.72	0.86	0.98	97.8	5.95	0.73	0.88	0.99	91.9	6.75	0.74	0.89	0.99				
	3500	112.5	4.58	0.75	0.89	0.99	107	5.25	0.75	0.9	1	101	5.97	0.76	0.92	1	95.2	6.77	0.78	0.94	1				
	4000	115.7	4.6	0.77	0.93	1	110.2	5.26	0.79	0.94	1	104.5	5.99	0.8	0.96	1	98.5	6.79	0.81	0.98	1				
67°F	3000	114.4	4.59	0.57	0.7	0.82	109.1	5.26	0.57	0.7	0.83	103.6	5.98	0.58	0.71	0.84	97.6	6.78	0.58	0.72	0.86				
	3500	119	4.61	0.59	0.73	0.86	113.4	5.28	0.59	0.74	0.87	107.5	6.01	0.6	0.75	0.89	101.2	6.81	0.6	0.76	0.91				
	4000	122.6	4.63	0.61	0.75	0.9	116.8	5.3	0.61	0.76	0.92	110.6	6.03	0.62	0.78	0.93	104	6.83	0.62	0.8	0.95				
71°F	3000	120	4.61	0.44	0.56	0.68	114.6	5.29	0.43	0.56	0.68	108.9	6.01	0.43	0.56	0.69	102.7	6.82	0.42	0.57	0.7				
	3500	125	4.64	0.44	0.58	0.7	119.1	5.31	0.44	0.58	0.71	113	6.04	0.44	0.58	0.72	106.7	6.85	0.44	0.59	0.74				
	4000	128.8	4.65	0.45	0.59	0.73	122.8	5.33	0.45	0.6	0.74	116.4	6.06	0.45	0.61	0.76	109.7	6.86	0.45	0.62	0.77				

## 13 TON HIGH EFFICIENCY LCH156H4V (3 COMPRESSORS OPERATING) - VARIABLE AIR VOLUME

Entering Wet Bulb Temperature	Total Air Volume	Outdoor Air Temperature Entering Outdoor Coil																							
		85°F						95°F						105°F						115°F					
		Total Cool Cap.	Comp. Motor Input	Sensible To Total Ratio (S/T)			Total Cool Cap.	Comp. Motor Input	Sensible To Total Ratio (S/T)			Total Cool Cap.	Comp. Motor Input	Sensible To Total Ratio (S/T)			Total Cool Cap.	Comp. Motor Input	Sensible To Total Ratio (S/T)						
				Dry Bulb					Dry Bulb					Dry Bulb					Dry Bulb						
cfm	kBtuh	kW	75°F	80°F	85°F	kBtuh	kW	75°F	80°F	85°F	kBtuh	kW	75°F	80°F	85°F	kBtuh	kW	75°F	80°F	85°F					
63°F	4160	151.8	9.02	0.72	0.84	0.95	143.1	10.22	0.72	0.85	0.97	133.7	11.57	0.74	0.87	0.99	123.6	13.1	0.75	0.89	1				
	5200	159.9	9.07	0.77	0.9	1	150.4	10.28	0.78	0.92	1	140.4	11.62	0.79	0.94	1	130.1	13.15	0.81	0.97	1				
	6240	166	9.1	0.81	0.96	1	156.6	10.32	0.83	0.98	1	146.6	11.67	0.84	0.99	1	136.2	13.2	0.87	1	1				
67°F	4160	158.6	9.05	0.56	0.7	0.81	149.2	10.26	0.56	0.71	0.82	139.5	11.61	0.57	0.71	0.84	129.3	13.15	0.58	0.73	0.86				
	5200	166.6	9.1	0.59	0.74	0.87	157.1	10.32	0.59	0.75	0.89	146.9	11.67	0.62	0.77	0.91	135.9	13.2	0.63	0.79	0.94				
	6240	172.9	9.14	0.62	0.79	0.93	162.9	10.36	0.64	0.8	0.95	152.2	11.71	0.64	0.82	0.98	140.6	13.24	0.66	0.84	0.99				
71°F	4160	167.9	9.11	0.42	0.55	0.68	158.5	10.33	0.42	0.56	0.68	147.9	11.68	0.41	0.55	0.7	136.8	13.2	0.41	0.56	0.71				
	5200	175.8	9.16	0.44	0.59	0.72	165.6	10.37	0.44	0.59	0.74	154.7	11.73	0.43	0.6	0.76	142.8	13.25	0.43	0.61	0.77				
	6240	181.9	9.2	0.46	0.62	0.77	170.8	10.41	0.46	0.63	0.79	159.5	11.77	0.45	0.64	0.81	147.1	13.29	0.45	0.65	0.83				

# RATINGS

NOTE – For Temperatures and Capacities not shown in tables, see bulletin – Cooling Unit Rating Table Correction Factor Data in Miscellaneous Engineering Data section.

## 15 TON HIGH EFFICIENCY LCH180H4V (1 COMPRESSOR OPERATING) - VARIABLE AIR VOLUME

Entering Wet Bulb Temperature	Total Air Volume	Outdoor Air Temperature Entering Outdoor Coil																			
		65°F					75°F					85°F					95°F				
		Total Cool Cap.	Comp. Motor Input	Sensible To Total Ratio (S/T)			Total Cool Cap.	Comp. Motor Input	Sensible To Total Ratio (S/T)			Total Cool Cap.	Comp. Motor Input	Sensible To Total Ratio (S/T)			Total Cool Cap.	Comp. Motor Input	Sensible To Total Ratio (S/T)		
				Dry Bulb					Dry Bulb					Dry Bulb					Dry Bulb		
cfm	kBtuh	kW	75°F	80°F	85°F	kBtuh	kW	75°F	80°F	85°F	kBtuh	kW	75°F	80°F	85°F	kBtuh	kW	75°F	80°F	85°F	
63°F	1600	58.6	2.51	0.58	0.73	0.87	55.8	2.87	0.59	0.74	0.89	52.7	3.25	0.59	0.75	0.9	49.5	3.67	0.59	0.77	0.93
	2000	62.3	2.53	0.62	0.78	0.93	59.2	2.89	0.62	0.79	0.95	55.9	3.27	0.63	0.81	0.97	52.4	3.68	0.64	0.83	0.99
	2400	65	2.55	0.64	0.83	0.98	61.7	2.9	0.65	0.85	0.99	58.3	3.28	0.67	0.87	1	54.7	3.7	0.68	0.89	1
67°F	1600	61.7	2.53	0.39	0.54	0.68	58.7	2.88	0.39	0.55	0.69	55.6	3.26	0.38	0.55	0.7	52.2	3.68	0.37	0.55	0.72
	2000	65.3	2.55	0.4	0.58	0.73	62.1	2.91	0.4	0.58	0.75	58.8	3.28	0.4	0.59	0.77	55.2	3.7	0.39	0.6	0.78
	2400	68.1	2.57	0.42	0.61	0.78	64.7	2.92	0.42	0.62	0.8	61.2	3.3	0.42	0.63	0.82	57.4	3.71	0.42	0.64	0.84
71°F	1600	64.9	2.55	0.2	0.36	0.5	61.8	2.9	0.19	0.35	0.5	58.6	3.28	0.18	0.35	0.51	55.2	3.7	0.16	0.34	0.51
	2000	68.5	2.57	0.2	0.37	0.53	65.3	2.92	0.18	0.37	0.54	61.9	3.3	0.17	0.37	0.54	58.2	3.71	0.16	0.36	0.56
	2400	71.3	2.59	0.19	0.39	0.57	67.9	2.94	0.19	0.39	0.58	64.3	3.32	0.17	0.39	0.59	60.5	3.73	0.16	0.39	0.61

## 15 TON HIGH EFFICIENCY LCH180H4V (2 COMPRESSORS OPERATING) - VARIABLE AIR VOLUME

Entering Wet Bulb Temperature	Total Air Volume	Outdoor Air Temperature Entering Outdoor Coil																			
		65°F					75°F					85°F					95°F				
		Total Cool Cap.	Comp. Motor Input	Sensible To Total Ratio (S/T)			Total Cool Cap.	Comp. Motor Input	Sensible To Total Ratio (S/T)			Total Cool Cap.	Comp. Motor Input	Sensible To Total Ratio (S/T)			Total Cool Cap.	Comp. Motor Input	Sensible To Total Ratio (S/T)		
				Dry Bulb					Dry Bulb					Dry Bulb					Dry Bulb		
cfm	kBtuh	kW	75°F	80°F	85°F	kBtuh	kW	75°F	80°F	85°F	kBtuh	kW	75°F	80°F	85°F	kBtuh	kW	75°F	80°F	85°F	
63°F	3200	124.3	5.08	0.7	0.82	0.94	117.9	5.79	0.71	0.83	0.95	111.2	6.55	0.71	0.85	0.97	104.2	7.38	0.72	0.86	0.98
	4000	131.8	5.13	0.74	0.87	0.99	125	5.83	0.75	0.89	0.99	117.8	6.59	0.76	0.91	1	110.2	7.42	0.77	0.93	1
	4800	137.2	5.16	0.78	0.93	1	130.1	5.86	0.79	0.94	1	122.9	6.62	0.8	0.96	1	115.5	7.45	0.81	0.98	1
67°F	3200	131.5	5.13	0.56	0.68	0.79	124.9	5.83	0.56	0.68	0.8	118.2	6.59	0.56	0.69	0.81	111.1	7.42	0.56	0.7	0.83
	4000	139.8	5.18	0.58	0.72	0.84	132.7	5.88	0.59	0.73	0.86	125.3	6.63	0.59	0.74	0.88	117.7	7.47	0.59	0.75	0.9
	4800	145.6	5.22	0.61	0.76	0.9	138.3	5.92	0.61	0.77	0.91	130.6	6.67	0.62	0.78	0.93	122.5	7.5	0.62	0.8	0.96
71°F	3200	138	5.16	0.43	0.55	0.66	131.5	5.87	0.43	0.55	0.66	124.5	6.63	0.42	0.55	0.67	117.2	7.46	0.42	0.55	0.68
	4000	146.8	5.22	0.44	0.57	0.69	139.7	5.93	0.43	0.58	0.71	132.2	6.68	0.44	0.58	0.72	124.3	7.51	0.43	0.58	0.73
	4800	153.2	5.27	0.45	0.6	0.73	145.7	5.97	0.45	0.6	0.75	137.9	6.72	0.44	0.61	0.76	129.7	7.55	0.44	0.61	0.77

## 15 TON HIGH EFFICIENCY LCH180H4V (3 COMPRESSORS OPERATING) - VARIABLE AIR VOLUME

Entering Wet Bulb Temperature	Total Air Volume	Outdoor Air Temperature Entering Outdoor Coil																			
		85°F					95°F					105°F					115°F				
		Total Cool Cap.	Comp. Motor Input	Sensible To Total Ratio (S/T)			Total Cool Cap.	Comp. Motor Input	Sensible To Total Ratio (S/T)			Total Cool Cap.	Comp. Motor Input	Sensible To Total Ratio (S/T)			Total Cool Cap.	Comp. Motor Input	Sensible To Total Ratio (S/T)		
				Dry Bulb					Dry Bulb					Dry Bulb					Dry Bulb		
cfm	kBtuh	kW	75°F	80°F	85°F	kBtuh	kW	75°F	80°F	85°F	kBtuh	kW	75°F	80°F	85°F	kBtuh	kW	75°F	80°F	85°F	
63°F	4800	176.3	9.9	0.72	0.83	0.95	165.8	11.16	0.72	0.85	0.96	154.7	12.56	0.73	0.86	0.98	142.9	14.15	0.74	0.88	0.99
	6000	186.7	9.96	0.76	0.89	0.99	175.2	11.21	0.77	0.91	1	163.4	12.62	0.79	0.93	1	151.1	14.22	0.8	0.96	1
	7200	193.9	10.01	0.8	0.95	1	182.5	11.26	0.82	0.97	1	170.8	12.67	0.83	0.99	1	158.6	14.27	0.86	1	1
67°F	4800	185.5	9.96	0.55	0.69	0.8	174.1	11.2	0.55	0.7	0.82	162.3	12.61	0.57	0.71	0.83	150	14.21	0.57	0.73	0.85
	6000	195.1	10.01	0.59	0.74	0.86	183.2	11.26	0.6	0.74	0.88	171.2	12.67	0.59	0.76	0.9	158.6	14.26	0.61	0.78	0.93
	7200	202.7	10.06	0.62	0.78	0.92	190.7	11.32	0.62	0.79	0.94	178.1	12.72	0.64	0.81	0.96	164.7	14.3	0.64	0.83	0.99
71°F	4800	197	10.03	0.42	0.55	0.67	185.4	11.28	0.42	0.54	0.67	173.3	12.68	0.42	0.54	0.69	160.4	14.27	0.41	0.55	0.7
	6000	207.2	10.09	0.43	0.57	0.71	194.6	11.34	0.44	0.59	0.73	181.8	12.74	0.43	0.6	0.74	168.5	14.34	0.43	0.6	0.76
	7200	214.6	10.14	0.45	0.6	0.76	201.4	11.39	0.46	0.62	0.78	188.3	12.79	0.45	0.62	0.79	174.1	14.38	0.44	0.64	0.81









# RATINGS

NOTE – For Temperatures and Capacities not shown in tables, see bulletin – Cooling Unit Rating Table Correction Factor Data in Miscellaneous Engineering Data section.

## 25 TON STANDARD EFFICIENCY LCH300S4M (1ST STAGE) - MSAV® (Multi-Stage Air Volume) SUPPLY AIR BLOWER

Entering Wet Bulb Temperature	Total Air Volume	Outdoor Air Temperature Entering Outdoor Coil																							
		65°F						75°F						85°F						95°F					
		Total Cool Cap.	Comp. Motor Input	Sensible To Total Ratio (S/T)			Total Cool Cap.	Comp. Motor Input	Sensible To Total Ratio (S/T)			Total Cool Cap.	Comp. Motor Input	Sensible To Total Ratio (S/T)			Total Cool Cap.	Comp. Motor Input	Sensible To Total Ratio (S/T)						
				Dry Bulb					Dry Bulb					Dry Bulb					Dry Bulb						
cfm	kBtuh	kW	75°F	80°F	85°F	kBtuh	kW	75°F	80°F	85°F	kBtuh	kW	75°F	80°F	85°F	kBtuh	kW	75°F	80°F	85°F					
63°F	5750	135.3	6.25	0.65	0.75	0.86	130.0	7.06	0.66	0.77	0.88	124.8	7.98	0.66	0.78	0.89	119.7	9.04	0.67	0.79	0.91				
	6750	141.3	6.30	0.67	0.79	0.90	135.5	7.12	0.68	0.80	0.92	129.8	8.04	0.69	0.82	0.94	124.3	9.10	0.70	0.83	0.96				
	7750	146.0	6.35	0.69	0.82	0.94	139.8	7.17	0.70	0.84	0.96	133.9	8.09	0.72	0.86	0.98	128.1	9.14	0.73	0.87	0.99				
67°F	5750	143.5	6.32	0.53	0.62	0.72	138.1	7.15	0.53	0.63	0.73	132.4	8.07	0.54	0.64	0.74	126.9	9.13	0.54	0.65	0.76				
	6750	149.9	6.39	0.54	0.64	0.75	143.6	7.21	0.54	0.65	0.77	137.7	8.14	0.55	0.67	0.78	131.9	9.19	0.56	0.67	0.80				
	7750	155.1	6.44	0.55	0.67	0.79	148.1	7.26	0.56	0.68	0.81	141.9	8.19	0.57	0.69	0.82	135.7	9.25	0.57	0.71	0.84				
71°F	5750	151.7	6.41	0.42	0.51	0.60	145.6	7.24	0.42	0.51	0.61	140.1	8.17	0.42	0.52	0.61	134.2	9.23	0.42	0.52	0.62				
	6750	158.3	6.48	0.42	0.52	0.62	151.7	7.31	0.42	0.53	0.63	145.6	8.24	0.42	0.53	0.64	139.7	9.30	0.42	0.54	0.65				
	7750	164.2	6.54	0.42	0.54	0.64	156.7	7.37	0.41	0.54	0.65	150.2	8.30	0.42	0.55	0.67	143.3	9.35	0.43	0.56	0.68				

## 25 TON STANDARD EFFICIENCY LCH300S4M (2ND STAGE) - MSAV® (Multi-Stage Air Volume) SUPPLY AIR BLOWER

Entering Wet Bulb Temperature	Total Air Volume	Outdoor Air Temperature Entering Outdoor Coil																							
		85°F						95°F						105°F						115°F					
		Total Cool Cap.	Comp. Motor Input	Sensible To Total Ratio (S/T)			Total Cool Cap.	Comp. Motor Input	Sensible To Total Ratio (S/T)			Total Cool Cap.	Comp. Motor Input	Sensible To Total Ratio (S/T)			Total Cool Cap.	Comp. Motor Input	Sensible To Total Ratio (S/T)						
				Dry Bulb					Dry Bulb					Dry Bulb					Dry Bulb						
cfm	kBtuh	kW	75°F	80°F	85°F	kBtuh	kW	75°F	80°F	85°F	kBtuh	kW	75°F	80°F	85°F	kBtuh	kW	75°F	80°F	85°F					
63°F	8000	277.2	17.80	0.72	0.87	1.00	264.6	19.95	0.74	0.89	1.00	251.7	22.43	0.75	0.92	1.00	238.5	25.35	0.78	0.95	1.00				
	9500	287.2	17.97	0.76	0.93	1.00	273.8	20.12	0.78	0.96	1.00	260.1	22.59	0.80	0.98	1.00	246.0	25.49	0.83	1.00	1.00				
	11000	295.0	18.11	0.80	0.98	1.00	280.6	20.25	0.83	1.00	1.00	267.4	22.73	0.85	1.00	1.00	254.5	25.68	0.88	1.00	1.00				
67°F	8000	293.2	18.08	0.57	0.70	0.83	279.6	20.23	0.58	0.71	0.86	265.8	22.71	0.59	0.73	0.88	251.7	25.63	0.60	0.75	0.91				
	9500	302.9	18.25	0.59	0.74	0.89	288.4	20.39	0.60	0.76	0.92	273.9	22.86	0.62	0.78	0.95	258.8	25.78	0.63	0.80	0.98				
	11000	310.1	18.38	0.62	0.78	0.95	295.3	20.52	0.63	0.80	0.98	279.9	22.99	0.64	0.83	1.00	264.5	25.89	0.65	0.85	1.00				
71°F	8000	310.0	18.38	0.43	0.56	0.68	295.5	20.53	0.43	0.57	0.69	280.6	23.00	0.43	0.58	0.71	265.8	25.92	0.44	0.59	0.73				
	9500	319.0	18.54	0.44	0.58	0.72	304.0	20.68	0.44	0.59	0.74	288.9	23.17	0.45	0.61	0.75	273.0	26.07	0.45	0.62	0.78				
	11000	326.9	18.68	0.44	0.61	0.76	311.2	20.82	0.45	0.62	0.78	294.9	23.29	0.46	0.63	0.80	278.5	26.19	0.47	0.65	0.83				

# HUMIDITROL® DEHUMIDIFICATION SYSTEM RATINGS

## 13 TON HIGH EFFICIENCY LCH156H4B WITH HUMIDITROL® OPERATING (1ST STAGE) - CONSTANT AIR VOLUME

Entering Wet Bulb Temperature	Total Air Volume	Outdoor Air Temperature Entering Outdoor Coil																			
		65°F					75°F					85°F					95°F				
		Total Cool Cap.	Comp. Motor Input	Sensible To Total Ratio (S/T)			Total Cool Cap.	Comp. Motor Input	Sensible To Total Ratio (S/T)			Total Cool Cap.	Comp. Motor Input	Sensible To Total Ratio (S/T)			Total Cool Cap.	Comp. Motor Input	Sensible To Total Ratio (S/T)		
				Dry Bulb					Dry Bulb					Dry Bulb					Dry Bulb		
cfm	kBtuh	kW	75°F	80°F	85°F	kBtuh	kW	75°F	80°F	85°F	kBtuh	kW	75°F	80°F	85°F	kBtuh	kW	75°F	80°F	85°F	
63°F	4160	78.9	4.67	.56	.74	.93	66.3	5.28	.50	.73	.96	53.6	5.89	.45	.72	.99	40.9	6.50	.39	.71	1.00
	5200	86.8	4.71	.58	.80	1.00	72.5	5.30	.52	.79	1.00	58.1	5.89	.47	.78	1.00	43.7	6.48	.41	.77	1.00
	6240	94.7	4.74	.60	.86	1.00	78.7	5.32	.54	.85	1.00	62.6	5.89	.49	.83	1.00	46.6	6.47	.43	.82	1.00
67°F	4160	89.4	4.76	.40	.57	.74	77.1	5.37	.33	.53	.74	64.8	5.98	.26	.49	.73	52.5	6.59	.18	.46	.73
	5200	97.5	4.77	.41	.61	.80	83.6	5.38	.34	.57	.80	69.6	5.98	.26	.53	.80	55.7	6.58	.18	.49	.81
	6240	105.7	4.79	.43	.64	.86	90.1	5.38	.34	.60	.87	74.5	5.98	.26	.57	.88	58.9	6.57	.17	.53	.89
71°F	4160	99.9	4.85	.25	.40	.55	87.9	5.46	.16	.33	.51	76.0	6.07	.07	.27	.47	64.1	6.69	-.03	.20	.43
	5200	108.2	4.84	.25	.41	.58	94.7	5.45	.15	.35	.55	81.2	6.07	.05	.28	.52	67.7	6.68	-.06	.22	.49
	6240	116.6	4.84	.25	.43	.61	101.5	5.45	.14	.36	.59	86.4	6.06	.03	.30	.57	71.3	6.68	-.09	.23	.55

## 13 TON HIGH EFFICIENCY LCH156H4B WITH HUMIDITROL® OPERATING (2ND STAGE) - CONSTANT AIR VOLUME

Entering Wet Bulb Temperature	Total Air Volume	Outdoor Air Temperature Entering Outdoor Coil																			
		65°F					75°F					85°F					95°F				
		Total Cool Cap.	Comp. Motor Input	Sensible To Total Ratio (S/T)			Total Cool Cap.	Comp. Motor Input	Sensible To Total Ratio (S/T)			Total Cool Cap.	Comp. Motor Input	Sensible To Total Ratio (S/T)			Total Cool Cap.	Comp. Motor Input	Sensible To Total Ratio (S/T)		
				Dry Bulb					Dry Bulb					Dry Bulb					Dry Bulb		
cfm	kBtuh	kW	75°F	80°F	85°F	kBtuh	kW	75°F	80°F	85°F	kBtuh	kW	75°F	80°F	85°F	kBtuh	kW	75°F	80°F	85°F	
63°F	4160	131.1	7.12	.64	.82	1.00	116.4	8.10	.62	.83	1.00	101.6	9.08	.60	.84	1.00	86.8	10.05	.57	.85	1.00
	5200	142.5	7.16	.67	.87	1.00	125.8	8.14	.66	.89	1.00	109.2	9.11	.65	.90	1.00	92.6	10.09	.64	.91	1.00
	6240	153.8	7.20	.71	.93	1.00	135.3	8.17	.71	.94	1.00	116.8	9.15	.71	.96	1.00	98.3	10.12	.71	.98	1.00
67°F	4160	148.3	7.23	.47	.63	.79	132.8	8.20	.44	.62	.81	117.3	9.18	.41	.61	.82	101.8	10.15	.37	.61	.84
	5200	160.5	7.28	.49	.67	.85	143.0	8.25	.46	.67	.87	125.4	9.22	.44	.66	.88	107.8	10.19	.41	.65	.90
	6240	172.8	7.33	.51	.71	.91	153.1	8.30	.49	.71	.92	133.5	9.26	.47	.70	.94	113.8	10.23	.44	.70	.96
71°F	4160	165.4	7.34	.31	.45	.59	149.2	8.31	.26	.42	.58	133.0	9.28	.22	.39	.57	116.8	10.24	.17	.36	.56
	5200	178.6	7.40	.31	.47	.63	160.1	8.37	.27	.44	.62	141.6	9.33	.22	.42	.62	123.0	10.29	.17	.39	.62
	6240	191.8	7.46	.32	.49	.67	171.0	8.42	.27	.47	.67	150.1	9.38	.22	.45	.67	129.2	10.34	.17	.42	.68

## 15 TON HIGH EFFICIENCY LCH180H4B WITH HUMIDITROL® OPERATING (1ST STAGE) - CONSTANT AIR VOLUME

Entering Wet Bulb Temperature	Total Air Volume	Outdoor Air Temperature Entering Outdoor Coil																			
		65°F					75°F					85°F					95°F				
		Total Cool Cap.	Comp. Motor Input	Sensible To Total Ratio (S/T)			Total Cool Cap.	Comp. Motor Input	Sensible To Total Ratio (S/T)			Total Cool Cap.	Comp. Motor Input	Sensible To Total Ratio (S/T)			Total Cool Cap.	Comp. Motor Input	Sensible To Total Ratio (S/T)		
				Dry Bulb					Dry Bulb					Dry Bulb					Dry Bulb		
cfm	kBtuh	kW	75°F	80°F	85°F	kBtuh	kW	75°F	80°F	85°F	kBtuh	kW	75°F	80°F	85°F	kBtuh	kW	75°F	80°F	85°F	
63°F	4800	91.6	5.36	.56	.74	.91	78.7	6.02	.51	.73	.94	65.8	6.67	.46	.71	.96	52.8	7.33	.41	.70	.98
	6000	97.3	5.40	.60	.80	1.00	82.5	6.03	.56	.81	1.00	67.7	6.65	.53	.82	1.00	52.9	7.28	.49	.83	1.00
	7200	103.0	5.44	.63	.87	1.00	86.4	6.04	.61	.90	1.00	69.7	6.64	.59	.94	1.00	53.0	7.23	.57	.97	1.00
67°F	4800	103.7	5.47	.41	.57	.72	90.4	6.13	.34	.53	.72	77.0	6.78	.28	.49	.71	63.6	7.44	.21	.46	.71
	6000	108.5	5.51	.43	.61	.79	94.0	6.14	.37	.59	.81	79.5	6.76	.31	.56	.82	65.0	7.39	.25	.54	.84
	7200	113.3	5.54	.44	.65	.86	97.6	6.14	.39	.64	.90	82.0	6.75	.33	.63	.93	66.3	7.35	.28	.63	.97
71°F	4800	115.9	5.58	.25	.39	.53	102.1	6.24	.17	.33	.50	88.2	6.90	.09	.28	.46	74.4	7.55	.01	.22	.43
	6000	119.7	5.61	.25	.41	.57	105.5	6.24	.17	.36	.55	91.2	6.87	.08	.30	.52	77.0	7.51	.00	.25	.50
	7200	123.5	5.64	.25	.43	.61	108.9	6.25	.17	.38	.60	94.2	6.85	.08	.33	.58	79.6	7.46	-.01	.28	.57

## 15 TON HIGH EFFICIENCY LCH180H4B WITH HUMIDITROL® OPERATING (2ND STAGE) - CONSTANT AIR VOLUME

Entering Wet Bulb Temperature	Total Air Volume	Outdoor Air Temperature Entering Outdoor Coil																			
		65°F					75°F					85°F					95°F				
		Total Cool Cap.	Comp. Motor Input	Sensible To Total Ratio (S/T)			Total Cool Cap.	Comp. Motor Input	Sensible To Total Ratio (S/T)			Total Cool Cap.	Comp. Motor Input	Sensible To Total Ratio (S/T)			Total Cool Cap.	Comp. Motor Input	Sensible To Total Ratio (S/T)		
				Dry Bulb					Dry Bulb					Dry Bulb					Dry Bulb		
cfm	kBtuh	kW	75°F	80°F	85°F	kBtuh	kW	75°F	80°F	85°F	kBtuh	kW	75°F	80°F	85°F	kBtuh	kW	75°F	80°F	85°F	
63°F	4800	154.5	8.08	.64	.80	.96	138.5	9.09	.63	.81	.99	122.4	10.11	.62	.82	1.00	106.3	11.13	.61	.83	1.00
	6000	163.3	8.13	.69	.87	1.00	144.9	9.13	.69	.89	1.00	126.4	10.12	.69	.90	1.00	108.0	11.12	.69	.92	1.00
	7200	172.0	8.18	.73	.94	1.00	151.3	9.16	.74	.96	1.00	130.5	10.14	.75	.98	1.00	109.7	11.12	.76	1.00	1.00
67°F	4800	171.4	8.23	.48	.62	.77	155.1	9.24	.45	.62	.79	138.8	10.25	.42	.61	.80	122.6	11.26	.39	.60	.81
	6000	180.3	8.27	.50	.65	.80	161.9	9.27	.48	.65	.83	143.5	10.27	.46	.66	.86	125.1	11.26	.44	.67	.90
	7200	189.2	8.31	.53	.67	.82	168.7	9.30	.51	.69	.87	148.2	10.28	.49	.71	.93	127.7	11.26	.48	.73	.98
71°F	4800	188.2	8.38	.31	.45	.59	171.7	9.39	.27	.42	.58	155.3	10.39	.23	.40	.57	138.9	11.40	.18	.37	.56
	6000	197.3	8.41	.31	.43	.54	179.0	9.41	.27	.42	.57	160.6	10.41	.23	.42	.61	142.3	11.40	.19	.41	.64
	7200	206.4	8.45	.32	.40	.49	186.2	9.43	.27	.42	.57	165.9	10.42	.23	.44	.65	145.7	11.41	.19	.46	.72



# HUMIDITROL® DEHUMIDIFICATION SYSTEM RATINGS

## 17.5 TON HIGH EFFICIENCY LCH210H4 WITH HUMIDITROL® OPERATING (1ST STAGE)

Entering Wet Bulb Temperature	Total Air Volume	Outdoor Air Temperature Entering Outdoor Coil																			
		65°F					75°F					85°F					95°F				
		Total Cool Cap.	Comp. Motor Input	Sensible To Total Ratio (S/T)			Total Cool Cap.	Comp. Motor Input	Sensible To Total Ratio (S/T)			Total Cool Cap.	Comp. Motor Input	Sensible To Total Ratio (S/T)			Total Cool Cap.	Comp. Motor Input	Sensible To Total Ratio (S/T)		
				Dry Bulb					Dry Bulb					Dry Bulb					Dry Bulb		
cfm	kBtuh	kW	75°F	80°F	85°F	kBtuh	kW	75°F	80°F	85°F	kBtuh	kW	75°F	80°F	85°F	kBtuh	kW	75°F	80°F	85°F	
63°F	5600	105.3	5.76	.58	.77	.96	91.1	6.45	.53	.75	.98	76.8	7.14	.48	.74	1.00	62.6	7.84	.43	.72	1.00
	7000	109.7	5.79	.63	.85	1.00	92.9	6.47	.60	.85	1.00	76.1	7.14	.57	.86	1.00	59.3	7.82	.54	.86	1.00
	8400	114.0	5.82	.68	.93	1.00	94.7	6.48	.67	.95	1.00	75.3	7.14	.65	.98	1.00	56.0	7.81	.64	1.00	1.00
67°F	5600	120.6	5.91	.42	.59	.77	105.7	6.59	.35	.55	.76	90.7	7.27	.29	.52	.74	75.8	7.95	.23	.48	.73
	7000	126.6	5.95	.45	.64	.83	108.8	6.62	.39	.62	.84	91.0	7.28	.33	.59	.86	73.1	7.95	.27	.57	.87
	8400	132.7	5.99	.47	.69	.90	111.9	6.64	.42	.68	.93	91.2	7.29	.37	.67	.97	70.5	7.94	.32	.66	1.00
71°F	5600	135.8	6.07	.26	.42	.58	120.2	6.74	.18	.36	.53	104.7	7.40	.10	.30	.49	89.1	8.06	.02	.23	.45
	7000	143.6	6.11	.26	.43	.60	124.7	6.77	.18	.38	.58	105.9	7.42	.10	.33	.56	87.0	8.07	.01	.28	.55
	8400	151.3	6.16	.27	.44	.62	129.2	6.80	.18	.40	.63	107.1	7.44	.09	.36	.64	84.9	8.08	.00	.32	.65

## 17.5 TON HIGH EFFICIENCY LCH210H4 WITH HUMIDITROL® OPERATING (2ND STAGE)

Entering Wet Bulb Temperature	Total Air Volume	Outdoor Air Temperature Entering Outdoor Coil																			
		65°F					75°F					85°F					95°F				
		Total Cool Cap.	Comp. Motor Input	Sensible To Total Ratio (S/T)			Total Cool Cap.	Comp. Motor Input	Sensible To Total Ratio (S/T)			Total Cool Cap.	Comp. Motor Input	Sensible To Total Ratio (S/T)			Total Cool Cap.	Comp. Motor Input	Sensible To Total Ratio (S/T)		
				Dry Bulb					Dry Bulb					Dry Bulb					Dry Bulb		
cfm	kBtuh	kW	75°F	80°F	85°F	kBtuh	kW	75°F	80°F	85°F	kBtuh	kW	75°F	80°F	85°F	kBtuh	kW	75°F	80°F	85°F	
63°F	5600	179.3	9.23	.65	.81	.98	162.1	10.35	.63	.82	1.00	144.9	11.47	.62	.83	1.00	127.6	12.60	.60	.83	1.00
	7000	189.8	9.32	.69	.87	1.00	170.6	10.43	.68	.88	1.00	151.4	11.54	.67	.89	1.00	132.2	12.64	.66	.90	1.00
	8400	200.2	9.42	.74	.94	1.00	179.0	10.51	.73	.95	1.00	157.9	11.60	.73	.96	1.00	136.7	12.69	.72	.98	1.00
67°F	5600	199.6	9.47	.48	.63	.79	181.4	10.58	.45	.62	.80	163.2	11.68	.43	.62	.81	144.9	12.78	.40	.61	.81
	7000	210.4	9.58	.51	.68	.85	190.2	10.67	.48	.67	.87	170.0	11.75	.46	.67	.88	149.8	12.84	.44	.66	.89
	8400	221.3	9.68	.54	.73	.92	199.1	10.76	.51	.72	.94	176.9	11.83	.49	.72	.95	154.6	12.91	.47	.72	.97
71°F	5600	219.9	9.72	.31	.45	.60	200.7	10.80	.28	.43	.59	181.5	11.88	.24	.41	.58	162.2	12.96	.20	.39	.57
	7000	231.1	9.83	.32	.48	.65	209.9	10.90	.28	.46	.64	188.6	11.97	.25	.44	.64	167.4	13.04	.21	.42	.64
	8400	242.4	9.93	.33	.52	.70	219.1	11.00	.29	.50	.70	195.8	12.06	.25	.48	.71	172.6	13.13	.21	.46	.71

## 20 TON HIGH EFFICIENCY LCH240H4 WITH HUMIDITROL® OPERATING (1ST STAGE)

Entering Wet Bulb Temperature	Total Air Volume	Outdoor Air Temperature Entering Outdoor Coil																			
		65°F					75°F					85°F					95°F				
		Total Cool Cap.	Comp. Motor Input	Sensible To Total Ratio (S/T)			Total Cool Cap.	Comp. Motor Input	Sensible To Total Ratio (S/T)			Total Cool Cap.	Comp. Motor Input	Sensible To Total Ratio (S/T)			Total Cool Cap.	Comp. Motor Input	Sensible To Total Ratio (S/T)		
				Dry Bulb					Dry Bulb					Dry Bulb					Dry Bulb		
cfm	kBtuh	kW	75°F	80°F	85°F	kBtuh	kW	75°F	80°F	85°F	kBtuh	kW	75°F	80°F	85°F	kBtuh	kW	75°F	80°F	85°F	
63°F	6400	91.1	5.34	.52	.70	.88	75.6	5.99	.43	.68	.93	60.0	6.63	.34	.66	.97	44.4	7.28	.25	.64	1.00
	8000	98.6	5.37	.54	.76	.97	80.6	5.99	.47	.76	1.00	62.7	6.61	.39	.77	1.00	44.7	7.23	.31	.78	1.00
	9600	106.1	5.40	.57	.82	1.00	85.7	5.99	.50	.85	1.00	65.3	6.59	.43	.88	1.00	45.0	7.19	.36	.92	1.00
67°F	6400	106.4	5.48	.37	.52	.68	89.5	6.12	.27	.48	.69	72.6	6.76	.17	.43	.69	55.7	7.40	.07	.38	.69
	8000	112.6	5.50	.38	.57	.75	94.4	6.12	.28	.53	.78	76.2	6.74	.18	.49	.80	58.0	7.36	.09	.46	.83
	9600	118.9	5.52	.39	.61	.82	99.3	6.12	.30	.58	.87	79.7	6.72	.20	.56	.92	60.2	7.32	.11	.54	.96
71°F	6400	121.7	5.62	.22	.35	.49	103.5	6.25	.10	.28	.45	85.3	6.88	-.01	.20	.40	67.1	7.52	-.12	.12	.36
	8000	126.7	5.63	.22	.38	.54	108.2	6.25	.10	.30	.49	89.7	6.87	-.02	.22	.45	71.2	7.49	-.13	.14	.41
	9600	131.6	5.64	.21	.40	.58	112.9	6.25	.09	.32	.54	94.1	6.85	-.02	.24	.49	75.4	7.46	-.14	.15	.45

## 20 TON HIGH EFFICIENCY LCH240H4 WITH HUMIDITROL® OPERATING (2ND STAGE)

Entering Wet Bulb Temperature	Total Air Volume	Outdoor Air Temperature Entering Outdoor Coil																			
		65°F					75°F					85°F					95°F				
		Total Cool Cap.	Comp. Motor Input	Sensible To Total Ratio (S/T)			Total Cool Cap.	Comp. Motor Input	Sensible To Total Ratio (S/T)			Total Cool Cap.	Comp. Motor Input	Sensible To Total Ratio (S/T)			Total Cool Cap.	Comp. Motor Input	Sensible To Total Ratio (S/T)		
				Dry Bulb					Dry Bulb					Dry Bulb					Dry Bulb		
cfm	kBtuh	kW	75°F	80°F	85°F	kBtuh	kW	75°F	80°F	85°F	kBtuh	kW	75°F	80°F	85°F	kBtuh	kW	75°F	80°F	85°F	
63°F	6400	215.7	10.70	.64	.79	.93	193.6	12.10	.63	.81	.99	171.4	13.50	.62	.84	1.00	149.3	14.90	.61	.86	1.00
	8000	226.5	10.73	.69	.86	1.00	201.6	12.10	.69	.88	1.00	176.6	13.48	.70	.91	1.00	151.7	14.86	.70	.93	1.00
	9600	237.4	10.76	.73	.94	1.00	209.6	12.11	.75	.96	1.00	181.8	13.46	.77	.98	1.00	154.0	14.81	.80	1.00	1.00
67°F	6400	240.5	10.89	.48	.62	.76	217.4	12.29	.46	.62	.79	194.3	13.69	.44	.63	.82	171.2	15.10	.42	.63	.85
	8000	249.1	10.91	.51	.67	.84	224.6	12.30	.49	.68	.86	200.1	13.69	.48	.68	.88	175.7	15.08	.46	.68	.91
	9600	257.6	10.94	.53	.73	.92	231.8	12.31	.53	.73	.93	206.0	13.68	.52	.73	.95	180.1	15.05	.51	.74	.96
71°F	6400	265.4	11.07	.32	.45	.58	241.3	12.48	.29	.44	.59	217.2	13.88	.25	.42	.59	193.1	15.29	.22	.40	.59
	8000	271.6	11.10	.33	.49	.64	247.6	12.50	.29	.47	.65	223.6	13.89	.26	.45	.65	199.6	15.29	.22	.44	.66
	9600	277.8	11.12	.34	.52	.70	254.0	12.51	.30	.50	.70	230.1	13.90	.26	.49	.71	206.2	15.29	.22	.47	.72



# HUMIDITROL® DEHUMIDIFICATION SYSTEM RATINGS

## 25 TON STANDARD EFFICIENCY LCH300S4 WITH HUMIDITROL® OPERATING (1ST STAGE)

Entering Wet Bulb Temperature	Total Air Volume	Outdoor Air Temperature Entering Outdoor Coil																			
		65°F					75°F					85°F					95°F				
		Total Cool Cap.	Comp. Motor Input	Sensible To Total Ratio (S/T)			Total Cool Cap.	Comp. Motor Input	Sensible To Total Ratio (S/T)			Total Cool Cap.	Comp. Motor Input	Sensible To Total Ratio (S/T)			Total Cool Cap.	Comp. Motor Input	Sensible To Total Ratio (S/T)		
				Dry Bulb					Dry Bulb					Dry Bulb					Dry Bulb		
		cfm	kBtuh	kW	75°F	80°F	85°F	kBtuh	kW	75°F	80°F	85°F	kBtuh	kW	75°F	80°F	85°F	kBtuh	kW	75°F	80°F
63°F	8000	100.4	7.25	.55	.74	.93	83.6	7.96	.47	.71	.96	66.7	8.67	.38	.69	.99	49.8	9.38	.29	.66	1.00
	9500	106.3	7.33	.58	.77	.97	89.3	8.02	.50	.76	.99	72.3	8.71	.42	.74	1.00	55.2	9.40	.34	.72	1.00
	11,000	112.2	7.40	.61	.81	.99	95.0	8.08	.53	.80	1.00	77.8	8.75	.46	.80	1.00	60.6	9.43	.38	.79	1.00
67°F	8000	116.1	7.40	.37	.54	.71	98.8	8.14	.27	.48	.70	81.5	8.87	.17	.43	.69	64.2	9.61	.07	.37	.68
	9500	122.7	7.460	0.38	0.56	0.74	104.2	8.190	0.28	0.51	0.74	85.8	8.910	0.18	0.46	0.74	67.3	9.635	0.08	0.41	0.75
	11,000	129.2	7.52	.40	.58	.77	109.6	8.24	.30	.54	.78	90.1	8.95	.20	.50	.80	70.5	9.66	.09	.46	.82
71°F	8000	131.7	7.55	.19	.34	.49	114.0	8.31	.07	.25	.44	96.3	9.07	-.04	.17	.38	78.6	9.83	-.16	.09	.33
	9500	139.0	7.60	.19	.35	.51	119.1	8.36	.07	.27	.46	99.3	9.11	-.06	.19	.43	79.5	9.86	-.18	.11	.38
	11,000	146.2	7.65	.19	.36	.52	124.2	8.40	.07	.28	.49	102.3	9.14	-.07	.20	.47	80.4	9.89	-.20	.12	.44

## 25 TON STANDARD EFFICIENCY LCH300S4 WITH HUMIDITROL® OPERATING (2ND STAGE)

Entering Wet Bulb Temperature	Total Air Volume	Outdoor Air Temperature Entering Outdoor Coil																			
		65°F					75°F					85°F					95°F				
		Total Cool Cap.	Comp. Motor Input	Sensible To Total Ratio (S/T)			Total Cool Cap.	Comp. Motor Input	Sensible To Total Ratio (S/T)			Total Cool Cap.	Comp. Motor Input	Sensible To Total Ratio (S/T)			Total Cool Cap.	Comp. Motor Input	Sensible To Total Ratio (S/T)		
				Dry Bulb					Dry Bulb					Dry Bulb					Dry Bulb		
		cfm	kBtuh	kW	75°F	80°F	85°F	kBtuh	kW	75°F	80°F	85°F	kBtuh	kW	75°F	80°F	85°F	kBtuh	kW	75°F	80°F
63°F	8000	260.3	14.9	.66	.80	.95	234.7	16.7	.65	.81	.97	209.1	18.5	.65	.82	.98	183.5	20.3	.65	.82	1.00
	9500	276.4	15.0	.69	.83	.96	248.2	16.8	.70	.84	.97	220.1	18.6	.70	.85	.99	191.9	20.4	.71	.85	1.00
	11,000	279.6	15.1	.73	.87	1.00	253.1	16.9	.75	.87	1.00	226.7	18.7	.76	.88	1.00	200.3	20.5	.78	.89	1.00
67°F	8000	283.9	15.2	.50	.64	.78	257.7	17.0	.48	.63	.79	231.5	18.8	.46	.63	.80	205.3	20.7	.44	.62	.81
	9500	294.1	15.3	.52	.67	.81	266.7	17.1	.51	.66	.82	239.3	18.9	.49	.66	.82	211.9	20.8	.48	.66	.83
	11,000	302.0	15.4	.54	.69	.84	274.2	17.2	.53	.69	.85	246.3	19.1	.53	.69	.86	218.4	20.9	.52	.69	.87
71°F	8000	307.5	15.5	.34	.47	.61	280.7	17.3	.31	.46	.61	253.9	19.2	.27	.44	.61	227.2	21.1	.24	.43	.61
	9500	311.7	15.5	.35	.51	.66	285.1	17.4	.32	.49	.66	258.5	19.3	.28	.47	.66	231.9	21.2	.25	.46	.66
	11,000	324.5	15.6	.35	.51	.67	295.2	17.5	.32	.51	.69	265.9	19.4	.29	.50	.71	236.6	21.3	.26	.50	.73

# BLOWER DATA

## BLOWER TABLE INCLUDES RESISTANCE FOR BASE UNIT ONLY WITH DRY INDOOR COIL & AIR FILTERS IN PLACE

### FOR ALL UNITS ADD:

- 1 - Wet indoor coil air resistance of selected unit.
- 2 - Any factory installed options air resistance (electric heat, economizer, etc.)
- 3 - Any field installed accessories air resistance (electric heat, duct resistance, diffuser, etc.)

Then determine from blower table blower motor output and drive required.

See page 45 for wet coil and option/accessory air resistance data.

See page 45 for factory installed drive kit specifications.

### MINIMUM AIR VOLUME REQUIRED FOR USE WITH OPTIONAL ELECTRIC HEAT

LCH156H units require 5200 cfm minimum air with electric heat.

All other units require 6000 cfm minimum air with electric heat.

Air Volume cfm	TOTAL STATIC PRESSURE - Inches Water Gauge (Pa)																									
	0.20		0.40		0.60		0.80		1.00		1.20		1.40		1.60		1.80		2.00		2.20		2.40		2.60	
	RPM	BHP	RPM	BHP	RPM	BHP	RPM	BHP	RPM	BHP	RPM	BHP	RPM	BHP	RPM	BHP	RPM	BHP	RPM	BHP	RPM	BHP	RPM	BHP	RPM	BHP
2750	385	0.30	505	0.50	600	0.70	680	0.90	755	1.10	820	1.30	885	1.50	950	1.70	1015	1.90	1080	2.10	1145	2.30	1210	2.50	1275	2.70
3000	395	0.35	515	0.55	610	0.75	695	1.00	760	1.20	825	1.45	890	1.65	955	1.85	1020	2.05	1085	2.25	1150	2.45	1215	2.65	1280	2.85
3250	405	0.40	520	0.60	615	0.85	695	1.10	765	1.30	830	1.60	895	1.80	955	2.00	1020	2.20	1085	2.40	1150	2.60	1215	2.80	1280	3.00
3500	415	0.45	530	0.70	620	0.95	700	1.20	775	1.45	840	1.70	900	1.90	965	2.10	1030	2.30	1095	2.50	1160	2.70	1225	2.90	1290	3.10
3750	425	0.50	540	0.75	630	1.05	710	1.30	780	1.60	845	1.85	905	2.05	970	2.25	1035	2.45	1100	2.65	1165	2.85	1230	3.05	1295	3.25
4000	435	0.55	545	0.85	635	1.10	715	1.40	785	1.70	850	1.95	910	2.15	975	2.35	1040	2.55	1105	2.75	1170	2.95	1235	3.15	1300	3.35
4250	445	0.60	555	0.90	645	1.25	725	1.55	795	1.85	855	2.10	915	2.30	980	2.50	1045	2.70	1110	2.90	1175	3.10	1240	3.30	1305	3.50
4500	455	0.70	565	1.00	655	1.35	730	1.65	800	2.00	865	2.25	925	2.45	990	2.65	1055	2.85	1120	3.05	1185	3.25	1250	3.45	1315	3.65
4750	470	0.75	575	1.10	660	1.45	740	1.80	810	2.15	870	2.40	930	2.60	995	2.80	1060	3.00	1125	3.20	1190	3.40	1255	3.60	1320	3.80
5000	480	0.85	585	1.25	670	1.60	750	1.95	815	2.30	880	2.55	940	2.75	1005	2.95	1070	3.15	1135	3.35	1200	3.55	1265	3.75	1330	3.95
5250	495	0.95	595	1.35	680	1.70	755	2.10	825	2.50	890	2.75	950	2.95	1015	3.15	1080	3.35	1145	3.55	1210	3.75	1275	3.95	1340	4.15
5500	505	1.05	605	1.45	690	1.85	765	2.25	835	2.65	895	2.90	955	3.10	1020	3.30	1085	3.50	1150	3.70	1215	3.90	1280	4.10	1345	4.30
5750	520	1.15	615	1.60	700	2.00	775	2.45	840	2.85	905	3.10	965	3.30	1030	3.50	1095	3.70	1160	3.90	1225	4.10	1290	4.30	1355	4.50
6000	530	1.30	630	1.75	710	2.15	785	2.60	850	3.05	910	3.30	970	3.50	1035	3.70	1100	3.90	1165	4.10	1230	4.30	1295	4.50	1360	4.70
6250	545	1.40	640	1.90	720	2.35	795	2.80	860	3.25	920	3.50	980	3.70	1045	3.90	1110	4.10	1175	4.30	1240	4.50	1305	4.70	1370	4.90
6500	560	1.55	650	2.05	730	2.50	805	3.00	870	3.45	930	3.70	990	3.90	1055	4.10	1120	4.30	1185	4.50	1250	4.70	1315	4.90	1380	5.10
6750	570	1.70	665	2.20	745	2.70	815	3.20	880	3.70	940	4.00	1000	4.20	1065	4.40	1130	4.60	1195	4.80	1260	5.00	1325	5.20	1390	5.40
7000	585	1.85	675	2.35	755	2.90	825	3.40	890	3.95	950	4.20	1010	4.40	1075	4.60	1140	4.80	1205	5.00	1270	5.20	1335	5.40	1400	5.60
7250	600	2.00	690	2.60	765	3.10	835	3.65	900	4.15	955	4.45	1015	4.65	1080	4.85	1145	5.05	1210	5.25	1275	5.45	1340	5.65	1405	5.85
7500	615	2.20	700	2.75	775	3.30	845	3.85	910	4.45	965	4.75	1025	4.95	1090	5.15	1155	5.35	1220	5.55	1285	5.75	1350	5.95	1415	6.15
7750	630	2.40	715	3.00	790	3.55	855	4.10	920	4.70	975	5.05	1035	5.25	1100	5.45	1165	5.65	1230	5.85	1295	6.05	1360	6.25	1425	6.45
8000	645	2.55	725	3.20	800	3.80	865	4.35	930	4.95	985	5.25	1045	5.45	1110	5.65	1175	5.85	1240	6.05	1305	6.25	1370	6.45	1435	6.65
8250	655	2.80	740	3.40	810	4.00	880	4.65	940	5.25	995	5.55	1055	5.75	1120	5.95	1185	6.15	1250	6.35	1315	6.55	1380	6.75	1445	6.95
8500	670	3.00	750	3.65	825	4.30	890	4.90	950	5.55	1005	5.85	1065	6.05	1130	6.25	1195	6.45	1260	6.65	1325	6.85	1390	7.05	1455	7.25
8750	685	3.25	765	3.90	835	4.55	900	5.20	960	5.85	1015	6.15	1075	6.35	1140	6.55	1205	6.75	1270	6.95	1335	7.15	1400	7.35	1465	7.55
9000	700	3.50	780	4.20	850	4.85	910	5.50	970	6.15	1025	6.45	1085	6.65	1150	6.85	1215	7.05	1280	7.25	1345	7.45	1410	7.65	1475	7.85
9250	715	3.75	790	4.45	860	5.15	925	5.85	985	6.55	1040	6.75	1100	6.95	1165	7.15	1230	7.35	1295	7.55	1360	7.75	1425	7.95	1490	8.15
9500	730	4.00	805	4.75	875	5.45	935	6.15	995	6.90	1050	7.15	1110	7.35	1175	7.55	1240	7.75	1305	7.95	1370	8.15	1435	8.35	1500	8.55
9750	745	4.30	820	5.05	885	5.75	950	6.55	1005	7.20	1060	7.45	1120	7.65	1185	7.85	1250	8.05	1315	8.25	1380	8.45	1445	8.65	1510	8.85
10,000	760	4.60	835	5.40	900	6.15	960	6.85	1015	7.60	1070	7.85	1130	8.05	1195	8.25	1260	8.45	1325	8.65	1390	8.85	1455	9.05	1520	9.25
10,250	775	4.90	845	5.65	910	6.45	970	7.20	1030	8.00	1080	8.25	1140	8.45	1205	8.65	1270	8.85	1335	9.05	1400	9.25	1465	9.45	1530	9.65
10,500	790	5.20	860	6.00	925	6.85	985	7.65	1040	8.40	1095	8.65	1155	8.85	1220	9.05	1285	9.25	1350	9.45	1415	9.65	1480	9.85	1540	10.05
10,750	805	5.55	875	6.40	940	7.25	1000	8.05	1055	8.85	1105	9.05	1170	9.25	1235	9.45	1300	9.65	1365	9.85	1430	10.05	1495	10.25	1555	10.45
11,000	820	5.90	890	6.80	950	7.60	1010	8.45	1065	9.30	1115	9.55	1180	9.75	1245	9.95	1310	10.15	1375	10.35	1440	10.55	1505	10.75	1565	10.95

## BLOWER DATA

### FACTORY INSTALLED BELT DRIVE KIT SPECIFICATIONS

Motor Efficiency	Nominal hp	Maximum hp	Drive Kit Number	RPM Range
Standard or High	2	2.30	1	535 - 725
Standard or High	2	2.30	2	710 - 965
Standard	3	3.45	1	535 - 725
Standard	3	3.45	2	710 - 965
High	3	3.45	3	685 - 856
High	3	3.45	4	850 - 1045
Standard	5	5.75	3	685 - 856
Standard	5	5.75	4	850 - 1045
Standard	5	5.75	5	945 - 1185
Standard	7.5	8.63	6	850 - 1045
Standard	7.5	8.63	7	945 - 1185
Standard	7.5	8.63	8	1045 - 1285
Standard	10	11.50	7	945 - 1185
Standard	10	11.50	10	1045 - 1285
Standard	10	11.50	11	1135 - 1365

NOTE - Using total air volume and system static pressure requirements determine from blower performance tables rpm and motor output required. Maximum usable output of motors furnished are shown. In Canada, nominal motor output is also maximum usable motor output. If motors of comparable output are used, be sure to keep within the service factor limitations outlined on the motor nameplate.

NOTE - Units equipped with MSAV® (Multi-Stage Air Volume) option are limited to a motor service factor of 1.0.

### FACTORY INSTALLED OPTIONS/FIELD INSTALLED ACCESSORY AIR RESISTANCE

Air Volume cfm	Wet Indoor Coil		Humiditrol® Condenser Reheat Coil	Electric Heat	Economizer	Filters		Horizontal Roof Curb	
	156H, 180H	210H, 240H 300S				156H thru 240H	300S		
	in. w.g.	in. w.g.	in. w.g.	in. w.g.	in. w.g.			in. w.g.	MERV 8
2750	.01	.02	.01	---	---	.01	.03	.03	-
3000	.01	.02	.01	---	---	.01	.03	.04	-
3250	.01	.03	.01	---	---	.01	.04	.04	.01
3500	.01	.03	.02	---	---	.01	.04	.05	.01
3750	.01	.03	.02	---	---	.01	.04	.05	.01
4000	.02	.04	.02	---	---	.01	.04	.06	.02
4250	.02	.04	.02	---	---	.01	.05	.07	.02
4500	.02	.05	.02	---	---	.01	.05	.07	.02
4750	.02	.05	.02	---	---	.02	.05	.08	.03
5000	.02	.05	.02	---	---	.02	.06	.08	.03
5250	.02	.06	.03	---	---	.02	.06	.09	.04
5500	.02	.07	.03	---	---	.02	.06	.10	.04
5750	.03	.07	.03	---	---	.02	.07	.11	.05
6000	.03	.08	.03	.01	---	.03	.07	.11	.06
6250	.03	.08	.03	.01	.01	.03	.07	.12	.07
6500	.03	.09	.04	.01	.02	.03	.08	.13	.08
6750	.04	.10	.04	.01	.03	.03	.08	.14	.08
7000	.04	.10	.04	.01	.04	.04	.08	.15	.09
7250	.04	.11	.04	.01	.05	.04	.09	.16	.10
7500	.05	.12	.05	.01	.06	.04	.09	.17	.11
8000	.05	.13	.05	.02	.09	.05	.10	.19	.13
8500	.06	.15	.05	.02	.11	.05	.10	.21	.15
9000	.07	.16	.06	.04	.14	.06	.11	.24	.17
9500	.08	.18	.07	.05	.16	.07	.12	.26	.19
10,000	.08	.20	.07	.06	.19	.07	.12	.29	.21
10,500	.09	.22	.08	.09	.22	.08	.13	.31	.24
11,000	.11	.24	.08	.11	.25	.09	.14	.34	.27

## BLOWER DATA

### POWER EXHAUST FAN PERFORMANCE

Return Air System Static Pressure	Air Volume Exhausted
in. w.g.	cfm
0.00	8630
0.05	8210
0.10	7725
0.15	7110
0.20	6470
0.25	5790
0.30	5060
0.35	4300
0.40	3510
0.45	2690
0.50	1840

### CEILING DIFFUSER AIR RESISTANCE - in. w.g.

Air Volume cfm	Step-Down Diffuser						Flush Diffuser	
	RTD11-185S			RTD11-275S			FD11-185S	FD11-275S
	2 Ends Open	1 Side/2 Ends Open	All Ends & Sides Open	2 Ends Open	1 Side/2 Ends Open	All Ends & Sides Open		
5000	.51	.44	.39	---	---	---	.27	---
5200	.56	.48	.42	---	---	---	.30	---
5400	.61	.52	.45	---	---	---	.33	---
5600	.66	.56	.48	---	---	---	.36	---
5800	.71	.59	.51	---	---	---	.39	---
6000	.76	.63	.55	.36	.31	.27	.42	.29
6200	.80	.68	.59	---	---	---	.46	---
6400	.86	.72	.63	---	---	---	.50	---
6500	---	---	---	.42	.36	.31	---	.34
6600	.92	.77	.67	---	---	---	.54	---
6800	.99	.83	.72	---	---	---	.58	---
7000	1.03	.87	.76	.49	.41	.36	.62	.40
7200	1.09	.92	.80	---	---	---	.66	---
7400	1.15	.97	.84	---	---	---	.70	---
7500	---	---	---	.51	.46	.41	---	.45
7600	1.20	1.02	.88	---	---	---	.74	---
8000	---	---	---	.59	.49	.43	---	.50
8500	---	---	---	.69	.58	.50	---	.57
9000	---	---	---	.79	.67	.58	---	.66
9500	---	---	---	.89	.75	.65	---	.74
10,000	---	---	---	1.00	.84	.73	---	.81
10,500	---	---	---	1.10	.92	.80	---	.89
11,000	---	---	---	1.21	1.01	.88	---	.96

### CEILING DIFFUSER AIR THROW DATA - ft.

Model No.	Air Volume cfm	<sup>1</sup> Effective Throw Range - ft.		Model No.	Air Volume cfm	<sup>1</sup> Effective Throw Range - ft.	
		RTD11-185S Step-Down	FD11-185S Flush			RTD11-275S Step-Down	FD11-275S Flush
156 180	5600	39 - 49	28 - 37	210 240 300	7200	33 - 38	26 - 35
	5800	42 - 51	29 - 38		7400	35 - 40	28 - 37
	6000	44 - 54	40 - 50		7600	36 - 41	29 - 38
	6200	45 - 55	42 - 51		7800	38 - 43	40 - 50
	6400	46 - 55	43 - 52		8000	39 - 44	42 - 51
	6600	47 - 56	45 - 56		8200	41 - 46	43 - 52
					8400	43 - 49	44 - 54
					8600	44 - 50	46 - 57
					8800	47 - 55	48 - 59

<sup>1</sup> Throw is the horizontal or vertical distance an airstream travels on leaving the outlet or diffuser before the maximum velocity is reduced to 50 ft. per minute. Four sides open.

**ELECTRICAL/ELECTRIC HEAT DATA**

**13 TON**

**13 TON HIGH EFFICIENCY**

**LCH156H4**

<sup>1</sup> Voltage - 60hz		208/230V - 3 Ph			460V - 3 Ph			575V - 3 Ph		
Compressor 1	Rated Load Amps	14.5			6.3			6.0		
	Locked Rotor Amps	98			55			41		
Compressor 2	Rated Load Amps	14.5			6.3			6		
	Locked Rotor Amps	98			55			41		
Compressor 3	Rated Load Amps	14.5			6.3			6		
	Locked Rotor Amps	98			55			41		
Outdoor Fan Motors (3)	Full Load Amps (total)	2.4 (7.2)			1.3 (3.9)			1 (3)		
Power Exhaust (2) 0.33 HP	Full Load Amps (total)	2.4 (4.8)			1.3 (2.6)			1 (2)		
Service Outlet 115V GFI (amps)		15			15			20		
Indoor Blower Motor	Horsepower	2	3	5	2	3	5	2	3	5
	Full Load Amps	7.5	10.6	16.7	3.4	4.8	7.6	2.7	3.9	6.1
<sup>2</sup> Maximum Overcurrent Protection	Unit Only	70	70	80	30	35	35	30	30	30
	With (2) 0.33 HP Power Exhaust	80	80	90	35	35	40	30	30	35
<sup>3</sup> Minimum Circuit Ampacity	Unit Only	62	65	72	28	30	33	26	27	29
	With (2) 0.33 HP Power Exhaust	67	70	77	31	32	35	28	29	31

**ELECTRIC HEAT DATA**

		Electric Heat Voltage	208V	240V	208V	240V	208V	240V	480V	480V	480V	600V	600V	600V
<sup>2</sup> Maximum Overcurrent Protection	Unit+ Electric Heat	15 kW	70	70	70	70	80	80	30	35	35	30	30	30
		30 kW	<sup>4</sup> 90	100	<sup>4</sup> 100	110	<sup>4</sup> 100	125	50	60	60	40	45	45
		45 kW	150	150	150	150	<sup>4</sup> 150	175	80	80	80	60	60	70
		60 kW	<sup>4</sup> 150	175	<sup>4</sup> 150	175	<sup>4</sup> 150	175	80	80	90	70	70	70
<sup>3</sup> Minimum Circuit Ampacity	Unit+ Electric Heat	15 kW	62	62	65	65	72	72	28	30	33	26	27	29
		30 kW	88	100	92	104	100	112	50	52	55	40	41	44
		45 kW	127	145	131	149	139	157	72	74	78	58	60	62
		60 kW	135	154	139	158	146	166	77	79	82	62	63	66
<sup>2</sup> Maximum Overcurrent Protection	Unit+ Electric Heat and (2) 0.33 HP Power Exhaust	15 kW	80	80	80	80	90	90	35	35	40	30	30	35
		30 kW	<sup>4</sup> 100	110	<sup>4</sup> 100	110	<sup>4</sup> 110	125	60	60	60	45	45	50
		45 kW	<sup>4</sup> 150	175	<sup>4</sup> 150	175	<sup>4</sup> 150	175	80	80	90	70	70	70
		60 kW	<sup>4</sup> 150	175	<sup>4</sup> 150	175	175	175	80	90	90	70	70	70
<sup>3</sup> Minimum Circuit Ampacity	Unit+ Electric Heat and (2) 0.33 HP Power Exhaust	15 kW	67	67	70	70	77	77	31	32	36	28	29	31
		30 kW	94	106	98	110	106	118	53	55	58	42	44	47
		45 kW	133	151	137	155	145	163	76	77	81	61	62	65
		60 kW	141	160	145	164	152	172	80	82	85	64	66	68

NOTE - All units have a minimum Short Circuit Current Rating (SCCR) of 5000 amps.

<sup>1</sup> Extremes of operating range are plus and minus 10% of line voltage.

<sup>2</sup> HACR type breaker or fuse.

<sup>3</sup> Refer to National or Canadian Electrical Code manual to determine wire, fuse and disconnect size requirements.

<sup>4</sup> Factory installed circuit breaker not available.

**ELECTRICAL/ELECTRIC HEAT DATA**

**15 TON**

**15 TON HIGH EFFICIENCY**

**LCH180H4**

<sup>1</sup> Voltage - 60hz		208/230V - 3 Ph			460V - 3 Ph			575V - 3 Ph		
Compressor 1	Rated Load Amps	13.2			6.3			4.9		
	Locked Rotor Amps	93			60			41		
Compressor 2	Rated Load Amps	13.2			6.3			4.9		
	Locked Rotor Amps	93			60			41		
Compressor 3	Rated Load Amps	13.2			6.3			4.9		
	Locked Rotor Amps	93			60			41		
Outdoor Fan Motors (8)	Full Load Amps (total)	2.4 (9.6)			1.3 (5.2)			1 (4)		
Power Exhaust (2) 0.33 HP	Full Load Amps (total)	2.4 (4.8)			1.3 (2.6)			1 (2)		
Service Outlet 115V GFI (amps)		15			15			20		
Indoor Blower Motor	Horsepower	3	5	7.5	3	5	7.5	3	5	7.5
	Full Load Amps	10.6	16.7	24.2	4.8	7.6	11	3.9	6.1	9
<sup>2</sup> Maximum Overcurrent Protection	Unit Only	70	80	100	35	40	45	25	30	35
	With (2) 0.33 HP Power Exhaust	80	90	100	35	40	50	30	30	40
<sup>3</sup> Minimum Circuit Ampacity	Unit Only	64	71	80	31	34	38	24	27	30
	With (2) 0.33 HP Power Exhaust	68	75	85	34	37	41	26	29	32

**ELECTRIC HEAT DATA**

Electric Heat Voltage		208V	240V	208V	240V	208V	240V	480V	480V	480V	600V	600V	600V	
<sup>2</sup> Maximum Overcurrent Protection	Unit+ Electric Heat	<b>15 kW</b>	70	70	80	80	100	100	35	40	45	25	30	35
		<b>30 kW</b>	<sup>4</sup> 100	110	<sup>4</sup> 100	125	<sup>4</sup> 110	125	60	60	60	45	45	50
		<b>45 kW</b>	150	150	<sup>4</sup> 150	175	<sup>4</sup> 150	175	80	80	90	60	70	70
		<b>60 kW</b>	<sup>4</sup> 150	175	<sup>4</sup> 150	175	175	175	80	90	90	70	70	70
<sup>3</sup> Minimum Circuit Ampacity	Unit+ Electric Heat	<b>15 kW</b>	64	64	71	71	80	80	31	34	38	24	27	30
		<b>30 kW</b>	92	104	100	112	109	121	52	55	59	41	44	48
		<b>45 kW</b>	131	149	139	157	148	166	74	78	82	60	62	66
		<b>60 kW</b>	139	158	146	166	156	175	79	82	86	63	66	69
<sup>2</sup> Maximum Overcurrent Protection	Unit+ Electric Heat and (2) 0.33 HP Power Exhaust	<b>15 kW</b>	80	80	90	90	100	100	35	40	50	30	30	40
		<b>30 kW</b>	<sup>4</sup> 100	110	<sup>4</sup> 110	125	<sup>4</sup> 125	150	60	60	70	45	50	50
		<b>45 kW</b>	<sup>4</sup> 150	175	<sup>4</sup> 150	175	175	175	80	90	90	70	70	70
		<b>60 kW</b>	<sup>4</sup> 150	175	175	175	<sup>4</sup> 175	200	90	90	90	70	70	80
<sup>3</sup> Minimum Circuit Ampacity	Unit+ Electric Heat and (2) 0.33 HP Power Exhaust	<b>15 kW</b>	68	68	75	75	85	85	34	37	41	26	29	32
		<b>30 kW</b>	98	110	106	118	115	127	55	58	63	44	47	50
		<b>45 kW</b>	137	155	145	163	154	172	77	81	85	62	65	68
		<b>60 kW</b>	145	164	152	172	162	181	82	85	90	66	68	72

NOTE - All units have a minimum Short Circuit Current Rating (SCCR) of 5000 amps.

<sup>1</sup> Extremes of operating range are plus and minus 10% of line voltage.

<sup>2</sup> HACR type breaker or fuse.

<sup>3</sup> Refer to National or Canadian Electrical Code manual to determine wire, fuse and disconnect size requirements.

<sup>4</sup> Factory installed circuit breaker not available.



**ELECTRICAL/ELECTRIC HEAT DATA**

**17.5 TON**

**17.5 TON HIGH EFFICIENCY**

**LCH210H4B/M**

<sup>1</sup> Voltage - 60hz		208/230V - 3 Ph			460V - 3 Ph			575V - 3 Ph		
Compressor 1	Rated Load Amps	15.6			7.8			5.8		
	Locked Rotor Amps	110			52			38.9		
Compressor 2	Rated Load Amps	15.6			7.8			5.8		
	Locked Rotor Amps	110			52			38.9		
Compressor 3	Rated Load Amps	19.6			8.2			6.6		
	Locked Rotor Amps	136			66.1			55.3		
Outdoor Fan Motors (3)	Full Load Amps (total)	2.4 (14.4)			1.3 (7.8)			1 (6)		
Power Exhaust (2) 0.33 HP	Full Load Amps (total)	2.4 (4.8)			1.3 (2.6)			1 (2)		
Service Outlet 115V GFI (amps)		15			15			15		
Indoor Blower Motor	Horsepower	3	5	7.5	3	5	7.5	3	5	7.5
	Full Load Amps	10.6	16.7	24.2	4.8	7.6	11	3.9	6.1	9
<sup>2</sup> Maximum Overcurrent Protection	Unit Only	100	100	110	45	45	50	35	35	40
	With (2) 0.33 HP Power Exhaust	100	110	110	45	50	50	35	40	45
<sup>3</sup> Minimum Circuit Ampacity	Unit Only	81	87	96	39	42	46	30	32	36
	With (2) 0.33 HP Power Exhaust	86	92	101	42	44	48	32	34	38

**ELECTRIC HEAT DATA**

		Electric Heat Voltage	208V	240V	208V	240V	208V	240V	480V	480V	480V	600V	600V	600V
<sup>2</sup> Maximum Overcurrent Protection	Unit+ Electric Heat	15 kW	100	100	100	100	110	110	45	45	50	35	35	40
		30 kW	<sup>4</sup> 100	110	<sup>4</sup> 100	125	<sup>4</sup> 110	125	60	60	60	45	45	50
		45 kW	150	150	<sup>4</sup> 150	175	<sup>4</sup> 150	175	80	80	90	60	70	70
		60 kW	<sup>4</sup> 150	175	<sup>4</sup> 150	175	175	175	80	90	90	70	70	70
		90 kW	<sup>4</sup> 225	250	<sup>4</sup> 225	250	<sup>4</sup> 225	250	125	125	125	100	100	100
<sup>3</sup> Minimum Circuit Ampacity	Unit+ Electric Heat	15 kW	81	81	87	87	96	96	39	42	46	30	32	36
		30 kW	92	104	100	112	109	121	52	55	59	41	44	48
		45 kW	131	149	139	157	148	166	74	78	82	60	62	66
		60 kW	139	158	146	166	156	175	79	82	86	63	66	69
		90 kW	201	230	209	238	218	247	115	118	123	92	95	98
<sup>2</sup> Maximum Overcurrent Protection	Unit+ Electric Heat and (2) 0.33 HP Power Exhaust	15 kW	100	100	110	110	110	110	45	50	50	35	40	45
		30 kW	<sup>4</sup> 100	110	<sup>4</sup> 110	125	<sup>4</sup> 125	150	60	60	70	45	50	50
		45 kW	<sup>4</sup> 150	175	<sup>4</sup> 150	175	175	175	80	90	90	70	70	70
		60 kW	<sup>4</sup> 150	175	175	175	<sup>4</sup> 175	200	90	90	90	70	70	80
		90 kW	<sup>4</sup> 225	250	<sup>4</sup> 225	250	<sup>4</sup> 225	<sup>4</sup> 300	125	125	150	100	100	110
<sup>3</sup> Minimum Circuit Ampacity	Unit+ Electric Heat and (2) 0.33 HP Power Exhaust	15 kW	86	86	92	92	101	101	42	44	48	32	34	38
		30 kW	98	110	106	118	115	127	55	58	63	44	47	50
		45 kW	137	155	145	163	154	172	77	81	85	62	65	68
		60 kW	145	164	152	172	162	181	82	85	90	66	68	72
		90 kW	207	236	215	244	224	253	118	122	126	94	97	101

NOTE - All units have a minimum Short Circuit Current Rating (SCCR) of 5000 amps.

<sup>1</sup> Extremes of operating range are plus and minus 10% of line voltage.

<sup>2</sup> HACR type breaker or fuse.

<sup>3</sup> Refer to National or Canadian Electrical Code manual to determine wire, fuse and disconnect size requirements.

<sup>4</sup> Factory installed circuit breaker not available.

**ELECTRICAL/ELECTRIC HEAT DATA**

**20 TON**

**20 TON HIGH EFFICIENCY**

**LCH240H4**

<sup>1</sup> Voltage - 60hz		208/230V - 3 Ph			460V - 3 Ph			575V - 3 Ph		
Compressor 1	Rated Load Amps	13.2			6.3			4.9		
	Locked Rotor Amps	93			60			41		
Compressor 2	Rated Load Amps	13.2			6.3			4.9		
	Locked Rotor Amps	93			60			41		
Compressor 3	Rated Load Amps	13.2			6.3			4.9		
	Locked Rotor Amps	93			60			41		
Compressor 4	Rated Load Amps	13.2			6.3			4.9		
	Locked Rotor Amps	93			60			41		
Outdoor Fan Motors (6)	Full Load Amps (total)	2.4 (14.4)			1.3 (7.8)			1 (6)		
Power Exhaust (2) 0.33 HP	Full Load Amps (total)	2.4 (4.8)			1.3 (2.6)			1 (2)		
Service Outlet 115V GFI (amps)		15			15			20		
Indoor Blower Motor	Horsepower	5	7.5	10	5	7.5	10	5	7.5	10
	Full Load Amps	16.7	24.2	30.8	7.6	11	14	6.1	9	11
<sup>2</sup> Maximum Overcurrent Protection	Unit Only	100	110	125	50	50	60	35	45	50
	With (2) 0.33 HP Power Exhaust	100	125	125	50	60	60	40	45	50
<sup>3</sup> Minimum Circuit Ampacity	Unit Only	89	98	106	43	47	51	34	37	40
	With (2) 0.33 HP Power Exhaust	93	103	111	46	50	54	36	39	42

**ELECTRIC HEAT DATA**

		Electric Heat Voltage	208V	240V	208V	240V	208V	240V	480V	480V	480V	600V	600V	600V
<sup>2</sup> Maximum Overcurrent Protection	Unit+ Electric Heat	15 kW	100	100	110	110	125	125	50	50	60	35	45	50
		30 kW	<sup>4</sup> 100	125	<sup>4</sup> 110	125	<sup>4</sup> 125	150	60	60	70	45	50	50
		45 kW	<sup>4</sup> 150	175	<sup>4</sup> 150	175	175	175	80	90	90	70	70	70
		60 kW	<sup>4</sup> 150	175	175	175	<sup>4</sup> 175	200	90	90	90	70	70	80
		90 kW	<sup>4</sup> 225	250	<sup>4</sup> 225	250	<sup>4</sup> 250	<sup>4</sup> 300	125	125	150	100	100	110
<sup>3</sup> Minimum Circuit Ampacity	Unit+ Electric Heat	15 kW	89	89	98	98	106	106	43	47	51	34	37	40
		30 kW	100	112	109	121	117	129	55	59	63	44	48	50
		45 kW	139	157	148	166	156	174	78	82	86	62	66	68
		60 kW	146	166	156	175	164	183	82	86	90	66	69	72
		90 kW	209	238	218	247	227	256	118	123	126	95	98	101
<sup>2</sup> Maximum Overcurrent Protection	Unit+ Electric Heat and (2) 0.33 HP Power Exhaust	15 kW	100	100	125	125	125	125	50	60	60	40	45	50
		30 kW	<sup>4</sup> 110	125	<sup>4</sup> 125	150	<sup>4</sup> 125	150	60	70	70	50	50	60
		45 kW	<sup>4</sup> 150	175	175	175	<sup>4</sup> 175	200	90	90	90	70	70	80
		60 kW	175	175	<sup>4</sup> 175	200	<sup>4</sup> 175	200	90	90	100	70	80	80
		90 kW	<sup>4</sup> 225	250	<sup>4</sup> 225	<sup>4</sup> 300	<sup>4</sup> 250	<sup>4</sup> 300	125	150	150	100	110	110
<sup>3</sup> Minimum Circuit Ampacity	Unit+ Electric Heat and (2) 0.33 HP Power Exhaust	15 kW	93	93	103	103	111	111	46	50	54	36	39	42
		30 kW	106	118	115	127	123	135	58	63	66	47	50	53
		45 kW	145	163	154	172	162	180	81	85	89	65	68	71
		60 kW	152	172	162	181	170	189	85	90	93	68	72	74
		90 kW	215	244	224	253	233	262	122	126	130	97	101	103

NOTE - All units have a minimum Short Circuit Current Rating (SCCR) of 5000 amps.

<sup>1</sup> Extremes of operating range are plus and minus 10% of line voltage.

<sup>2</sup> HACR type breaker or fuse.

<sup>3</sup> Refer to National or Canadian Electrical Code manual to determine wire, fuse and disconnect size requirements.

<sup>4</sup> Factory installed circuit breaker not available.

**ELECTRICAL/ELECTRIC HEAT DATA**

**25 TON**

**25 TON STANDARD EFFICIENCY**

**LCH300S4B/M**

<sup>1</sup> Voltage - 60hz		208/230V - 3 Ph			460V - 3 Ph			575V - 3 Ph		
Compressor 1	Rated Load Amps	19.6			8.2			6.6		
	Locked Rotor Amps	136			66.1			55.3		
Compressor 2	Rated Load Amps	19.6			8.2			6.6		
	Locked Rotor Amps	136			66.1			55.3		
Compressor 3	Rated Load Amps	22.4			10.6			7.7		
	Locked Rotor Amps	149			75			54		
Compressor 4	Rated Load Amps	22.4			10.6			7.7		
	Locked Rotor Amps	149			75			54		
Outdoor Fan Motors (6)	Full Load Amps (total)	2.4 (14.4)			1.3 (7.8)			1 (6)		
Power Exhaust (2) 0.33 HP	Full Load Amps (total)	2.4 (4.8)			1.3 (2.6)			1 (2)		
Service Outlet 115V GFI (amps)		15			15			20		
Indoor Blower Motor	Horsepower	5	7.5	10	5	7.5	10	5	7.5	10
	Full Load Amps	16.7	24.2	30.8	7.6	11	14	6.1	9	11
<sup>2</sup> Maximum Overcurrent Protection	Unit Only	125	150	150	60	70	70	50	50	50
	With (2) 0.33 HP Power Exhaust	150	150	150	60	70	70	50	50	60
<sup>3</sup> Minimum Circuit Ampacity	Unit Only	121	129	137	56	60	63	45	46	49
	With (2) 0.33 HP Power Exhaust	126	134	142	59	62	66	45	48	51

**ELECTRIC HEAT DATA**

		Electric Heat Voltage	208V	240V	208V	240V	208V	240V	480V	480V	480V	600V	600V	600V
<sup>2</sup> Maximum Overcurrent Protection	Unit+ Electric Heat	15 kW	125	125	150	150	150	150	60	70	70	50	50	50
		30 kW	125	125	150	150	150	150	60	70	70	50	50	50
		45 kW	<sup>4</sup> 150	175	<sup>4</sup> 150	175	175	175	80	90	90	70	70	70
		60 kW	<sup>4</sup> 150	175	175	175	<sup>4</sup> 175	200	90	90	90	70	70	80
		90 kW	<sup>4</sup> 225	250	<sup>4</sup> 225	250	<sup>4</sup> 250	<sup>4</sup> 300	125	125	150	100	100	110
<sup>3</sup> Minimum Circuit Ampacity	Unit+ Electric Heat	15 kW	121	121	129	129	137	137	56	60	63	45	46	49
		30 kW	121	121	129	129	137	137	56	60	63	45	46	49
		45 kW	139	157	148	166	156	174	78	82	86	62	66	68
		60 kW	146	166	156	175	164	183	82	86	90	66	69	72
		90 kW	209	238	218	247	227	256	118	123	126	95	98	101
<sup>2</sup> Maximum Overcurrent Protection	Unit+ Electric Heat and (2) 0.33 HP Power Exhaust	15 kW	150	150	150	150	150	150	60	70	70	50	50	60
		30 kW	150	150	150	150	150	150	60	70	70	50	50	60
		45 kW	<sup>4</sup> 150	175	175	175	<sup>4</sup> 175	200	90	90	90	70	70	80
		60 kW	175	175	<sup>4</sup> 175	200	<sup>4</sup> 175	200	90	90	100	70	80	80
		90 kW	<sup>4</sup> 225	250	<sup>4</sup> 225	<sup>4</sup> 300	<sup>4</sup> 250	<sup>4</sup> 300	125	150	150	100	110	110
<sup>3</sup> Minimum Circuit Ampacity	Unit+ Electric Heat and (2) 0.33 HP Power Exhaust	15 kW	126	126	134	134	142	142	59	62	66	45	48	51
		30 kW	126	126	134	134	142	142	59	62	66	45	48	51
		45 kW	145	163	154	172	162	180	81	85	89	65	68	71
		60 kW	152	172	162	181	170	189	85	90	93	68	72	74
		90 kW	215	244	224	253	233	262	122	126	130	97	101	103

NOTE - All units have a minimum Short Circuit Current Rating (SCCR) of 5000 amps.

<sup>1</sup> Extremes of operating range are plus and minus 10% of line voltage.

<sup>2</sup> HACR type breaker or fuse.

<sup>3</sup> Refer to National or Canadian Electrical Code manual to determine wire, fuse and disconnect size requirements.

<sup>4</sup> Factory installed circuit breaker not available.

## ELECTRICAL ACCESSORIES - DISCONNECTS

### 13 TON | LCH156H4

Motor Horsepower	2		3		5		2	3	5	2	3	5
	208V	240V	208V	240V	208V	240V	480V	480V	480V	600V	600V	600V
Unit Only	54W85	54W85	54W85	54W85	54W85	54W85	54W85	54W85	54W85	54W85	54W85	54W85
+ Power Exhaust	54W85	54W85	54W85	54W85	54W86	54W86	54W85	54W85	54W85	54W85	54W85	54W85
+ Electric Heat 15 kW	54W85	54W85	54W85	54W85	54W85	54W85	54W85	54W85	54W85	54W85	54W85	54W85
+ Electric Heat 30 kW	54W86	54W86	54W86	54W86	54W86	54W86	54W85	54W85	54W85	54W85	54W85	54W85
+ Electric Heat 45 kW	54W86	54W86	54W86	54W86	54W86	54W86	54W85	54W85	54W85	54W85	54W85	54W85
+ Electric Heat 60 kW	54W87	54W87	54W87	54W87	54W87	54W87	54W86	54W86	54W86	54W85	54W85	54W85
+ Power Exhaust + Elec. Heat 15 kW	54W85	54W85	54W85	54W85	54W85	54W85	54W85	54W85	54W85	54W85	54W85	54W85
+ Power Exhaust + Elec. Heat 30 kW	54W86	54W86	54W86	54W86	54W86	54W86	54W85	54W85	54W85	54W85	54W85	54W85
+ Power Exhaust + Elec. Heat 45 kW	54W86	54W86	54W86	54W86	54W86	54W86	54W85	54W85	54W85	54W85	54W85	54W85
+ Power Exhaust + Elec. Heat 60 kW	54W87	54W87	54W87	54W87	54W87	54W87	54W86	54W86	54W86	54W85	54W85	54W85

### 15 TON | LCH180H4

Motor Horsepower	3		5		7.5		3	5	7.5	3	5	7.5
	208V	240V	208V	240V	208V	240V	480V	480V	480V	600V	600V	600V
Unit Only	54W85	54W85	54W85	54W85	54W86	54W86	54W85	54W85	54W85	54W85	54W85	54W85
+ Power Exhaust	54W85	54W85	54W86	54W86	54W86	54W86	54W85	54W85	54W85	54W85	54W85	54W85
+ Electric Heat 15 kW	54W85	54W85	54W85	54W85	54W85	54W85	54W85	54W85	54W85	54W85	54W85	54W85
+ Electric Heat 30 kW	54W86	54W86	54W86	54W86	54W86	54W86	54W85	54W85	54W85	54W85	54W85	54W85
+ Electric Heat 45 kW	54W86	54W86	54W86	54W86	54W86	54W87	54W85	54W85	54W85	54W85	54W85	54W85
+ Electric Heat 60 kW	54W87	54W87	54W87	54W87	54W87	54W87	54W86	54W86	54W86	54W85	54W85	54W85
+ Power Exhaust + Elec. Heat 15 kW	54W85	54W85	54W85	54W85	54W85	54W85	54W85	54W85	54W85	54W85	54W85	54W85
+ Power Exhaust + Elec. Heat 30 kW	54W86	54W86	54W86	54W86	54W86	54W86	54W85	54W85	54W85	54W85	54W85	54W85
+ Power Exhaust + Elec. Heat 45 kW	54W86	54W86	54W86	54W86	54W86	54W87	54W85	54W85	54W85	54W85	54W85	54W85
+ Power Exhaust + Elec. Heat 60 kW	54W87	54W87	54W87	54W87	54W87	54W87	54W86	54W86	54W86	54W85	54W85	54W85

### 17.5 TON | LCH210H4

Motor Horsepower	3		5		7.5		3	5	7.5	3	5	7.5
	208V	240V	208V	240V	208V	240V	480V	480V	480V	600V	600V	600V
Unit Only	54W86	54W86	54W86	54W86	54W86	54W86	54W85	54W85	54W85	54W85	54W85	54W85
+ Power Exhaust	54W86	54W86	54W86	54W86	54W86	54W86	54W85	54W85	54W85	54W85	54W85	54W85
+ Electric Heat 15 kW	54W85	54W85	54W85	54W85	54W85	54W85	54W85	54W85	54W85	54W85	54W85	54W85
+ Electric Heat 30 kW	54W86	54W86	54W86	54W86	54W86	54W86	54W85	54W85	54W85	54W85	54W85	54W85
+ Electric Heat 45 kW	54W86	54W86	54W86	54W86	54W86	54W87	54W85	54W85	54W85	54W85	54W85	54W85
+ Electric Heat 60 kW	54W87	54W87	54W87	54W87	54W87	54W87	54W86	54W86	54W86	54W85	54W85	54W85
+ Electric Heat 90 kW	<sup>1</sup> N/A	<sup>1</sup> N/A	<sup>1</sup> N/A	<sup>1</sup> N/A	<sup>1</sup> N/A	<sup>1</sup> N/A	54W86	54W86	54W86	54W86	54W86	54W86
+ Power Exhaust + Elec. Heat 15 kW	54W85	54W85	54W85	54W85	54W85	54W85	54W85	54W85	54W85	54W85	54W85	54W85
+ Power Exhaust + Elec. Heat 30 kW	54W86	54W86	54W86	54W86	54W86	54W86	54W85	54W85	54W85	54W85	54W85	54W85
+ Power Exhaust + Elec. Heat 45 kW	54W86	54W86	54W86	54W86	54W86	54W87	54W85	54W85	54W85	54W85	54W85	54W85
+ Power Exhaust + Elec. Heat 60 kW	54W87	54W87	54W87	54W87	54W87	54W87	54W86	54W86	54W86	54W85	54W85	54W85
+ Power Exhaust + Elec. Heat 90 kW	<sup>1</sup> N/A	<sup>1</sup> N/A	<sup>1</sup> N/A	<sup>1</sup> N/A	<sup>1</sup> N/A	<sup>1</sup> N/A	54W86	54W86	54W86	54W86	54W86	54W86

<sup>1</sup> Disconnect must be field furnished.

## ELECTRICAL ACCESSORIES - DISCONNECTS

### 20 TON | LCH240H4

Motor Horsepower	5		7.5		10		5	7.5	10	5	7.5	10
	208V	240V	208V	240V	208V	240V	480V	480V	480V	600V	600V	600V
Unit Only	54W86	54W86	54W86	54W86	54W86	54W86	54W85	54W85	54W85	54W85	54W85	54W85
+ Power Exhaust	54W86	54W86	54W86	54W86	54W86	54W86	54W85	54W85	54W85	54W85	54W85	54W85
+ Electric Heat 15 kW	54W85	54W85	54W85	54W85	54W85	54W85	54W85	54W85	54W85	54W85	54W85	54W85
+ Electric Heat 30 kW	54W86	54W86	54W86	54W86	54W86	54W86	54W85	54W85	54W85	54W85	54W85	54W85
+ Electric Heat 45 kW	54W86	54W86	54W86	54W87	54W86	54W87	54W85	54W85	54W85	54W85	54W85	54W85
+ Electric Heat 60 kW	54W87	54W87	54W87	54W87	54W87	54W87	54W86	54W86	54W86	54W85	54W85	54W85
+ Electric Heat 90 kW	<sup>1</sup> N/A	<sup>1</sup> N/A	<sup>1</sup> N/A	<sup>1</sup> N/A	<sup>1</sup> N/A	<sup>1</sup> N/A	54W86	54W86	54W86	54W86	54W86	54W86
+ Power Exhaust + Elec. Heat 15 kW	54W85	54W85	54W85	54W85	54W85	54W86	54W85	54W85	54W85	54W85	54W85	54W85
+ Power Exhaust + Elec. Heat 30 kW	54W86	54W86	54W86	54W86	54W86	54W86	54W85	54W85	54W85	54W85	54W85	54W85
+ Power Exhaust + Elec. Heat 45 kW	54W86	54W86	54W86	54W87	54W86	54W87	54W85	54W85	54W86	54W85	54W85	54W85
+ Power Exhaust + Elec. Heat 60 kW	54W87	54W87	54W87	54W87	54W87	54W87	54W86	54W86	54W86	54W85	54W85	54W86
+ Power Exhaust + Elec. Heat 90 kW	<sup>1</sup> N/A	<sup>1</sup> N/A	<sup>1</sup> N/A	<sup>1</sup> N/A	<sup>1</sup> N/A	<sup>1</sup> N/A	54W86	54W86	54W86	54W86	54W86	54W86

### 25 TON | LCH300S4

Motor Horsepower	5		7.5		10		5	7.5	10	5	7.5	10
	208V	240V	208V	240V	208V	240V	480V	480V	480V	600V	600V	600V
Unit Only	54W86	54W86	54W86	54W86	54W86	54W86	54W85	54W85	54W85	54W85	54W85	54W85
+ Power Exhaust	54W86	54W86	54W86	54W86	54W87	54W87	54W85	54W85	54W85	54W85	54W85	54W85
+ Electric Heat 15 kW	54W85	54W85	54W85	54W85	54W85	54W85	54W85	54W85	54W85	54W85	54W85	54W85
+ Electric Heat 30 kW	54W86	54W86	54W86	54W86	54W86	54W86	54W85	54W85	54W85	54W85	54W85	54W85
+ Electric Heat 45 kW	54W86	54W86	54W86	54W87	54W86	54W87	54W85	54W85	54W85	54W85	54W85	54W85
+ Electric Heat 60 kW	54W87	54W87	54W87	54W87	54W87	54W87	54W86	54W86	54W86	54W85	54W85	54W85
+ Electric Heat 90 kW	<sup>1</sup> N/A	<sup>1</sup> N/A	<sup>1</sup> N/A	<sup>1</sup> N/A	<sup>1</sup> N/A	<sup>1</sup> N/A	54W86	54W86	54W86	54W86	54W86	54W86
+ Power Exhaust + Elec. Heat 15 kW	54W85	54W85	54W85	54W85	54W85	54W86	54W85	54W85	54W85	54W85	54W85	54W85
+ Power Exhaust + Elec. Heat 30 kW	54W86	54W86	54W86	54W86	54W86	54W86	54W85	54W85	54W85	54W85	54W85	54W85
+ Power Exhaust + Elec. Heat 45 kW	54W86	54W86	54W86	54W87	54W86	54W87	54W85	54W85	54W86	54W85	54W85	54W85
+ Power Exhaust + Elec. Heat 60 kW	54W87	54W87	54W87	54W87	54W87	54W87	54W86	54W86	54W86	54W85	54W85	54W86
+ Power Exhaust + Elec. Heat 90 kW	<sup>1</sup> N/A	<sup>1</sup> N/A	<sup>1</sup> N/A	<sup>1</sup> N/A	<sup>1</sup> N/A	<sup>1</sup> N/A	54W86	54W86	54W86	54W86	54W86	54W86

<sup>1</sup> Disconnect must be field furnished.

## ELECTRIC HEAT CAPACITIES

Volts Input	15 kW			30 kW			45 kW			60 kW			90 kW		
	kW Input	Btuh Output	No. of Stages	kW Input	Btuh Output	No. of Stages	kW Input	Btuh Output	No. of Stages	kW Input	Btuh Output	No. of Stages	kW Input	Btuh Output	No. of Stages
208	11.3	38,600	1	22.5	76,800	1	33.8	115,300	2	45.0	153,600	2	67.6	230,700	2
220	12.6	43,000	1	25.2	86,000	1	37.8	129,000	2	50.4	172,000	2	75.6	258,000	2
230	13.8	47,100	1	27.5	93,900	1	41.3	141,000	2	55.1	188,000	2	82.7	282,200	2
240	15.0	51,200	1	30.0	102,400	1	45.0	153,600	2	60.0	204,800	2	90.0	307,100	2
440	12.6	43,000	1	25.2	86,000	1	37.8	129,000	2	50.4	172,000	2	75.6	258,000	2
460	13.8	47,100	1	27.5	93,900	1	41.3	141,000	2	55.1	188,000	2	82.7	282,200	2
480	15.0	51,200	1	30.0	102,400	1	45.0	153,600	2	60.0	204,800	2	90.0	307,100	2
550	12.6	43,000	1	25.2	86,000	1	37.8	129,000	2	50.4	172,000	2	75.6	258,000	2
575	13.8	47,100	1	27.5	93,900	1	41.3	141,000	2	55.1	188,000	2	82.7	282,200	2
600	15.0	51,200	1	30.0	102,400	1	45.0	153,600	2	60.0	204,800	2	90.0	307,100	2

## UNIT CLEARANCES

### Unit With Economizer

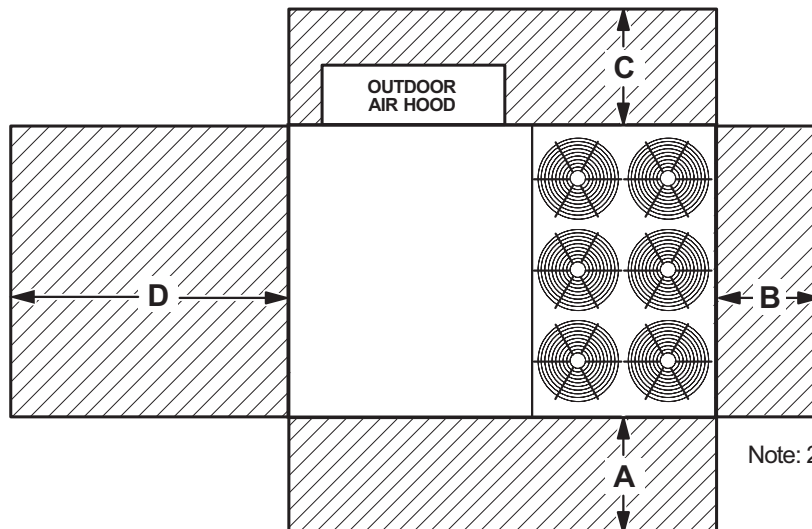

Note: 210-240-300 sizes shown

<sup>1</sup> Unit Clearance	A		B		C		D		Top Clearance
	in.	mm	in.	mm	in.	mm	in.	mm	
Service Clearance	60	1524	36	914	36	934	66	1676	Unobstructed
Minimum Operation Clearance	45	1143	36	914	36	914	41	1041	

NOTE - Entire perimeter of unit base requires support when elevated above the mounting surface.

<sup>1</sup> Service Clearance - Required for removal of serviceable parts.

Minimum Operation Clearance - Required clearance for proper unit operation.

## OUTDOOR SOUND DATA

Unit Model Number	Octave Band Sound Power Levels dB, re 10 <sup>-12</sup> Watts - Center Frequency - Hz							<sup>1</sup> Sound Rating Number (dBA)
	125	250	500	1000	2000	4000	8000	
156	71	78	81	81	76	71	63	86
180	80	83	87	88	84	80	71	93
210, 240, 300	79	84	88	89	85	82	73	94

Note - The octave sound power data does not include tonal corrections.

<sup>1</sup> Sound Rating Number according to AHRI Standard 370-2001 (includes pure tone penalty). Sound Rating Number is the overall A-Weighted Sound Power Level, (LWA), dBA (100 Hz to 10,000 Hz).



## WEIGHT DATA

Model Number	Outdoor Coil	Net		Shipping		Outdoor Coil	Net		Shipping	
		lbs.	kg	lbs.	kg		lbs.	kg		
156 Base Unit	Environ™	1785	810	1985	900	Fin/Tube	1850	839	2050	930
156 Max. Unit	Environ™	2065	937	2265	1027	Fin/Tube	2130	966	2330	1057
180 Base Unit	Environ™	1965	891	2165	982	Fin/Tube	2070	939	2270	1030
180 Max. Unit	Environ™	2245	1018	2445	1109	Fin/Tube	2350	1066	2550	1157
210 Base Unit	Environ™	2090	948	2290	1039	Fin/Tube	2180	989	2380	1080
210 Max. Unit	Environ™	2380	1080	2580	1170	Fin/Tube	2470	1120	2670	1211
240 Base Unit	Environ™	2175	987	2375	1077	Fin/Tube	2280	1034	2480	1125
240 Max. Unit	Environ™	2465	1118	2665	1209	Fin/Tube	2570	1166	2770	1256
300 Base Unit	Environ™	2300	1043	2500	1134	Fin/Tube	2365	1073	2565	1163
300 Max. Unit	Environ™	2590	1175	2790	1266	Fin/Tube	2655	1204	2855	1295

NOTE - Max. Unit is the unit with ALL INTERNAL OPTIONS Installed. (Economizer, Standard Static Power Exhaust Fans, Controls, etc.). Does not include accessories EXTERNAL to unit.

## OPTIONS / ACCESSORIES

Description	Shipping Weight	
	lbs.	kg
<b>CEILING DIFFUSERS</b>		
<b>Step-Down</b>		
	RTD11-185S	168
	RTD11-275S	238
<b>Flush</b>		
	FD11-185S	168
	FD11-275S	238
<b>Transitions</b>		
	C1DIFF33C-1	80
	C1DIFF34C-1	75

## ECONOMIZER / OUTDOOR AIR / EXHAUST

<b>Economizer</b>		
Economizer Dampers	102	46
Barometric Relief Dampers (downflow)	30	14
Barometric Relief Dampers (horizontal)	20	9
Outdoor Air Damper Hood (downflow)	65	29
<b>Outdoor Air Dampers</b>		
Outdoor Air Damper Section (downflow) - Automatic (including Hood)	18	39
Outdoor Air Damper Section (downflow) - Manual (including Hood)	10	22
<b>Power Exhaust</b>	62	28

## ELECTRIC HEAT

15 kW	59	27
30 kW	59	27
45 kW	76	34
60 kW	76	34
90 kW	84	38

## HUMIDITROL® DEHUMIDIFICATION SYSTEM

Humiditrol® Dehumidification Option (Net Weight)	50	23
--	----	----

## MSAV® (MULTI-STAGE AIR VOLUME) SUPPLY AIR BLOWER OPTION

Variable Frequency Drive (VFD) and associated components	10	5
--	----	---

## ROOF CURBS

<b>Hybrid Roof Curbs, Downflow</b>		
8 in. height	75	34
14 in. height	105	48
18 in. height	125	57
24 in. height	155	70
<b>Adjustable Pitch Curb, Downflow</b>		
14 in. height	262	119
<b>Horizontal, Standard</b>		
26 in. height	470	213
37 in. height	505	229
30 in. height	575	261
41 in. height	610	277

## PACKAGING

LTL Packaging (less than truck load)	Engergence® Packaged Electric / Electric 13 to 25 Ton / Page 55
--------------------------------------	---

**CORNER WEIGHTS**

**CENTER OF GRAVITY**

Model No.	AA		BB		CC		DD		EE		FF	
	lbs.	kg	lbs.	kg	lbs.	kg	lbs.	kg	in.	mm	in.	mm
LCH156 Base Unit (Environ™ Coil)	428	195	346	157	456	207	554	252	48-1/2	1232	39-1/2	1003
LCH156 Max. Unit (Environ™ Coil)	538	244	429	195	489	222	609	277	48	1219	42-3/4	1086
LCH156 Base Unit (Fin/Tube Coil)	431	195	376	171	486	220	557	253	50-1/4	1276	39-3/4	1010
LCH156 Max. Unit (Fin/Tube Coil)	540	245	459	208	519	235	611	277	49-1/2	1257	42-3/4	1086

Base Unit - The unit with NO INTERNAL OPTIONS.

Max. Unit - The unit with ALL INTERNAL OPTIONS Installed. (Economizer, Standard Static Power Exhaust Fans, Controls, etc.). Does not include accessories external to unit.

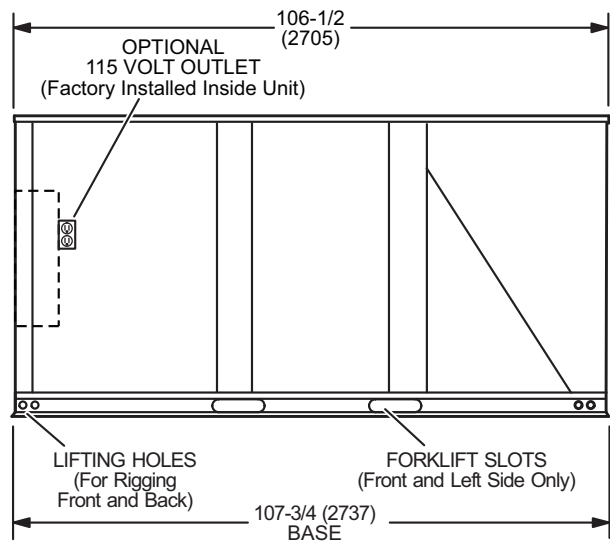
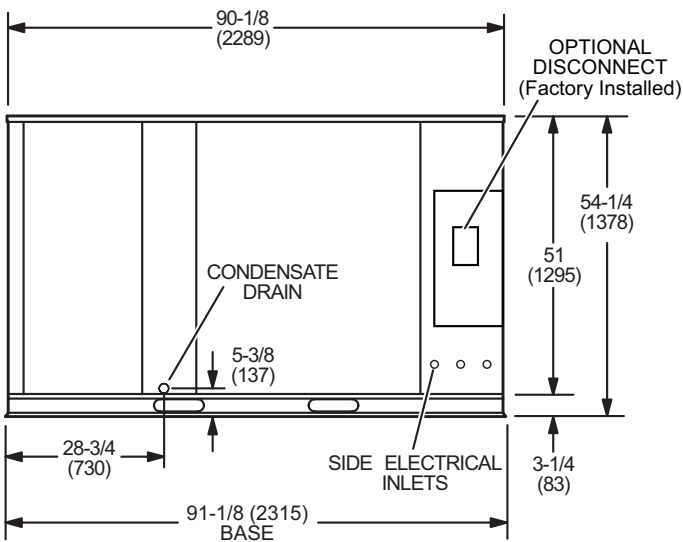
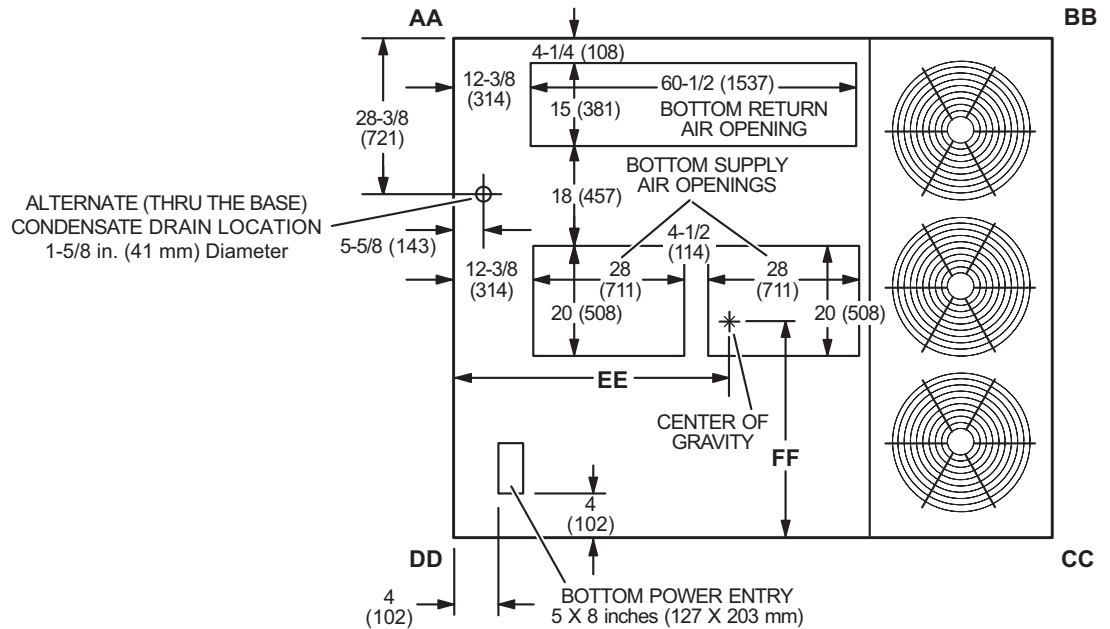

# DIMENSIONS - UNIT

LCH180

## CORNER WEIGHTS

## CENTER OF GRAVITY

Model No.	AA		BB		CC		DD		EE		FF	
	lbs.	kg	lbs.	kg	lbs.	kg	lbs.	kg	in.	mm	in.	mm
LCH180 Base Unit (Environ™ Coil)	441	201	403	183	543	247	577	262	52	1321	39-1/4	997
LCH180 Max. Unit (Environ™ Coil)	545	248	485	221	577	262	638	290	51	1295	42	1067
LCH180 Base Unit (Fin/Tube Coil)	441	200	456	207	596	270	577	262	54-3/4	1391	39-1/2	1003
LCH180 Max. Unit (Fin/Tube Coil)	545	247	538	244	629	285	638	289	53-1/2	1359	42	1067

Base Unit - The unit with NO INTERNAL OPTIONS.

Max. Unit - The unit with ALL INTERNAL OPTIONS Installed. (Economizer, Standard Static Power Exhaust Fans, Controls, etc.). Does not include accessories external to unit.

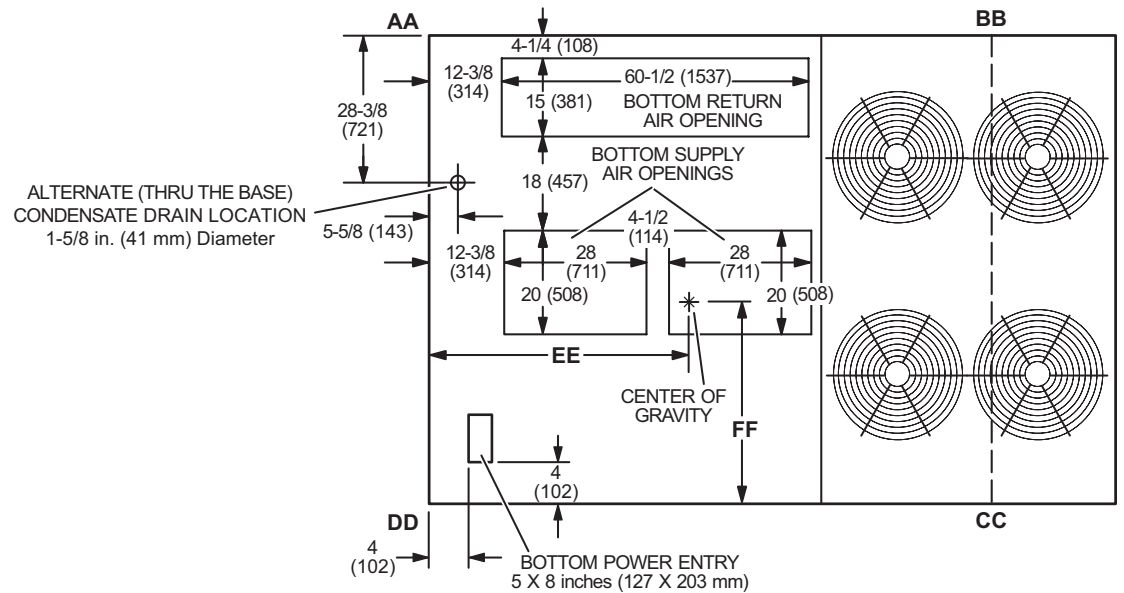

TOP VIEW

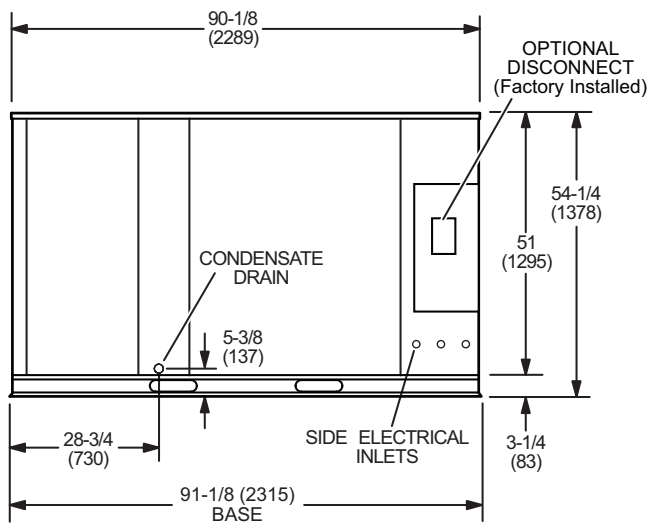

END VIEW

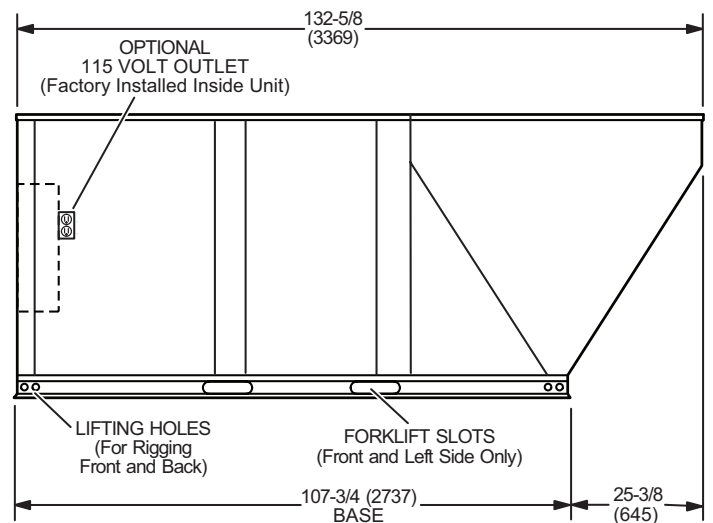

SIDE VIEW

**DIMENSIONS - UNIT**

**LCH210 | LCH240 | ICH300**

**CORNER WEIGHTS**

**CENTER OF GRAVITY**

Model No.	AA		BB		CC		DD		EE		FF	
	lbs.	kg	lbs.	kg	lbs.	kg	lbs.	kg	in.	mm	in.	mm
LCH210 Base Uni (Environ™ Coil)	452	205	448	204	600	273	590	268	54	1372	39-1/4	997
LCH210 Max. Unit (Environ™ Coil)	557	253	536	244	635	288	652	296	53	1346	42	1067
LCH210 Base Unit (Fin/Tube Coil)	452	205	493	224	645	293	590	268	56-1/4	1429	39-1/2	1003
LCH210 Max. Unit (Fin/Tube Coil)	557	253	581	264	680	308	652	296	55	1397	42	1067
LCH240 Base Unit (Environ™ Coil)	462	210	461	210	634	288	617	281	54-1/2	1384	38-3/4	984
LCH240 Max. Unit (Environ™ Coil)	568	258	550	250	668	304	679	308	53-1/2	1359	41-1/2	1054
LCH240 Base Unit (Fin/Tube Coil)	462	210	514	233	687	312	617	280	56-3/4	1441	39	991
LCH240 Max. Unit (Fin/Tube Coil)	568	258	603	274	721	327	679	308	55-1/2	1410	41-1/2	1054
LCH300 Base Unit (Environ™ Coil)	466	212	487	221	689	313	660	300	55	1397	37-3/4	959
LCH300 Max. Unit (Environ™ Coil)	574	261	578	263	723	329	718	326	54	1372	40-1/2	1029
LCH300 Base Unit (Fin/Tube Coil)	469	213	518	235	724	329	656	298	56-1/2	1435	38	965
LCH300 Max. Unit (Fin/Tube Coil)	575	261	606	275	758	344	719	327	55-1/4	1403	40-1/2	1029

Base Unit - The unit with NO INTERNAL OPTIONS.

Max. Unit - The unit with ALL INTERNAL OPTIONS Installed. (Economizer, Standard Static Power Exhaust Fans, Controls, etc.). Does not include accessories external to unit.

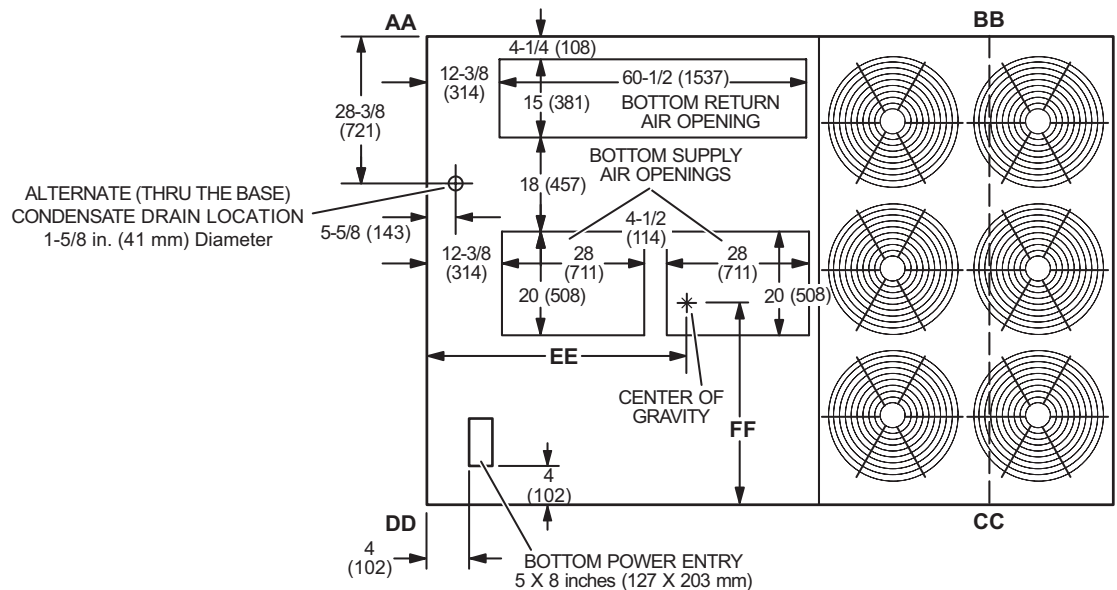

**TOP VIEW**

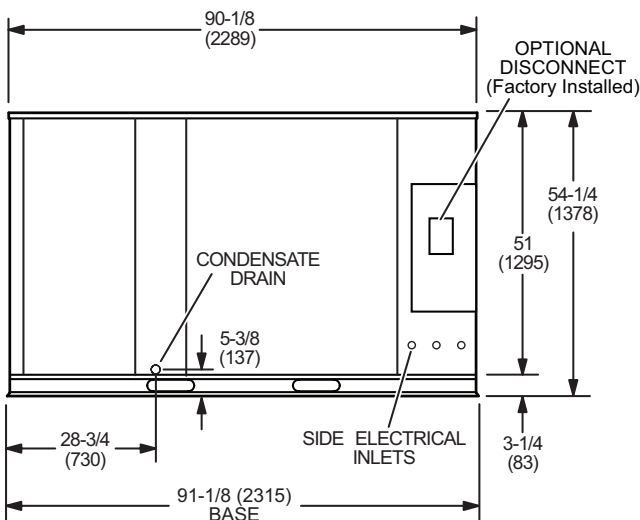

**END VIEW**

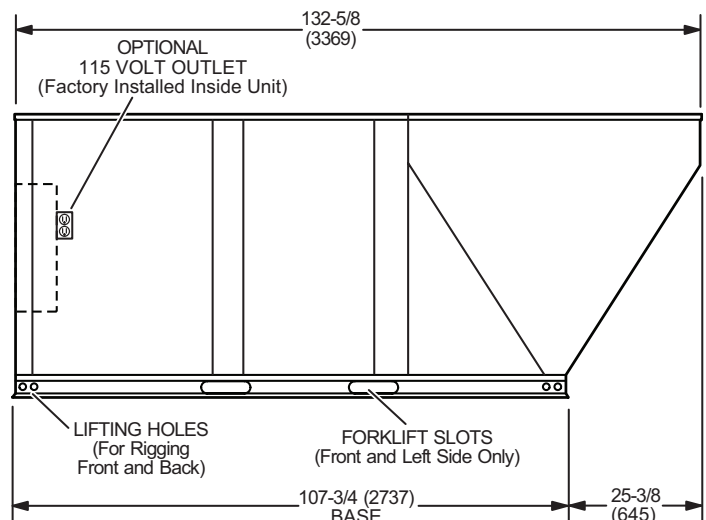

**SIDE VIEW**

**OUTDOOR AIR HOOD DETAIL**

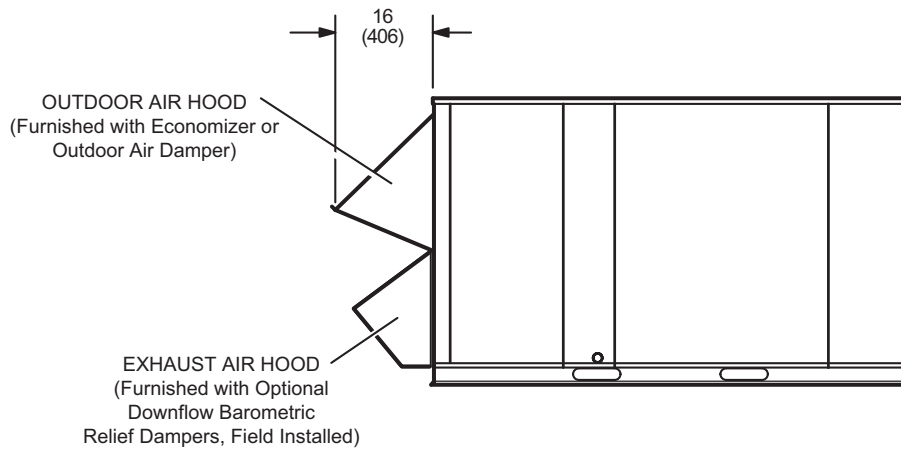

**OPTIONAL HORIZONTAL BAROMETRIC RELIEF DAMPERS WITH HOOD**

(Field installed in horizontal return air duct adjacent to unit)

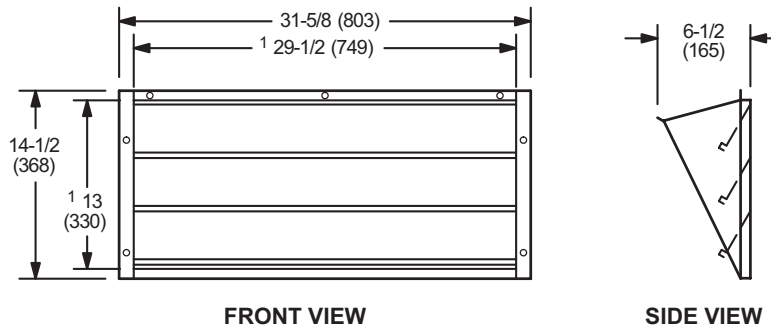

NOTE - Two furnished per order no.  
<sup>1</sup> NOTE - Opening size required in return air duct.

# DIMENSIONS - ACCESSORIES

## HYBRID ROOF CURBS - DOUBLE DUCT OPENING

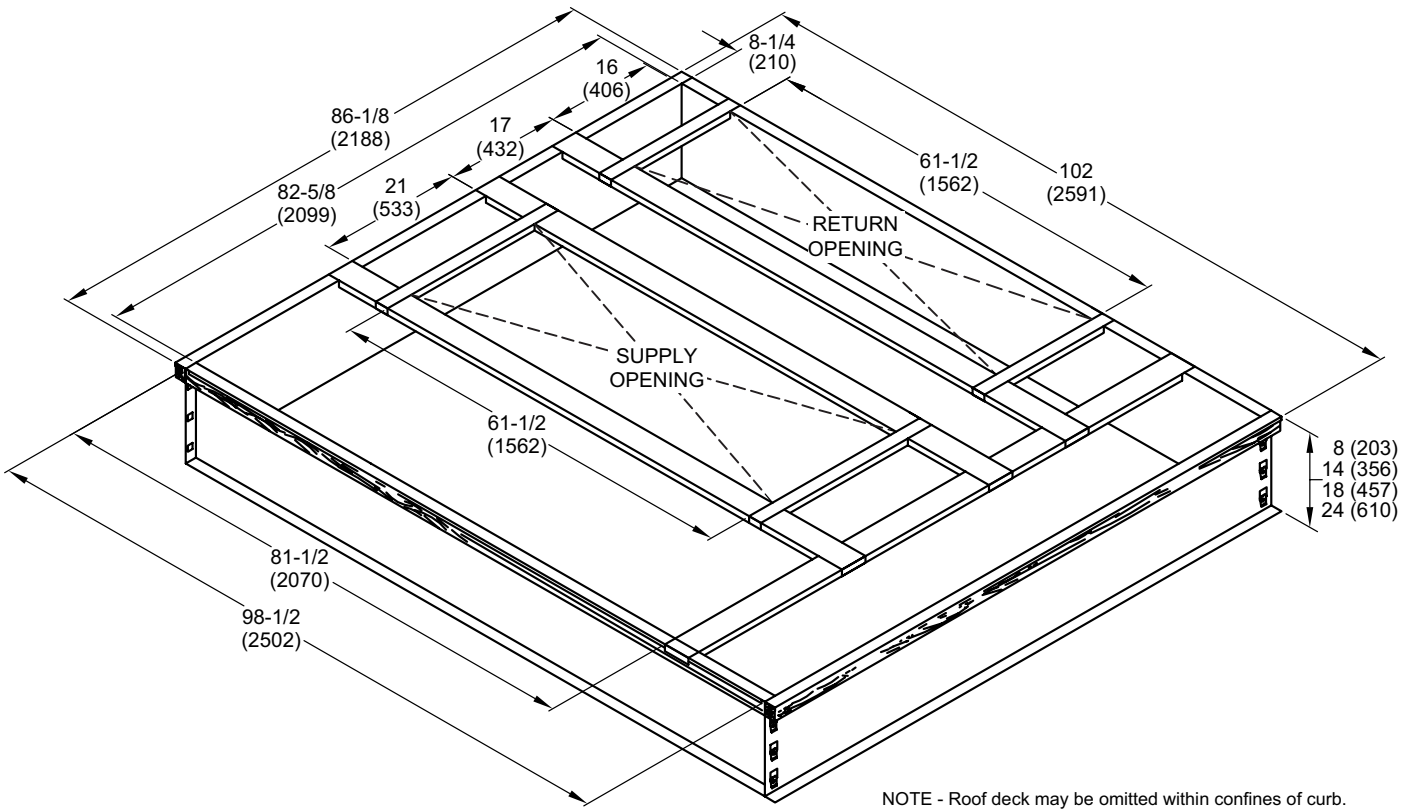

**TYPICAL FLASHING DETAIL FOR ROOF CURB**

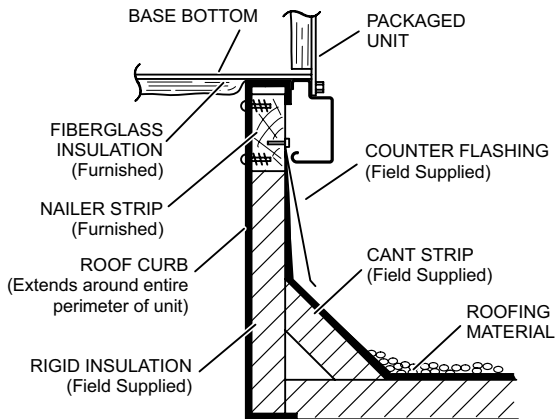

**DETAIL ROOF CURB**

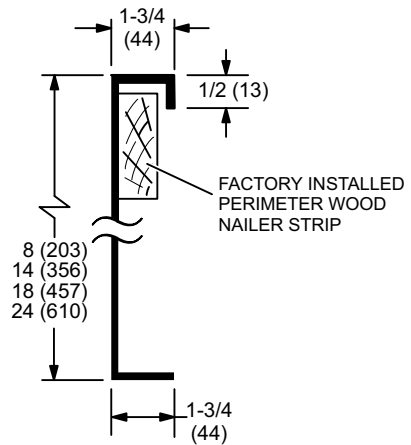



# DIMENSIONS - ACCESSORIES

## ADJUSTABLE PITCH CURB - DOUBLE DUCT OPENING

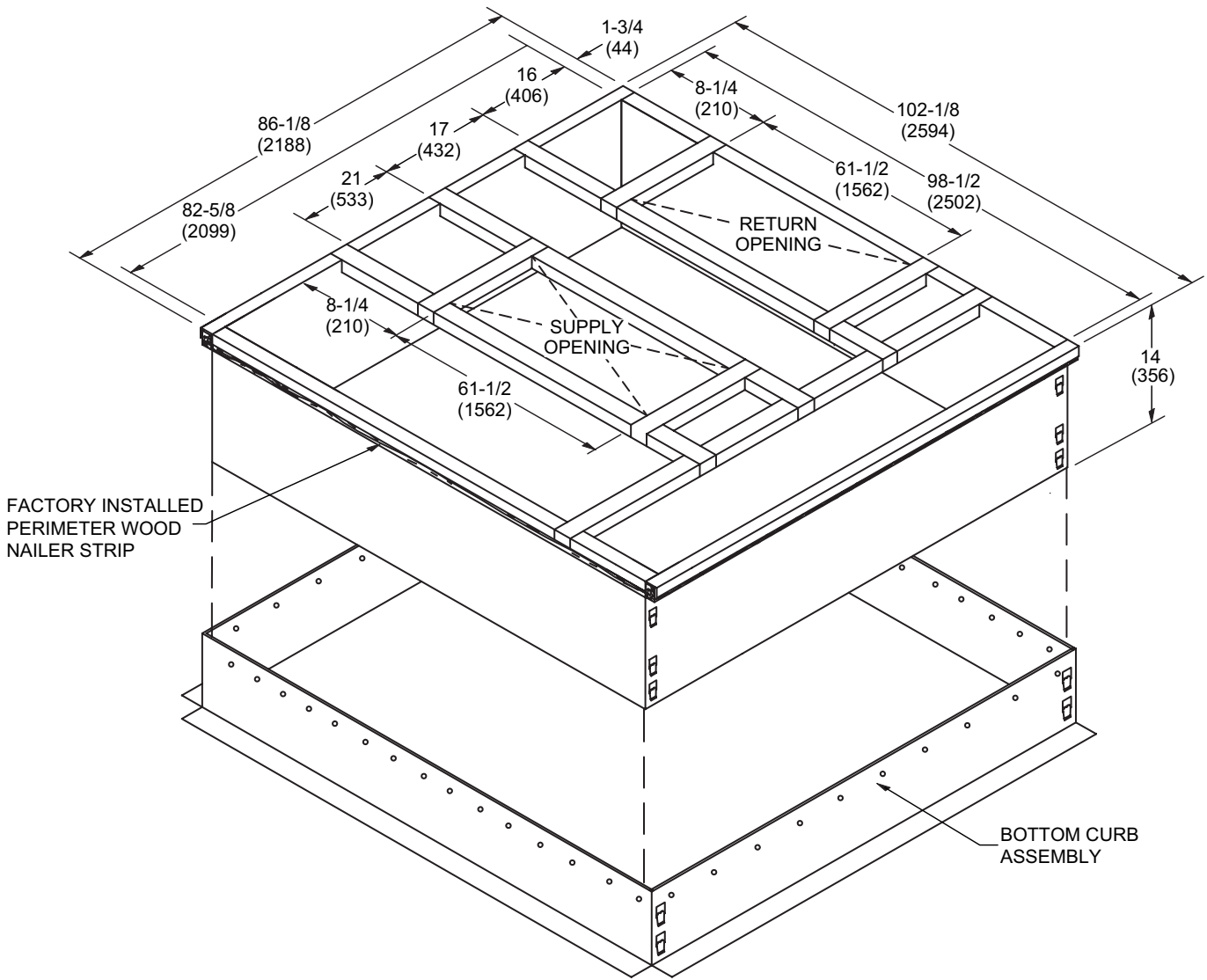

NOTE - Maximum slope pitch is 3/4 in. per 1 foot (19 mm per 305 mm) in any one direction.

### TYPICAL FLASHING DETAIL FOR ROOF CURB

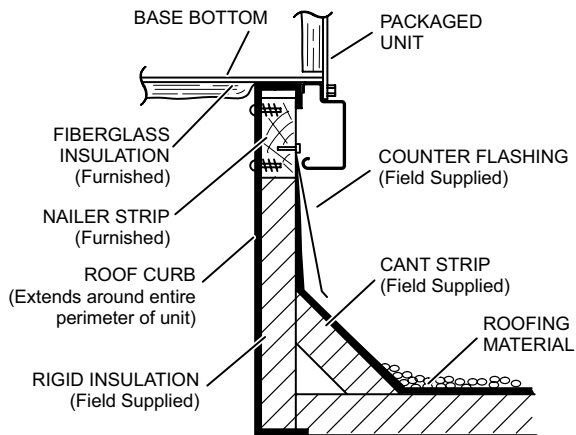

### DETAIL ROOF CURB

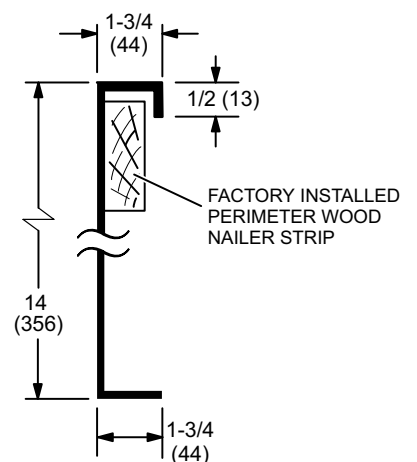

## DIMENSIONS - ACCESSORIES

### ROOF CURBS WITH SUPPLY & RETURN AIR TRANSITIONS FOR CEILING DIFFUSERS

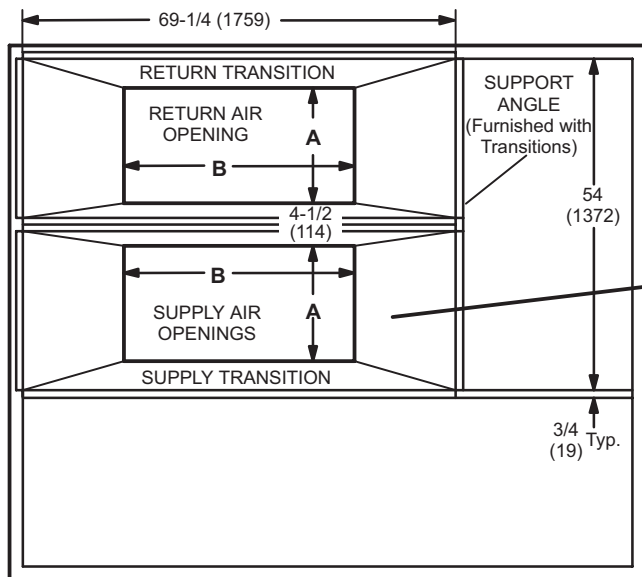

TOP VIEW

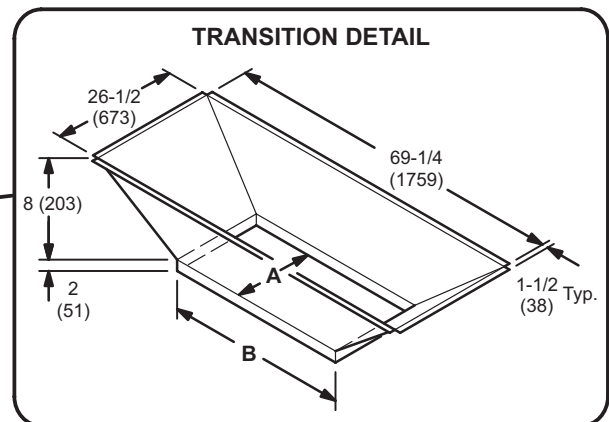

TRANSITION OPENING SIZES

Model Number	A		B	
	inch	mm	inch	mm
C1DIFF33C-1	18	457	36	914
C1DIFF34C-1	24	610	48	1219

# DIMENSIONS - ACCESSORIES

## HORIZONTAL ROOF CURBS – Requires Optional Horizontal Return Air Panel Kit

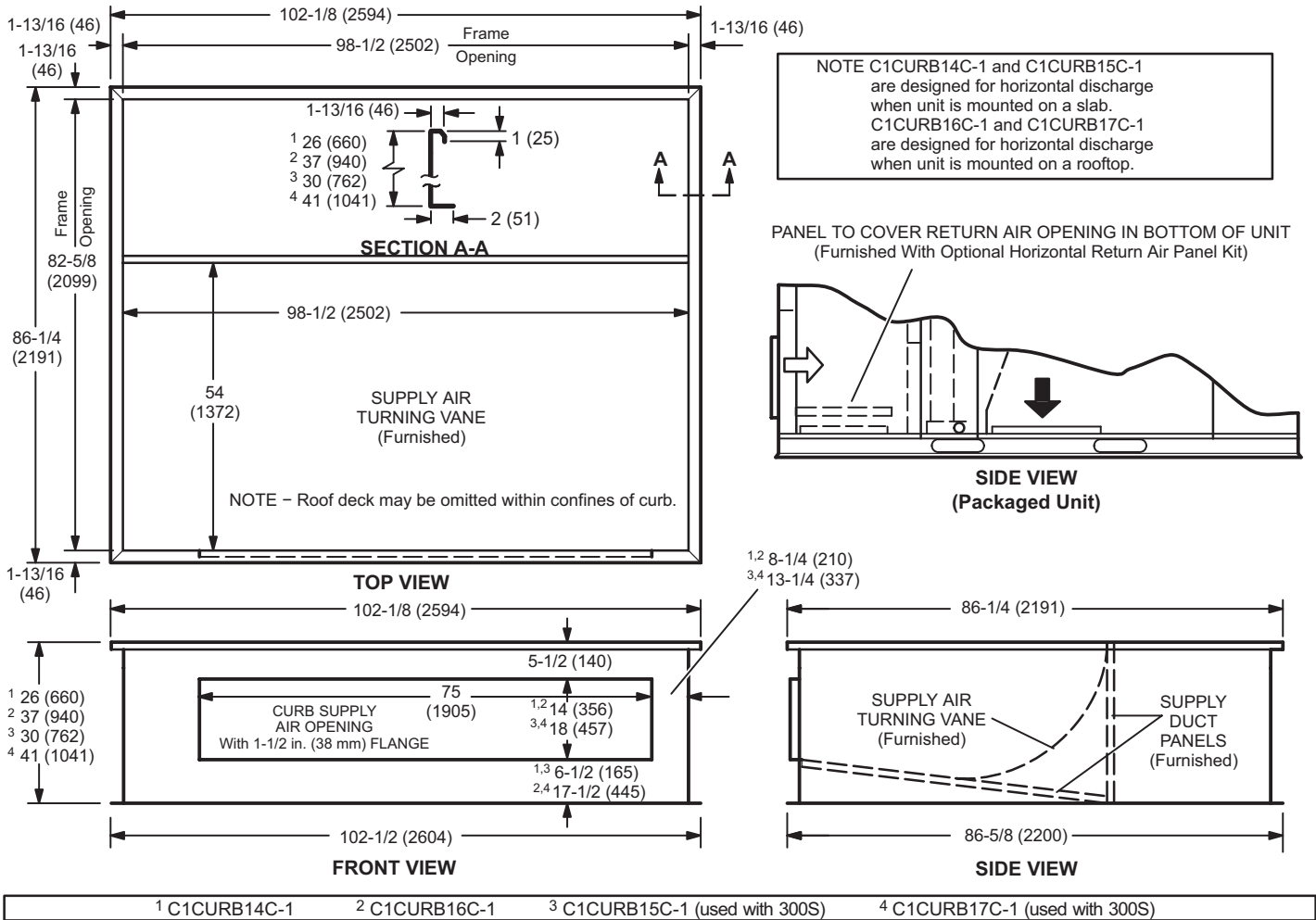

## HORIZONTAL SUPPLY AND RETURN AIR OPENINGS WITH HORIZONTAL ROOF CURB

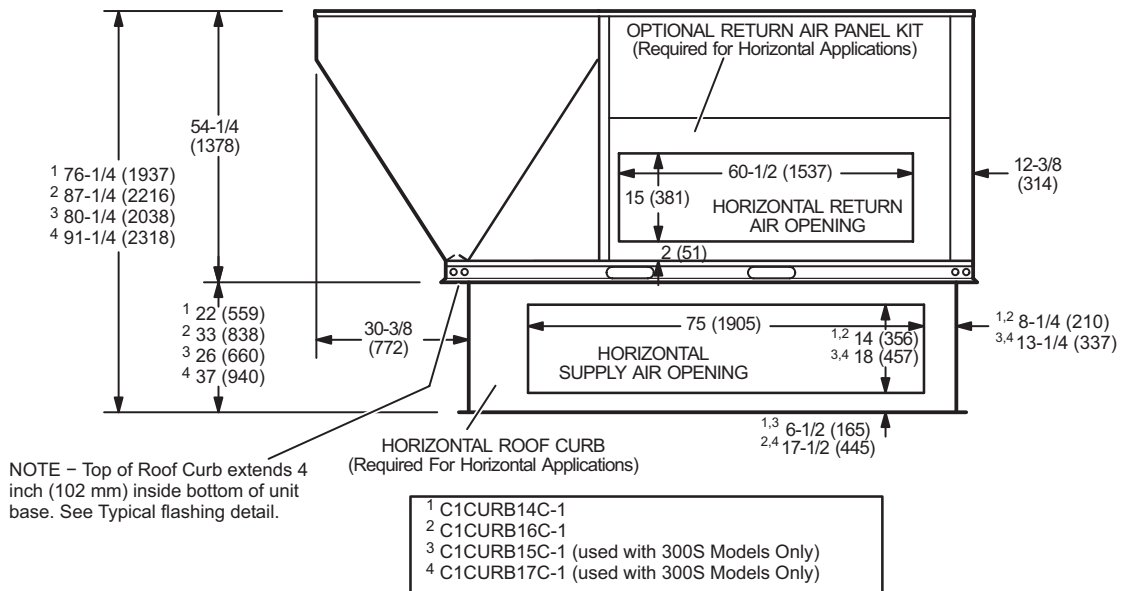

## DIMENSIONS - ACCESSORIES

### COMBINATION CEILING SUPPLY AND RETURN DIFFUSERS

#### STEP-DOWN CEILING DIFFUSER

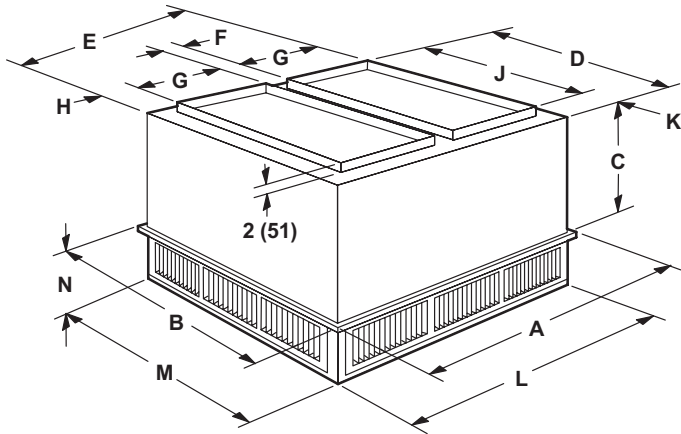

#### FLUSH CEILING DIFFUSER

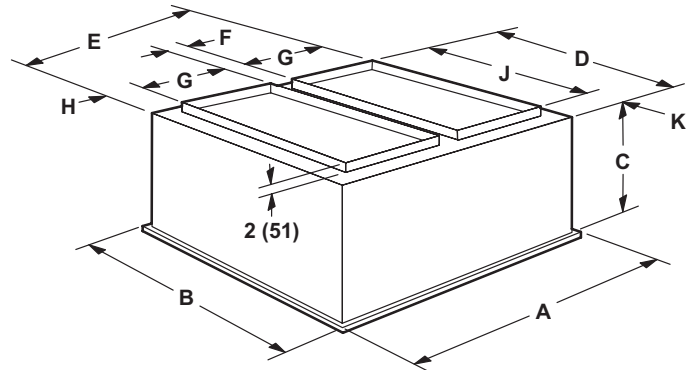

Model Number		RTD11-185S	RTD11-275S
<b>A</b>	in.	47-5/8	59-5/8
	mm	1210	1514
<b>B</b>	in.	47-5/8	59-5/8
	mm	1210	1514
<b>C</b>	in.	24-5/8	30-5/8
	mm	625	778
<b>D</b>	in.	45-1/2	57-1/2
	mm	1156	1461
<b>E</b>	in.	45-1/2	57-1/2
	mm	1156	1461
<b>F</b>	in.	4-1/2	4-1/2
	mm	114	114
<b>G</b>	in.	18	24
	mm	457	610
<b>H</b>	in.	2-1/2	2-1/2
	mm	64	64
<b>J</b>	in.	36	48
	mm	914	1219
<b>K</b>	in.	4-3/4	4-3/4
	mm	121	121
<b>L</b>	in.	45-1/2	57-1/2
	mm	1156	1461
<b>M</b>	in.	45-1/2	57-1/2
	mm	1156	1461
<b>N</b>	in.	10-1/8	11-1/8
	mm	257	283
<b>Duct Size</b>	in.	18 x 36	24 x 48
	mm	457 x 914	610 x 1219

Model Number		FD11-185S	FD11-275S
<b>A</b>	in.	47-5/8	59-5/8
	mm	1210	1514
<b>B</b>	in.	47-5/8	59-5/8
	mm	1210	1514
<b>C</b>	in.	29-1/4	35-1/4
	mm	743	895
<b>D</b>	in.	45	57
	mm	1143	1148
<b>E</b>	in.	45	57
	mm	1143	1448
<b>F</b>	in.	4-1/2	4-1/2
	mm	114	114
<b>G</b>	in.	18	24
	mm	457	610
<b>H</b>	in.	2-1/4	2-1/4
	mm	57	57
<b>J</b>	in.	36	48
	mm	914	1219
<b>K</b>	in.	4-1/2	4-1/2
	mm	114	114
<b>Duct Size</b>	in.	18 x 36	24 x 48
	mm	457 x 914	610 x 1219









## REVISIONS

Section	Description
Electrical Accessories - Disconnects	Updated for 208/240V models.

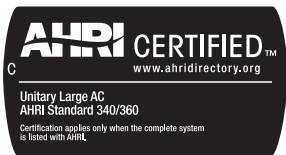

Visit us at [www.lennox.com](http://www.lennox.com)

For the latest technical information, [www.lennoxcommercial.com](http://www.lennoxcommercial.com)

Contact us at 1-800-4-LENNOX

NOTE - Due to Lennox' ongoing commitment to quality, Specifications, Ratings and Dimensions subject to change without notice and without incurring liability. Improper installation, adjustment, alteration, service or maintenance can cause property damage or personal injury. Installation and service must be performed by a qualified installer and servicing agency.

©2020 Lennox Industries, Inc.