



LCH

**Energence® Rooftop Units
High Efficiency - 60 Hz**

**COMMERCIAL
PRODUCT SPECIFICATIONS**

Bulletin No. 210608
March 2021
Supersedes June 2020



SMART WIRE™ SYSTEM



**20 to 30 Tons
Net Cooling Capacity – 238,000 to 354,000 Btuh
Optional Electric Heat - 30 to 120 kW**

MODEL NUMBER IDENTIFICATION

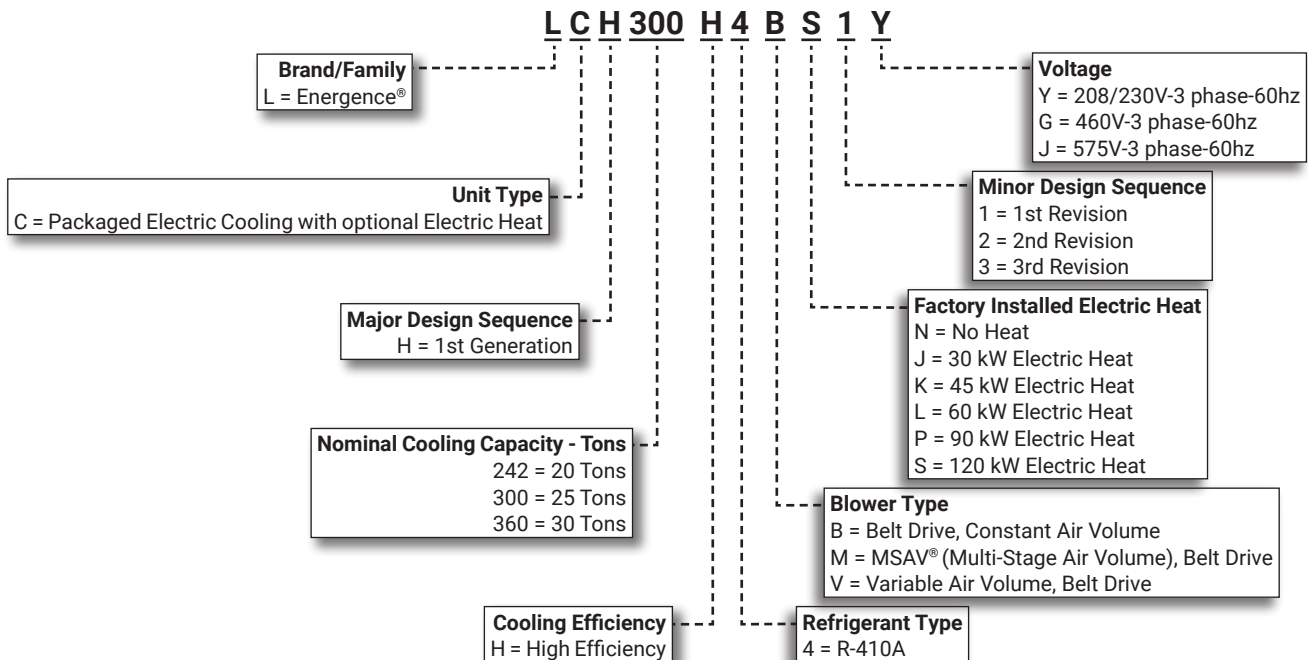

FEATURE HIGHLIGHTS

Lennox' Energence® packaged rooftop unit product line was created to save energy with intelligence by offering some of the highest energy efficiency ratings available with a powerful, easy to use unit controller. This makes Energence rooftop units perfect for business owners looking for an HVAC product with the lowest total cost of ownership.

1. Scroll Compressors
2. Lennox' Environ™ Coil System
3. Thermal Expansion Valves
4. Filters/Driers
5. Outdoor Coil Fan Motors
6. Heavy Gauge Steel Cabinet
7. Hinged Access Panels
8. Constant, Variable or Multi-Stage Air Volume (MSAV®) Blower
9. Electric Heat (option)
10. Air Filters
11. Prodigy® Control System
12. Economizer (option)
13. Downflow Barometric Relief Dampers (option)
14. Power Exhaust
15. Humiditrol® Dehumidification (option)

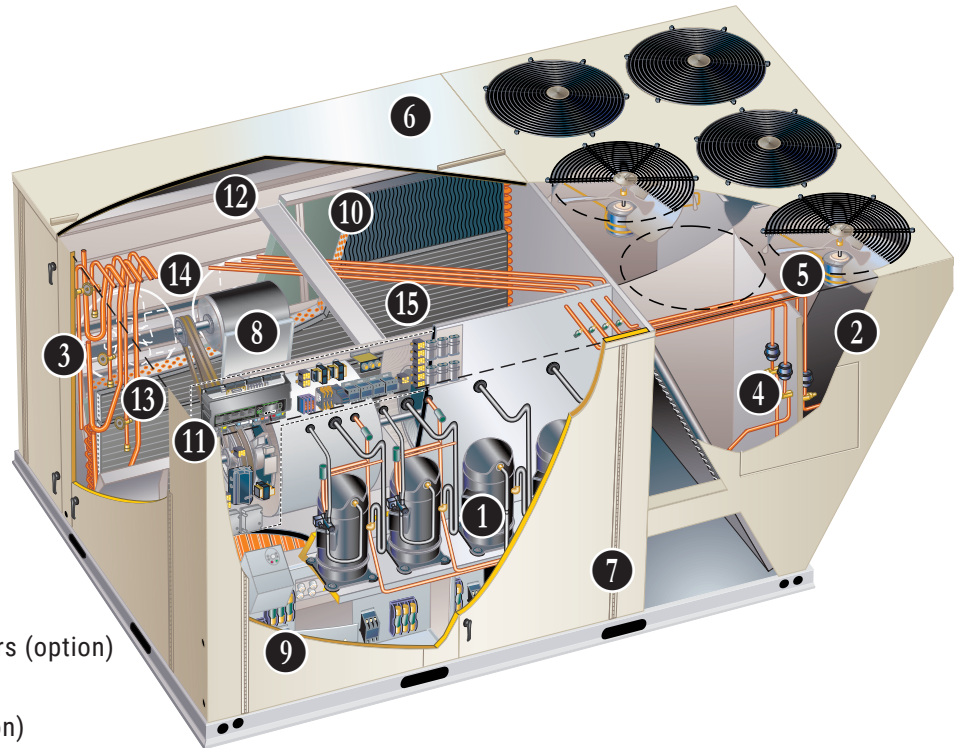

CONTENTS

Approvals And Warranty	3
Blower Data	35
Control System	7
Dimensions - Accessories	55
Dimensions - Unit	54
Electrical Accessories	49
Electrical Data	43
Features And Benefits	3
Humiditrol® Dehumidification System Option	12
Humiditrol® Dehumidification System Ratings	34
Model Number Identification	1
Optional Conventional Temperature Control Systems	14
Options / Accessories	23
Outdoor Sound Data	53
Ratings	29
Sequence Of Operation	16
Specifications	27
Unit Clearances	51
Weight Data	53

APPROVALS AND WARRANTY

APPROVALS

- AHRI Standard 340/360 certified (242 models)
- Tested at conditions included in AHRI Standard 340/360 (300 and 360 models)
- ETL and CSA listed
- CSA certified energy ratings
- Unit and components ETL, NEC and CEC bonded for grounding to meet safety standards for servicing
- All models are ASHRAE 90.1-2010 energy efficiency compliant and meet or exceed requirements of Section 6.8
- All models meet DOE 2018 energy efficiency standards
- MSAV models meet California Code of Regulations, Title 24 and ASHRAE 90.1-2010 Section 6.4.3.10 requirements for staged airflow
- ENERGY STAR® certified
- ISO 9001 Registered Manufacturing Quality System

WARRANTY

- Compressors - Limited five years
- Lennox' Environ™ Coil System - Limited three years
- Prodigy® 2.0 Unit Controller - Limited three years
- High Performance Economizers (optional) - Limited five years
- All other covered components - Limited one year

FEATURES AND BENEFITS

COOLING SYSTEM

- Designed to maximize sensible and latent cooling performance at design conditions
- System can operate from 0°F to 125°F without any additional controls

R-410A Refrigerant

- Non-chlorine based
- Ozone friendly

1 Scroll Compressors

- Scroll compressors on all models for high performance, reliability and quiet operation
- Resiliently mounted on rubber grommets for quiet operation

Compressor Crankcase Heaters

- Protects against refrigerant migration that can occur during low ambient operation or during extended off cycles

2 Condenser Coil - Lennox' Environ™ Coil System

- Lightweight, all aluminum brazed fin construction
- Constructed of three components
 - A flat extrusion tube
 - Fins in-between the flat extrusion tube
 - Two refrigerant manifolds

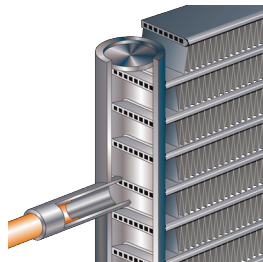

Environ™ Coil System Features:

- Improved heat transfer performance due to high primary surface area (flat tubes) versus secondary surface (fins)
- Smaller internal volume (reduced refrigerant charge)
- High durability

- All aluminum construction
- Fewer brazed joints
- Compact design
- Reduced unit weight
- Easy maintenance/cleaning
- Face split design
- Mounting brackets with rubber inserts
- Angled cabinet design protects coil from damage

Evaporator Coil

- Copper tube construction
- Enhanced rippled-edge aluminum fins
- Flared shoulder tubing connections
- Silver soldered construction
- Factory leak tested
- Cross row circuiting with rifled tubing

NOTE - Constant air volume (CAV) and MSAV® (Multi-Stage Air Volume) models have face-split evaporator coils designed to keep condensate water off of an inactive part of the coil so the condensate will not re-enter the air stream. Variable air volume (VAV) models have row-split, intertwined evaporator coils.

3 Thermal Expansion Valves

- Assures optimal performance throughout the application range
- Removable element head

4 Filter/Driers

- High capacity filter/drier protects the system from dirt and moisture

FEATURES AND BENEFITS

COOLING SYSTEM (continued)

High Pressure Switches

Protects the compressor from overload conditions such as dirty condenser coils, blocked refrigerant flow, or loss of outdoor fan operation

Low Pressure Switches

- Protects the compressors from low pressure conditions such as low refrigerant charge, or low/no airflow

Condensate Drain Pan

- Plastic pan, sloped to meet drainage requirements of ASHRAE 62.1
- Side drain connections

NOTE - Stainless steel drain pan available as a factory installed option.

Freezestats

- Protects the evaporator coil from damaging ice build-up due to conditions such as low/no airflow, or low refrigerant charge

5 Outdoor Coil Fan Motors

- Thermal overload protected
- Totally enclosed
- Permanently lubricated ball bearings
- Shaft up
- Wire basket mount

Outdoor Coil Fans

- PVC coated fan guard furnished

Required Selections

Cooling Capacity

- Specify nominal cooling capacity

Options/Accessories

Factory Installed

Discharge Air Temperature Sensor

- Sensor sends information to the unit controller to cycle up to 2 stages of heating or 4 stages of cooling to maintain the discharge air setpoints for heating or cooling
- Optional for CAV units (single zone or bypass zoning control)

NOTE - Automatically furnished with all Variable Air Volume (VAV) units. Sensor is shipped with the unit for remote field installation in the supply duct

Factory or Field Installed

Condensate Drain Trap

- Available in copper or PVC
- Field installed only, may be factory ordered to ship with unit

Drain Pan Overflow Switch

- Monitors condensate level in drain pan
- Shuts down unit if drain becomes clogged

Stainless Steel Drain Pan

- Non-corrosive drain pan

CABINET

6 Construction

- Heavy-gauge steel panels
- Full perimeter heavy-gauge galvanized steel base rail
- Base rails have rigging holes
- Three sides of the base rail have forklift slots
- Raised edges around duct and power entry openings in the bottom of the unit for water protection

Airflow Choice

- Units are shipped in downflow (vertical) return air flow configuration

NOTE - Units can be field converted to horizontal air flow with optional Horizontal Return Air Panel Kit and Horizontal Roof Curb.

Power Entry

- Electrical lines can be brought through the unit base or through horizontal access knock-outs

Exterior Panels

- Constructed of heavy-gauge, galvanized steel
- Two-layer enamel paint finish

Insulation

- Fully insulated with non-hygroscopic fiberglass insulation (conditioned areas)
- Unit base is fully insulated
- Base insulation serves as an air seal to the roof curb, eliminating the need to add a seal during installation

7 Hinged Access Panels

- Filter section
- Blower section
- Heating section
- Compressor/controls section
- Panel seals and quarter-turn latching handles provide a tight air and water seal

Options/Accessories

Factory Installed

Corrosion Protection

- Completely flexible immersed coating
- Electrodeposited dry film process
- AST ElectroFin E-Coat
- Meets Mil Spec MIL-P-53084, ASTM B117 Standard Method Salt Spray Testing
- Indoor Corrosion Protection:
 - Coated coil
 - Coated reheat coil (Humiditrol®)
 - Painted blower housing
 - Painted base
- Outdoor Corrosion Protection:
 - Coated coil
 - Painted outdoor base

FEATURES AND BENEFITS

CABINET (continued)

Field Installed

Combination Coil/Hail Guards

- Heavy gauge steel frame
- Painted to match cabinet
- Expanded metal mesh protects outdoor coil

Grille Guards

- Protects the space between outdoor coils and main cabinet

Horizontal Return Air Panel Kit

- Required for horizontal applications with Horizontal Roof Curb
- Contains panel with return air opening for field replacement of existing unit panel and panel to cover bottom return air opening in unit
- See dimension drawings

BLOWER

- A wide selection of supply air blower options are available to meet a variety of airflow requirements

8 Motor

- Overload protected
- Ball bearings
- Belt drive motors are offered on all models and are available in several different sizes to maximize air performance

NOTE - All blower motors 5 hp and above meet minimum energy efficiency standards in accordance with the Energy Independence and Security Act (EISA) of 2007

Supply Air Blower

- Forward curved blades
- Double inlet
- Blower wheel statically and dynamically balanced
- Ball bearings
- Adjustable pulley (allows speed change)
- Blower assembly slides out of unit for servicing
- Grease fittings furnished

Supply Static Pressure Transducer (VAV Models Only)

- Sends information to the Prodigy® 2.0 unit controller to control VFD blower speed
- Shipped with the unit for remote field installation in the supply duct

Required Selections

Supply Air Blower Selection

- Specify Constant Air Volume (CAV), Variable Air Volume (VAV) or MSAV® (Multi-Stage Air Volume).
- Constant Air Volume (CAV) models supply a constant volume of air
- Variable Air Volume (VAV) variable frequency drive (VFD) varies the air volume to maintain a constant duct static pressure
- MSAV (Multi-Stage Air Volume) models stage the amount of airflow according to compressor stages, heating demand, ventilation demand or smoke alarm

- Utilizes a Variable Frequency Drive (VFD) to stage the supply air blower airflow
- VFD alters the frequency and voltage of the power supply to the blower to control blower speed
- The amount of airflow for each stage can be set according to a parameter in the Prodigy® 2.0 unit controller
- Unit is shipped from the factory with preset airflows
- The MSAV supply air blower option can be ordered with or without an Electronic Bypass Control
- If equipped with the bypass control the MSAV features automatic electronic bypass control of the VFD
- In case of a VFD malfunction, a VFD alarm is generated by the Prodigy® 2.0 unit controller
- Unit controller will automatically switch to full blower speed if a VFD alarm is generated
- VFD has an operational range of 0 to 125° F outdoor air ambient temperature
- Lower operating costs are obtained when the blower is operated on lower speeds

NOTE - Units equipped a Variable Frequency Drive (VFD) are designed to operate on balanced, three-phase power. Operating units on unbalanced three-phase power will reduce the reliability of all electrical components in the unit. Unbalanced power is a result of the power delivery system supplied by the local utility company. Factory-installed inverters are sized to drive blower motors with an equivalent current rating using balanced three-phase power. If unbalanced three-phase power is supplied; the installer must replace the existing factory-installed inverter with an inverter that has a higher current rating to allow for the imbalance. Refer to the installation instructions for additional information and replacement information.

Ordering Information

- Specify motor horsepower and drive kit number when base unit is ordered

Options/Accessories

Factory Installed

Blower Belt Auto-Tensioner

- Provides proper tension to belt drive blower belt without the need for regular adjustments. Maintains airflow and proper performance.

Supply VFD Blower Bypass Control

- Allows MSAV or VAV units to operate as a constant air volume (CAV) unit in case of variable frequency drive (VFD) failure

NOTE - Bypass control for VAV models is a manual operation only. All supply air duct registers must be opened manually before operating bypass control.

Field Installed

Supply Static Limit Switch

- Manual reset switch for supply static high pressure limit
- Prevents exceeding pressure limit in supply air duct
- Optional Mounting Kit includes tubing and adaptors

FEATURES AND BENEFITS

ELECTRICAL

NOTE - All units include terminal block and fuse block in power entry junction box for single power entry application.

SmartWire™ System

- Keyed and color-coded wiring connectors prevent miswiring
- Wire coloring scheme is standardized across all models
- Each connection is intuitively labeled to make troubleshooting and servicing quick and easy

Electrical Plugs

- Positive connection electrical plugs connect common accessories or maintenance parts for easy removal or installation

Required Selections

Voltage Choice

- Specify when ordering base unit

Options/Accessories

Factory Installed

Circuit Breakers

- HACR type
- Overload and short circuit protection
- Factory wired and mounted in the power entry panel
- Current sensitive and temperature activated
- Manual reset

SCR (Silicon Controlled Rectifier) Electric Heat Control

- Modulates small, precise increments of power to the electric heat load eliminating temperature fluctuations associated with mechanical controls
- Almost instantaneous operation with no moving parts
- Zero-Cross (fast cycling) feature improves electric heater life with less contraction and expansion of the heating elements
- The SCR operates when there is no call for heat from the building control system or thermostat
- SCR air tempering is controlled by a secondary thermostat and remote duct sensor (ordered separately)
- A call for heat overrides the SCR and modulates the SCR to 100% heat output
- A call for cooling overrides the SCR

NOTE - SCR option is not available with 45 kW, 60 kW and 90kW electric heat (208/230V) models.

NOTE - Blower Proving Switch is required and must be ordered separately for factory installation. See Controls in the Options/Accessories table.

NOTE - Available for use with conventional thermostat controls or NoVar® control systems only.

Phase/Voltage Detection (Optional for CAV Models Only)

- Monitors power supply to assure phase is correct at unit start-up
- If phase is incorrect, the unit will not start and an alarm code is reported to the unit controller

- Protects unit from being started with incorrect phasing which could lead to issues such as compressors running backwards
- Voltage detection monitors power supply voltage to assure proper voltage
- If voltage is not correct (over/under voltage conditions) the unit will not start and an alarm code is reported to the unit controller

NOTE - Phase/voltage detection is furnished when the MSAV® (Multi-Stage Air Volume) or VAV (Variable Air Volume) option is ordered.

Factory or Field Installed

Disconnect Switch

- Accessible outside of unit
- Spring loaded weatherproof cover furnished

9 Electric Heat

- Helix wound nichrome elements
- Individual element limit controls
- Wiring harness
- Unit fuse block
- See Options/Accessories tables for ordering information

GFI Service Outlets (2)

- 115V ground fault circuit interrupter (GFCI) type
- Available non-powered, field-wired or factory-wired and powered

Field Installed

GFI Weatherproof Cover

- Single-gang cover
- Heavy-duty UV-resistant polycarbonate case construction
- Hinged base cover with gasket

INDOOR AIR QUALITY

10 Air Filters

- Disposable 2 inch filters furnished as standard

Options/Accessories

Factory or Field Installed

Healthy Climate® High Efficiency Air Filters

- Disposable MERV 8 or MERV 13 (Minimum Efficiency Reporting Value based on ASHRAE 52.2) efficiency 2-inch pleated filters

Replacement Filter Media Kit With Frame

- Replaces existing pleated filter media
- Includes washable metal mesh screen and metal frame with clip for holding replaceable non-pleated filter

Field Installed

Indoor Air Quality (CO₂) Sensors

- Monitors CO₂ levels, reports to the Prodigy® 2.0 unit controller which adjusts economizer dampers as needed

CONTROL SYSTEM

PRODIGY® CONTROL SYSTEM



11 The Prodigy 2.0 unit controller is a microprocessor-based controller that provides flexible control of all unit functions.

Features:

- LCD Display
- Easy to read menu (4 lines x 20 character display)
- Buttons for menu navigation during setup and diagnostic
- Menu navigation LEDs for Data, Setup, Service, Settings
- Main Menu and Help Buttons for quick navigation to home screen and built-in help functions
- Scroll, Value Adjustment Select and Save Buttons
- Setup menu insures proper installation and simplified setup of the rooftop unit
- Profile setup copies key settings between units with the same configuration to reduce setup time
- USB port allows a technician to download and transfer unit information to help verify service was performed
- USB software updates on the Prodigy Control System enhance functionality without the need to change components
- Unit Controller Software
- Unit self-test verifies individual critical component and system performance
- Economizer test function assures economizer is operating correctly
- Time Clock with Run-Time Information

Built-In Functions Include:

- Adjustable Blower On/Off Delay
- Built-in Control Parameter Defaults
- Compressor Time-Off Delay
- DDC Compatible
- Dirty Filter Switch Input
- Discharge Air Temperature Control
- Display/Sensor Readout
- Economizer Control Options (See Economizer / Exhaust Air / Outdoor Air sections)
- Fresh Air Tempering
- Over 100 diagnostic and status messages in English
- Exhaust Fan Control Modes for fresh air damper position
- Permanent Diagnostic Code Storage
- Field Adjustable Control Parameters (Over 200 settings)
- Indoor Air Quality Input (Demand Control Ventilation)
- Low Ambient Controls for cooling operation down to 0°F
- Gas Valve Time Delay Between First and Second Stage

- Minimum Compressor Run Time
- Network Capable (Can be daisy chained to other units or controls)
- Night Setback Mode
- Return Air Temperature Limit Control
- Safety Switch Input allows Controller to respond to a external safety switch trip
- Service Relay Output
- Smoke Alarm Mode has four choices (unit off, positive pressure, negative pressure, purge)
- Up to 2 heat/2 cool (standard Prodigy unit controller thermostat input)
- Up to 3 cool with additional relay
- Up to 4 cool with room sensor or network operation
- "Strike Three" Protection
- Gas Reheat Control allows simultaneous heating and cooling operation for humidity control of process air applications such as supermarkets
- On Demand Dehumidification monitors and controls condenser hot gas reheat operation with Humiditrol® dehumidification option
- Thermostat Bounce Delay
- Warm Up Mode Delay
- LED Indicators
- PC Interface connects the Prodigy 2.0 unit controller to a PC with the Lennox Unit Controller Software
- Room Sensor Operation controls temperature

NOTE - Prodigy Control System features shown vary with the type of rooftop unit the control is installed in.

NOTE - See separate Prodigy Control System Product Specifications Bulletin for additional information.

CONTROL SYSTEM

PRODIGY® CONTROL SYSTEM (continued)

Controls Options

Factory or Field Installed

Blower Proving Switch

- Monitors blower operation, shuts down unit if blower fails

Dirty Filter Switch

- Senses static pressure increase indicating dirty filter condition

Fresh Air Tempering

- Used in applications with high outside air requirements
- Controller energizes the first stage heat as needed to maintain a minimum supply air temperature for comfort, regardless of the thermostat demand
- When ordered as a factory option, sensor ships with the unit for field installation

Smoke Detector

- Photoelectric type
- Installed in supply air section, return air section or both sections
- Available with power board and single sensor (supply or return) or power board and two sensors (supply and return)
- Power board located in unit control compartment

Interoperability via BACnet® or LonTalk® Protocols

- Communication compatible with third-party automation systems that support the BACnet Application Specific Controller device profile, LonMark® Space Comfort Controller functional profile, or LonMark Discharge Air Controller functional profile

Commercial Control Systems

L Connection® Network Control System

- Complete building automation control system for single or multi-zone applications
- Options include local interface, software for local or remote communication, and hardware for networking other control functions
- See L Connection Network Control System Product Specifications Bulletin for details

After-Market DDC

- Novar® Unit Controller and options

Thermostats

- Control system and thermostat options
- After-Market unit controller options

Field Installed

General Purpose Control Kit

- Plug-in control provides additional analog and digital inputs/outputs for field installed options

OPTIONS / ACCESSORIES

ECONOMIZER

- Economizer operation is set and controlled by the Prodigy 2.0 unit controller
- Simple plug-in connections from economizer to unit controller for easy installation
- All Emergence rooftop units are equipped with factory installed CEC Title 24 approved sensors for outside, return and discharge air temperature monitoring

NOTE - Optional sensors may be used instead of unit sensors to determine whether outdoor air is suitable for free cooling. See Options/Accessories table.

Factory or Field Installed

12 High Performance Economizer

- Approved for California Title 24 building standards
- Low leakage dampers are Air Movement and Control Association International (AMCA) Class 1A Certified - Maximum 3 CFM per sq. ft. leakage at 1 in. w.g.
- ASHRAE 90.1-2010 compliant
- Outdoor Air Hood with mist elimination is included when economizer is factory installed and is furnished with economizer when ordered for field installation
- Gear-driven action
- High torque 24-volt fully-modulating spring return damper motor
- Return air and outdoor air dampers
- Plug-in connections to unit
- Stainless steel bearings
- Enhanced neoprene blade edge seals
- Flexible stainless steel jamb seals

NOTE - High Performance Economizers are not approved for use with enthalpy controls in Title 24 applications.

NOTE - The Free Cooling setpoint for Title 24 applications must be set based on the Climate Zone where the system is installed. See Section 140.4 "Prescriptive Requirements for Space Conditioning Systems" of the California Energy Commission's 2013 Building Energy Efficiency Standards.

NOTE - Refer to Installation Instructions for complete setup information.

OPTIONS / ACCESSORIES

ECONOMIZER (continued)

Differential Sensible Control

- Factory setting
- Uses outdoor air and return air sensors that are furnished with the unit
- The Prodigy® 2.0 unit controller compares outdoor air temperature with return air
- When the outdoor air is below the configured setpoint and cooler than return air, the controller activates the economizer

NOTE - Differential Sensible Control can be configured in the field to provide Offset Differential Sensible Control or Single Sensible Control.

NOTE - In Offset Differential Sensible Control mode, the economizer is enabled if the temperature differential (offset) between outdoor air and return air reaches the configured setpoint. In Single Sensible Control mode, the economizer is enabled when outdoor air temperature falls below the configured setpoint.

Global Control

- The unit controller communicates with a DDC system with one global sensor (enthalpy or sensible)
- Determines whether outside air is suitable for free cooling on all units connected to the control system
- Sensor must be field provided

NOTE - Global control with enthalpy is not approved for Title 24 applications.

Factory or Field Installed

Single Enthalpy Temperature Control (Not for Title 24)

- Outdoor air enthalpy sensor enables Economizer if the outdoor enthalpy is less than the setpoint of the control

Differential Enthalpy Control (Not for Title 24)

- Order two Single Enthalpy Controls
- One is field installed in the return air section
- One is installed in the outdoor air section
- Allows the economizer control to select between outdoor air or return air, whichever has lower enthalpy

Field Installed

Outdoor Air CFM Control

- Maintains constant outdoor air volume levels on the supply air fan and varying unit airflows
- Velocity sensor located in the rooftop unit outdoor air section, the Prodigy® 2.0 unit controller changes the economizer position to help minimize the effect of supply fan speed changes on outdoor air volume levels
- Setpoint for outdoor air volume is established by field testing

NOTE - Not available with Demand Control Ventilation (CO₂ Sensor) or Building Pressure Control.

Building Pressure Control

- Maintains constant building pressure level
- Includes a static pressure transducer and outdoor static pressure assembly
- Using differential pressure information between the outdoor air and the building air, the Prodigy® 2.0 unit controller changes the economizer position to help maintain a constant building pressure

NOTE - Not available with Demand Control Ventilation (CO₂ Sensor) or Outdoor Air CFM Control.

EXHAUST

Factory or Field Installed

13 Downflow Barometric Relief Dampers

- Allow relief of excess air
- Aluminum blade dampers prevent blow back and outdoor air infiltration during off cycle
- Exhaust hood is factory installed when dampers are factory installed with economizer
- Exhaust hood is furnished with dampers when ordered for field installation
- Bird screen furnished

14 Standard Static Power Exhaust Fans

- Installs internal to unit for downflow applications only with economizer option
- Provides exhaust air pressure relief
- Interlocked to run when return air dampers are closed and supply air blower is operating
- Fans run based on air damper position (adjustable)
- Three 1/3 hp motors
- 20 in. diameter propeller-type fans
- Five blades
- Total power input of 1125 Watts
- Total air volume of 12,800 cfm at 0 in. w.g.
- Motor is inherently protected
- Totally enclosed
- Steel cabinet and hood painted to match unit

NOTE - Requires optional Downflow Economizer Barometric Relief Dampers. See Standard Static Power Exhaust Blower Tables.

OPTIONS / ACCESSORIES

EXHAUST (continued)

Factory or Field Installed

Horizontal Barometric Relief Dampers

- For use when unit is configured for horizontal applications requiring an economizer
- Allows relief of excess air
- Aluminum blade dampers prevent blow back and outdoor air infiltration during off cycle
- Field installed in return air duct
- Bird screen and hood furnished

NOTE - Horizontal Economizer Conversion kit is available for field installation.

Field Installed

High Static Power Exhaust

- Constant volume high static power exhaust blowers
- Choice of 50% (two, 2 hp motors) or 100% (three, 2 hp motors)
- Centrifugal-type power exhaust blowers
- Overload and sub-fuse protected
- Ball bearings
- Forward curved blades
- Blower wheel is statically and dynamically balanced
- Adjustable pulleys for speed adjustments
- Controlled by damper position.

NOTE - VAV/MSAV units can be ordered with High Static Power Exhaust (with VFD) and an optional factory installed Manual Supply VFD Blower Bypass for the Power Exhaust VFD's (see page 5). High Static Power Exhaust (with VFD) features a solid-state analog pressure transducer control which senses differential pressure between conditioned space and outdoor air to regulate exhaust blower speed. See High Static Power Exhaust Blower Tables.

NOTE - High Static Power Exhaust is field installed but must be ordered at the same time as the rooftop unit so the unit can be factory configured for this option.

Power Exhaust Control Options

Damper Position Control

- For Standard or High Static Power Exhaust without VFD
- Prodigy® 2.0 unit controller controls the power exhaust based on economizer damper position

Differential Pressure Transducer

- For High Static Power Exhaust with VFD
- Prodigy® 2.0 unit controller controls the power exhaust system based on a 0-10VDC signal from a differential pressure transducer, which compares atmospheric pressure to conditioned space static pressure
- The transducer is factory installed in the power exhaust section

Field Installed

Pressure Switch

- For Standard or High Static Power Exhaust without VFD
- Prodigy® 2.0 unit controller controls the power exhaust system based on one or two pressure switch(es)

NOTE - Order one per unit with Standard or High Static Power Exhaust without VFD.

NOTE - Order two per unit with Standard Static Power Exhaust for MSAV or VAV models.

OUTDOOR AIR

Factory or Field Installed

Outdoor Air Damper - Downflow or Horizontal With Air Hood

- Linked mechanical dampers
- 0 to 25% (fixed) outdoor air adjustable
- Installs in unit
- Includes outdoor air hood
- Automatic model features fully modulating spring return damper motor with plug-in connection
- Manual model features parallel blade, gear-driven dampers with adjustable fixed position

NOTE - Minimum mixed air temperature in heating mode is 30°F. Maximum mixed air temperature in cooling mode is 90°F.

OPTIONS / ACCESSORIES

ROOF CURBS

- Nailer strip furnished (downflow only)
- Mates to unit
- US National Roofing Contractors Approved
- Shipped knocked down

Downflow

Hybrid Roof Curbs

- Interlocking tabs fasten corners together
- No tools required
- Can also be fastened together with furnished hardware
- Available in 14, 18, and 24 inch heights

Horizontal

- Converts unit from downflow to horizontal (side) air flow
- Return air is on unit
- Supply air is on curb
- Available in 37 inch and 41 inch heights.
- See dimension drawings

NOTE - Requires Horizontal Return Air Panel Kit.

NOTE - Optional Insulation Kit is available to help prevent sweating.

CEILING DIFFUSERS

Field Installed

Ceiling Diffusers

(Flush or Step-Down)

- White powder coat finish on diffuser face and grilles
- Insulated UL listed duct liner
- Diffuser box has collars for duct connection
- Step-down diffusers have double deflection blades
- Flush diffusers have fixed blades
- Provisions for suspending
- Internally sealed to prevent recirculation
- Removable return air grille
- Adapts to T-bar ceiling grids or plaster ceilings

Transitions (Supply and Return)

- Used with diffusers
- Installs in roof curb
- Galvanized steel construction
- Flanges furnished for duct connection to diffusers
- Fully insulated

15 OVERVIEW

NOTE - Available for 300H and 360H models only with MSAV option and without VFD Bypass Option.

- Factory installed option designed to control humidity
- Provides dehumidification on demand using ASHRAE 90.1 recommended method for comfort conditioning humidity control
- Unit comes equipped with one row reheat coil, solenoid valve and humidity controller
- In addition to a thermostat or room sensor used for conventional operation, a humidity sensor is required and must be located in the occupied space
- Remote Mounted Humidity Sensor Kit is required for field installation
- Humidity sensor provides input to the Unit Controller which is used to control activation of the dehumidification operation
- Reheat controls are located in the compressor control section of the unit for easy access

BENEFITS

- Improves indoor air quality
- Helps prevent damage due to high humidity levels
- Improves comfort levels by reducing space humidity levels

OPERATION

No Dehumidification Demand

- The unit will operate conventionally whenever there is a demand for cooling or heating and no dehumidification demand
- Free cooling is only permitted when there is no demand for dehumidification

Dehumidification Demand Only

- The Unit Controller is factory set at 60% relative humidity setpoint and can be adjusted at the Unit Controller or with optional Unit Controller Software
- For L Connection® Network Control Panel (NCP) applications, the humidity setpoint can be adjusted at the NCP
- Reheat operation will initiate on a dehumidification demand and does not require a cooling demand
- The unit will operate in the dehumidification mode until the relative humidity of the conditioned space is below the setpoint
- The reheat coil is sized to provide 68°F to 75°F supply air during reheat operation
- This reduces sensible cooling capacity and extends compressor run time to control humidity when the cooling load is low
- A solenoid valve diverts hot gas from the compressor to the reheat coil
- The cooled and dehumidified air from the evaporator is reheated as it passes through the reheat coil
- The de-superheated and partially condensed refrigerant continues to the outdoor condenser coil where condensing is completed
- The unit will continue to operate in this mode until the dehumidification demand is satisfied

NOTE - See Sequence of Operation for additional information.

Dehumidification and Cooling Demand (Thermostat/ Room Sensor Application)

- If both a dehumidification and a full cooling demand occur, the system will operate in cooling until the cooling demand is satisfied
- Then the system will energize the dehumidification mode

Options/Accessories

Humidity Sensor Kit

- Remote Mounted Humidity sensor required with factory installed Humiditrol® Dehumidification Option or Supermarket reheat field selectable option

HUMIDITROL® DEHUMIDIFICATION SYSTEM OPTION

REFRIGERANT SCHEMATIC

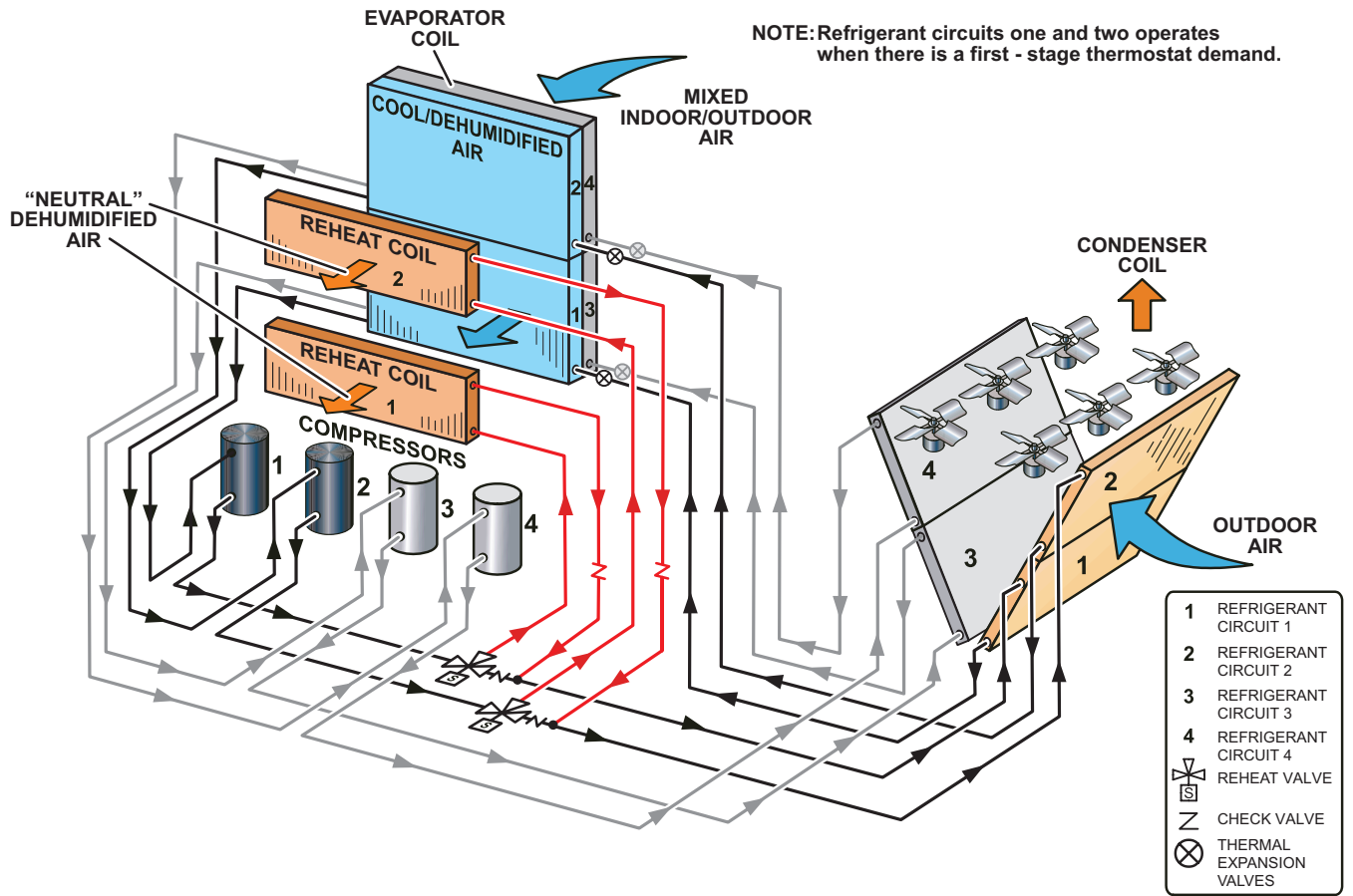

OPTIONAL CONVENTIONAL TEMPERATURE CONTROL SYSTEMS

ComfortSense® 8500 Commercial 7-Day Programmable Thermostat

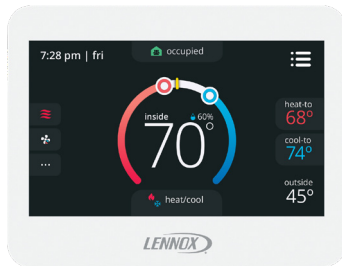

- Fully Communicating Sensor
- Full Color Touchscreen Interface
- Variable Speed System Control (On Compatible Units)
- Up To 4 Heat / 4 Cool
- Built-In Sensors For Temperature, Humidity And Optional CO₂
- Remote Sensor Options For Occupancy, Temperature
- BACnet Capable Options
- 5-2 or 7-Day Scheduling
- Smooth Setback Recovery
- Heat/Cool Auto-Changeover
- Four-Wire Installation
- FDD, ASHRAE, IECC Compliant

ComfortSense® 7500 Commercial 7-Day Programmable Thermostat



- Premium Universal Thermostat
- Full Color Touchscreen Interface
- Up To 4 Heat / 4 Cool
- Built-In Sensors For Temperature and Humidity
- Remote Sensors Options For Temperature, Discharge Air, Outdoor Air
- 5-2 or 7-Day Scheduling
- Smooth Setback Recovery
- Heat/Cool Auto-Changeover
- FDD, ASHRAE, IECC Compliant

ComfortSense® 3000 Commercial 5-2 Day Programmable Thermostat

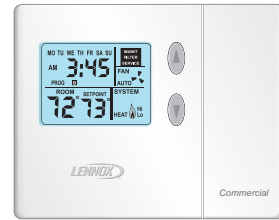

- Conventional Multi-Stage Thermostat
- Intuitive Display
- Push-Button Operation
- Up To 2 Heat / 2 Cool
- Built-In Temperature Sensor
- Remote Temperature Sensing
- Up to 5-2 Day Scheduling
- Smooth Setback Recovery
- Heat/Cool Auto-changeover

Wired Room Sensor (LCS-5030)



- Simple Push-Button Override
- Variable Speed System Control (On Compatible Units)
- Up To 4 Heat / 4 Cool
- Built-In Temperature and Humidity Sensors
- AA Battery / 24VAC Powered
- SBUS Wired Operation
- Automatic Sensor Averaging
- Locking Hex Screw

OPTIONAL CONVENTIONAL TEMPERATURE CONTROL SYSTEMS

Description	Catalog No.
ComfortSense® 8500 Commercial 7 Day Programmable Thermostat	
CS8500 7-Day Thermostat	No CO ₂ Sensing 17G75
	With CO ₂ Sensing 17G76
Sensors/Accessories	¹ Remote non-adjustable wall-mount 10k 47W37
	¹ Remote non-adjustable wall-mount 11k 94L61
Sysbus Network Cable (Yellow) for ComfortSense 8500 and LCS-5030 Wired Room Sensor	
Twisted pair 100% shielded communication cable, Red and Black	500 ft. box 27M19
22 AWG, yellow jacket, rated at 75°C, 300V, Plenum rated	1000 ft. box 94L63
Insulation - Low smoke PVC, NEC, CMP	2500 ft. roll 68M25
ComfortSense® 7500 Commercial 7-Day Programmable Thermostat	
CS7500 7-Day Thermostat	17G74
Sensors/Accessories	² Remote non-adjustable wall-mount 20k 47W36
	² Remote non-adjustable wall-mount 10k 47W37
	Remote non-adjustable discharge air (duct mount) 19L22
	Outdoor temperature sensor X2658
ComfortSense® 3000 Commercial 5-2 Day Programmable Thermostat	
CS3000 5-2 Day Thermostat	11Y05
Sensors/Accessories	Remote non-adjustable wall mount 10k averaging 47W37
	Thermostat wall mounting plate X2659
ComfortSense® Non-Programmable Thermostat	
CS3000 Non-Programmable Thermostat	51M32
Universal Thermostat Guard with Lock (clear)	
	Inside Dimensions (H x W) 5 7/8 x 8 3/8 in. 39P21
Wired Room Sensor	
LCS-5030 Wired Room Sensor	21L07

¹ Up to nine of the same type remote temperature sensors can be connected in parallel.

² Remote wall-mount sensors can be applied in any of the following combinations:
 One Sensor - (1) 47W36, Two Sensors - (2) 47W37, Three Sensors - (2) 47W36 and (1) 47W37
 Four Sensors - (4) 47W36, Five Sensors - (3) 47W36 and (2) 47W37

Objective: Outline the unit functions as a result of room thermostat or room sensor demands.

Given: When economizer is present, it will function as an integral part of the unit cooling system. When not present, unit will function as if economizer is present but outdoor ambient is high and sensed as not suitable.

UNIT OPERATION WITH 2-STAGE THERMOSTAT OR THIRD PARTY UNIT CONTROLLERS (2 HEAT / 2 COOL)
(THIS SECTION NOT APPLICABLE FOR DISCHARGE AIR TEMPERATURE CONTROL)

SUPPLY AIR BLOWER SPEED

Unit has one blower speed for all modes of operation.

COOLING MODE (2 Cool)

¹ Unit Features An Economizer And Outdoor Air Is Suitable

Y1 Demand:

All compressors are off, supply air blower is on; economizer modulates (minimum to maximum open position) to satisfy thermostat demand.

Y2 Demand:

All compressors are off, supply air blower is on, and economizer modulates (minimum to maximum open position) to maintain 55°F discharge air temperature.

NOTE - If economizer stays at maximum open for 3 minutes, compressors 1 and 2 are energized with the supply air blower on, providing maximum cooling capacity.

NOTE - The thermostat or third party unit controller has direct control over the rooftop unit's staging capability. While the unit controller typically has direct control over the economizer, it is possible for a thermostat or third party unit controller to directly control this functionality

¹ Outdoor air suitability is determined by the energy state of outdoor ambient (enthalpy or sensible) and its ability to achieve the desired free cooling effects. Outdoor air suitability can also be determined by a third party controller and provided to the RTU via a network connection.

Unit Does Not Feature An Economizer Or Outdoor Air Is Not Suitable

Y1 Demand:

The first two compressors operate and the supply air blower is activated. This is ~50% of the cooling capacity.

Y2 Demand:

All compressors operate and supply air blower is activated. This is 100% of the cooling capacity.

HEATING MODE (2 Heat)

NOTE - HEATING MODE IS THE SAME FOR ALL CONTROL OPTIONS.

W1 Demand:

1st stage electric heat is energized and the supply air blower operates at heating speed.

W2 Demand:

2nd stage electric heat is energized and the supply air blower operates at heating speed (45, 60, 90 or 120 kW electric heat option only).

UNIT OPERATION IN ROOM SENSOR MODE OR DISCHARGE AIR TEMPERATURE CONTROL (4 HEAT / 4 COOL)

SUPPLY AIR BLOWER SPEED

Unit has one blower speed for all modes of operation.

COOLING MODE (4 Cool)

- Room sensors (when connected to S-Bus) or Discharge air temperature (DAT) can be used to control unit staging.
- DAT default setpoint = 55°F. Unit will stage compressors as required to maintain the setpoint when provided with Y1 thermostat demand.
- Room sensor occupied default setpoint = 75°F. Unit will stage compressors as required to maintain the setpoint.
- Increasing compressor stages provides more cooling capacity while decreasing compressor stages provides less cooling capacity.

¹ Unit Features An Economizer And Outdoor Air Is Suitable

Cooling Stage 1:

All compressors are off, supply air blower is on; economizer modulates (minimum to maximum open position) to maintain setpoint.

Cooling Stage 2:

One compressor is activated; supply air blower is on; economizer modulates (minimum to maximum open position) to maintain setpoint.

Cooling Stage 3:

Two compressors are activated; supply air blower is on; economizer modulates (minimum to maximum open position) to maintain setpoint.

Cooling Stage 4:

All compressors are activated; supply air blower is on; economizer modulates (minimum to maximum open position) to maintain setpoint.

NOTE - The thermostat or third party unit controller has direct control over the rooftop unit's staging capability. While the unit controller typically has direct control over the economizer, it is possible for a thermostat or third party unit controller to directly control this functionality

¹ *Outdoor air suitability is determined by the energy state of outdoor ambient (enthalpy or sensible) and its ability to achieve the desired free cooling effects. Outdoor air suitability can also be determined by a third party controller and provided to the RTU via a network connection.*

Unit Does Not Feature An Economizer Or Outdoor Air Is Not Suitable

Cooling Stage 1:

The first compressor is activated; supply air blower is on. This is ~25% of the cooling capacity.

Cooling Stage 2:

The first and second compressors are activated; supply air blower is on. This is ~50% of the cooling capacity.

Cooling Stage 3:

The first three compressors are activated; supply air blower is on. This is ~75% of the cooling capacity.

Cooling Stage 4:

All compressors operate and supply air blower is activated. This is 100% of the cooling capacity.

HEATING MODE (4 Heat)

- Room sensors (when connected to S-Bus) or Discharge air temperature (DAT) can be used to control up to four stages of electric heat.
- DAT default setpoint = 110°F. Unit will stage heating as required to maintain the setpoint when provided with W1 demand.
- Room sensor occupied setpoint default = 70°F. Unit will stage heating as required to maintain the setpoint.
- Increasing heat stages provides more heating capacity while decreasing heat stages provides less heating capacity.
- Blower set to Heating Speed for all stages.

**UNIT OPERATION WITH 2-STAGE THERMOSTAT OR THIRD PARTY UNIT CONTROLLERS (2 HEAT / 2 COOL)
(THIS SECTION NOT APPLICABLE FOR DISCHARGE AIR TEMPERATURE CONTROL)****SUPPLY AIR BLOWER SPEED**

Unit has the following supply air blower speed settings:

- Ventilation Speed
- Low Cooling Speed
- High Cooling Speed
- Heating Speed
- Smoke Speed (Used only in smoke removal option - not discussed)

COOLING MODE (2 Cool)**¹ Unit Features An Economizer And Outdoor Air Is Suitable****Y1 Demand:**

All compressors are off, supply air blower is set to Low Cooling Speed; economizer modulates (minimum to maximum open position) to maintain 55°F discharge air temperature.

Y2 Demand:

All compressors are off, supply air blower is set to High Cooling Speed, and economizer modulates (minimum to maximum open position) to maintain 55°F discharge air temperature.

NOTE - If economizer stays at maximum open for 3 minutes, 1st stage compressors (compressor 1 and 2) are energized while supply air blower stays on high cooling speed providing maximum cooling capacity.

¹ Outdoor air suitability is determined by the energy state of outdoor ambient (enthalpy or sensible) and its ability to achieve the desired free cooling effects. Outdoor air suitability can also be determined by a third party controller and provided to the RTU via a network connection.

Unit Does Not Feature An Economizer Or Outdoor Air Is Not Suitable**Y1 Demand:**

The first two compressors operate and the supply air blower is activated. The blower is set to the Low Cooling Speed.

Y2 Demand:

All compressors operate and supply air blower is activated. The blower is set to the High Cooling Speed.

Dehumidification Mode

If a unit with Humiditrol® Dehumidification Option receives a call for dehumidification, economizer free cooling is locked out.

Call For Dehumidification, No Y1, Y2 Demand:

Compressors 1 and 2 operate, supply air blower operates at low cooling speed, and both reheat valves are energized.

Y1 Demand With A Call For Dehumidification:

All compressors operate, supply air blower operates at high cooling speed and both reheat valves are energized.

Y2 Demand With A Call For Dehumidification:

All compressors operate, supply air blower operates at high cooling speed, and the reheat valves are de-energized.

HEATING MODE (2 Heat)**W1 Demand:**

The first two stages of mechanical heat are activated; the blower is set to Heating Speed.

W2 Demand:

The third and fourth stages of mechanical heat are activated; the blower is set to the Heating Speed.

**UNIT OPERATION IN ROOM SENSOR MODE OR DISCHARGE AIR TEMPERATURE CONTROL
(4 HEAT / 4 COOL)****SUPPLY AIR BLOWER SPEED**

Unit has the following supply air blower speed settings:

- Ventilation speed
- Cooling Speed 1 (low)
- Cooling Speed 2 (medium-low)
- Cooling Speed 3 (medium-high)
- Cooling Speed 4 (high)
- Heating Speed
- Smoke Speed (Used only in smoke removal option - not discussed)

COOLING MODE (4 Cool)

- Room sensors (when connected to S-Bus) or Discharge air temperature (DAT) can be used to control unit staging.
- DAT default setpoint = 55°F. Unit will stage compressors as required to maintain the setpoint when provided with Y1 thermostat demand.
- Room sensor occupied default setpoint = 75°F. Unit will stage compressors as required to maintain the setpoint.
- Increasing compressor stages provides more cooling capacity while decreasing compressor stages provides less cooling capacity.

¹ Unit Features An Economizer And Outdoor Air Is Suitable**Cooling Stage 1:**

All compressors are off, supply air blower is on Cooling Speed 1 to minimize blower power consumption, economizer modulates (minimum to maximum open position) to maintain setpoint.

Cooling Stage 2:

All compressors are off, supply air blower is on Cooling Speed 4 to provide higher cooling capacity, and economizer modulates to maintain setpoint. If economizer stays at maximum open for 3 minutes, compressor 1 is energized while supply air blower stays on Cooling Speed 4. After compressor 1 is energized, the economizer stays at maximum open.

Cooling Stage 3:

Compressor 1 and 2 are energized while supply air blower is on Cooling speed 4 to provide even higher cooling capacity.

Cooling Stage 4:

All compressors are energized while supply air blower is on Cooling speed 4 to provide maximum cooling capacity. 1 Outdoor air suitability is determined by the energy state of outdoor ambient (enthalpy or sensible) and its ability to achieve the desired free cooling effects. Outdoor air suitability can also be determined by a third party controller and provided to the RTU via a network connection.

Unit Does Not Feature An Economizer Or Outdoor Air Is Not Suitable**Cooling Stage 1:**

Compressor 1 operates and supply air blower operates at Cooling Speed 1.

Cooling Stage 2:

Compressors 1 and 2 operate and supply air blower operates at Cooling Speed 2.

Cooling Stage 3:

Compressors 1, 2, and 3 operate and supply air blower operates at Cooling Speed 3.

Cooling Stage 4:

All compressors operate and supply air blower operates at Cooling Speed 4.

**UNIT OPERATION IN ROOM SENSOR MODE OR DISCHARGE AIR TEMPERATURE CONTROL
(4 HEAT / 4 COOL) (CONTINUED)****Dehumidification Mode**

If a unit with Humiditrol® Dehumidification Option receives a call for dehumidification, economizer free cooling is locked out.

Call For Dehumidification, No Y1, Y2, Y3, Y4 Demand:

Compressors 1 and 2 operate, supply air blower operates at medium-low cooling speed, and both reheat valves are energized.

Y1 Demand With A Call For Dehumidification:

Compressors 1, 2, and 3 operate, supply air blower operates at high cooling speed and both reheat valves are energized.

Y2 Demand With A Call For Dehumidification:

All compressors operate, supply air blower operates at high cooling speed and both reheat valves are energized.

Y3 Demand With A Call For Dehumidification:

All compressors operate, supply air blower operates at high cooling speed, and the reheat valve of compressor 1 is energized while the reheat valve of compressor 2 is de-energized.

Y4 Demand With A Call For Dehumidification:

All compressors operate, supply air blower operates at high cooling speed, and the reheat valves are de-energized.

HEATING MODE (4 Heat)

- Room sensors (when connected to S-Bus) or Discharge air temperature (DAT) can be used to control up to four stages of electric heat.
- DAT default setpoint = 110°F. Unit will stage heating as required to maintain the setpoint when provided with W1 demand.
- Room sensor occupied setpoint default = 70°F. Unit will stage heating as required to maintain the setpoint.
- Increasing heat stages provides more heating capacity while decreasing heat stages provides less heating capacity.
- Blower set to Heating Speed for all stages.

UNITS IN ZONING APPLICATIONS OPERATING WITH DISCHARGE AIR CONTROL (4 HEAT / 4 COOL)**SUPPLY AIR BLOWER SPEED**

Unit has the following supply air blower speed settings:

- Ventilation Speed
- Cooling Speed - Fully modular based on supply duct static pressure
- Heating Speed
- Smoke Speed (Used only in smoke removal option - not discussed)

COOLING MODE (4 Cool)

- Discharge air temperature (DAT) can be used to control unit staging.
- DAT default setpoint = 55°F. Unit will stage compressors as required to maintain the setpoint when provided with Y1 thermostat demand.
- Increasing compressor stages provides more cooling capacity while decreasing compressor stages provides less cooling capacity.

¹ Unit Features An Economizer And Outdoor Air Is Suitable**Cooling Stage 1:**

All compressors are off, supply air blower operates to maintain duct static pressure, economizer modulates (minimum to maximum open position) to maintain 55°F supply air temperature (default unit controller setting).

Cooling Stage 2:

All compressors are off, supply air blower operates to maintain duct static pressure, and economizer modulates to maintain 55°F supply air temperature. If economizer stays at maximum open for 3 minutes, compressor 1 is energized while supply air blower operates to maintain duct static pressure. After compressor 1 is energized, the economizer stays at maximum open.

Cooling Stage 3:

Compressor 1 and 2 are energized while supply air blower operates to maintain duct static pressure.

Cooling Stage 4:

All compressors are energized while supply air blower operates to maintain duct static pressure.

¹ Outdoor air suitability is determined by the energy state of outdoor ambient (enthalpy or sensible) and its ability to achieve the desired free cooling effects. Outdoor air suitability can also be determined by a third party controller and provided to the RTU via a network connection.

Unit Does Not Feature An Economizer Or Outdoor Air Is Not Suitable**Cooling Stage 1:**

Compressor 1 operates and supply air blower operates to maintain duct static pressure.

Cooling Stage 2:

Compressors 1 and 2 operate and supply air blower operates to maintain duct static pressure.

Cooling Stage 3:

Compressors 1, 2, and 3 operate and supply air blower operates to maintain duct static pressure.

Cooling Stage 4:

All compressors operate and supply air blower operates to maintain duct static pressure.

UNIT IN ZONING APPLICATIONS OPERATING WITH DISCHARGE AIR CONTROL (4 HEAT / 4 COOL) (CONTINUED)**HEATING MODE (4 Heat)**

- Room sensors (when connected to S-Bus) or Discharge air temperature (DAT) can be used to control up to four stages of electric heat.
- DAT default setpoint = 110°F. Unit will stage heating as required to maintain the setpoint when provided with W1 demand.
- Room sensor occupied setpoint default = 70°F. Unit will stage heating as required to maintain the setpoint.
- Increasing heat stages provides more heating capacity while decreasing heat stages provides less heating capacity.
- Blower set to Heating Speed for all stages.

Modulating Outdoor Air Damper

The minimum damper position for “occupied low blower” and “occupied high blower” is adjusted during unit setup to provide minimum fresh air requirements per ASHRAE 62.1 at the corresponding supply air blower speeds.

- When supply air blower is off or the unit is in unoccupied mode, the outdoor air damper is closed.
- When unit is in occupied mode and supply air blower is operating at a speed below the “midpoint” blower speed, the outdoor air damper is at minimum “low blower” position.
- When unit is in occupied mode and supply air blower is operating at a speed equal to or above the “midpoint” blower speed, the outdoor air damper is at minimum “high blower” position.

NOTE - The “midpoint” blower speed is an average of the minimum and maximum blower speed ((minimum speed + maximum speed) divided by 2).

OPTIONS / ACCESSORIES

Item Description	Catalog Number	Unit Model No.			
		242	300	360	
COOLING SYSTEM					
Condensate Drain Trap	PVC	22H54	OX	OX	OX
	Copper	76W27	OX	OX	OX
Corrosion Protection	Factory		O	O	O
Drain Pan Overflow Switch		21Z07	OX	OX	OX
Efficiency	High	Factory	O	O	O
Refrigerant Type	R-410A	Factory	O	O	O
Plastic Condensate Drain Pan		Factory	O	O	O
Stainless Steel Condensate Drain Pan		83W42	OX	OX	OX
BLOWER - SUPPLY AIR					
Motors	Belt Drive (standard efficiency) - 5 hp	Factory	O	O	O
	Belt Drive (standard efficiency) - 7.5 hp	Factory	O	O	O
	Belt Drive (standard efficiency) - 10 hp	Factory	O	O	O
	Supply VFD Blower Bypass (VAV/MSAV units w/VFD only)	Factory	O	O	O
Drive Kits See Blower Data Tables for usage and selection	Kit #1 740-895 rpm	Factory	O	O	O
	Kit #2 870-1045 rpm	Factory	O	O	O
	Kit #3 715-880 rpm	Factory	O	O	O
	Kit #4 770-965 rpm	Factory	O	O	O
	Kit #5 660-810 rpm	Factory	O	O	O
	Kit #6 770-965 rpm	Factory	O	O	O
	Kit #7 570-720 rpm	Factory	O	O	O
	Kit #8 480-630 rpm	Factory	O	O	O
	Kit #9 410-535 rpm	Factory	O	O	O
	Blower Belt Auto-Tensioner	Factory	O	O	O
CABINET					
Combination Coil/Hail Guards		13T16	X	X	X
Grille Guards		86K30	X	X	X
Horizontal Return Air Panel Kit		38K48	X	X	X
CONTROLS					
Blower Proving Switch		21Z10	OX	OX	OX
Commercial Controls	CPC Einstein Integration	Factory	O	O	O
	Prodigy® Control System - BACnet® Module	59W51	OX	OX	OX
	Prodigy® Control System - LonTalk® Module	54W27	OX	OX	OX
	Novar® LSE	Factory	O	O	O
	L Connection® Building Automation System	- - -	OX	OX	OX
Dirty Filter Switch		53W68	OX	OX	OX
Discharge Air Temperature Sensor		Factory	O	O	O
Fresh Air Tempering		21Z08	OX	OX	OX
General Purpose Control Kit		13J78	X	X	X
Smoke Detector - Supply or Return (Power board and one sensor)		83W40	OX	OX	OX
Smoke Detector - Supply and Return (Power board and two sensors)		83W41	OX	OX	OX
Supply Static Limit Switch		79M80	X	X	X
Supply Static Limit Switch - Mounting Kit		79M81	X	X	X

NOTE - Catalog numbers shown are for ordering field installed accessories.

OX - Configure To Order (Factory Installed) or Field Installed

O = Configure To Order (Factory Installed)

X = Field Installed

OPTIONS / ACCESSORIES

Item Description	Catalog Number	Unit Model No.			
		242	300	360	
INDOOR AIR QUALITY					
Air Filters					
Healthy Climate® High Efficiency Air Filters 20 x 20 x 2 - order 12 per unit	MERV 8	54W21	OX	OX	OX
	MERV 13	52W39	OX	OX	OX
Replaceable Media Filter with Metal Mesh Frame (includes Non-Pleated Filter Media) 20 x 20 x 2- order 12 per unit		44N60	X	X	X
Indoor Air Quality (CO₂) Sensors					
Sensor - Wall-mount, off-white plastic cover with LCD display		77N39	X	X	X
Sensor - Wall-mount, off-white plastic cover, no display		87N53	X	X	X
Sensor - Black plastic case with LCD display, rated for plenum mounting		87N52	X	X	X
Sensor - Wall-mount, black plastic case, no display, rated for plenum mounting		87N54	X	X	X
CO ₂ Sensor Duct Mounting Kit - for downflow applications		85L43	X	X	X
Aspiration Box - for duct mounting non-plenum rated CO ₂ sensors (87N53 or 77N39)		90N43	X	X	X
ELECTRICAL					
Voltage 60 hz	208/230V - 3 phase	Factory	O	O	O
	460V - 3 phase	Factory	O	O	O
	575V - 3 phase	Factory	O	O	O
HACR Circuit Breakers		Factory	O	O	O
Disconnect Switch - See Electrical Accessories Tables on page 49 for selection	80 amp	54W85	OX	OX	OX
	150 amp	54W86	OX	OX	OX
	250 amp	54W87	OX	OX	OX
GFI Service Outlets	15 amp non-powered, field-wired (208/230V, 460V)	74M70	OX	OX	OX
	15 amp factory-wired and powered (208/230V, 460V, 575V)	Factory	O	O	O
	20 amp non-powered, field-wired (575V only)	67E01	OX	OX	OX
Weatherproof Cover for GFI		10C89	X	X	X
Phase/Voltage Detection		Factory	O	O	O
ELECTRIC HEAT					
30 kW	208/230V-3ph	53W92	OX	OX	OX
	460V-3ph	53W94	OX	OX	OX
	575V-3ph	53W95	OX	OX	OX
45 kW	208/230V-3ph	54W00	OX	OX	OX
	460V-3ph	54W02	OX	OX	OX
	575V-3ph	54W03	OX	OX	OX
60 kW	208/230V-3ph	54W08	OX	OX	OX
	460V-3ph	54W10	OX	OX	OX
	575V-3ph	54W11	OX	OX	OX
90 kW	208/230V-3ph	54W12	OX	OX	OX
	460V-3ph	54W14	OX	OX	OX
	575V-3ph	54W15	OX	OX	OX
120 kW	208/230V-3ph	73W98	OX	OX	OX
	460V-3ph	73W99	OX	OX	OX
	575V-3ph	74W00	OX	OX	OX
SCR (Silicon Controlled Rectifier) Electric Heat Control NOTE - The SCR option is not available with 60 kW, 90 kW (208/230V) and 120 kW (208/230V, 460V, 575V) electric heat models.		Factory	O	O	O
Thermostat (required)		Y9682	X	X	X
Duct Sensor (required)		Y9683	X	X	X
¹ HUMIDITROL® CONDENSER REHEAT OPTION					
Humiditrol® Dehumidification Option		Factory		O	O
Humidity Sensor Kit, Remote mounted (required)	-1	17M50		X	X

¹ Available for 300H and 360H models only with MSAV option and without VFD Bypass Option.

NOTE - Catalog numbers shown are for ordering field installed accessories.

OX - Configure To Order (Factory Installed) or Field Installed

O = Configure To Order (Factory Installed)

X = Field Installed

OPTIONS / ACCESSORIES

Item Description	Catalog Number	Unit Model No.			
		242	300	360	
ECONOMIZER					
High Performance Economizer (Approved for California Title 24 Building Standards / AMCA Class 1A Certified)					
High Performance Economizer Downflow or Horizontal Applications - Includes Outdoor Air Hood. Order Downflow or Horizontal Barometric Relief Dampers separately.	18X87	OX	OX	OX	
Economizer Controls					
Differential Enthalpy (Not for Title 24)	Order 2 21Z09	OX	OX	OX	
Sensible Control	Sensor is Furnished Factory	O	O	O	
Single Enthalpy (Not for Title 24)	21Z09	OX	OX	OX	
Global, Enthalpy	Sensor Field Provided Factory	O	O	O	
Building Pressure Control	13J77	X	X	X	
Differential Sensible	Sensor is Furnished Factory	O	O	O	
Outdoor Air CFM Control	13J76	OX	OX	OX	
Barometric Relief Dampers With Exhaust Hood					
Downflow Barometric Relief Dampers	76W17	OX	OX	OX	
Horizontal Barometric Relief Dampers	33K78	OX	OX	OX	
OUTDOOR AIR					
Outdoor Air Dampers With Outdoor Air Hood					
Motorized	18X89	OX	OX	OX	
Manual	18X88	OX	OX	OX	
POWER EXHAUST					
Standard Static	208/230V	74W21	OX	OX	OX
	460V	74W22	OX	OX	OX
	575V	74W23	OX	OX	OX
High Static - 50%	208/230V - Drive Kit #1 (405-533 rpm)	83M83	X	X	X
	208/230V - Drive Kit #2 (531-731 rpm)	84M34	X	X	X
	208/230V - Drive Kit #3 (731-932 rpm)	84M35	X	X	X
	460V - Drive Kit #1 (405-533 rpm)	83M84	X	X	X
	460V - Drive Kit #2 (531-731 rpm)	84M36	X	X	X
	460V - Drive Kit #3 (731-932 rpm)	84M37	X	X	X
	575V - Drive Kit #1 (405-533 rpm)	83M85	X	X	X
	575V - Drive Kit #2 (531-731 rpm)	84M38	X	X	X
	575V - Drive Kit #3 (731-932 rpm)	84M39	X	X	X
High Static - 100%	208/230V - Drive Kit #1 (406-533 rpm)	83M86	X	X	X
	208/230V - Drive Kit #2 (531-731 rpm)	84M40	X	X	X
	208/230V - Drive Kit #3 (731-932 rpm)	84M41	X	X	X
	460V - Drive Kit #1 (406-533 rpm)	83M87	X	X	X
	460V - Drive Kit #2 (531-731 rpm)	84M42	X	X	X
	460V - Drive Kit #3 (731-932 rpm)	84M43	X	X	X
	575V - Drive Kit #1 (406-533 rpm)	83M88	X	X	X
	575V - Drive Kit #2 (531-731 rpm)	84M44	X	X	X
	575V - Drive Kit #3 (731-932 rpm)	84M45	X	X	X
100% with VFD	208/230V	83M89	X	X	X
	460V	83M90	X	X	X
	575V	83M91	X	X	X
100% with VFD and Bypass	208/230V	83M92	X	X	X
	460V	83M93	X	X	X
	575V	83M94	X	X	X
Power Exhaust Control					
¹ Pressure Switch	79M79	X	X	X	

¹ Order one per unit with Standard or High Static Power Exhaust without VFD. Order two per unit with standard static power exhaust for MSAV® or VAV models.

NOTE - Catalog numbers shown are for ordering field installed accessories.

OX - Configure To Order (Factory Installed) or Field Installed

O = Configure To Order (Factory Installed)

X = Field Installed

OPTIONS / ACCESSORIES

Item Description	Catalog Number	Unit Model No.			
		242	300	360	
ROOF CURBS					
Hybrid Roof Curbs, Downflow					
14 in. height	11F62	X	X	X	
18 in. height	11F63	X	X	X	
24 in. height	11F64	X	X	X	
Standard Roof Curbs, Horizontal - Requires Horizontal Return Air Panel Kit					
30 in. height - slab applications	11T90	X	X	X	
41 in. height - rooftop applications	11T97	X	X	X	
Horizontal Return Air Panel Kit					
Required for Horizontal Applications with Roof Curb	38K48	X	X	X	
Insulation Kit For Standard Horizontal Curbs					
For 30 in. Curb	73K33	X	X	X	
For 41 in. Curb	73K35	X	X	X	
CEILING DIFFUSERS					
Step-Down - Order one	LARTD30/36S	45K74	X	X	X
Flush - Order one	LAFD30/36S	45K75	X	X	X
Transitions (Supply and Return) - Order one	LASRT30/36	33K80	X	X	X

NOTE - Catalog numbers shown are for ordering field installed accessories.

OX - Configure To Order (Factory Installed) or Field Installed

O = Configure To Order (Factory Installed)

X = Field Installed

SPECIFICATIONS

General Data		Nominal Tonnage	20 Ton	25 Ton	25 Ton	25 Ton
Model Number			LCH242H4V	LCH300H4B	LCH300H4V	LCH300H4M
Efficiency Type			High	High	High	High
Blower Type			VAV (Variable Air Volume)	CAV (Constant Air Volume)	VAV (Variable Air Volume)	MSAV® (Multi-Stage Air Volume)
Cooling Performance	Gross Cooling Capacity - Btuh		244,000	310,000	310,000	310,000
	Net Cooling Capacity - Btuh		¹ 238,000	² 300,000	² 300,000	² 300,000
	AHRI Rated Air Flow - cfm		6800	8100	8100	8100
	Total Unit Power - kW		19	25.4	25.8	25.8
	EER (Btuh/Watt)		¹ 12.5	² 11.8	² 11.6	² 11.6
	IEER (Btuh/Watt)		¹ 15.5	² 12.5	² 14.3	² 14.4
Refrigerant Charge	Refrigerant Type		R-410A	R-410A	R-410A	R-410A
	Circuit 1		8 lbs. 0 oz.	9 lbs. 4 oz.	8 lbs. 0 oz.	8 lbs. 0 oz.
	Circuit 2		8 lbs. 0 oz.	9 lbs. 0 oz.	8 lbs. 0 oz.	8 lbs. 0 oz.
	Circuit 3		8 lbs. 8 oz.	8 lbs. 12 oz.	8 lbs. 0 oz.	8 lbs. 0 oz.
	Circuit 4		8 lbs. 8 oz.	8 lbs. 8 oz.	8 lbs. 8 oz.	8 lbs. 8 oz.
Electric Heat Available - See page 39			30-45-60-90-120 kW			
Compressor Type (number)			Scroll (4)	Scroll (4)	Scroll (4)	Scroll (4)
Outdoor Coils	Net face area (total) - sq. ft.		68.3	68.3	68.3	68.3
	Number of rows		1	1	1	1
	Fins per inch		23	23	23	23
Outdoor Coil Fans	Motor - (No.) horsepower		(6) 1/3	(6) 1/3	(6) 1/3	(6) 1/3
	Motor rpm		1075	1075	1075	1075
	Total Motor watts		2500	2500	2500	2500
	Diameter - (No.) in.		(6) 24	(6) 24	(6) 24	(6) 24
	Number of blades		3	3	3	3
	Total Air volume - cfm		21,500	21,500	21,500	21,500
Indoor Coils	Net face area (total) - sq. ft.		31.40	31.40	31.40	31.40
	Tube diameter - in.		3/8	3/8	3/8	3/8
	Number of rows		4	4	4	4
	Fins per inch		14	14	14	14
	Drain connection - No. and size		(1) 1 in. NPT	(1) 1 in. NPT	(1) 1 in. NPT	(1) 1 in. NPT
	Expansion device type		Balance port TXV, removable head			
³ Indoor Blower and Kit Selection	Nominal motor output		5 hp, 7.5 hp, 10 hp			
	Maximum usable motor output (US Only)		5.75 hp, 8.63 hp, 11.5 hp			
	Motor - Kit kit number		5 hp Kit 5 660-810 rpm Kit 6 770-965 rpm Kit 7 570-720 rpm Kit 8 480-630 rpm Kit 9 410-535 rpm 7.5 hp Kit 3 715-880 rpm Kit 4 770-965 rpm 10 hp Kit 1 740-895 rpm Kit 2 870-1045 rpm			
	Blower wheel nom. D x W - in.		(2) 18 x 15	(2) 18 x 15	(2) 18 x 15	(2) 18 x 15
	Filters	Type of filter		Fiberglass, disposable		
Number and size - in.			(12) 20 x 20 x 2			
Electrical characteristics			208/230V, 460V or 575V - 60 hertz - 3 phase			

NOTE - Net capacity includes evaporator blower motor heat deduction. Gross capacity does not include evaporator blower motor heat deduction.

¹ AHRI Certified to AHRI Standard 340/360; 95°F outdoor air temperature and 80°F db/67°F wb entering evaporator air; minimum external duct static pressure.

² Tested at conditions included in with AHRI Standard 340/360.

³ Using total air volume and system static pressure requirements determine from blower performance tables rpm and motor output required. Maximum usable output of motors furnished are shown. In Canada, nominal motor output is also maximum usable motor output. If motors of comparable output are used, be sure to keep within the service factor limitations outlined on the motor nameplate.

SPECIFICATIONS

General Data		Nominal Tonnage	30 Ton	30 Ton	30 Ton
		Model Number	LCH360H4B	LCH360H4V	LCH360H4M
		Efficiency Type	High	High	High
		Blower Type	CAV (Constant Air Volume)	VAV (Variable Air Volume)	MSAV® (Multi-Stage Air Volume)
Cooling Performance	Gross Cooling Capacity - Btuh		370,000	370,000	370,000
	¹ Net Cooling Capacity - Btuh		354,000	350,000	350,000
	AHRI Rated Air Flow - cfm		9600	8600	8600
	Total Unit Power - kW		32.8	32.4	32.4
	¹ EER (Btuh/Watt)		10.8	10.8	10.8
	¹ IEER (Btuh/Watt)		11.6	13.5	14.0
Refrigerant Charge	Refrigerant Type		R-410A	R-410A	R-410A
	Circuit 1		9 lbs. 0 oz.	8 lbs. 0 oz.	8 lbs. 0 oz.
	Circuit 2		8 lbs. 0 oz.	8 lbs. 0 oz.	8 lbs. 0 oz.
	Circuit 3		9 lbs. 0 oz.	8 lbs. 0 oz.	8 lbs. 0 oz.
	Circuit 4		7 lbs. 8 oz.	8 lbs. 0 oz.	8 lbs. 0 oz.
Electric Heat Available - See page 39			30-45-60-90-120 kW		
Compressor Type (number)			Scroll (4)		
Outdoor Coils	Net face area (total) - sq. ft.		68.3	68.3	68.3
	Number of rows		1	1	1
	Fins per inch		23	23	23
Outdoor Coil Fans	Motor - (No.) horsepower		(6) 1/3	(6) 1/3	(6) 1/3
	Motor rpm		1075	1075	1075
	Total Motor watts		2500	2500	2500
	Diameter - (No.) in.		(6) 24	(6) 24	(6) 24
	Number of blades		3	3	3
	Total Air volume - cfm		21,500	21,500	21,500
Indoor Coils	Net face area (total) - sq. ft.		31.40	31.40	31.40
	Tube diameter - in.		3/8	3/8	3/8
	Number of rows		4	4	4
	Fins per inch		14	14	14
	Drain connection - No. and size		(1) 1 in. NPT	(1) 1 in. NPT	(1) 1 in. NPT
Expansion device type			Balance port TXV, removable head		
³ Indoor Blower and Kit Selection	Nominal motor output		5 hp, 7.5 hp, 10 hp		
	Maximum usable motor output (US Only)		5.75 hp, 8.63 hp, 11.5 hp		
	Motor - Kit kit number		5 hp Kit 5 660-810 rpm Kit 6 770-965 rpm Kit 7 570-720 rpm Kit 8 480-630 rpm Kit 9 410-535 rpm 7.5 hp Kit 3 715-880 rpm Kit 4 770-965 rpm 10 hp Kit 1 740-895 rpm Kit 2 870-1045 rpm		
	Blower wheel nom. D x W - in.		(2) 18 x 15	(2) 18 x 15	(2) 18 x 15
Filters	Type of filter		Fiberglass, disposable		
	Number and size - in.		(12) 20 x 20 x 2		
Electrical characteristics			208/230V, 460V or 575V - 60 hertz - 3 phase		

NOTE - Net capacity includes evaporator blower motor heat deduction. Gross capacity does not include evaporator blower motor heat deduction.

¹ AHRI Certified to AHRI Standard 340/360; 95°F outdoor air temperature and 80°F db/67°F wb entering evaporator air; minimum external duct static pressure.

³ Using total air volume and system static pressure requirements determine from blower performance tables rpm and motor output required. Maximum usable output of motors furnished are shown. In Canada, nominal motor output is also maximum usable motor output. If motors of comparable output are used, be sure to keep within the service factor limitations outlined on the motor nameplate.

RATINGS

NOTE – For Temperatures and Capacities not shown in tables, see bulletin – Cooling Unit Rating Table Correction Factor Data in Miscellaneous Engineering Data section.

20 TON HIGH EFFICIENCY LCH242H4V (1 COMPRESSOR OPERATING) - VARIABLE AIR VOLUME

Entering Wet Bulb Temperature	Total Air Volume	Outdoor Air Temperature Entering Outdoor Coil																			
		65°F					75°F					85°F					95°F				
		Total Cool Cap.	Comp. Motor Input	Sensible To Total Ratio (S/T)			Total Cool Cap.	Comp. Motor Input	Sensible To Total Ratio (S/T)			Total Cool Cap.	Comp. Motor Input	Sensible To Total Ratio (S/T)			Total Cool Cap.	Comp. Motor Input	Sensible To Total Ratio (S/T)		
				Dry Bulb					Dry Bulb					Dry Bulb					Dry Bulb		
cfm	kBtuh	kW	75°F	80°F	85°F	kBtuh	kW	75°F	80°F	85°F	kBtuh	kW	75°F	80°F	85°F	kBtuh	kW	75°F	80°F	85°F	
63°F	1600	47.2	2.44	0.62	0.7	0.79	45.3	2.83	0.62	0.7	0.79	43.1	3.25	0.61	0.7	0.79	40.9	3.72	0.6	0.7	0.8
	2000	51.5	2.44	0.63	0.73	0.82	49.6	2.83	0.63	0.73	0.83	47.6	3.26	0.63	0.73	0.83	45	3.73	0.63	0.74	0.85
	2400	55.2	2.44	0.65	0.76	0.86	53.2	2.84	0.65	0.76	0.87	50.9	3.27	0.65	0.77	0.88	48.2	3.74	0.65	0.78	0.89
67°F	1600	49.3	2.44	0.51	0.59	0.67	47.6	2.83	0.5	0.58	0.67	45.5	3.25	0.5	0.58	0.67	43.3	3.73	0.49	0.58	0.67
	2000	54.3	2.44	0.52	0.6	0.7	52.4	2.83	0.52	0.6	0.7	50.1	3.27	0.51	0.6	0.7	47.6	3.74	0.51	0.61	0.71
	2400	58.1	2.44	0.53	0.63	0.73	56.1	2.84	0.53	0.63	0.73	53.8	3.28	0.52	0.63	0.73	51	3.75	0.52	0.63	0.74
71°F	1600	51.7	2.44	0.41	0.49	0.57	49.9	2.83	0.4	0.49	0.56	47.9	3.26	0.39	0.48	0.56	45.5	3.74	0.38	0.47	0.56
	2000	56.8	2.44	0.41	0.5	0.58	54.9	2.84	0.41	0.5	0.58	52.6	3.27	0.4	0.5	0.58	50	3.75	0.39	0.49	0.58
	2400	60.9	2.43	0.42	0.52	0.6	58.8	2.84	0.41	0.51	0.6	56.4	3.28	0.4	0.51	0.6	53.5	3.75	0.4	0.51	0.61

20 TON HIGH EFFICIENCY LCH242H4V (2 COMPRESSORS OPERATING) - VARIABLE AIR VOLUME

Entering Wet Bulb Temperature	Total Air Volume	Outdoor Air Temperature Entering Outdoor Coil																			
		65°F					75°F					85°F					95°F				
		Total Cool Cap.	Comp. Motor Input	Sensible To Total Ratio (S/T)			Total Cool Cap.	Comp. Motor Input	Sensible To Total Ratio (S/T)			Total Cool Cap.	Comp. Motor Input	Sensible To Total Ratio (S/T)			Total Cool Cap.	Comp. Motor Input	Sensible To Total Ratio (S/T)		
				Dry Bulb					Dry Bulb					Dry Bulb					Dry Bulb		
cfm	kBtuh	kW	75°F	80°F	85°F	kBtuh	kW	75°F	80°F	85°F	kBtuh	kW	75°F	80°F	85°F	kBtuh	kW	75°F	80°F	85°F	
63°F	3200	106.4	4.89	0.63	0.71	0.78	102.2	5.67	0.63	0.71	0.78	97.6	6.52	0.62	0.71	0.79	92.3	7.46	0.61	0.71	0.8
	4000	114.4	4.89	0.64	0.73	0.82	109.9	5.68	0.64	0.73	0.82	105	6.54	0.63	0.74	0.83	99.3	7.48	0.63	0.74	0.84
	4800	120.9	4.89	0.66	0.76	0.85	116.2	5.69	0.65	0.76	0.86	110.7	6.55	0.65	0.77	0.86	105	7.5	0.66	0.78	0.88
67°F	3200	113.1	4.89	0.52	0.6	0.67	108.6	5.68	0.51	0.59	0.67	104	6.54	0.5	0.59	0.67	98.7	7.48	0.5	0.58	0.67
	4000	121.9	4.89	0.52	0.61	0.7	117.2	5.69	0.52	0.61	0.7	112	6.56	0.52	0.61	0.7	106.1	7.5	0.51	0.61	0.71
	4800	128.6	4.89	0.53	0.63	0.73	123.6	5.69	0.53	0.63	0.73	117.8	6.57	0.53	0.64	0.74	111.8	7.52	0.53	0.63	0.74
71°F	3200	119.9	4.89	0.42	0.5	0.57	115.4	5.69	0.41	0.49	0.57	110.6	6.56	0.4	0.49	0.56	105.1	7.5	0.39	0.48	0.56
	4000	129.2	4.88	0.42	0.5	0.58	124.4	5.69	0.41	0.5	0.59	119	6.57	0.4	0.5	0.59	113	7.53	0.4	0.5	0.59
	4800	136.4	4.88	0.42	0.51	0.61	131.4	5.7	0.41	0.51	0.61	125.4	6.58	0.41	0.51	0.61	119	7.54	0.4	0.51	0.62

20 TON HIGH EFFICIENCY LCH242H4V (3 COMPRESSORS OPERATING) - VARIABLE AIR VOLUME

Entering Wet Bulb Temperature	Total Air Volume	Outdoor Air Temperature Entering Outdoor Coil																			
		65°F					75°F					85°F					95°F				
		Total Cool Cap.	Comp. Motor Input	Sensible To Total Ratio (S/T)			Total Cool Cap.	Comp. Motor Input	Sensible To Total Ratio (S/T)			Total Cool Cap.	Comp. Motor Input	Sensible To Total Ratio (S/T)			Total Cool Cap.	Comp. Motor Input	Sensible To Total Ratio (S/T)		
				Dry Bulb					Dry Bulb					Dry Bulb					Dry Bulb		
cfm	kBtuh	kW	75°F	80°F	85°F	kBtuh	kW	75°F	80°F	85°F	kBtuh	kW	75°F	80°F	85°F	kBtuh	kW	75°F	80°F	85°F	
63°F	4800	190.6	7.35	0.69	0.82	0.9	182.8	8.56	0.7	0.83	0.91	173.9	9.86	0.7	0.84	0.91	164.5	11.27	0.71	0.86	0.92
	6000	201.5	7.35	0.73	0.87	0.93	193.6	8.57	0.74	0.87	0.94	184.9	9.88	0.75	0.88	0.95	175.5	11.31	0.77	0.89	0.96
	7200	211.3	7.34	0.78	0.9	0.96	203.1	8.58	0.78	0.9	0.97	193.9	9.89	0.8	0.91	0.98	183.9	11.33	0.82	0.92	0.99
67°F	4800	202.1	7.35	0.56	0.67	0.79	194	8.57	0.56	0.67	0.79	184.6	9.88	0.56	0.68	0.81	174.7	11.3	0.56	0.69	0.82
	6000	212.7	7.34	0.58	0.71	0.85	203.9	8.58	0.58	0.72	0.85	194.2	9.9	0.59	0.73	0.86	183.2	11.32	0.58	0.74	0.87
	7200	220.2	7.34	0.61	0.76	0.88	211.2	8.58	0.61	0.76	0.88	201.1	9.91	0.61	0.78	0.89	189.8	11.34	0.62	0.79	0.9
71°F	4800	213.3	7.34	0.43	0.54	0.65	205.1	8.58	0.43	0.54	0.66	195.5	9.9	0.42	0.54	0.66	185.2	11.33	0.41	0.55	0.67
	6000	224.4	4.92	0.44	0.55	0.66	215.7	8.58	0.43	0.57	0.7	205.5	9.91	0.43	0.57	0.7	194.4	11.35	0.43	0.58	0.72
	7200	232.4	4.91	0.45	0.56	0.68	223.4	8.58	0.45	0.6	0.74	212.7	9.92	0.45	0.6	0.75	201	11.37	0.44	0.61	0.77

20 TON HIGH EFFICIENCY LCH242H4V (ALL COMPRESSORS OPERATING) - VARIABLE AIR VOLUME

Entering Wet Bulb Temperature	Total Air Volume	Outdoor Air Temperature Entering Outdoor Coil																			
		85°F					95°F					105°F					115°F				
		Total Cool Cap.	Comp. Motor Input	Sensible To Total Ratio (S/T)			Total Cool Cap.	Comp. Motor Input	Sensible To Total Ratio (S/T)			Total Cool Cap.	Comp. Motor Input	Sensible To Total Ratio (S/T)			Total Cool Cap.	Comp. Motor Input	Sensible To Total Ratio (S/T)		
				Dry Bulb					Dry Bulb					Dry Bulb					Dry Bulb		
cfm	kBtuh	kW	75°F	80°F	85°F	kBtuh	kW	75°F	80°F	85°F	kBtuh	kW	75°F	80°F	85°F	kBtuh	kW	75°F	80°F	85°F	
63°F	6400	244	13.17	0.71	0.83	0.94	231.5	15.08	0.71	0.84	0.96	217.6	17.18	0.73	0.86	0.98	202.5	19.57	0.73	0.88	1
	8000	258	13.19	0.75	0.89	1	244.4	15.1	0.76	0.91	1	229.6	17.21	0.78	0.93	1	213.7	19.61	0.8	0.96	1
	9600	268.4	13.21	0.8	0.95	1	254.2	15.13	0.82	0.97	1	238.9	17.25	0.84	0.99	1	222.6	19.65	0.86	1	1
67°F	6400	255.5	13.19	0.55	0.68	0.8	241.4	15.09	0.56	0.69	0.81	226.8	17.2	0.55	0.7	0.83	210.4	19.59	0.56	0.71	0.85
	8000	267.3	13.21	0.58	0.72	0.86	252.6	15.12	0.58	0.74	0.88	236.9	17.24	0.59	0.76	0.9	220.3	19.63	0.59	0.77	0.92
	9600	276.4	13.22	0.61	0.78	0.92	261.4	15.15	0.62	0.79	0.94	245.5	17.27	0.63	0.81	0.97	228.4	19.67	0.64	0.83	0.99
71°F	6400	271.1	13.21	0.42	0.55	0.66	256.7	15.13	0.41	0.54	0.67	240.9	17.26	0.41	0.55	0.68	224.1	19.65	0.4	0.55	0.69
	8000	283.4	13.23	0.42	0.57	0.7	267.9	15.17	0.42	0.58	0.72	251.4	17.29	0.42	0.58	0.74	233	19.7	0.41	0.59	0.76
	9600	291.8	13.24	0.43	0.6	0.76	275.4	15.18	0.43	0.61	0.78	258.1	17.32	0.43	0.62	0.8	239.1	19.72	0.43	0.63	0.82

RATINGS

NOTE – For Temperatures and Capacities not shown in tables, see bulletin – Cooling Unit Rating Table Correction Factor Data in Miscellaneous Engineering Data section.

25 TON HIGH EFFICIENCY LCH300H4B (1ST STAGE) - CONSTANT AIR VOLUME

Entering Wet Bulb Temperature	Total Air Volume	Outdoor Air Temperature Entering Outdoor Coil																							
		65°F						75°F						85°F						95°F					
		Total Cool Cap.	Comp. Motor Input	Sensible To Total Ratio (S/T)			Total Cool Cap.	Comp. Motor Input	Sensible To Total Ratio (S/T)			Total Cool Cap.	Comp. Motor Input	Sensible To Total Ratio (S/T)			Total Cool Cap.	Comp. Motor Input	Sensible To Total Ratio (S/T)						
				Dry Bulb					Dry Bulb					Dry Bulb					Dry Bulb						
cfm	kBtuh	kW	75°F	80°F	85°F	kBtuh	kW	75°F	80°F	85°F	kBtuh	kW	75°F	80°F	85°F	kBtuh	kW	75°F	80°F	85°F					
63°F	8000	160.5	7.35	0.73	0.84	0.95	153.9	8.21	0.73	0.85	0.96	146.7	9.16	0.74	0.86	0.98	139	10.27	0.74	0.88	0.99				
	10000	169.9	7.48	0.77	0.9	1	162.5	8.33	0.78	0.91	1	154.9	9.29	0.79	0.93	1	147	10.38	0.8	0.94	1				
	12000	176.7	7.58	0.81	0.95	1	169.1	8.42	0.82	0.97	1	161.4	9.38	0.83	0.98	1	153.2	10.47	0.84	0.99	1				
67°F	8000	171.1	7.5	0.58	0.7	0.81	164	8.35	0.58	0.71	0.82	156.6	9.3	0.58	0.71	0.83	148.5	10.39	0.58	0.72	0.84				
	10000	180.3	7.63	0.61	0.75	0.87	172.4	8.47	0.61	0.76	0.89	164.4	9.42	0.61	0.76	0.9	156.2	10.51	0.62	0.78	0.91				
	12000	186.5	7.73	0.64	0.8	0.93	178.8	8.57	0.64	0.81	0.94	170.3	9.51	0.65	0.81	0.96	161.5	10.59	0.65	0.83	0.97				
71°F	8000	182.5	7.67	0.44	0.56	0.68	175.1	8.51	0.44	0.56	0.68	167.3	9.46	0.43	0.56	0.69	159	10.55	0.43	0.57	0.7				
	10000	191.8	7.8	0.45	0.6	0.73	183.9	8.64	0.45	0.59	0.74	175.6	9.59	0.45	0.6	0.75	166.7	10.67	0.45	0.6	0.76				
	12000	198.3	7.91	0.47	0.62	0.78	190.1	8.74	0.47	0.63	0.79	181.8	9.69	0.47	0.64	0.8	172.1	10.77	0.46	0.64	0.81				

25 TON HIGH EFFICIENCY LCH300H4B (2ND STAGE) - CONSTANT AIR VOLUME

Entering Wet Bulb Temperature	Total Air Volume	Outdoor Air Temperature Entering Outdoor Coil																							
		85°F						95°F						105°F						115°F					
		Total Cool Cap.	Comp. Motor Input	Sensible To Total Ratio (S/T)			Total Cool Cap.	Comp. Motor Input	Sensible To Total Ratio (S/T)			Total Cool Cap.	Comp. Motor Input	Sensible To Total Ratio (S/T)			Total Cool Cap.	Comp. Motor Input	Sensible To Total Ratio (S/T)						
				Dry Bulb					Dry Bulb					Dry Bulb					Dry Bulb						
cfm	kBtuh	kW	75°F	80°F	85°F	kBtuh	kW	75°F	80°F	85°F	kBtuh	kW	75°F	80°F	85°F	kBtuh	kW	75°F	80°F	85°F					
63°F	8000	296.2	18.34	0.74	0.87	0.98	281.2	20.54	0.75	0.88	1	264.8	23.12	0.76	0.9	1	245.8	26.15	0.77	0.92	1				
	10000	312	18.57	0.79	0.94	1	296.6	20.78	0.8	0.95	1	279.7	23.34	0.82	0.97	1	260	26.33	0.84	0.99	1				
	12000	324.6	18.75	0.84	0.99	1	308.9	20.94	0.85	1	1	292.8	23.53	0.87	1	1	275	26.56	0.89	1	1				
67°F	8000	316.1	18.62	0.58	0.71	0.84	300.8	20.82	0.58	0.72	0.85	283.8	23.4	0.58	0.73	0.87	263.9	26.39	0.59	0.75	0.89				
	10000	331.9	18.86	0.61	0.77	0.91	315.7	21.05	0.62	0.78	0.92	298	23.61	0.63	0.8	0.94	276.9	26.57	0.63	0.81	0.97				
	12000	343.8	19.04	0.65	0.82	0.97	326.6	21.22	0.65	0.83	0.98	308.3	23.78	0.66	0.85	1	286.7	26.73	0.67	0.87	1				
71°F	8000	336.9	18.93	0.43	0.57	0.69	321	21.12	0.43	0.57	0.7	303.8	23.7	0.42	0.57	0.71	283.2	26.66	0.42	0.57	0.73				
	10000	353.5	19.19	0.45	0.6	0.75	336.7	21.38	0.45	0.61	0.76	318.6	23.94	0.45	0.62	0.78	296.9	26.89	0.44	0.62	0.79				
	12000	365.8	19.38	0.47	0.64	0.8	347.7	21.55	0.46	0.64	0.81	328.6	24.1	0.46	0.65	0.83	306.2	27.06	0.46	0.67	0.85				

25 TON HIGH EFFICIENCY LCH300H4M (1ST STAGE) - MSAV® (MULTI-STAGE AIR VOLUME)

Entering Wet Bulb Temperature	Total Air Volume	Outdoor Air Temperature Entering Outdoor Coil																							
		65°F						75°F						85°F						95°F					
		Total Cool Cap.	Comp. Motor Input	Sensible To Total Ratio (S/T)			Total Cool Cap.	Comp. Motor Input	Sensible To Total Ratio (S/T)			Total Cool Cap.	Comp. Motor Input	Sensible To Total Ratio (S/T)			Total Cool Cap.	Comp. Motor Input	Sensible To Total Ratio (S/T)						
				Dry Bulb					Dry Bulb					Dry Bulb					Dry Bulb						
cfm	kBtuh	kW	75°F	80°F	85°F	kBtuh	kW	75°F	80°F	85°F	kBtuh	kW	75°F	80°F	85°F	kBtuh	kW	75°F	80°F	85°F					
63°F	4000	157.6	7.58	0.71	0.82	0.93	152	8.45	0.72	0.83	0.94	146	9.42	0.73	0.85	0.96	139.3	10.52	0.74	0.86	0.98				
	5000	166.4	7.72	0.74	0.87	0.99	160.3	8.58	0.75	0.89	1	153.5	9.55	0.77	0.9	1	146.4	10.64	0.78	0.92	1				
	6000	172.9	7.81	0.78	0.92	1	166.3	8.68	0.79	0.94	1	159.4	9.64	0.8	0.96	1	151.8	10.73	0.82	0.98	1				
67°F	4000	165.1	7.7	0.57	0.68	0.79	159.3	8.56	0.58	0.69	0.8	153	9.53	0.58	0.7	0.82	146.2	10.64	0.59	0.71	0.83				
	5000	174.5	7.84	0.59	0.72	0.84	168.2	8.71	0.6	0.73	0.86	161.4	9.68	0.61	0.74	0.87	153.9	10.77	0.62	0.76	0.89				
	6000	181.4	7.95	0.61	0.76	0.89	174.6	8.81	0.62	0.77	0.91	167.4	9.78	0.63	0.78	0.93	159.5	10.87	0.64	0.8	0.95				
71°F	4000	171.7	7.8	0.45	0.56	0.66	165.8	8.67	0.45	0.56	0.67	159.5	9.65	0.45	0.57	0.68	152.4	10.75	0.45	0.57	0.69				
	5000	181.8	7.96	0.45	0.58	0.7	175.5	8.83	0.45	0.59	0.71	168.3	9.8	0.46	0.59	0.72	160.6	10.89	0.46	0.6	0.74				
	6000	189.2	8.08	0.47	0.6	0.74	182.3	8.95	0.46	0.61	0.75	174.9	9.91	0.47	0.62	0.76	166.7	11.01	0.46	0.63	0.78				

25 TON HIGH EFFICIENCY LCH300H4M (2ND STAGE) - MSAV® (MULTI-STAGE AIR VOLUME)

Entering Wet Bulb Temperature	Total Air Volume	Outdoor Air Temperature Entering Outdoor Coil																							
		85°F						95°F						105°F						115°F					
		Total Cool Cap.	Comp. Motor Input	Sensible To Total Ratio (S/T)			Total Cool Cap.	Comp. Motor Input	Sensible To Total Ratio (S/T)			Total Cool Cap.	Comp. Motor Input	Sensible To Total Ratio (S/T)			Total Cool Cap.	Comp. Motor Input	Sensible To Total Ratio (S/T)						
				Dry Bulb					Dry Bulb					Dry Bulb					Dry Bulb						
cfm	kBtuh	kW	75°F	80°F	85°F	kBtuh	kW	75°F	80°F	85°F	kBtuh	kW	75°F	80°F	85°F	kBtuh	kW	75°F	80°F	85°F					
63°F	8000	308.3	19.12	0.72	0.85	0.94	294.8	21.33	0.74	0.86	0.95	279.7	23.81	0.75	0.88	0.97	263.4	26.66	0.77	0.89	1				
	10000	324.8	19.41	0.77	0.9	1	309.6	21.59	0.79	0.91	1	293.4	24.07	0.8	0.93	1	276	26.92	0.83	0.95	1				
	12000	336.6	19.63	0.82	0.94	1	320.9	21.8	0.83	0.96	1	303.8	24.28	0.85	0.98	1	285.5	27.12	0.87	1	1				
67°F	8000	323.4	19.39	0.57	0.7	0.82	307.9	21.55	0.58	0.71	0.83	291.3	24.03	0.58	0.72	0.85	272.6	26.84	0.59	0.74	0.87				
	10000	336.5	19.62	0.6	0.75	0.87	319.9	21.78	0.6	0.76	0.89	302.3	24.25	0.62	0.78	0.91	283.2	27.06	0.64	0.8	0.93				
	12000	346.3	19.79	0.63	0.8	0.92	329.4	21.96	0.65	0.81	0.94	311.1	24.42	0.66	0.83	0.96	291.7	27.25	0.67	0.85	0.99				
71°F	8000	341.9	19.72	0.43	0.55	0.67	325.4	21.88	0.43	0.56	0.68	307.1	24.35	0.43	0.58	0.7	288.4	27.17	0.43	0.58	0.73				
	10000	355	19.95	0.44	0.58	0.72	337.6	22.12	0.44	0.59	0.75	318.5	24.57	0.44	0.61	0.76	298.1	27.38	0.45	0.62	0.79				
	12000	364.5	20.13	0.44	0.61	0.78	345.9	22.28	0.45	0.63	0.8	326.3	24.74	0.46	0.65	0.82	304.7	27.53	0.47	0.67	0.84				

RATINGS

NOTE – For Temperatures and Capacities not shown in tables, see bulletin – Cooling Unit Rating Table Correction Factor Data in Miscellaneous Engineering Data section.

25 TON HIGH EFFICIENCY LCH300H4V (1 COMPRESSOR OPERATING) - VARIABLE AIR VOLUME

Entering Wet Bulb Temperature	Total Air Volume	Outdoor Air Temperature Entering Outdoor Coil																			
		65°F					75°F					85°F					95°F				
		Total Cool Cap.	Comp. Motor Input	Sensible To Total Ratio (S/T)			Total Cool Cap.	Comp. Motor Input	Sensible To Total Ratio (S/T)			Total Cool Cap.	Comp. Motor Input	Sensible To Total Ratio (S/T)			Total Cool Cap.	Comp. Motor Input	Sensible To Total Ratio (S/T)		
				Dry Bulb					Dry Bulb					Dry Bulb					Dry Bulb		
cfm	kBtuh	kW	75°F	80°F	85°F	kBtuh	kW	75°F	80°F	85°F	kBtuh	kW	75°F	80°F	85°F	kBtuh	kW	75°F	80°F	85°F	
63°F	2000	61.6	3.65	0.63	0.7	0.78	58.9	4.07	0.63	0.71	0.79	55.9	4.57	0.62	0.7	0.79	52.7	5.13	0.61	0.7	0.8
	2500	67.4	3.68	0.63	0.72	0.81	64.5	4.1	0.63	0.73	0.82	61.5	4.59	0.63	0.73	0.83	58.2	5.15	0.63	0.74	0.84
	3000	72.3	3.73	0.65	0.75	0.84	69.2	4.15	0.65	0.75	0.85	66	4.63	0.65	0.76	0.87	62.4	5.19	0.66	0.77	0.88
67°F	2000	64.9	3.67	0.53	0.6	0.67	61.6	4.09	0.52	0.59	0.67	58.8	4.58	0.51	0.59	0.67	55.8	5.15	0.5	0.59	0.67
	2500	70.9	3.72	0.52	0.6	0.69	68	4.14	0.52	0.6	0.69	64.9	4.62	0.52	0.61	0.7	61.5	5.18	0.51	0.61	0.7
	3000	76.2	3.76	0.53	0.62	0.72	73.1	4.17	0.53	0.62	0.72	69.7	4.64	0.53	0.63	0.73	66	5.2	0.53	0.63	0.74
71°F	2000	67.3	3.68	0.42	0.5	0.56	64.6	4.11	0.41	0.49	0.57	61.8	4.59	0.4	0.49	0.57	58.7	5.16	0.39	0.48	0.56
	2500	74.2	3.73	0.42	0.51	0.58	71.2	4.15	0.41	0.5	0.58	68	4.63	0.41	0.5	0.59	64.6	5.19	0.4	0.5	0.59
	3000	79.8	3.79	0.42	0.51	0.6	76.6	4.2	0.42	0.51	0.6	73	4.68	0.41	0.51	0.61	69.3	5.23	0.41	0.51	0.61

25 TON HIGH EFFICIENCY LCH300H4V (2 COMPRESSORS OPERATING) - VARIABLE AIR VOLUME

Entering Wet Bulb Temperature	Total Air Volume	Outdoor Air Temperature Entering Outdoor Coil																			
		65°F					75°F					85°F					95°F				
		Total Cool Cap.	Comp. Motor Input	Sensible To Total Ratio (S/T)			Total Cool Cap.	Comp. Motor Input	Sensible To Total Ratio (S/T)			Total Cool Cap.	Comp. Motor Input	Sensible To Total Ratio (S/T)			Total Cool Cap.	Comp. Motor Input	Sensible To Total Ratio (S/T)		
				Dry Bulb					Dry Bulb					Dry Bulb					Dry Bulb		
cfm	kBtuh	kW	75°F	80°F	85°F	kBtuh	kW	75°F	80°F	85°F	kBtuh	kW	75°F	80°F	85°F	kBtuh	kW	75°F	80°F	85°F	
63°F	4000	137.9	7.46	0.61	0.68	0.76	131.9	8.29	0.62	0.71	0.78	125.6	9.23	0.63	0.71	0.79	118.8	10.31	0.62	0.71	0.8
	5000	149.2	7.52	0.65	0.73	0.81	142.4	8.37	0.63	0.73	0.81	135.4	9.31	0.64	0.74	0.83	128.1	10.4	0.63	0.74	0.84
	6000	157.3	7.59	0.65	0.75	0.84	150.7	8.44	0.66	0.76	0.85	143.3	9.38	0.66	0.77	0.86	135.4	10.44	0.66	0.77	0.87
67°F	4000	146.8	7.51	0.53	0.6	0.67	140.8	8.35	0.52	0.6	0.67	134	9.31	0.51	0.59	0.68	126.9	10.37	0.51	0.59	0.68
	5000	158.5	7.61	0.53	0.61	0.69	151.9	8.44	0.53	0.61	0.7	144.7	9.39	0.52	0.61	0.7	136.9	10.46	0.51	0.62	0.7
	6000	167.6	7.7	0.54	0.62	0.72	160.5	8.53	0.53	0.63	0.72	152.7	9.46	0.53	0.64	0.74	144.4	10.53	0.53	0.64	0.74
71°F	4000	155.5	7.58	0.43	0.5	0.57	149.2	8.42	0.42	0.49	0.57	142.5	9.37	0.41	0.49	0.57	135.4	10.45	0.4	0.49	0.57
	5000	168.1	7.71	0.43	0.51	0.59	161.2	8.52	0.42	0.5	0.58	154.1	9.47	0.41	0.5	0.59	146.1	10.55	0.41	0.49	0.59
	6000	177.8	7.79	0.43	0.52	0.6	170.5	8.62	0.42	0.51	0.61	162.2	9.56	0.41	0.52	0.61	153.7	10.63	0.4	0.51	0.61

25 TON HIGH EFFICIENCY LCH300H4V (3 COMPRESSORS OPERATING) - VARIABLE AIR VOLUME

Entering Wet Bulb Temperature	Total Air Volume	Outdoor Air Temperature Entering Outdoor Coil																			
		65°F					75°F					85°F					95°F				
		Total Cool Cap.	Comp. Motor Input	Sensible To Total Ratio (S/T)			Total Cool Cap.	Comp. Motor Input	Sensible To Total Ratio (S/T)			Total Cool Cap.	Comp. Motor Input	Sensible To Total Ratio (S/T)			Total Cool Cap.	Comp. Motor Input	Sensible To Total Ratio (S/T)		
				Dry Bulb					Dry Bulb					Dry Bulb					Dry Bulb		
cfm	kBtuh	kW	75°F	80°F	85°F	kBtuh	kW	75°F	80°F	85°F	kBtuh	kW	75°F	80°F	85°F	kBtuh	kW	75°F	80°F	85°F	
63°F	6000	247.6	11.46	0.69	0.81	0.9	236.6	12.72	0.7	0.82	0.9	224.8	14.12	0.7	0.83	0.91	212.3	15.72	0.71	0.84	0.92
	7500	261.7	11.61	0.72	0.86	0.93	250.1	12.85	0.73	0.87	0.93	237.6	14.24	0.74	0.88	0.94	225.2	15.86	0.76	0.89	0.95
	9000	273	11.73	0.76	0.89	0.95	261.6	12.98	0.77	0.9	0.96	249.3	14.38	0.79	0.9	0.97	236.2	16	0.8	0.91	0.98
67°F	6000	262.6	11.63	0.56	0.66	0.77	251.2	12.87	0.56	0.67	0.78	238.9	14.27	0.56	0.68	0.8	225.8	15.87	0.56	0.69	0.81
	7500	276.9	11.78	0.58	0.7	0.83	264.6	13.01	0.58	0.71	0.84	251.5	14.41	0.58	0.72	0.86	237.2	15.99	0.59	0.73	0.87
	9000	287.4	11.89	0.6	0.74	0.87	274.3	13.12	0.6	0.75	0.88	260.3	14.52	0.6	0.77	0.89	245.2	16.11	0.61	0.79	0.89
71°F	6000	277	11.78	0.43	0.54	0.64	265.4	13.03	0.43	0.54	0.65	252.4	14.43	0.42	0.55	0.65	239.1	16.03	0.42	0.55	0.66
	7500	291.9	11.95	0.44	0.57	0.68	279.3	13.19	0.44	0.57	0.69	266	14.59	0.43	0.57	0.7	251.2	16.18	0.43	0.57	0.71
	9000	303.1	12.08	0.45	0.59	0.72	289.6	13.32	0.45	0.6	0.73	275.3	14.71	0.44	0.6	0.74	259.9	16.3	0.44	0.6	0.76

25 TON HIGH EFFICIENCY LCH300H4V (ALL COMPRESSORS OPERATING) - VARIABLE AIR VOLUME

Entering Wet Bulb Temperature	Total Air Volume	Outdoor Air Temperature Entering Outdoor Coil																			
		85°F					95°F					105°F					115°F				
		Total Cool Cap.	Comp. Motor Input	Sensible To Total Ratio (S/T)			Total Cool Cap.	Comp. Motor Input	Sensible To Total Ratio (S/T)			Total Cool Cap.	Comp. Motor Input	Sensible To Total Ratio (S/T)			Total Cool Cap.	Comp. Motor Input	Sensible To Total Ratio (S/T)		
				Dry Bulb					Dry Bulb					Dry Bulb					Dry Bulb		
cfm	kBtuh	kW	75°F	80°F	85°F	kBtuh	kW	75°F	80°F	85°F	kBtuh	kW	75°F	80°F	85°F	kBtuh	kW	75°F	80°F	85°F	
63°F	8000	308.3	19.12	0.72	0.85	0.94	294.8	21.33	0.74	0.86	0.95	279.7	23.81	0.75	0.88	0.97	263.4	26.66	0.77	0.89	1
	10000	324.8	19.41	0.77	0.9	1	309.6	21.59	0.79	0.91	1	293.4	24.07	0.8	0.93	1	276	26.92	0.83	0.95	1
	12000	336.6	19.63	0.82	0.94	1	320.9	21.8	0.83	0.96	1	303.8	24.28	0.85	0.98	1	285.5	27.12	0.87	1	1
67°F	8000	323.4	19.39	0.57	0.7	0.82	307.9	21.55	0.58	0.71	0.83	291.3	24.03	0.58	0.72	0.85	272.6	26.84	0.59	0.74	0.87
	10000	336.5	19.62	0.6	0.75	0.87	319.9	21.78	0.6	0.76	0.89	302.3	24.25	0.62	0.78	0.91	283.2	27.06	0.64	0.8	0.93
	12000	346.3	19.79	0.63	0.8	0.92	329.4	21.96	0.65	0.81	0.94	311.1	24.42	0.66	0.83	0.96	291.7	27.25	0.67	0.85	0.99
71°F	8000	341.9	19.72	0.43	0.55	0.67	325.4	21.88	0.43	0.56	0.68	307.1	24.35	0.43	0.58	0.7	288.4	27.17	0.43	0.58	0.73
	10000	355	19.95	0.44	0.58	0.72	337.6	22.12	0.44	0.59	0.75	318.5	24.57	0.44	0.61	0.76	298.1	27.38	0.45	0.62	0.79
	12000	364.5	20.13	0.44	0.61	0.78	345.9	22.28	0.45	0.63	0.8	326.3	24.74	0.46	0.65	0.82	304.7	27.53	0.47	0.67	0.84

RATINGS

NOTE – For Temperatures and Capacities not shown in tables, see bulletin – Cooling Unit Rating Table Correction Factor Data in Miscellaneous Engineering Data section.

30 TON HIGH EFFICIENCY LCH360H4B (1ST STAGE) - CONSTANT AIR VOLUME

Entering Wet Bulb Temperature	Total Air Volume	Outdoor Air Temperature Entering Outdoor Coil																							
		65°F						75°F						85°F						95°F					
		Total Cool Cap.	Comp. Motor Input	Sensible To Total Ratio (S/T)			Total Cool Cap.	Comp. Motor Input	Sensible To Total Ratio (S/T)			Total Cool Cap.	Comp. Motor Input	Sensible To Total Ratio (S/T)			Total Cool Cap.	Comp. Motor Input	Sensible To Total Ratio (S/T)						
				Dry Bulb					Dry Bulb					Dry Bulb					Dry Bulb						
cfm	kBtuh	kW	75°F	80°F	85°F	kBtuh	kW	75°F	80°F	85°F	kBtuh	kW	75°F	80°F	85°F	kBtuh	kW	75°F	80°F	85°F					
63°F	9440	193.7	9.57	0.71	0.83	0.94	185.6	10.61	0.71	0.84	0.96	177.6	11.79	0.72	0.85	0.97	168.9	13.16	0.72	0.86	0.98				
	11800	204.3	9.73	0.75	0.89	1	195.5	10.76	0.76	0.9	1	187	11.95	0.77	0.92	1	177.8	13.31	0.78	0.93	1				
	14160	212.1	9.86	0.8	0.95	1	202.9	10.89	0.81	0.96	1	194.1	12.07	0.82	0.98	1	184.9	13.44	0.83	0.99	1				
67°F	9440	206.1	9.76	0.57	0.68	0.8	197.7	10.8	0.56	0.69	0.81	189	11.98	0.56	0.69	0.82	180	13.35	0.56	0.7	0.83				
	11800	215.9	9.92	0.59	0.73	0.86	206.7	10.95	0.6	0.74	0.87	197.7	12.13	0.6	0.75	0.89	188.1	13.5	0.6	0.76	0.9				
	14160	222.9	10.04	0.62	0.78	0.92	213.4	11.07	0.62	0.79	0.94	204.1	12.24	0.63	0.8	0.95	194.4	13.6	0.63	0.81	0.97				
71°F	9440	218.8	9.97	0.43	0.55	0.66	209.8	11	0.43	0.56	0.67	200.8	12.19	0.43	0.55	0.67	191.4	13.55	0.42	0.55	0.68				
	11800	228.7	10.14	0.45	0.58	0.71	219.1	11.17	0.44	0.58	0.72	210	12.35	0.44	0.59	0.73	200	13.71	0.43	0.59	0.74				
	14160	236.2	10.27	0.46	0.61	0.76	226.3	11.3	0.45	0.62	0.77	216.6	12.47	0.46	0.62	0.78	206.8	13.83	0.45	0.63	0.79				

30 TON HIGH EFFICIENCY LCH360H4B (2ND STAGE) - CONSTANT AIR VOLUME

Entering Wet Bulb Temperature	Total Air Volume	Outdoor Air Temperature Entering Outdoor Coil																							
		85°F						95°F						105°F						115°F					
		Total Cool Cap.	Comp. Motor Input	Sensible To Total Ratio (S/T)			Total Cool Cap.	Comp. Motor Input	Sensible To Total Ratio (S/T)			Total Cool Cap.	Comp. Motor Input	Sensible To Total Ratio (S/T)			Total Cool Cap.	Comp. Motor Input	Sensible To Total Ratio (S/T)						
				Dry Bulb					Dry Bulb					Dry Bulb					Dry Bulb						
cfm	kBtuh	kW	75°F	80°F	85°F	kBtuh	kW	75°F	80°F	85°F	kBtuh	kW	75°F	80°F	85°F	kBtuh	kW	75°F	80°F	85°F					
63°F	9440	357.9	23.62	0.72	0.85	0.98	339.6	26.32	0.73	0.87	0.99	320.3	29.45	0.74	0.88	1	298.7	33.06	0.75	0.91	1				
	11800	376.2	23.92	0.77	0.92	1	356.7	26.61	0.78	0.94	1	336.8	29.76	0.8	0.96	1	314.1	33.33	0.82	0.98	1				
	14160	390.1	24.16	0.82	0.98	1	371	26.86	0.84	0.99	1	351.1	30	0.85	1	1	329.1	33.62	0.88	1	1				
67°F	9440	380.8	24	0.57	0.7	0.82	361.9	26.69	0.57	0.7	0.83	341.9	29.83	0.57	0.71	0.85	318.5	33.41	0.57	0.73	0.87				
	11800	398.8	24.3	0.6	0.75	0.89	378.5	27.01	0.6	0.76	0.91	357.2	30.12	0.61	0.78	0.93	332.8	33.7	0.62	0.8	0.96				
	14160	411.3	24.53	0.63	0.81	0.96	390.7	27.22	0.64	0.82	0.98	368.6	30.34	0.64	0.83	0.99	342.8	33.9	0.65	0.86	1				
71°F	9440	403.5	24.4	0.43	0.55	0.68	383.9	27.09	0.42	0.55	0.68	363.4	30.23	0.42	0.56	0.69	339.3	33.82	0.41	0.56	0.71				
	11800	422.3	24.72	0.44	0.59	0.73	401.5	27.42	0.44	0.59	0.74	379.4	30.54	0.43	0.6	0.76	353.9	34.12	0.43	0.61	0.78				
	14160	435	24.95	0.45	0.62	0.79	414.7	27.65	0.45	0.63	0.8	390.6	30.75	0.45	0.63	0.81	363.9	34.32	0.45	0.65	0.84				

30 TON HIGH EFFICIENCY LCH360H4M (1ST STAGE) - MSAV® (MULTI-STAGE AIR VOLUME)

Entering Wet Bulb Temperature	Total Air Volume	Outdoor Air Temperature Entering Outdoor Coil																							
		65°F						75°F						85°F						95°F					
		Total Cool Cap.	Comp. Motor Input	Sensible To Total Ratio (S/T)			Total Cool Cap.	Comp. Motor Input	Sensible To Total Ratio (S/T)			Total Cool Cap.	Comp. Motor Input	Sensible To Total Ratio (S/T)			Total Cool Cap.	Comp. Motor Input	Sensible To Total Ratio (S/T)						
				Dry Bulb					Dry Bulb					Dry Bulb					Dry Bulb						
cfm	kBtuh	kW	75°F	80°F	85°F	kBtuh	kW	75°F	80°F	85°F	kBtuh	kW	75°F	80°F	85°F	kBtuh	kW	75°F	80°F	85°F					
63°F	4800	188.6	9.73	0.7	0.81	0.92	181.6	10.79	0.7	0.82	0.94	174	11.99	0.71	0.83	0.95	165.9	13.35	0.72	0.85	0.97				
	6000	198.4	9.9	0.73	0.86	0.98	190.9	10.97	0.74	0.88	1	182.6	12.16	0.75	0.89	1	173.7	13.52	0.76	0.91	1				
	7200	205.5	10.03	0.77	0.91	1	197.7	11.09	0.78	0.93	1	189.1	12.29	0.79	0.95	1	180.1	13.64	0.81	0.97	1				
67°F	4800	197.2	9.88	0.56	0.67	0.78	190	10.95	0.57	0.68	0.79	182.2	12.15	0.57	0.69	0.8	173.7	13.51	0.58	0.7	0.82				
	6000	207.8	10.07	0.59	0.71	0.83	200	11.13	0.59	0.72	0.85	191.5	12.33	0.59	0.73	0.86	182.5	13.7	0.6	0.74	0.88				
	7200	215.4	10.21	0.61	0.75	0.88	207.1	11.27	0.61	0.76	0.9	198.2	12.47	0.62	0.77	0.92	188.8	13.83	0.63	0.79	0.94				
71°F	4800	204.9	10.02	0.44	0.55	0.65	197.7	11.09	0.44	0.55	0.66	189.9	12.3	0.44	0.56	0.67	181	13.66	0.43	0.56	0.68				
	6000	216.1	10.22	0.45	0.57	0.69	208.2	11.29	0.44	0.58	0.7	199.7	12.5	0.45	0.58	0.71	190.3	13.86	0.45	0.59	0.72				
	7200	224.4	10.38	0.45	0.6	0.73	215.7	11.44	0.45	0.6	0.74	206.6	12.64	0.45	0.61	0.75	197	14.02	0.45	0.62	0.77				

30 TON HIGH EFFICIENCY LCH360H4M (2ND STAGE) - MSAV® (MULTI-STAGE AIR VOLUME)

Entering Wet Bulb Temperature	Total Air Volume	Outdoor Air Temperature Entering Outdoor Coil																							
		85°F						95°F						105°F						115°F					
		Total Cool Cap.	Comp. Motor Input	Sensible To Total Ratio (S/T)			Total Cool Cap.	Comp. Motor Input	Sensible To Total Ratio (S/T)			Total Cool Cap.	Comp. Motor Input	Sensible To Total Ratio (S/T)			Total Cool Cap.	Comp. Motor Input	Sensible To Total Ratio (S/T)						
				Dry Bulb					Dry Bulb					Dry Bulb					Dry Bulb						
cfm	kBtuh	kW	75°F	80°F	85°F	kBtuh	kW	75°F	80°F	85°F	kBtuh	kW	75°F	80°F	85°F	kBtuh	kW	75°F	80°F	85°F					
63°F	9600	366.9	24.6	0.71	0.84	0.94	350	27.35	0.72	0.85	0.95	332.2	30.52	0.74	0.87	0.97	312.1	34.14	0.76	0.89	0.99				
	12000	385.3	24.99	0.76	0.89	0.99	366.8	27.74	0.78	0.91	1	347.1	30.89	0.79	0.93	1	325.6	34.48	0.81	0.95	1				
	14400	398.1	25.26	0.81	0.94	1	378.9	28.01	0.83	0.96	1	358.6	31.15	0.84	0.98	1	336.4	34.78	0.86	1	1				
67°F	9600	384.1	24.96	0.56	0.69	0.82	365.7	27.7	0.56	0.7	0.83	345.3	30.82	0.58	0.71	0.84	323.1	34.42	0.59	0.74	0.86				
	12000	398.9	25.26	0.59	0.73	0.87	379	28	0.6	0.75	0.88	357.3	31.12	0.6	0.78	0.9	334.9	34.72	0.62	0.79	0.93				
	14400	409.7	25.5	0.63	0.79	0.92	389.2	28.24	0.63	0.81	0.94	367.3	31.36	0.65	0.82	0.96	343.5	34.93	0.66	0.84	0.98				
71°F	9600	404.4	25.39	0.42	0.55	0.68	385.4	28.15	0.42	0.55	0.68	363.8	31.26	0.43	0.56	0.7	339.7	34.83	0.43	0.57	0.71				
	12000	419.5	25.72	0.44	0.57	0.71	398.4	28.44	0.43	0.58	0.73	375.1	31.53	0.43	0.61	0.75	351.1	35.12	0.43	0.61	0.78				
	14400	428.8	25.92	0.44	0.62	0.77	407.6	28.66	0.44	0.62	0.79	384.2	31.77	0.45	0.64	0.81	358.5	35.33	0.45	0.66	0.83				

RATINGS

NOTE – For Temperatures and Capacities not shown in tables, see bulletin – Cooling Unit Rating Table Correction Factor Data in Miscellaneous Engineering Data section.

30 TON HIGH EFFICIENCY LCH360H4V (1 COMPRESSOR OPERATING) - VARIABLE AIR VOLUME

Entering Wet Bulb Temperature	Total Air Volume	Outdoor Air Temperature Entering Outdoor Coil																			
		65°F					75°F					85°F					95°F				
		Total Cool Cap.	Comp. Motor Input	Sensible To Total Ratio (S/T)			Total Cool Cap.	Comp. Motor Input	Sensible To Total Ratio (S/T)			Total Cool Cap.	Comp. Motor Input	Sensible To Total Ratio (S/T)			Total Cool Cap.	Comp. Motor Input	Sensible To Total Ratio (S/T)		
				Dry Bulb					Dry Bulb					Dry Bulb					Dry Bulb		
cfm	kBtuh	kW	75°F	80°F	85°F	kBtuh	kW	75°F	80°F	85°F	kBtuh	kW	75°F	80°F	85°F	kBtuh	kW	75°F	80°F	85°F	
63°F	2360	72.8	4.44	0.63	0.71	0.79	69.7	4.96	0.63	0.71	0.79	66.3	5.54	0.63	0.71	0.8	62.7	6.19	0.62	0.71	0.8
	2950	78.9	4.53	0.64	0.73	0.82	75.6	5.05	0.64	0.73	0.83	72.2	5.63	0.64	0.74	0.84	68.4	6.29	0.64	0.75	0.85
	3540	84.1	4.6	0.66	0.75	0.85	80.6	5.13	0.66	0.76	0.86	76.9	5.7	0.66	0.77	0.88	72.8	6.36	0.67	0.78	0.89
67°F	2360	76.1	4.49	0.53	0.6	0.67	72.8	5	0.52	0.6	0.67	69.5	5.59	0.51	0.6	0.68	66.1	6.25	0.5	0.59	0.68
	2950	82.8	4.58	0.53	0.61	0.7	79.5	5.1	0.52	0.62	0.7	75.9	5.68	0.52	0.62	0.71	72.1	6.35	0.52	0.62	0.71
	3540	88.3	4.66	0.54	0.63	0.72	84.8	5.19	0.54	0.63	0.73	80.9	5.77	0.54	0.64	0.74	76.7	6.43	0.53	0.64	0.75
71°F	2360	79.3	4.53	0.42	0.5	0.57	76.2	5.05	0.41	0.5	0.57	72.9	5.64	0.4	0.49	0.57	69.2	6.29	0.39	0.49	0.57
	2950	86.5	4.63	0.42	0.51	0.59	83.2	5.16	0.41	0.51	0.59	79.4	5.74	0.41	0.51	0.59	75.4	6.4	0.4	0.5	0.6
	3540	92.3	4.72	0.43	0.52	0.61	88.6	5.25	0.42	0.52	0.61	84.6	5.83	0.42	0.52	0.62	80.4	6.49	0.41	0.52	0.62

30 TON HIGH EFFICIENCY LCH360H4V (2 COMPRESSORS OPERATING) - VARIABLE AIR VOLUME

Entering Wet Bulb Temperature	Total Air Volume	Outdoor Air Temperature Entering Outdoor Coil																			
		65°F					75°F					85°F					95°F				
		Total Cool Cap.	Comp. Motor Input	Sensible To Total Ratio (S/T)			Total Cool Cap.	Comp. Motor Input	Sensible To Total Ratio (S/T)			Total Cool Cap.	Comp. Motor Input	Sensible To Total Ratio (S/T)			Total Cool Cap.	Comp. Motor Input	Sensible To Total Ratio (S/T)		
				Dry Bulb					Dry Bulb					Dry Bulb					Dry Bulb		
cfm	kBtuh	kW	75°F	80°F	85°F	kBtuh	kW	75°F	80°F	85°F	kBtuh	kW	75°F	80°F	85°F	kBtuh	kW	75°F	80°F	85°F	
63°F	4720	188.3	9.54	0.69	0.8	0.92	180.7	10.59	0.69	0.81	0.93	172.1	11.74	0.7	0.83	0.95	162.3	13.04	0.71	0.84	0.97
	5900	198.9	9.7	0.72	0.86	0.98	190.5	10.74	0.73	0.87	1	181.1	11.9	0.74	0.89	1	170.8	13.19	0.75	0.91	1
	7080	206.4	9.82	0.76	0.91	1	197.8	10.86	0.77	0.93	1	188	12.02	0.78	0.95	1	177.2	13.31	0.8	0.97	1
67°F	4720	197.6	9.68	0.56	0.67	0.77	189.7	10.73	0.56	0.67	0.78	180.7	11.89	0.56	0.68	0.8	171	13.2	0.56	0.69	0.81
	5900	208.9	9.86	0.58	0.7	0.83	200.3	10.91	0.58	0.71	0.84	190.5	12.06	0.58	0.72	0.86	180	13.36	0.59	0.73	0.88
	7080	216.8	9.99	0.6	0.74	0.88	207.9	11.03	0.6	0.75	0.9	197.6	12.19	0.61	0.76	0.92	186.6	13.48	0.61	0.78	0.94
71°F	4720	206	9.81	0.44	0.54	0.65	198.1	10.87	0.43	0.54	0.65	189	12.03	0.43	0.54	0.66	178.8	13.33	0.42	0.55	0.67
	5900	217.8	10.01	0.44	0.57	0.68	209.2	11.05	0.44	0.57	0.69	199.2	12.21	0.44	0.57	0.7	188.4	13.51	0.44	0.58	0.71
	7080	226.4	10.15	0.45	0.59	0.72	217.4	11.2	0.45	0.59	0.73	206.9	12.36	0.45	0.6	0.74	195.6	13.66	0.45	0.61	0.76

30 TON HIGH EFFICIENCY LCH360H4V (3 COMPRESSORS OPERATING) - VARIABLE AIR VOLUME

Entering Wet Bulb Temperature	Total Air Volume	Outdoor Air Temperature Entering Outdoor Coil																			
		65°F					75°F					85°F					95°F				
		Total Cool Cap.	Comp. Motor Input	Sensible To Total Ratio (S/T)			Total Cool Cap.	Comp. Motor Input	Sensible To Total Ratio (S/T)			Total Cool Cap.	Comp. Motor Input	Sensible To Total Ratio (S/T)			Total Cool Cap.	Comp. Motor Input	Sensible To Total Ratio (S/T)		
				Dry Bulb					Dry Bulb					Dry Bulb					Dry Bulb		
cfm	kBtuh	kW	75°F	80°F	85°F	kBtuh	kW	75°F	80°F	85°F	kBtuh	kW	75°F	80°F	85°F	kBtuh	kW	75°F	80°F	85°F	
63°F	7080	289.6	14.37	0.7	0.81	0.9	279.4	15.96	0.7	0.82	0.91	266.5	17.72	0.71	0.83	0.91	251.4	19.67	0.71	0.84	0.92
	8850	304.2	14.6	0.73	0.86	0.93	293.5	16.19	0.74	0.87	0.94	279.4	17.94	0.74	0.88	0.95	264.5	19.9	0.76	0.89	0.95
	10620	315.8	14.79	0.77	0.9	0.96	305.2	16.39	0.78	0.9	0.97	291.4	18.15	0.79	0.91	0.98	276	20.12	0.81	0.92	0.99
67°F	7080	305.3	14.62	0.56	0.67	0.78	295	16.22	0.56	0.67	0.79	281.3	17.97	0.56	0.68	0.8	265.9	19.93	0.56	0.69	0.82
	8850	320.2	14.87	0.58	0.71	0.84	309.1	16.46	0.59	0.71	0.85	294.5	18.21	0.59	0.72	0.86	278	20.16	0.59	0.74	0.87
	10620	330.9	15.04	0.6	0.75	0.88	319.2	16.63	0.61	0.76	0.89	303.9	18.38	0.61	0.77	0.89	286.2	20.31	0.62	0.79	0.9
71°F	7080	320.8	14.87	0.44	0.55	0.65	310	16.47	0.43	0.54	0.66	296.1	18.24	0.43	0.55	0.66	280.2	20.21	0.43	0.55	0.67
	8850	336.1	15.13	0.44	0.57	0.69	324.8	16.72	0.44	0.57	0.69	309.8	18.49	0.44	0.57	0.71	292.6	20.44	0.43	0.58	0.72
	10620	347.4	15.34	0.44	0.59	0.7	335.4	16.92	0.44	0.6	0.74	319.6	18.66	0.43	0.6	0.75	301.9	20.61	0.43	0.61	0.77

30 TON HIGH EFFICIENCY LCH360H4V (ALL COMPRESSORS OPERATING) - VARIABLE AIR VOLUME

Entering Wet Bulb Temperature	Total Air Volume	Outdoor Air Temperature Entering Outdoor Coil																			
		85°F					95°F					105°F					115°F				
		Total Cool Cap.	Comp. Motor Input	Sensible To Total Ratio (S/T)			Total Cool Cap.	Comp. Motor Input	Sensible To Total Ratio (S/T)			Total Cool Cap.	Comp. Motor Input	Sensible To Total Ratio (S/T)			Total Cool Cap.	Comp. Motor Input	Sensible To Total Ratio (S/T)		
				Dry Bulb					Dry Bulb					Dry Bulb					Dry Bulb		
cfm	kBtuh	kW	75°F	80°F	85°F	kBtuh	kW	75°F	80°F	85°F	kBtuh	kW	75°F	80°F	85°F	kBtuh	kW	75°F	80°F	85°F	
63°F	9600	366.9	24.6	0.71	0.84	0.94	350	27.35	0.72	0.85	0.95	332.2	30.52	0.74	0.87	0.97	312.1	34.14	0.76	0.89	0.99
	12000	385.3	24.99	0.76	0.89	0.99	366.8	27.74	0.78	0.91	1	347.1	30.89	0.79	0.93	1	325.6	34.48	0.81	0.95	1
	14400	398.1	25.26	0.81	0.94	1	378.9	28.01	0.83	0.96	1	358.6	31.15	0.84	0.98	1	336.4	34.78	0.86	1	1
67°F	9600	384.1	24.96	0.56	0.69	0.82	365.7	27.7	0.56	0.7	0.83	345.3	30.82	0.58	0.71	0.84	323.1	34.42	0.59	0.74	0.86
	12000	398.9	25.26	0.59	0.73	0.87	379	28	0.6	0.75	0.88	357.3	31.12	0.6	0.78	0.9	334.9	34.72	0.62	0.79	0.93
	14400	409.7	25.5	0.63	0.79	0.92	389.2	28.24	0.63	0.81	0.94	367.3	31.36	0.65	0.82	0.96	343.5	34.93	0.66	0.84	0.98
71°F	9600	404.4	25.39	0.42	0.55	0.68	385.4	28.15	0.42	0.55	0.68	363.8	31.26	0.43	0.56	0.7	339.7	34.83	0.43	0.57	0.71
	12000	419.5	25.72	0.44	0.57	0.71	398.4	28.44	0.43	0.58	0.73	375.1	31.53	0.43	0.61	0.75	351.1	35.12	0.43	0.61	0.78
	14400	428.8	25.92	0.44	0.62	0.77	407.6	28.66	0.44	0.62	0.79	384.2	31.77	0.45	0.64	0.81	358.5	35.33	0.45	0.66	0.83

HUMIDITROL® DEHUMIDIFICATION SYSTEM RATINGS

25 TON HIGH EFFICIENCY LCH300H4M WITH HUMIDITROL® OPERATING (1ST STAGE)

Entering Wet Bulb Temperature	Total Air Volume	Outdoor Air Temperature Entering Outdoor Coil																			
		65°F					75°F					85°F					95°F				
		Total Cool Cap.	Comp. Motor Input	Sensible To Total Ratio (S/T)			Total Cool Cap.	Comp. Motor Input	Sensible To Total Ratio (S/T)			Total Cool Cap.	Comp. Motor Input	Sensible To Total Ratio (S/T)			Total Cool Cap.	Comp. Motor Input	Sensible To Total Ratio (S/T)		
				Dry Bulb					Dry Bulb					Dry Bulb					Dry Bulb		
cfm	kBtuh	kW	75°F	80°F	85°F	kBtuh	kW	75°F	80°F	85°F	kBtuh	kW	75°F	80°F	85°F	kBtuh	kW	75°F	80°F	85°F	
63°F	4000	92.2	8.4	0.48	0.73	0.92	74.0	9.0	0.40	0.72	0.87	55.0	9.6	0.29	0.71	0.86	37.6	10.3	0.11	0.70	0.85
	5000	95.5	8.5	0.56	0.78	0.94	76.2	9.1	0.47	0.76	0.91	56.5	9.7	0.33	0.74	0.89	37.5	10.3	0.12	0.71	0.87
	6000	98.8	8.6	0.64	0.83	0.96	78.4	9.2	0.53	0.80	0.94	58.0	9.8	0.36	0.77	0.92	37.4	10.4	0.13	0.72	0.90
67°F	4000	102.6	8.7	0.30	0.48	0.67	83.4	9.3	0.22	0.44	0.65	63.9	9.9	0.08	0.35	0.61	44.9	10.6	-0.08	0.22	0.60
	5000	105.2	8.8	0.32	0.54	0.76	84.8	9.3	0.24	0.49	0.74	64.3	9.9	0.09	0.41	0.72	43.9	10.6	-0.09	0.23	0.70
	6000	107.8	8.9	0.34	0.60	0.85	86.2	9.5	0.26	0.55	0.83	64.7	10.1	0.10	0.46	0.81	42.9	10.6	-0.10	0.24	0.79
71°F	4000	117.8	8.9	0.13	0.31	0.49	98.8	9.6	0.07	0.21	0.42	79.7	10.2	-0.15	0.10	0.35	60.6	10.9	-0.44	0.05	0.25
	5000	119.7	9.0	0.16	0.34	0.53	99.4	9.6	0.03	0.23	0.47	79.1	10.2	-0.17	0.12	0.41	58.7	10.9	-0.51	0.06	0.30
	6000	121.5	9.1	0.18	0.37	0.56	99.9	9.7	-0.01	0.25	0.52	78.4	10.3	-0.20	0.13	0.46	56.8	10.9	-0.58	0.07	0.35

25 TON HIGH EFFICIENCY LCH300H4M WITH HUMIDITROL® OPERATING (2ND STAGE)

Entering Wet Bulb Temperature	Total Air Volume	Outdoor Air Temperature Entering Outdoor Coil																			
		65°F					75°F					85°F					95°F				
		Total Cool Cap.	Comp. Motor Input	Sensible To Total Ratio (S/T)			Total Cool Cap.	Comp. Motor Input	Sensible To Total Ratio (S/T)			Total Cool Cap.	Comp. Motor Input	Sensible To Total Ratio (S/T)			Total Cool Cap.	Comp. Motor Input	Sensible To Total Ratio (S/T)		
				Dry Bulb					Dry Bulb					Dry Bulb					Dry Bulb		
cfm	kBtuh	kW	75°F	80°F	85°F	kBtuh	kW	75°F	80°F	85°F	kBtuh	kW	75°F	80°F	85°F	kBtuh	kW	75°F	80°F	85°F	
63°F	8000	240.9	15.5	0.61	0.82	0.91	214.1	17.0	0.59	0.79	0.90	187.3	18.5	0.56	0.77	0.89	160.5	20.0	0.53	0.74	0.88
	10000	257.1	15.8	0.65	0.85	0.94	224.8	17.2	0.64	0.84	0.94	192.2	18.7	0.63	0.83	0.95	160.3	20.1	0.62	0.82	0.94
	12000	273.3	16.1	0.68	0.88	0.97	235.4	17.4	0.69	0.89	0.99	197.0	18.8	0.71	0.89	1.00	160.2	20.2	0.72	0.90	1.00
67°F	8000	272.1	16.0	0.45	0.56	0.75	242.0	17.5	0.41	0.55	0.73	212.2	19.0	0.37	0.54	0.71	181.9	20.5	0.32	0.51	0.69
	10000	286.7	16.2	0.47	0.62	0.78	251.6	17.6	0.44	0.61	0.78	216.5	19.0	0.41	0.60	0.77	181.4	20.4	0.38	0.58	0.76
	12000	301.3	16.5	0.49	0.68	0.82	261.3	17.8	0.47	0.67	0.83	220.8	19.2	0.45	0.66	0.83	180.9	20.5	0.43	0.65	0.83
71°F	8000	284.6	16.5	0.28	0.43	0.58	257.7	18.0	0.23	0.39	0.55	230.9	19.5	0.17	0.35	0.52	204.0	21.0	0.11	0.30	0.49
	10000	297.6	16.7	0.29	0.46	0.63	266.4	18.1	0.24	0.42	0.61	234.6	19.5	0.19	0.39	0.59	203.2	20.9	0.13	0.35	0.57
	12000	310.5	16.8	0.30	0.49	0.67	275.0	18.2	0.25	0.46	0.67	238.3	19.5	0.20	0.43	0.66	202.3	20.9	0.14	0.40	0.65

30 TON HIGH EFFICIENCY LCH360H4M WITH HUMIDITROL® OPERATING (1ST STAGE)

Entering Wet Bulb Temperature	Total Air Volume	Outdoor Air Temperature Entering Outdoor Coil																			
		65°F					75°F					85°F					95°F				
		Total Cool Cap.	Comp. Motor Input	Sensible To Total Ratio (S/T)			Total Cool Cap.	Comp. Motor Input	Sensible To Total Ratio (S/T)			Total Cool Cap.	Comp. Motor Input	Sensible To Total Ratio (S/T)			Total Cool Cap.	Comp. Motor Input	Sensible To Total Ratio (S/T)		
				Dry Bulb					Dry Bulb					Dry Bulb					Dry Bulb		
cfm	kBtuh	kW	75°F	80°F	85°F	kBtuh	kW	75°F	80°F	85°F	kBtuh	kW	75°F	80°F	85°F	kBtuh	kW	75°F	80°F	85°F	
63°F	4800	102.0	11.0	0.47	0.72	0.95	82.1	11.8	0.37	0.68	0.93	62.2	12.6	0.26	0.64	0.92	42.3	13.4	0.14	0.57	0.91
	6000	103.4	11.1	0.58	0.77	0.97	82.9	11.8	0.44	0.73	0.96	62.4	12.6	0.29	0.70	0.95	41.9	13.4	0.03	0.63	0.96
	7200	104.8	11.1	0.68	0.83	0.98	83.7	11.9	0.50	0.79	0.98	62.6	12.6	0.31	0.75	0.97	41.4	13.3	-0.07	0.68	1.00
67°F	4800	113.7	11.4	0.28	0.47	0.66	92.2	12.1	0.21	0.42	0.64	72.4	12.9	0.10	0.36	0.62	51.7	13.8	-0.03	0.28	0.60
	6000	115.3	11.5	0.32	0.51	0.71	94.0	12.2	0.23	0.46	0.69	72.0	12.9	0.13	0.40	0.67	50.2	13.8	-0.05	0.30	0.66
	7200	116.2	11.6	0.35	0.56	0.77	94.7	12.3	0.25	0.50	0.76	71.9	12.9	0.15	0.45	0.75	49.0	13.8	-0.10	0.32	0.73
71°F	4800	123.3	11.7	0.10	0.23	0.37	102.3	12.3	0.04	0.19	0.33	82.5	13.2	-0.02	0.14	0.30	61.0	13.9	-0.25	0.05	0.29
	6000	126.7	11.8	0.11	0.28	0.46	104.0	12.4	0.03	0.22	0.42	81.8	13.3	-0.06	0.16	0.38	58.8	14.0	-0.31	0.07	0.37
	7200	130	11.9	0.12	0.33	0.55	105.6	12.6	0.01	0.26	0.51	81.1	13.3	-0.10	0.19	0.48	56.5	14.0	-0.51	0.07	0.46

30 TON HIGH EFFICIENCY LCH360H4M WITH HUMIDITROL® OPERATING (2ND STAGE)

Entering Wet Bulb Temperature	Total Air Volume	Outdoor Air Temperature Entering Outdoor Coil																			
		65°F					75°F					85°F					95°F				
		Total Cool Cap.	Comp. Motor Input	Sensible To Total Ratio (S/T)			Total Cool Cap.	Comp. Motor Input	Sensible To Total Ratio (S/T)			Total Cool Cap.	Comp. Motor Input	Sensible To Total Ratio (S/T)			Total Cool Cap.	Comp. Motor Input	Sensible To Total Ratio (S/T)		
				Dry Bulb					Dry Bulb					Dry Bulb					Dry Bulb		
cfm	kBtuh	kW	75°F	80°F	85°F	kBtuh	kW	75°F	80°F	85°F	kBtuh	kW	75°F	80°F	85°F	kBtuh	kW	75°F	80°F	85°F	
63°F	9600	286.4	20.3	0.60	0.80	0.89	254.8	22.2	0.59	0.79	0.88	223.2	24.1	0.57	0.77	0.87	191.6	25.9	0.55	0.74	0.86
	12,000	298.4	20.6	0.65	0.85	0.93	263.3	22.4	0.64	0.84	0.93	228.2	24.2	0.63	0.83	0.94	193.1	26.0	0.63	0.82	0.94
	14,400	310.4	20.9	0.70	0.90	0.97	271.8	22.6	0.69	0.89	0.98	233.2	24.4	0.69	0.89	1.00	194.6	26.1	0.70	0.89	1.00
67°F	9600	307.4	20.7	0.43	0.57	0.71	274.5	22.6	0.40	0.55	0.74	241.6	24.5	0.36	0.53	0.74	208.8	26.4	0.31	0.52	0.73
	12,000	322.1	20.9	0.50	0.64	0.78	284.7	22.8	0.45	0.63	0.79	247.3	24.7	0.41	0.61	0.81	209.9	26.6	0.37	0.60	0.83
	14,400	336.8	21.0	0.57	0.71	0.85	294.9	23.0	0.49	0.67	0.84	253.0	24.9	0.46	0.67	0.88	211.0	26.8	0.43	0.68	0.93
71°F	9600	337.5	21.2	0.27	0.42	0.56	302.7	23.1	0.22	0.39	0.55	266.8	25.0	0.18	0.36	0.54	231.4	26.9	0.12	0.33	0.53
	12,000	349.9	21.7	0.31	0.47	0.62	310.0	23.4	0.24	0.43	0.61	270.1	25.2	0.19	0.40	0.60	230.2	27.0	0.12	0.36	0.59
	14,400	362.3	22.1	0.35	0.52	0.68	317.3	23.8	0.26	0.47	0.67	273.4	25.4	0.20	0.43	0.66	229.0	27.1	0.12	0.39	0.65

BLOWER DATA

BLOWER TABLE INCLUDES RESISTANCE FOR BASE UNIT ONLY WITH DRY INDOOR COIL & AIR FILTERS IN PLACE FOR ALL UNITS ADD:

- 1 - Wet indoor coil air resistance of selected unit.
- 2 - Any factory installed options air resistance (electric heat, economizer, etc.)
- 3 - Any field installed accessories air resistance (electric heat, duct resistance, diffuser, etc.)

Then determine from blower table blower motor output and drive required.

See page 36 for wet coil and option/accessory air resistance data.

See page 36 for factory installed drive kit specifications.

MINIMUM AIR VOLUME REQUIRED FOR USE WITH OPTIONAL ELECTRIC HEAT

All units require 10,500 cfm minimum air with electric heat.

Air Volume cfm	TOTAL STATIC PRESSURE - In. w.g.																																																																																																																																																																																																																																																																																																																																																																																																																																																																																																																																																																																																																																																																																																																																																																																																																																																																																																																																																																																																																																																																																																																																																																								
	0.20		0.40		0.60		0.80		1.00		1.20		1.40		1.60		1.80		2.00		2.20		2.40		2.60																																																																																																																																																																																																																																																																																																																																																																																																																																																																																																																																																																																																																																																																																																																																																																																																																																																																																																																																																																																																																																																																																																																																																
	RPM	BHP	RPM	BHP	RPM	BHP	RPM	BHP	RPM	BHP	RPM	BHP	RPM	BHP	RPM	BHP	RPM	BHP	RPM	BHP	RPM	BHP	RPM	BHP	RPM	BHP	RPM	BHP																																																																																																																																																																																																																																																																																																																																																																																																																																																																																																																																																																																																																																																																																																																																																																																																																																																																																																																																																																																																																																																																																																																																													
4000	372	0.26	433	0.65	497	0.99	565	1.27	630	1.54	687	1.79	738	2.04	784	2.30	824	2.56	861	2.82	897	3.10	932	3.40	968	3.66	1001	3.92	1028	4.18	1055	4.44	1082	4.70	1109	4.96	1136	5.22	1163	5.48	1190	5.74	1217	6.00	1244	6.26	1271	6.52	1298	6.78	1325	7.04	1352	7.30	1379	7.56	1406	7.82	1433	8.08	1460	8.34	1487	8.60	1514	8.86	1541	9.12	1568	9.38	1595	9.64	1622	9.90	1649	10.16	1676	10.42	1703	10.68	1730	10.94	1757	11.20	1784	11.46	1811	11.72	1838	11.98	1865	12.24	1892	12.50	1919	12.76	1946	13.02	1973	13.28	2000	13.54	2027	13.80	2104	14.32	2181	14.84	2258	15.36	2335	15.88	2412	16.40	2489	16.92	2566	17.44	2643	17.96	2720	18.48	2797	19.00	2874	19.52	2951	20.04	3028	20.56	3105	21.08	3182	21.60	3259	22.12	3336	22.64	3413	23.16	3490	23.68	3567	24.20	3644	24.72	3721	25.24	3798	25.76	3875	26.28	3952	26.80	4029	27.32	4106	27.84	4183	28.36	4260	28.88	4337	29.40	4414	29.92	4491	30.44	4568	30.96	4645	31.48	4722	32.00	4799	32.52	4876	33.04	4953	33.56	5030	34.08	5107	34.60	5184	35.12	5261	35.64	5338	36.16	5415	36.68	5492	37.20	5569	37.72	5646	38.24	5723	38.76	5800	39.28	5877	39.80	5954	40.32	6031	40.84	6108	41.36	6185	41.88	6262	42.40	6339	42.92	6416	43.44	6493	43.96	6570	44.48	6647	45.00	6724	45.52	6801	46.04	6878	46.56	6955	47.08	7032	47.60	7109	48.12	7186	48.64	7263	49.16	7340	49.68	7417	50.20	7494	50.72	7571	51.24	7648	51.76	7725	52.28	7802	52.80	7879	53.32	7956	53.84	8033	54.36	8110	54.88	8187	55.40	8264	55.92	8341	56.44	8418	56.96	8495	57.48	8572	58.00	8649	58.52	8726	59.04	8803	59.56	8880	60.08	8957	60.60	9034	61.12	9111	61.64	9188	62.16	9265	62.68	9342	63.20	9419	63.72	9496	64.24	9573	64.76	9650	65.28	9727	65.80	9804	66.32	9881	66.84	9958	67.36	10035	67.88	10112	68.40	10189	68.92	10266	69.44	10343	69.96	10420	70.48	10497	71.00	10574	71.52	10651	72.04	10728	72.56	10805	73.08	10882	73.60	10959	74.12	11036	74.64	11113	75.16	11190	75.68	11267	76.20	11344	76.72	11421	77.24	11498	77.76	11575	78.28	11652	78.80	11729	79.32	11806	79.84	11883	80.36	11960	80.88	12037	81.40	12114	81.92	12191	82.44	12268	82.96	12345	83.48	12422	84.00	12499	84.52	12576	85.04	12653	85.56	12730	86.08	12807	86.60	12884	87.12	12961	87.64	13038	88.16	13115	88.68	13192	89.20	13269	89.72	13346	90.24	13423	90.76	13500	91.28	13577	91.80	13654	92.32	13731	92.84	13808	93.36	13885	93.88	13962	94.40	14039	94.92	14116	95.44	14193	95.96	14270	96.48	14347	97.00	14424	97.52	14501	98.04	14578	98.56	14655	99.08	14732	99.60	14809	100.12	14886	100.64	14963	101.16	15040	101.68	15117	102.20	15194	102.72	15271	103.24	15348	103.76	15425	104.28	15502	104.80	15579	105.32	15656	105.84	15733	106.36	15810	106.88	15887	107.40	15964	107.92	16041	108.44	16118	108.96	16195	109.48	16272	110.00	16349	110.52	16426	111.04	16503	111.56	16580	112.08	16657	112.60	16734	113.12	16811	113.64	16888	114.16	16965	114.68	17042	115.20	17119	115.72	17196	116.24	17273	116.76	17350	117.28	17427	117.80	17504	118.32	17581	118.84	17658	119.36	17735	119.88	17812	120.40	17889	120.92	17966	121.44	18043	121.96	18120	122.48	18197	123.00	18274	123.52	18351	124.04	18428	124.56	18505	125.08	18582	125.60	18659	126.12	18736	126.64	18813	127.16	18890	127.68	18967	128.20	19044	128.72	19121	129.24	19198	129.76	19275	130.28	19352	130.80	19429	131.32	19506	131.84	19583	132.36	19660	132.88	19737	133.40	19814	133.92	19891	134.44	19968	134.96	20045	135.48	20122	136.00	20199	136.52	20276	137.04	20353	137.56	20430	138.08	20507	138.60	20584	139.12	20661	139.64	20738	140.16	20815	140.68	20892	141.20	20969	141.72	21046	142.24	21123	142.76	21200	143.28	21277	143.80	21354	144.32	21431	144.84	21508	145.36	21585	145.88	21662	146.40	21739	146.92	21816	147.44	21893	147.96	21970	148.48	22047	149.00	22124	149.52	22201	150.04	22278	150.56	22355	151.08	22432	151.60	22509	152.12	22586	152.64	22663	153.16	22740	153.68	22817	154.20	22894	154.72	22971	155.24	23048	155.76	23125	156.28	23202	156.80	23279	157.32	23356	157.84	23433	158.36	23510	158.88	23587	159.40	23664	159.92	23741	160.44	23818	160.96	23895	161.48	23972	162.00	24049	162.52	24126	163.04	24203	163.56	24280	164.08	24357	164.60	24434	165.12	24511	165.64	24588	166.16	24665	166.68	24742	167.20	24819	167.72	24896	168.24	24973	168.76	25050	169.28	25127	169.80	25204	170.32	25281	170.84	25358	171.36	25435	171.88	25512	172.40	25589	172.92	25666	173.44	25743	173.96	25820	174.48	25897	175.00	25974	175.52	26051	176.04	26128	176.56	26205	177.08	26282	177.60	26359	178.12	26436	178.64	26513	179.16	26590	179.68	26667	180.20	26744	180.72	26821	181.24	26898	181.76	26975	182.28	27052	182.80	27129	183.32	27206	183.84	27283	184.36	27360	184.88	27437	185.40	27514	185.92	27591	186.44	27668	186.96	27745	187.48	27822	188.00	27899	188.52	27976	189.04	28053	189.56	28130	190.08	28207	190.60	28284	191.12	28361	191.64	28438	192.16	28515	192.68	28592	193.20	28669	193.72	28746	194.24	28823	194.76	28900	195.28	28977	195.80	29054	196.32	29131	196.84	29208	197.36	29285	197.88	29362	198.40	29439	198.92	29516	199.44	29593	199.96	29670	200.48	29747	201.00	29784	201.52	29821	202.04	29858	202.56	29895	203.08	29932	203.60	29969	204.12	30006	204.64	30043	205.16	30080	205.68	30117	206.20	30154	206.72	30191	207.24	30228	207.76	30265	208.28	30302	208.80	30339	209.32	30376	209.84	30413	210.36	30450	210.88	30487	211.40	30524	211.92	30561	212.44	30598	212.96	30635	213.48	30672	214.00	30709	214.52	30746	215.04	30783	215.56	30820	216.08	30857	216.60	30894	217.12	30931	217.64	30968	218.16	31005	218.68	31042	219.20	31079	219.72	31116	220.24	31153	220.76	31190	221.28	31227	221.80	31264	222.32	31301	222.84	31338	223.36	31375	223.88	31412	224.40	31449	224.92	31486	225.44	31523	225.96	31560	226.48	31597	227.00	31634	227.52	31671	228.04	31708	228.56	31745	229.08	31782	229.60	31819	230.12	31856	230.64	31893	231.16	31930	231.68	31967	232.20	32004	232.72	32041	233.24	32078	233.76	32115	234.28	32152	234.80	32189	235.32	32226	235.84	32263	236.36	32300	236.88	32337	237.40	32374	237.92	32411	238.44	32448	238.96	32485	239.48	32522	240.00	32559	240.52	32596	241.04	32633	241.56	32670	242.08	32707	242.60	32744	243.12	32781	243.64	32818	244.16	32855	244.68	32892	245.20	32929	245.72	32966	246.24	33003	246.76	33040	247.28	33077	247.80	33114	248.32	33151	248.84	33188	249.36	33225	249.88	33262	250.40	33299	250.92	33336	251.44	33373	251.96	33410	252.48	33447	253.00	33484	253.52	33521	254.04	33558	254.56	33595	255.08	33632	255.60	33669	256.12	33706	256.64	33743	257.16	33780	257.68	33817	258.20	33854	258.72	33891	259.24	33928	259.76	33965	260.28	34002	260.80	34039	261.32	34076	261.84	34113	262.36	34150	262.88	34187	263.40	34224	263.92	34261	264.44	34298	264.96	34335	265.48	34372	266.00	34409	266.52	34446	267.04	34483	267.56	34520	268.08	34557	268.60	34594	269.12	34631	269.64	34668	270.16	34705	270.68	34742	271.20	34779	271.72	34816	272.24	34853	272.76	34890	273.28	34927	273.80	34964	274.32	35001	274.84	35038	275.36	35075	275.88	35112	276.40	35149	276.92	35186	277.44	35223	277.96	35260	278.48	35297	279.00	35334	279.52	35371	280.04	35

BLOWER DATA

DRIVE KIT SPECIFICATIONS

Motor Efficiency	Nominal hp	Maximum hp	Drive Kit Number	RPM Range
Standard	5	5.75	5	660 - 810
Standard	5	5.75	6	770 - 965
Standard	5	5.75	7	570 - 720
Standard	5	5.75	8	480 - 630
Standard	5	5.75	9	410 - 535
Standard	7.5	8.63	3	715 - 880
Standard	7.5	8.63	4	770 - 965
Standard	10	11.50	1	740 - 895
Standard	10	11.50	2	870 - 1045

NOTES

Using total air volume and system static pressure requirements determine from blower performance tables rpm and motor output required. Maximum usable output of motors furnished are shown. In Canada, nominal motor output is also maximum usable motor output. If motors of comparable output are used, be sure to keep within the service factor limitations outlined on the motor nameplate.

For VFD applications, nominal motor output is also maximum usable motor output.

FACTORY INSTALLED OPTIONS/FIELD INSTALLED ACCESSORY AIR RESISTANCE

Air Volume cfm	Wet Indoor Coil in. w.g.	Humiditrol® Condenser Reheat Coil in. w.g.	Electric Heat in. w.g.	Economizer in. w.g.	Filters		Horizontal Roof Curb in. w.g.
					MERV 8 in. w.g.	MERV 13 in. w.g.	
4000	0.04	0.04	0.01	0.00	0.00	0.00	0.04
4500	0.04	0.04	0.01	0.00	0.00	0.00	0.05
5000	0.05	0.04	0.01	0.00	0.00	0.00	0.06
5500	0.06	0.06	0.02	0.01	0.00	0.01	0.07
6000	0.07	0.06	0.02	0.01	0.00	0.02	0.08
6500	0.08	0.08	0.02	0.01	0.01	0.02	0.09
7000	0.09	0.08	0.03	0.02	0.01	0.03	0.10
7500	0.10	0.10	0.03	0.02	0.01	0.04	0.11
8000	0.11	0.10	0.03	0.02	0.01	0.04	0.13
8500	0.12	0.10	0.04	0.03	0.01	0.04	0.15
9000	0.13	0.12	0.04	0.04	0.01	0.04	0.17
9500	0.14	0.14	0.05	0.04	0.02	0.06	0.19
10,000	0.15	0.16	0.05	0.05	0.02	0.06	0.21
10,500	0.16	0.17	0.06	0.06	0.02	0.06	0.24
11,000	0.18	0.18	0.06	0.07	0.02	0.07	0.27
11,500	0.19	0.19	0.07	0.08	0.02	0.08	0.30
12,000	0.20	0.20	0.07	0.10	0.02	0.08	0.33
12,500	0.21	0.22	0.08	0.11	0.03	0.10	0.37
13,000	0.23	0.23	0.08	0.13	0.03	0.10	0.40
13,500	0.24	0.25	0.09	0.14	0.03	0.11	0.44
14,000	0.26	0.26	0.10	0.16	0.03	0.12	0.49
14,500	0.27	0.27	0.10	0.18	0.04	0.13	0.53
15,000	0.29	0.29	0.11	0.21	0.04	0.13	0.58

BLOWER DATA

POWER EXHAUST PERFORMANCE - STANDARD STATIC

Return Duct Negative Static Pressure	Air Volume Exhausted
in. w.g.	cfm
0.00	12,800
0.05	12,200
0.10	11,500
0.15	10,800
0.20	9900
0.25	9000
0.30	7900
0.35	6750
0.40	5450
0.45	4150
0.50	2900

POWER EXHAUST - 50% HIGH STATIC OPERATION

Air Volume cfm	RETURN DUCT NEGATIVE STATIC PRESSURE - In. w.g.																					
	0		0.10		0.20		0.30		0.40		0.50		0.60		0.70		0.80		0.90		1.0	
	RPM	BHP	RPM	BHP	RPM	BHP	RPM	BHP	RPM	BHP	RPM	BHP	RPM	BHP	RPM	BHP	RPM	BHP	RPM	BHP	RPM	BHP
4000	---	---	---	---	430	0.40	475	0.45	520	0.50	570	0.55	615	0.65	665	0.70	710	0.75	755	0.85	---	---
4500	---	---	415	0.45	460	0.55	500	0.60	545	0.65	585	0.70	625	0.80	670	0.85	710	0.95	750	1.00	795	1.10
5000	415	0.55	455	0.65	490	0.70	530	0.75	570	0.85	605	0.90	645	1.00	680	1.05	720	1.15	755	1.20	795	1.30
5500	460	0.75	495	0.85	525	0.90	560	0.95	595	1.05	630	1.10	665	1.20	700	1.30	735	1.35	765	1.45	800	1.55
6000	500	1.00	530	1.05	565	1.15	595	1.20	625	1.30	660	1.40	690	1.45	720	1.55	750	1.65	785	1.70	815	1.80
6500	540	1.25	570	1.30	600	1.40	630	1.50	660	1.60	685	1.65	715	1.75	745	1.85	775	1.95	805	2.05	830	2.10
7000	585	1.55	610	1.65	635	1.70	665	1.85	690	1.90	720	2.00	745	2.10	770	2.20	800	2.30	825	2.40	855	2.50
7500	625	1.90	650	2.00	675	2.10	700	2.20	725	2.30	750	2.40	775	2.50	800	2.60	825	2.70	850	2.80	875	2.90
8000	665	2.30	690	2.40	715	2.55	735	2.60	760	2.70	785	2.85	810	2.95	830	3.05	855	3.15	880	3.25	905	3.40
8500	710	2.80	730	2.90	755	3.00	775	3.10	795	3.20	820	3.35	840	3.45	865	3.55	885	3.65	910	3.80	930	3.90

POWER EXHAUST - 100% HIGH STATIC OPERATION

Air Volume cfm	RETURN DUCT NEGATIVE STATIC PRESSURE - In. w.g.																					
	0		0.10		0.20		0.30		0.40		0.50		0.60		0.70		0.80		0.90		1.0	
	RPM	BHP	RPM	BHP	RPM	BHP	RPM	BHP	RPM	BHP	RPM	BHP	RPM	BHP	RPM	BHP	RPM	BHP	RPM	BHP	RPM	BHP
8500	475	1.30	500	1.30	525	1.40	550	1.50	585	1.60	625	1.75	670	1.90	710	2.10	745	2.30	780	2.50	815	2.70
9000	520	1.55	535	1.60	550	1.65	570	1.70	605	1.85	640	1.95	685	2.15	720	2.35	760	2.55	790	2.75	825	3.00
9500	550	1.80	560	1.85	575	1.90	600	2.00	620	2.10	655	2.20	695	2.40	735	2.60	770	2.80	800	3.00	835	3.25
10,000	575	2.10	590	2.15	605	2.20	620	2.30	645	2.40	675	2.50	710	2.65	745	2.85	780	3.05	815	3.30	845	3.50
10,500	605	2.45	615	2.45	625	2.50	645	2.60	670	2.75	690	2.80	725	3.00	755	3.15	790	3.35	825	3.60	855	3.80
11,000	630	2.80	645	2.85	660	2.95	675	3.00	685	3.05	715	3.20	740	3.30	770	3.50	805	3.70	835	3.90	870	4.20
11,500	665	3.25	675	3.30	680	3.30	695	3.40	715	3.50	735	3.60	755	3.70	785	3.85	815	4.05	850	4.30	880	4.50
12,000	685	3.60	700	3.70	710	3.75	725	3.85	740	3.95	755	4.00	780	4.15	805	4.30	830	4.45	860	4.65	890	4.90
12,500	720	4.10	730	4.20	740	4.25	750	4.30	765	4.40	780	4.50	800	4.60	820	4.75	845	4.90	875	5.10	905	5.35
13,000	745	4.60	750	4.65	765	4.75	780	4.85	790	4.90	805	5.00	820	5.10	840	5.25	865	5.40	890	5.60	915	5.80
13,500	775	5.15	785	5.25	795	5.35	805	5.40	815	5.50	830	5.60	845	5.70	865	5.80	880	5.95	905	6.10	930	6.30
14,000	805	5.80	810	5.80	820	5.90	830	6.00	845	6.10	855	6.20	870	6.30	885	6.40	905	6.55	925	6.70	---	---

HIGH STATIC POWER EXHAUST WITH CONSTANT AIR VOLUME – DRIVE KIT SPECIFICATIONS

Power Exhaust Model No.	Motor HP	Drive Kit Number	RPM Range
LAPEB30/36A (50%)	(2) 2 hp	1	406 - 533
LAPEB30/36B (50%)	(2) 2 hp	2	531 - 731
LAPEB30/36C (50%)	(2) 2 hp	3	731 - 932
LAPEB30/36D (100%)	(3) 2 hp	1	406 - 533
LAPEB30/36E (100%)	(3) 2 hp	2	531 - 731
LAPEB30/36F (100%)	(3) 2 hp	3	731 - 932

NOTE – Using total air volume and system static pressure requirements, determine from blower performance tables rpm and motor output required.

BLOWER DATA

CEILING DIFFUSER AIR RESISTANCE - in. w.g.

Air Volume cfm	Step-Down Diffuser			Flush Diffuser
	LARTD30/36S			LAFD30/36S
	2 Ends Open	1 Side/2 Ends Open	All Ends & Sides Open	
7500	0.37	0.31	0.25	0.29
8000	0.42	0.36	0.29	0.34
8500	0.48	0.41	0.34	0.39
9000	0.55	0.47	0.39	0.44
9500	0.62	0.53	0.45	0.51
10,000	0.70	0.60	0.51	0.57
10,500	0.78	0.68	0.58	0.65
11,000	0.87	0.76	0.65	0.72
11,500	0.97	0.85	0.73	0.81
12,000	1.08	0.94	0.82	0.9
12,500	1.19	1.04	0.91	0.99
13,000	1.30	1.15	1.00	1.10
13,500	1.43	1.26	1.10	1.20
14,000	1.56	1.38	1.20	1.31
14,500	1.69	1.50	1.31	1.43
15,000	1.84	1.63	1.43	1.56

CEILING DIFFUSER AIR THROW DATA - ft.

Air Volume cfm	¹ Effective Throw Range - ft.	
	Step-Down	Flush
9000	40 - 47	29 - 35
9500	43 - 50	33 - 41
10,000	46 - 54	37 - 46
10,500	50 - 58	42 - 51
11,000	53 - 61	46 - 56
11,500	55 - 64	50 - 61
12,000	58 - 67	54 - 66
12,500	61 - 71	58 - 71
13,000	64 - 74	62 - 75
13,500	67 - 77	66 - 79

¹ Throw is the horizontal or vertical distance an airstream travels on leaving the outlet or diffuser before the maximum velocity is reduced to 50 ft. per minute. Four sides open.

ELECTRICAL DATA

HIGH EFFICIENCY - VARIABLE AIR VOLUME - 20 TON

Model No.		LCH242H4V								
		208/230V - 3 Ph			460V - 3 Ph			575V - 3 Ph		
¹ Voltage - 60hz										
Compressor 1	Rated Load Amps	13.5			8			5		
	Locked Rotor Amps	109			59			40		
Compressor 2	Rated Load Amps	13.5			8			5		
	Locked Rotor Amps	109			59			40		
Compressor 3	Rated Load Amps	13.5			8			5		
	Locked Rotor Amps	109			59			40		
Compressor 4	Rated Load Amps	13.5			8			5		
	Locked Rotor Amps	109			59			40		
Outdoor Fan Motors (6)	Full Load Amps	2.4			1.3			1		
	(total)	(14.4)			(7.8)			(6)		
Standard Power Exhaust (3) 0.33 HP	Full Load Amps	2.4			1.3			1		
	(total)	(7.2)			(3.9)			(3)		
50% High Static Power Exhaust (2) 2 HP	Full Load Amps	7.5			3.4			2.7		
	(total)	(15)			(6.8)			(5.4)		
100% High Static Power Exhaust (3) 2 HP	Full Load Amps	7.5			3.4			2.7		
	(total)	(22.5)			(10.2)			(8.1)		
Service Outlet 115V GFI (amps)		15			15			20		
Indoor Blower Motor	Horsepower	5	7.5	10	5	7.5	10	5	7.5	10
	Full Load Amps	16.7	24.2	30.8	7.6	11	14	6.1	9	11
² Maximum Overcurrent Protection	Unit Only	100	110	125	50	60	70	35	45	50
	With (3) 0.33 HP Standard Power Exhaust	110	125	125	60	60	70	40	45	50
	With 50% High Static Power Exhaust (2) 2 HP	110	125	150	60	70	70	45	50	50
	With 100% High Static Power Exhaust (3) 2 HP	125	125	150	60	70	80	45	50	50
³ Minimum Circuit Ampacity	Unit Only	90	99	107	50	54	58	34	38	40
	With (3) 0.33 HP Standard Power Exhaust	97	106	115	54	58	62	37	41	43
	With 50% High Static Power Exhaust (2) 2 HP	105	114	122	57	61	65	40	43	46
	With 100% High Static Power Exhaust (3) 2 HP	112	122	130	60	64	68	42	46	48

NOTE - All units have a minimum Short Circuit Current Rating (SCCR) of 5000 amps.

¹ Extremes of operating range are plus and minus 10% of line voltage.

² HACR type breaker or fuse.

³ Refer to National or Canadian Electrical Code manual to determine wire, fuse and disconnect size requirements.

ELECTRIC HEAT DATA

HIGH EFFICIENCY - VARIABLE AIR VOLUME - 20 TON

Model No.		LCH242H4V												
¹ Voltage - 60hz - 3 phase		208/230V - 3 Ph						460V - 3 Ph			575V - 3 Ph			
Indoor Blower Motor	Horsepower	5		7.5		10		5	7.5	10	5	7.5	10	
Electric Heat Voltage		208V	240V	208V	240V	208V	240V	480V	480V	480V	600V	600V	600V	
² Maximum Overcurrent Protection	Unit+ Electric Heat	30 kW	⁴ 100	125	⁴ 110	125	⁴ 125	150	60	60	70	45	50	50
		45 kW	⁴ 150	175	⁴ 150	175	175	175	80	90	90	70	70	70
		60 kW	⁴ 150	175	175	175	⁴ 175	200	90	90	90	70	70	80
		90 kW	⁴ 225	250	⁴ 225	250	⁴ 250	⁴ 300	125	125	150	100	100	110
		120 kW	⁴ 300	⁴ 350	⁴ 300	⁴ 350	⁴ 300	⁴ 350	175	175	175	125	150	150
	Unit+ Electric Heat and Standard Power Exhaust (3) 0.33 HP	30 kW	⁴ 110	125	⁴ 125	150	150	150	60	70	70	50	60	60
		45 kW	⁴ 150	175	175	175	⁴ 175	200	90	90	100	70	70	80
		60 kW	175	175	⁴ 175	200	⁴ 175	200	90	100	100	70	80	80
		90 kW	⁴ 225	250	⁴ 250	⁴ 300	⁴ 250	⁴ 300	125	150	150	100	110	110
		120 kW	⁴ 300	⁴ 350	⁴ 300	⁴ 350	⁴ 300	⁴ 350	175	175	175	150	150	150
	Unit+ Electric Heat and 50% High Static Power Exhaust (2) 2 HP	30 kW	⁴ 125	150	150	150	150	150	70	70	80	60	60	60
		45 kW	175	175	⁴ 175	200	⁴ 175	200	90	90	100	70	80	80
		60 kW	⁴ 175	200	⁴ 175	200	⁴ 200	225	100	100	100	80	80	80
		90 kW	⁴ 250	⁴ 300	⁴ 250	⁴ 300	⁴ 250	⁴ 300	150	150	150	110	110	110
		120 kW	⁴ 300	⁴ 350	⁴ 300	⁴ 350	350	⁴ 350	175	175	175	150	150	150
	Unit+ Electric Heat and 100% High Static Power Exhaust (3) 2 HP	30 kW	150	150	150	150	⁴ 150	175	70	80	80	60	60	60
		45 kW	⁴ 175	200	200	200	⁴ 200	225	90	100	100	80	80	80
		60 kW	⁴ 175	200	⁴ 200	225	⁴ 200	225	100	100	110	80	80	90
		90 kW	⁴ 250	⁴ 300	⁴ 250	⁴ 300	300	⁴ 300	150	150	150	110	110	125
		120 kW	⁴ 300	⁴ 350	350	⁴ 350	⁴ 350	⁴ 400	175	175	175	150	150	150
³ Minimum Circuit Ampacity	Unit+ Electric Heat	30 kW	100	112	109	121	117	129	55	59	63	44	48	50
		45 kW	139	157	148	166	156	174	78	82	86	62	66	68
		60 kW	146	166	156	175	164	183	82	86	90	66	69	72
		90 kW	209	238	218	247	227	256	118	123	126	95	98	101
		120 kW	272	310	281	319	289	328	154	159	162	124	127	130
	Unit+ Electric Heat and Standard Power Exhaust (3) 0.33 HP	30 kW	109	121	118	130	126	138	60	64	68	48	52	54
		45 kW	148	166	157	175	165	183	83	87	91	66	70	72
		60 kW	155	175	165	184	173	192	87	91	95	70	73	76
		90 kW	218	247	227	256	236	265	123	127	131	98	102	105
		120 kW	281	319	290	328	298	337	159	163	167	127	131	133
	Unit+ Electric Heat and 50% High Static Power Exhaust (2) 2 HP	30 kW	118	130	128	140	136	148	64	68	72	51	55	57
		45 kW	157	175	167	185	175	193	86	90	94	69	73	75
		60 kW	165	184	175	194	183	202	91	95	99	73	76	79
		90 kW	228	257	237	266	245	274	127	131	135	101	105	108
		120 kW	290	329	300	338	308	346	163	167	171	130	134	136
	Unit+ Electric Heat and 100% High Static Power Exhaust (3) 2 HP	30 kW	128	140	137	149	145	157	68	72	76	54	58	60
		45 kW	167	185	176	194	184	202	90	95	98	72	76	79
		60 kW	175	194	184	203	192	211	95	99	103	76	80	82
		90 kW	237	266	247	275	255	284	131	135	139	105	108	111
		120 kW	300	338	309	348	317	356	167	171	175	134	137	140

¹ Extremes of operating range are plus and minus 10% of line voltage.

² HACR type breaker or fuse.

³ Refer to National or Canadian Electrical Code manual to determine wire, fuse and disconnect size requirements.

⁴ Factory installed circuit breaker not available.

ELECTRICAL DATA

HIGH EFFICIENCY - CONSTANT AIR VOLUME - 25 TON

Model No.		LCH300H4B								
¹ Voltage - 60hz		208/230V - 3 Ph			460V - 3 Ph			575V - 3 Ph		
Compressor 1	Rated Load Amps	22.4			10.6			7.7		
	Locked Rotor Amps	149			75			54		
Compressor 2	Rated Load Amps	22.4			10.6			7.7		
	Locked Rotor Amps	149			75			54		
Compressor 3	Rated Load Amps	22.4			10.6			7.7		
	Locked Rotor Amps	149			75			54		
Compressor 4	Rated Load Amps	22.4			10.6			7.7		
	Locked Rotor Amps	149			75			54		
Outdoor Fan Motors (6)	Full Load Amps	2.4			1.3			1		
	(total)	(14.4)			(7.8)			(6)		
Standard Power Exhaust (3) 0.33 HP	Full Load Amps	2.4			1.3			1		
	(total)	(7.2)			(3.9)			(3)		
50% High Static Power Exhaust (2) 2 HP	Full Load Amps	7.5			3.4			2.7		
	(total)	(15)			(6.8)			(5.4)		
100% High Static Power Exhaust (3) 2 HP	Full Load Amps	7.5			3.4			2.7		
	(total)	(22.5)			(10.2)			(8.1)		
Service Outlet 115V GFI (amps)		15			15			20		
Indoor Blower Motor	Horsepower	5	7.5	10	5	7.5	10	5	7.5	10
	Full Load Amps	16.7	24.2	30.8	7.6	11	14	6.1	9	11
² Maximum Overcurrent Protection	Unit Only	150	150	150	70	70	80	50	50	60
	With (3) 0.33 HP Standard Power Exhaust	150	150	150	70	70	80	60	60	60
	With 50% High Static Power Exhaust (2) 2 HP	150	150	175	70	80	80	60	60	60
	With 100% High Static Power Exhaust (3) 2 HP	150	175	175	80	80	90	60	60	60
³ Minimum Circuit Ampacity	Unit Only	127	135	143	61	64	68	45	49	51
	With (3) 0.33 HP Standard Power Exhaust	128	134	142	62	65	68	46	48	52
	With 50% High Static Power Exhaust (2) 2 HP	142	150	158	68	71	75	51	54	56
	With 100% High Static Power Exhaust (3) 2 HP	149	157	165	71	75	78	53	57	59

NOTE - All units have a minimum Short Circuit Current Rating (SCCR) of 5000 amps.

¹ Extremes of operating range are plus and minus 10% of line voltage.

² HACR type breaker or fuse.

³ Refer to National or Canadian Electrical Code manual to determine wire, fuse and disconnect size requirements.

ELECTRIC HEAT DATA

HIGH EFFICIENCY - CONSTANT AIR VOLUME - 25 TON

Model No.		LCH300H4B												
¹ Voltage - 60hz - 3 phase		208/230V - 3 Ph					460V - 3 Ph			575V - 3 Ph				
Indoor Blower Motor	Horsepower	5		7.5		10		5	7.5	10	5	7.5	10	
Electric Heat Voltage		208V	240V	208V	240V	208V	240V	480V	480V	480V	600V	600V	600V	
² Maximum Overcurrent Protection	Unit+ Electric Heat	30 kW	150	150	150	150	150	150	70	70	80	50	50	60
		45 kW	⁴ 150	175	⁴ 150	175	175	175	80	90	90	70	70	70
		60 kW	⁴ 150	175	175	175	⁴ 175	200	90	90	90	70	70	80
		90 kW	⁴ 225	250	⁴ 225	250	⁴ 250	⁴ 300	125	125	150	100	100	110
		120 kW	⁴ 300	⁴ 350	⁴ 300	⁴ 350	⁴ 300	⁴ 350	175	175	175	125	150	150
	Unit+ Electric Heat and Standard Power Exhaust (3) 0.33 HP	30 kW	150	150	150	150	150	150	70	70	70	50	50	60
		45 kW	⁴ 150	175	⁴ 150	175	175	175	80	90	90	70	70	70
		60 kW	⁴ 150	175	175	175	⁴ 175	200	90	90	100	70	70	80
		90 kW	⁴ 225	250	⁴ 225	250	⁴ 250	⁴ 300	125	125	150	100	100	110
		120 kW	⁴ 300	⁴ 350	⁴ 300	⁴ 350	⁴ 300	⁴ 350	175	175	175	125	150	150
	Unit+ Electric Heat and 50% High Static Power Exhaust (2) 2 HP	30 kW	150	150	150	150	175	175	70	80	80	60	60	60
		45 kW	175	175	⁴ 175	200	⁴ 175	200	90	90	100	70	80	80
		60 kW	⁴ 175	200	⁴ 175	200	⁴ 200	225	100	100	100	80	80	80
		90 kW	⁴ 250	⁴ 300	⁴ 250	⁴ 300	⁴ 250	⁴ 300	150	150	150	110	110	110
		120 kW	⁴ 300	⁴ 350	⁴ 300	⁴ 350	350	⁴ 350	175	175	175	150	150	150
Unit+ Electric Heat and 100% High Static Power Exhaust (3) 2 HP	30 kW	150	150	175	175	175	175	80	80	90	60	60	60	
	45 kW	⁴ 175	200	200	200	⁴ 200	225	90	100	100	80	80	80	
	60 kW	⁴ 175	200	⁴ 200	225	⁴ 200	225	100	100	110	80	80	90	
	90 kW	⁴ 250	⁴ 300	⁴ 250	⁴ 300	300	⁴ 300	150	150	150	110	110	125	
	120 kW	⁴ 300	⁴ 350	350	⁴ 350	⁴ 350	⁴ 400	175	175	175	150	150	150	
³ Minimum Circuit Ampacity	Unit+ Electric Heat	30 kW	127	127	135	135	143	143	61	64	68	45	49	51
		45 kW	139	157	148	166	156	174	78	82	86	62	66	68
		60 kW	146	166	156	175	164	183	82	86	90	66	69	72
		90 kW	209	238	218	247	227	256	118	123	126	95	98	101
		120 kW	272	310	281	319	289	328	154	159	162	124	127	130
	Unit+ Electric Heat and Standard Power Exhaust (3) 0.33 HP	30 kW	128	128	134	134	142	142	62	65	68	46	48	52
		45 kW	140	158	148	166	157	175	79	83	87	63	66	70
		60 kW	148	167	155	175	165	184	84	87	91	67	70	73
		90 kW	210	239	218	247	227	256	120	123	127	96	98	102
		120 kW	273	311	281	319	290	328	156	159	163	125	127	131
	Unit+ Electric Heat and 50% High Static Power Exhaust (2) 2 HP	30 kW	142	142	150	150	158	158	68	71	75	51	55	57
		45 kW	157	175	167	185	175	193	86	90	94	69	73	75
		60 kW	165	184	175	194	183	202	91	95	99	73	76	79
		90 kW	228	257	237	266	245	274	127	131	135	101	105	108
		120 kW	290	329	300	338	308	346	163	167	171	130	134	136
	Unit+ Electric Heat and 100% High Static Power Exhaust (3) 2 HP	30 kW	149	149	157	157	165	165	71	75	78	54	58	60
		45 kW	167	185	176	194	184	202	90	95	98	72	76	79
		60 kW	175	194	184	203	192	211	95	99	103	76	80	82
		90 kW	237	266	247	275	255	284	131	135	139	105	108	111
		120 kW	300	338	309	348	317	356	167	171	175	134	137	140

¹ Extremes of operating range are plus and minus 10% of line voltage.

² HACR type breaker or fuse.

³ Refer to National or Canadian Electrical Code manual to determine wire, fuse and disconnect size requirements.

⁴ Factory installed circuit breaker not available.

ELECTRICAL DATA HIGH EFFICIENCY - VARIABLE/MULTI-STAGE AIR VOLUME - 25 TON

Model No.		LCH300H4V, LCH300H4M								
¹ Voltage - 60hz		208/230V - 3 Ph			460V - 3 Ph			575V - 3 Ph		
Compressor 1	Rated Load Amps	22.4			10.6			7.7		
	Locked Rotor Amps	149			75			54		
Compressor 2	Rated Load Amps	22.4			10.6			7.7		
	Locked Rotor Amps	149			75			54		
Compressor 3	Rated Load Amps	22.4			10.6			7.7		
	Locked Rotor Amps	149			75			54		
Compressor 4	Rated Load Amps	22.4			10.6			7.7		
	Locked Rotor Amps	149			75			54		
Outdoor Fan Motors (6)	Full Load Amps	2.4			1.3			1		
	(total)	(14.4)			(7.8)			(6)		
Standard Power Exhaust (3) 0.33 HP	Full Load Amps	2.4			1.3			1		
	(total)	(7.2)			(3.9)			(3)		
50% High Static Power Exhaust (2) 2 HP	Full Load Amps	7.5			3.4			2.7		
	(total)	(15)			(6.8)			(5.4)		
100% High Static Power Exhaust (3) 2 HP	Full Load Amps	7.5			3.4			2.7		
	(total)	(22.5)			(10.2)			(8.1)		
Service Outlet 115V GFI (amps)		15			15			20		
Indoor Blower Motor	Horsepower	5	7.5	10	5	7.5	10	5	7.5	10
	Full Load Amps	16.7	24.2	30.8	7.6	11	14	6.1	9	11
² Maximum Overcurrent Protection	Unit Only	150	150	150	70	70	80	50	50	60
	With (3) 0.33 HP Standard Power Exhaust	150	150	175	70	70	80	50	60	60
	With 50% High Static Power Exhaust (2) 2 HP	150	150	175	70	80	80	60	60	60
	With 100% High Static Power Exhaust (3) 2 HP	150	175	175	80	80	90	60	60	60
³ Minimum Circuit Ampacity	Unit Only	127	135	143	61	64	68	45	49	51
	With (3) 0.33 HP Standard Power Exhaust	134	142	150	65	68	72	48	52	54
	With 50% High Static Power Exhaust (2) 2 HP	142	150	158	68	71	75	51	54	56
	With 100% High Static Power Exhaust (3) 2 HP	149	157	165	71	75	78	53	57	59

NOTE - All units have a minimum Short Circuit Current Rating (SCCR) of 5000 amps.

¹ Extremes of operating range are plus and minus 10% of line voltage.

² HACR type breaker or fuse.

³ Refer to National or Canadian Electrical Code manual to determine wire, fuse and disconnect size requirements.

ELECTRIC HEAT DATA HIGH EFFICIENCY - VARIABLE/MULTI-STAGE AIR VOLUME - 25 TON

Model No.		LCH300H4V, LCH300H4M													
¹ Voltage - 60hz - 3 phase		208/230V - 3 Ph						460V - 3 Ph			575V - 3 Ph				
Indoor Blower Motor	Horsepower	5		7.5		10		5	7.5	10	5	7.5	10		
Electric Heat Voltage		208V	240V	208V	240V	208V	240V	480V	480V	480V	600V	600V	600V		
² Maximum Overcurrent Protection	Unit+ Electric Heat	30 kW	150	150	150	150	150	70	70	80	50	50	60		
		45 kW	⁴ 150	175	⁴ 150	175	175	175	80	90	90	70	70	70	
		60 kW	⁴ 150	175	175	175	⁴ 175	200	90	90	90	70	70	80	
		90 kW	⁴ 225	250	⁴ 225	250	⁴ 250	⁴ 300	125	125	150	100	100	110	
		120 kW	⁴ 300	⁴ 350	⁴ 300	⁴ 350	⁴ 300	⁴ 350	175	175	175	125	150	150	
		Unit+ Electric Heat	30 kW	150	150	150	175	175	70	70	80	50	60	60	
			45 kW	⁴ 150	175	175	175	⁴ 175	200	90	90	100	70	70	80
			60 kW	175	175	⁴ 175	200	⁴ 175	200	90	100	100	70	80	80
			90 kW	⁴ 225	250	⁴ 250	⁴ 300	⁴ 250	⁴ 300	125	150	150	100	110	110
			120 kW	⁴ 300	⁴ 350	⁴ 300	⁴ 350	⁴ 300	⁴ 350	175	175	175	150	150	150
		Unit+ Electric Heat and Standard Power Exhaust (3) 0.33 HP	30 kW	150	150	150	175	175	70	80	80	60	60	60	
			45 kW	175	175	⁴ 175	200	⁴ 175	200	90	90	100	70	80	80
			60 kW	⁴ 175	200	⁴ 175	200	⁴ 200	225	100	100	100	80	80	80
			90 kW	⁴ 250	⁴ 300	⁴ 250	⁴ 300	⁴ 250	⁴ 300	150	150	150	110	110	110
			120 kW	⁴ 300	⁴ 350	⁴ 300	⁴ 350	350	⁴ 350	175	175	175	150	150	150
	Unit+ Electric Heat and 100% High Static Power Exhaust (2) 2 HP	30 kW	150	150	175	175	175	80	80	90	60	60	60		
		45 kW	⁴ 175	200	200	200	⁴ 200	225	90	100	100	80	80	80	
		60 kW	⁴ 175	200	⁴ 200	225	⁴ 200	225	100	100	110	80	80	90	
		90 kW	⁴ 250	⁴ 300	⁴ 250	⁴ 300	300	⁴ 300	150	150	150	110	110	125	
		120 kW	⁴ 300	⁴ 350	350	⁴ 350	⁴ 400	175	175	175	150	150	150		
³ Minimum Circuit Ampacity	Unit+ Electric Heat	30 kW	127	127	135	135	143	143	61	64	68	45	49	51	
		45 kW	139	157	148	166	156	174	78	82	86	62	66	68	
		60 kW	146	166	156	175	164	183	82	86	90	66	69	72	
		90 kW	209	238	218	247	227	256	118	123	126	95	98	101	
		120 kW	272	310	281	319	289	328	154	159	162	124	127	130	
		Unit+ Electric Heat and Standard Power Exhaust (3) 0.33 HP	30 kW	134	134	142	142	150	150	65	68	72	48	52	54
			45 kW	148	166	157	175	165	183	83	87	91	66	70	72
			60 kW	155	175	165	184	173	192	87	91	95	70	73	76
			90 kW	218	247	227	256	236	265	123	127	131	98	102	105
			120 kW	281	319	290	328	298	337	159	163	167	127	131	133
		Unit+ Electric Heat and 50% High Static Power Exhaust (2) 2 HP	30 kW	142	142	150	150	158	158	68	71	75	51	55	57
			45 kW	157	175	167	185	175	193	86	90	94	69	73	75
			60 kW	165	184	175	194	183	202	91	95	99	73	76	79
			90 kW	228	257	237	266	245	274	127	131	135	101	105	108
			120 kW	290	329	300	338	308	346	163	167	171	130	134	136
		Unit+ Electric Heat and 100% High Static Power Exhaust (3) 2 HP	30 kW	149	149	157	157	165	165	71	75	78	54	58	60
			45 kW	167	185	176	194	184	202	90	95	98	72	76	79
			60 kW	175	194	184	203	192	211	95	99	103	76	80	82
			90 kW	237	266	247	275	255	284	131	135	139	105	108	111
			120 kW	300	338	309	348	317	356	167	171	175	134	137	140

¹ Extremes of operating range are plus and minus 10% of line voltage.

² HACR type breaker or fuse.

³ Refer to National or Canadian Electrical Code manual to determine wire, fuse and disconnect size requirements.

⁴ Factory installed circuit breaker not available.

ELECTRICAL DATA
HIGH EFFICIENCY - CONSTANT AIR VOLUME - 30 TON

Model No.		LCH360H4B								
		208/230V - 3 Ph			460V - 3 Ph			575V - 3 Ph		
¹ Voltage - 60hz										
Compressor 1	Rated Load Amps	25			12.2			9		
	Locked Rotor Amps	164			100			78		
Compressor 2	Rated Load Amps	25			12.2			9		
	Locked Rotor Amps	164			100			78		
Compressor 3	Rated Load Amps	25			12.2			9		
	Locked Rotor Amps	164			100			78		
Compressor 4	Rated Load Amps	25			12.2			9		
	Locked Rotor Amps	164			100			78		
Outdoor Fan Motors (6)	Full Load Amps	2.4			1.3			1		
	(total)	(14.4)			(7.8)			(6)		
Standard Power Exhaust (3) 0.33 HP	Full Load Amps	2.4			1.3			1		
	(total)	(7.2)			(3.9)			(3)		
50% High Static Power Exhaust (2) 2 HP	Full Load Amps	7.5			3.4			2.7		
	(total)	(15)			(6.8)			(5.4)		
100% High Static Power Exhaust (3) 2 HP	Full Load Amps	7.5			3.4			2.7		
	(total)	(22.5)			(10.2)			(8.1)		
Service Outlet 115V GFI (amps)		15			15			20		
Indoor Blower Motor	Horsepower	5	7.5	10	5	7.5	10	5	7.5	10
	Full Load Amps	16.7	24.2	30.8	7.6	11	14	6.1	9	11
² Maximum Overcurrent Protection	Unit Only	150	150	175	70	80	80	60	60	60
	With (3) 0.33 HP Standard Power Exhaust	150	175	175	80	80	90	60	60	60
	With 50% High Static Power Exhaust (2) 2 HP	175	175	175	80	80	90	60	60	70
	With 100% High Static Power Exhaust (3) 2 HP	175	175	200	80	90	90	60	70	70
³ Minimum Circuit Ampacity	Unit Only	138	145	153	68	71	75	51	54	56
	With (3) 0.33 HP Standard Power Exhaust	145	153	161	72	75	78	54	57	59
	With 50% High Static Power Exhaust (2) 2 HP	153	160	168	75	78	81	56	59	62
	With 100% High Static Power Exhaust (3) 2 HP	160	168	176	78	81	85	59	62	64

NOTE - All units have a minimum Short Circuit Current Rating (SCCR) of 5000 amps.

¹ Extremes of operating range are plus and minus 10% of line voltage.

² HACR type breaker or fuse.

³ Refer to National or Canadian Electrical Code manual to determine wire, fuse and disconnect size requirements.

ELECTRIC HEAT DATA

HIGH EFFICIENCY - CONSTANT AIR VOLUME - 30 TON

Model No.		LCH360H4B												
¹ Voltage - 60hz - 3 phase		208/230V - 3 Ph				460V - 3 Ph			575V - 3 Ph					
Indoor Blower Motor	Horsepower	5		7.5		10		5	7.5	10	5	7.5	10	
Electric Heat Voltage		208V	240V	208V	240V	208V	240V	480V	480V	480V	600V	600V	600V	
² Maximum Overcurrent Protection	Unit+ Electric Heat	30 kW	150	150	150	150	175	175	70	80	80	60	60	60
		45 kW	⁴ 150	175	⁴ 150	175	175	175	80	90	90	70	70	70
		60 kW	⁴ 150	175	175	175	⁴ 175	200	90	90	90	70	70	80
		90 kW	⁴ 225	250	⁴ 225	250	⁴ 250	⁴ 300	125	125	150	100	100	110
		120 kW	⁴ 300	⁴ 350	⁴ 300	⁴ 350	⁴ 300	⁴ 350	175	175	175	125	150	150
	Unit+ Electric Heat and Standard Power Exhaust (3) 0.33 HP	30 kW	150	150	175	175	175	175	80	80	90	60	60	60
		45 kW	⁴ 150	175	175	175	⁴ 175	200	90	90	100	70	70	80
		60 kW	175	175	⁴ 175	200	⁴ 175	200	90	100	100	70	80	80
		90 kW	⁴ 225	250	⁴ 250	⁴ 300	⁴ 250	⁴ 300	125	150	150	100	110	110
		120 kW	⁴ 300	⁴ 350	⁴ 300	⁴ 350	⁴ 300	⁴ 350	175	175	175	150	150	150
	Unit+ Electric Heat and 50% High Static Power Exhaust (2) 2 HP	30 kW	175	175	175	175	175	175	80	80	90	60	60	70
		45 kW	175	175	⁴ 175	200	⁴ 175	200	90	90	100	70	80	80
		60 kW	⁴ 175	200	⁴ 175	200	⁴ 200	225	100	100	100	80	80	80
		90 kW	⁴ 250	⁴ 300	⁴ 250	⁴ 300	⁴ 250	⁴ 300	150	150	150	110	110	110
		120 kW	⁴ 300	⁴ 350	⁴ 300	⁴ 350	350	⁴ 350	175	175	175	150	150	150
Unit+ Electric Heat and 100% High Static Power Exhaust (3) 2 HP	30 kW	175	175	175	175	200	200	80	90	90	60	70	70	
	45 kW	⁴ 175	200	200	200	⁴ 200	225	90	100	100	80	80	80	
	60 kW	⁴ 175	200	⁴ 200	225	⁴ 200	225	100	100	110	80	80	90	
	90 kW	⁴ 250	⁴ 300	⁴ 250	⁴ 300	300	⁴ 300	150	150	150	110	110	125	
	120 kW	⁴ 300	⁴ 350	350	⁴ 350	⁴ 350	⁴ 400	175	175	175	150	150	150	
³ Minimum Circuit Ampacity	Unit+ Electric Heat	30 kW	138	138	145	145	153	153	68	71	75	51	54	56
		45 kW	139	157	148	166	156	174	78	82	86	62	66	68
		60 kW	146	166	156	175	164	183	82	86	90	66	69	72
		90 kW	209	238	218	247	227	256	118	123	126	95	98	101
		120 kW	272	310	281	319	289	328	154	159	162	124	127	130
	Unit+ Electric Heat and Standard Power Exhaust (3) 0.33 HP	30 kW	145	145	153	153	161	161	72	75	78	54	57	59
		45 kW	148	166	157	175	165	183	83	87	91	66	70	72
		60 kW	155	175	165	184	173	192	87	91	95	70	73	76
		90 kW	218	247	227	256	236	265	123	127	131	98	102	105
		120 kW	281	319	290	328	298	337	159	163	167	127	131	133
	Unit+ Electric Heat and 50% High Static Power Exhaust (2) 2 HP	30 kW	153	153	160	160	168	168	75	78	81	56	59	62
		45 kW	157	175	167	185	175	193	86	90	94	69	73	75
		60 kW	165	184	175	194	183	202	91	95	99	73	76	79
		90 kW	228	257	237	266	245	274	127	131	135	101	105	108
		120 kW	290	329	300	338	308	346	163	167	171	130	134	136
	Unit+ Electric Heat and 100% High Static Power Exhaust (3) 2 HP	30 kW	160	160	168	168	176	176	78	81	85	59	62	64
		45 kW	167	185	176	194	184	202	90	95	98	72	76	79
		60 kW	175	194	184	203	192	211	95	99	103	76	80	82
		90 kW	237	266	247	275	255	284	131	135	139	105	108	111
		120 kW	300	338	309	348	317	356	167	171	175	134	137	140

¹ Extremes of operating range are plus and minus 10% of line voltage.

² HACR type breaker or fuse.

³ Refer to National or Canadian Electrical Code manual to determine wire, fuse and disconnect size requirements.

⁴ Factory installed circuit breaker not available.

ELECTRICAL DATA HIGH EFFICIENCY - VARIABLE/MULTI-STAGE AIR VOLUME - 30 TON

Model No.		LCH360H4V, LCH360H4M								
¹ Voltage - 60hz		208/230V - 3 Ph			460V - 3 Ph			575V - 3 Ph		
Compressor 1	Rated Load Amps	25			12.2			9		
	Locked Rotor Amps	164			100			78		
Compressor 2	Rated Load Amps	25			12.2			9		
	Locked Rotor Amps	164			100			78		
Compressor 3	Rated Load Amps	25			12.2			9		
	Locked Rotor Amps	164			100			78		
Compressor 4	Rated Load Amps	25			12.2			9		
	Locked Rotor Amps	164			100			78		
Outdoor Fan Motors (6)	Full Load Amps	2.4			1.3			1		
	(total)	(14.4)			(7.8)			(6)		
Standard Power Exhaust (3) 0.33 HP	Full Load Amps	2.4			1.3			1		
	(total)	(7.2)			(3.9)			(3)		
50% High Static Power Exhaust (2) 2 HP		7.5 (15)			3.4 (6.8)			2.7 (5.4)		
100% High Static Power Exhaust (3) 2 HP		7.5 (22.5)			3.4 (10.2)			2.7 (8.1)		
Service Outlet 115V GFI (amps)		15			15			20		
Indoor Blower Motor	Horsepower	5	7.5	10	5	7.5	10	5	7.5	10
	Full Load Amps	16.7	24.2	30.8	7.6	11	14	6.1	9	11
² Maximum Overcurrent Protection	Unit Only	150	150	175	70	80	80	60	60	60
	With (3) 0.33 HP Standard Power Exhaust	150	175	175	80	80	90	60	60	60
	With 50% High Static Power Exhaust (2) 2 HP	175	175	175	80	80	90	60	60	70
	With 100% High Static Power Exhaust (3) 2 HP	175	175	200	80	90	90	60	70	70
³ Minimum Circuit Ampacity	Unit Only	138	145	153	68	71	75	51	54	56
	With (3) 0.33 HP Standard Power Exhaust	145	153	161	72	75	78	54	57	59
	With 50% High Static Power Exhaust (2) 2 HP	153	160	168	75	78	81	56	59	62
	With 100% High Static Power Exhaust (3) 2 HP	160	168	176	78	81	85	59	62	64

NOTE - All units have a minimum Short Circuit Current Rating (SCCR) of 5000 amps.

¹ Extremes of operating range are plus and minus 10% of line voltage.

² HACR type breaker or fuse.

³ Refer to National or Canadian Electrical Code manual to determine wire, fuse and disconnect size requirements.

ELECTRIC HEAT DATA HIGH EFFICIENCY - VARIABLE/MULTI-STAGE AIR VOLUME - 30 TON

Model No.		LCH360H4V, LCH360H4M												
¹ Voltage - 60hz - 3 phase		208/230V - 3 Ph						460V - 3 Ph			575V - 3 Ph			
Indoor Blower Motor	Horsepower	5		7.5		10		5	7.5	10	5	7.5	10	
Electric Heat Voltage		208V	240V	208V	240V	208V	240V	480V	480V	480V	600V	600V	600V	
² Maximum Overcurrent Protection	Unit+ Electric Heat	30 kW	150	150	150	150	175	175	70	80	80	60	60	60
		45 kW	⁴ 150	175	⁴ 150	175	175	175	80	90	90	70	70	70
		60 kW	⁴ 150	175	175	175	⁴ 175	200	90	90	90	70	70	80
		90 kW	⁴ 225	250	⁴ 225	250	⁴ 250	⁴ 300	125	125	150	100	100	110
		120 kW	⁴ 300	⁴ 350	⁴ 300	⁴ 350	⁴ 300	⁴ 350	175	175	175	125	150	150
	Unit+ Electric Heat and Standard Power Exhaust (3) 0.33 HP	30 kW	150	150	175	175	175	175	80	80	90	60	60	60
		45 kW	⁴ 150	175	175	175	⁴ 175	200	90	90	100	70	70	80
		60 kW	175	175	⁴ 175	200	⁴ 175	200	90	100	100	70	80	80
		90 kW	⁴ 225	250	⁴ 250	⁴ 300	⁴ 250	⁴ 300	125	150	150	100	110	110
		120 kW	⁴ 300	⁴ 350	⁴ 300	⁴ 350	⁴ 300	⁴ 350	175	175	175	150	150	150
	Unit+ Electric Heat and 50% High Static Power Exhaust (2) 2 HP	30 kW	175	175	175	175	175	175	80	80	90	60	60	70
		45 kW	175	175	⁴ 175	200	⁴ 175	200	90	90	100	70	80	80
		60 kW	⁴ 175	200	⁴ 175	200	⁴ 200	225	100	100	100	80	80	80
		90 kW	⁴ 250	⁴ 300	⁴ 250	⁴ 300	⁴ 250	⁴ 300	150	150	150	110	110	110
		120 kW	⁴ 300	⁴ 350	⁴ 300	⁴ 350	350	⁴ 350	175	175	175	150	150	150
Unit+ Electric Heat and 100% High Static Power Exhaust (3) 2 HP	30 kW	175	175	175	175	200	200	80	90	90	60	70	70	
	45 kW	⁴ 175	200	200	200	⁴ 200	225	90	100	100	80	80	80	
	60 kW	⁴ 175	200	⁴ 200	225	⁴ 200	225	100	100	110	80	80	90	
	90 kW	⁴ 250	⁴ 300	⁴ 250	⁴ 300	300	⁴ 300	150	150	150	110	110	125	
	120 kW	⁴ 300	⁴ 350	350	⁴ 350	⁴ 350	⁴ 400	175	175	175	150	150	150	
³ Minimum Circuit Ampacity	Unit+ Electric Heat	30 kW	138	138	145	145	153	153	68	71	75	51	54	56
		45 kW	139	157	148	166	156	174	78	82	86	62	66	68
		60 kW	146	166	156	175	164	183	82	86	90	66	69	72
		90 kW	209	238	218	247	227	256	118	123	126	95	98	101
		120 kW	272	310	281	319	289	328	154	159	162	124	127	130
	Unit+ Electric Heat and Standard Power Exhaust (3) 0.33 HP	30 kW	145	145	153	153	161	161	72	75	78	54	57	59
		45 kW	148	166	157	175	165	183	83	87	91	66	70	72
		60 kW	155	175	165	184	173	192	87	91	95	70	73	76
		90 kW	218	247	227	256	236	265	123	127	131	98	102	105
		120 kW	281	319	290	328	298	337	159	163	167	127	131	133
	Unit+ Electric Heat and 50% High Static Power Exhaust (2) 2 HP	30 kW	153	153	160	160	168	168	75	78	81	56	59	62
		45 kW	157	175	167	185	175	193	86	90	94	69	73	75
		60 kW	165	184	175	194	183	202	91	95	99	73	76	79
		90 kW	228	257	237	266	245	274	127	131	135	101	105	108
		120 kW	290	329	300	338	308	346	163	167	171	130	134	136
	Unit+ Electric Heat and 100% High Static Power Exhaust (3) 2 HP	30 kW	160	160	168	168	176	176	78	81	85	59	62	64
		45 kW	167	185	176	194	184	202	90	95	98	72	76	79
		60 kW	175	194	184	203	192	211	95	99	103	76	80	82
		90 kW	237	266	247	275	255	284	131	135	139	105	108	111
		120 kW	300	338	309	348	317	356	167	171	175	134	137	140

¹ Extremes of operating range are plus and minus 10% of line voltage.

² HACR type breaker or fuse.

³ Refer to National or Canadian Electrical Code manual to determine wire, fuse and disconnect size requirements.

⁴ Factory installed circuit breaker not available.

ELECTRIC HEAT CAPACITIES

Volts Input	30 kW			45 kW			60 kW			90 kW			120 kW		
	kW Input	Btuh Output	No. of Stages	kW Input	Btuh Output	No. of Stages	kW Input	Btuh Output	No. of Stages	kW Input	Btuh Output	No. of Stages	kW Input	Btuh Output	No. of Stages
208	22.5	76,800	1	33.8	115,300	2	45.0	153,600	2	67.6	230,700	2	90.2	307,800	2
220	25.2	86,000	1	37.8	129,000	2	50.4	172,000	2	75.6	258,000	2	100.8	344,000	2
230	27.5	93,900	1	41.3	141,000	2	55.1	188,000	2	82.7	282,200	2	110.2	376,100	2
240	30.0	102,400	1	45.0	153,600	2	60.0	204,800	2	90.0	307,100	2	120.0	409,500	2
440	25.2	86,000	1	37.8	129,000	2	50.4	172,000	2	75.6	258,000	2	100.8	344,000	2
460	27.5	93,900	1	41.3	141,000	2	55.1	188,000	2	82.7	282,200	2	110.2	376,100	2
480	30.0	102,400	1	45.0	153,600	2	60.0	204,800	2	90.0	307,100	2	120.0	409,500	2
550	25.2	86,000	1	37.8	129,000	2	50.4	172,000	2	75.6	258,000	2	100.8	344,000	2
575	27.5	93,900	1	41.3	141,000	2	55.1	188,000	2	82.7	282,200	2	110.2	376,100	2
600	30.0	102,400	1	45.0	153,600	2	60.0	204,800	2	90.0	307,100	2	120.0	409,500	2

ELECTRICAL ACCESSORIES

HIGH EFFICIENCY - 20 TON

Model No.		LCH242H4									
Voltage - 60hz - 3 phase		208/230V			460V			575V			
Indoor Blower Motor Horsepower		5	7.5	10	5	7.5	10	5	7.5	10	
Disconnect	Unit Only	54W86	54W86	54W86	54W85	54W85	54W85	54W85	54W85	54W85	
	Unit+ Electric Heat and Standard Power Exhaust (3) 0.33 HP	0 kW	54W86	54W86	54W86	54W85	54W85	54W85	54W85	54W85	54W85
	30 kW	54W86	54W86	54W86	54W85	54W85	54W85	54W85	54W85	54W85	54W85
	45 kW	54W87	54W87	54W87	54W85	54W85	54W86	54W85	54W85	54W85	54W85
	60 kW	54W87	54W87	54W87	54W86	54W86	54W86	54W85	54W86	54W86	54W86
	90 kW	N/A	N/A	N/A	54W86	54W86	54W86	54W86	54W86	54W86	54W86
	120 kW	N/A	N/A	N/A	54W87	54W87	54W87	54W86	54W86	54W86	54W86
	Unit+ Electric Heat and 50% High Static Power Exhaust (2) 2 HP	0 kW	54W86	54W86	54W87	54W85	54W85	54W85	54W85	54W85	54W85
	30 kW	54W86	54W86	54W87	54W85	54W85	54W85	54W85	54W85	54W85	54W85
	45 kW	54W87	54W87	54W87	54W85	54W86	54W86	54W85	54W85	54W85	54W85
	60 kW	54W87	54W87	54W87	54W86	54W86	54W86	54W85	54W86	54W86	54W86
	90 kW	N/A	N/A	N/A	54W86	54W86	54W86	54W86	54W86	54W86	54W86
	120 kW	N/A	N/A	N/A	54W87	54W87	54W87	54W86	54W86	54W86	54W87
	Unit+ Electric Heat and 100% High Static Power Exhaust (3) 2 HP	0 kW	54W86	54W87	54W87	54W85	54W85	54W85	54W85	54W85	54W85
	30 kW	54W86	54W87	54W87	54W85	54W85	54W85	54W85	54W85	54W85	54W85
	45 kW	54W87	54W87	54W87	54W86	54W86	54W86	54W85	54W85	54W85	54W85
	60 kW	54W87	54W87	54W87	54W86	54W86	54W86	54W86	54W86	54W86	54W86
	90 kW	N/A	N/A	N/A	54W86	54W86	54W87	54W86	54W86	54W86	54W86
120 kW	N/A	N/A	N/A	54W87	54W87	54W87	54W86	54W87	54W86	54W87	

ELECTRICAL ACCESSORIES

HIGH EFFICIENCY - 25 TON

Model No.		LCH300H4									
Voltage - 60hz - 3 phase		208/230V			460V			575V			
Indoor Blower Motor	Horsepower	5	7.5	10	5	7.5	10	5	7.5	10	
Disconnect	Unit Only	54W86	54W87	54W87	54W85	54W85	54W85	54W85	54W85	54W85	
	Unit+ 0 kW	54W86	54W87	54W87	54W85	54W85	54W85	54W85	54W85	54W85	
	Electric Heat and Standard Power Exhaust (3) 0.33 HP	30 kW	54W86	54W87	54W87	54W85	54W85	54W85	54W85	54W85	54W85
		45 kW	54W87	54W87	54W87	54W85	54W85	54W86	54W85	54W85	54W85
		60 kW	54W87	54W87	54W87	54W86	54W86	54W86	54W85	54W86	54W86
		90 kW	N/A	N/A	N/A	54W86	54W86	54W86	54W86	54W86	54W86
		120 kW	N/A	N/A	N/A	54W87	54W87	54W87	54W86	54W86	54W86
	Unit+ Electric Heat and 50% High Static Power Exhaust (2) 2 HP	0 kW	54W87	54W87	54W87	54W85	54W85	54W86	54W85	54W85	54W85
		30 kW	54W87	54W87	54W87	54W85	54W85	54W86	54W85	54W85	54W85
		45 kW	54W87	54W87	54W87	54W85	54W86	54W86	54W85	54W85	54W85
		60 kW	54W87	54W87	54W87	54W86	54W86	54W86	54W85	54W86	54W86
		90 kW	N/A	N/A	N/A	54W86	54W86	54W86	54W86	54W86	54W86
	Unit+ Electric Heat and 100% High Static Power Exhaust (3) 2 HP	120 kW	N/A	N/A	N/A	54W87	54W87	54W87	54W86	54W86	54W87
		0 kW	54W87	54W87	54W87	54W85	54W86	54W86	54W85	54W85	54W85
		30 kW	54W87	54W87	54W87	54W85	54W86	54W86	54W85	54W85	54W85
		45 kW	54W87	54W87	54W87	54W86	54W86	54W86	54W85	54W85	54W85
		60 kW	54W87	54W87	54W87	54W86	54W86	54W86	54W86	54W86	54W86
	90 kW	N/A	N/A	N/A	54W86	54W86	54W87	54W86	54W86	54W86	
	120 kW	N/A	N/A	N/A	54W87	54W87	54W87	54W86	54W87	54W87	

ELECTRICAL ACCESSORIES

HIGH EFFICIENCY - 30 TON

Model No.		LCH360H4									
Voltage - 60hz - 3 phase		208/230V			460V			575V			
Indoor Blower Motor	Horsepower	5	7.5	10	5	7.5	10	5	7.5	10	
Disconnect	Unit Only	54W87	54W87	54W87	54W85	54W86	54W86	54W85	54W85	54W85	
	Unit+ 0 kW	54W87	54W87	54W87	54W85	54W86	54W86	54W85	54W85	54W85	
	Electric Heat and Standard Power Exhaust (3) 0.33 HP	30 kW	54W87	54W87	54W87	54W85	54W86	54W86	54W85	54W85	54W85
		45 kW	54W87	54W87	54W87	54W85	54W86	54W86	54W85	54W85	54W85
		60 kW	54W87	54W87	54W87	54W86	54W86	54W86	54W85	54W86	54W86
		90 kW	N/A	N/A	N/A	54W86	54W86	54W86	54W86	54W86	54W86
		120 kW	N/A	N/A	N/A	54W87	54W87	54W87	54W86	54W86	54W86
	Unit+ Electric Heat and 50% High Static Power Exhaust (2) 2 HP	0 kW	54W87	54W87	54W87	54W86	54W86	54W86	54W85	54W85	54W85
		30 kW	54W87	54W87	54W87	54W86	54W86	54W86	54W85	54W85	54W85
		45 kW	54W87	54W87	54W87	54W86	54W86	54W86	54W85	54W85	54W85
		60 kW	54W87	54W87	54W87	54W86	54W86	54W86	54W85	54W86	54W86
		90 kW	N/A	N/A	N/A	54W86	54W86	54W86	54W86	54W86	54W86
	Unit+ Electric Heat and 100% High Static Power Exhaust (3) 2 HP	120 kW	N/A	N/A	N/A	54W87	54W87	54W87	54W86	54W86	54W87
		0 kW	54W87	54W87	54W87	54W86	54W86	54W86	54W85	54W85	54W85
		30 kW	54W87	54W87	54W87	54W86	54W86	54W86	54W85	54W85	54W85
		45 kW	54W87	54W87	54W87	54W86	54W86	54W86	54W85	54W85	54W85
		60 kW	54W87	54W87	54W87	54W86	54W86	54W86	54W86	54W86	54W86
	90 kW	N/A	N/A	N/A	54W86	54W86	54W87	54W86	54W86	54W86	
	120 kW	N/A	N/A	N/A	54W87	54W87	54W87	54W86	54W87	54W87	

UNIT CLEARANCES

Unit With Economizer

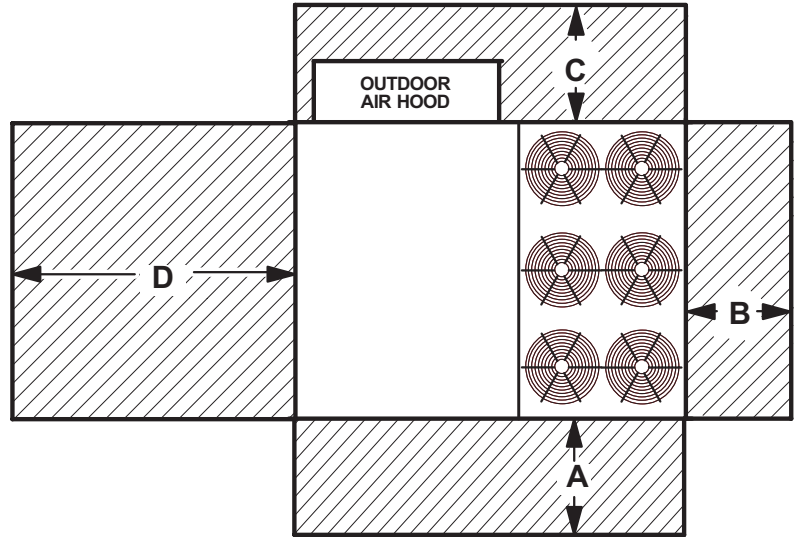

¹ Unit Clearance	A		B		C		D		Top Clearance
	in.	mm	in.	mm	in.	mm	in.	mm	
Service Clearance	60	1524	36	914	36	914	66	1676	Unobstructed
Minimum Operation Clearance	45	1143	36	914	36	914	41	1041	

NOTE - Entire perimeter of unit base requires support when elevated above the mounting surface.

¹ **Service Clearance** - Required for removal of serviceable parts.

Minimum Operation Clearance - Required clearance for proper unit operation.

Unit With High Static Power Exhaust Fans

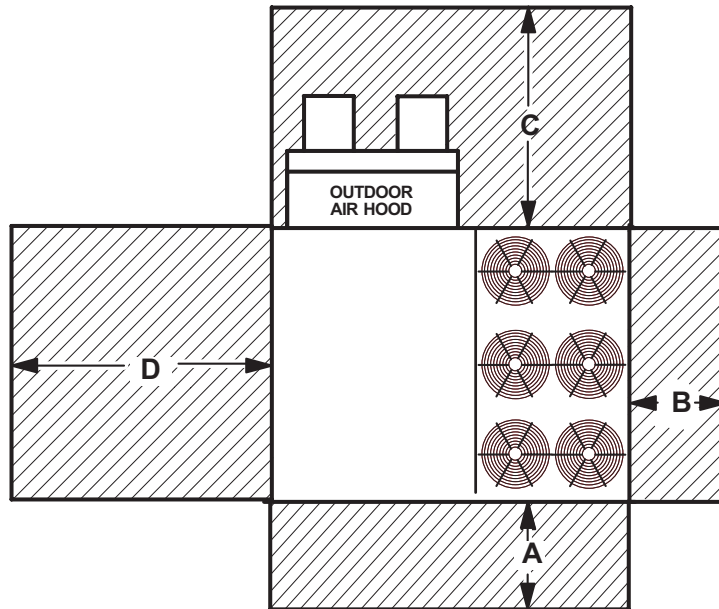

¹ Unit Clearance	A		B		C		D		Top Clearance
	in.	mm	in.	mm	in.	mm	in.	mm	
Service Clearance	60	1524	36	914	80	2032	66	1676	Unobstructed
Minimum Operation Clearance	45	1143	36	914	80	2032	41	1041	

NOTE - Entire perimeter of unit base requires support when elevated above the mounting surface.

¹ **Service Clearance** - Required for removal of serviceable parts.

Minimum Operation Clearance - Required clearance for proper unit operation.

UNIT CLEARANCES

Unit With Horizontal Barometric Relief Dampers

NOTE Allow adequate clearance for duct and barometric relief damper installation.

NOTE Dampers may be installed on each side of return air duct or end to end on one side of return air duct.

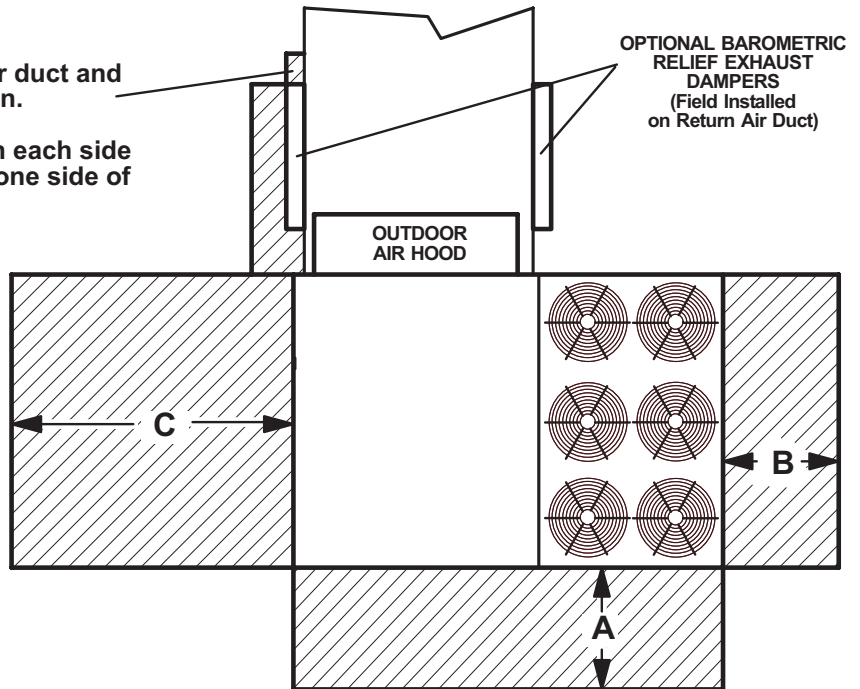

¹ Unit Clearance	A		B		C		Top Clearance
	in.	mm	in.	mm	in.	mm	
Service Clearance	60	1524	36	914	66	1676	Unobstructed
Minimum Operation Clearance	45	1143	36	914	41	1041	

NOTE - Entire perimeter of unit base requires support when elevated above the mounting surface.

¹ **Service Clearance** - Required for removal of serviceable parts.

Minimum Operation Clearance - Required clearance for proper unit operation.

OUTDOOR SOUND DATA

Unit Model Number	Octave Band Sound Power Levels dBA, re 10 ⁻¹² Watts - Center Frequency - Hz							¹ Sound Rating Number (dBA)
	125	250	500	1000	2000	4000	8000	
242, 300, 360	84	85	90	90	85	80	72	95

Note - The octave band sound power data does not include tonal corrections.

¹ Tested according to AHRI Standard 370-2001 test conditions (includes pure tone penalty).

Sound Rating Number is the overall A-Weighted Sound Power Level, (LWA), dB (100 Hz to 10,000 Hz).

WEIGHT DATA

Model Number	Net		Shipping	
	lbs.	kg	lbs.	kg
242 Base Unit	2997	1359	3207	1455
242 Max. Unit	3409	1546	3619	1642
300 Base Unit	2997	1359	3207	1455
300 Max. Unit	3509	1592	3719	1687
360 Base Unit	2997	1359	3207	1455
360 Max. Unit	3509	1592	3719	1687

OPTIONS / ACCESSORIES

Description	Shipping Weight	
	lbs.	kg
CEILING DIFFUSERS		
Step-Down LARTD30/36S	625	283
Flush LAFD30/36S	625	283
Transitions LASRT30/36	85	39
ECONOMIZER / OUTDOOR AIR / EXHAUST		
Economizer	138	63
Barometric Relief		
Downflow Barometric Relief Dampers	45	20
Horizontal Barometric Relief Dampers	20	9
Outdoor Air Dampers		
Damper Section (downflow) Motorized	72	33
Damper Section (downflow) Manual	68	31
Outdoor Air Hood (downflow)	76	34
Power Exhaust		
Standard Static	99	45
50% High Static	460	209
100% High Static with or without VFD	525	238
ELECTRIC HEAT		
30 KW	59	27
45 KW	76	34
60 KW	76	34
90 KW	84	38
120 KW	98	44
HUMIDITROL® DEHUMIDIFICATION SYSTEM		
Humiditrol® Dehumidification Option (Net Weight)	100	45
PACKAGING		
LTL Packaging (less than truck load)	300	136
ROOF CURBS		
Hybrid Roof Curbs, Downflow		
14 in. height	115	52
18 in. height	140	64
24 in. height	170	77
Standard Curbs, Horizontal		
30 in. height	445	202
41 in. height	725	329

DIMENSIONS - UNIT

CORNER WEIGHTS

Model No.	CORNER WEIGHTS								CENTER OF GRAVITY			
	AA		BB		CC		DD		EE		FF	
	lbs.	kg	lbs.	kg	lbs.	kg	lbs.	kg	in.	mm	in.	mm
LCH242 Base Unit	610	277	612	278	880	399	895	406	60	1524	37	940
LCH242 Max. Unit	693	315	696	316	1001	454	1018	462	60	1524	37	940
LCH300 Base Unit	610	277	612	278	880	399	895	406	60	1524	37	940
LCH300 Max. Unit	693	315	696	316	1001	454	1018	462	60	1524	37	940
LCH360 Base Unit	610	277	612	278	880	399	895	406	60	1524	37	940
LCH360 Max. Unit	693	315	696	316	1001	454	1018	462	60	1524	37	940

Base Unit - The unit with NO INTERNAL OPTIONS.

Max. Unit - The unit with ALL INTERNAL OPTIONS Installed. (Economizer, Standard Static Power Exhaust, Controls, etc.). Does not include accessories external to unit or high static power exhaust.

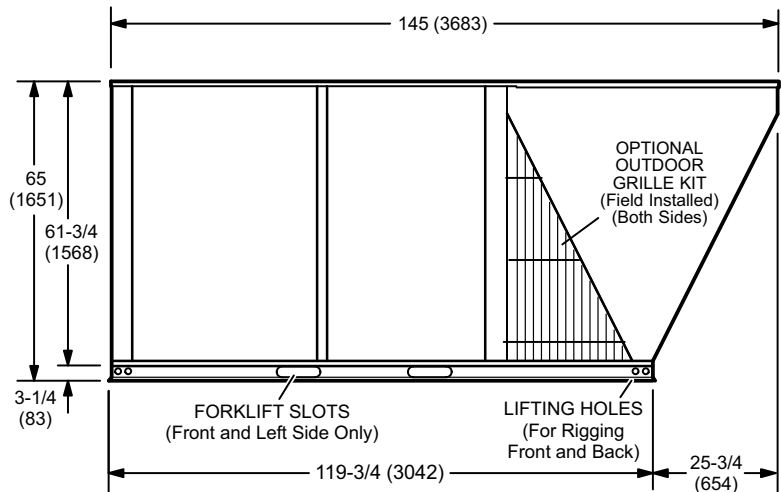
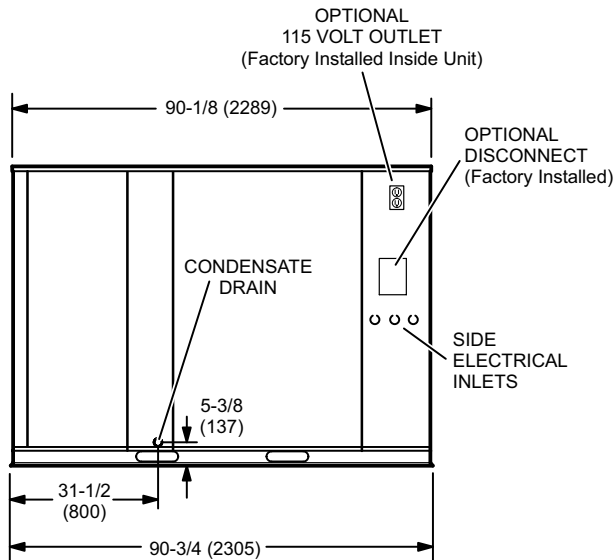
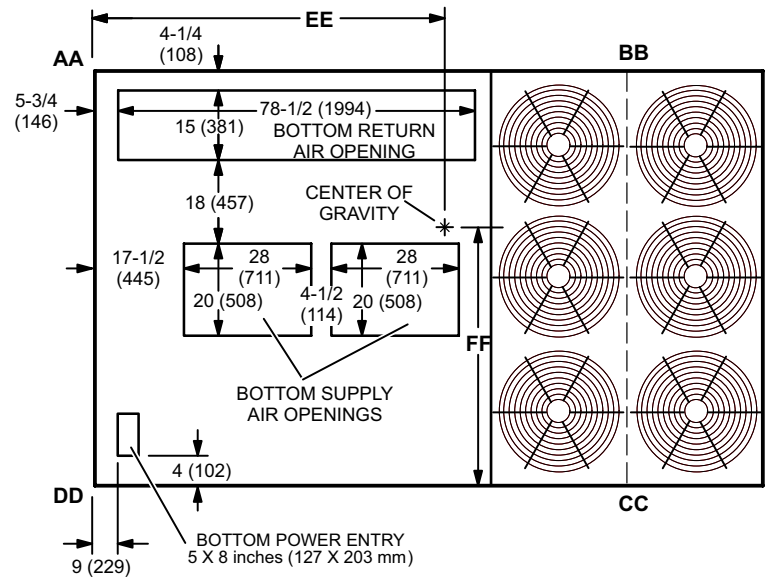

OUTDOOR AIR HOOD DETAIL

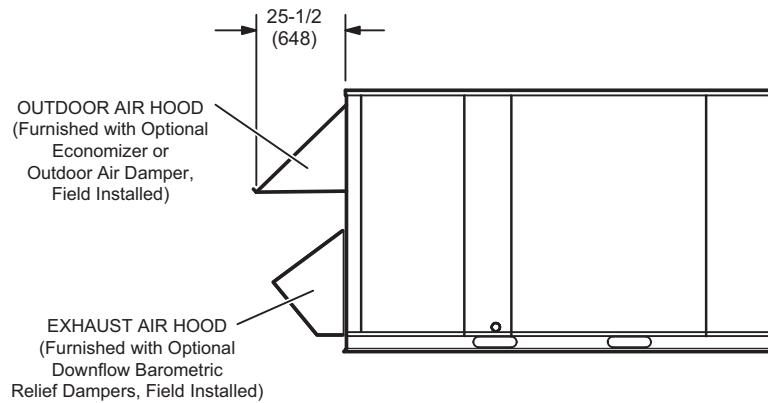

OPTIONAL HIGH STATIC POWER EXHAUST FANS DETAIL

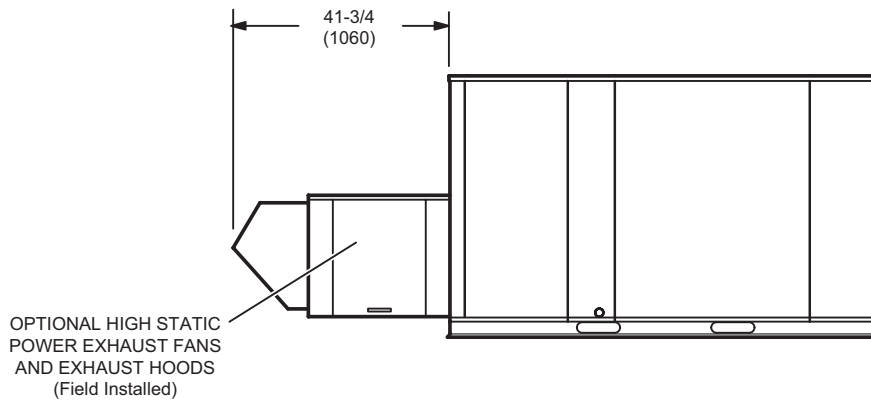

OPTIONAL HORIZONTAL BAROMETRIC RELIEF DAMPERS WITH HOOD

(Field installed in horizontal return air duct adjacent to unit)

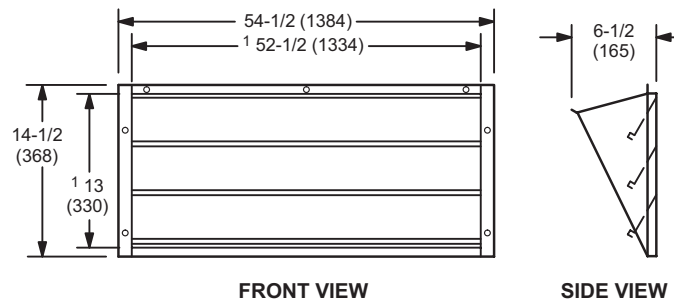

NOTE - Two furnished per order no.
¹ NOTE - Opening size required in return air duct.

DIMENSIONS - ACCESSORIES

HYBRID ROOF CURBS - DOUBLE DUCT OPENING

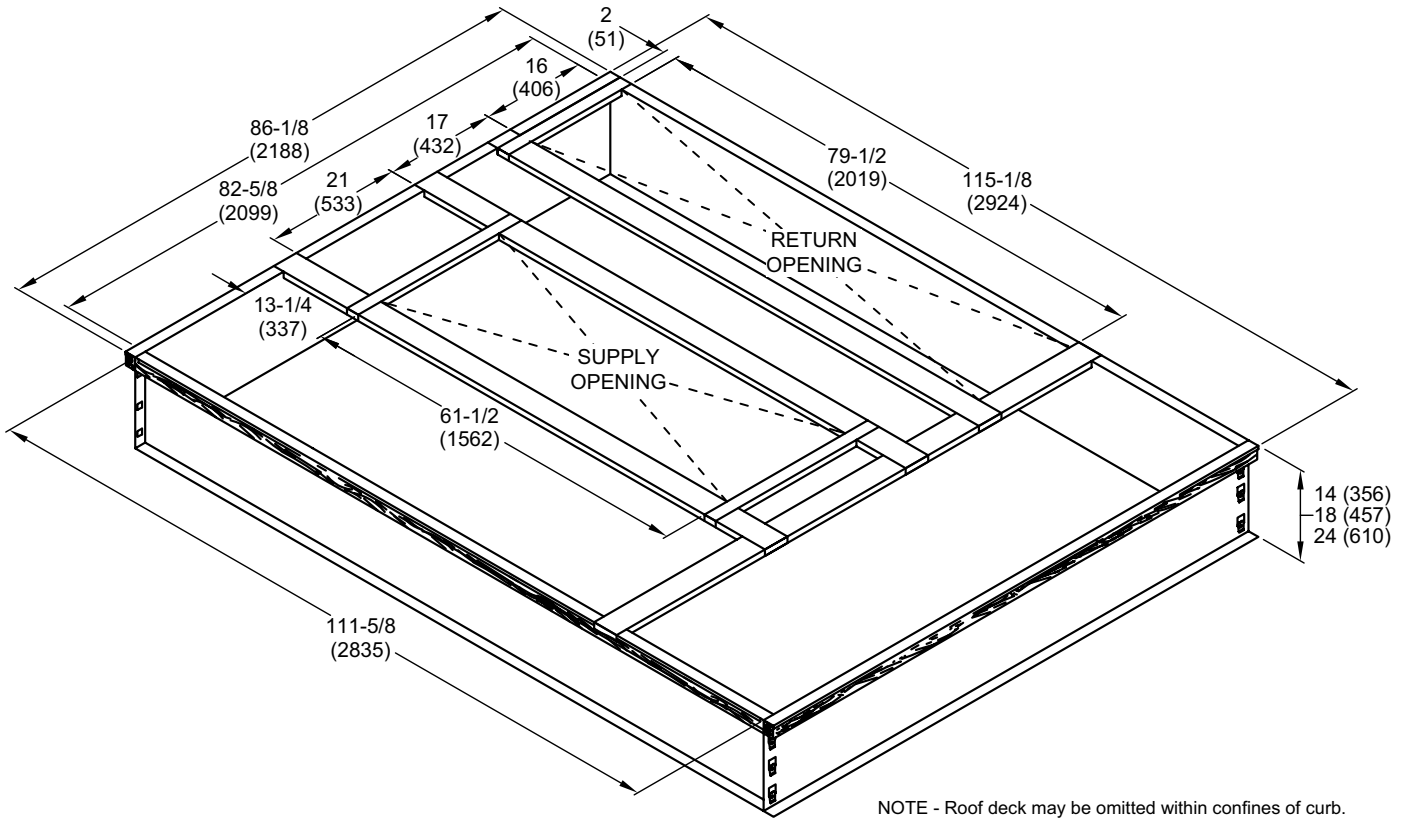

TYPICAL FLASHING DETAIL FOR ROOF CURB

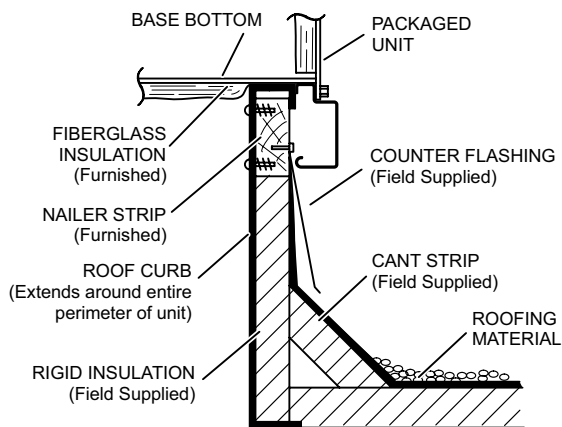

DETAIL ROOF CURB

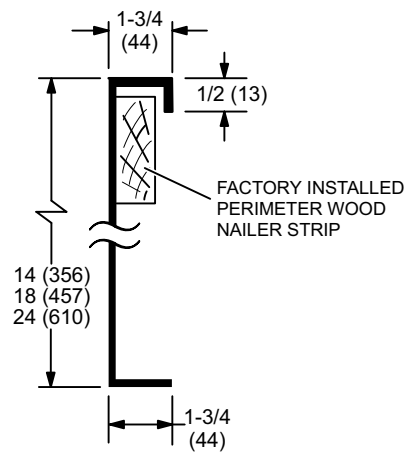

ROOF CURBS WITH SUPPLY & RETURN AIR TRANSITIONS FOR CEILING DIFFUSERS

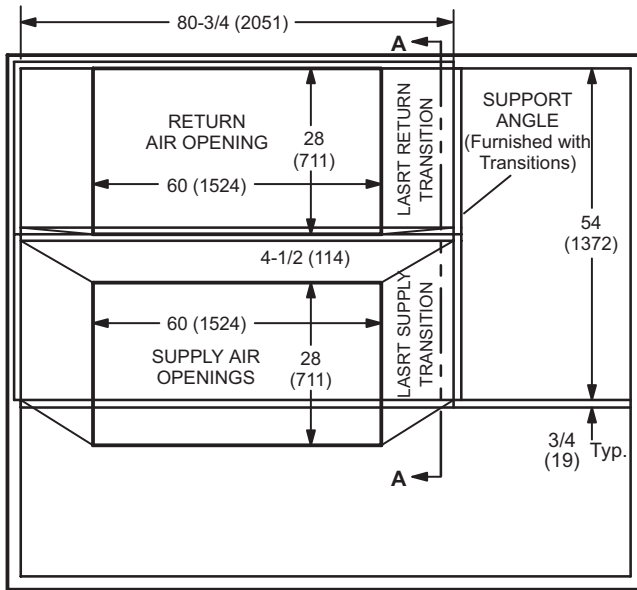

TOP VIEW

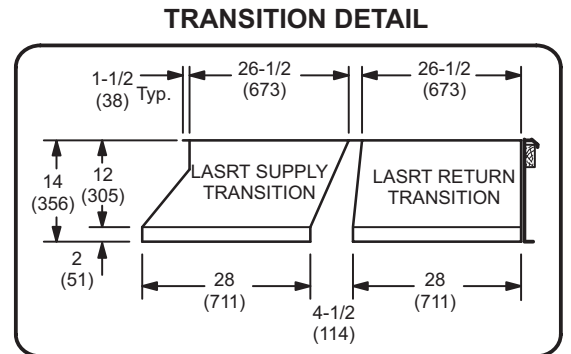

SECTION B-B

DIMENSIONS - ACCESSORIES

HORIZONTAL ROOF CURBS – Requires Optional Horizontal Return Air Panel Kit

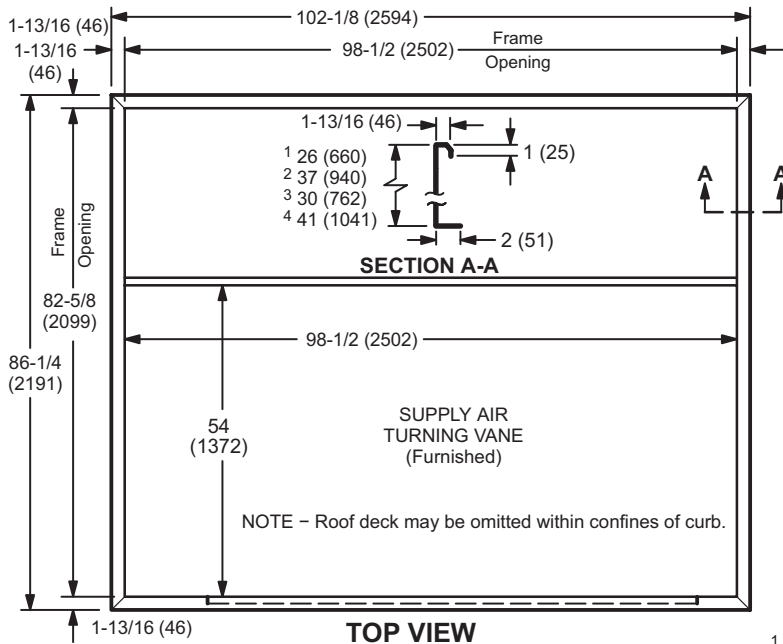

NOTE - 30 in. (762 mm) height Curb is designed for horizontal discharge when unit is mounted on a slab.
41 in. (1041 mm) height Curb is designed for horizontal discharge when unit is mounted on a rooftop.

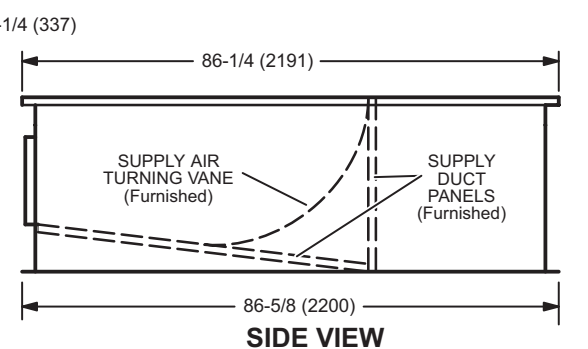
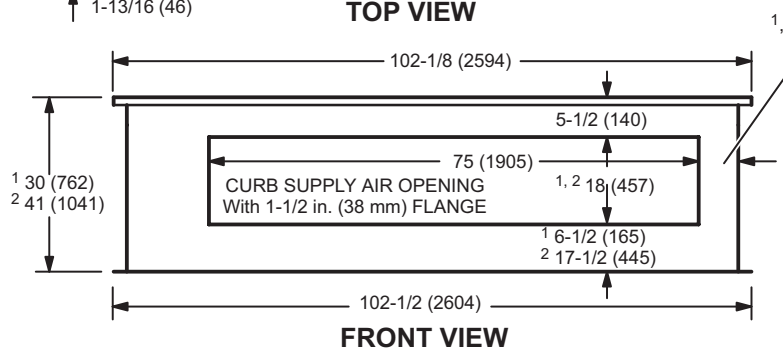
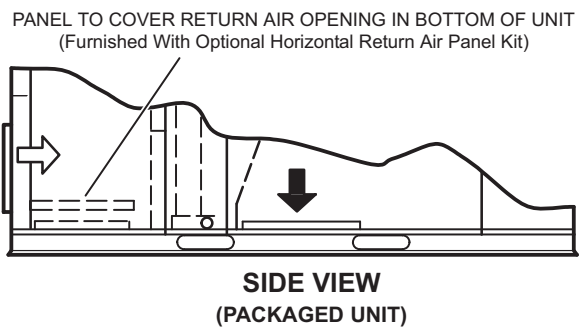

¹ Slab Applications ² Rooftop Applications

HORIZONTAL SUPPLY AND RETURN AIR OPENINGS ROOFTOP UNIT WITH HORIZONTAL ROOF CURB

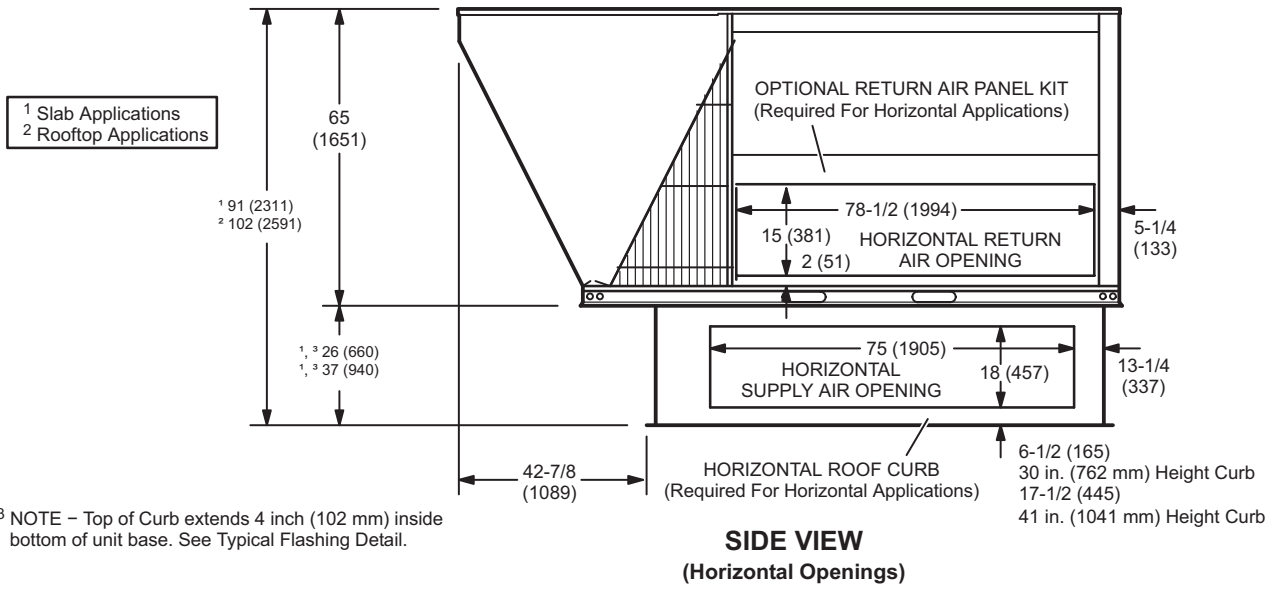

DIMENSIONS - ACCESSORIES

COMBINATION CEILING SUPPLY AND RETURN DIFFUSERS

STEP-DOWN CEILING DIFFUSER

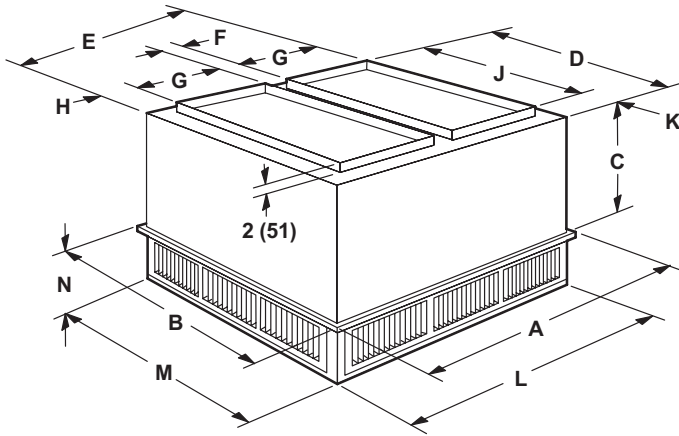

FLUSH CEILING DIFFUSER

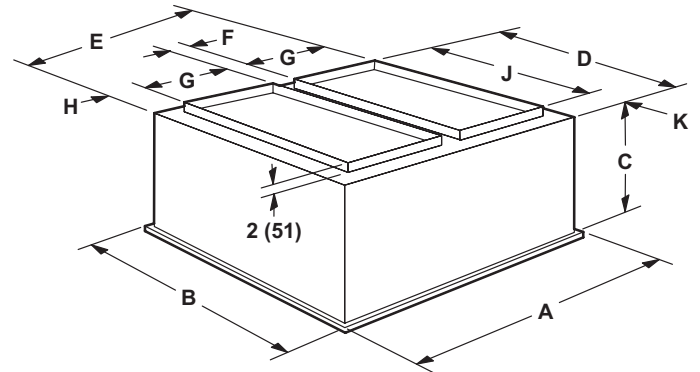

Model Number		LARTD30/36S
A	in.	65-5/8
	mm	1667
B	in.	65-5/8
	mm	1667
C	in.	40-1/2
	mm	1029
D	in.	63-1/2
	mm	1613
E	in.	63-1/2
	mm	1613
F	in.	4-1/2
	mm	114
G	in.	28
	mm	711
H	in.	1-1/2
	mm	38
J	in.	60
	mm	1524
K	in.	1-3/4
	mm	44
L	in.	63-1/2
	mm	1613
M	in.	63-1/2
	mm	1613
N	in.	12-1/8
	mm	308
Duct Size	in.	28 x 60
	mm	711 x 1524

Model Number		LAFD30/36S
A	in.	65-5/8
	mm	1667
B	in.	65-5/8
	mm	1667
C	in.	40
	mm	1016
D	in.	63-1/2
	mm	1613
E	in.	63-1/2
	mm	1613
F	in.	4-1/4
	mm	108
G	in.	28
	mm	711
H	in.	1-5/8
	mm	32
J	in.	60
	mm	1524
K	in.	1-3/4
	mm	44
Duct Size	in.	28 x 60
	mm	711 x 1524

REVISIONS

Sections	Description of Change
Options/Accessories	Catalog numbers revised for: Blower Proving Switch Condensate Drain Trap Drain Pan Overflow Switch Fresh Air Tempering Single Enthalpy



Visit us at www.lennox.com

For the latest technical information, www.lennoxcommercial.com

Contact us at 1-800-4-LENNOX

NOTE - Due to Lennox' ongoing commitment to quality, Specifications, Ratings and Dimensions subject to change without notice and without incurring liability. Improper installation, adjustment, alteration, service or maintenance can cause property damage or personal injury. Installation and service must be performed by a qualified installer and servicing agency.

©2021 Lennox Industries, Inc.