



**COMMERCIAL  
PRODUCT SPECIFICATIONS**

Bulletin No. 210933  
April 2021  
Supersedes March 2021



SMARTWIRE™ SYSTEM



**ASHRAE 90.1  
COMPLIANT**

**7.5 to 12.5 Tons  
Net Cooling Capacity - 86,000 to 138,000 Btuh  
Optional Electric Heat - 7.5 to 60 kW**

**MODEL NUMBER IDENTIFICATION**

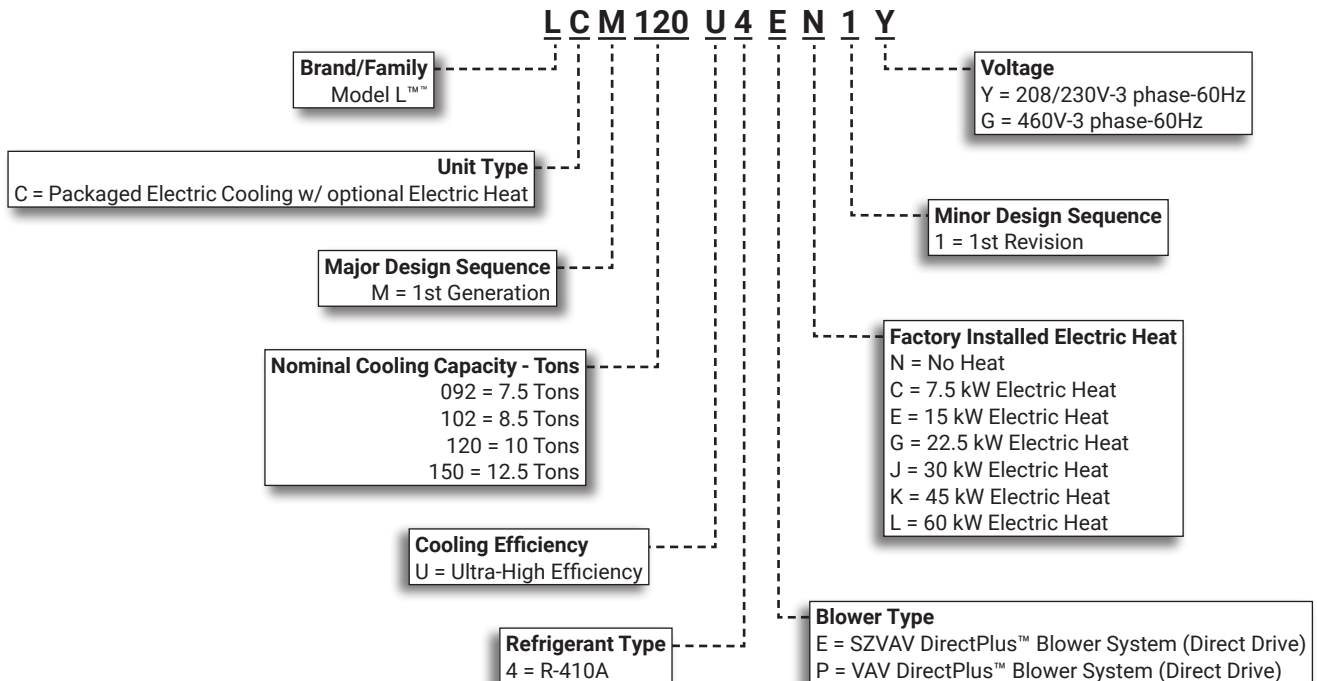

## FEATURE HIGHLIGHTS

The Model L™ packaged rooftop line is engineered with advanced variable speed technology to offer some of the highest energy efficiencies in the industry while delivering superior temperature and humidity control in a wide variety of commercial applications.

1. Variable Capacity Scroll Compressor and Fixed Capacity Scroll Compressor
2. Condenser Coil
3. Variable-Speed ECM Outdoor Coil Fan Motors
4. Heavy Gauge Steel Cabinet
5. Hinged Access Panels
6. DirectPlus™ Direct Drive ECM Blower System
7. Electric Heat (option)
8. Air Filters
9. Lennox® CORE Control System
10. Humiditrol™+ Dehumidification System (option)

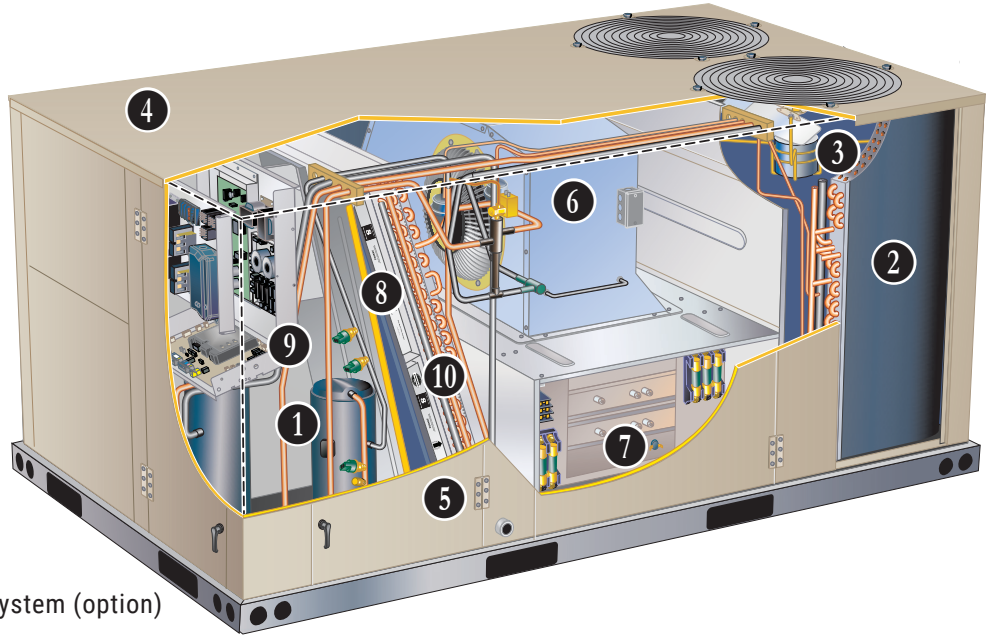

## CONTENTS

Approvals And Warranty . . . . .	3
Blower Data . . . . .	24
Control System . . . . .	7
Cooling Ratings . . . . .	21
Dimensions . . . . .	34
- Unit . . . . .	34
- Accessories . . . . .	35
Electrical/Electric Heat Data . . . . .	27
- 7.5 Ton . . . . .	27
- 8.5 Ton . . . . .	28
- 10 Ton . . . . .	29
- 12.5 Ton . . . . .	30
Features And Benefits . . . . .	3
Humiditrol™+ Dehumidification System Option . . . . .	11
Humiditrol™+ Dehumidification System Ratings . . . . .	23
Model Number Identification. . . . .	1
Optional Conventional Temperature Control Systems . . . . .	12
Options / Accessories . . . . .	17
Outdoor Sound Data . . . . .	31
Sequence Of Operation. . . . .	14
Specifications . . . . .	20
- Unit . . . . .	20
Unit Clearances . . . . .	31
Weight Data . . . . .	32
- Unit . . . . .	32
- Options / Accessories. . . . .	32

## APPROVALS AND WARRANTY

### APPROVALS

- AHRI Standard 340/360 certified
- ETL and CSA listed
- CSA certified energy ratings
- Unit and components ETL, NEC and CEC bonded for grounding to meet safety standards for servicing
- All models are ASHRAE 90.1-2010 energy efficiency compliant and meet or exceed requirements of Section 6.8
- All models meet DOE 2018 energy efficiency standards
- All models meet California Code of Regulations, Title 24 and ASHRAE 90.1-2010 Section 6.4.3.10 requirements for staged airflow
- ENERGY STAR® certified
- ISO 9001 Registered Manufacturing Quality System

### WARRANTY

- Compressors - Limited five years
- Lennox® CORE Unit Controller - Limited three years
- Optional High Performance Economizers - Limited five years
- All other covered components - Limited one year

## FEATURES AND BENEFITS

### COOLING SYSTEM

- Designed to maximize sensible and latent cooling performance at design conditions
- System can operate from 0°F to 125°F without any additional controls

#### **R-410A Refrigerant**

- Non-chlorine based
- Ozone friendly

#### **1 Dual Compressors**

Cooling system consists of one variable capacity scroll compressor and one fixed capacity scroll compressor

#### **Variable Capacity Scroll Compressor**

- High performance, reliability and quiet operation
- Operates on a variable frequency determined to vary capacity based on the cooling load required

#### **Fixed Capacity Scroll Compressor**

- High performance, reliability and quiet operation
- Resiliently mounted on rubber grommets for quiet operation

#### **Compressor Crankcase Heaters**

- Protects against refrigerant migration that can occur during low ambient operation or during extended off cycles

#### **DC Inverter Control (for Variable Capacity Compressor)**

- Converts AC line voltage into filtered variable DC voltage
- Provides continuous compressor operation, while adjusting the capacity according to discharge air temperature
- Adjusts compressor output in increments as small as 1%
- Prevents frequent changes in capacity and ensures efficient, economical operation

- Power Factor Correction (PFC) circuit monitors the DC bus for high, low and abnormal voltage conditions to protect the compressor
- Two LEDs (red and green) indicate inverter operating status and aid in troubleshooting
- Noise filter reduces unwanted electromagnetic interference (EMI)
- Inverter reactor adds inductance to the line between the inverter and the compressor to limit current rise and protect the compressor

#### **Thermal Expansion Valves**

- Ensures optimal performance throughout the application range
- Removable element head

#### **Filter/Driers**

- High capacity filter/drier protects the system from dirt and moisture

#### **High Pressure Switches**

- Protects the system from high pressure conditions

#### **Low Pressure Switches**

- Protects the compressors from low pressure conditions such as low refrigerant charge, or low/no airflow

#### **Diagnostic and Sensor System**

- Multiple thermistors continuously monitor the refrigeration system, providing optimum performance and complete circuit protection at all operating conditions

#### **Indoor Coil Freeze Protection**

- Protects the evaporator coil from damaging ice build-up due to conditions such as low/no airflow, or low refrigerant charge

## FEATURES AND BENEFITS

### COOLING SYSTEM (continued)

- 2** **Condenser Coil**
- Copper tube construction
  - Enhanced rippled-edge aluminum fins
  - Flared shoulder tubing connections
  - Silver soldered construction

#### **Evaporator Coil**

- Copper tube construction
- Enhanced rippled-edge aluminum fins
- Flared shoulder tubing connections
- Silver soldered construction
- Cross row circuiting with rifled copper tubing

#### **Anti-Microbial Condensate Drain Pan**

- Plastic pan, sloped to meet drainage requirements per ASHRAE 62.1
- Anti-Microbial additive resists growth of mold and mildew on drain pan, which improves indoor air quality and reduces drain line blockage
- Side or bottom drain connections
- Reversible to allow connection at back of unit

**3** **Variable-Speed ECM Outdoor Coil Fan Motors**

- Fan speed is directly controlled by the Lennox® CORE Unit Controller
- Thermal overload protected
- Totally enclosed
- Permanently lubricated ball bearings
- Shaft up
- Wire basket mount

#### **Outdoor Coil Fans**

- PVC coated fan guard furnished

#### **Options/Accessories**

#### **Factory or Field Installed**

##### **Condensate Drain Trap**

- Constructed of PVC (factory or field) or copper (field only)

**NOTE** - Trap is field installed only; PVC version may be factory ordered to ship with unit.

##### **Drain Pan Overflow Switch**

- Monitors condensate level in drain pan
- Shuts down unit if drain becomes clogged

### CABINET

- 4** **Construction**
- Heavy-gauge steel panels
  - Full perimeter heavy-gauge galvanized steel base rail
  - Base rails have rigging holes
  - Three sides of the base rail have forklift slots
  - Raised edges around duct and power entry openings in the bottom of the unit for water protection

#### **Airflow Choice**

- Units are shipped in downflow (vertical) configuration

**NOTE** - Units can be field converted to horizontal airflow with optional Horizontal Discharge Kit.

#### **Duct Flanges**

- Provided for horizontal duct attachment

#### **Power Entry**

- Electrical lines can be brought through the unit base or through horizontal access knock-outs

#### **Exterior Panels**

- Constructed of heavy-gauge, galvanized steel
- Textured pre-paint with polyurethane finish
- Cyclic salt fog and UV exposure up to 1680 hours per ASTM D5894

#### **Insulation**

- Fully insulated with non-hygroscopic fiberglass insulation (conditioned areas)
- Unit base is fully insulated
- Base insulation serves as an air seal to the roof curb, eliminating the need to add a seal during installation

**5** **Hinged Access Panels**

- Tool-less access
- Filter section
- Blower/heating section
- Compressor/controls section
- Panel seals and quarter-turn latching handles provide a tight air and water seal

#### **Required Selections**

#### **Airflow Configuration**

- Specify downflow or horizontal

#### **Options/Accessories**

#### **Factory or Field Installed**

##### **Return Air Adaptor Plate**

- For same size LC/LG/LH and TC/TG/TH unit replacement
- Installs on return air opening in unit to match return air opening on existing roof curbs
- Also see Accessory Air Resistance table

## FEATURES AND BENEFITS

### **CABINET (continued)**

#### Options/Accessories (continued)

#### **Factory Installed**

##### **Corrosion Protection**

- Completely flexible immersed coating
- Electrodeposited dry film process
- AST ElectroFin E-Coat
- Meets Mil Spec MIL-P-53084, ASTM B117 Standard Method Salt Spray Testing
- Indoor Corrosion Protection:
  - Coated coil
  - Coated reheat coil (Humiditrol™+)
  - Painted blower housing
  - Painted base
- Outdoor Corrosion Protection:
  - Coated coil
  - Painted outdoor base

#### **Field Installed**

##### **Combination Coil/Hail Guards**

- Heavy gauge steel frame
- Painted to match cabinet
- Expanded metal mesh protects outdoor coil

##### **Horizontal Discharge Kit**

- Consists of duct covers to block off downflow supply and return air openings for horizontal applications
- Also includes return air duct flanges for end return air when Economizer is used in horizontal applications

**NOTE** - When configuring unit for horizontal application with Economizer, a separate Horizontal Barometric Relief Damper with Hood must be ordered separately for installation in the return air duct.

### **BLOWER**

#### **6 DirectPlus™ Direct Drive ECM Blower System**

- High-efficiency, variable-speed ECM (electronically commutated) motor
- Eliminates the need for a separate variable-frequency drive
- SZVAV equipped models modulate the amount of supply blower airflow according to cooling demand, heating demand, ventilation demand or smoke alarm
- The amount of airflow for each stage can be set according to a parameter in the Lennox® CORE Unit Controller
- Unit is shipped from the factory with preset airflows
- Fully variable speed motor modulates to maximize system efficiency
- Combines the motor and electronics into one unit
- Aerodynamically optimized impeller



- Backward curved blades mounted directly onto the rotor
- Air inlet grill reduces indoor sound levels without affecting air performance

#### **Supply Static Pressure Transducer (VAV Models Only)**

- Sends information to the Lennox® CORE Unit Controller to control blower speed to the desired supply duct static pressure
- Shipped with the unit for remote field installation in the supply duct

#### **Required Selections**

##### **Blower Selection**

- SZVAV (Single Zone Variable Air Volume) controls the speed of the blower based on the cooling and heating demands
- VAV (Variable Air Volume) blower varies the air volume to maintain a constant supply duct static pressure

### **ELECTRICAL**

#### **SmartWire™ System**

- Keyed and color-coded wiring connectors prevent miswiring
- Wire coloring scheme is standardized across all models
- Each connection is intuitively labeled to make troubleshooting and servicing quick and easy

#### **Electrical Plugs**

- Positive connection electrical plugs are used to connect common accessories or maintenance parts for easy removal or installation

#### **Phase/Voltage Detection**

- Monitors power supply to ensure phase is correct at unit start-up
- If phase is incorrect, the unit will not start and an alarm code is reported to the unit controller
- Protects unit from being started with incorrect phasing which could lead to issues such as compressors running backwards
- Voltage detection monitors power supply voltage to ensure proper voltage
- If voltage is not correct (over/under voltage conditions) the unit will not start and an alarm code is reported to the unit controller

#### **Required Selections**

##### **Voltage Choice**

- Specify when ordering base unit

## FEATURES AND BENEFITS

### ELECTRICAL (continued)

#### Options/Accessories

#### **Factory Installed**

##### Circuit Breakers

- HACR type
- Overload and short circuit protection
- Factory wired and mounted in the power entry panel
- Current sensitive and temperature activated
- Manual reset

#### **Factory Installed**

##### Short-Circuit Current Rating (SCCR)

- Higher short-circuit protection up to 100kA

**NOTE** - Disconnect Switch not available with higher SCCR option. Short-Circuit Current Rating option not available on field installed electric heat.

#### **Factory or Field Installed**

##### Disconnect Switch

- Accessible outside of unit
- Spring loaded weatherproof cover furnished

### 7 Electric Heat

- Helix wound nichrome elements
- Individual element limit controls
- Wiring harness
- Unit fuse block
- See Options/Accessories tables for ordering information

##### GFI Service Outlets (2)

- 115V ground fault circuit interrupter (GFCI) type
- Non-powered, field-wired

#### **Field Installed**

##### GFI Weatherproof Cover

- Single-gang cover
- Heavy-duty UV-resistant polycarbonate case construction
- Hinged base cover with gasket

### INDOOR AIR QUALITY

### 8 Air Filters

- Disposable 2-inch filters furnished as standard

#### Options/Accessories

#### **Factory or Field Installed**

##### Healthy Climate® High Efficiency Air Filters

- Disposable MERV 8, MERV 13 or MERV 16 (Minimum Efficiency Reporting Value based on ASHRAE 52.2) efficiency 2-inch pleated filters

### Healthy Climate® UVC Germicidal Lamps

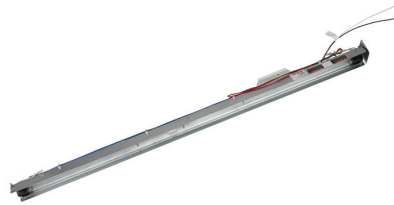

- Germicidal lamps emit ultra-violet (UV-C) energy, which has been proven to be effective in reducing microbes such as viruses, bacteria, yeasts, and molds
- This process either destroys the organism or controls its ability to reproduce
- UV-C energy greatly reduces the growth and proliferation of mold and other bioaerosols (bacteria and viruses) on illuminated surfaces (particularly coil and drain pan)
- Installed in the blower/evaporator coil section
- Safety interlock switch automatically shuts off power to the UVC light when panel is removed
- Interlock switch is factory installed or field installed in the blower/evaporator coil section panel
- All necessary hardware for installation is included
- Lamps operate on 110/230V, 1 phase power supply

**NOTE** - For 460V units, field installed lamps utilize jumpers to the outdoor fan transformer for voltage needed. See the installation Instructions.

- Approved by ETL

#### **Needlepoint Bipolar Ionization (NPBI) Kit**

- NPBI technology integrates with system controls for effective air treatment
- Ionization has been shown to effectively reduce harmful pathogens, pollutants and odors

**NOTE** - Please visit [www.sciencedirect.com](http://www.sciencedirect.com) for additional information.

- Brush-type ionizer introduces a high concentration of both positive and negative ions into the airstream
- These bipolar ions are then dispersed into the occupied space through the duct system proactively reducing the airborne contaminants
- Ions travel within the building air stream and attach to particles, pathogens, and gas molecules, making them larger and easier to capture in the filtration system
- UL 2998 certified for zero ozone emission

#### **Field Installed**

##### Indoor Air Quality (CO<sub>2</sub>) Sensors

- Monitors CO<sub>2</sub> levels, reports to the Lennox® CORE Unit Controller which adjusts Economizer dampers as needed

##### Replacement Filter Media Kit With Frame

- Replaces existing pleated filter media
- Includes washable metal mesh screen and metal frame with clip for holding replaceable non-pleated filter

## CONTROL SYSTEM

### LENNOX® CORE CONTROL SYSTEM

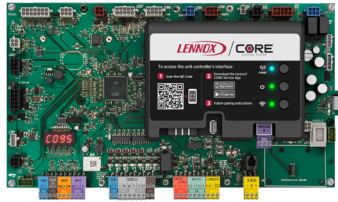

The Lennox® CORE Control System is designed to accelerate equipment install and service. Standard with all Model L™ rooftop units, control system integrates key technologies that lower installation costs, drive system efficiency, and protect your investments.

**9** The Lennox® CORE Unit Controller is a microprocessor-based controller that provides flexible control of all unit functions.

#### Wireless Service App Connectivity (Coming Soon to Android and iOS)

- Setup menu ensures proper installation and simplified setup of the rooftop unit
- Detailed data readout updates sensor values in real time and allows trending
- Unit self-test verifies individual critical component and system performance
- Economizer test function ensures Economizer is operating correctly



**NOTE** - Android or iOS device required.

#### Additional Features:

- Built-In 7-Segment Display shows Unit Status and active alarms for easy troubleshooting
- Buttons for test and clearing delays
- SmartWire™ System with keyed and removable screw terminals ensure correct field wiring
- Built-in BACnet MS/TP and IP allow open integration to building management systems.
- Two-port Ethernet Switch enables daisy chaining for BACnet IP and automatic firmware updates

**NOTE** - Unit Internet Connection required.

- Profile setup copies key settings between units with the same configuration to reduce setup time
- USB port allows a technician to download and transfer unit information to help verify service was performed
- USB software updates on the Lennox® CORE Unit Controller enhance functionality without the need to change components
- Unit Controller Software

#### Configurable Built-In Functions

- Full modulation of variable speed compressor for discharge air temperature control in room sensor or thermostat mode
- Discharge Air Cooling Control (Standard)
- Up to three distinct Cooling Airflows in Thermostat Mode with additional relay.
- Programmable independent heating, ventilation and cooling blower speeds

- Discharge Air Heating Control
- Economizer Control Options (See Economizer / Exhaust Air / Outdoor Air sections)
- Exhaust Fan Control Modes for fresh air damper position
- Configurable Morning Warm-up
- Night Setback Mode
- Fresh Air Tempering for Improved Ventilation
- Demand Control Ventilation
- Low Ambient Controls for operation down to 0°F
- Humiditrol™+ Operation (Variable Capacity Hot-Gas Reheat)
- Enhanced Dehumidification (Latent Demand Control without reheat)

#### Component Protection / Unit Safeguards:

- Compressor Time-Off Delay
- Adjustable Blower On/Off Delay
- Return Air Temperature Limit Control
- Safety Switch Input allows Controller to respond to a external safety switch trip
- Service Relay Output
- Thermostat Bounce Delay
- Smoke Alarm Mode has four choices (unit off, positive pressure, negative pressure, purge)
- “Strike Three” Protection
- Gas Valve Time Delay Between First and Second Stage
- Minimum Compressor Run Time

#### Control Methods / Interfaces:

- DDC and 24V Thermostat
- BACnet MS/TP and IP
- LONTalk (Factory and Field Option)
- Lennox SBUS
- Compatibility with Lennox Wireless Room Sensors
- Zone Temperature Sensor Input
- Dehumidistat and Humidity Sensor Inputs
- Indoor Air Quality Inputs (2)
- Built-in Control Parameter Defaults
- Permanent Diagnostic Code Storage
- Field Adjustable Control Parameters (Over 200 settings)
- Multiple Configurable Digital Inputs
- LED Indicators
- PC Interface connects the Lennox® CORE Unit Controller to a PC with the Lennox Unit Controller Software

**NOTE** - Lennox® CORE Control System features vary with the type of rooftop unit in which the control is installed.

## CONTROL SYSTEM

### LENNOX® CORE CONTROL SYSTEM (continued)

#### Controls Options

##### Factory or Field Installed

##### Blower Proving Switch

- Monitors blower operation, shuts down unit if blower fails

##### Dirty Filter Switch

- Senses static pressure increase and issues alarm if necessary

##### Fresh Air Tempering

- Used in applications with high outside air requirements
- Controller energizes the first stage heat as needed to maintain a minimum supply air temperature for comfort, regardless of the thermostat demand
- When ordered as a factory option, sensor ships with the unit for field installation

##### Smoke Detector

- Photoelectric type
- Installed in supply air section, return air section or both sections
- Available with power board and single sensor (supply or return) or power board and two sensors (supply and return)
- Power board located in unit control compartment

##### Interoperability via BACnet® or LonTalk® Protocols

- Communication compatible with third-party automation systems that support the BACnet Application Specific Controller device profile, LonMark® Space Comfort Controller functional profile, or LonMark Discharge Air Controller functional profile

### COMMERCIAL CONTROL SYSTEMS

#### (Field Installed)

##### L Connection® Network Control System

- Complete building automation control system for single or multi-zone applications
- Options include local interface, software for local or remote communication, and hardware for networking other control functions
- See L Connection Network Control System Product Specifications Bulletin for details

##### After-Market DDC

- Novar® Unit Controller and options

##### Thermostats

- Control system and thermostat options, see page 12
- After-Market unit controller options

## OPTIONS / ACCESSORIES

### ECONOMIZER

- Economizer operation is set and controlled by the Lennox® CORE Unit Controller
- Simple plug-in connections from Economizer to unit controller for easy installation
- All Model L™ rooftop units are equipped with factory installed CEC Title 24 approved sensors for outside, return and discharge air temperature monitoring

**NOTE** - Optional sensors may be used instead of unit sensors to determine whether outdoor air is suitable for free cooling. See Options/Accessories table.

#### Factory or Field Installed

##### High Performance Economizer

- Approved for California Title 24 building standards
- Low leakage dampers are Air Movement and Control Association International (AMCA) Class 1A Certified - Maximum 3 CFM per sq. ft. leakage at 1 in. w.g.
- ASHRAE 90.1 and IECC compliant
- Downflow or Horizontal with Outdoor Air Hood
- Outdoor Air Hood is included when Economizer is factory installed and is furnished with Economizer when ordered for field installation
- Downflow Barometric Relief Dampers with Exhaust Hood is also furnished

**NOTE** - Horizontal economizer applications require optional Horizontal Low Profile Barometric Relief Dampers and Horizontal Discharge Kit.

- Gear-driven action
- High torque 24-volt fully-modulating spring return damper motor
- Return air and outdoor air dampers
- Plug-in connections to unit
- Stainless steel bearings
- Enhanced thermoplastic vulcanizate (TPV) seals
- Flexible stainless steel jamb seals

**NOTE** - High Performance Economizers are not approved for use with enthalpy controls in Title 24 applications.

**NOTE** - The Free Cooling setpoint for Title 24 applications must be set based on the Climate Zone where the system is installed. See Section 140.4 "Prescriptive Requirements for Space Conditioning Systems" of the California Energy Commission's 2019 Building Energy Efficiency Standards.

**NOTE** - Refer to Installation Instructions for complete setup information.



## OPTIONS / ACCESSORIES

### **ECONOMIZER (continued)**

#### **Factory or Field Installed (continued)**

##### **Differential Sensible Control**

- Factory setting
- Uses outdoor air and return air sensors that are furnished with the unit
- The Lennox® CORE Unit Controller compares outdoor air temperature with return air
- When the outdoor air is below the configured setpoint and cooler than return air, the controller activates the Economizer

**NOTE** - Differential Sensible Control can be configured in the field to provide Offset Differential Sensible Control or Single Sensible Control.

**NOTE** - In Offset Differential Sensible Control mode, the Economizer is enabled if the temperature differential (offset) between outdoor air and return air reaches the configured setpoint. In Single Sensible Control mode, the Economizer is enabled when outdoor air temperature falls below the configured setpoint.

##### **Global Control**

- The unit controller communicates with a DDC system with one global sensor (enthalpy or sensible)
- Determines whether outside air is suitable for free cooling on all units connected to the control system
- Sensor must be field provided

##### **Single Enthalpy Temperature Control (Not for Title 24)**

- Outdoor air enthalpy sensor enables Economizer if the outdoor enthalpy is less than the setpoint of the control

##### **Differential Enthalpy Control (Not for Title 24)**

- Order two Single Enthalpy Controls
- One is field installed in the return air section
- One is installed in the outdoor air section
- Allows the Economizer control to select between outdoor air or return air, whichever has lower enthalpy

#### **Field Installed**

##### **Horizontal Low Profile Barometric Relief Dampers**

- For use when unit is configured for horizontal applications requiring an Economizer
- Allows relief of excess air
- Aluminum blade dampers prevent blow back and outdoor air infiltration during off cycle
- Field installed in return air duct
- Bird screen and hood furnished

**NOTE** - Requires Horizontal Discharge Kit.

#### **Field Installed**

##### **Outdoor Air CFM Control**

- Maintains constant outdoor air volume levels on the supply air fan and varying unit airflows
- Velocity sensor located in the rooftop unit outdoor air section, the Lennox® CORE Unit Controller changes the Economizer position to help minimize the effect of supply fan speed changes on outdoor air volume levels
- Setpoint for outdoor air volume is established by field testing

**NOTE** - Not available with Demand Control Ventilation (CO<sub>2</sub> Sensor) or Building Pressure Control.

##### **Building Pressure Control**

- Maintains constant building pressure level
- Includes a static pressure transducer and outdoor static pressure assembly
- Using differential pressure information between the outdoor air and the building air, the Lennox® CORE Unit Controller changes the Economizer position to help maintain a constant building pressure

**NOTE** - Not available with Demand Control Ventilation (CO<sub>2</sub> Sensor) or Outdoor Air CFM Control.

#### **POWER EXHAUST**

##### **Factory or Field Installed**

##### **Power Exhaust Fan**

- Installs internal to unit for downflow applications only with Economizer option
- Provides exhaust air pressure relief
- Interlocked to run when supply air blower is operating
- Fan runs when outdoor air dampers are 50% open (adjustable)
- Motor is overload protected
- Fan is 20 in. diameter
- Five blades
- One 1/3 hp motor

**NOTE** - Requires Economizer with furnished Downflow Barometric Relief Dampers with Exhaust Hood.

## OPTIONS / ACCESSORIES

### **OUTDOOR AIR OPTIONS**

#### **Factory or Field Installed**

##### **Outdoor Air Damper**

- Downflow or Horizontal
- Linked mechanical dampers
- 0 to 25% (fixed) outdoor air adjustable
- Installs in unit
- Includes outdoor air hood
- Automatic model features fully modulating spring return damper motor with plug-in connection
- Manual model features parallel blade, gear-driven dampers with adjustable fixed position

#### **ROOF CURBS**

##### **Field Installed**

- Nailer strip furnished (downflow only)
- Mates to unit
- US National Roofing Contractors Approved
- Shipped knocked down

##### **Hybrid Roof Curbs, Downflow**

- Interlocking tabs fasten corners together
- No tools required
- Can also be fastened together with furnished hardware
- Available in 8, 14, 18, and 24 inch heights

##### **Adjustable Pitch Curb**

- Fully adjustable pitch curbs (3/4 in. per foot in any direction) provide a level platform for rooftop units allowing flexible installations on roofs with uneven or sloped angles
- Interlocking tabs fasten corners together
- No tools required
- Hardware is furnished to connect upper curb with lower curb
- Available in 14 inch height

##### **Adaptor Curbs (not shown)**

- Curbs are regionally sourced
- Dimensions vary based upon the source

**NOTE** - Contact your local sales representative for a detailed cut sheet with applicable dimensions.

### **CEILING DIFFUSERS**

#### **Field Installed**

##### **Ceiling Diffusers**

##### **(Flush or Step-Down)**

- White powder coat finish on diffuser face and grilles
- Insulated UL listed duct liner
- Diffuser box has collars for duct connection
- Step-down diffusers have double deflection blades
- Flush diffusers have fixed blades
- Provisions for suspending
- Internally sealed to prevent recirculation
- Removable return air grille
- Adapts to T-bar ceiling grids or plaster ceilings

##### **Transitions (Supply and Return)**

- Used with diffusers
- Installs in roof curb
- Galvanized steel construction
- Flanges furnished for duct connection to diffusers
- Fully insulated

## HUMIDITROL™ + DEHUMIDIFICATION SYSTEM OPTION

### OVERVIEW

- Factory installed option designed to control humidity
- 10 • Humiditrol + utilizes advanced control algorithms, variable speed technology and a reheat coil to efficiently control humidity levels independent of room temperature
- Provides dehumidification on demand using ASHRAE 90.1 recommended method for comfort conditioning humidity control
- Unit comes equipped with one row reheat coil and solenoid valve

**NOTE** - A dehumidification demand from a relative humidity sensor, dehumidistat, a DDC controller or building automation system is required to control humidity

### BENEFITS

- Improves indoor air quality
- Discharge air control for overcool protection
- Adjustable discharge air temperature setpoint
- Energy efficient dehumidification
- Modulating latent and sensible capacity
- Helps prevent damage due to high humidity levels
- Improves comfort levels by reducing space humidity levels

### OPERATION

#### No Dehumidification Demand

- The unit will operate conventionally whenever there is a demand for cooling or heating and no dehumidification demand
- Free cooling is only permitted when there is no demand for dehumidification

#### Dehumidification Demand Only

- Reheat operation will initiate on a dehumidification demand and does not require a cooling demand
- The unit will operate in hot gas reheat dehumidification mode until the relative humidity of the conditioned space is below the setpoint
- A solenoid valve diverts hot gas from the compressor to the reheat coil
- The cooled and dehumidified air from the evaporator is reheated as it passes through the reheat coil
- The de-superheated and partially condensed refrigerant continues to the outdoor condenser coil where condensing is completed
- Unit will continue to operate in this mode until the dehumidification demand is satisfied
- The reheat coil is sized to provide optimal reheat performance without overheating supply air
- The compressor will modulate based on dehumidification load

#### Dehumidification and Cooling Demand (Thermostat/ Room Sensor Application)

- If both a dehumidification and a cooling demand occur, the system will operate in cooling until the cooling demand is satisfied
- Then the system will energize the dehumidification mode

**NOTE** - See Sequence of Operation for additional information.

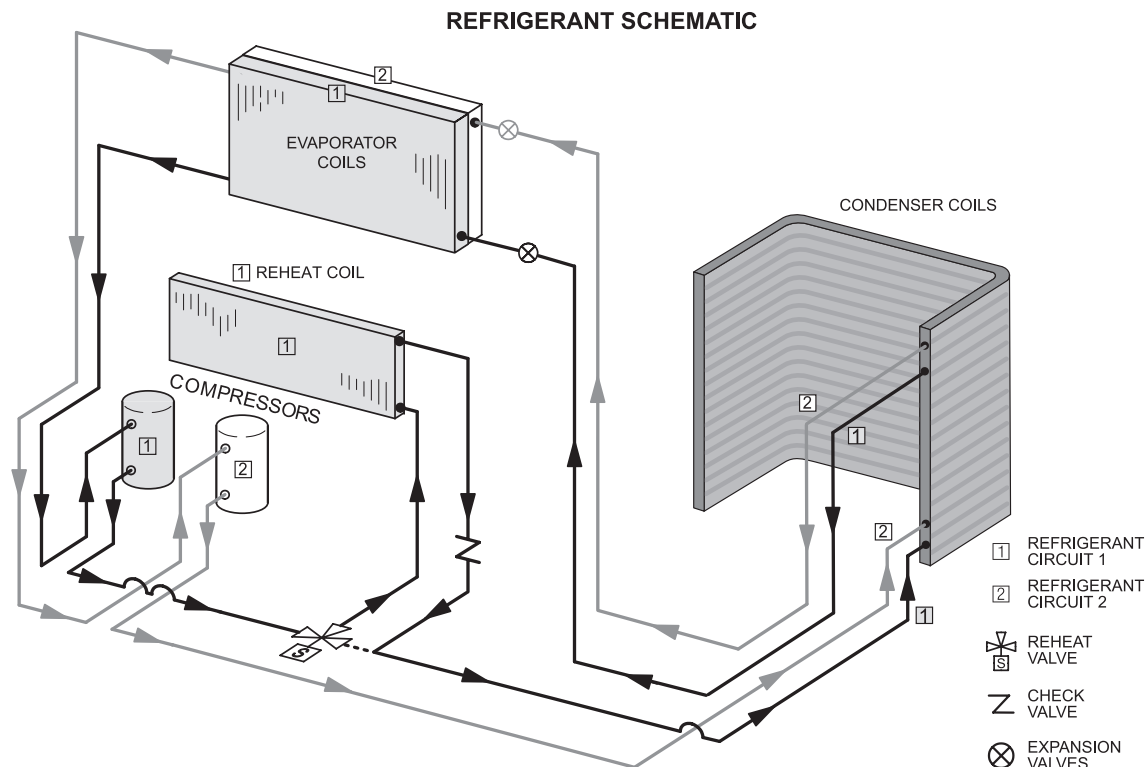

## OPTIONAL CONVENTIONAL TEMPERATURE CONTROL SYSTEMS

### ComfortSense® 8500 Commercial 7-Day Programmable Thermostat

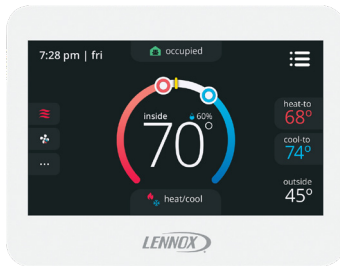

- Fully Communicating Sensor
- Full Color Touchscreen Interface
- Variable Speed System Control (On Compatible Units)
- Up To 4 Heat / 4 Cool
- Built-In Sensors For Temperature, Humidity And Optional CO<sub>2</sub>
- Remote Sensor Options For Occupancy, Temperature
- BACnet Capable Options
- 5-2 or 7-Day Scheduling
- Smooth Setback Recovery
- Heat/Cool Auto-Changeover
- Four-Wire Installation
- FDD, ASHRAE, IECC Compliant

### ComfortSense® 7500 Commercial 7-Day Programmable Thermostat



- Premium Universal Thermostat
- Full Color Touchscreen Interface
- Up To 4 Heat / 2 Cool
- Built-In Sensors For Temperature and Humidity
- Remote Sensors Options For Temperature, Discharge Air, Outdoor Air
- 5-2 or 7-Day Scheduling
- Smooth Setback Recovery
- Heat/Cool Auto-Changeover
- FDD, ASHRAE, IECC Compliant

### ComfortSense® 3000 Commercial 5-2 Day Programmable Thermostat



- Conventional Multi-Stage Thermostat
- Intuitive Display
- Push-Button Operation
- Up To 2 Heat / 2 Cool
- Built-In Temperature Sensor
- Remote Temperature Sensing
- Up to 5-2 Day Scheduling
- Smooth Setback Recovery
- Heat/Cool Auto-changeover

### Wireless/Wired Room Sensor (LCS-5030)



- Simple Push-Button Override
- Variable Speed System Control (On Compatible Units)
- Up To 4 Heat / 4 Cool
- Built-In Temperature and Humidity Sensors
- AA Battery / 24VAC Powered
- Bluetooth™ Mesh Operation
- SBUS Wired Operation
- Automatic Sensor Averaging
- Locking Hex Screw

### Wireless Repeater



- Extends Effective Range of Wireless Sensor
- 24VAC Only
- Locking Hex Screw

**NOTE** - Wireless only.

## OPTIONAL CONVENTIONAL TEMPERATURE CONTROL SYSTEMS

Description	Catalog No.
<b>ComfortSense® 8500 Commercial 7 Day Programmable Thermostat</b>	
CS8500 7-Day Thermostat	No CO <sub>2</sub> Sensing <b>17G75</b>
	With CO <sub>2</sub> Sensing <b>17G76</b>
Sensors/Accessories	<sup>1</sup> Remote non-adjustable wall-mount 10k <b>47W37</b>
	<sup>1</sup> Remote non-adjustable wall-mount 11k <b>94L61</b>
<b>Sysbus Network Cable (Yellow) for ComfortSense 8500 and LCS-5030 Wired Room Sensor</b>	
Twisted pair 100% shielded communication cable, Red and Black	500 ft. box <b>27M19</b>
22 AWG, yellow jacket, rated at 75°C, 300V, Plenum rated	1000 ft. box <b>94L63</b>
Insulation - Low smoke PVC, NEC, CMP	2500 ft. roll <b>68M25</b>
<b>ComfortSense® 7500 Commercial 7-Day Programmable Thermostat</b>	
CS7500 7-Day Thermostat	<b>17G74</b>
Sensors/Accessories	<sup>2</sup> Remote non-adjustable wall-mount 20k <b>47W36</b>
	<sup>2</sup> Remote non-adjustable wall-mount 10k <b>47W37</b>
	Remote non-adjustable discharge air (duct mount) <b>19L22</b>
	Outdoor temperature sensor <b>X2658</b>
<b>ComfortSense® 3000 Commercial 5-2 Day Programmable Thermostat</b>	
CS3000 5-2 Day Thermostat	<b>11Y05</b>
Sensors/Accessories	Remote non-adjustable wall mount 10k averaging <b>47W37</b>
	Thermostat wall mounting plate <b>X2659</b>
<b>ComfortSense® Non-Programmable Thermostat</b>	
CS3000 Non-Programmable Thermostat	<b>51M32</b>
<b>Universal Thermostat Guard with Lock (clear)</b>	
	Inside Dimensions (H x W) 5 7/8 x 8 3/8 in. <b>39P21</b>
<b>Wireless/Wired Room Sensor</b>	
LCS-5030 Wireless/Wired Room Sensor	<b>21L07</b>
	Wireless Repeater for Room Sensor - Temperature and humidity, no display <b>21L09</b>

<sup>1</sup> Up to nine of the same type remote temperature sensors can be connected in parallel.

<sup>2</sup> Remote wall-mount sensors can be applied in any of the following combinations:  
 One Sensor - (1) 47W36, Two Sensors - (2) 47W37, Three Sensors - (2) 47W36 and (1) 47W37  
 Four Sensors - (4) 47W36, Five Sensors - (3) 47W36 and (2) 47W37

## SEQUENCE OF OPERATION

### **COOLING**

#### **A-Two-Stage Thermostat**

1 - Economizer With Outdoor Air Suitable

##### **Y1 Demand**

- Compressors Off
- Blower Cooling Low
- Dampers Modulate

*NOTE - If dampers are at maximum open for five minutes, blower runs at cooling high.*

##### **Y2 Demand**

- Compressors Modulate
- Blower Cooling High
- Dampers Maximum Open

2 - No Economizer or Outdoor Air Not Suitable

##### **Y1 Demand**

- Compressors Modulate
- Blower Cooling Low
- Dampers Minimum Position

##### **Y2 Demand**

- Compressors Modulate
- Blower Cooling High
- Dampers Minimum Position

#### **B-Three-Stage Thermostat**

1 - Economizer With Outdoor Air Suitable

##### **Y1 Demand**

- Compressors Off
- Blower Cooling Low
- Dampers Modulate

*NOTE - If dampers are at maximum open for five minutes, blower runs at cooling intermediate.*

##### **Y2 Demand**

- Compressors Modulate
- Blower Cooling Intermediate
- Dampers Maximum Open

##### **Y3 Demand**

- Compressors Modulate
- Blower Cooling High
- Dampers Maximum Open

## SEQUENCE OF OPERATION

### **COOLING (CONTINUED)**

2 - No Economizer or Outdoor Air Not Suitable

#### **Y1 Demand**

- Compressors Modulate
- Blower Cooling Low
- Dampers Minimum Position

#### **Y2 Demand**

- Compressors Modulate
- Blower Cooling Intermediate
- Dampers Minimum Position

#### **Y3 Demand**

- Compressors Modulate
- Blower Cooling High
- Dampers Minimum Position

### **C - Room Sensor**

1 - Economizer With Outdoor Air Suitable

- Compressors Off
- Blower Modulates
- Dampers Modulate

*NOTE - If dampers are at maximum open for five minutes, compressors are energized and the blower modulates.*

2 - No Economizer or Outdoor Air Not Suitable

- Compressors Modulate
- Blower Modulates
- Dampers Minimum Position

*NOTE - Free cooling is locked out when a dehumidification demand is received. The unit operates in dehumidification mode as if the outdoor air is not suitable.*

### **HEATING**

**Heating Mode: Thermostat or Room Sensor (Up to 2 Stages)**

#### **W1 Demand**

1st stage of electric heat is energized and the supply fan operates at high speed.

#### **W2 Demand**

2nd stage of electric heat is energized and the supply fan operates at high speed.

## SEQUENCE OF OPERATION

### **HUMIDITROL™+**

#### **A - Thermostat Mode With 24V Humidistat**

Dehumidification Demand (DI4) and No Cooling Demand

Compressor operates at 100%, blower and outdoor fans modulate to maintain indoor coil and discharge air temperatures, reheat valve is energized.

##### **Y1 and DI4 Demand**

Compressors are modulating, blower is on low, and the reheat valve is de-energized.

##### **Y2 and DI4 Demand**

Compressors are modulating, blower is on high, reheat valve is de-energized.

#### **B - Thermostat Mode With Zone Relative Humidity Sensor**

Dehumidification Demand (Zone Relative Humidity is greater than the relative humidity setpoint) and No Cooling Demand

Compressor modulates based on zone relative humidity, blower and outdoor fans modulate to maintain indoor coil and discharge air temperatures, reheat valve is energized.

Y1 and Dehumidification Demand

Compressors are modulating, blower is on low, and the reheat valve is de-energized.

Y2 and Dehumidification Demand

Compressors are modulating, blower is on high, reheat valve is de-energized.

#### **C - Room Sensor Mode With Humidistat**

Dehumidification Demand (DI4) and No Cooling Demand

Compressor 1 operates at 100%, blower and outdoor fans modulate to maintain indoor coil and discharge air temperatures, reheat valve is energized.

Cooling and Dehumidification Demand

Compressors are modulating, blower is modulating, reheat valve is de-energized.

#### **D - Room Sensor Mode With Zone Relative Humidity Sensor**

Dehumidification Demand (Zone Relative Humidity is greater than the relative humidity setpoint) and No Cooling Demand

Compressor 1 modulates based on zone relative humidity, blower and outdoor fans modulate to maintain indoor coil and discharge air temperatures, reheat valve is energized.

Cooling and Dehumidification Demand

Compressors are modulating, blower is modulating, and the reheat valve is de-energized.



## OPTIONS / ACCESSORIES

Item Description	Catalog Number	Unit Model No				
		092	102	120	150	
<b>COOLING SYSTEM</b>						
Condensate Drain Trap	PVC	<b>22H54</b>	OX	OX	OX	OX
	Copper	<b>76W27</b>	X	X	X	X
Corrosion Protection	Factory		O	O	O	O
Drain Pan Overflow Switch		<b>21Z07</b>	OX	OX	OX	OX
Refrigerant Type		R-410A	O	O	O	O
<b>BLOWER - SUPPLY AIR</b>						
Blower	DirectPlus™ Direct Drive ECM Blower System with SZVAV	Factory	O	O	O	O
	DirectPlus™ Direct Drive ECM Blower System with VAV	Factory	O	O	O	O
<b>CABINET</b>						
Combination Coil/Hail Guards		<b>13T05</b>	X	X	X	X
Horizontal Discharge Kit		<b>51W25</b>	X	X	X	X
Return Air Adaptor Plate (for LC/LG and TC/TG/TH unit replacement)		<b>54W96</b>	OX	OX	OX	OX
<b>CONTROLS</b>						
Blower Proving Switch		<b>21Z10</b>	OX	OX	OX	OX
Commercial Controls	LonTalk® Module - For Lennox® CORE Control System	<b>54W27</b>	OX	OX	OX	OX
	Novar® LSM	Factory	O	O	O	O
	L Connection® Building Automation System	Factory	X	X	X	X
Dirty Filter Switch		<b>53W67</b>	OX	OX	OX	OX
Fresh Air Tempering		<b>21Z08</b>	OX	OX	OX	OX
Smoke Detector - Supply or Return (Power board and one sensor)		<b>11K76</b>	OX	OX	OX	OX
Smoke Detector - Supply and Return (Power board and two sensors)		<b>11K80</b>	OX	OX	OX	OX
<b>INDOOR AIR QUALITY</b>						
<b>Air Filters</b>						
Healthy Climate® High Efficiency Air Filters 20 x 25 x 2 in.	MERV 8 (Order 4)	<b>50W61</b>	OX	OX	OX	OX
	MERV 13 (Order 4)	<b>52W41</b>	OX	OX	OX	OX
	MERV 16 (Order 4)	<b>21U41</b>	OX	OX	OX	OX
Replacement Media Filter With Metal Mesh Frame 20 x 25 x 2 in. (includes non-pleated filter media)	(Order 4)	<b>Y3063</b>	X	X	X	X
<b>Indoor Air Quality (CO<sub>2</sub>) Sensors</b>						
Sensor - Wall-mount, off-white plastic cover with LCD display		<b>77N39</b>	X	X	X	X
Sensor - Wall-mount, off-white plastic cover, no display		<b>87N53</b>	X	X	X	X
Sensor - Black plastic case with LCD display, rated for plenum mounting		<b>87N52</b>	X	X	X	X
Sensor - Wall-mount, black plastic case, no display, rated for plenum mounting		<b>87N54</b>	X	X	X	X
CO <sub>2</sub> Sensor Duct Mounting Kit - for downflow applications		<b>85L43</b>	X	X	X	X
Aspiration Box - for duct mounting non-plenum rated CO <sub>2</sub> sensors ( <b>87N53</b> or <b>77N39</b> )		<b>90N43</b>	X	X	X	X
<b>Needlepoint Bipolar Ionization (NPBI)</b>						
Needlepoint Bipolar Ionization (NPBI) Kit		<b>21U36</b>	OX	OX	OX	OX
<b>UVC Germicidal Lamps</b>						
<sup>1</sup> Healthy Climate® UVC Light Kit (110/230V-1ph)		<b>21A93</b>	OX	OX	OX	OX

<sup>1</sup> For 460V units, field installed lamps utilize jumpers to the outdoor fan transformer for voltage needed. See the installation Instructions.

NOTE - Catalog numbers shown are for ordering optional accessories if a field installed option is available.

OX = Configure To Order (Factory Installed) or Field Installed

O = Configure To Order (Factory Installed)

X = Field Installed

## OPTIONS / ACCESSORIES

Item Description	Catalog Number	Unit Model No				
		092	102	120	150	
<b>ELECTRICAL</b>						
Voltage 60 Hz	208/230V-3ph	Factory	O	O	O	O
	460V-3ph	Factory	O	O	O	O
HACR Circuit Breakers		Factory	O	O	O	O
Disconnect Switch - See Electrical/Electric Heat tables for selection	80 amp	<b>54W56</b>	OX	OX	OX	OX
	150 amp	<b>54W57</b>	OX	OX	OX	OX
<sup>1</sup> Short-Circuit Current Rating (SCCR) of 100kA (includes Phase/Voltage Detection)		Factory	O	O	O	O
GFI Service Outlets	15 amp non-powered, field-wired (208/230V, 460V only)	<b>74M70</b>	OX	OX	OX	OX
Weatherproof Cover for GFI		<b>10C89</b>	X	X	X	X
<b>ELECTRIC HEAT</b>						
7.5 kW	208/230V-3ph	<b>10U96</b>	OX	OX		
	460V-3ph	<b>10U97</b>	OX	OX		
15 kW	208/230V-3ph	<b>10U99</b>	OX	OX	OX	OX
	460V-3ph	<b>10X01</b>	OX	OX	OX	OX
22.5 kW	208/230V-3ph	<b>10X03</b>	OX	OX	OX	OX
	460V-3ph	<b>10X04</b>	OX	OX	OX	OX
30 kW	208/230V-3ph	<b>10X06</b>	OX	OX	OX	OX
	460V-3ph	<b>10X07</b>	OX	OX	OX	OX
45 kW	208/230V-3ph	<b>10X09</b>	OX	OX	OX	OX
	460V-3ph	<b>10X11</b>	OX	OX	OX	OX
60 kW	208/230V-3ph	<b>10X13</b>			OX	OX
	460V-3ph	<b>10X14</b>			OX	OX

<sup>1</sup> Disconnect Switch not available with higher SCCR option. Short-Circuit Current Rating option not available on field installed electric heat.

NOTE - Catalog numbers shown are for ordering optional accessories if a field installed option is available.

OX = Configure To Order (Factory Installed) or Field Installed

O = Configure To Order (Factory Installed)

X = Field Installed

## OPTIONS / ACCESSORIES

Item Description	Catalog Number	Unit Model No			
		092	102	120	150
<b>ECONOMIZER</b>					
<b>High Performance Economizer (Approved for California Title 24 Building Standards / AMCA Class 1A Certified)</b>					
High Performance Economizer Downflow or Horizontal - Includes Outdoor Air Hood and Downflow Barometric Relief Dampers with Exhaust Hood NOTE - For horizontal economizer applications order optional Horizontal Low Profile Barometric Relief Dampers and Horizontal Discharge Kit separately.	20U80	OX	OX	OX	OX
<b>Economizer Controls</b>					
Differential Enthalpy (Not for Title 24)	Order 2 21Z09	OX	OX	OX	OX
Sensible Control	Sensor is Furnished Factory	O	O	O	O
Single Enthalpy (Not for Title 24)	21Z09	OX	OX	OX	OX
Global Control	Sensor Field Provided Factory	O	O	O	O
Building Pressure Control	13J77	X	X	X	X
Outdoor Air CFM Control	13J76	X	X	X	X
<b>Horizontal Barometric Relief Dampers (for horizontal economizer applications)</b>					
Horizontal Low Profile Barometric Relief Dampers With Exhaust Hood	53K04	X	X	X	X
<b>OUTDOOR AIR</b>					
<b>Outdoor Air Dampers</b>					
Motorized Dampers (Hood furnished)	14G28	OX	OX	OX	OX
Manual Dampers (Hood furnished)	14G29	OX	OX	OX	OX
<b>POWER EXHAUST</b>					
Standard Static	208/230V-3ph 53W44	OX	OX	OX	OX
	460V-3ph 53W45	OX	OX	OX	OX
<b>HUMIDITROL™+ HOT GAS REHEAT OPTION</b>					
Humiditrol+ Dehumidification Option		O	O	O	O
<b>ROOF CURBS</b>					
<b>Hybrid Roof Curbs, Downflow</b>					
8 in. height	11F54	X	X	X	X
14 in. height	11F55	X	X	X	X
18 in. height	11F56	X	X	X	X
24 in. height	11F57	X	X	X	X
<b>Adjustable Pitch Curb</b>					
14 in. height	54W50	X	X	X	X
<b>CEILING DIFFUSERS</b>					
Step-Down - Order one	RTD11-95S 13K61	X	X		
	RTD11-135S 13K62			X	
	RTD11-185S 13K63				X
Flush - Order one	FD11-95S 13K56	X	X		
	FD11-135S 13K57			X	
	FD11-185S 13K58				X
Transitions (Supply and Return) - Order one	C1DIFF30B-1 12X65	X	X		
	C1DIFF31B-1 12X66			X	
	C1DIFF32B-1 12X67				X

NOTE - Catalog numbers shown are for ordering optional accessories if a field installed option is available.

OX = Configure To Order (Factory Installed) or Field Installed

O = Configure To Order (Factory Installed)

X = Field Installed

SPECIFICATIONS			UNIT				
<b>General Data</b>	<b>Nominal Tonnage</b>		<b>7.5 Ton</b>	<b>8.5 Ton</b>	<b>10 Ton</b>	<b>12.5 Ton</b>	
	<b>Efficiency Type</b>		<b>Ultra-High</b>	<b>Ultra-High</b>	<b>Ultra-High</b>	<b>Ultra-High</b>	
	<b>Model Number</b>		<b>LCM092U4E</b>	<b>LCM102U4E</b>	<b>LCM120U4E</b>	<b>LCM150U4E</b>	
	<b>Blower Type</b>		DirectPlus™ ECM Direct Drive with SZVAV	DirectPlus™ ECM Direct Drive with SZVAV	DirectPlus™ ECM Direct Drive with SZVAV	DirectPlus™ ECM Direct Drive with SZVAV	
	<b>Model Number</b>		<b>LCM092U4P</b>	<b>LCM102U4P</b>	<b>LCM120U4P</b>	<b>LCM150U4P</b>	
	<b>Blower Type</b>		DirectPlus™ ECM Direct Drive with VAV	DirectPlus™ ECM Direct Drive with VAV	DirectPlus™ ECM Direct Drive with VAV	DirectPlus™ ECM Direct Drive with VAV	
	<b>Cooling Performance</b>	Gross Cooling Capacity - Btuh		90,500	101,600	121,800	144,000
		<sup>1</sup> Net Cooling Capacity - Btuh		86,000	97,000	114,000	138,000
<sup>1</sup> AHRI Rated Air Flow - cfm		2800	3400	3600	4400		
Total Unit Power - kW		7.2	8.1	9.5	12.5		
<sup>1</sup> IEER (Btuh/Watt)		22.0	21.0	21.0	20.0		
<sup>1</sup> EER (Btuh/Watt)		12.6	12.6	12.2	11.0		
<b>Refrigerant Charge</b>		Refrigerant Type		R-410A	R-410A	R-410A	R-410A
	Without Reheat Option	Circuit 1	13 lbs. 11 oz.	13 lbs. 15 oz.	15 lbs. 8 oz.	15 lb. 12 oz.	
		Circuit 2	9 lbs. 13 oz.	9 lbs. 10 oz.	11 lbs. 2 oz.	10 lb. 8 oz.	
	With Reheat Option	Circuit 1	15 lbs. 0 oz.	15 lbs. 0 oz.	18 lbs. 12 oz.	19 lb. 12 oz.	
		Circuit 2	9 lbs. 13 oz.	9 lbs. 10 oz.	11 lbs. 2 oz.	10 lb. 8 oz.	
	<b>Electric Heat Available - See page 18</b>			7.5, 15, 22.5, 30 & 45 kW		15, 22.5, 30, 45 & 60 kW	
<b>Compressor Type (number)</b>			Variable Capacity Scroll (1) Fixed Capacity Scroll (1)				
<b>Outdoor Coil</b>	Net face area (total) - sq. ft.		20.5	20.5	28	28	
	Tube diameter - in.		3/8	3/8	3/8	3/8	
	Number of rows		3	3	3	3	
	Fins per inch		20	20	20	20	
<b>Outdoor Coil Fans</b>	Motor - (No.) hp		(2) 1/3 ECM	(2) 1/3 ECM	(2) 1/3 ECM	(2) 1/3 ECM	
	Motor rpm		400-850	400-1020	500-1020	500-1020	
	Total Motor watts		65-450	65-750	65-750	65-750	
	Diameter - (No.) in.		(2) 24	(2) 24	(2) 24	(2) 24	
	Number of blades		3	3	3	3	
	Total Air volume - cfm		7300	8800	8800	8800	
	<b>Indoor Coil</b>	Net face area (total) - sq. ft.		13.54	13.54	13.54	13.54
Tube diameter - in.		3/8	3/8	3/8	3/8		
Number of rows		4	4	4	4		
Fins per inch		14	14	14	14		
Drain connection - Number and size		(1) 1 in. NPT coupling					
Expansion device type		Balance port TXV, removable head					
<b>Indoor Blower</b>	Nominal motor output		3.75 HP (ECM)	3.75 HP (ECM)	3.75 HP (ECM)	3.75 HP (ECM)	
	Blower wheel nominal diameter x width - in.		(1) 22 x 9	(1) 22 x 9	(1) 22 x 9	(1) 22 x 9	
<b>Filters</b>	Type of filter		Disposable				
	Number and size - in.		(4) 20 x 25 x 2				
<b>Electrical characteristics</b>			208/230V or 460V - 60 Hz - 3ph				

NOTE - Net capacity includes evaporator blower motor heat deduction. Gross capacity does not include evaporator blower motor heat deduction.

<sup>1</sup> AHRI Certified to AHRI Standard 340/360; 95°F outdoor air temperature and 80°F db/67°F wb entering evaporator air; minimum external duct static pressure.





# HUMIDITROL™ + DEHUMIDIFICATION SYSTEM RATINGS

## 7.5 | 8.5 TON - LCM092U4E/P / LCM102U4E/P WITH HUMIDITROL™+ OPERATING

Entering Wet Bulb Temperature	Outdoor Air Temperature Entering Outdoor Coil																							
	65°F						75°F						85°F						95°F					
	Total Air Vol.	Total Cool Cap.	Comp. Motor Input	Sensible To Total Ratio (S/T)			Total Air Vol.	Total Cool Cap.	Comp. Motor Input	Sensible To Total Ratio (S/T)			Total Air Vol.	Total Cool Cap.	Comp. Motor Input	Sensible To Total Ratio (S/T)			Total Air Vol.	Total Cool Cap.	Comp. Motor Input	Sensible To Total Ratio (S/T)		
				Dry Bulb						Dry Bulb						Dry Bulb						Dry Bulb		
cfm	kBtuh	kW	75°F	80°F	85°F	cfm	kBtuh	kW	75°F	80°F	85°F	cfm	kBtuh	kW	75°F	80°F	85°F	cfm	kBtuh	kW	75°F	80°F	85°F	
63°F	1201	23.6	2.2	0.5	0.7	1.0	1152	23.0	2.2	0.5	0.7	0.9	1059	17.8	2.4	0.4	0.6	0.9	879	10.5	2.7	0.1	0.4	0.8
67°F	895	28.2	2.2	0.3	0.4	0.6	866	27.1	2.2	0.3	0.4	0.6	814	20.9	2.4	0.2	0.4	0.5	759	14.4	2.8	N/A	0.2	0.4
71°F	684	31.5	2.1	0.2	0.3	0.4	686	29.8	2.1	0.2	0.3	0.4	642	23.8	2.5	0.1	0.2	0.3	576	17.7	2.8	N/A	0.1	0.2

NOTE - Both compressors operating at maximum capacity, indoor blower operating at optimal CFM and outdoor fan operating to maintain a discharge air temperature target equal to indoor dry bulb temperature.

## 10 TON - LCM120U4E/P WITH HUMIDITROL™+ OPERATING

Entering Wet Bulb Temperature	Outdoor Air Temperature Entering Outdoor Coil																							
	65°F						75°F						85°F						95°F					
	Total Air Vol.	Total Cool Cap.	Comp. Motor Input	Sensible To Total Ratio (S/T)			Total Air Vol.	Total Cool Cap.	Comp. Motor Input	Sensible To Total Ratio (S/T)			Total Air Vol.	Total Cool Cap.	Comp. Motor Input	Sensible To Total Ratio (S/T)			Total Air Vol.	Total Cool Cap.	Comp. Motor Input	Sensible To Total Ratio (S/T)		
				Dry Bulb						Dry Bulb						Dry Bulb						Dry Bulb		
cfm	kBtuh	kW	75°F	80°F	85°F	cfm	kBtuh	kW	75°F	80°F	85°F	cfm	kBtuh	kW	75°F	80°F	85°F	cfm	kBtuh	kW	75°F	80°F	85°F	
63°F	1382	30.7	3.1	0.4	0.6	0.8	1267	26.5	3.2	0.4	0.6	0.8	1170	24.1	3.2	0.3	0.6	0.8	1042	16.0	3.5	0.1	0.4	0.7
67°F	1067	34.6	3.1	0.2	0.4	0.5	1021	33.0	3.0	0.2	0.4	0.5	900	27.1	3.2	0.2	0.3	0.5	802	20.4	3.6	N/A	0.2	0.4
71°F	864	40.0	2.9	0.2	0.3	0.4	808	37.1	2.9	0.2	0.3	0.4	739	30.5	3.2	0.1	0.2	0.3	728	24.6	3.6	N/A	0.1	0.2

NOTE - Both compressors operating at maximum capacity, indoor blower operating at optimal CFM and outdoor fan operating to maintain a discharge air temperature target equal to indoor dry bulb temperature.

## 12.5 TON - LCM150U4E/P WITH HUMIDITROL™+ OPERATING

Entering Wet Bulb Temperature	Outdoor Air Temperature Entering Outdoor Coil																							
	65°F						75°F						85°F						95°F					
	Total Air Vol.	Total Cool Cap.	Comp. Motor Input	Sensible To Total Ratio (S/T)			Total Air Vol.	Total Cool Cap.	Comp. Motor Input	Sensible To Total Ratio (S/T)			Total Air Vol.	Total Cool Cap.	Comp. Motor Input	Sensible To Total Ratio (S/T)			Total Air Vol.	Total Cool Cap.	Comp. Motor Input	Sensible To Total Ratio (S/T)		
				Dry Bulb						Dry Bulb						Dry Bulb						Dry Bulb		
cfm	kBtuh	kW	75°F	80°F	85°F	cfm	kBtuh	kW	75°F	80°F	85°F	cfm	kBtuh	kW	75°F	80°F	85°F	cfm	kBtuh	kW	75°F	80°F	85°F	
63°F	1675	24.0	4.2	0.4	0.6	0.8	1556	31.7	4.1	0.4	0.6	0.8	1406	28.8	4.1	0.3	0.6	0.8	1309	19.9	4.5	0.2	0.5	0.8
67°F	1248	40.5	4.1	0.2	0.4	0.5	1215	38.9	4.0	0.2	0.4	0.5	1119	32.9	4.1	0.2	0.3	0.5	1020	24.7	4.6	N/A	0.2	0.4
71°F	1015	47.2	3.8	0.2	0.3	0.4	1009	43.8	3.8	0.2	0.3	0.4	932	36.2	4.2	0.0	0.2	0.3	927	29.7	4.6	N/A	0.1	0.2

NOTE - Both compressors operating at maximum capacity, indoor blower operating at optimal CFM and outdoor fan operating to maintain a discharge air temperature target equal to indoor dry bulb temperature.

## BLOWER DATA

**BLOWER TABLE INCLUDES RESISTANCE FOR BASE UNIT ONLY (NO HEAT SECTION) WITH DRY INDOOR COIL AND AIR FILTERS IN PLACE.**

FOR ALL UNITS ADD:

- 1 – Wet indoor coil air resistance of selected unit.
  - 2 – Any factory installed options air resistance (heat section, Economizer, etc.)
  - 3 – Any field installed accessories air resistance (duct resistance, diffuser, etc.)
- See page 25 for wet coil and option/accessory air resistance data.

**MINIMUM AIR VOLUME REQUIRED FOR USE WITH OPTIONAL ELECTRIC HEAT (Maximum Static Pressure - 2.0 in. w.g.)**

092 and 102 Models - 7.5 kW - 1750 cfm

All Models - 15 kW, 22.5 kW, 30 kW, 45 kW - 2750 cfm

120 and 150 Models - 60 kW - 3500 cfm

Total Air Volume cfm	Total Static Pressure - in. w.g.													
	0.2		0.4		0.6		0.8		1.0		1.2		1.4	
	RPM	Watts	RPM	Watts	RPM	Watts	RPM	Watts	RPM	Watts	RPM	Watts	RPM	Watts
1750	711	188	771	279	836	366	905	453	975	544	1044	640	1109	737
2000	752	242	812	332	876	420	944	510	1011	606	1075	709	1138	812
2250	799	300	860	389	923	479	988	575	1052	678	1113	787	1171	896
2500	853	362	914	453	976	548	1038	650	1097	761	1154	877	1209	990
2750	914	434	974	529	1033	629	1091	739	1146	858	1199	979	1250	1098
3000	980	513	1037	614	1092	720	1146	837	1198	961	1247	1088	1295	1215
3250	1048	598	1101	705	1153	819	1203	941	1251	1071	1298	1206	1343	1343
3500	1116	693	1166	809	1214	931	1261	1060	1307	1198	1351	1341	1395	1489
3750	1185	806	1232	931	1277	1063	1322	1201	1365	1348	1407	1499	1448	1657
4000	1254	937	1299	1072	1341	1214	1383	1363	1424	1518	1464	1679	1503	1844
4250	1324	1089	1366	1234	1406	1386	1445	1545	1484	1708	1522	1876	1559	2046
4500	1395	1262	1433	1417	1471	1579	1508	1745	1544	1913	1581	2084	1616	2256
4750	1465	1455	1501	1619	1536	1787	1571	1957	1606	2128	1641	2299	1675	2470
5000	1534	1666	1568	1834	1602	2004	1635	2174	1668	2345	1701	2514	1735	2682
5250	1603	1887	1635	2055	1667	2224	1699	2392	1731	2559	1763	2724	---	---
5500	1671	2110	1702	2275	1733	2441	1764	2605	---	---	---	---	---	---
5750	1738	2325	1768	2488	---	---	---	---	---	---	---	---	---	---

Total Air Volume cfm	Total Static Pressure - in. w.g.											
	1.6		1.8		2.0		2.2		2.4		2.6	
	RPM	Watts	RPM	Watts	RPM	Watts	RPM	Watts	RPM	Watts	RPM	Watts
1750	1172	833	1231	932	1287	1039	1340	1156	1391	1283	1442	1426
2000	1197	913	1253	1019	1306	1135	1357	1261	1407	1398	1457	1547
2250	1227	1003	1280	1117	1330	1242	1379	1378	1428	1525	1477	1680
2500	1261	1103	1311	1226	1360	1361	1407	1507	1454	1663	1501	1826
2750	1299	1219	1347	1350	1394	1494	1440	1649	1485	1813	1530	1982
3000	1342	1346	1388	1487	1432	1640	1476	1803	1520	1973	1563	2146
3250	1388	1485	1432	1638	1475	1800	1517	1969	1558	2143	1600	2319
3500	1437	1643	1479	1805	1519	1975	1560	2148	1600	2325	1640	2502
3750	1489	1821	1528	1990	1567	2164	1605	2340	1645	2517	1685	2693
4000	1541	2014	1579	2187	1616	2364	1654	2540	1693	2715	1732	2887
4250	1596	2218	1632	2393	1668	2569	1705	2742	1743	2913	---	---
4500	1652	2429	1687	2603	1722	2775	1759	2944	---	---	---	---
4750	1709	2641	1743	2811	1778	2979	---	---	---	---	---	---
5000	1768	2850	---	---	---	---	---	---	---	---	---	---
5250	---	---	---	---	---	---	---	---	---	---	---	---
5500	---	---	---	---	---	---	---	---	---	---	---	---
5750	---	---	---	---	---	---	---	---	---	---	---	---



## BLOWER DATA

### POWER EXHAUST FAN PERFORMANCE

Return Air System Static Pressure	Air Volume Exhausted
in. w.g.	cfm
0	3175
0.05	2955
0.10	2685
0.15	2410
0.20	2165
0.25	1920
0.30	1420
0.35	1200

### FACTORY INSTALLED OPTIONS/FIELD INSTALLED ACCESSORY AIR RESISTANCE - in. w.g.

Air Volume cfm	Wet Indoor Coil		Electric Heat	Economizer	Humiditrol + Condenser Reheat Coil	Filters			Return Air Adaptor Plate
	092, 102	120, 150				MERV 8	MERV 13	MERV 16	
1750	0.04	0.04	0.03	0.05	0.02	0.01	0.03	0.06	0.00
2000	0.05	0.05	0.03	0.06	0.02	0.01	0.03	0.08	0.00
2250	0.06	0.06	0.04	0.08	0.02	0.01	0.04	0.09	0.00
2500	0.07	0.07	0.04	0.11	0.03	0.01	0.05	0.10	0.00
2750	0.08	0.08	0.05	0.12	0.03	0.02	0.05	0.11	0.00
3000	0.10	0.09	0.06	0.13	0.03	0.02	0.06	0.12	0.02
3250	0.11	0.10	0.06	0.15	0.04	0.02	0.06	0.13	0.02
3500	0.12	0.11	0.09	0.15	0.04	0.03	0.07	0.15	0.04
3750	0.14	0.13	0.09	0.15	0.05	0.03	0.08	0.16	0.07
4000	0.15	0.14	0.09	0.19	0.05	0.04	0.08	0.17	0.09
4250	0.17	0.15	0.13	0.19	0.06	0.04	0.09	0.19	0.11
4500	0.19	0.17	0.14	0.22	0.07	0.04	0.09	0.20	0.12
4750	0.20	0.18	0.17	0.25	0.07	0.05	0.10	0.21	0.16
5000	0.22	0.20	0.20	0.29	0.08	0.06	0.10	0.23	0.18
5250	0.24	0.22	0.22	0.32	0.08	0.06	0.11	0.24	0.19
5500	0.25	0.23	0.25	0.34	0.09	0.07	0.12	0.25	0.22
5750	0.27	0.25	0.31	0.45	0.10	0.07	0.12	0.27	0.25
6000	0.29	0.27	0.33	0.52	0.10	0.08	0.13	0.28	0.27

## BLOWER DATA

### CEILING DIFFUSERS AIR RESISTANCE - in. w.g.

Unit Size	RTD11 Step-Down Diffuser			FD11 Flush Diffuser	
	Air Volume cfm	2 Ends Open	1 Side, 2 Ends Open		All Ends & Sides Open
092 Models	2400	0.21	0.18	0.15	0.14
	2600	0.24	0.21	0.18	0.17
	2800	0.27	0.24	0.21	0.20
	3000	0.32	0.29	0.25	0.25
	3200	0.41	0.37	0.32	0.31
	3400	0.50	0.45	0.39	0.37
	3600	0.61	0.54	0.48	0.44
	3800	0.73	0.63	0.57	0.51
102 & 120 Models	3600	0.36	0.28	0.23	0.15
	3800	0.40	0.32	0.26	0.18
	4000	0.44	0.36	0.29	0.21
	4200	0.49	0.40	0.33	0.24
	4400	0.54	0.44	0.37	0.27
	4600	0.60	0.49	0.42	0.31
	4800	0.65	0.53	0.46	0.35
	5000	0.69	0.58	0.50	0.39
150 Models	5200	0.75	0.62	0.54	0.43
	4200	0.22	0.19	0.16	0.10
	4400	0.28	0.24	0.20	0.12
	4600	0.34	0.29	0.24	0.15
	4800	0.40	0.34	0.29	0.19
	5000	0.46	0.39	0.34	0.23
	5200	0.52	0.44	0.39	0.27
	5400	0.58	0.49	0.43	0.31
5600	0.64	0.54	0.47	0.35	
5800	0.70	0.59	0.51	0.39	

### CEILING DIFFUSER AIR THROW DATA

Model No.	Air Volume cfm	<sup>1</sup> Effective Throw Range	
		RTD11 Step-Down ft.	FD11 Flush ft.
	092 Models	2600	24 - 29
2800		25 - 30	20 - 28
3000		27 - 33	21 - 29
3200		28 - 35	22 - 29
3400		30 - 37	22 - 30
102, 120 Models	3600	25 - 33	22 - 29
	3800	27 - 35	22 - 30
	4000	29 - 37	24 - 33
	4200	32 - 40	26 - 35
	4400	34 - 42	28 - 37
150 Models	5600	39 - 49	28 - 37
	5800	42 - 51	29 - 38
	6000	44 - 54	40 - 50
	6200	45 - 55	42 - 51
	6400	46 - 55	43 - 52
6600	47 - 56	45 - 56	

<sup>1</sup> Throw is the horizontal or vertical distance an air stream travels on leaving the outlet or diffuser before the maximum velocity is reduced to 50 ft. per minute. Four sides open.

**ELECTRICAL/ELECTRIC HEAT DATA**

**7.5 TON**

Model No.		LCH092U4E/ LCH092U4P	
<sup>1</sup> Voltage - 60Hz		208/230V-3ph	460V-3ph
Compressor 1	Rated Load Amps	8.5	4
	Locked Rotor Amps	17	10
Compressor 2	Rated Load Amps	13.7	6.1
	Locked Rotor Amps	83.1	43
Outdoor Fan Motors (2)	Full Load Amps (total)	2.8 (5.6)	1.4 (2.8)
Power Exhaust (1) 0.33 HP	Full Load Amps	2.4	1.3
Service Outlet 115V GFI (amps)		15	15
Indoor Blower Motor	Horsepower	3.75	3.75
	Full Load Amps	8.8	4.3
<sup>2</sup> Maximum Overcurrent Protection (MOCP)	Unit Only	50	20
	With (1) 0.33 HP Power Exhaust	50	25
<sup>3</sup> Minimum Circuit Ampacity (MCA)	Unit Only	41	19
	With (1) 0.33 HP Power Exhaust	43	21

**ELECTRIC HEAT DATA**

Electric Heat Voltage				208V	240V	480V
<sup>2</sup> Maximum Overcurrent Protection (MOCP)	Unit+ Electric Heat	7.5 kW		50	50	20
		15 kW		60	60	30
		22.5 kW		<sup>4</sup> 70	80	40
		30 kW		<sup>4</sup> 90	110	60
		45 kW		150	150	80
<sup>3</sup> Minimum Circuit Ampacity (MCA)	Unit+ Electric Heat	7.5 kW		41	41	19
		15 kW		51	57	28
		22.5 kW		70	79	40
		30 kW		90	102	51
		45 kW		129	147	74
<sup>2</sup> Maximum Overcurrent Protection (MOCP)	Unit+ Electric Heat and (1) 0.33 HP Power Exhaust	7.5 kW		50	50	25
		15 kW		60	60	30
		22.5 kW		<sup>4</sup> 80	90	45
		30 kW		<sup>4</sup> 100	110	60
		45 kW		150	150	80
<sup>3</sup> Minimum Circuit Ampacity (MCA)	Unit+ Electric Heat and (1) 0.33 HP Power Exhaust	7.5 kW		43	43	21
		15 kW		54	60	30
		22.5 kW		73	82	41
		30 kW		93	105	53
		45 kW		132	150	75

**ELECTRICAL ACCESSORIES**

Disconnect	7.5 kW	15 kW	22.5 kW	30 kW	45 kW
	54W56	54W56	54W56	54W56	54W56
	54W56	54W56	54W56	54W56	54W56
	54W56	54W56	54W56	54W56	54W56
	54W57	54W57	54W57	54W56	54W56
	54W57	54W57	54W57	54W56	54W56

NOTE - All units have a minimum Short Circuit Current Rating (SCCR) of 5000 amps.

<sup>1</sup> Extremes of operating range are plus and minus 10% of line voltage.

<sup>2</sup> HACR type breaker or fuse.

<sup>3</sup> Refer to National or Canadian Electrical Code manual to determine wire, fuse and disconnect size requirements.

<sup>4</sup> Factory installed circuit breaker not available.

**ELECTRICAL/ELECTRIC HEAT DATA**

**8.5 TON**

Model No.		LCH102U4E/ LCH102U4P	
<sup>1</sup> Voltage - 60Hz		208/230V-3ph	460V-3ph
Compressor 1	Rated Load Amps	11.8	5.5
	Locked Rotor Amps	17	10
Compressor 2	Rated Load Amps	13.7	6.1
	Locked Rotor Amps	83.1	43
Outdoor Fan Motors (2)	Full Load Amps (total)	2.8 (5.6)	1.4 (2.8)
Power Exhaust (1) 0.33 HP	Full Load Amps	2.4	1.3
Service Outlet 115V GFI (amps)		15	15
Indoor Blower Motor	Horsepower	3.75	3.75
	Full Load Amps	8.8	4.3
<sup>2</sup> Maximum Overcurrent Protection (MOCP)	Unit Only	50	25
	With (1) 0.33 HP Power Exhaust	50	25
<sup>3</sup> Minimum Circuit Ampacity (MCA)	Unit Only	44	21
	With (1) 0.33 HP Power Exhaust	46	22

**ELECTRIC HEAT DATA**

Electric Heat Voltage			208V	240V	480V
<sup>2</sup> Maximum Overcurrent Protection (MOCP)	Unit+ Electric Heat	15 kW	50	50	25
		22.5 kW	60	60	30
		30 kW	<sup>4</sup> 70	80	40
		45 kW	<sup>4</sup> 90	110	60
		60 kW	150	150	80
<sup>3</sup> Minimum Circuit Ampacity (MCA)	Unit+ Electric Heat	15 kW	44	44	21
		22.5 kW	51	57	28
		30 kW	70	79	40
		45 kW	90	102	51
		60 kW	129	147	74
<sup>2</sup> Maximum Overcurrent Protection (MOCP)	Unit+ Electric Heat and (1) 0.33 HP Power Exhaust	15 kW	50	50	25
		22.5 kW	60	60	30
		30 kW	<sup>4</sup> 80	90	45
		45 kW	<sup>4</sup> 100	110	60
		60 kW	150	150	80
<sup>3</sup> Minimum Circuit Ampacity (MCA)	Unit+ Electric Heat and (1) 0.33 HP Power Exhaust	15 kW	46	46	22
		22.5 kW	54	60	30
		30 kW	73	82	41
		45 kW	93	105	53
		60 kW	132	150	75

**ELECTRICAL ACCESSORIES**

Disconnect	15 kW	54W56	54W56	54W56
	22.5 kW	54W56	54W56	54W56
	30 kW	54W57	54W57	54W56
	45 kW	54W57	54W57	54W56
	60 kW	N/A	N/A	54W57

NOTE - All units have a minimum Short Circuit Current Rating (SCCR) of 5000 amps.

<sup>1</sup> Extremes of operating range are plus and minus 10% of line voltage.

<sup>2</sup> HACR type breaker or fuse.

<sup>3</sup> Refer to National or Canadian Electrical Code manual to determine wire, fuse and disconnect size requirements.

<sup>4</sup> Factory installed circuit breaker not available.

**ELECTRICAL/ELECTRIC HEAT DATA**

**10 TON**

Model No.		LCH120U4E/ LCH120U4P	
<sup>1</sup> Voltage - 60Hz		208/230V-3ph	460V-3ph
Compressor 1	Rated Load Amps	13.5	6.3
	Locked Rotor Amps	21	11
Compressor 2	Rated Load Amps	16	7.8
	Locked Rotor Amps	110	52
Outdoor Fan Motors (2)	Full Load Amps (total)	2.8 (5.6)	1.4 (2.8)
Power Exhaust (1) 0.33 HP	Full Load Amps	2.4	1.3
Service Outlet 115V GFI (amps)		15	15
Indoor Blower Motor	Horsepower	3.75	3.75
	Full Load Amps	8.8	4.3
<sup>2</sup> Maximum Overcurrent Protection (MOCP)	Unit Only	60	30
	With (1) 0.33 HP Power Exhaust	60	30
<sup>3</sup> Minimum Circuit Ampacity (MCA)	Unit Only	48	24
	With (1) 0.33 HP Power Exhaust	51	25

**ELECTRIC HEAT DATA**

Electric Heat Voltage			208V	240V	480V
<sup>2</sup> Maximum Overcurrent Protection (MOCP)	Unit+ Electric Heat	15 kW	60	60	30
		22.5 kW	<sup>4</sup> 70	80	40
		30 kW	<sup>4</sup> 90	110	60
		45 kW	150	150	80
		60 kW	<sup>4</sup> 150	175	80
<sup>3</sup> Minimum Circuit Ampacity (MCA)	Unit+ Electric Heat	15 kW	51	57	28
		22.5 kW	70	79	40
		30 kW	90	102	51
		45 kW	129	147	74
		60 kW	137	156	78
<sup>2</sup> Maximum Overcurrent Protection (MOCP)	Unit+ Electric Heat and (1) 0.33 HP Power Exhaust	15 kW	60	60	30
		22.5 kW	<sup>4</sup> 80	90	45
		30 kW	<sup>4</sup> 100	110	60
		45 kW	150	150	80
		60 kW	<sup>4</sup> 150	175	80
<sup>3</sup> Minimum Circuit Ampacity (MCA)	Unit+ Electric Heat and (1) 0.33 HP Power Exhaust	15 kW	54	60	30
		22.5 kW	73	82	41
		30 kW	93	105	53
		45 kW	132	150	75
		60 kW	140	159	80

**ELECTRICAL ACCESSORIES**

Disconnect	15 kW	54W56	54W56	54W56
	22.5 kW	54W56	54W56	54W56
	30 kW	54W57	54W57	54W56
	45 kW	54W57	54W57	54W56
	60 kW	N/A	N/A	54W57

NOTE - All units have a minimum Short Circuit Current Rating (SCCR) of 5000 amps.

<sup>1</sup> Extremes of operating range are plus and minus 10% of line voltage.

<sup>2</sup> HACR type breaker or fuse.

<sup>3</sup> Refer to National or Canadian Electrical Code manual to determine wire, fuse and disconnect size requirements.

<sup>4</sup> Factory installed circuit breaker not available.

**ELECTRICAL/ELECTRIC HEAT DATA**
**12.5 TON**

Model No.		LCH150U4E/ LCH150U4P	
<sup>1</sup> Voltage - 60Hz		<b>208/230V-3ph</b>	<b>460V-3ph</b>
Compressor 1	Rated Load Amps	16.4	7.7
	Locked Rotor Amps	21	11
Compressor 2	Rated Load Amps	19.6	8.2
	Locked Rotor Amps	136	66.1
Outdoor Fan Motors (2)	Full Load Amps	2.8	1.4
	(total)	(5.6)	(2.8)
Power Exhaust (1) 0.33 HP	Full Load Amps	2.4	1.3
Service Outlet 115V GFI (amps)		15	15
Indoor Blower Motor	Horsepower	3.75	3.75
	Full Load Amps	8.8	4.3
<sup>2</sup> Maximum Overcurrent Protection (MOCP)		70	30
Unit Only		70	30
With (1) 0.33 HP Power Exhaust		70	30
<sup>3</sup> Minimum Circuit Ampacity (MCA)		56	26
Unit Only		56	26
With (1) 0.33 HP Power Exhaust		58	27

**ELECTRIC HEAT DATA**

Electric Heat Voltage			<b>208V</b>	<b>240V</b>	<b>480V</b>
<sup>2</sup> Maximum Overcurrent Protection (MOCP)	Unit+ Electric Heat	<b>15 kW</b>	70	70	30
		<b>22.5 kW</b>	<sup>4</sup> 70	80	40
		<b>30 kW</b>	<sup>4</sup> 90	110	60
		<b>45 kW</b>	150	150	80
		<b>60 kW</b>	<sup>4</sup> 150	175	80
<sup>3</sup> Minimum Circuit Ampacity (MCA)	Unit+ Electric Heat	<b>15 kW</b>	56	57	28
		<b>22.5 kW</b>	70	79	40
		<b>30 kW</b>	90	102	51
		<b>45 kW</b>	129	147	74
		<b>60 kW</b>	137	156	78
<sup>2</sup> Maximum Overcurrent Protection (MOCP)	Unit+ Electric Heat and (1) 0.33 HP Power Exhaust	<b>15 kW</b>	70	70	30
		<b>22.5 kW</b>	<sup>4</sup> 80	90	45
		<b>30 kW</b>	<sup>4</sup> 100	110	60
		<b>45 kW</b>	150	150	80
		<b>60 kW</b>	<sup>4</sup> 150	175	80
<sup>3</sup> Minimum Circuit Ampacity (MCA)	Unit+ Electric Heat and (1) 0.33 HP Power Exhaust	<b>15 kW</b>	58	60	30
		<b>22.5 kW</b>	73	82	41
		<b>30 kW</b>	93	105	53
		<b>45 kW</b>	132	150	75
		<b>60 kW</b>	140	159	80

**ELECTRICAL ACCESSORIES**

Disconnect		<b>54W56</b>	<b>54W56</b>	<b>54W56</b>
	<b>15 kW</b>	<b>54W56</b>	<b>54W56</b>	<b>54W56</b>
	<b>22.5 kW</b>	<b>54W56</b>	<b>54W56</b>	<b>54W56</b>
	<b>30 kW</b>	<b>54W57</b>	<b>54W57</b>	<b>54W56</b>
	<b>45 kW</b>	<b>54W57</b>	<b>54W57</b>	<b>54W56</b>
	<b>60 kW</b>	<b>N/A</b>	<b>N/A</b>	<b>54W57</b>

NOTE - All units have a minimum Short Circuit Current Rating (SCCR) of 5000 amps.

<sup>1</sup> Extremes of operating range are plus and minus 10% of line voltage.

<sup>2</sup> HACR type breaker or fuse.

<sup>3</sup> Refer to National or Canadian Electrical Code manual to determine wire, fuse and disconnect size requirements.

<sup>4</sup> Factory installed circuit breaker not available.

## ELECTRIC HEAT CAPACITIES

Volts Input	7.5 kW			15 kW			22.5 kW			30 kW			45 kW			60 kW		
	kW Input	Btuh Output	No. of Stages	kW Input	Btuh Output	No. of Stages	kW Input	Btuh Output	No. of Stages	kW Input	Btuh Output	No. of Stages	kW Input	Btuh Output	No. of Stages	kW Input	Btuh Output	No. of Stages
208	5.6	19,100	1	11.3	38,600	1	16.9	57,700	2	22.5	76,800	2	33.8	115,300	2	45.0	153,600	2
220	6.3	21,500	1	12.6	43,000	1	18.9	64,500	2	25.2	86,000	2	37.8	129,000	2	50.4	172,000	2
230	6.9	23,600	1	13.8	47,100	1	20.7	70,700	2	27.5	93,900	2	41.3	141,000	2	55.1	188,000	2
240	7.5	25,600	1	15.0	51,200	1	22.5	76,800	2	30.0	102,400	2	45.0	153,600	2	60.0	204,800	2
440	6.9	21,500	1	12.6	43,000	1	18.9	64,500	2	25.2	86,000	2	37.8	129,000	2	50.4	172,000	2
460	6.9	23,600	1	13.8	47,100	1	20.7	70,700	2	27.5	93,900	2	41.3	141,000	2	55.1	188,000	2
480	7.5	25,600	1	15.0	51,200	1	22.5	76,800	2	30.0	102,400	2	45.0	153,600	2	60.0	204,800	2

## UNIT CLEARANCES

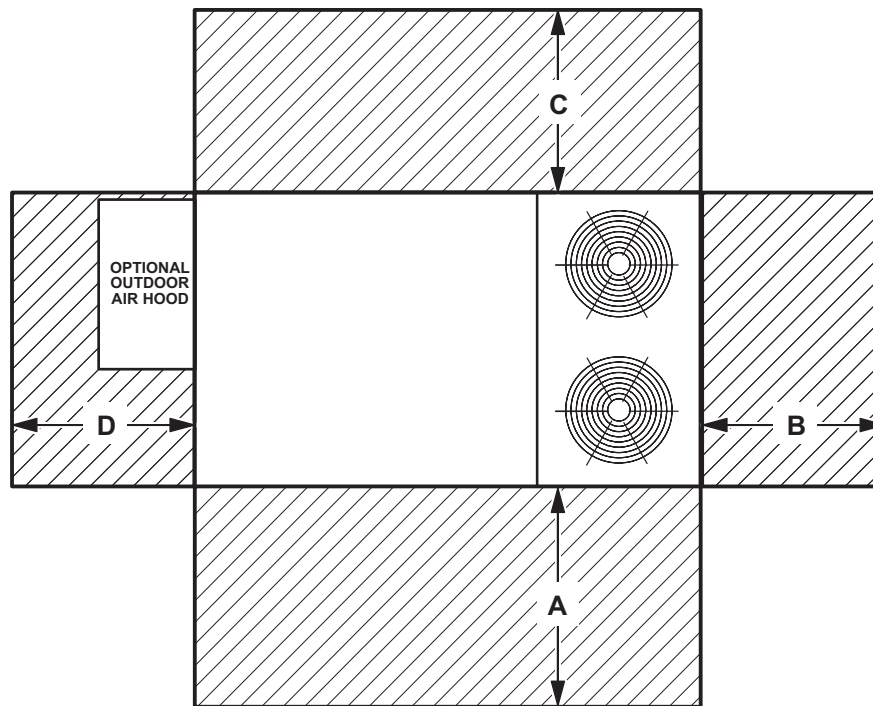

<sup>1</sup> Unit Clearance	A		B		C		D		Top Clearance
	in.	mm	in.	mm	in.	mm	in.	mm	
<b>Service Clearance</b>	60	1524	36	914	36	934	60	1524	Unobstructed
<b>Minimum Operation Clearance</b>	36	914	36	914	36	914	36	914	

NOTE - Entire perimeter of unit base requires support when elevated above the mounting surface.

<sup>1</sup> Service Clearance - Required for removal of serviceable parts.

Minimum Operation Clearance - Required clearance for proper unit operation.

## OUTDOOR SOUND DATA

Unit Model Number	Octave Band Sound Power Levels dBA, re 10 <sup>-12</sup> Watts - Center Frequency - Hz							<sup>1</sup> Sound Rating Number (dBA)
	125	250	500	1000	2000	4000	8000	
092-102 Min.	58	62	62	60	55	47	60	68
092-102 Max.	72	77	81	79	74	68	66	85
120-150 Min.	55	60	62	60	56	48	60	67
120-150 Max.	79	78	85	83	79	76	73	89

Note - The octave sound power data does not include tonal corrections.

<sup>1</sup> Sound Rating Number according to AHRI Standard 370-2001 (includes pure tone penalty).

Sound Rating Number is the overall A-Weighted Sound Power Level (L<sub>WA</sub>), dBA (100 Hz to 10,000 Hz).

WEIGHT DATA				UNIT
Model Number	Net		Shipping	
	lbs.	kg	lbs.	kg
092 Base Unit	1120	508	1205	547
092 Max. Unit	1277	579	1362	618
102 Base Unit	1127	511	1212	550
102 Max. Unit	1284	582	1369	621
120 Base Unit	1162	527	1247	566
120 Max. Unit	1326	601	1411	640
150 Base Unit	1178	534	1263	573
150 Max. Unit	1342	609	1427	647

WEIGHT DATA		OPTIONS / ACCESSORIES	
Description	Shipping Weight		kg
	lbs.		
<b>ECONOMIZER / OUTDOOR AIR / EXHAUST</b>			
<b>Economizer</b>			
Economizer Dampers	60		27
Outdoor Air Hood (downflow)	23		10
Barometric Relief Dampers (downflow)	8		4
Barometric Relief Dampers (low profile horizontal)	20		9
<b>Outdoor Air Dampers</b>			
Outdoor Air Damper Section - Automatic	51		23
Outdoor Air Damper Section - Manual	39		18
<b>Power Exhaust</b>	31		14
<b>ELECTRIC HEAT</b>			
7.5 kW	50		23
15 kW	50		23
22.5 kW	57		26
30 kW	57		26
45 kW	59		27
60 kW	68		31
<b>HUMIDITROL™+ HOT GAS REHEAT SYSTEM</b>			
Humiditrol+ Dehumidification Option	20		9
<b>ROOF CURBS</b>			
<b>Hybrid Roof Curbs, Downflow</b>			
8 in. height	60		27
14 in. height	85		39
18 in. height	100		45
24 in. height	125		57
<b>Adjustable Pitch Curb, Downflow</b>			
14 in. height	191		82
<b>CEILING DIFFUSERS</b>			
<b>Step-Down</b>			
	RTD11-95S	118	54
	RTD11-135S	135	61
	RTD11-185S	168	76
<b>Flush</b>			
	FD11-95S	118	54
	FD11-135S	135	61
	FD11-185S	168	76
<b>Transitions</b>			
	C1DIFF30B-1	30	14
	C1DIFF31B-1	32	15
	C1DIFF32B-1	36	16
<b>PACKAGING</b>			
LTL Packaging (less than truck load)		105	48



## WEIGHT DATA - OPTIONS / ACCESSORIES

Description	Shipping Weight	
	lbs.	kg
<b>ECONOMIZER / OUTDOOR AIR / EXHAUST</b>		
<b>Economizer</b>		
Economizer Dampers	60	27
Outdoor Air Hood (downflow)	23	10
Barometric Relief Dampers (downflow)	8	4
Barometric Relief Dampers (low profile horizontal)	20	9
<b>Outdoor Air Dampers</b>		
Outdoor Air Damper Section - Automatic	51	23
Outdoor Air Damper Section - Manual	39	18
<b>Power Exhaust</b>	31	14
<b>ELECTRIC HEAT</b>		
7.5 kW	50	23
15 kW	50	23
22.5 kW	57	26
30 kW	57	26
45 kW	59	27
60 kW	68	31
<b>ROOF CURBS</b>		
<b>Hybrid Roof Curbs, Downflow</b>		
8 in. height	60	27
14 in. height	85	39
18 in. height	100	45
24 in. height	125	57
<b>Adjustable Pitch Curb, Downflow</b>		
14 in. height	191	82
<b>CEILING DIFFUSERS</b>		
<b>Step-Down</b>		
RTD11-95S	118	54
RTD11-135S	135	61
RTD11-185S	168	76
<b>Flush</b>		
FD11-95S	118	54
FD11-135S	135	61
FD11-185S	168	76
<b>Transitions</b>		
C1DIFF30B-1	30	14
C1DIFF31B-1	32	15
C1DIFF32B-1	36	16
<b>PACKAGING</b>		
LTL Packaging (less than truck load)	105	48

# DIMENSIONS

# UNIT

Model No.	CORNER WEIGHTS																CENTER OF GRAVITY							
	AA				BB				CC				DD				EE				FF			
	Base		Max.		Base		Max.		Base		Max.		Base		Max.		Base		Max.		Base		Max.	
	lbs.	kg	lbs.	kg	lbs.	kg	lbs.	kg	lbs.	kg	lbs.	kg	lbs.	kg	lbs.	kg	in.	mm	in.	mm	in.	mm	in.	mm
092	281	127	327	148	252	114	286	130	275	125	306	139	312	142	358	162	46.5	1181	45.5	1156	24.5	622	25.5	648
102	282	128	329	149	254	115	287	130	276	125	308	139	314	143	360	163	46.5	1181	45.5	1156	24.5	622	25.5	648
120	294	133	340	154	264	120	297	135	283	128	318	144	321	146	372	169	46.5	1181	45.5	1156	24.5	622	25.5	648
150	304	138	350	159	273	124	306	139	293	133	327	148	332	151	383	174	46.5	1181	45.5	1156	24.5	622	25.5	648

Base Unit - The unit with NO INTERNAL OPTIONS.

Max. Unit - The unit with ALL INTERNAL OPTIONS Installed. (Economizer, Standard Static Power Exhaust Fans, Controls, etc.). Does not include accessories external to unit or high static power exhaust.

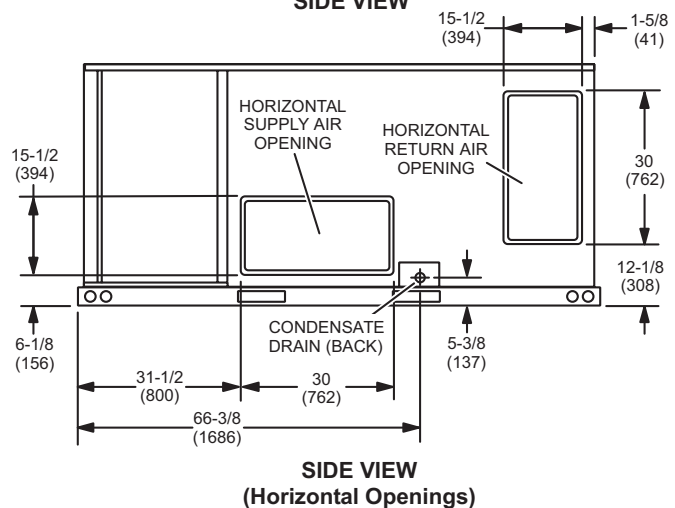
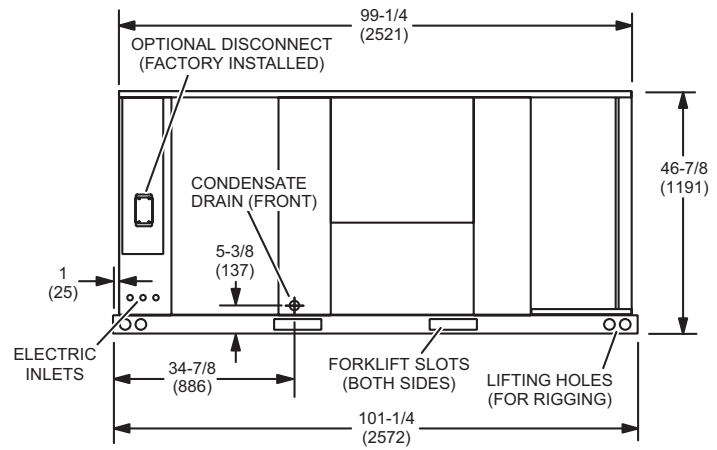
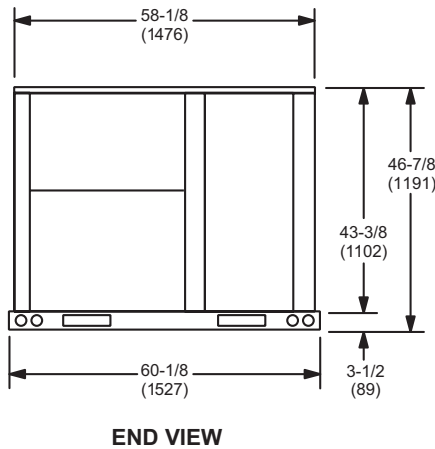
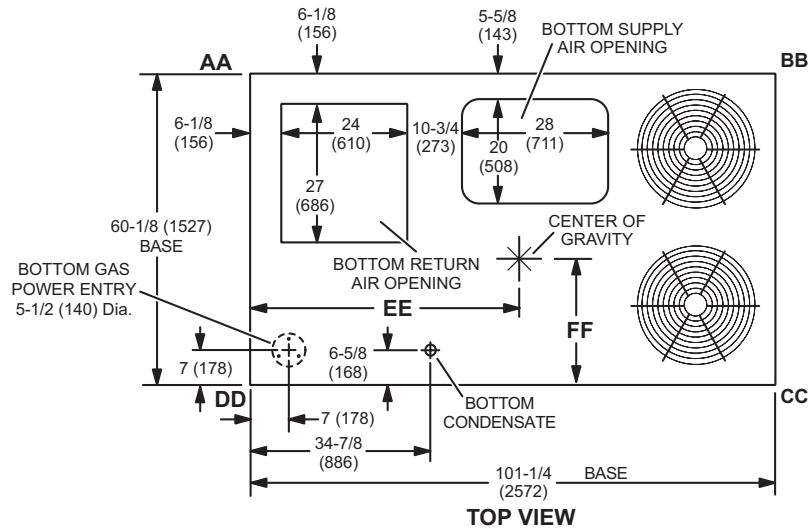

**OUTDOOR AIR HOOD DETAIL**

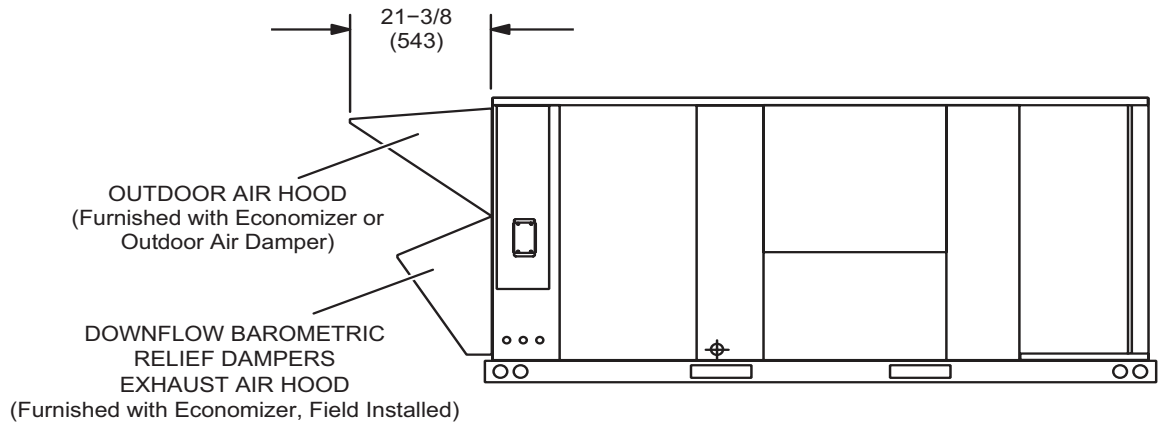

**HORIZONTAL ECONOMIZER APPLICATION**

**(With Furnished Barometric Relief Dampers and Optional Horizontal Discharge Kit - Required)**

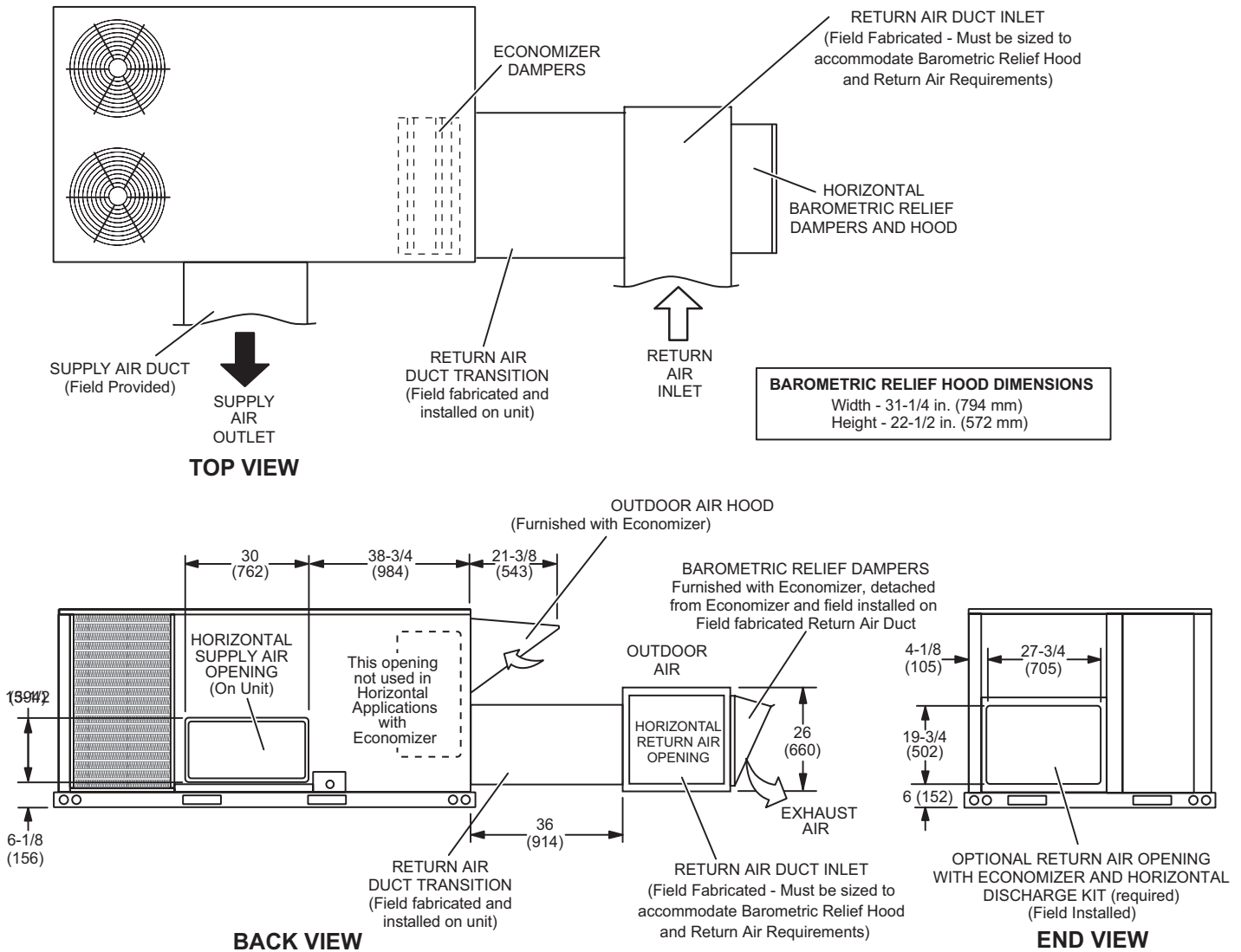

**NOTE** - Return Air Duct and Transition must be supported.

**BAROMETRIC RELIEF DAMPERS (Furnished with Economizer)**

(Field installed in horizontal return air duct adjacent to unit)

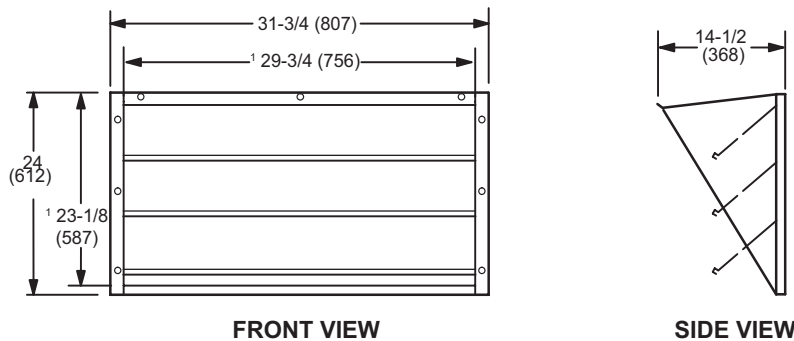

<sup>1</sup> NOTE - Opening size required in return air duct.

**HORIZONTAL ECONOMIZER APPLICATION**

(with Optional Low Profile Horizontal Barometric Relief Dampers and Horizontal Discharge Kit - Required)

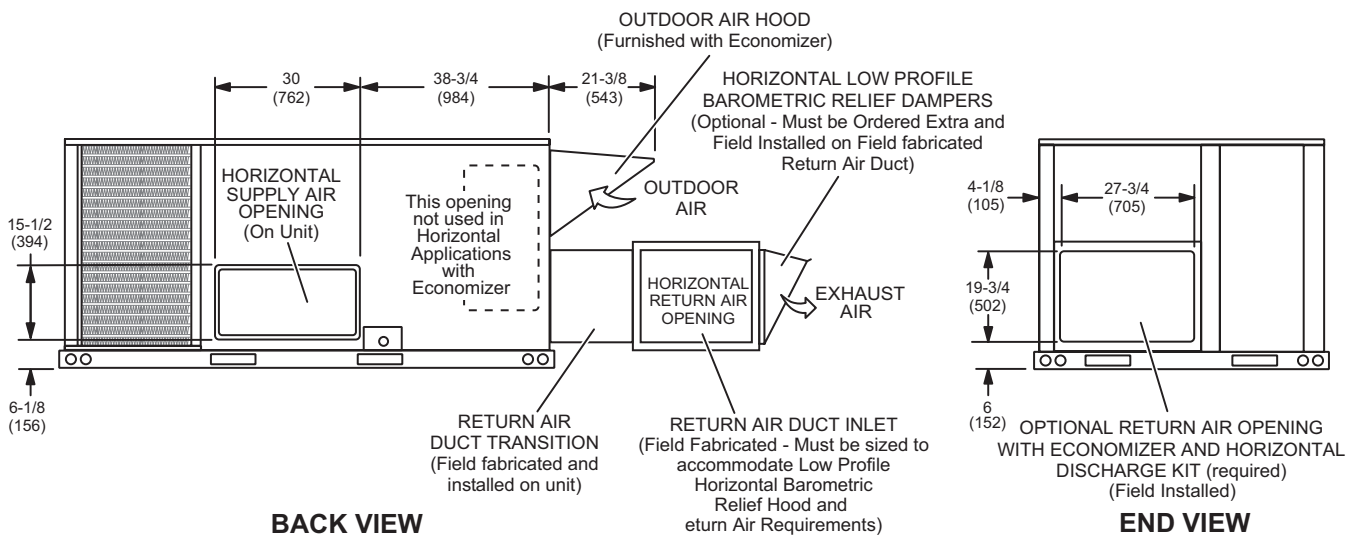
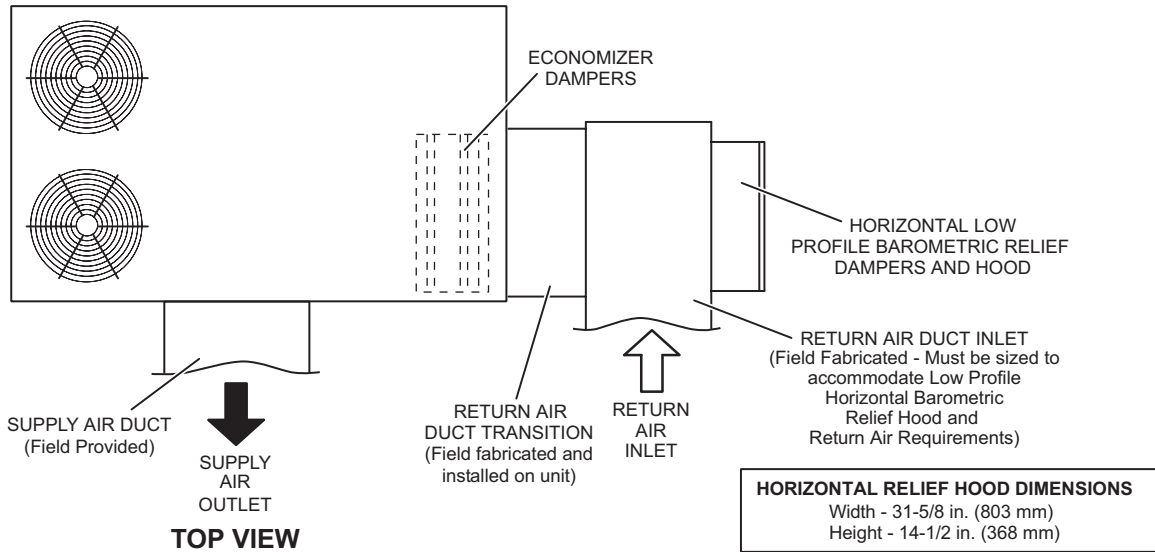

**NOTE** - Return Air Duct and Transition must be supported.

**HORIZONTAL LOW PROFILE BAROMETRIC RELIEF DAMPERS**  
(Field installed in horizontal return air duct adjacent to unit)

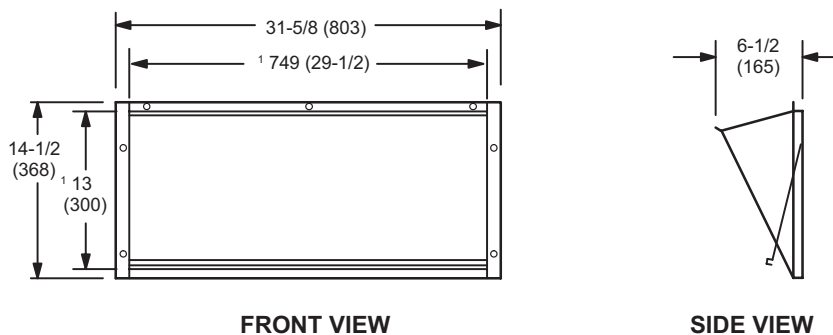

<sup>1</sup> NOTE - Opening size required in return air duct.

**HYBRID ROOF CURBS - DOUBLE DUCT OPENING**

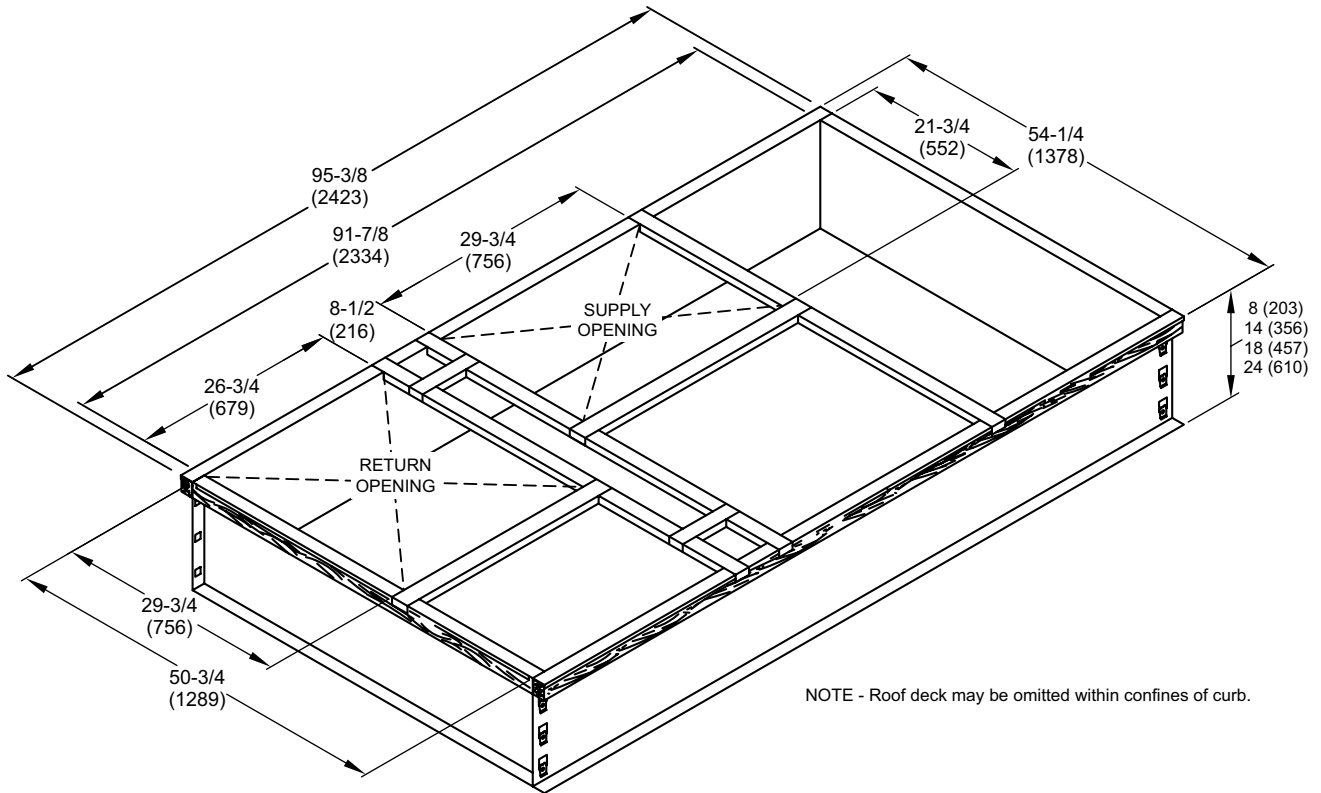

**TYPICAL FLASHING DETAIL FOR ROOF CURB**

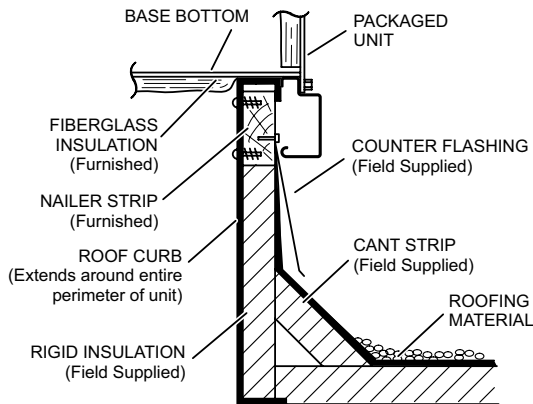

**DETAIL ROOF CURB**

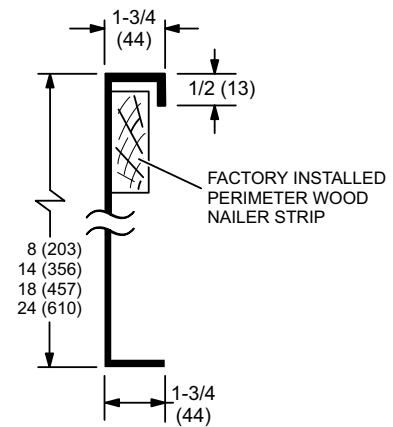

**ADJUSTABLE PITCH CURBS - DOUBLE DUCT OPENING**

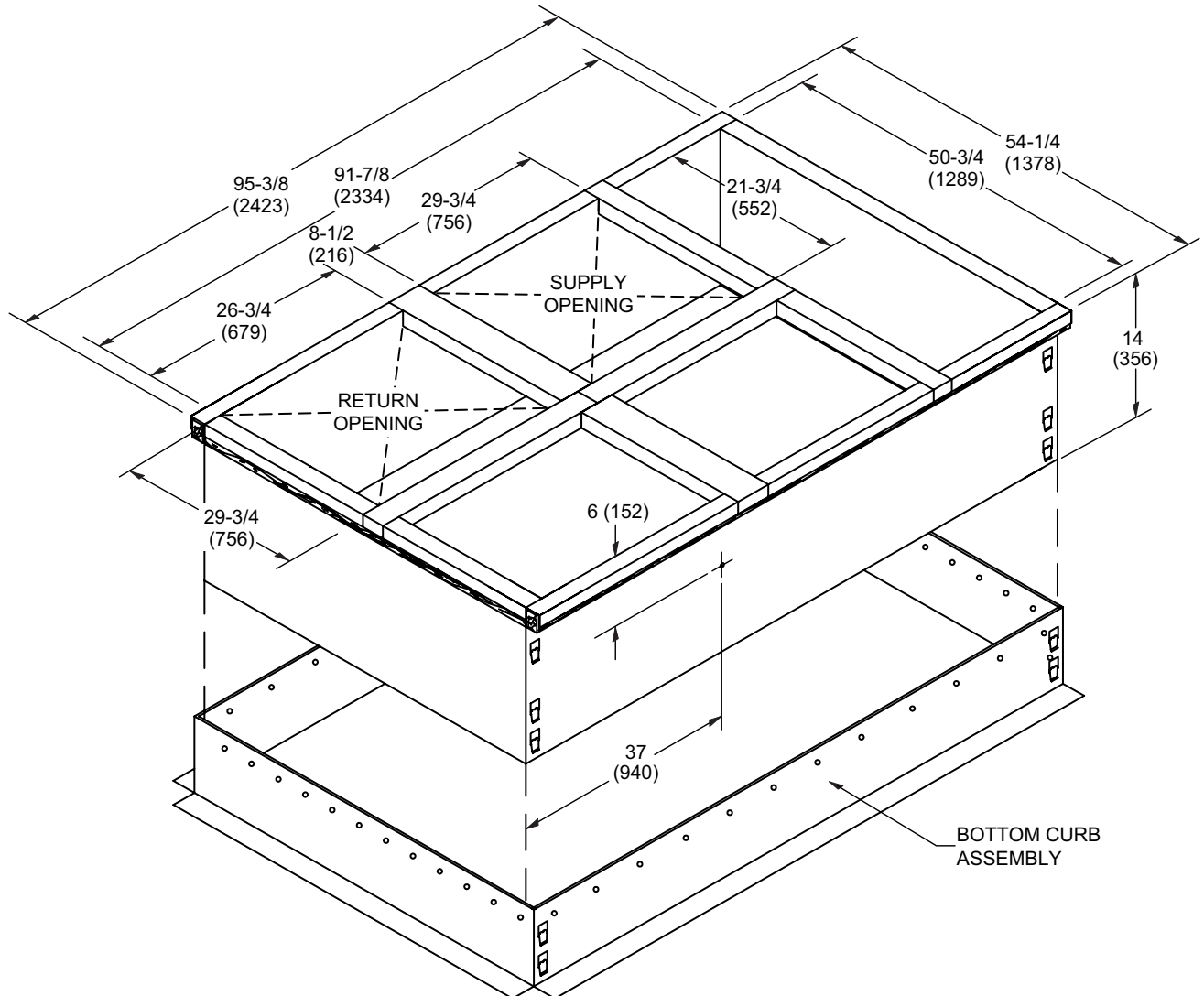

NOTE - Maximum slope pitch is 3/4 in. per 1 foot (19 mm per 305 mm) in any one direction.

**TYPICAL FLASHING DETAIL FOR ROOF CURB**

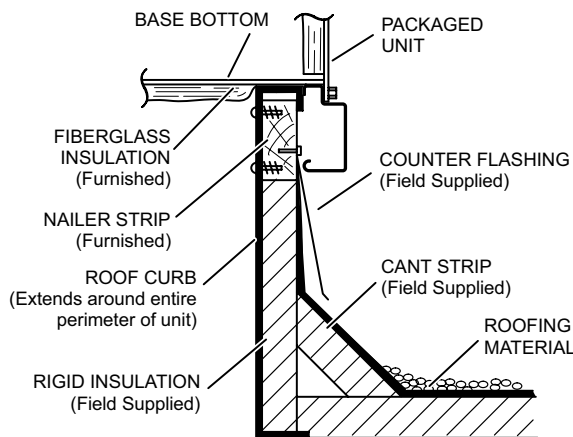

**DETAIL ROOF CURB**

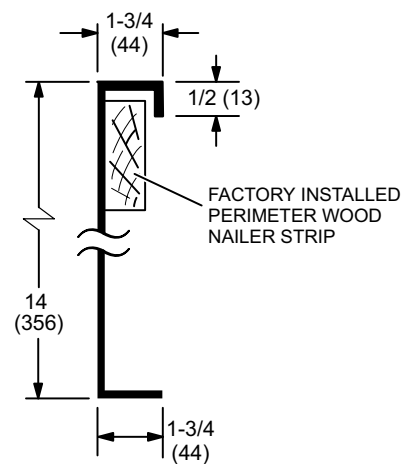

ROOF CURBS WITH SUPPLY & RETURN AIR TRANSITIONS FOR CEILING DIFFUSERS

**C1DIFF30B-1 ROUND TRANSITIONS**  
(for 092 models)

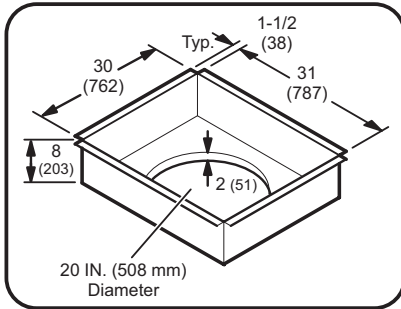

**C1DIFF31B-1 & C1DIFF32B-1 RECTANGULAR TRANSITIONS**  
(for 102 thru 150 models)

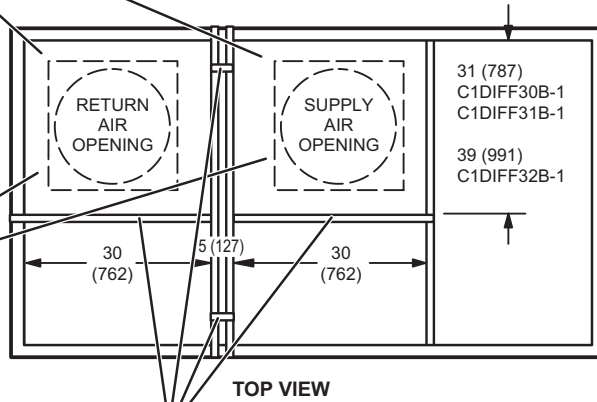
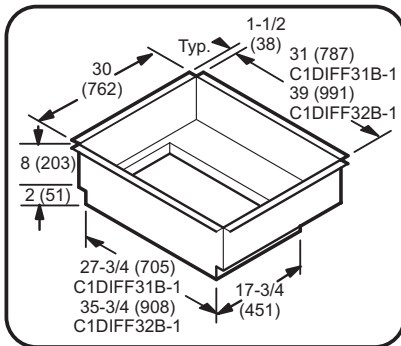

TOP VIEW

NOTE - These four supports are furnished with the transitions to replace supports furnished with curb for proper transition spacing.



**COMBINATION CEILING SUPPLY AND RETURN DIFFUSERS**  
**STEP-DOWN CEILING DIFFUSER**

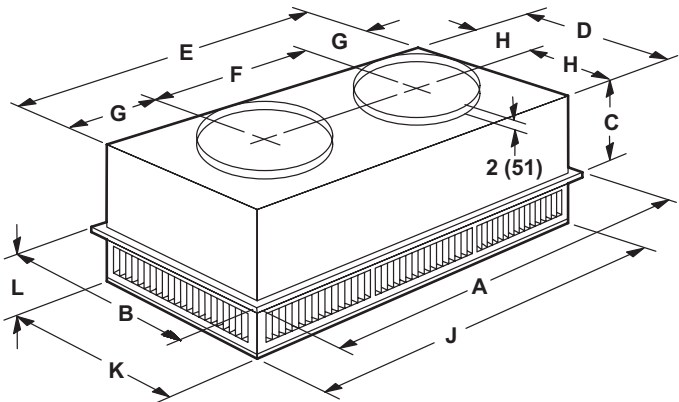

**FLUSH CEILING DIFFUSER**

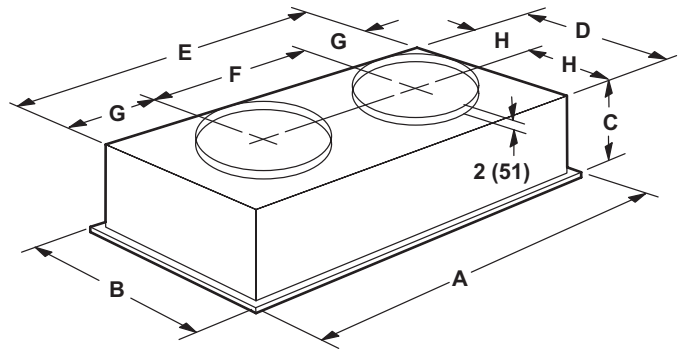

Model Number		RTD11-95S
A	in.	47-5/8
	mm	1159
B	in.	29-5/8
	mm	752
C	in.	14-3/8
	mm	365
D	in.	27-1/2
	mm	699
E	in.	45-1/2
	mm	1158
F	in.	22-1/2
	mm	572
G	in.	11-1/2
	mm	292
H	in.	13-3/4
	mm	349
J	in.	45-1/2
	mm	1156
K	in.	27-1/2
	mm	699
L	in.	8-1/8
	mm	206
Duct Size	in.	20 round
	mm	508 round

Model Number		FD11-95S
A	in.	47-5/8
	mm	1159
B	in.	29-5/8
	mm	752
C	in.	16-5/8
	mm	422
D	in.	27
	mm	686
E	in.	45
	mm	1143
F	in.	22-1/2
	mm	572
G	in.	11-1/4
	mm	286
H	in.	13-1/2
	mm	343
Duct Size	in.	20 round
	mm	508 round

**COMBINATION CEILING SUPPLY AND RETURN DIFFUSERS**

**STEP-DOWN CEILING DIFFUSER**

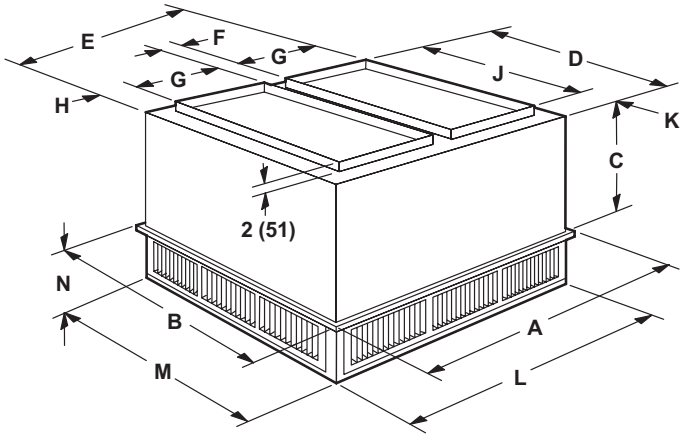

**FLUSH CEILING DIFFUSER**

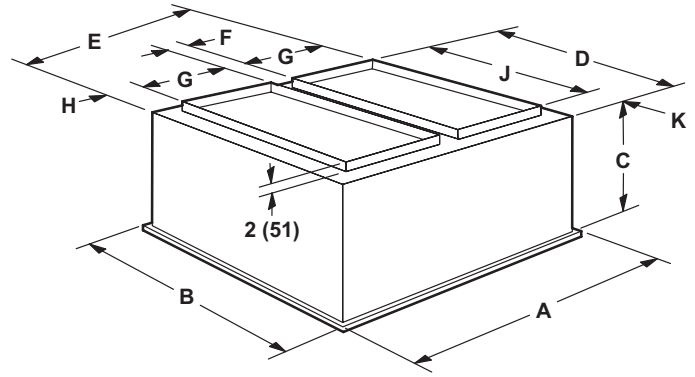

Model Number		RTD11-135S	RTD11-185S
A	in.	47-5/8	47-5/8
	mm	1210	1210
B	in.	35-5/8	47-5/8
	mm	905	1210
C	in.	20-5/8	24-5/8
	mm	524	625
D	in.	33-1/2	45-1/2
	mm	851	1156
E	in.	45-1/2	45-1/2
	mm	1156	1156
F	in.	4-1/2	4-1/2
	mm	114	114
G	in.	18	18
	mm	457	457
H	in.	2-1/2	2-1/2
	mm	64	64
J	in.	28	36
	mm	711	914
K	in.	2-3/4	4-3/4
	mm	70	121
L	in.	45-1/2	45-1/2
	mm	1156	1156
M	in.	33-1/2	45-1/2
	mm	851	1156
N	in.	9-1/8	10-1/8
	mm	232	257
Duct Size	in.	18 x 28	18 x 36
	mm	457 x 711	457 x 914

Model Number		FD11-135S	FD11-185S
A	in.	47-5/8	47-5/8
	mm	1210	1210
B	in.	35-5/8	47-5/8
	mm	905	1210
C	in.	23-1/4	29-1/4
	mm	591	743
D	in.	33	45
	mm	838	1143
E	in.	45	45
	mm	1143	1143
F	in.	4-1/2	4-1/2
	mm	114	114
G	in.	18	18
	mm	457	457
H	in.	2-1/4	2-1/4
	mm	57	57
J	in.	28	36
	mm	711	914
K	in.	2-1/2	4-1/2
	mm	64	114
Duct Size	in.	18 x 28	18 x 36
	mm	457 x 711	457 x 914



## REVISIONS

Sections	Description of Change
Sound Data	Updated.
Weight Data	Updated for 150 model.

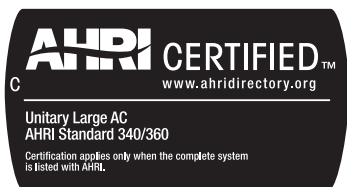

Visit us at [www.lennox.com](http://www.lennox.com)

For the latest technical information, [www.lennoxcommercial.com](http://www.lennoxcommercial.com)

Contact us at 1-800-4-LENNOX

NOTE - Due to Lennox' ongoing commitment to quality, Specifications, Ratings and Dimensions subject to change without notice and without incurring liability. Improper installation, adjustment, alteration, service or maintenance can cause property damage or personal injury. Installation and service must be performed by a qualified installer and servicing agency.

©2021 Lennox Industries, Inc.