



Single Zone Ductless Air Conditioning Systems - R-410A - 60 Hz

MCA

Mini-Split

**RESIDENTIAL / COMMERCIAL
PRODUCT SPECIFICATIONS**

Bulletin No. 210877
May 2020
Supersedes April 2020



**MWCA Wall-Mounted
Ductless Indoor Unit**

**Wireless
Remote Control
(furnished with
Wall-Mount Model)**



**MCA Outdoor Air
Conditioning Unit**

**SEER - Up to 20.00
0.75 to 2 Tons
Cooling Capacity - 9,000 to 22,000 Btuh**

MODEL NUMBER IDENTIFICATION

OUTDOOR SINGLE ZONE AIR CONDITIONING UNITS

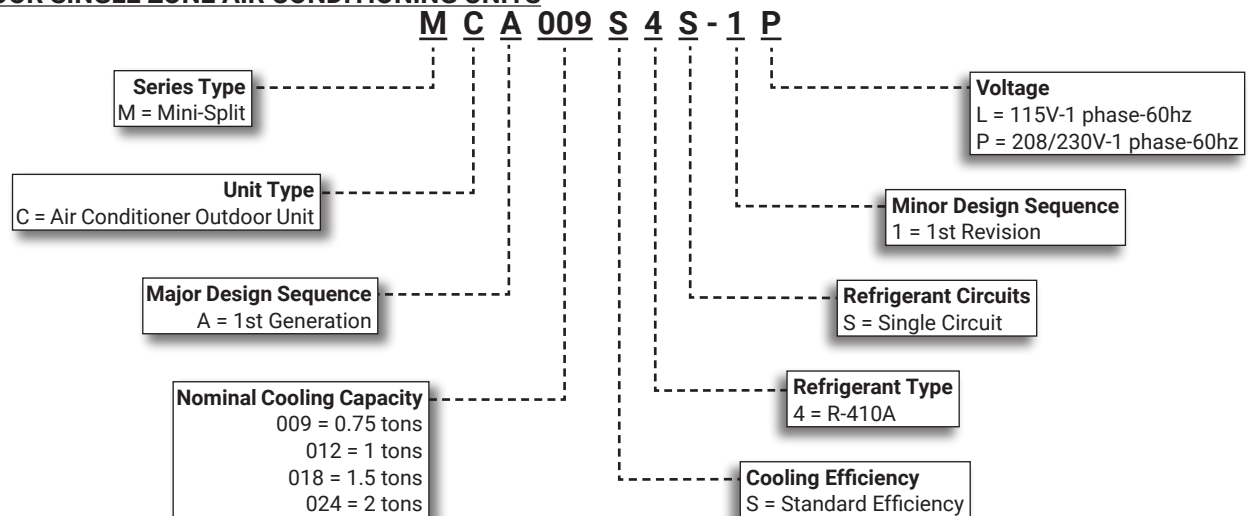

WALL-MOUNTED INDOOR UNITS

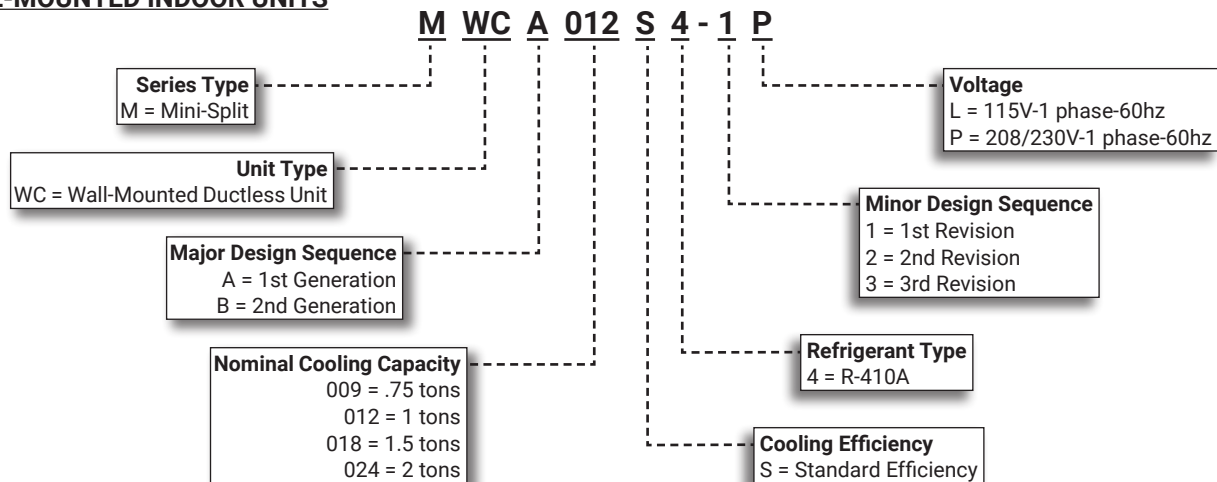

CONTENTS

AHRI System Matches	13
Air Throw Data.	19
Approvals And Warranty	3
Cooling Capacity	16
Dimensions - Outdoor Units	20
Dimensions - Wall-Mounted Indoor Units.	21
Dimensions - Wall-Mounted Indoor Units - Wall Plates	21
Features - Indoor Units	5
Features - Outdoor Units	3
Installation Clearances - Outdoor Units.	23
Installation Clearances - Wall-Mounted Indoor Units	24
Line Set And Elevation Guidelines.	24
Model Number Identification.	2
Optional Accessories - Order Separately	14
Sound Levels - Test Conditions	15
Specifications - Outdoor Units.	12
Specifications - Wall-Mounted Indoor Units	13

APPROVALS AND WARRANTY

APPROVALS

- AHRI Standard 210/240 certified with Addenda 1 and 2
- ENERGY STAR® certified (certain models)
- Rated According to U.S. Department of Energy (DOE) test procedures
- Indoor and outdoor units and components UL and CEC bonded for grounding to meet safety standards for servicing
- ETL certified for the U.S. and Canada
- Meets 2014 Florida Building Code Wind Design Criteria
 - Ultimate Wind Speed – 186 miles per hour
 - Risk Categories – III and IV
 - Wind Exposures – C and D
 - Mean Roof Heights – Up to 60 feet above ground

WARRANTY

- Compressor - Limited five years
- All other covered components - Limited five years

NOTE - Refer to Lennox Equipment Limited Warranty certificate included with unit for specific details.

FEATURES - OUTDOOR UNITS

APPLICATIONS

- SEER - Up to 20.00
- 0.75 through 2 ton
- Single phase power supply
- 115V (012 model only)
- 208/230V (all models)
- Outdoor unit sound levels as low as 51 dBA
- Indoor unit sound levels as low as 24.5 dBA
- Ductless mini-split systems provide a wide range of capacities and applications and provide an alternative when a ducted system is impractical or cost prohibitive
- Units shipped completely factory assembled, internally piped, and wired.

NOTE - Outdoor unit is designed for outdoor use.

REFRIGERATION SYSTEM

R-410A Refrigerant

- Non-chlorine, ozone friendly
- Unit is factory pre-charged

Outdoor Coil

- Aluminum fins fitted to copper tubes
- Wire grille guard provided

Outdoor Fan

- Direct drive fan moves large air volumes uniformly through entire outdoor coil for high refrigeration capacity
- Fan guard provided

Refrigerant Line Connections, Service Valve

- Flare connection lines are located on side of unit cabinet
- Fully serviceable brass service valve prevents corrosion and provides access to refrigerant system

COMPRESSOR

Variable Frequency Rotary Compressor

- Compressor features high efficiency operation
- Balanced for reduced vibration and quiet operation
- Brushless DC motor uses powerful Neodymium magnets, which are approximately 15-20 times stronger than ferrite magnets used in conventional AC compressors

Compressor Crankcase Heater

- Protects against liquid refrigerant migration that can occur during low ambient operation

CONTROLS

DC Inverter Control

- Provides continuous operation, while adjusting capacity according to room temperature
- The accurate sensing of cooling loads prevents frequent changes in capacity and ensures efficient, economical operation

Inverter Module Protection

- Protects against differences in current, voltage and temperature
- Displays code on the indoor unit indicating a need for servicing

Outdoor Unit Microprocessor

- Electronic expansion valve control
- Automatic compressor timed-off protection (3 minutes)
- Temperature sensor
- LEDs on control display error codes and assist in troubleshooting

FEATURES - OUTDOOR UNITS

CONTROLS (continued)

Capillary Tube Refrigerant Metering

- Refrigerant metering device consisting of small diameter tubes feeding liquid refrigerant into the evaporator coil
- Furnished on all units

Compressor Overcurrent Protection

- Overcurrent protection can result due to any of the following:
 - Ambient temperature is too high
 - Locked rotor on the compressor
 - Outdoor air is blocked or restricted

Condenser High Temperature Protection

- Condenser high temperature can occur due to any of the following conditions:
 - High outdoor ambient
 - Outdoor fan blocked
 - Outdoor coil blocked
- The outdoor coil thermistor continuously monitors the temperature and communicates with the microprocessor
- Depending on the temperature measured, the compressor will be allowed to increase the frequency if needed to meet the load or is forced to run at the current or reduced frequency
- If the temperature becomes excessively high the compressor will be de-energized

Compressor Discharge Temperature Protection

- The compressor discharge line thermistor continuously monitors the temperature and communicates with the microprocessor
- Depending on the temperature measured, the compressor will be allowed to increase the frequency to meet the load or is forced to run at the current or reduced frequency
- If the temperature becomes excessively high, the compressor will be de-energized

Voltage Protection

- Protects unit from low or high voltage fluctuations

Terminal Strip

- Furnished for easy wiring connections

CABINET

- Constructed of heavy gauge steel
- Tabs on unit base allow secure mounting to slab
- Condensate drain outlets furnished on unit base

NOTE - Drain must be field furnished.

- Access cover for power and control wiring connections
- Access cover for service valves

FEATURES - INDOOR UNITS

WALL-MOUNTED INDOOR UNITS



- Low-sound, three-speed Wall Mount with LED display offers three access points for refrigerant outlet pipes: left, right or rear
- The front panel can be raised for accessible wiring and maintenance
- Swing louver angles to 90°
- Unit installs horizontally on a vertical wall
- **LED Readout** - Mounted on unit. LED displays unit operation status, and codes for maintenance and servicing
- **Auto Restart** - Automatically restores the previous function setting if power is interrupted
- **Cooling Override** - Button on the indoor unit allows a temporary 30 minute override of the system for forced "AUTO" or "COOLING" operation
- **Flare Connections** - Equipped with liquid and gas flare fittings for quick and secure piping
- **Multi-Refrigerant Outlet** - Allows left, right, or rear access for refrigeration line connection
- **Three Speed Fan** - Fan functions at three speeds: low, medium and high
- **Air Filter** - Cleanable air filter is furnished as standard

ACCESSORIES (FURNISHED)

WIRELESS REMOTE CONTROLLER

Furnished with Indoor Unit.

- Complete remote control of system
- Maximum operating range is 25 ft.
- Operates on two AAA 1.5V batteries (furnished)
- Wireless remote controller holder furnished
- Holder can be mounted on a wall for easy access
- Mounting screws furnished

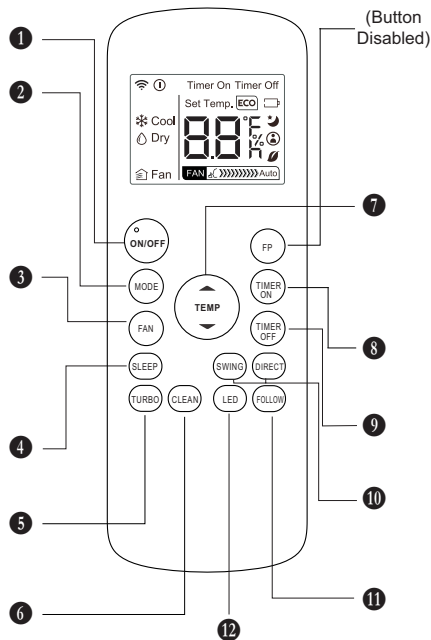

- 1 ON/OFF Button**
 - Turns system on and off
- 2 MODE Button**
 - Select system operation modes. Push button to cycle through each setting
- 3 FAN Button**
 - Select fan speed. Push button to cycle through each setting

COOL → DRY → FAN

AUTO → LOW → MED → HIGH

NOTE - Hold button for 2 seconds to activate Silence function. Operates the compressor at low frequency and low fan speed to reduce operating sound levels to a minimum. Hold FAN button for 2 seconds to cancel.
- 4 SLEEP Button**
 - Enables the system to automatically increase cooling (in 2°F increments) per hour for the first 2 hours, then maintain a steady temperature for 5 hours
 - System shuts off after 7 total hours of operation

NOTE - To cancel, push the "MODE", "FAN SPEED" or "ON/OFF" buttons.

NOTE - SLEEP mode is only available when the unit is in COOL mode.

- 5 TURBO Button**
 - Enables the unit to reach the preset temperature during cooling operation in the shortest time.
- 6 CLEAN Button**
 - Automatically cleans and dries the evaporator coil at the end of the cooling season, preventing any odors or mildew.

NOTE - CLEAN mode is only available in COOL or DRY mode.
- 7 UP/DOWN Buttons ▲ ▼**
 - Increase or decrease the indoor temperature in one degree increments (maximum 86°F, minimum 62°F).

NOTE - Temperature cannot be adjusted in FAN mode.

NOTE - Press and hold and buttons together for 3 seconds to alternate the temperature display between the °F and °C scale.
- 8 TIMER ON / TIMER OFF Buttons**
 - TIMER ON (initiates an auto-on time sequence)
 - TIMER OFF (initiates an auto-off time sequence)
 - Can be used separately or together
 - Each press of the button increases the time in 30 minute increments up to 10 hours
 - Above 10 hours each press of the button will increase the auto-timed setting by 60 minutes up to 24 hours

NOTE - To cancel, set timer to 0.0 or turn remote off and on.
- 9 SWING Button**
 - Used to start or stop horizontal (up/down) louver auto-swing feature
- 10 DIRECT Button**
 - Used to change the louver movement and set the desired up/down air flow direction
 - The louver angle changes 6° for each press of the button
- 11 FOLLOW Button**
 - Allows remote temperature sensing of the room at the remote controller location
- 12 LED Button**
 - Turns the LCD display backlight on the indoor unit on or off

ACCESSORIES (FURNISHED)

WIRELESS REMOTE CONTROLLER OPERATION

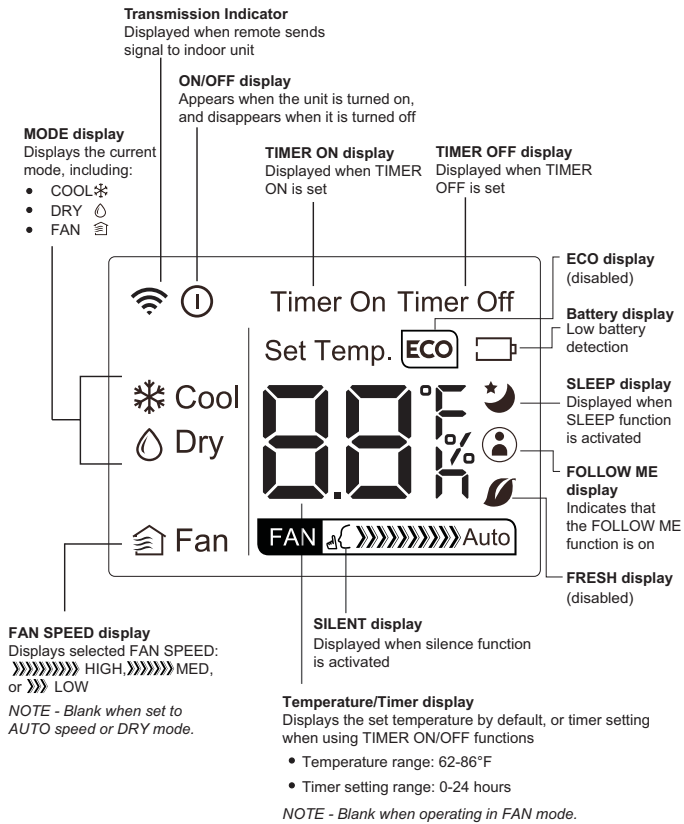

Cooling Operation

1. Press the **MODE** button to select **COOL** mode.
2. Press the **ON/OFF** button to start the air conditioner.

DRY (Dehumidifying) Operation

1. Press the **MODE** button to select **DRY** mode.
2. Press the **UP/DOWN** buttons to set the desired temperature.
3. Press the **ON/OFF** button to start the air conditioner.

NOTE - Fan speed cannot be changed in DRY mode.

Fan Operation

1. Press the **MODE** button to select **FAN** mode.
2. Press the **FAN** button to select the fan speed in four steps- Auto, Low, Med, or High.
3. Press the **ON/OFF** button to start the air conditioner.

NOTE - Temperature settings are disabled during fan only operation.

Timer ON/OFF Operation

1. Press the **TIMER ON** or **TIMER OFF** button. The remote controller shows **TIMER ON** or **TIMER OFF**, the previous Auto-on time setting and the signal "h" (indicating hours) will be shown on the LCD display area.
2. Push the **TIMER ON** or **TIMER OFF** button again to set desired time. Each time you press the button, the time increases by 30 minutes between 0 and 10 hours and by 60 minutes between 10 and 24 hours.
3. After setting the **TIMER ON** or **TIMER OFF** there will be a one second delay before the remote controller transmits the signal to the unit. After approximately 2 seconds, the signal "h" (indicating hours) will disappear and the set temperature will re-appear on the LCD display window.

OPTIONAL ACCESSORIES - ORDER SEPARATELY

WIRED PROGRAMMABLE CONTROLLER

M0STAT64Q-1



- Wired programmable local controller for mini-split indoor units with convenient timed schedules for daily operation
- Up to 8 events per day
- Schedule start time, mode, setpoint, and fan speed
- Compatible with all indoor units
- Copy/paste function for easy duplication of events to other days
- Built-in system diagnostics
- Large, back-lit, easy-to-read LCD screen with digital display

BUTTONS AND FUNCTIONS

POWER Button

- Turn system on and off

FAN SPEED Button

- Scroll through fan speeds (Auto - Low - Med - High)

MODE Button

- Use + and – buttons to scroll through available operation modes (Auto / Cool / Dry / Fan / Heat)

NOTE - HEAT and AUTO modes are not available on air conditioner models.

PLUS (+) and MINUS (-) Buttons

- Setpoint adjustment (62-86°F)
- Select days of the week when setting a schedule
- Select mode of operation

SWING Button

- Stop or start horizontal (up/down) louver auto swing
- Controls swing oscillation and louver angle in 6° increments

TIMER Button

- Sets current time of day (24 hour clock)
- Setup weekly schedules or to setup timed operation for the indoor unit
- Stop/Stop timed operation

DAY OFF / DEL Button

- Disable specific days/schedules of the week
- Delete a specific event

CONFIRM Button

- Confirms each step when managing schedules

BACK/TURBO Button

- Turbo sets indoor unit fan speed to high for a factory-set time period

COPY/FOLLOW ME Button

- Toggles between room temperature sensing from the indoor unit or the controller

DISPLAY

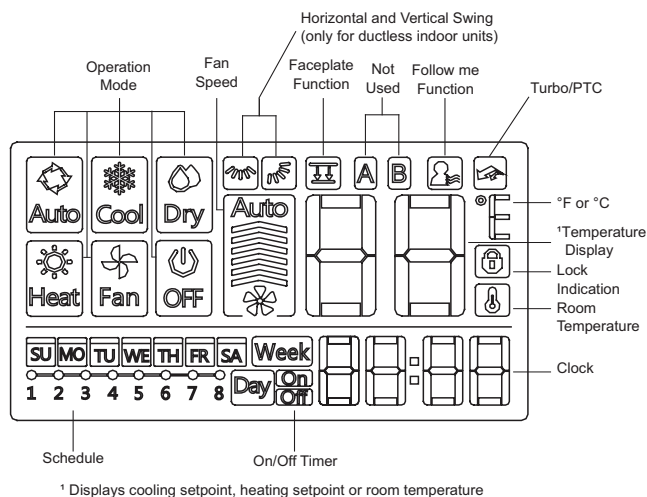

- Audible tone when a button is pressed (can be disabled)
- Lock function disables buttons to prevent tampering
- Controller uses 4-wire shielded 20 ft. (6 m) cable (furnished) for easy low voltage connection to the indoor unit
- Adaptor cables are furnished for various indoor unit connections

NOTE - Cable for longer lengths must be ordered separately.

NOTE - Maximum cable length is 164 ft. (50 m).

- Hardware for mounting furnished
- Mounts to standard electrical junction box (not furnished)
- Lithium battery furnished
- Power Supply: 5 VDC
- Dimensions (H x W x D): 4-7/8 x 4-3/4 x 3/4 in. (124 x 121 x 19 mm)

OPTIONAL ACCESSORIES

Extension Cable for Wired Programmable Controller

- 20 ft. cable for easy low voltage connection to the indoor unit
- Extends cable to 40 ft. (12 m) length

OPTIONAL ACCESORIES - ORDER SEPARATELY

WIRED NON-PROGRAMMABLE CONTROLLER

M0STAT61Q-1



- Permanent Memory - Maintains clock, fan speed and mode of operation settings following power outages
- Dimensions (H x W x D) - 4-3/4 x 4-3/4 x 7/8 in.
- Additional hardware is furnished for installation
- Controller uses 5-wire shielded 20 ft. (6 m) cable (furnished) for easy low voltage connection to the indoor unit

NOTE - Maximum cable length is 40 ft. (12 m).

DISPLAY

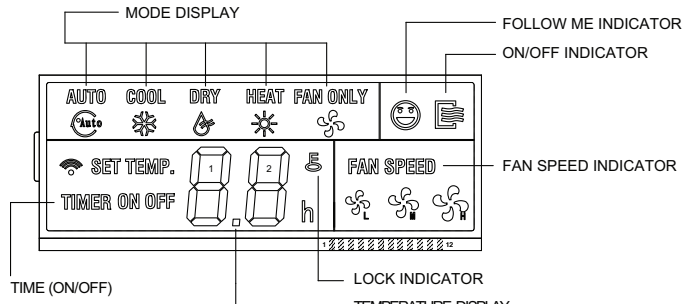

BUTTONS AND FUNCTIONS

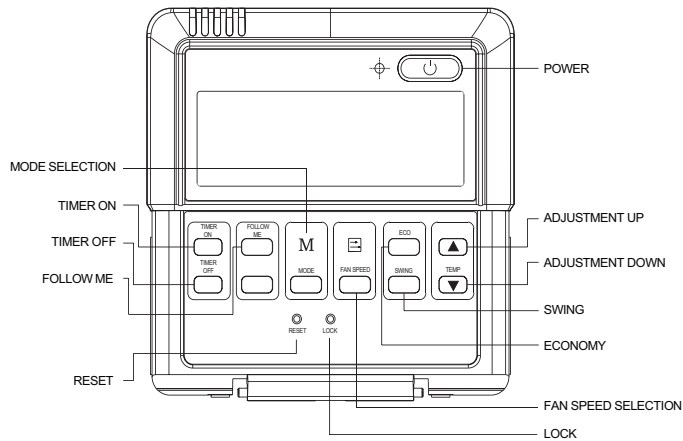

MODE Button

- Select system operation modes. Push button to cycle through each setting



POWER Button

- Turns system on and off

Fan Speed Button

- Selects fan speed. Each button press cycles through the following settings on display

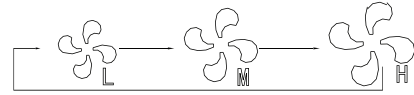

NOTE - Not available in AUTO mode.

TIMER ON / TIMER OFF Buttons

- TIMER ON (initiates an auto-on time sequence)
- TIMER OFF (initiates an auto-off time sequence)
- Can be used separately or together
- Each press of the button increases the time in 30 minute increments up to 10 hours
- Above 10 hours each press of the button will increase the auto-timed setting by 60 minutes up to 24 hours

NOTE - To cancel, set timer to 0.0.

UP / DOWN Buttons ▲ ▼

- Increase or decrease the indoor temperature in two degree increments (maximum 88°F, minimum 62°F)

NOTE - Temperature cannot be adjusted in FAN mode.

NOTE - Press and hold and buttons together for 3 seconds to alternate the temperature display between the °C and °F scale.

SWING Button

- Used to stop or start horizontal louver auto swing feature

ECONOMY Button

- Maintains the most comfortable temperature and saves energy

RESET Button (Recessed)

- Resets Controller to factory settings. Recessed to prevent tampering.

LOCK Button (Recessed)

- Locks Controller buttons to prevent tampering with settings.

OPTIONAL ACCESSORIES

Extension Cable for Wired Remote Controller

- 20 ft. cable for easy low voltage connection to the indoor unit
- Extends cable to maximum 40 ft. (12 m) length

OPTIONAL ACCESORIES - ORDER SEPARATELY

OUTDOOR UNITS

Condenser Pad

- Provides permanent foundation for outdoor units
- One-piece lightweight structural foam and molded from high-density polyethylene (HDPE)
- Lightweight, easy to carry and install
- Textured finish provides a non-skid surface so outdoor unit sits securely in one place
- UV stable

Disconnects

- Positive unit disconnect
- Single door enclosure
- Fused and non-fused models available

Fuses

- 30 and 60 amp fuses available

Hail Guards

- Protects outdoor coils on all sides without inhibiting airflow or performance
- Self-tapping screws provided for installation
- Flat shape allows for outdoor units to be placed close together
- Each kit contains all required guards
- Order one hail guard kit per outdoor unit module

Indoor/Outdoor Wiring Cable

- 14-gauge, 4-conductor wire
- THHN (Thermoplastic High Heat-resistant Nylon-coated) wire
- Suitable for wet or dry locations
- Rated up to 600V

Refrigerant Line Sets

- Refrigerant lines are shipped refrigeration clean
- Lines are cleaned, dried, pressurized and sealed at factory

Wall Brackets

- Heavy duty 1/8 in. thick steel brackets for supporting outdoor units
- Mount at any height to allow for easy maintenance under units
- Pre-punched holes for easy installation
- Powder coated gray finish
- Load rating 600 lbs. per pair

Whips

- Heavy duty electrical whips are available in 8 and 10 gauge sizes
- 6 ft. lengths
- Weatherproof metal conduit

INDOOR UNITS

Condensate Pumps

- Quietly and efficiently removes condensate
- See Optional Accessories Table for available pumps

A/C Easy Tee® Condensate Cleanout

- Condensate drain service port
- Flexible and easy to use with nitrogen, water or shop vac
- Screw cap on top allows easy access to condensate drain line

SPEEDICHANNEL™ SYSTEM



- SpeediChannel™ is a channel system covers system line sets
- Two-part system has a base and a cover
- Base is fastened to a wall or ceiling with plastic clips (SpeediClip™) that snap into a channel already molded into the base
- Cover fits on top of the base
- Manufactured from rigid PVC, which is UL rated and resistant to UV light
- System is a natural color that closely matches typical mini-split outdoor units
- Can be painted as desired to match any wall color

Typical Application

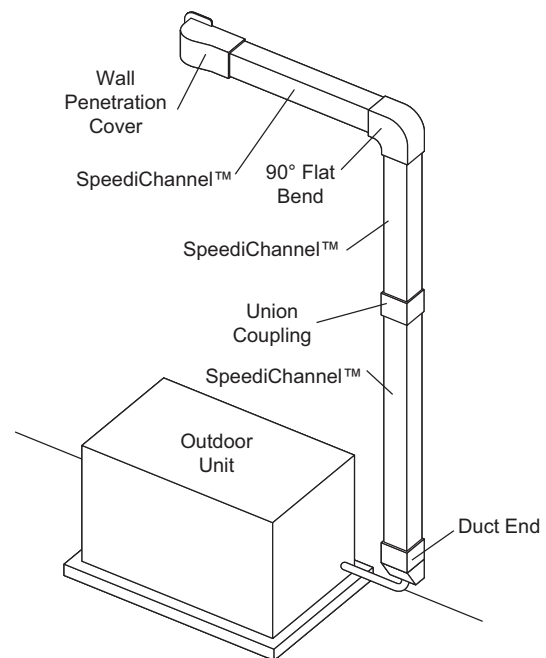

OPTIONAL ACCESORIES - ORDER SEPARATELY

SPEEDICHANNEL™ SYSTEM (continued)

SpeediChannel™ Starter Kit

- The starter kit includes (1) Coupling, (1) Wall Penetration, (1) Inside Elbow, (1) Long Radius Flat Bend, (10) Speediclips™, (10) 11 in. Cable Ties, and (1) SpeediChannel Instruction Booklet

Duct End

- Duct Ends are used to terminate a run of SpeediChannel™ to a small opening just large enough for the line set and condensate drain line to pass through



Flat Wall Escutcheon

- Flat Wall Escutcheons are used to cover a rough opening in a soffit, wall, or ceiling penetration



- One side of the escutcheon is flat to allow for a SpeediChannel™ to run along a wall and to penetrate through an adjacent wall or ceiling
- This is the most common type of wall penetration
- Furnished in two parts, the escutcheon easily snaps onto the SpeediChannel™

Flex Joint

- A Flex Joint is an accordion-style piece of SpeediChannel™
- The flex joint can be extremely flexible when routing a SpeediChannel™ system around an obstacle
- Each joint is 20 in. long and can be combined together for longer flex runs
- The flex joint does not require the use of a union coupling
- The flex joint slides tightly inside the SpeediChannel™ system

T-Joint

- T-Joints are used for creating a tee connection between three pieces of SpeediChannel™
- Each tee is individually packed and furnished with stainless steel screws

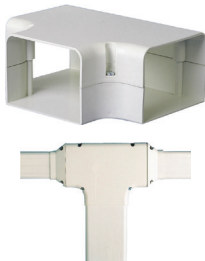

Union Coupling

- Union Couplings are used for joining two pieces of SpeediChannel™
- Each coupling is individually packed and furnished with stainless steel screws



Wall Penetration Cover

- Wall penetration covers are used to transition from the SpeediChannel™ system to a through wall penetration
- Wall covers are designed to allow for easy installation, even after the line set has been installed
- A hooking and fastening arrangement allows for quick installation
- Each wall cover is individually packed, and furnished with stainless steel screws to attach the wall cover to the base
- Three screws are necessary to fasten the wall cover to the wall construction, regardless of the type of installed system



45° and 90° Flat Bend Elbows

- 45° Flat Bends are used to route the SpeediChannel™ around obstacles
- Each bend is individually packed and furnished with stainless steel screws



45°



90°

90° Inside Elbow

- 90° Inside Elbows are used to route the SpeediChannel™ around an inside corner
- Each elbow is individually packed and furnished with stainless steel screws

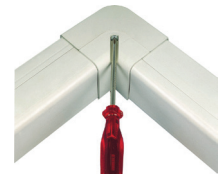

Mount Block White Qty. (2) 14 in. and (2) 36 in.

- Mount Blocks are used as mounting bases when outdoor units must be bolted down
- End caps (for aesthetics) come furnished with mounting bolts
- Maximum load capacity is 900 pounds per mounting block
- Installation temperatures range from -4°F to 140°F
- Mount blocks fit all mini-split outdoor units with a sliding rail feature



SPECIFICATIONS - OUTDOOR UNITS

Outdoor Unit Model No.	MCA009S4S	MCA012S4S	MCA018S4S	MCA024S4S	
Nominal Size - Tons	0.75	1	1.5	2	
Ambient Temperature Operating Range - °F	5 - 122	5 - 122	5 - 122	5 - 122	
Energy Star	No	No	No	No	
Sound Data (dBA)	51	51.5	53.5	57	
Refrigerant (R-410A)	Charge furnished (115V)	---	1 lb. 5 oz.	---	
	Charge furnished (208/230V)	1 lb. 2 oz.	1 lb. 3 oz.	2 lbs. 0 oz.	
	Maximum line length with furnished charge - ft.	25	25	25	
	Additional charge required per ft. - oz.	0.16	0.16	0.16	
Compressor	No. and Type	(1) Rotary	(1) Rotary	(1) Rotary	
	Refrigerant oil type	VG74	VG74	VG74	
	Refrigerant oil charge - oz.	5.7	12.5 (115V) 5.7 (208/230V)	14.9	
Connections - in.	Liquid/Gas pipe (flare)	1/4 / 3/8	1/4 / 1/2	1/4 / 1/2	
	Maximum refrigerant pipe length - ft.	82	82	98	
	Max. difference in level of indoor unit - ft.	33	33	66	
Outdoor Fan	(No.) Diameter - in.	(1) 16-3/4	(1) 16-3/4	(1) 16-3/4	
	Total air volume - cfm	1230	1175 (115V) 1230 (208/230V)	1195	
	rpm	850/700	850/700	850/700	
Outdoor Coil	Number of rows	1	1	2	
	Fins per inch	21	21	21	
	Fin type	Hydrophilic aluminium			
	Tube outside diameter - in.	1/4	1/4	1/4	
	Tube type	Rifled copper tubing			
	Net face area - ft. ²	4.15	4.15	4.15	
	Application area - ft. ²	130 - 195	170 - 250 (115V) 160 - 240 (208/230V)	250 - 355	
Design Pressure	PSIG	550/340	550/340	550/340	
Shipping Data	Net/Shipping weight (lbs.) (115V)	---	63 / 68	---	
	(208/230V)	54 / 59	55 / 60	66 / 73	
ELECTRICAL DATA					
Electrical Characteristics - 60 Hz - 1 Phase	208/230V	115V	208/230V	208/230V	
¹ Maximum Overcurrent Protection (amps)	15	20	15	20	
² Minimum circuit ampacity	10	15	11	15	
Compressor Rated load amps	6.2	9.5	6.8	9.0	
Outdoor Fan Motor	Rated load amps	0.4	0.6	0.5	
	Output - W	58	58	58	

NOTE - Extremes of operating range are plus and minus 10% of line voltage.

¹ HACR type circuit breaker or fuse.

² Refer to National or Canadian Electrical Code manual to determine wire, fuse and disconnect size requirements.

SPECIFICATIONS - WALL-MOUNTED INDOOR UNITS

Indoor Unit Model No.	MWCA009S4	MWCA012S4		MWCA018S4	MWCA024S4
Nominal Size - Tons	0.75	1		1.5	2
Power Supply - 60 hz - 1 phase	208/230V	115V	208/230V	208/230V	208/230V
Rated load amps	0.22	0.43	0.22	0.40	0.40
Output (W)	47.4	46	47.4	36	89
Room Temperature Range (°F) Cooling	62 - 90	62 - 90	62 - 90	62 - 90	62 - 90
Air Volume - cfm (High/Medium/Low)	241/206/147	235/206/147	241/194/206	530/441/353	581/456/331
Sound Data (dBA) - Low/Medium/High	26.5/32/38	24.5/33/38.5	24.5/34.5/37.5	30.5/34.5/42	34/40.5/46
Piping Connections - Liquid/Gas - o.d. - flare - in.	1/4 / 3/8	1/4 / 1/2	1/4 / 1/2	1/4 / 1/2	3/8 / 5/8
Drain connection o.d. - in.	1	1	1	1	1
Net/Shipping weights - lbs.	17 / 22	19 / 25	18 / 24	26 / 31	32 / 40

AHRI SYSTEM MATCHES

Indoor Unit Type	Outdoor Unit	Indoor Unit	Cooling Capacity	SEER	EER	AHRI Reference
Wall-Mounted Ductless	MCA009S4S-1P	MWCA009S4-1P	9,000	19.00	11.10	202515503
	MCA012S4S-1L	MWCA012S4-1L	12,000	16.50	10.00	202515502
	MCA012S4S-1P	MWCA012S4-1P	11,500	19.00	11.10	202515504
	MCA018S4S-1P	MWCA018S4-1P	17,000	20.00	10.80	202515505
	MCA024S4S-1P	MWCA024S4-1P	22,000	19.00	10.90	202515506

Ratings are AHRI certified to AHRI Standard 210/240 with Addenda 1 and 2 (with 25 ft. of connecting refrigerant lines); 95°F outdoor air temperature, 80°F db / 67°F wb entering evaporator air.

OPTIONAL ACCESSORIES - ORDER SEPARATELY

Description	Catalog No.	Size				
		09	12	18	24	
OUTDOOR UNIT						
Condenser Pad (18 x 38 x 3)	Y5014	•	•	•	•	
Disconnects	30 amp, fused, 1 ph	27P37	•	•	•	
	60 amp, non-fused, 1 ph	27P39	•	•	•	
Fuses	30A	83P75	•	•	•	
	60A	83P77	•	•	•	
Hail Guards	M9GARD19Q-1	15D32	•	•	N/A	
	M9GARD15Q-1	15D26	N/A		•	
Line Sets	1/4 in. x 3/8 in. x 25 ft.	90X53	•	N/A		
	1/4 in. x 3/8 in. x 50 ft.	X0258	•	N/A		
	1/4 in. x 1/2 in. x 25 ft.	90X52	N/A	•	•	N/A
	1/4 in. x 1/2 in. x 50 ft.	X0259	N/A	•	•	N/A
	3/8 in. x 5/8 in. x 25 ft.	X8406	N/A		•	
	3/8 in. x 5/8 in. x 50 ft.	X8407	N/A		•	
Wall Brackets	30 inch	X1727	•	•	•	•
Whips	10 Gauge - 1/2 in. x 6 ft.	29P54	•	•	•	•
	8 Gauge - 3/4 in. x 6 ft.	27P44	•	•	•	•
INDOOR UNIT						
¹ Diversitech Condensate Pumps with Reservoir	ClearVue Mini™ - 7.9 US gallons per hour, 35 ft. lift - 120/240V	Y5170	•	•	•	•
	Mini-Split Pump - 4 US gallons per hour, 20 ft. lift - 115V	Y7946	N/A	•	N/A	
	Mini-Split Pump - 4 US gallons per hour, 20 ft. lift - 230V	Y7949	•	•	•	•
¹ Blue Diamond® Condensate Pumps with Reservoir	MicroBlue® - 1.3 US gallons per hour, 6 ft. lift - 110v-230V	14T74	•	•	•	N/A
	MaxiBlue® - 3.7 US gallons per hour, 16.5 ft. lift - 208-230V	14T69	N/A		•	
	MultiTank Kit	14T75	N/A		•	
	Sensor Cable Extension - 16 ft.	14T76	•	•	•	•
A/C Easy Tee® Condensate Cleanout		Y7947	•	•	•	•
CONTROLS						
Wired Programmable Controller	M0STAT64Q-1	15D30	•	•	•	•
Wired Non-Programmable Remote Controller	M0STAT61Q-1	14A66	•	•	•	•
Extension Cable for Wired Programmable Controller - 20 ft.	M0CTRL64Q-1	Y8738	•	•	•	•
Indoor/Outdoor Wiring Cable - 14 Gauge, 4 conductor wire, THHN, 250 ft.		Y2067	•	•	•	•
SPEEDICHANNEL™ SYSTEM						
SpeediChannel™ Starter Kit - 4 in.		Y3387	•	•	•	•
SpeediChannel - 4 in. x 6-1/2 ft. (qty. 6)		Y3388	•	•	•	•
Union Coupling - 4 in.		Y3389	•	•	•	•
90° Flat Bend Elbow - 4 in.		Y3390	•	•	•	•
90° Inside Elbow - 4 in.		Y3391	•	•	•	•
45° Flat Bend Elbow - 4 in.		Y3392	•	•	•	•
Flex Joint - 4 in.		Y3393	•	•	•	•
T-Joint - 4 in.		Y3394	•	•	•	•
Duct End - 4 in.		Y3395	•	•	•	•
Flat Wall Escutcheon - 4 in.		Y3396	•	•	•	•
Wall Penetration Cover - 4 in.		Y3399	•	•	•	•
Mount Block (White) Qty, 2 - 14 in.		Y3397	•	•	•	•
Mount Block (White) Qty, 2 - 36 in.		Y3398	•	•	•	•

¹ Y7946, Y7949 and 14T74 condensate pumps can be installed inside the indoor units. All other pumps must be installed external to the indoor unit.

SOUND LEVELS - TEST CONDITIONS

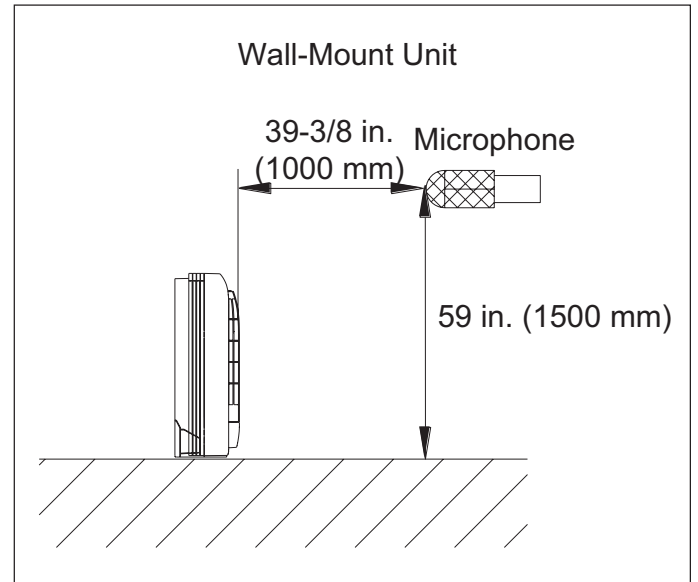
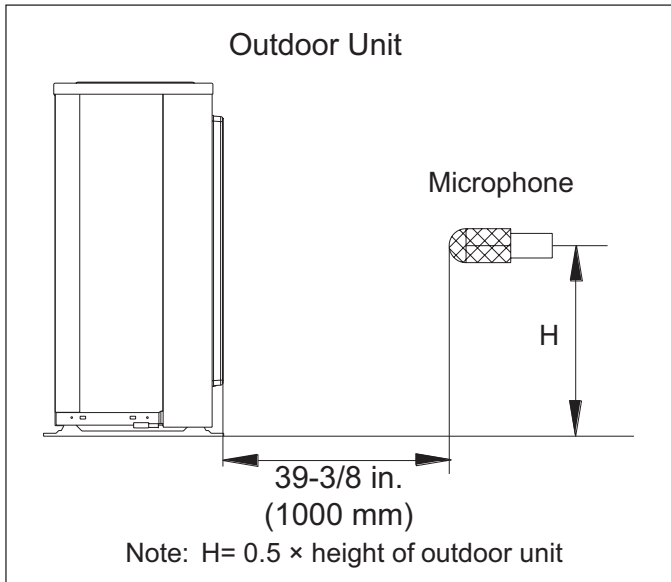

COOLING CAPACITY - 009 (208/230V)

Outdoor Temperature - °F (Dry Bulb)	Indoor Temperature - °F (Dry Bulb / Wet Bulb)							
	65°F / 54°F		70°F / 59°F		75°F / 63°F		80°F / 67°F	
	Total mBtuh	Sensible mBtuh	Total mBtuh	Sensible mBtuh	Total mBtuh	Sensible mBtuh	Total mBtuh	Sensible mBtuh
5	7.96	5.70	8.44	6.12	9.11	6.53	9.59	6.86
15	8.56	6.27	9.18	6.79	9.96	7.29	10.37	7.60
25	9.08	6.18	9.57	6.45	10.33	7.03	10.87	7.33
35	9.45	6.51	9.89	6.79	10.61	7.32	11.17	7.72
45	10.45	7.13	10.89	7.46	11.82	8.07	12.44	8.45
55	10.41	7.58	10.97	7.98	11.97	8.71	12.47	9.03
65	10.45	7.61	11.01	8.02	11.89	8.66	12.51	9.12
75	10.61	7.44	11.11	7.79	11.86	8.32	12.55	8.80
85	9.92	7.06	10.39	7.35	11.22	7.98	11.81	8.32
95	9.24	6.81	9.79	7.21	10.45	7.70	11.06	8.27
105	8.69	6.78	9.16	7.14	9.89	7.71	10.40	8.12
110	8.14	6.92	8.63	7.34	9.22	7.83	9.75	8.29
115	7.37	6.56	7.81	6.95	8.43	7.50	8.87	7.90
122	6.59	6.07	6.99	6.43	7.58	6.98	7.90	7.27

COOLING CAPACITY - 012 (115V)

Outdoor Temperature - °F (Dry Bulb)	Indoor Temperature - °F (Dry Bulb / Wet Bulb)							
	65°F / 54°F		70°F / 59°F		75°F / 63°F		80°F / 67°F	
	Total mBtuh	Sensible mBtuh	Total mBtuh	Sensible mBtuh	Total mBtuh	Sensible mBtuh	Total mBtuh	Sensible mBtuh
5	7.64	5.28	8.13	5.61	8.44	5.80	8.83	6.09
15	7.93	5.62	8.44	5.98	8.85	6.32	9.22	6.52
25	8.38	5.94	8.77	6.22	9.30	6.62	9.63	6.90
35	8.81	6.18	9.16	6.42	9.61	6.82	10.06	7.10
45	9.00	6.63	9.63	7.09	10.09	7.55	10.46	7.68
55	9.47	7.31	9.96	7.69	10.39	7.87	10.88	7.78
65	9.92	7.01	10.42	7.37	10.93	7.73	11.33	8.01
75	10.15	7.31	10.80	7.77	11.28	8.11	11.81	8.50
85	10.78	7.86	11.28	8.22	11.90	8.67	12.39	9.03
95	11.02	7.73	11.53	8.08	12.16	8.53	12.60	8.84
105	9.81	7.11	10.31	7.48	10.82	7.85	11.33	8.22
110	8.67	6.76	9.17	7.15	9.72	7.58	10.07	7.86
115	7.98	6.78	8.44	7.17	8.76	7.44	9.17	7.79
122	7.14	6.35	7.43	6.61	7.79	6.94	8.16	7.26

COOLING CAPACITY - 012 (208/230V)

Outdoor Temperature - °F (Dry Bulb)	Indoor Temperature - °F (Dry Bulb / Wet Bulb)							
	65°F / 54°F		70°F / 59°F		75°F / 63°F		80°F / 67°F	
	Total mBtuh	Sensible mBtuh	Total mBtuh	Sensible mBtuh	Total mBtuh	Sensible mBtuh	Total mBtuh	Sensible mBtuh
5	10.44	7.51	11.00	7.92	11.88	8.55	12.58	9.05
15	10.86	7.92	11.46	8.35	12.31	8.97	13.17	9.59
25	11.33	7.95	11.88	8.33	12.91	9.06	13.74	9.63
35	11.95	8.67	12.45	9.03	13.52	9.81	14.31	10.37
45	11.75	8.69	12.25	9.06	13.31	9.84	14.16	10.46
55	11.36	8.26	11.84	8.61	13.01	9.46	13.77	10.01
65	11.12	8.10	11.72	8.54	12.66	9.22	13.40	9.76
75	10.74	7.54	11.33	7.95	12.18	8.54	13.03	9.13
85	10.44	7.38	10.95	7.74	11.90	8.41	12.66	8.95
95	10.13	7.91	10.63	8.29	11.61	9.06	12.29	9.59
105	9.51	7.90	9.91	8.23	10.70	8.89	11.39	9.46
110	8.71	7.40	9.08	7.72	9.92	8.43	10.49	8.92
115	7.88	7.01	8.21	7.31	8.98	7.99	9.55	8.50
122	7.06	6.42	7.35	6.69	8.03	7.31	8.50	7.74

COOLING CAPACITY - 018 (208/230V)

Outdoor Temperature - °F (Dry Bulb)	Indoor Temperature - °F (Dry Bulb / Wet Bulb)							
	65°F / 54°F		70°F / 59°F		75°F / 63°F		80°F / 67°F	
	Total mBtuh	Sensible mBtuh	Total mBtuh	Sensible mBtuh	Total mBtuh	Sensible mBtuh	Total mBtuh	Sensible mBtuh
5	18.18	13.18	19.25	13.95	20.21	14.64	21.27	15.41
15	17.66	13.24	18.70	14.02	19.63	14.72	20.77	15.58
25	17.49	12.49	18.83	13.45	19.66	14.05	20.69	14.79
35	17.76	12.45	18.69	13.11	19.51	13.69	20.65	14.48
45	17.19	12.51	18.09	13.17	19.10	13.90	20.10	14.63
55	16.64	12.06	17.52	12.70	18.40	13.33	19.57	14.19
65	16.09	11.57	17.23	12.39	18.00	12.94	19.04	13.69
75	15.83	11.53	16.66	12.13	17.59	12.81	18.51	13.48
85	15.29	11.29	16.10	11.89	16.99	12.56	17.98	13.29
95	14.75	11.65	15.80	12.48	16.58	13.10	17.45	13.79
105	14.00	11.34	14.74	11.94	15.48	12.53	16.38	13.26
110	13.00	10.79	13.84	11.49	14.53	12.06	15.30	12.70
115	11.76	10.59	12.53	11.27	13.09	11.78	13.92	12.53
122	10.59	9.85	11.09	10.31	11.71	10.89	12.39	11.52

COOLING CAPACITY - 024 (208/230V)

Outdoor Temperature - °F (Dry Bulb)	Indoor Temperature - °F (Dry Bulb / Wet Bulb)							
	65°F / 54°F		70°F / 59°F		75°F / 63°F		80°F / 67°F	
	Total mBtuh	Sensible mBtuh	Total mBtuh	Sensible mBtuh	Total mBtuh	Sensible mBtuh	Total mBtuh	Sensible mBtuh
5	17.92	14.25	19.22	15.28	20.19	16.03	21.59	17.03
15	17.95	14.49	19.47	15.72	20.34	16.34	21.75	17.41
25	18.32	14.28	19.31	15.05	20.41	15.85	21.94	16.79
35	18.39	14.32	19.61	15.27	20.72	16.14	22.16	16.99
45	18.47	13.93	19.93	15.03	20.94	15.79	22.39	16.89
55	18.87	13.69	20.22	14.67	21.02	15.25	22.60	16.40
65	18.93	13.65	20.30	14.63	21.33	15.38	22.81	16.44
75	18.99	15.11	20.60	16.39	21.53	17.12	23.02	18.31
85	19.41	15.67	20.46	16.51	21.62	17.45	23.25	18.76
95	19.47	15.17	20.76	16.17	21.93	17.09	23.46	18.28
105	17.81	13.86	19.21	14.96	20.18	15.71	21.59	16.81
110	16.47	13.40	17.65	14.37	18.44	14.93	19.72	15.83
115	14.89	13.73	15.97	14.73	16.69	15.19	17.94	16.27
122	13.17	12.63	14.29	13.70	14.93	14.31	15.97	15.31

AIR THROW DATA

MWCA009S4 - COOLING

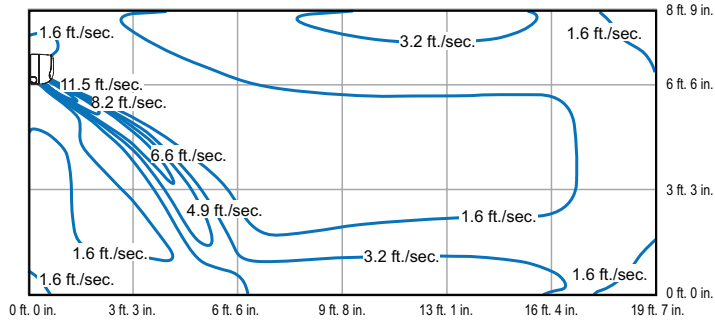

MWCA012S4 - COOLING

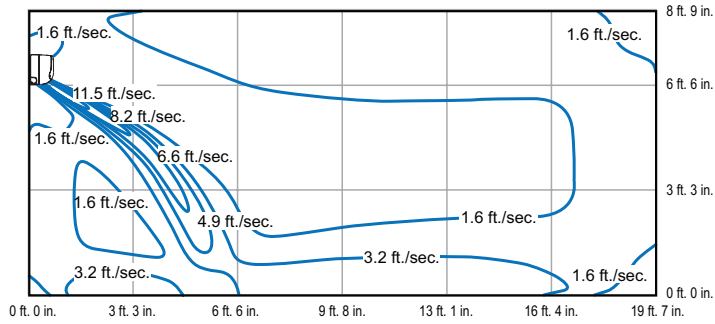

MWCA018S4 - COOLING

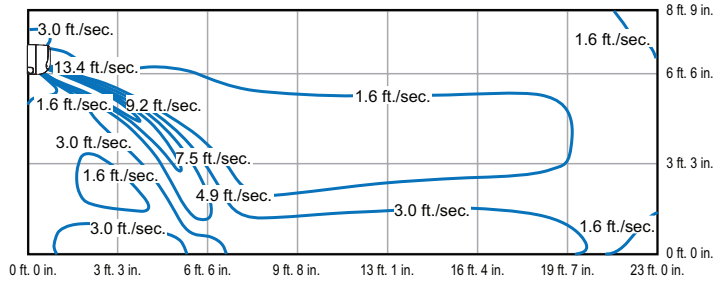

MWCA024S4 - COOLING

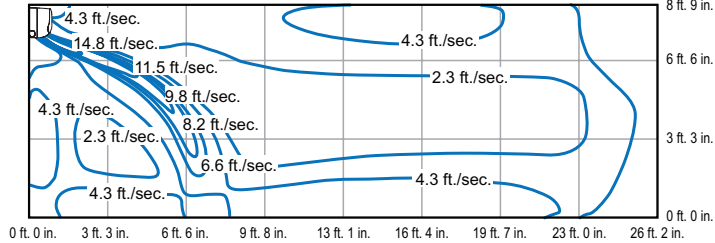

DIMENSIONS - OUTDOOR UNITS

MCA009S4S, MCA012S4S, MCA018S4S

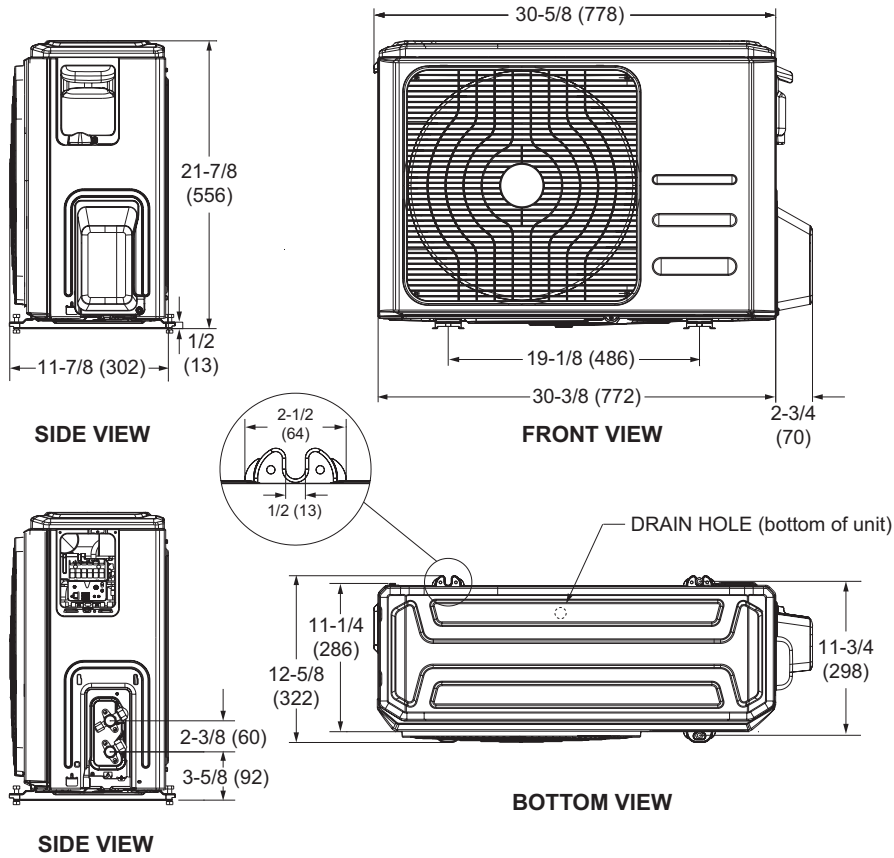

MCA024S4S

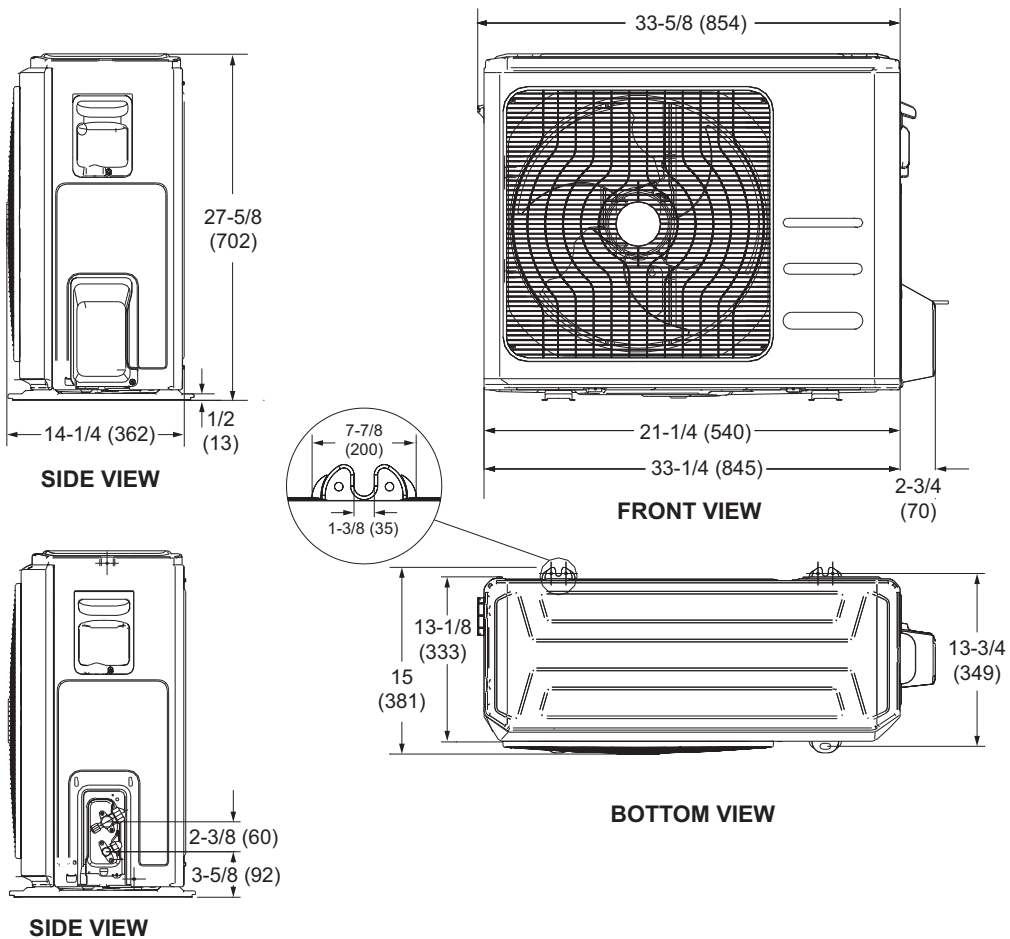

DIMENSIONS - WALL-MOUNTED INDOOR UNITS

MWCA009S4, MWCA009S4, MWCA012S4, MWCA012S4, MWCA018S4, MWCA024S4, MWCA030S4

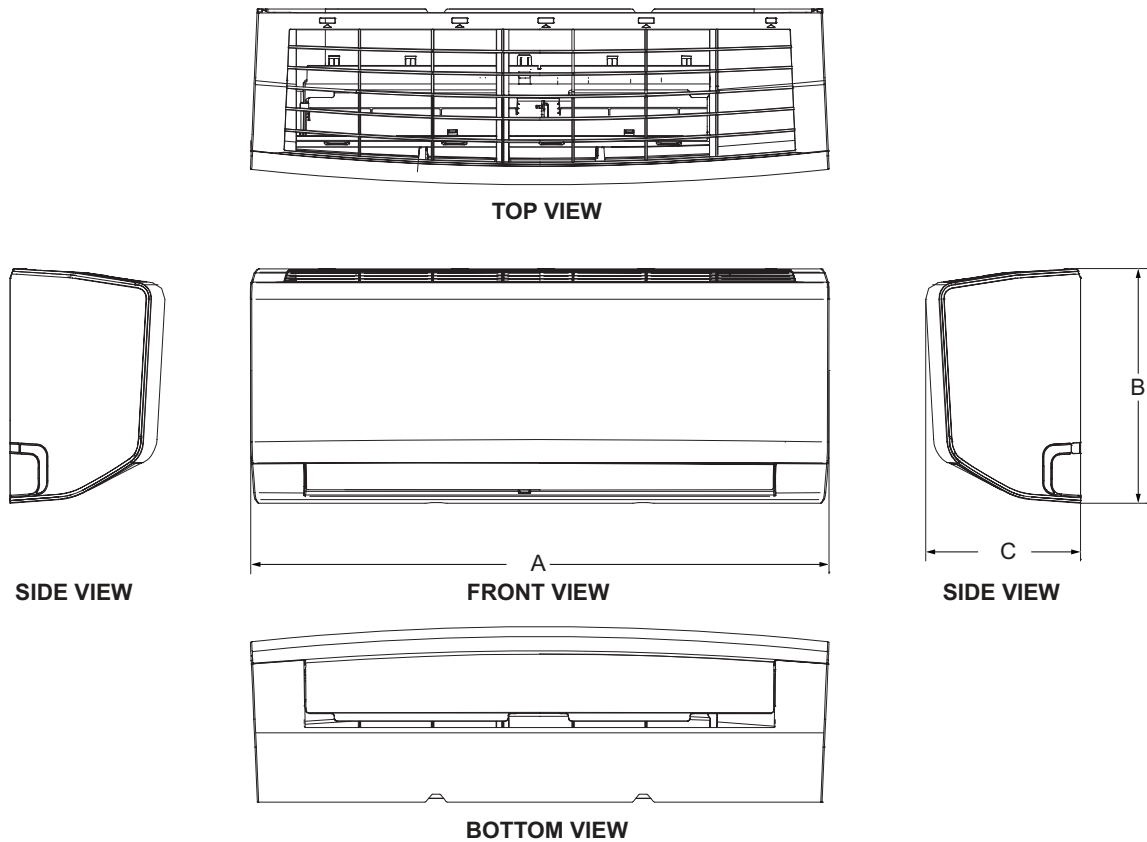

Size	A		B		C	
	in.	mm	in.	mm	in.	mm
MWCA009	29-5/8	752	11-3/8	289	8-5/8	219
MWCA012	32-3/4	832	11-3/4	298	8-3/4	222
MWCA018	39-1/8	994	12-1/2	318	9-7/8	251
MWCA024	44	1118	13-1/4	337	10-1/4	260

DIMENSIONS - WALL-MOUNTED INDOOR UNITS - WALL PLATES

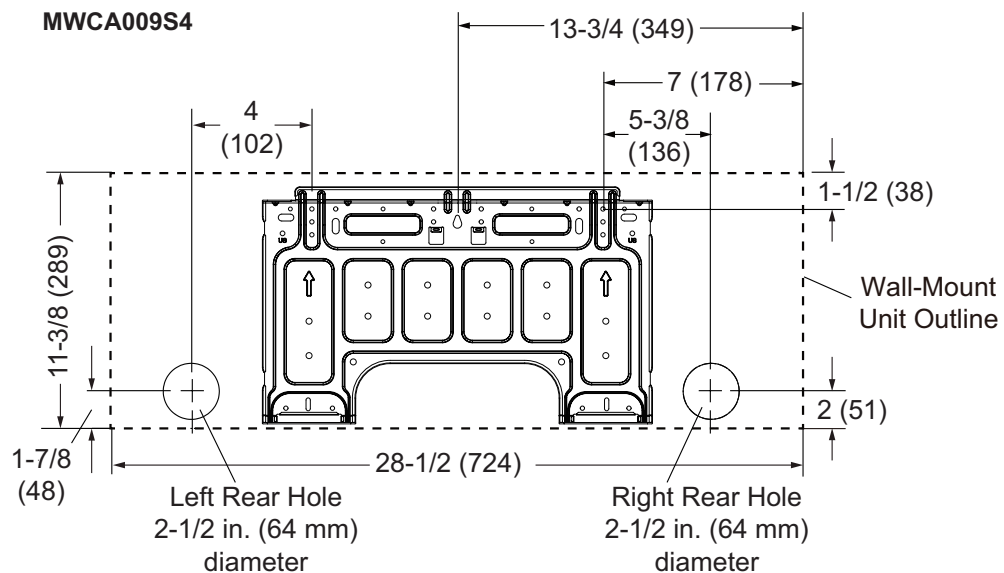

DIMENSIONS - WALL-MOUNTED INDOOR UNITS - WALL PLATES

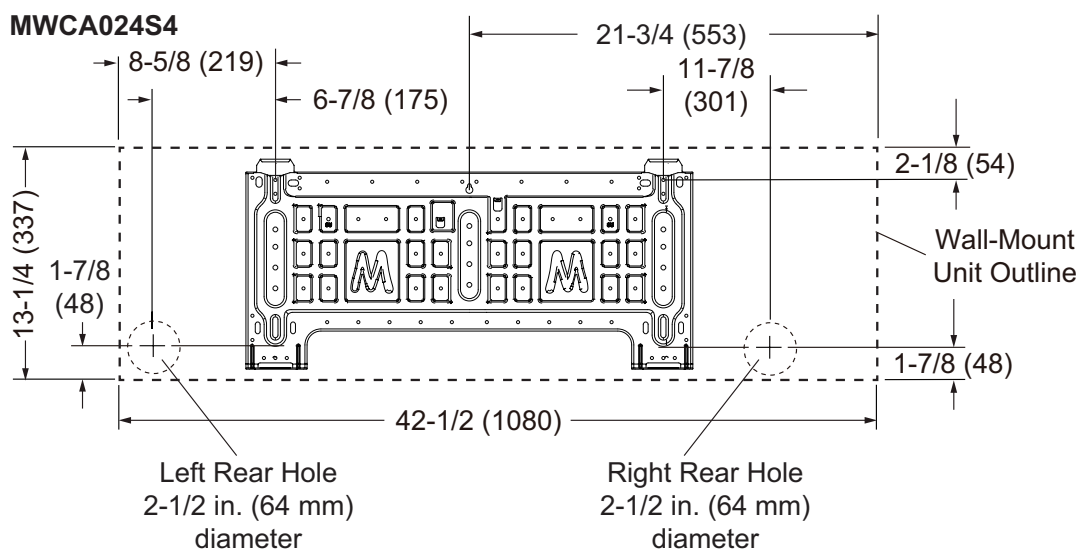
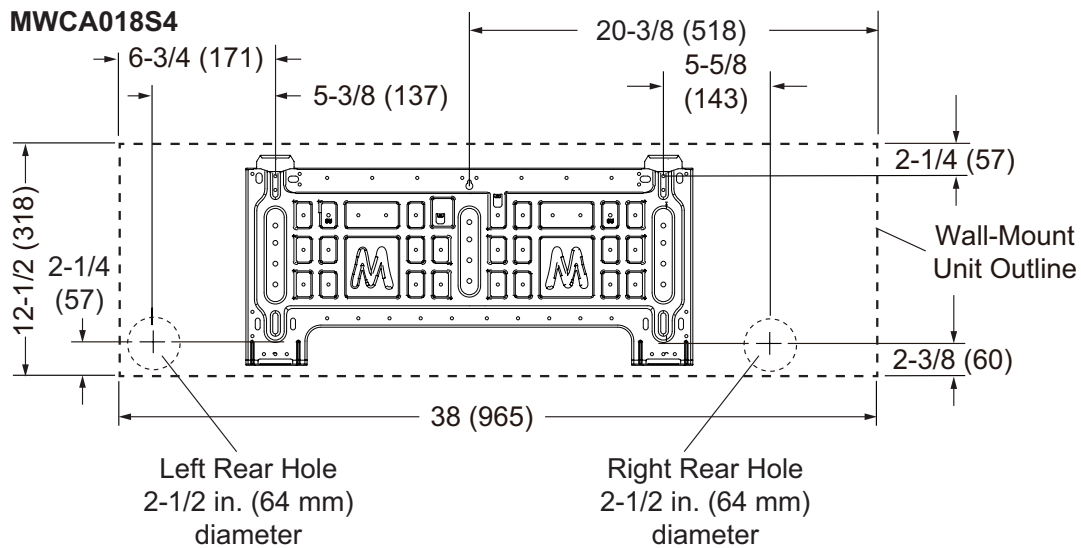
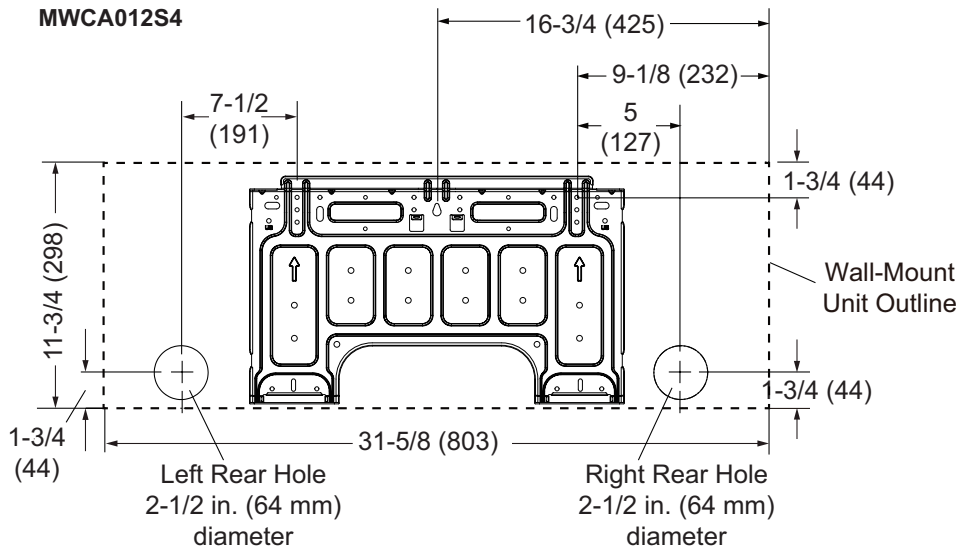

INSTALLATION CLEARANCES - OUTDOOR UNITS

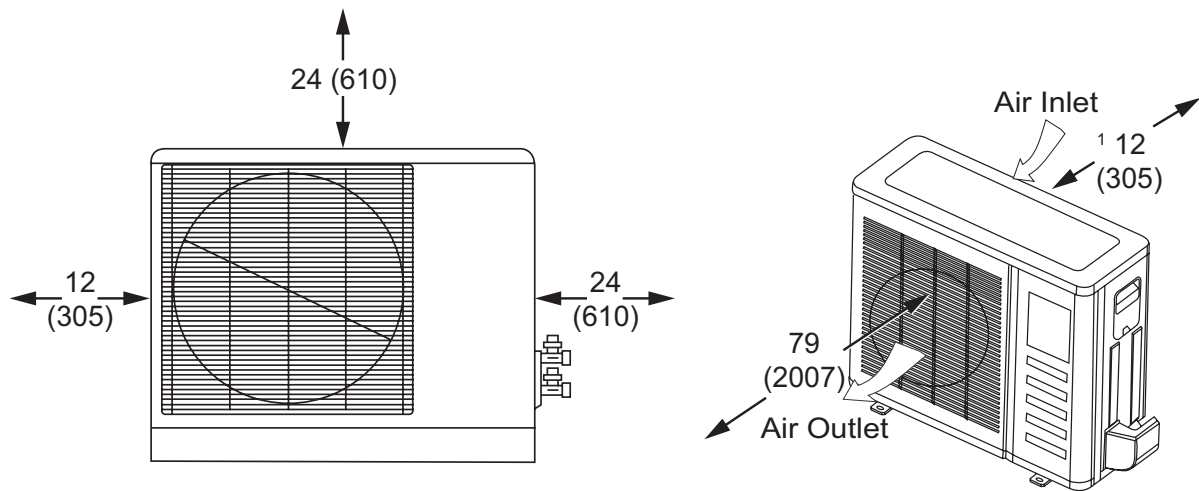

¹ Minimum rear clearance can be 6 inches (152 mm) when mounted on brackets and with no obstructions on the other three sides.

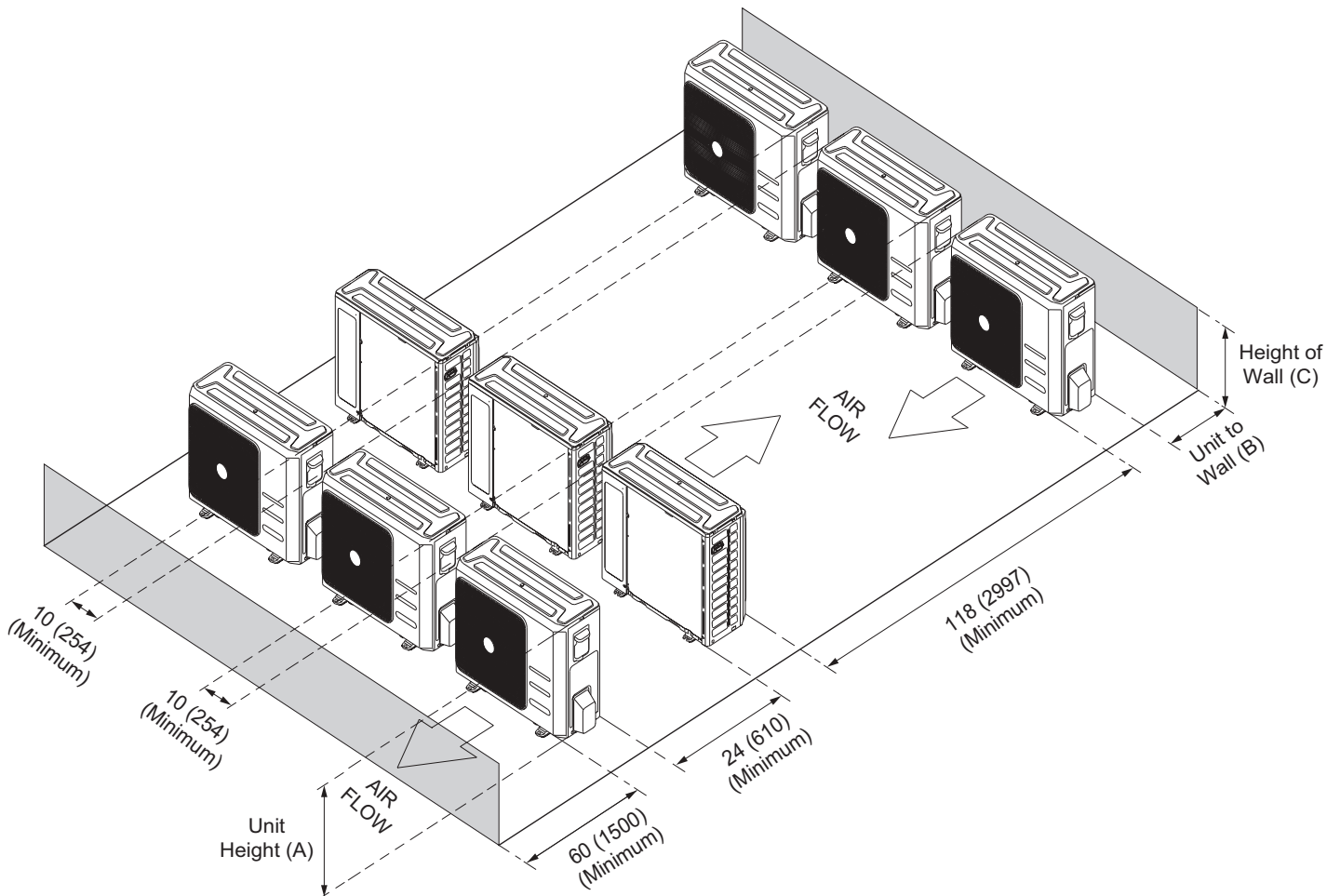

CLEARANCE NOTES FOR MULTIPLE UNITS:

If the height of the wall (C) is less than or equal to the height of the smallest unit (A), the distance from the unit to the wall (B) must be a minimum of 10 inches (254 mm).

If 1/2 the height of the unit (A) is less than the height of the wall (C), the distance from the unit to the wall (B) must be a minimum of 12 inches (305 mm).

If the height of the wall (C) is greater than the height of the unit (A), the distance from the unit to the wall (B) must be a minimum of 20 inches (508 mm).

INSTALLATION CLEARANCES - WALL-MOUNTED INDOOR UNITS

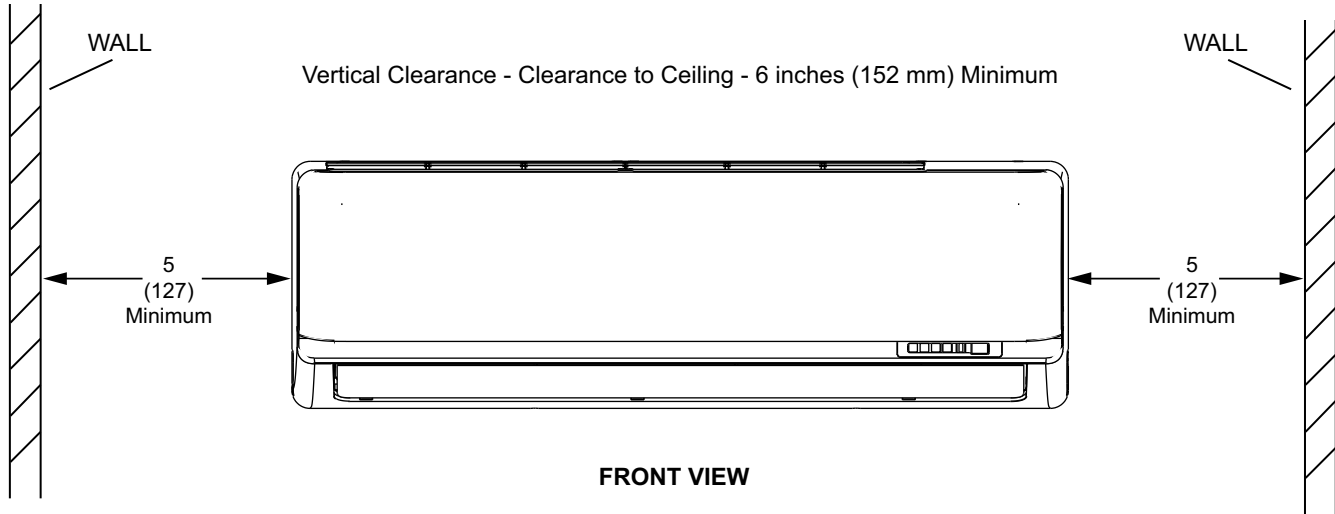

Vertical Clearance - Clearance to Floor - 72 inches (1829 mm) Minimum
 NOTE - Provide 96 inches (2438) clearance to floor for best performance

LINE SET AND ELEVATION GUIDELINES

Outdoor Unit BELOW Indoor Unit

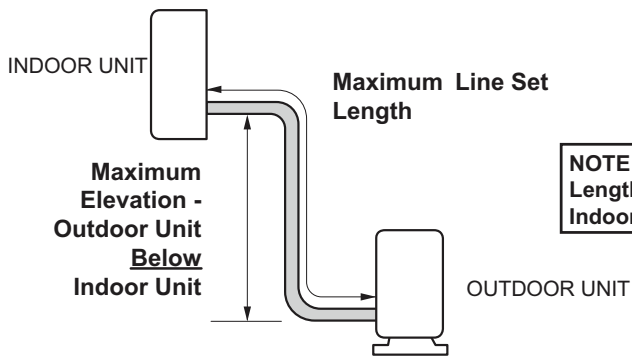

Outdoor Unit ABOVE Indoor Unit

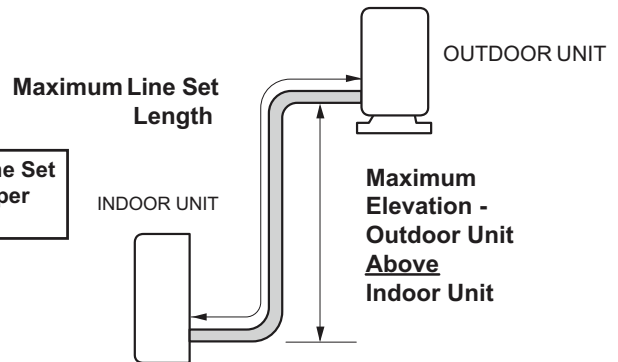

Size	Line Set Diameters (in.)		Maximum Elevation - Outdoor Unit <u>Below</u> Indoor Unit ft. (m)	Maximum Elevation - Outdoor Unit <u>Above</u> Indoor Unit ft. (m)	Maximum Line Set Length ft. (m)
	Liquid	Gas			
009	1/4	3/8	33 ft. (10 m)	33 ft. (10 m)	82 ft. (25 m)
012	1/4	1/2	33 ft. (10 m)	33 ft. (10 m)	82 ft. (25 m)
018	1/4	1/2	66 ft. (20 m)	66 ft. (20 m)	98 ft. (30 m)
024	3/8	5/8	66 ft. (20 m)	66 ft. (20 m)	98 ft. (30 m)

REVISIONS

Sections	Description of Change
Specifications	Maximum line length with furnished charge - ft. updated.



Visit us at www.lennox.com

For the latest technical information, www.LennoxPros.com

Contact us at 1-800-4-LENNOX

NOTE - Due to Lennox' ongoing commitment to quality, Specifications, Ratings and Dimensions subject to change without notice and without incurring liability. Improper installation, adjustment, alteration, service or maintenance can cause property damage or personal injury. Installation and service must be performed by a qualified installer and servicing agency.

©2020 Lennox Industries, Inc.