



**COMMERCIAL  
PRODUCT SPECIFICATIONS**

Bulletin No. 210905  
July 2020  
Supersedes June 2020



**MERIT®  
SERIES**



**SEER up to 16.00**

**HSPF up to 9.00**

**3 to 5 Tons**

**Cooling Capacity - 32,400 to 58,500 Btuh**

**Heating Capacity - 30,000 to 58,500 Btuh**

**MODEL NUMBER IDENTIFICATION**

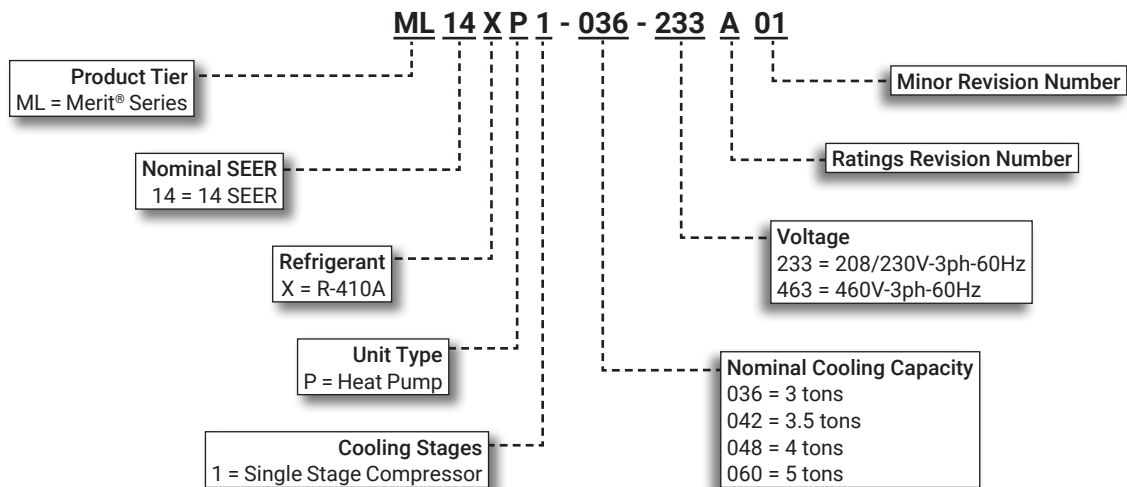

## FEATURE HIGHLIGHTS

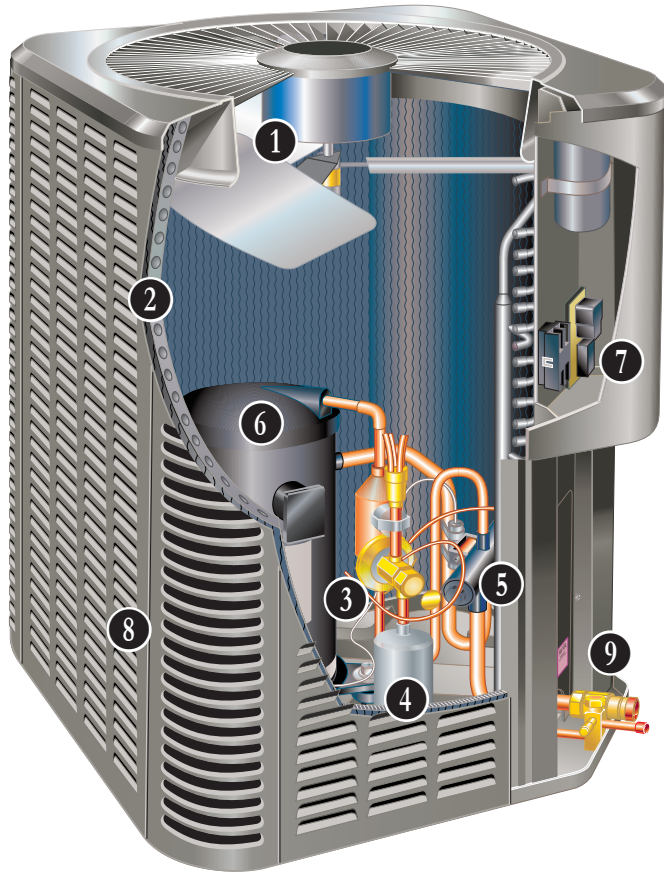

1. Outdoor Coil Fan
2. Quantum™ Coil
3. Expansion Valve - Outdoor Unit
4. High Capacity Liquid Line Drier
5. Four-Way Reversing Valve
6. Scroll Compressor
7. Defrost Control
8. Heavy Gauge Steel Cabinet
9. Refrigerant Line Access

## CONTENTS

Approvals And Warranty . . . . .	3
Dimensions . . . . .	8
Electrical Data . . . . .	6
Features . . . . .	3
Installation Clearances . . . . .	7
Model Number Identification . . . . .	1
Optional Accessories - Order Separately . . . . .	6
Optional Conventional Temperature Control Systems . . . . .	9
Sound Data . . . . .	7
Specifications . . . . .	6

## APPROVALS AND WARRANTY

### APPROVALS

- AHRI Standard 210/240 certified
- AHRI Certified system match-ups and expanded ratings, visit [www.LennoxPros.com](http://www.LennoxPros.com)
- Sound rated to AHRI Standard 270-2008 test conditions
- Tested in Lennox' Research Laboratory environmental test room environmental test room
- Rated According to U.S. Department of Energy (DOE) test procedures
- Unit and components ETL, NEC and CEC bonded for grounding to meet safety standards for servicing
- ETL certified (U.S. and Canada)
- ISO 9001 Registered Manufacturing Quality System

### WARRANTY

- Compressor - Limited five years
- All other covered components - Limited one year

**NOTE** - Refer to Equipment Limited Warranty certificate included with unit for specific details.

## FEATURES

### APPLICATIONS

- 3 through 5 tons
- 208/230V or 460V-3ph models
- Sound levels low as 79 dBA
- Vertical air discharge
- Applicable to indoor air handlers or gas furnaces with indoor add-on coils
- Shipped completely factory assembled, piped and wired

**NOTE** - When heat pumps are used with gas furnaces, a dual-fuel compatible thermostat or zone control system with dual-fuel capabilities must be used (order separately).

**NOTE** - Installer must set outdoor unit, connect refrigerant lines and make electrical connections to complete job.

### REFRIGERATION SYSTEM

#### R-410A Refrigerant

- Non-chlorine, ozone friendly
- Unit is factory pre-charged

**NOTE** - Total system refrigerant charge is dependant on outdoor unit size, indoor unit size and refrigerant line length.

**NOTE** - Refer to Installation Instructions for "Indoor Unit Match-Up and Sub-Cooling Charge Levels" to determine correct amount of charge required.

#### 1 Outdoor Coil Fan

- Direct drive fan
- Vertical air discharge
- Louvered steel top fan guard
- Totally enclosed fan motor
- Ball bearings
- Inherently protected

#### 2 Quantum™ Coil

- Lennox designed and fabricated coil
- Enhanced aluminum alloy tube/enhanced fin coil
- Superior corrosion resistance
- Ripple-edged aluminum fins
- Aluminum tube construction
- Lanced fins for maximum fin surface exposure
- Fin collars grip tubing for maximum contact area
- Flared shoulder tubing connections
- Factory tested under high pressure
- Entire coil is accessible for cleaning

#### 3 Expansion Valve - Outdoor Unit

- Designed and sized for heat pump systems
- Sensing bulb senses evaporator suction temperature during heating cycle

#### High Pressure Switch

- Protects the system from high pressure conditions
- Automatic reset

#### Low Pressure Switch

- Shuts off unit if suction pressure falls below setting
- Loss of charge and freeze-up protection
- Automatic reset

#### 4 High Capacity Liquid Line Drier

- Factory installed in the liquid line
- Drier traps moisture or dirt
- 100% molecular-sieve, bead type, bi-flow drier

#### 5 Four-Way Reversing Valve

- Rapid changeover of refrigerant flow direction from cooling to heating and vice versa
- Operates on pressure differential between outdoor unit and indoor coil
- Factory installed

## FEATURES

### REFRIGERATION SYSTEM (continued)

#### Optional Accessories

##### Check/Expansion Valve Kits

- Field installed on certain indoor units
- See TXV Usage table
- Chatleff-style fitting

##### Freezestat

- Senses suction line temperature
- Cycles compressor off when suction line temperature falls below it's setpoint
- Opens at 29°F and closes at 58°F
- Installs on or near the discharge line of the evaporator or on the suction line

##### Refrigerant Line Kits

- Refrigerant lines are shipped refrigeration clean
- Lines are cleaned, dried, pressurized and sealed at factory
- Suction line fully insulated
- Lines are stubbed at both ends

**NOTE** - Not available for 060 models. Must be field fabricated.

### COMPRESSOR

#### 6 Scroll Compressor

- High efficiency with uniform suction flow
- Constant discharge flow, high volumetric efficiency and quiet operation
- Low gas pulses during compression reduces operational sound levels
- Compressor motor is internally protected from excessive current and temperature
- Muffler in discharge line reduces operating sound levels
- Compressor is installed in the unit on resilient rubber mounts for vibration free operation

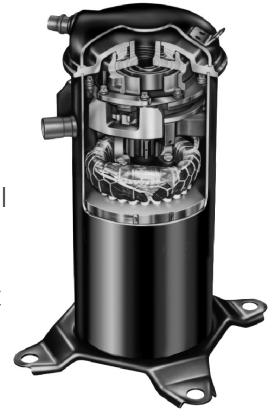

#### Scroll Compressor Operation

- Two involute spiral scrolls matched together generate a series of crescent-shaped gas pockets between them
- During compression, one scroll remains stationary while the other scroll orbits around it
- Gas is drawn into the outer pocket, the pocket is sealed as the scroll rotates
- As the spiral movement continues, gas pockets are pushed to the center of the scrolls. Volume between the pockets is simultaneously reduced
- When the pocket reaches the center, gas is now at high pressure and is forced out of a port located in the center of the fixed scrolls
- During compression, several pockets are compressed simultaneously resulting in a smooth continuous compression cycle
- Continuous flank contact, maintained by centrifugal force, minimizes gas leakage and maximizes efficiency
- Compressor is tolerant to the effects of slugging and contaminants. If this occurs, scrolls separate, allowing liquid or contaminants to be worked toward the center and discharged

#### Compressor Crankcase Heater

- Protects against refrigerant migration that can occur during low ambient operation

#### Optional Accessories

##### Compressor Sound Cover

- Reinforced vinyl compressor cover
- 1-1/2 inch thick batt of fiberglass insulation
- Hook and loop fastening tape on all open edges

## FEATURES

### **CONTROLS**

- 7 Defrost Control**
- Time/temperature defrost control
  - Defrost cycle every 30, 60 or 90 minutes of compressor "on" time at outdoor coil temperatures below 42°F
  - Factory setting - 90 minutes
  - Anti-short cycle, timed-off control - 5 minutes
  - Compressor delay - 30 seconds (field selectable) cycles the compressor in and out of defrost mode
  - High and low pressure switch monitoring (five-trip lockout)
  - Two diagnostic LEDs furnished for troubleshooting
  - Conveniently located in control box

### **Optional Accessories**

#### **Compressor Low Ambient Cut-Off**

- Non-adjustable switch (low ambient cut-out)
- Prevents compressor operation in cooling mode when outdoor temperature is below 35°F

#### **Indoor Blower Off Delay Relay Kit**

- Delays indoor blower-off time during the cooling cycle

#### **Low Ambient Kit**

- Heat pump can operate in the cooling mode down to 45°F outdoor air temperature without additional controls
- Two low ambient control options are available for field installation:
  1. Low Ambient Control Kit (30°F)
  2. Low Ambient Control (0°F)  
Requires Speed Control and Weatherproof Kit (ordered separately). Available for 208/230V models only.

**NOTE** - Freezestat should be installed on compressors equipped with a low ambient kit.

#### **Mild Weather Kit**

- Units can operate in the heating mode at outdoor air temperatures up to 75°F
- Field installed kit allows heating operation above 75°F

#### **Monitor Kit - Service Light**

- Ambient compensating thermistor
- Service light thermostat
- For thermostats requiring indicator light inputs

#### **Outdoor Thermostat Kit**

- Outdoor thermostat locks out some of the electric heating elements on indoor units where two-stage control is applicable
- Outdoor thermostat maintains the heating load on low power input as long as possible before allowing the full power load to come on the line
- Thermostat Kit and Mounting Box must be ordered separately

#### **Thermostats**

- For thermostat options, see Optional Conventional Temperature Control Systems on Page 9

### **8 CABINET**

- Heavy gauge steel cabinet
- Five station metal wash process
- Louvered heavy gauge steel panels
- Powder paint finish for superior rust and corrosion protection
- Control box conveniently located with all controls factory wired
- Corner patch plate allows compressor access
- Drainage holes provided in base section

#### **PermaGuard™ Unit Base**

- Durable zinc-coated base section resists rust and corrosion

### **9 Refrigerant Line Connections, Electrical Inlets, Service Valves**

- Sweat connection vapor and liquid lines
- Located on corner of unit cabinet
- Fully serviceable brass service valves
- Vapor valve can be fully shut off, while liquid valve may be front seated to manage refrigerant charge while servicing system
- Refrigerant line connections and field wiring inlets are located in one central area of cabinet for easy access
- See dimension drawing

### **Optional Accessories**

#### **Unit Stand-Off Kit**

- Black high density polyethylene feet
- Raises unit off mounting surface
- Four feet furnished per order number

#### **Snow Guard**

- For locations where heavy snow or freezing rain accumulation may occur
- Heavy gauge powder coated steel guard
- Deflects snow and ice away from the outdoor fan and prevents build-up on the fan guard

## SPECIFICATIONS

General Data	Model No. - 208/230V-3ph	ML14XP1-036-233	ML14XP1-042-233	ML14XP1-048-233	ML14XP1-060-233
	Model No. - 460V-3ph	ML14XP1-036-463	ML14XP1-042-463	ML14XP1-048-463	ML14XP1-060-463
	Nominal Tonnage	3	3.5	4	5
<sup>1</sup> Sound Rating Number		76	79	80	80
Connections (sweat)	Liquid line o.d. - in.	3/8	3/8	3/8	3/8
	Vapor line o.d. - in.	7/8	7/8	7/8	1-1/8
<sup>2</sup> Refrigerant	R-410A charge furnished	8 lbs. 10 oz.	11 lbs. 14 oz.	10 lbs. 7 oz.	12 lbs. 11 oz.
Outdoor Coil	Net face area - sq. ft. Outer coil	21.0	24.93	24.93	29.09
	Inner coil	20.3	24.13	24.13	28.16
	Tube diameter - in.	5/16	5/16	5/16	5/16
	No. of rows	2	2	2	2
	Fins per inch	22	22	22	22
Outdoor Fan	Diameter - in.	22	26	26	26
	No. of Blades	3	4	4	4
	Motor hp	1/6	1/3	1/3	1/3
	Cfm	2870	4347	4347	4500
	Rpm	839	843	843	830
	Watts	205	299	299	307
	Shipping Data - lbs. 1 package		229	272	273

## ELECTRICAL DATA

Line voltage data - 60 Hz - 3ph		208/230V	460V	208/230V	460V	208/230V	460V	208/230V	460V
<sup>3</sup> Maximum overcurrent protection (amps)		20	N/A	30	10	30	10	30	10
<sup>4</sup> Minimum circuit ampacity		12.2		18.3	8.2	18.5	8.5	18.3	8.6
Compressor	Rated Load Amps	9.0		13.5	6.0	13.7	6.2	13.2	6.3
	Locked Rotor Amps	71		88	44	83.1	41	93	55
	Power Factor	0.80		0.84	0.84	0.91	0.91	0.97	0.97
Outdoor Fan Motor	Full Load Amps	1.0		1.8	0.7	1.8	0.7	1.8	0.7
	Locked Rotor Amps	1.9		2.9	2.5	2.9	2.5	2.9	2.5

## OPTIONAL ACCESSORIES - ORDER SEPARATELY

Compressor Low Ambient Cut-Off	45F08	•	•	•	•
Compressor Sound Cover	18J42	•	•	•	•
Freezestat	3/8 in. tubing	93G35	•	•	•
	5/8 in. tubing	50A93	•	•	•
Indoor Blower Off Delay Relay	58M81	•	•	•	•
<sup>5</sup> Low Ambient Kit (30°F)	54M89	•	•	•	•
<sup>5</sup> Low Ambient Control (0°F)	Speed Control	X5867	•	•	•
	Weatherproof Kit	56N41	•	•	•
Mild Weather Kit	11B97	•	•	•	•
Monitor Kit - Service Light	76F53	•	•	•	•
Outdoor Thermostat Kit	Thermostat	10Z23	•	•	•
	Mounting Box	31461	•	•	•
Refrigerant Line Sets	L15-65-30, L15-65-40, L15-65-50	•	•	•	•
	Field Fabricate				•
Snow Guard	94M98	•	•	•	•
Unit Stand-Off Kit	94J45	•	•	•	•

NOTE - Extremes of operating range are plus 10% and minus 5% of line voltage.

<sup>1</sup> Sound Rating Number rated in accordance with test conditions included in AHRI Standard 270.

<sup>2</sup> Refrigerant charge sufficient for 15 ft. length of refrigerant lines. For longer line set requirements see the Installation Instructions for information about line set length and additional refrigerant charge required.

<sup>3</sup> HACR type circuit breaker or fuse.

<sup>4</sup> Refer to National or Canadian Electrical Code manual to determine wire, fuse and disconnect size requirements.

<sup>5</sup> Freezestat are recommended with Low Ambient Kit.

## SOUND DATA

<sup>1</sup> Unit Model	Octave Band Sound Power Levels dBA, re 10 <sup>-12</sup> Watts Center Frequency - HZ							<sup>1</sup> Sound Rating Number (dBA)	<sup>2</sup> Estimated Sound Pressure Level at Distance From Unit (dBA at distance in ft.)				
	125	250	500	1000	2000	4000	8000		3	5	10	15	50
036	55.5	66	70.5	70.5	66.5	61.5	56	76	69	64	58	55	44
042	63	70.5	74.5	73	70	64	56	79	72	67	61	58	47
048	64	72.5	75.5	73	69.5	63.5	56	80	73	68	62	59	48
060	61.5	69	73.5	73.5	70.5	67	62	80	73	68	62	59	48

NOTE - the octave sound power data does not include tonal correction.

<sup>1</sup> Tested according to AHRI Standard 270-2008 test conditions.

<sup>2</sup> Estimated sound pressure level at distance based on AHRI Standard 275-2010 method for equipment located on the ground, roof, or on side of building wall with no adjacent reflective surface within 9.8 feet. Sound pressure levels will increase based on changes to assumptions. For other applications, refer to AHRI Standard 275.

## INSTALLATION CLEARANCES

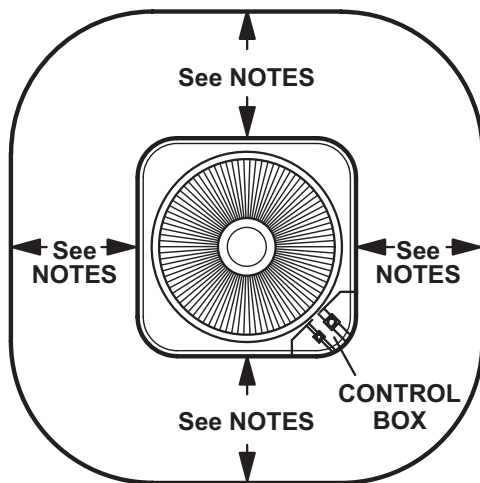

### NOTES:

Service clearance of 30 in. (762 mm) must be maintained on one of the sides adjacent to the control box.

Clearance to one of the other three sides must be 36 in. (914 mm)

Clearance to one of the remaining two sides may be 12 in. (305 mm) and the final side may be 6 in. (152 mm).

A clearance of 24 in. must be maintained between two units. 48 in. (1219 mm) clearance required on top of unit.

# DIMENSIONS

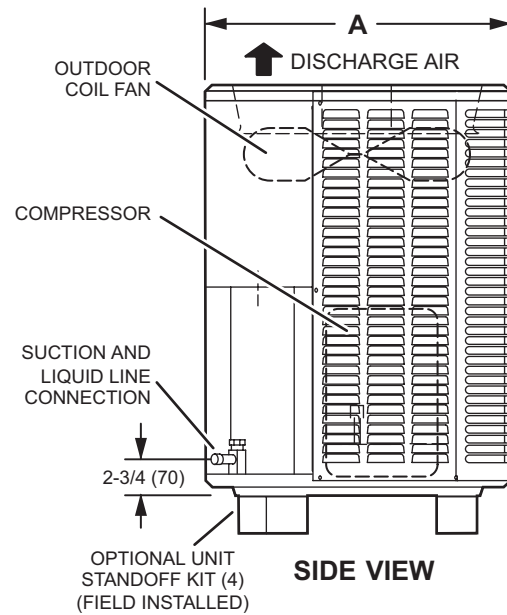
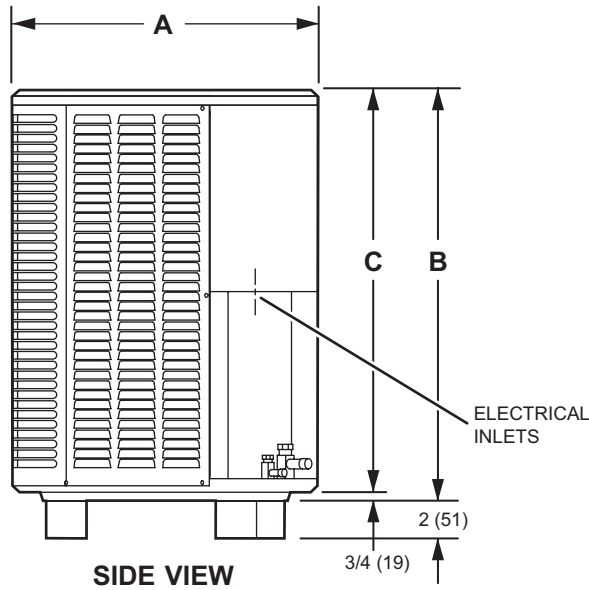
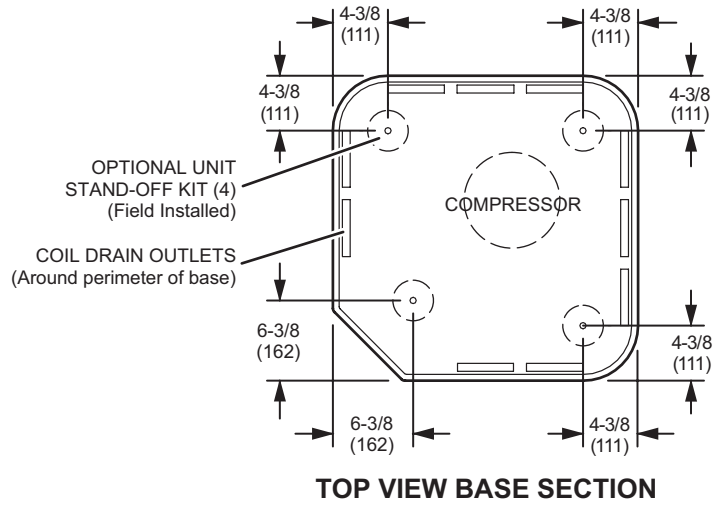
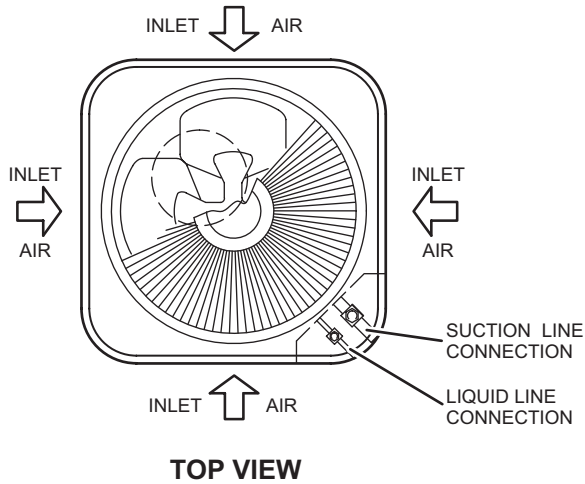

Model No.	A		B		C	
	inches	mm	inches	mm	inches	mm
ML14XP1-036	28-1/4	718	37-1/4	946	36-1/2	927
ML14XP1-042	32-1/4	819	37-1/4	946	36-1/2	927
ML14XP1-048	32-1/4	819	37-1/4	946	36-1/2	927
ML14XP1-060	32-1/4	819	43-1/4	1099	42-1/2	1080



## OPTIONAL CONVENTIONAL TEMPERATURE CONTROL SYSTEMS

### Comfordsense® 7500 Commercial 7-Day Programmable Thermostat



- Four-Stage Heating / Two-Stage Cooling
- Universal Multi-Stage
- Intuitive Touchscreen Interface
- Automatic Changeover between Heating and Cooling
- Full Seven-Day Programming
- Four Time Periods Per Day
- Temperature and Humidity Control
- One-Touch Away Mode
- Holiday Scheduling
- Smooth Setback Recovery (SSR)
- Performance Reports
- Notifications/Reminders
- Dehumidification/Humiditrol® Control for Split Systems and Rooftop Units
- Economizer Relay Control
- Backlit Display
- Wallplate Furnished
- FDD, ASHRAE and IECC Compliant

### Comfordsense® 3000 Commercial 5-2 Day Programmable Thermostat



- Two-Stage Heating / Two-Stage Cooling
- Conventional Systems
- Intuitive Interface
- 5-2 Day Programming
- Program Hold
- Remote Indoor Temperature Sensing
- Smooth Setback Recovery (SSR)
- Economizer Relay Control
- Maintenance/Filter/Service Reminders
- Backlit Display
- Wallplate Furnished
- Simple Up and Down Temperature Control

### Comfordsense® Non-Programmable Thermostat

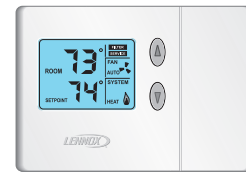

- One-Stage Heating / Cooling
- Conventional Systems
- Intuitive Interface
- Manual Changeover
- Backlit Display
- Simple Up and Down Temperature Control

## OPTIONAL CONVENTIONAL TEMPERATURE CONTROL SYSTEMS

Description	Model No.	Catalog No.
<b>Comfordsense® 7500 Commercial 7-Day Programmable Thermostat</b>	C0STAT06FF2L	<b>17G74</b>
Universal thermostat locking guard (clear)	C0MISC15AE1-	<b>39P21</b>
<b>Temperature Sensors</b>	<sup>1</sup> Remote non-adjustable wall-mount 20k	C0SNZN01AE2-
	<sup>1</sup> Remote non-adjustable wall-mount 10k	C0SNZN73AE1-
	Remote non-adjustable discharge air (duct mount)	C0SND00AE1-
	Outdoor temperature sensor	C0SNSR03AE1-
		<b>19L22</b>
		<b>X2658</b>
<sup>1</sup> Remote wall-mount sensors can be applied in any of the following combinations: One Sensor - (1) 47W36 Two Sensors - (2) 47W37 Three Sensors - (2) 47W36 and (1) 47W37 Four Sensors - (4) 47W36 Five Sensors - (3) 47W36 and (2) 47W37		
<b>Comfordsense® 3000 Commercial 5-2 Day Programmable Thermostat</b>	C0STAT05FF1L	<b>11Y05</b>
Thermostat wall mounting plate	C0MISC17AE1-	<b>X2659</b>
<b>Temperature Sensor</b>	Remote non-adjustable wall mount 10k averaging	C0SNZN73AE1-
		<b>47W37</b>
<b>Comfordsense® Non-Programmable Thermostat</b>	C0STAT12AE1L	<b>51M32</b>

## TXV USAGE

Use this table for C35, CH23, CH35 and CR33 Field Installed TXV Match-Ups

Model No.	Order No.
ML14XP1-036	<b>12J19</b>
ML14XP1-042	<b>12J20</b>
ML14XP1-048	<b>12J20</b>
ML14XP1-060	<b>12J20</b>

CX35 and CHX35 coils and all Lennox air handlers are shipped with a factory installed TXV.

C35 and CH35 coils - Replace the factory installed RFC orifice with the expansion valve listed.

CH23 and CR33 - Use the expansion valve listed.

## AHRI STANDARD 210/240

Cooling or heating capacities are net values, including the effects of blower motor heat, and do not include supplementary heat. Power input is the total power input to the compressor(s) and fan(s), plus any controls and other items required as part of the system for normal operation.

Units which do not have an indoor air-circulating blower furnished as part of the model, i.e., split system with indoor coil only, is established by subtracting from the total cooling capacity 1250 Btu/h per 1,000 cfm, and by adding the same amount to the heating capacity. Total power input for both heating and cooling is increased by 365 W per 1,000 cfm of indoor air circulated.



## REVISIONS

Sections	Description of Change
Specifications, Electrical	Added new 460V-3ph models.



Visit us at [www.lennox.com](http://www.lennox.com)

For the latest technical information, [www.lennoxcommercial.com](http://www.lennoxcommercial.com)

Contact us at 1-800-4-LENNOX

NOTE - Due to Lennox' ongoing commitment to quality, Specifications, Ratings and Dimensions subject to change without notice and without incurring liability. Improper installation, adjustment, alteration, service or maintenance can cause property damage or personal injury. Installation and service must be performed by a qualified installer and servicing agency.

©2020 Lennox Industries, Inc.