



**RESIDENTIAL  
PRODUCT SPECIFICATIONS**



**MERIT®  
SERIES**

**AFUE - 80%**  
**Input - 44,000 to 110,000 Btuh**  
**Nominal Add-on Cooling - 1.5 to 5 Tons**

**MODEL NUMBER IDENTIFICATION**

**ML 1 80 DF 070 E 36 B**

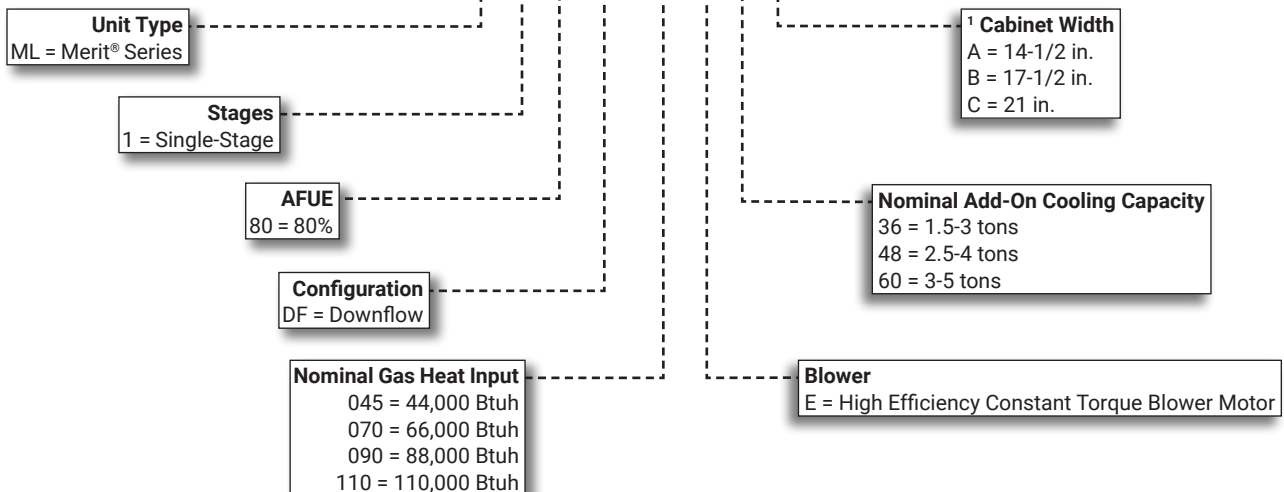

<sup>1</sup> Downflow indoor coils with the same letter designation physically match the furnace supply air opening.

## FEATURE HIGHLIGHTS

1. Lennox Duralok™ Heat Exchanger Assembly
2. Inshot Burners
3. SureLight® Hot Surface Ignitor
4. Gas Control Valve
5. Combustion Air Inducer
6. Flame Rollout Switches
7. Power Saver™ Constant Torque Blower
8. SureLight® Integrated Furnace Control
9. Insulated Cabinet
10. Safety Interlock Switch
11. Gas Piping And Electrical Inlets

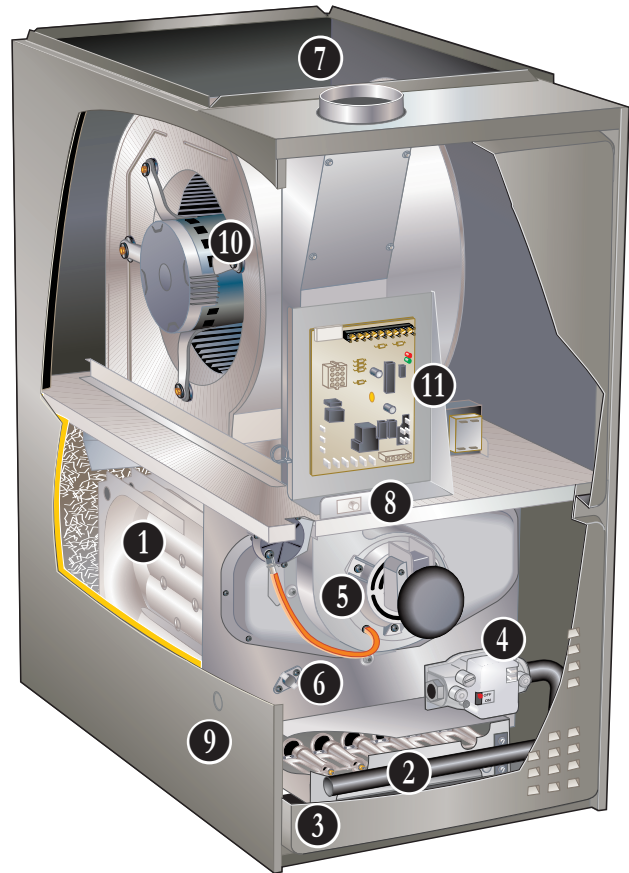

**NOTE - ML180E FURNACES ARE NOT AVAILABLE IN CANADA!**

## CONTENTS

Approvals and Warranty . . . . .	3
Blower Data . . . . .	11
Dimensions - Furnace/Coil Combined Dimensions . . . . .	10
Dimensions - Optional Accessories . . . . .	9
Dimensions - Unit . . . . .	8
Gas Heat Accessories . . . . .	6
High Altitude Derate . . . . .	7
Installation Clearances . . . . .	7
Optional Accessories - Order Separately . . . . .	6
Specifications . . . . .	6

## APPROVALS AND WARRANTY

### APPROVALS

- AHRI Certified
- Tested and rated according to US DOE test procedures and FTC labeling regulations
- "X" models approved by the California Energy Commission and meets California Nitrogen Oxides Standard (NOx) limits of 40 ng/J
- ISO 9001 Registered Manufacturing Quality System
- Blower data from unit tests conducted in Lennox Laboratory air test chamber

### **California Only**

- If installed in South Coast Air Quality Management District (SCAQMD) only
  - This furnace does not meet the SCAQMD Rule 1111 NOx emission limit (14 ng/J), and thus is subject to a mitigation fee of up to \$450. This furnace is not eligible for the Clean Air Furnace Rebate Program: [www.CleanAirFurnaceRebate.com](http://www.CleanAirFurnaceRebate.com)
- If installed in San Joaquin Valley Air Pollution Control District (SJVAPCD) only
  - This furnace does not meet the SJVAPCD Rule 4905 NOx emission limit (14 ng/J), and thus is subject to a mitigation fee of up to \$450

### WARRANTY

- Heat Exchanger:
  - Limited twenty years in residential applications
  - Limited ten years in non-residential applications
- All other covered components:
  - Limited five years in residential installations
  - Limited one year in non-residential installations

**NOTE** - Refer to Lennox Equipment Limited Warranty certificate included with unit for specific details.

## FEATURES

### APPLICATIONS

- Input capacities of 44,000, 66,000, 88,000 and 110,000 Btuh
- Energy efficiency (AFUE) - 80%
- Compact cabinet for downflow applications without any internal modifications to the unit
- Lennox add-on indoor coils, high-efficiency air cleaners and humidifiers can easily be added to furnace
- Shipped factory assembled with all controls installed and wired
- Each unit factory test operated to ensure proper operation

### HEATING SYSTEM

- 1 Lennox Duralok™ Heat Exchanger Assembly**
  - Heavy gauge aluminized steel heat exchanger
  - Crimped seam clamshell type design
  - Designed for normal expansion and contraction
  - Minimum resistance to air flow
  - Laboratory life cycle tested in excess of industry standards
  - Compact size permits low overall design of furnace cabinet

- 2 Inshot Burners**

- Aluminized steel inshot burners provide efficient, trouble-free operation
- Burner venturi mixes air and gas in correct proportion for proper combustion
- Burner assembly is removable from the unit as a single component for ease of service

- 3 SureLight® Hot Surface Ignitor**

- Tough, reliable, long-life, trouble-free performance
- Silicon nitride ignitor
- Cemented to steatite block for protection against current leakage
- Ignition leads are constructed of nickel plated copper and are enclosed in high temperature Teflon® insulation for dependable operation

- 4 Gas Control Valve**

- 24 volt redundant combination gas control valve combines manual shut off switch (On-Off), automatic electric valve (dual) and gas pressure regulation into a compact combination control

- 5 Combustion Air Inducer**

- Shaded pole heavy duty blower prepurges heat exchanger and safely vents flue products
- Pressure switch proves blower operation before allowing gas valve to open
- Operates only during heating cycle

## FEATURES

### HEATING SYSTEM (continued)

- 6 **Flame Rollout Switch**
  - Factory installed inside burner box
  - Switches provides protection from abnormal operating conditions
  - Manual reset

#### Limit Controls

- Primary limit factory installed on vestibule panel
- Secondary limit factory installed on blower housing
- Automatic reset

#### Optional Accessories

##### High Altitude Pressure Switch Kit

- Required on most units for proper unit operation at altitudes from 4,501 to 7500 ft.

##### Natural Gas to LPG/Propane Conversion Kit

- Required for field changeover from natural gas to LPG/Propane

##### LPG/Propane to Natural Gas Conversion Kit

- Required for field changeover from LPG/Propane to natural gas

### CABINET

- Low-profile, narrow width cabinet allows easy installation in downflow applications
- Heavy-gauge, cold rolled steel construction
- Pre-painted cabinet finish
- Flanges provided on supply air opening for ease of plenum connection or alignment with indoor coil
- 7 • Insulated with foil faced insulation on sides and back of heating compartment
- Complete service access
- 8 • Safety interlock switch automatically shuts off power to unit when blower compartment access panel is removed
- 9 • Gas piping and electrical inlets are provided in both sides of cabinet

#### Low Leakage Cabinet

- All models have less than 2% air leakage
- Meets ANSI/ASHRAE Standard 193-2010 "Method of Test for Determining the Air Tightness of HVAC Equipment"

#### Coil Match-up

- All Lennox downflow indoor coils will physically match the furnace supply air opening with the same letter designation (A, B, C, D) as in the furnace model number

#### Optional Accessories

##### Downflow Combustible Flooring Base

- Required for heating only units installed on combustible floors
- Not required in add-on cooling applications
- See Dimension Drawing

### FILTER

- Filter and provisions for external mounting must be field provided

#### Optional Accessories

##### Downflow Filter Cabinet

- Filter cabinet mounts directly on top of furnace
- "A" width cabinet includes one filter
- "B and "C" width cabinets have two filters
- Filter rails are furnished
- Front access for servicing
- Cleanable filter(s) are furnished

### BLOWER

#### 10 Power Saver™ Constant Torque Blower Motor

- Programmable high efficiency multi-speed blower motor. By maintaining constant torque output, blower motor can deliver more uniform (but not constant) airflow over the static pressure range
- Programmable multi-speed operation is achieved by the use of an ECM (Electronically Commutated Motor) motor
- Leadless blower motor features simple plug-in connections
- Controlled by the Integrated Furnace Control
- Blower speeds are easily changed on the integrated furnace control. See Blower Data tables

#### Blower Assembly

- Lennox designed and built, direct drive blower
- Each blower is statically and dynamically balanced as an assembly before installation in the unit
- Blower motor is resiliently mounted to blower assembly
- Blower is easily removed for servicing

## FEATURES

### CONTROLS

#### 11 SureLight® Integrated Furnace Control

- Contains all necessary controls and relays to operate furnace
- Combustion air inducer is operated by the integrated furnace control
- Prior to ignition, a pre-purge cycle for 15 seconds is initiated
- After the main burners are turned off, a post-purge cycle for 5 seconds is run
- Flame sensor assures safe and reliable operation
- Should loss of flame occur the integrated furnace control will initiate 4 re-attempts at ignition before locking out unit operation for 60 minutes
- Watchguard type circuit automatically resets ignition controls after one hour of continuous thermostat demand after unit lockout, eliminating nuisance calls for service
- Fan control consists of adjustable blower timed-off delay (60, 90, 120, 180 seconds - factory setting 90 seconds) and fixed blower timed-on delay (30 seconds - heating, 2 seconds - cooling)
- For air-conditioning applications, blower is automatically energized on thermostat demand for cooling
- Control has low speed continuous blower speed setting for humidifier or air cleaner operation
- Two accessory terminals furnished for additional power supply requirements for 120 volt (less than 1 amp) power humidifiers and powered air cleaners
- One additional terminal is furnished for power supply requirements for 24V (less than 0.5 amp) low voltage accessories
- Ignition control has single red LED to indicate status and as an aid in troubleshooting
- Last five codes are stored in non-volatile memory (accessible by recall button on control) for servicing

#### 24 Volt Transformer

- Factory installed on outside of control box
- 40VA transformer has fuse wired in series

#### Field Wiring Make-up Box

- Furnished for line voltage wiring
- Factory installed internally on left side of furnace
- Box may be installed on right side of furnace

### Optional Accessories

#### iComfort® M30 Smart Wi-Fi Thermostat

- Wi-Fi-enabled, electronic 7-day, universal, multi-stage, programmable, touchscreen thermostat
- 4 Heat/2 Cool
- Auto-changeover
- Dual-fuel control with optional outdoor sensor
- Controls dehumidification during cooling mode and humidification during heating mode
- Offers enhanced capabilities including humidification / dehumidification / dewpoint measurement and control, Humiditrol® control, and equipment maintenance reminders
- Easy to read 4.3 in. color touchscreen (measured diagonally)
- LCD display with backlight shows the current and set temperature, time, inside relative humidity, system status (operating mode and schedules) and outside temperature (optional outdoor sensor required)
- Smooth Setback Recovery starts system early to achieve setpoint at start of program period
- Compressor short-cycle protection (5 minutes)
- Up to four separate schedules are available plus Schedule IQ™
- One-Touch Away Mode - A quick and easy way to set the cooling and heating setpoints while away
- Smart Away™ - Uses geo-fencing technology to determine when the homeowner is within a predetermined distance from the home to operate the system when leaving, away and arriving
- Wi-Fi remote monitoring and adjustment through a home wireless network for desktop PCs, laptops and apps for smartphones or tablets
- Smart home automation compatible with Amazon Alexa®, Google Assistant and IFTTT

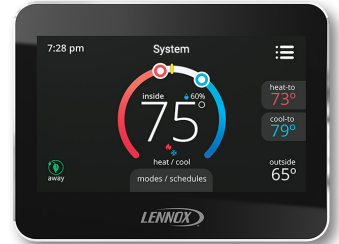

**NOTE** - See the iComfort® M30 Smart Wi-Fi Thermostat Product Specifications bulletin in the Controls section for more information.

#### Remote Outdoor Temperature Sensor

- Used with the iComfort® M30 Smart Thermostat
- Outdoor sensor allows thermostat to display outdoor temperature

**NOTE** - Sensor is required for the Enhanced Dehumidification Accessory (EDA).



#### Thermostat

- Thermostat is not furnished with unit
- Lennox Price Book for selection

## SPECIFICATIONS

Gas	Model No.	ML180DF045E36A	ML180DF070E36A	ML180DF070E36B
<b>Heating Performance</b>	<sup>1</sup> AFUE	80%	80%	80%
	Input - Btuh	44,000	66,000	66,000
	Output - Btuh	36,000	54,000	54,000
	Temperature rise range - °F	15 - 45	30 - 60	30 - 60
Gas Manifold Pressure (in. w.g.) Nat. Gas / LPG/Propane		3.5 / 10.0	3.5 / 10.0	3.5 / 10.0
<b>High Static - in. w.g.</b>		0.50	0.50	0.50
<b>Connections in.</b>	Flue connection - in. round	4	4	4
	Gas pipe size IPS	1/2	1/2	1/2
<b>Indoor Blower</b>	Wheel nom. dia. x width - in.	10 x 8	10 x 10	10 x 10
	Motor Type	DC Brushless	DC Brushless	DC Brushless
	Motor output - hp	1/2	1/2	1/2
	Tons of add-on cooling	1.5 - 3	1.5 - 3	1.5 - 3
	Air Volume Range - cfm	355 - 1430	675 - 1460	430 - 1475
<b>Electrical Data</b>	Voltage	120 volts - 60 hertz - 1 phase		
Blower motor full load amps		6.8	6.8	6.8
Maximum overcurrent protection		15	15	15
<b>Shipping Data</b>	lbs. - 1 package	113	119	128

NOTE - Filters and provisions for mounting are not furnished and must be field provided.

<sup>1</sup> Annual Fuel Utilization Efficiency based on DOE test procedures and according to FTC labeling regulations. Isolated combustion system rating for non-weatherized furnaces.

## SPECIFICATIONS

Gas	Model No.	ML180DF090E48B	ML180DF110E60C
<b>Heating Performance</b>	<sup>1</sup> AFUE	80%	80%
	Input - Btuh	88,000	110,000
	Output - Btuh	72,000	90,000
	Temperature rise range - °F	30 - 60	30 - 60
Gas Manifold Pressure (in. w.g.) Nat. Gas / LPG/Propane		3.5 / 10.0	3.5 / 10.0
<b>High Static - in. w.g.</b>		0.50	0.50
<b>Connections in.</b>	Flue connection - in. round	4	4
	Gas pipe size IPS	1/2	1/2
<b>Indoor Blower</b>	Wheel nom. dia. x width - in.	10 x 10	11-1/2 x 10
	Motor Type	DC Brushless	DC Brushless
	Motor output - hp	3/4	1
	Tons of add-on cooling	2.5 - 4	3 - 5
	Air Volume Range - cfm	680 - 1750	990 - 2410
<b>Electrical Data</b>	Voltage	120 volts - 60 hertz - 1 phase	
Blower motor full load amps		8.4	10.9
Maximum overcurrent protection		15	15
<b>Shipping Data</b>	lbs. - 1 package	140	160

NOTE - Filters and provisions for mounting are not furnished and must be field provided.

<sup>1</sup> Annual Fuel Utilization Efficiency based on DOE test procedures and according to FTC labeling regulations. Isolated combustion system rating for non-weatherized furnaces.

## OPTIONAL ACCESSORIES - ORDER SEPARATELY

	"A" Width Models	"B" Width Models	"C" Width Models
<b>CABINET ACCESSORIES</b>			
Downflow Combustible Flooring Base	11M59	11M60	11M61
<b>CONTROLS</b>			
iComfort® M30 Smart Wi-Fi Thermostat	15Z69	15Z69	15Z69
Remote Outdoor Air Temperature Sensor	X2658	X2658	X2658
Blower Relay Kit (for two-stage outdoor units)	85W66	85W66	85W66
Furnace Twinning Kit	16W72	16W72	16W72
<b>FILTERS</b>			
<sup>1</sup> Downflow Filter Cabinet	51W06	51W07	51W08
	No. and Size of filter - in.	(1) 20 x 20 x 1	(2) 20 x 16 x 1
<b>NIGHT SERVICE KIT</b>			
Night Service Kit	84W47	84W47	84W47

<sup>1</sup> Cleanable polyurethane, frame-type filter.

## GAS HEAT ACCESSORIES

Input	High Altitude Pressure Switch Kit			Natural Gas to LPG/Propane Kit		LPG/Propane to Natural Gas Kit	Natural Gas High Altitude Orifice Kit
	0 - 4500 ft.	4501 - 7500 ft.	7501 - 10,000 ft.	0 - 7500 ft.	7501 - 10,000 ft.	0 - 7500 ft.	7501 - 10,000 ft.
045	No Change	No Change	80W51	11K49	11K44	73W81	73W37
070	No Change	80W52	80W51	11K49	11K44	73W81	73W37
090	No Change	No Change	80W51	11K49	11K44	73W81	73W37
110	No Change	80W52	80W51	11K49	11K44	73W81	73W37

## HIGH ALTITUDE DERATE

NOTE - Units may be installed at altitudes up to 4500 ft. above sea level without any modifications.

At altitudes above 4500 ft. units must be derated to match information in the shaded areas shown below.

NOTE - This is the only permissible derate for these units.

Input	Gas Manifold Pressure (Outlet) in. w.g.						Line Pressure - in. w.g.		
	0 - 4500 Feet		4501 - 7500 Feet		7501 - 10,000 ft.		Minimum		Maximum
	Natural Gas	LPG/Propane	Natural Gas	LPG/Propane	<sup>1</sup> Natural Gas	LPG/Propane	Natural Gas	LPG/Propane	
045	3.5	10	3.5	10	3.5	10	4.5	11	13
070	3.5	10	3.3	10	3.5	10	4.5	11	13
090	3.5	10	3.3	10	3.5	10	4.5	11	13
110	3.5	10	3.3	10	3.5	10	4.5	11	13

<sup>1</sup> Natural Gas High Altitude Orifice Kit required.

# DIMENSIONS - UNIT

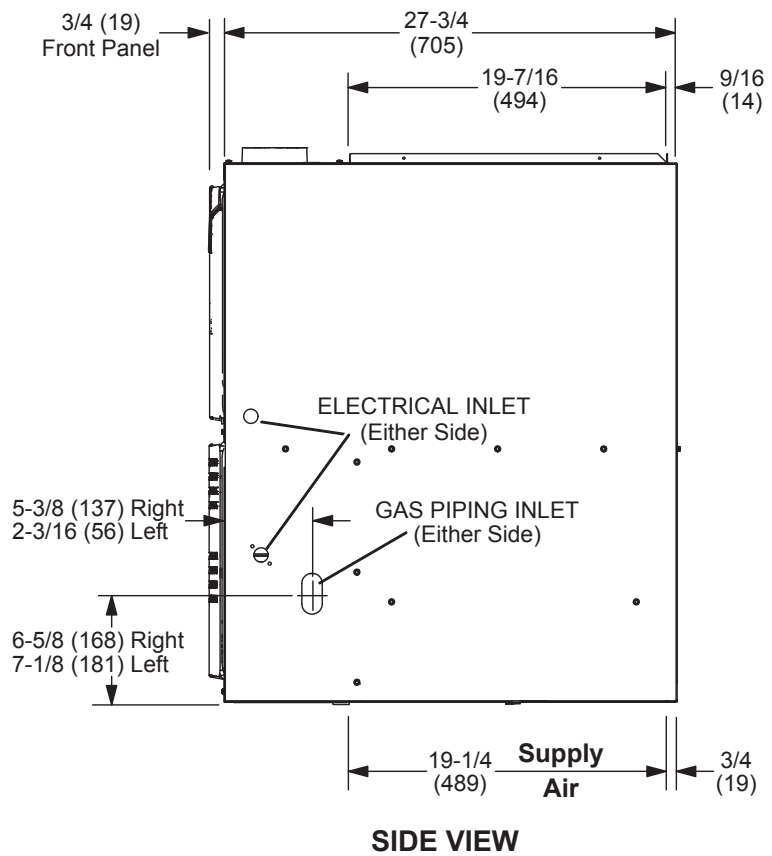
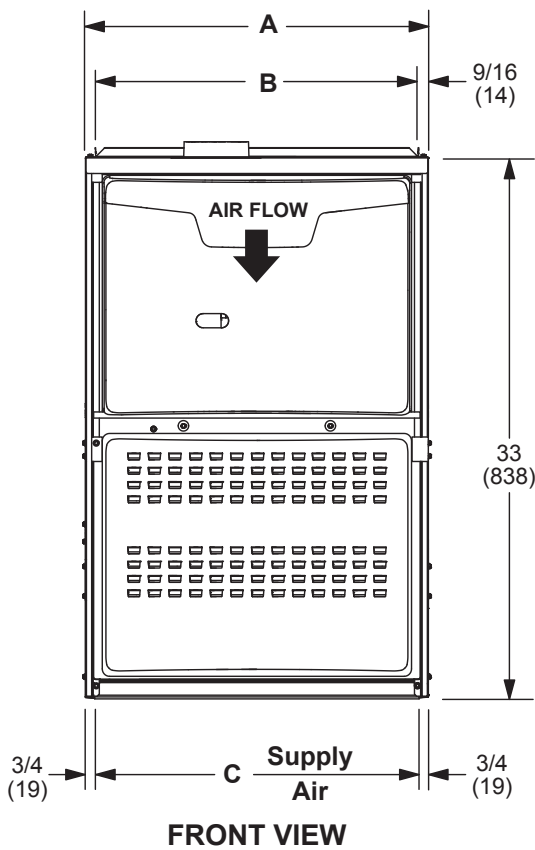
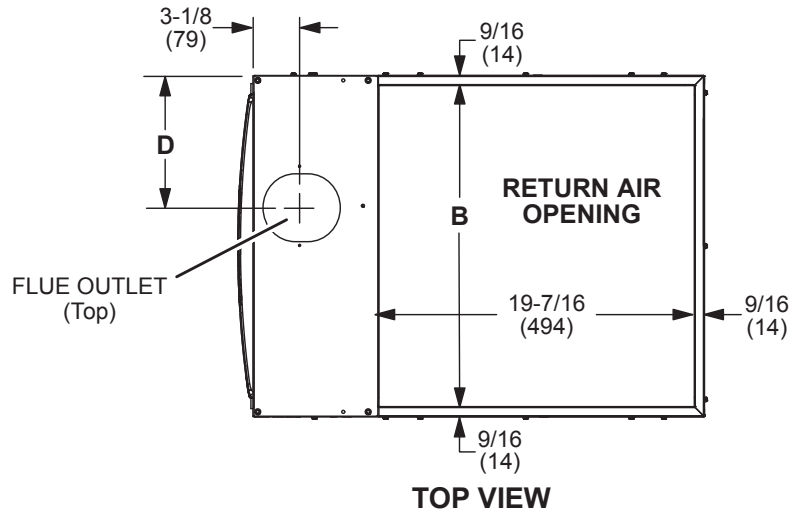

Model No.	A		B		C		D	
	in.	mm	in.	mm	in.	mm	in.	mm
ML180DF045E36A ML180UH070E36A	14-1/2	368	13-3/8	340	13	330	4-3/4	121
ML180DF070E36B ML180DF090E48B	17-1/2	446	16-3/8	416	16	406	6-1/4	159
ML180DF110E60C	21	533	19-7/8	505	19-1/2	495	8	203



## DIMENSIONS - OPTIONAL ACCESSORIES

### DOWNFLOW FILTER CABINET

**"A" WIDTH FURNACES  
(Single Filter)**

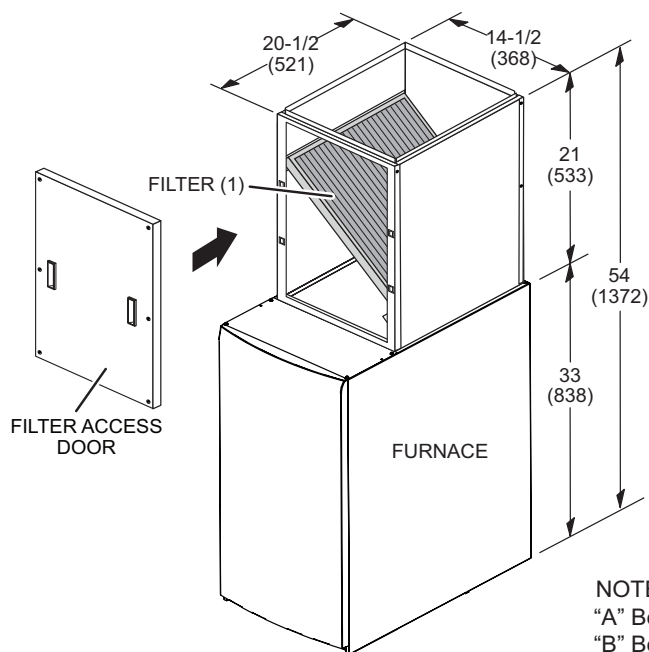

**"B AND "C" WIDTH FURNACES  
(Two Filters)**

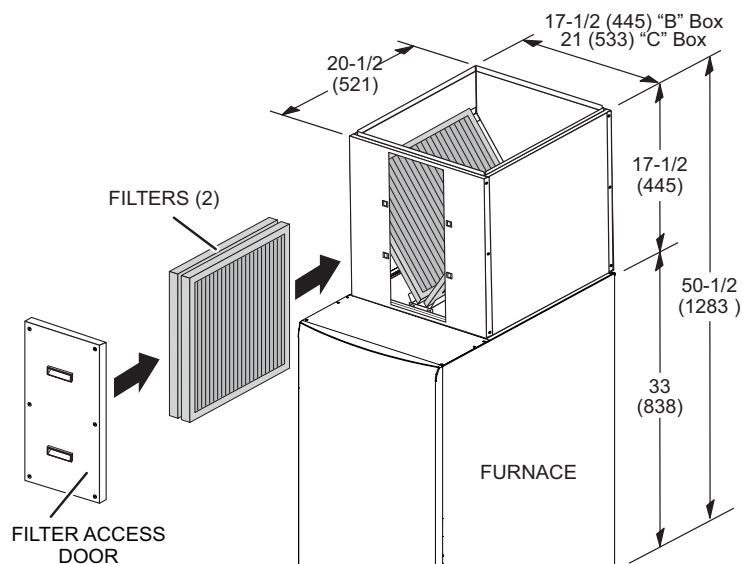

NOTE: Return Air Opening (W x D)  
 "A" Box 13-1/2 x 19-5/8 (343 x 498)  
 "B" Box 16-1/2 x 19-5/8 (419 x 498)  
 "C" Box 20 x 19-5/8 (508 x 498)

### INSTALLATION CLEARANCES

Vent Type	Type B1	Type C
Sides	0 in. (0 mm)	<sup>1</sup> 0 (0)
Rear	0 in. (0 mm)	0 (0)
Top	1 in. (25 mm)	1 (25)
Front	2-1/4 in. (57 mm)	2-1/4 (57)
Front (service/alcove)	24 in. (610 mm)	24 (610)
Floor	<sup>2</sup> Combustible	<sup>2</sup> Combustible
Flue	1 in. (25 mm)	6 (152)

NOTE - Air for combustion must conform to the methods outlined in the National Fuel Gas Code (NFPA 54/ANSI-Z223.1).

NOTE - In the U.S. flue sizing must conform to the methods outlined in the current National Fuel Gas Code (NFPA 54/ANSI-Z223.1) or applicable provisions of local building codes.

<sup>1</sup> Left side requires 4 in. if single wall vent is used on 14-1/2 in. "A" width cabinets, 2 in. on 17-1/2 in. "B" width cabinets.

<sup>2</sup> Clearance for installation on combustible floor if Optional Downflow Combustible Flooring Base is installed between furnace and combustible floor. Not required in add-on cooling applications if installed in accordance with local codes, National Fuel Gas Code ANSI-Z223.1 or National Standard of Canada CAN/CSA-B149.1 and CAN/CSA-B149.2 Installation Code for Gas Burning Appliances". Do not install the furnace directly on carpeting, tile, or other combustible materials other than wood flooring.

## DIMENSIONS - OPTIONAL ACCESSORIES

### DOWNFLOW COMBUSTIBLE FLOORING BASE

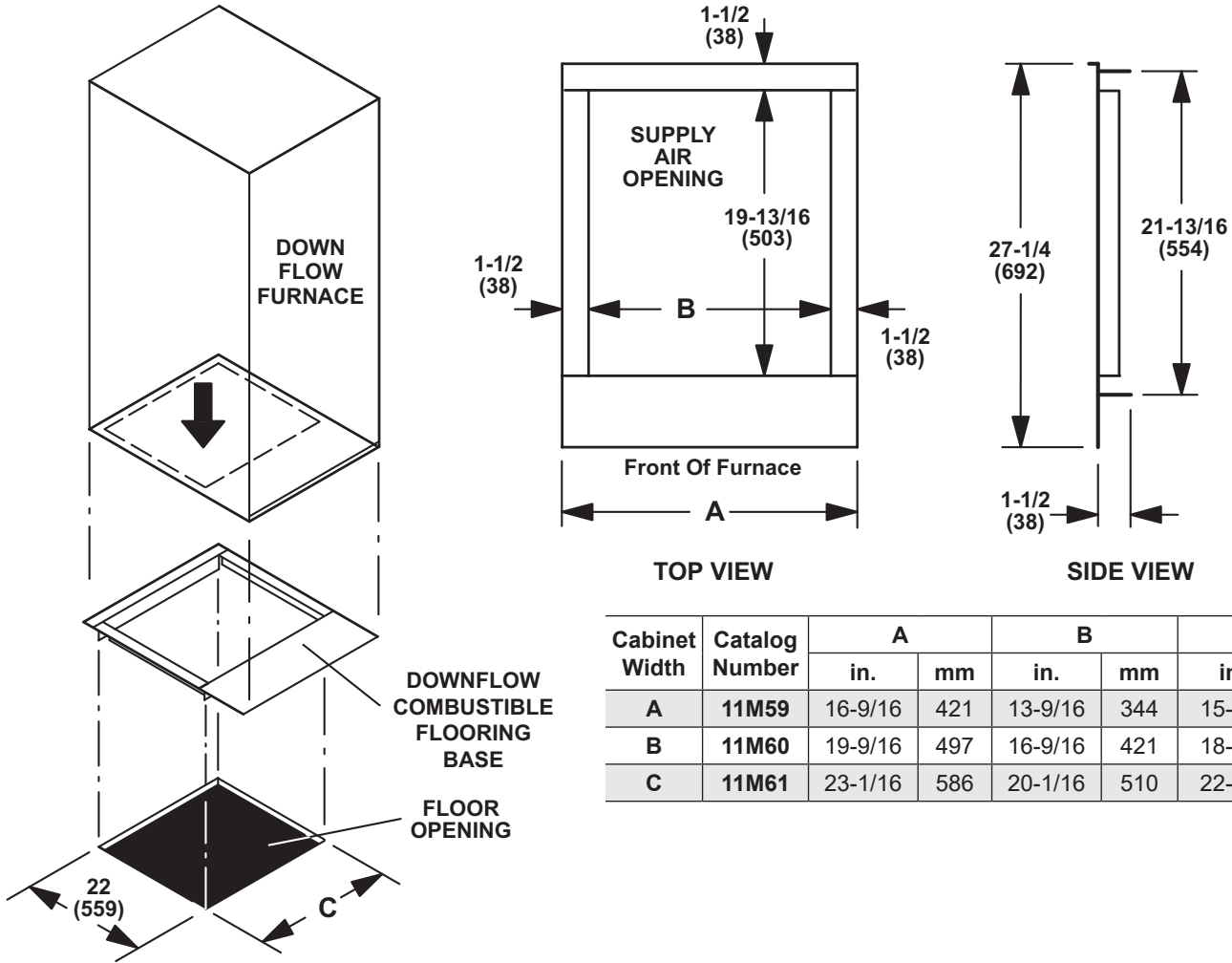

Cabinet Width	Catalog Number	A		B		C	
		in.	mm	in.	mm	in.	mm
A	11M59	16-9/16	421	13-9/16	344	15-3/4	400
B	11M60	19-9/16	497	16-9/16	421	18-3/4	476
C	11M61	23-1/16	586	20-1/16	510	22-1/4	565

## DIMENSIONS - FURNACE/COIL COMBINED DIMENSIONS

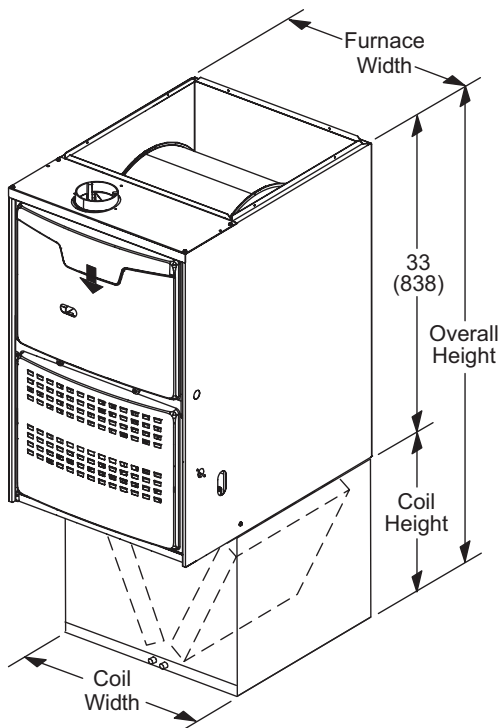

Model Number	Coil Width		Furnace Width		Coil Height		Overall Height	
	in.	mm	in.	mm	in.	mm	in.	mm
CR33-18A-F	17-1/2	446	14-1/2	368	14-1/8	359	47-1/8	1197
CR33-24A-F	17-1/2	446	14-1/2	368	14-1/8	359	47-1/8	1197
CR33-24B-F	17-1/2	446	17-1/2	446	14-1/8	359	47-1/8	1197
CR33-30/36A-F	17-1/2	446	14-1/2	368	16-1/8	410	49-1/8	1248
CR33-30/36B-F	17-1/2	446	17-1/2	446	16-1/8	410	49-1/8	1248
CR33-30/36C-F	21	533	21	533	16-1/8	410	49-1/8	1248
CR33-48B-F	21	533	17-1/2	446	20	508	53	1346
CR33-48C-F	21	533	21	533	20	508	53	1346
CR33-50/60C-F	24-1/2	622	21	533	23-5/8	600	56-5/8	2276

## BLOWER DATA

### ML180DF045E36A PERFORMANCE (Less Filter)

External Static Pressure in. w.g.	Air Volume / Watts at Various Blower Speeds									
	High		Medium-High		Medium		Medium-Low		Low	
	cfm	Watts	cfm	Watts	cfm	Watts	cfm	Watts	cfm	Watts
0.00	1430	285	1215	180	1035	120	995	110	930	100
0.10	1400	285	1175	185	995	130	885	100	850	90
0.20	1375	300	1145	200	950	140	840	110	725	85
0.30	1335	315	1120	210	915	145	790	115	665	95
0.40	1320	325	1075	220	870	155	745	125	625	100
0.50	1275	335	1045	230	835	165	715	135	565	105
0.60	1245	345	1000	235	785	170	655	140	520	115
0.70	1215	355	970	245	745	180	605	150	355	130
0.80	1175	365	925	255	695	185	555	155	400	130

### ML180DF070E36A PERFORMANCE (Less Filter)

External Static Pressure in. w.g.	Air Volume / Watts at Various Blower Speeds									
	High		Medium-High		Medium		Medium-Low		Low	
	cfm	Watts	cfm	Watts	cfm	Watts	cfm	Watts	cfm	Watts
0.00	---	---	---	---	---	---	---	---	---	---
0.10	1460	348	1235	221	1150	179	1110	164	965	114
0.20	1420	360	1195	233	1115	193	1090	175	920	116
0.30	1395	371	1175	245	1070	196	1055	181	900	126
0.40	1375	380	1150	247	1045	207	1025	191	845	130
0.50	1335	378	1120	259	1010	211	990	198	820	143
0.60	1285	374	1075	260	985	221	955	206	770	144
0.70	1210	356	1065	274	955	225	915	209	730	154
0.80	1140	333	1020	276	920	237	890	219	675	158

### ML180DF070E36B PERFORMANCE (Less Filter)

External Static Pressure in. w.g.	Air Volume / Watts at Various Blower Speeds									
	High		Medium-High		Medium		Medium-Low		Low	
	cfm	Watts	cfm	Watts	cfm	Watts	cfm	Watts	cfm	Watts
0.00										
0.10	1430	290	1275	175	1190	145	1155	135	1005	95
0.20	1400	295	1230	190	1125	160	1110	150	900	100
0.30	1360	310	1205	205	1085	160	1055	155	845	115
0.40	1310	325	1155	210	1050	175	1000	165	790	115
0.50	1280	335	1110	220	985	185	950	180	705	130
0.60	1250	350	1060	235	935	195	865	185	645	135
0.70	1220	355	1000	245	865	205	815	195	590	140
0.80	1165	365	935	250	795	210	750	200	480	145

### ML180DF090E48B PERFORMANCE (Less Filter)

External Static Pressure in. w.g.	Air Volume / Watts at Various Blower Speeds									
	High		Medium-High		Medium		Medium-Low		Low	
	cfm	Watts	cfm	Watts	cfm	Watts	cfm	Watts	cfm	Watts
0.00	1750	385	1550	265	1430	205	1355	185	1195	130
0.10	1725	390	1495	270	1390	220	1320	195	1145	140
0.20	1695	405	1470	285	1340	235	1280	210	1105	145
0.30	1660	415	1425	300	1290	240	1225	215	1040	160
0.40	1615	430	1395	310	1250	255	1185	230	1005	170
0.50	1570	450	1360	325	1210	265	1145	240	945	180
0.60	1545	465	1295	340	1165	280	1085	255	865	185
0.70	N/A	N/A	1265	350	1120	295	1040	265	810	200
0.80	N/A	N/A	1215	365	1080	305	1000	275	755	210

## BLOWER DATA

### ML180DF110E60C PERFORMANCE (Less Filter)

External Static Pressure in. w.g.	Air Volume / Watts at Various Blower Speeds									
	High		Medium-High		Medium		Medium-Low		Low	
	cfm	Watts	cfm	Watts	cfm	Watts	cfm	Watts	cfm	Watts
0.00	2410	625	2095	405	1875	295	1700	225	1635	180
0.10	2385	630	2100	415	1830	310	1610	240	1505	190
0.20	2325	650	2010	440	1760	330	1570	255	1375	195
0.30	2280	675	1940	460	1705	340	1500	260	1320	210
0.40	2235	690	1895	475	1635	365	1440	285	1265	225
0.50	2165	710	1845	490	1595	380	1380	300	1200	235
0.60	2125	735	1800	510	1545	390	1320	310	1170	250
0.70	2090	740	1755	530	1510	405	1285	325	1100	260
0.80	2035	760	1700	540	1460	425	1255	345	1030	275

## REVISIONS

Sections	Description of Change
Document	Specifications, ratings, blower and dimensions added for model - ML180DF070E36A.



Visit us at [www.lennox.com](http://www.lennox.com)

For the latest technical information, [www.LennoxPros.com](http://www.LennoxPros.com)

Contact us at 1-800-4-LENNOX

NOTE - Due to Lennox' ongoing commitment to quality, Specifications, Ratings and Dimensions subject to change without notice and without incurring liability. Improper installation, adjustment, alteration, service or maintenance can cause property damage or personal injury. Installation and service must be performed by a qualified installer and servicing agency.

©2019 Lennox Industries, Inc.