



GAS FURNACES

ML180UHE

MERIT® SERIES

Upflow / Horizontal - Constant Torque Blower Motor - 60 Hz

**RESIDENTIAL
PRODUCT SPECIFICATIONS**

Bulletin No. 210825
September 2019
Supersedes April 2019

**MERIT®
SERIES**



AFUE - 80%
Input - 44,000 to 132,000 Btuh
Nominal Add-on Cooling - 1.5 to 5 Tons

MODEL NUMBER IDENTIFICATION

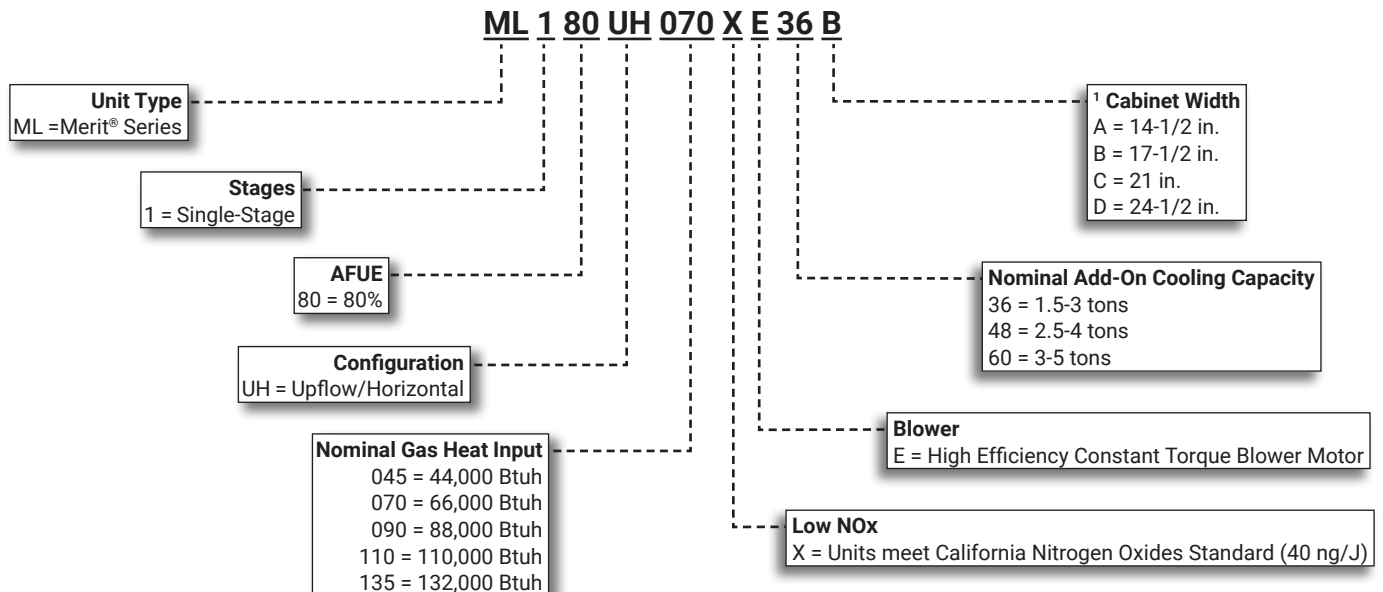

¹ Indoor coils with the same letter designation physically match the furnace.

FEATURE HIGHLIGHTS

1. Lennox Duralok™ Heat Exchanger Assembly
2. Inshot Burners
3. SureLight® Hot Surface Ignitor
4. Gas Control Valve
5. Combustion Air Inducer
6. Flame Rollout Switches
7. Power Saver™ Constant Torque Blower
8. SureLight® Integrated Furnace Control
9. Insulated Cabinet
10. Safety Interlock Switch
11. Gas Piping And Electrical Inlets

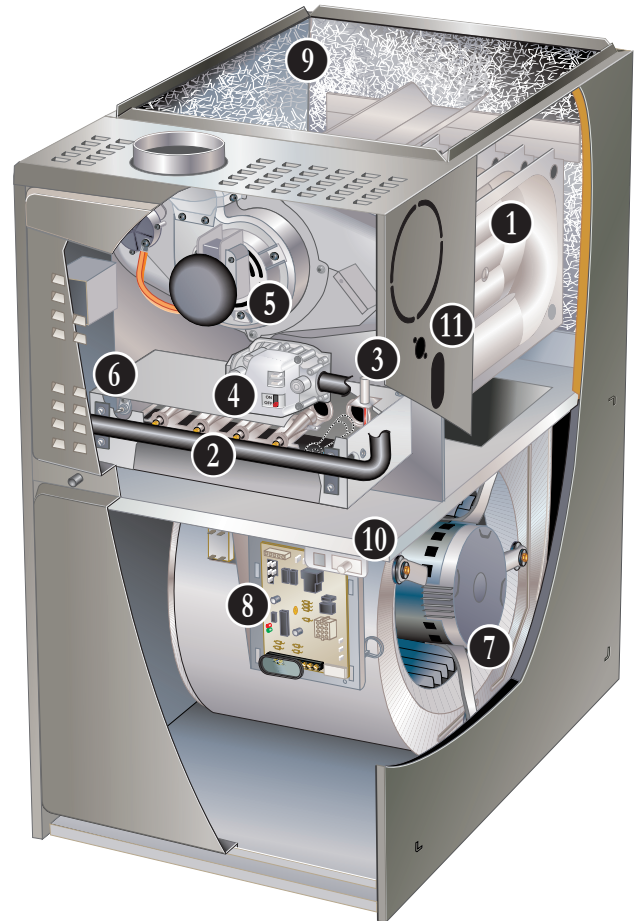

NOTE - ML180E FURNACES ARE NOT AVAILABLE IN CANADA!

CONTENTS

Approvals and Warranty	3
Blower Data	15
Dimensions - Furnace/Coil Combined Dimensions	14
Dimensions - Optional Accessories	13
Dimensions - Unit - Horizontal Position	12
Dimensions - Unit - Upflow Position	11
Gas Heat Accessories	10
High Altitude Derate	10
Installation Clearances	9
Optional Accessories - Order Separately	10
Specifications	9

APPROVALS AND WARRANTY

APPROVALS

- AHRI Certified
- Tested and rated according to US DOE test procedures and FTC labeling regulations
- "X" models approved by the California Energy Commission and meets California Nitrogen Oxides Standard (NOx) limits of 40 ng/J
- ISO 9001 Registered Manufacturing Quality System
- Blower data from unit tests conducted in Lennox Laboratory air test chamber

California Only

- If installed in South Coast Air Quality Management District (SCAQMD) only
 - This furnace does not meet the SCAQMD Rule 1111 NOx emission limit (14 ng/J), and thus is subject to a mitigation fee of up to \$450. This furnace is not eligible for the Clean Air Furnace Rebate Program: www.CleanAirFurnaceRebate.com
- If installed in San Joaquin Valley Air Pollution Control District (SJVAPCD) only
 - This furnace does not meet the SJVAPCD Rule 4905 NOx emission limit (14 ng/J), and thus is subject to a mitigation fee of up to \$450

WARRANTY

- Heat Exchanger:
 - Limited twenty years in residential applications
 - Limited ten years in non-residential applications
- All other covered components:
 - Limited five years in residential installations
 - Limited one year in non-residential installations

NOTE - Refer to Lennox Equipment Limited Warranty certificate included with unit for specific details.

FEATURES

APPLICATIONS

- Input capacities of 44,000, 66,000, 88,000, 110,000 and 132,000 Btuh
- Energy efficiency (AFUE) - 80%
- Compact cabinet
- Upflow, horizontal-left or horizontal-right applications
- Lennox add-on indoor coils, high-efficiency air cleaners and humidifiers can easily be added to furnace
- Shipped factory assembled with all controls installed and wired
- Ready for installation in upflow or horizontal right-hand position without any modifications

NOTE - Horizontal left-hand position requires repositioning of pressure switch.

- Removable bottom seal panel shipped in place for side return air is easily removed for bottom/end return air applications
- Each unit factory test operated to ensure proper operation

HEATING SYSTEM

- 1 **Lennox Duralok™ Heat Exchanger Assembly**
 - Heavy gauge aluminized steel heat exchanger
 - Crimped seam clamshell type design
 - Designed for normal expansion and contraction
 - Minimum resistance to air flow
 - Laboratory life cycle tested in excess of industry standards
 - Compact size permits low overall design of furnace cabinet
- 2 **Inshot Burners**
 - Aluminized steel inshot burners provide efficient, trouble-free operation
 - Burner venturi mixes air and gas in correct proportion for proper combustion
 - Burner assembly is removable from the unit as a single component for ease of service
- 3 **SureLight® Hot Surface Ignitor**
 - Tough, reliable, long-life, trouble-free performance
 - Silicon nitride ignitor
 - Cemented to steatite block for protection against current leakage
 - Ignition leads are constructed of nickel plated copper and are enclosed in high temperature Teflon® insulation for dependable operation

FEATURES

HEATING SYSTEM (continued)

- 4 **Gas Control Valve**
 - 24 volt redundant combination gas control valve combines manual shut off switch (On-Off), automatic electric valve (dual) and gas pressure regulation into a compact combination control
- 5 **Combustion Air Inducer**
 - Shaded pole heavy duty blower prepurges heat exchanger and safely vents flue products
 - Pressure switch proves blower operation before allowing gas valve to open
 - Operates only during heating cycle
 - Direct access allows inducer assembly to be rotated 90° clockwise or counterclockwise to facilitate easy vent attachment from either side of the cabinet in upflow applications and from the top in horizontal applications
- 6 **Flame Rollout Switches (2)**
 - Factory installed on the front of the burner box
 - Switches provides protection from abnormal operating conditions
 - Manual reset

Limit Control

- Primary limit is accurately located on vestibule panel
- Automatic reset

Optional Accessories

High Altitude Pressure Switch Kit

- Required on most units for proper unit operation at altitudes from 4,501 to 7500 ft.

Natural Gas to LPG/Propane Conversion Kit

- Required for field changeover from natural gas to LPG/Propane

LPG/Propane to Natural Gas Conversion Kit

- Required for field changeover from LPG/Propane to natural gas

Vent Adaptor (Upflow Applications Only)

- Allows venting through a masonry chimney without the need of a flue liner
- Manual reset temperature sensor protects against abnormal operating conditions
- Sensor wiring may be routed from either side of adaptor
- Minimum winter design temperatures:
 - -10°F when used with interior masonry chimneys
 - +5°F when used with exterior masonry chimneys

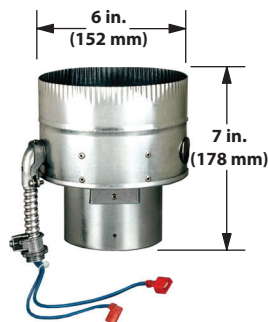

NOTE - Refer to Winter Design Temperatures Map on page 8 for application information. Also refer to the installation instructions for detailed information.

BLOWER

- 7 **Power Saver™ Constant Torque Blower Motor**
 - Programmable high efficiency multi-speed blower motor. By maintaining constant torque output, blower motor can deliver more uniform (but not constant) airflow over the static pressure range
 - Programmable multi-speed operation is achieved by the use of an ECM (Electronically Commutated Motor) motor
 - Leadless blower motor features simple plug-in connections
 - Controlled by the Integrated Furnace Control
 - Blower speeds are easily changed on the integrated furnace control. See Blower Data tables
- #### Blower Assembly
- Lennox designed and built, direct drive blower
 - Each blower is statically and dynamically balanced as an assembly before installation in the unit
 - Blower motor is resiliently mounted to blower assembly
 - Blower is easily removed for servicing

FEATURES

CONTROLS

8 SureLight® Integrated Furnace Control

- Contains all necessary controls and relays to operate furnace
- Combustion air inducer is operated by the integrated furnace control
- Prior to ignition, a pre-purge cycle for 15 seconds is initiated
- After the main burners are turned off, a post-purge cycle for 5 seconds is run
- Flame sensor assures safe and reliable operation
- Should loss of flame occur the integrated furnace control will initiate 4 re-attempts at ignition before locking out unit operation for 60 minutes
- Watchguard type circuit automatically resets ignition controls after one hour of continuous thermostat demand after unit lockout, eliminating nuisance calls for service
- Fan control consists of adjustable blower timed-off delay (60, 90, 120, 180 seconds - factory setting 90 seconds) and fixed blower timed-on delay (30 seconds - heating, 2 seconds - cooling)
- For air-conditioning applications, blower is automatically energized on thermostat demand for cooling
- Control has low speed continuous blower speed setting for humidifier or air cleaner operation
- Two accessory terminals furnished for additional power supply requirements for 120 volt (less than 1 amp) power humidifiers and powered air cleaners
- One additional terminal is furnished for power supply requirements for 24V (less than 0.5 amp) low voltage accessories
- Ignition control has single red LED to indicate status and as an aid in troubleshooting
- Last five codes are stored in non-volatile memory (accessible by recall button on control) for servicing

24 Volt Transformer

- Factory installed on outside of control box
- 40VA transformer has fuse wired in series

Field Wiring Make-up Box

- Furnished for line voltage wiring
- Factory installed internally on left side of furnace
- Box may be installed on right side of furnace

Optional Accessories

iComfort® M30 Smart Wi-Fi Thermostat

- Wi-Fi-enabled, electronic 7-day, universal, multi-stage, programmable, touchscreen thermostat
- 4 Heat/2 Cool
- Auto-changeover
- Dual-fuel control with optional outdoor sensor
- Controls dehumidification during cooling mode and humidification during heating mode
- Offers enhanced capabilities including humidification / dehumidification / dewpoint measurement and control, Humiditrol® control, and equipment maintenance reminders
- Easy to read 4.3 in. color touchscreen (measured diagonally)
- LCD display with backlight shows the current and set temperature, time, inside relative humidity, system status (operating mode and schedules) and outside temperature (optional outdoor sensor required)
- Smooth Setback Recovery starts system early to achieve setpoint at start of program period
- Compressor short-cycle protection (5 minutes)
- Up to four separate schedules are available plus Schedule IQ™
- One-Touch Away Mode - A quick and easy way to set the cooling and heating setpoints while away
- Smart Away™ - Uses geo-fencing technology to determine when the homeowner is within a predetermined distance from the home to operate the system when leaving, away and arriving
- Wi-Fi remote monitoring and adjustment through a home wireless network for desktop PCs, laptops and apps for smartphones or tablets
- Smart home automation compatible with Amazon Alexa®, Google Assistant and IFTTT

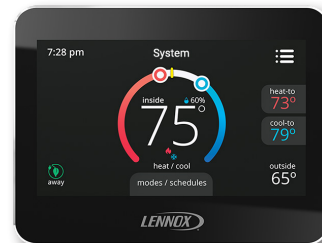

NOTE - See the iComfort® M30 Smart Wi-Fi Thermostat Product Specifications bulletin in the Controls section for more information.

Remote Outdoor Temperature Sensor

- Used with the iComfort® M30 Smart Wi-Fi Thermostat
- Outdoor sensor allows thermostat to display outdoor temperature

NOTE - Sensor is required for the Enhanced Dehumidification Accessory (EDA).

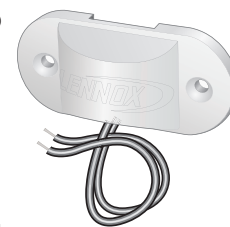

Thermostat

- Thermostat is not furnished with unit
- Lennox Price Book for selection

FEATURES

CONTROLS (continued)

Optional Accessories

Blower Relay Kit

(For Use With Two-Stage Outdoor Units)

- Allows furnace blower speed changes when matched with two-stage air conditioners or heat pumps

Furnace Twinning Kit

- Required to operate two furnaces simultaneously
- Kit consists of twinning relays, quick connect terminals and mounting hardware
- Used for single-stage heating/single-stage cooling with a single-stage thermostat

Night Service Kit

- Contains most commonly used service parts:
 - Furnace Control
 - Ignitor
 - Flame Sensor
 - Gas Valve
 - Transformer

FILTER (Not Furnished)

- Filter and provisions for external mounting must be field provided

Optional Accessories

Air Filter and Rack Kit for Horizontal Return Air (End) Applications

- Washable or vacuum cleanable polyurethane frame type filter and external end return air rack
- Rack has filter door for servicing
- Flanges on rack for duct connection
- Field installed
- See dimension drawing

Air Filter and Rack Kit for Upflow Side Return Air

NOTE - Not for use with Return Air Base

- Washable or vacuum cleanable polyurethane frame type filter and external side return air rack available for field installation
- Available in single and ten pack kits
- Rack has filter door for servicing
- Flanges on rack for duct connection
- Field installs on either side of unit cabinet
- See dimension drawing

CABINET

- Low-profile, narrow width allows easy installation
- Heavy-gauge, cold rolled steel construction
- Pre-painted cabinet finish
- Flue outlet on top of cabinet for upflow applications, can be relocated to either side of cabinet for horizontal applications
- Flanges provided on supply air opening for ease of plenum connection or alignment with indoor coil
- 9 • Insulated with foil faced insulation on sides and back of heating compartment
- Sealed blower compartment
- Inner blower compartment access panel seals blower compartment from air leakage
- Complete service access
- 10 • Safety interlock switch automatically shuts off power to unit when blower compartment access panel is removed
- 11 • Gas piping and electrical inlets are provided in both sides of cabinet

Low Leakage Cabinet

- All models have less than 2% air leakage
- Meets ANSI/ASHRAE Standard 193-2010 "Method of Test for Determining the Air Tightness of HVAC Equipment"

Bottom/Side Return Air Entry:

- Upflow/horizontal with bottom return air entry:
 - Remove furnished bottom seal panel from cabinet
- Upflow only with side return-air entry:
 - Corners are marked on either side of cabinet for return air cut-out
- See dimension drawings

NOTE - 60C and 60D size units that require air volumes over 1800 cfm must have one of the following:

- Single side return air and Optional Return Air Base with transition that must accommodate required 20 x 25 x 1 inch air filter to maintain proper velocity
- Bottom return air
- Return air from both sides
- Bottom and one side return air
- See Blower Performance Tables for additional information

FEATURES

CABINET (continued)

Coil Match-Up

- All furnaces exactly match Lennox cased upflow indoor coils and horizontal indoor coils with same letter designation (A, B, C, D) in model number
- No adaptor required
- Engaging holes furnished on cabinet for alignment
- Lennox uncased coils match furnaces without any overhang but require an optional adaptor base or field fabricated transition to match furnace opening
- See coil bulletin for additional information

Optional Accessories

Horizontal Suspension Kit

- Provides suspension of unit and indoor coil in horizontal applications
- Allows complete service access
- Consists of corner mounted hanging brackets with vibration isolators, return air end support rail and hardware for assembly
- Metal hanging straps must be field provided

Return Air Base

NOTE - On furnaces with side return air and condensate trap on the same side of the cabinet, a field fabricated transition or Return Air Base is required when using an IAQ product higher than 14-3/16 inches installed next to the unit and serviced from the front. IAQ products higher than 20 inches require a field fabricated transition.

NOTE - Must be used for 60C and 60D size models with air volumes over 1800 cfm in upflow applications when only one side return is required.

- Cabinet is shipped flat for easy field assembly
- Pre-painted steel to match the furnace
- See Dimension Drawing

High Performance Economizer (Commercial Applications Only)

- Designed for applications requiring outdoor air to be utilized in a commercial HVAC system
- Allows the entry of fresh outdoor air for free cooling, reducing the requirement for mechanical cooling
- Heavy gauge galvanized steel cabinet lined with thick fiberglass insulation
- Mixed air sensor, outdoor air sensor and 24VAC transformer furnished
- Approved for California Title 24 building standards
- ASHRAE 90.1-2010 compliant
- See separate Product Specifications bulletin for additional information and available control and sensor options

99% WINTER DESIGN TEMPERATURES FOR THE CONTIGUOUS UNITED STATES



This map is a necessarily generalized guide to temperatures in the contiguous United States. Temperatures shown for areas such as mountainous regions and large urban centers may not be accurate. The data used to develop this map was taken from the 1993 ASHRAE Fundamentals Handbook (Chapter 24, Table 1: Climate Conditions for the United States).

Reprinted with permission from NFPA 54: National Fuel Gas Code 1999, National Fire Protection Association, Quincy, MA 02269. This reprinted material is not the complete and official position of the National Fire Protection Association on the referenced subject, which is represented only by the standard in its entirety.

SPECIFICATIONS

Gas Heating Performance	Model No.	ML180UH045E36A	ML180UH070E36A	ML180UH070E36B	ML180UH090E48B
	Model No. - Low Nox	ML180UH045XE36A	ML180UH070XE36A	ML180UH070XE36B	ML180UH090XE48B
	¹ AFUE	80%	80%	80%	80%
	Input - Btuh	44,000	66,000	66,000	88,000
	Output - Btuh	36,000	53,000	53,000	72,000
	Temperature rise range - °F	15 - 45	40 - 70	40 - 70	35 - 65
	Gas Manifold Pressure (in. w.g.) Nat. Gas / LPG/Propane	3.5 / 10.0	3.5 / 10.0	3.5 / 10.0	3.5 / 10.0
High Static - in. w.g.		0.50	0.50	0.50	0.50
Connections in.	Flue connection - in. round	4	4	4	4
	Gas pipe size IPS	1/2	1/2	1/2	1/2
Indoor Blower	Wheel nom. dia. x width - in.	10 x 8	10 x 10	10 x 10	10 x 10
	Motor Type	DC Brushless	DC Brushless	DC Brushless	DC Brushless
	Motor output - hp	1/2	1/2	1/2	3/4
	Tons of add-on cooling	1.5 - 3	1.5 - 3	1.5 - 3	2.5 - 4
	Air Volume Range - cfm	350 - 1380	625 - 1435	395 - 1415	750 - 1785
Electrical Data	Voltage	120 volts - 60 hertz - 1 phase			
	Blower motor full load amps	6.8	6.8	6.8	8.4
	Maximum overcurrent protection	15	15	15	15
Shipping Data	lbs. - 1 package	111	111	127	142

SPECIFICATIONS

Gas Heating Performance	Model No.	ML180UH090E60C	ML180UH110E60C	ML180UH135E60D
	Model No. - Low Nox	---	ML180UH110XE60C	---
	¹ AFUE	80%	80%	80%
	Input - Btuh	88,000	110,000	132,000
	Output - Btuh	72,000	90,000	107,000
	Temperature rise range - °F	30 - 60	35 - 65	30 - 60
	Gas Manifold Pressure (in. w.g.) Nat. Gas / LPG/Propane	3.5 / 10.0	3.5 / 10.0	3.5 / 10.0
High Static - in. w.g.		0.50	0.50	0.50
Connections in.	Flue connection - in. round	4	4	4
	Gas pipe size IPS	1/2	1/2	1/2
Indoor Blower	Wheel nom. dia. x width - in.	11-1/2 x 10	11-1/2 x 10	11 x 11
	Motor Type	DC Brushless	DC Brushless	DC Brushless
	Motor output - hp	1	1	1
	Tons of add-on cooling	3 - 5	3 - 5	3.5 - 5
	Air Volume Range - cfm	990 - 2290	920 - 2315	1140 - 2495
Electrical Data	Voltage	120 volts - 60 hertz - 1 phase		
	Blower motor full load amps	10.9	10.9	10.9
	Maximum overcurrent protection	15	15	15
Shipping Data	lbs. - 1 package	152	160	178

NOTE - Filters and provisions for mounting are not furnished and must be field provided.

¹ Annual Fuel Utilization Efficiency based on DOE test procedures and according to FTC labeling regulations. Isolated combustion system rating for non-weatherized furnaces.

INSTALLATION CLEARANCES

UPFLOW POSITION

Vent Type	Type B1	Type C
Sides	0 (0)	¹ 0 (0)
Rear	0 (0)	0 (0)
Top	1 (25)	1 (25)
Front	2-1/4 (57)	2-1/4 (57)
Front (service/alcove)	24 (610)	24 (610)
Floor	Combustible	Combustible
Flue	1 (25)	6 (152)

NOTE - Air for combustion must conform to the methods outlined in the National Fuel Gas Code (NFPA 54/ANSI-Z223.1).

NOTE - In the U.S. flue sizing must conform to the methods outlined in the current National Fuel Gas Code (NFPA 54/ANSI-Z223.1) or applicable provisions of local building codes.

¹ Left side requires 4 in. if single wall vent is used on 14-1/2 in. cabinets, 2 in. on 17-1/2 in. cabinets.

HORIZONTAL POSITION

Vent Type	Type B1	Type C
End	¹ 2 (51)	¹ 2 (51)
Rear	0 (0)	0 (0)
Top	¹ 0 (0)	¹ 0 (0)
Front	2-1/4 (57)	2-1/4 (57)
Front (service)	24 (610)	24 (610)
Floor	Combustible	Combustible
Flue	1 (25)	6 (152)

NOTE - Air for combustion must conform to the methods outlined in the National Fuel Gas Code (NFPA 54/ANSI-Z223.1).

NOTE - In the U.S. flue sizing must conform to the methods outlined in the current National Fuel Gas Code (NFPA 54/ANSI-Z223.1) or applicable provisions of local building codes.

¹ Line contact installation permissible between jacket top or sides and building joists.

OPTIONAL ACCESSORIES - ORDER SEPARATELY

		"A" Width Models	"B" Width Models	"C" Width Models	"D" Width Models
CABINET ACCESSORIES					
Horizontal Suspension Kit - Horizontal only		51W10	51W10	51W10	51W10
Return Air Base - Upflow only		65W75	50W98	50W99	51W00
High Performance Economizer (Commercial Only)		10U53	10U53	10U53	10U53
CONTROLS					
iComfort® M30 Smart Wi-Fi Thermostat		15Z69	15Z69	15Z69	15Z69
Remote Outdoor Air Temperature Sensor		X2658	X2658	X2658	X2658
Blower Relay Kit (for two-stage outdoor units)		85W66	85W66	85W66	85W66
Furnace Twinning Kit		16W72	16W72	16W72	16W72
FILTERS					
1 Air Filter and Rack Kit	Horizontal (end)	87L95	87L96	87L97	87L98
	Size of filter - in.	14 x 25 x 1	18 x 25 x 1	20 x 25 x 1	25 x 25 x 1
	Side Return	44J22	44J22	44J22	44J22
	Single	66K63	66K63	66K63	66K63
	Ten Pack	66K63	66K63	66K63	66K63
	Size of filter - in.	16 x 25 x 1	16 x 25 x 1	16 x 25 x 1	16 x 25 x 1
NIGHT SERVICE KIT					
Night Service Kit		84W47	84W47	84W47	84W47
VENTING					
Vent Adaptor – 6 in. conn. size upflow applications only		18M79	18M79	18M79	18M79

¹ Cleanable polyurethane, frame-type filter.

GAS HEAT ACCESSORIES

Input	High Altitude Pressure Switch Kit			Natural Gas to LPG/Propane Kit		LPG/Propane to Natural Gas Kit	Natural Gas High Altitude Orifice Kit
	0 - 4500 ft.	4501 - 7500 ft.	7501 - 10,000 ft.	0 - 7500 ft.	7501 - 10,000 ft.	0 - 7500 ft.	7501 - 10,000 ft.
045	No Change	80W52	80W51	11K49	11K44	73W81	73W37
070	No Change	80W52	80W51	11K49	11K44	73W81	73W37
090	No Change	80W52	80W51	11K49	11K44	73W81	73W37
110	No Change	80W52	80W52	11K49	11K44	73W81	73W37
135	No Change	80W52	80W51	11K49	11K44	73W81	73W37

HIGH ALTITUDE DERATE

NOTE - Units may be installed at altitudes up to 2000 ft. above sea level without any modifications.

At altitudes above 2000 ft. units must be derated to match information in the shaded areas shown below.

NOTE - This is the only permissible derate for these units.

Input	Gas Manifold Pressure (Outlet) in. w.g.								Line Pressure - in. w.g.			
	0 - 2000 Feet		2001 - 4500 Feet		4501 - 7500 Feet		7501 - 10,000 ft.		Minimum		Maximum	
	Natural Gas	LPG/Propane	Natural Gas	LPG/Propane	Natural Gas	LPG/Propane	¹ Natural Gas	LPG/Propane	Natural Gas	LPG/Propane		
045	3.5	10	3.2	10	3	10	3.5	10	4.5	11	13	
070	3.5	10	3.2	10	2.8	10	3.5	10	4.5	11	13	
090	3.5	10	3.2	10	2.7	9.6	3.5	10	4.5	11	13	
110	3.5	10	3.5	10	3	9.6	3.5	10	4.5	11	13	
135	3.5	10	3.5	10	2.9	9.6	3.5	10	4.5	11	13	

¹ Natural Gas High Altitude Orifice Kit required.

DIMENSIONS - UNIT - UPFLOW POSITION

¹ NOTE - 60C and 60D size units that require air volumes over 1800 cfm must have one of the following:

1. Single side return air and Optional Return Air Base with transition that must accommodate required 20 x 25 x 1 inch (508 x 635 x 25 mm) air filter to maintain proper velocity.
 2. Bottom return air.
 3. Return air from both sides.
 4. Bottom and one side return air.
- See Blower Performance Tables for additional information.

² Flue outlet may be horizontal but furnace must be vented vertically

³ Optional External Side Return Air Filter Kit is not for use with the optional Return Air Base.

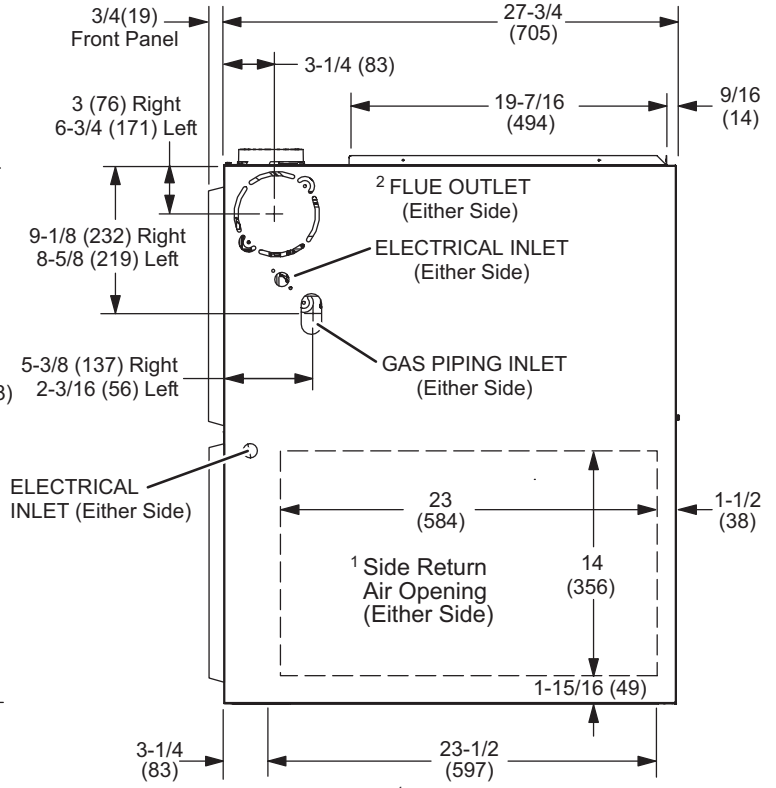
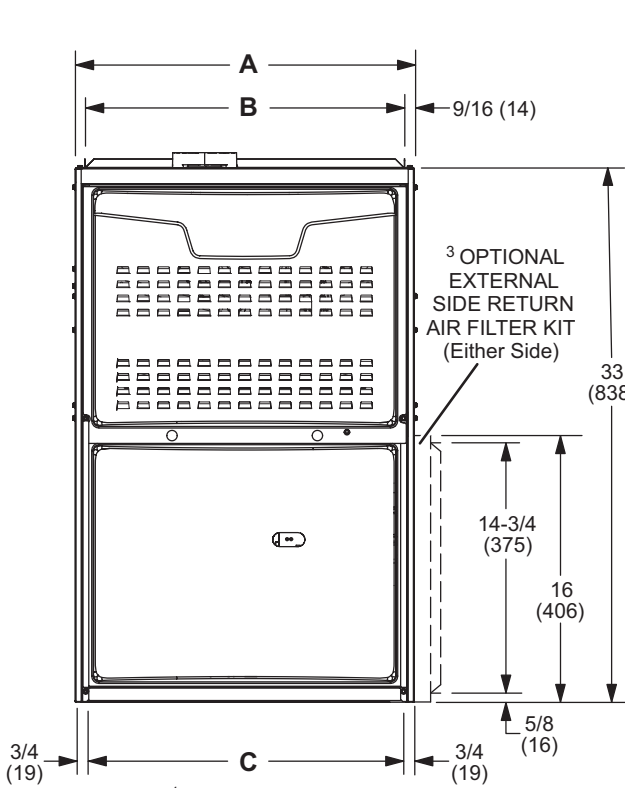
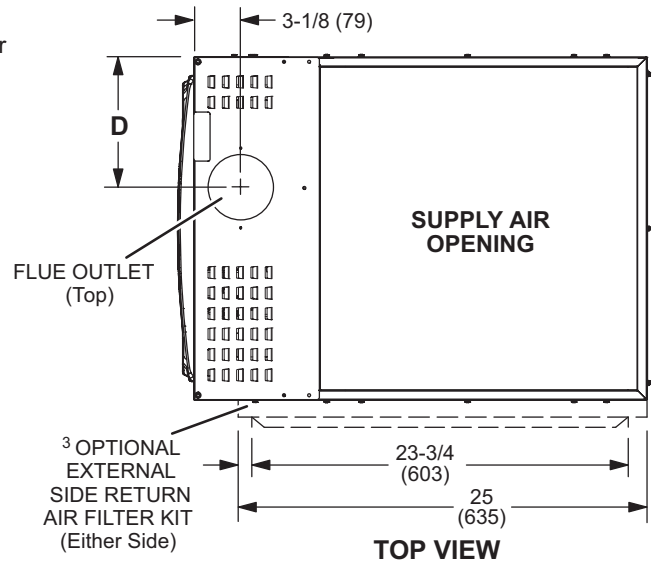

Model No.	A		B		C		D	
	in.	mm	in.	mm	in.	mm	in.	mm
ML180UH045E36A ML180UH070E36A	14-1/2	368	13-3/8	340	13	330	4-3/4	121
ML180UH070E36B ML180UH090E48B	17-1/2	446	16-3/8	416	16	406	6-1/4	159
ML180UH090E60C ML180UH110E60C	21	533	19-7/8	504	19-1/2	495	8	203
ML180UH135E60D	24-1/2	622	23-3/8	594	23	584	9-3/4	248

DIMENSIONS - UNIT - HORIZONTAL POSITION

LEFT-HAND AIR DISCHARGE

¹ Flue outlet may be from end but furnace must be vented vertically

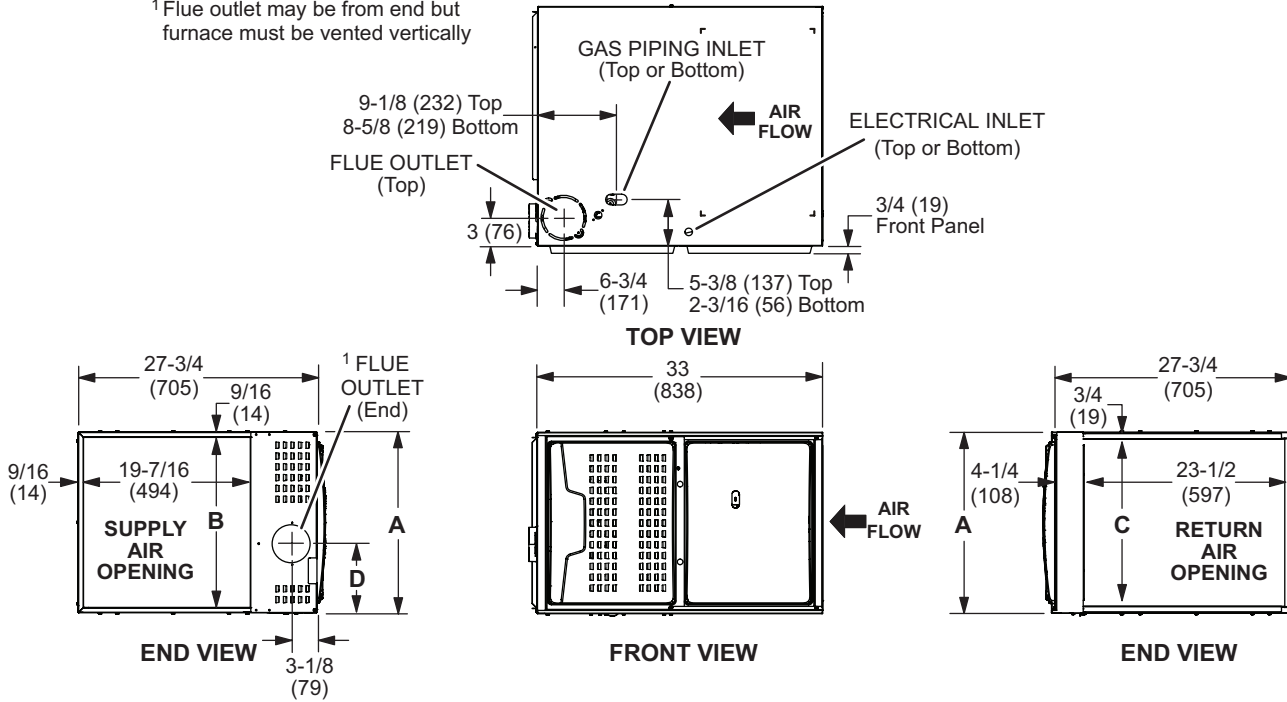

RIGHT-HAND AIR DISCHARGE

¹ Flue outlet may be horizontal but furnace must be vented vertically

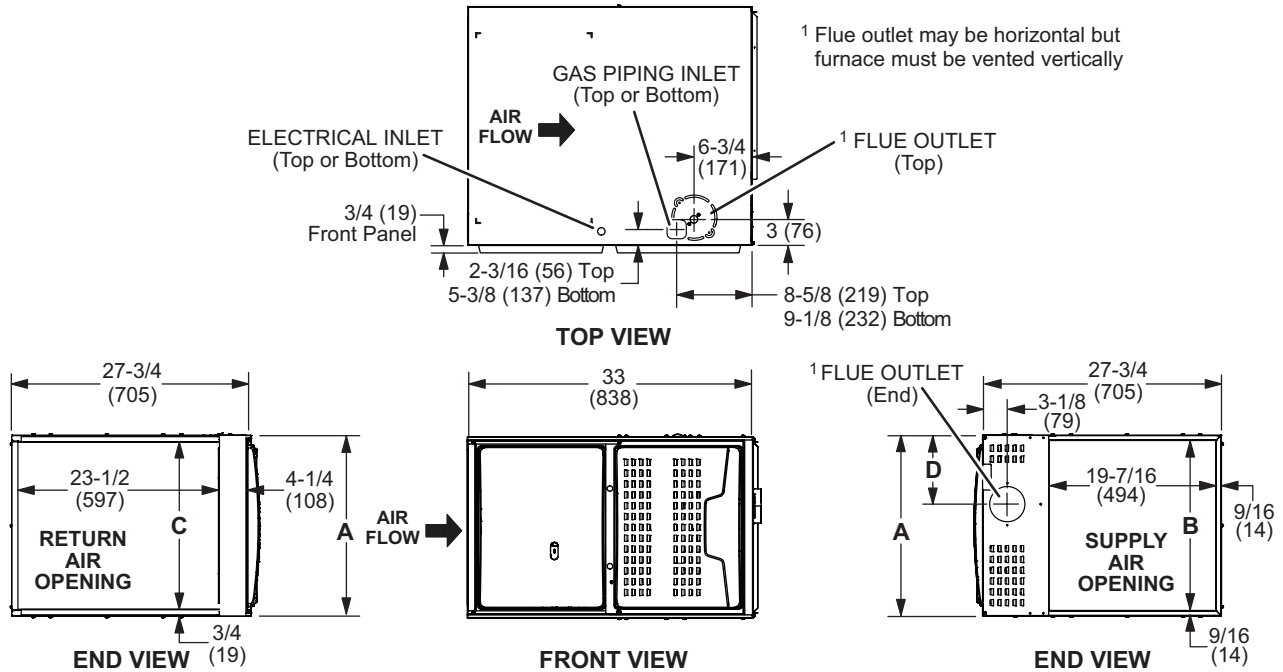

Model No.	A		B		C		D	
	in.	mm	in.	mm	in.	mm	in.	mm
ML180UH045E36A ML180UH070E36A	14-1/2	368	13-3/8	340	13	330	4-3/4	121
ML180UH070E36B ML180UH090E48B	17-1/2	446	16-3/8	416	16	406	6-1/4	159
ML180UH090E60C ML180UH110E60C	21	533	19-7/8	504	19-1/2	495	8	203
ML180UH135E60D	24-1/2	622	23-3/8	594	23	584	9-3/4	248

DIMENSIONS - OPTIONAL ACCESSORIES

HORIZONTAL (END) FILTER KIT

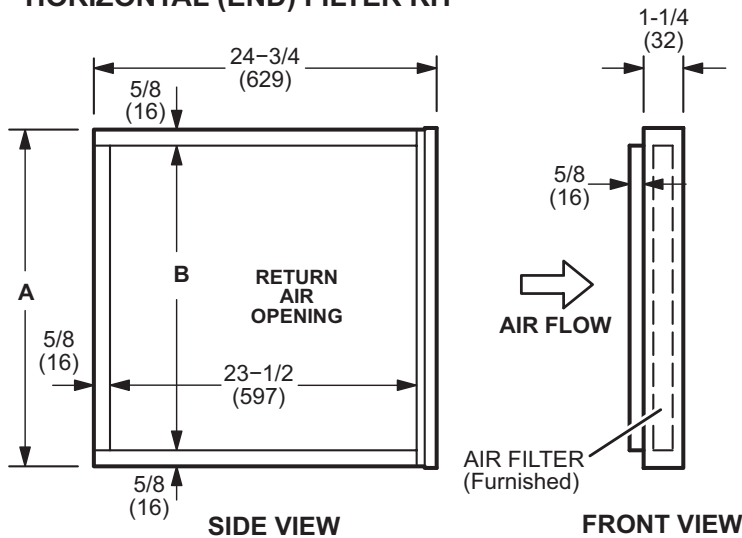

Furnace Cabinet Width	Catalog Number	A		B	
		in.	mm	in.	mm
A	87L95	14	356	12-3/4	324
B	87L96	18	457	16-3/4	425
C	87L97	21	533	18-3/4	476
D	87L98	25	635	23-3/4	603

Optional Return Air Base (Upflow Applications Only - For use with A, B, C and D cabinets)

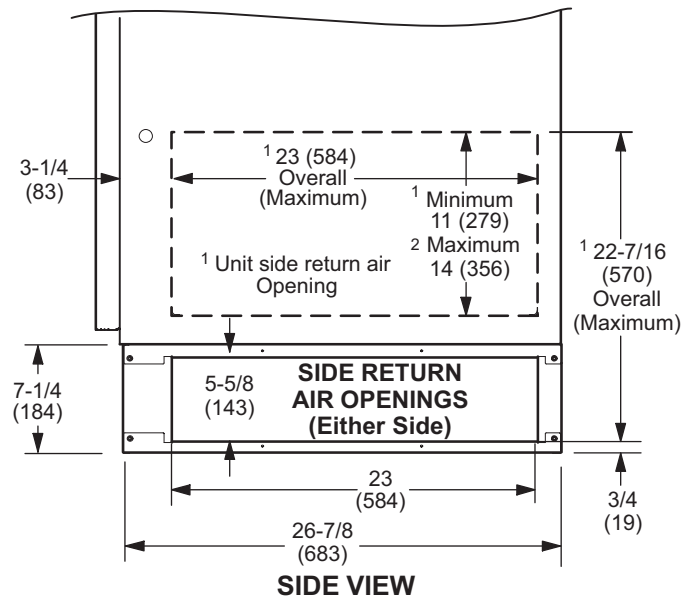
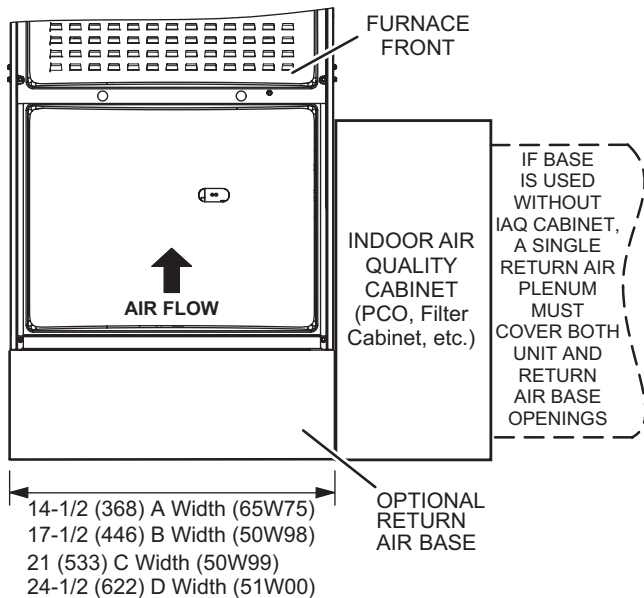

NOTE- Optional Side Return Air Filter Kits are not for use with Optional Return Air Base.

- ¹ Both the unit return air opening and the base return air opening must be covered by a single plenum or IAQ cabinet. Minimum unit side return air opening dimensions for units requiring 1800 cfm or more of air (W x H): 23 x 11 in. (584 x 279 mm). The opening can be cut as needed to accommodate plenum or IAQ cabinet while maintaining dimensions shown. Side return air openings must be cut in the field. There are cutting guides stenciled on the cabinet for the side return air opening. The size of the opening must not extend beyond the markings on the furnace cabinet.
- ² To minimize pressure drop, the largest opening height possible, up to 14 in. (356 mm), is preferred.

DIMENSIONS - FURNACE/COIL COMBINED DIMENSIONS

UPFLOW POSITION

Model No			C35/C37/CX35/CX38 Cased				C35 Uncased			
			A		B		A		B	
C35/CX35	C37	CX38	in.	mm	in.	mm	in.	mm	in.	mm
C35/CX35-18/24A C35/CX35-18/24B	---	---	16-1/2	419	49-1/2	1257	14-1/8	359	47-1/8	1197
C35/CX35-24A C35/CX35-24B	C37-25A C37-25B	CX38-25A CX38-25B	18-1/2	470	51-1/2	1308	16-3/8	416	49-3/8	1254
---	---	CX38-30A	20-1/2	521	53-1/2	1359	---	---	---	---
C35/CX35-30A C35/CX35-30B	C37-31A C37-31B	CX38-31A CX38-31B	22-1/2	572	55-1/2	1410	20-3/4	527	53-3/4	1365
C35/CX35-30/36A C35/CX35-30/36B C35/CX35-30/36C	C37-36A C37-36B C37-36C	CX38-36A CX38-36B CX38-36C	24-1/2	622	57-1/2	1461	22-1/4	565	55-1/4	1403
C35/CX35-36A C35/CX35-36B	C37-38A C37-38B	CX38-38A CX38-38B	24-1/2	622	57-1/2	1461	22-3/8	568	55-3/8	1407
---	C37-42B	CX38-42B	24-1/2	622	57-1/2	1461	---	---	---	---
C35/CX35-48B C35/CX35-48C	C37-43B C37-43C	CX38-43B CX38-43C	27-1/2	699	60-1/2	1537	26-1/4	667	59-1/4	1505
---	C37-48B C37-48C	CX38-44/48B CX38-44/48C	24-1/2	622	57-1/2	1461	---	---	---	---
C35/CX35-49C	C37-49C	CX38-49C	29-1/2	749	62-1/2	1588	28-1/2	724	61-1/2	1562
C35/CX35-50/60C	C37-50/60C	CX38-50/60C	27-1/2	699	60-1/2	1537	25-7/8	657	58-7/8	1495
---	C37-60D	CX38-60D	25-1/2	648	58-1/2	1486	---	---	---	---
CX35-60C	C37-62C	CX38-62C	31-1/2	800	64-1/2	1638	30-5/8	778	63-5/8	1616
CX35-60D	C37-62D	CX38-62D	29-1/2	749	62-1/2	1588	28	711	61	1549

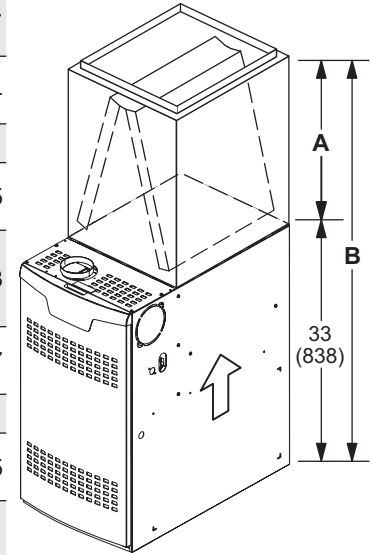

HORIZONTAL POSITION

Model No.	A		B	
	in.	mm	in.	mm
CH33				
CH33-18A	21-1/2	546	54-1/2	1384
CH33-24/30A, CH33-36A, CH33-36B, CH33-36C,	26-1/2	673	59-1/2	1511
CH33-44/48B, CH33-50/60C,	31-1/2	800	64-1/2	1638
CH35				
CH35-18A, CH35-24A, CH35-24B, CH35-30B,	26-1/2	673	59-1/2	1511
CH35-30A, CH35-42B, CH35-48B,	31-1/2	880	64-1/2	1638
CHX35				
CHX35-18A, CHX35-24A, CHX35-24B, CHX35-30B,	26-1/2	673	59-1/2	1511
CHX35-30A, CHX35-42B, CHX35-48B,	31-1/2	880	64-1/2	1638

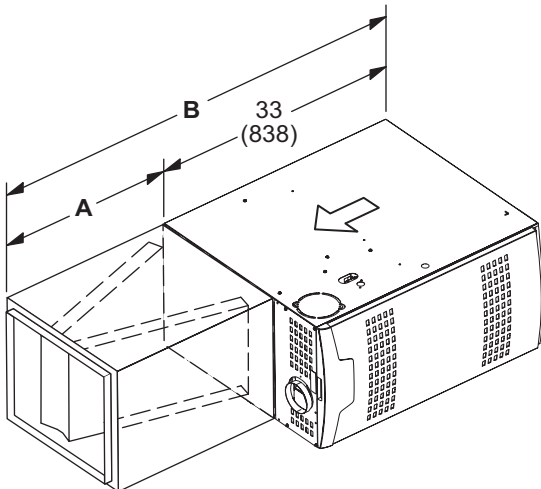

BLOWER DATA

ML180UH045E36A PERFORMANCE (Less Filter)

External Static Pressure in. w.g.	Air Volume / Watts at Various Blower Speeds									
	High		Medium-High		Medium		Medium-Low		Low	
	cfm	Watts	cfm	Watts	cfm	Watts	cfm	Watts	cfm	Watts
0.00	1380	265	1155	165	995	120	975	115	945	105
0.10	1345	270	1120	175	950	120	880	105	865	100
0.20	1320	285	1080	190	900	125	805	105	700	85
0.30	1290	295	1055	200	875	135	750	110	640	90
0.40	1265	310	1010	205	825	145	710	120	595	95
0.50	1230	315	990	215	790	155	660	125	535	100
0.60	1190	330	945	230	750	165	630	135	500	110
0.70	1165	340	915	235	705	170	570	140	435	115
0.80	1130	350	880	245	670	180	535	150	380	120

ML180UH070E36A PERFORMANCE (Less Filter)

External Static Pressure in. w.g.	Air Volume / Watts at Various Blower Speeds									
	High		Medium-High		Medium		Medium-Low		Low	
	cfm	Watts	cfm	Watts	cfm	Watts	cfm	Watts	cfm	Watts
0.00	---	---	---	---	---	---	---	---	---	---
0.10	1435	282	1215	178	1120	147	1095	133	930	88
0.20	1400	290	1170	187	1090	154	1050	141	875	98
0.30	1365	303	1145	198	1055	164	1025	153	845	102
0.40	1335	311	1105	206	1015	172	985	160	795	110
0.50	1310	325	1075	216	980	177	945	169	760	117
0.60	1285	341	1040	224	950	187	905	175	705	125
0.70	1250	344	1010	235	905	196	865	183	665	129
0.80	1215	354	975	244	860	204	830	191	625	136

ML180UH070E36B PERFORMANCE (Less Filter)

External Static Pressure in. w.g.	Air Volume / Watts at Various Blower Speeds									
	High		Medium-High		Medium		Medium-Low		Low	
	cfm	Watts	cfm	Watts	cfm	Watts	cfm	Watts	cfm	Watts
0.00	---	---	---	---	---	---	---	---	---	---
0.10	1415	280	1295	170	1145	145	1130	130	955	95
0.20	1355	290	1225	185	1110	150	1080	140	885	100
0.30	1330	300	1190	200	1060	160	1035	155	825	110
0.40	1290	310	1155	205	1015	175	970	160	770	120
0.50	1245	325	1115	215	980	180	930	170	695	125
0.60	1225	335	1045	230	920	190	865	180	625	135
0.70	1190	350	1000	235	855	205	790	190	540	140
0.80	1160	365	925	245	790	205	735	200	445	145

ML180UH090E48B PERFORMANCE (Less Filter)

External Static Pressure in. w.g.	Air Volume / Watts at Various Blower Speeds									
	High		Medium-High		Medium		Medium-Low		Low	
	cfm	Watts	cfm	Watts	cfm	Watts	cfm	Watts	cfm	Watts
0.00	1785	380	1570	270	1440	220	1395	190	1190	120
0.10	1755	395	1535	275	1420	230	1350	205	1140	130
0.20	1730	415	1505	290	1380	245	1310	215	1110	145
0.30	1690	435	1460	305	1345	260	1275	230	1065	155
0.40	1645	440	1435	320	1310	270	1240	240	1010	165
0.50	1615	455	1395	335	1265	285	1180	255	955	180
0.60	1590	470	1350	350	1210	290	1150	265	915	185
0.70	1545	475	1300	360	1175	305	1095	275	860	200
0.80	N/A	N/A	1270	370	1140	310	1040	285	820	210

BLOWER DATA

ML180UH090E60C PERFORMANCE (Less Filter)

External Static Pressure in. w.g.	Air Volume / Watts at Different Blower Speeds																			
	Bottom Return Air, Side Return Air from Both Sides or Return Air from Bottom and One Side.										Single Side Return Air – Air volumes in bold require Optional return Air Base and field fabricated transition to accommodate 20 x 25 x 1 in. air filter in order to maintain proper air velocity.									
	High		Med-High		Medium		Med-Low		Low		High		Med-High		Medium		Med-Low		Low	
	cfm	Watts	cfm	Watts	cfm	Watts	cfm	Watts	cfm	Watts	cfm	Watts	cfm	Watts	cfm	Watts	cfm	Watts	cfm	Watts
0.00	2255	640	1940	420	1750	310	1580	230	1485	185	2290	655	1980	425	1775	310	1605	235	1495	195
0.10	2200	655	1910	440	1705	315	1535	240	1385	190	2250	675	1945	445	1730	320	1555	245	1400	190
0.20	2150	675	1865	450	1655	340	1490	260	1340	205	2210	695	1885	465	1680	340	1510	265	1350	205
0.30	2125	695	1835	475	1635	355	1450	275	1285	215	2165	715	1850	475	1645	355	1470	275	1285	215
0.40	2090	715	1800	495	1585	370	1405	285	1235	230	2135	720	1810	490	1595	370	1410	290	1225	230
0.50	2060	735	1760	510	1545	385	1370	305	1200	245	2070	735	1765	515	1545	390	1370	305	1180	245
0.60	2020	750	1725	525	1515	405	1320	320	1145	255	2030	760	1715	530	1495	405	1325	320	1140	255
0.70	1980	765	1680	540	1465	420	1265	330	1105	270	1990	775	1685	540	1450	425	1265	330	1095	270
0.80	1935	785	1635	560	1420	435	1225	350	1055	285	1950	795	1645	560	1415	435	1225	345	1040	285

ML180UH110E60C PERFORMANCE (Less Filter)

External Static Pressure in. w.g.	Air Volume / Watts at Different Blower Speeds																			
	Bottom Return Air, Side Return Air with Return Air from Both Sides or Return Air from Bottom and One Side.										Single Side Return Air – Air volumes in bold require Optional return Air Base and field fabricated transition to accommodate 20 x 25 x 1 in. air filter in order to maintain proper air velocity.									
	High		Med-High		Medium		Med-Low		Low		High		Med-High		Medium		Med-Low		Low	
	cfm	Watts	cfm	Watts	cfm	Watts	cfm	Watts	cfm	Watts	cfm	Watts	cfm	Watts	cfm	Watts	cfm	Watts	cfm	Watts
0.00	2230	635	1945	430	1715	295	1555	230	1470	185	2315	645	1990	415	1780	300	1610	230	1510	200
0.10	2180	655	1905	445	1690	305	1510	240	1340	175	2260	655	1945	425	1740	315	1550	240	1400	185
0.20	2135	680	1865	465	1630	330	1470	260	1280	190	2210	680	1895	450	1680	335	1510	255	1350	200
0.30	2090	695	1830	480	1595	345	1440	275	1235	200	2165	700	1850	465	1650	355	1455	275	1285	210
0.40	2050	715	1785	495	1550	360	1385	285	1175	210	2130	715	1830	485	1585	365	1395	285	1230	225
0.50	2025	730	1740	520	1500	375	1340	300	1130	225	2095	730	1770	500	1535	385	1365	300	1175	235
0.60	2010	750	1710	535	1470	390	1305	320	1080	240	2055	755	1725	515	1495	400	1305	315	1135	250
0.70	1965	755	1670	555	1420	410	1255	330	1015	255	2000	765	1675	535	1465	410	1255	325	1080	265
0.80	1905	785	1635	560	1380	425	1215	350	975	270	1965	785	1640	555	1400	425	1210	345	1025	275

ML180UH135E60D PERFORMANCE (Less Filter)

External Static Pressure in. w.g.	Air Volume / Watts at Different Blower Speeds																			
	Bottom Return Air, Side Return Air with Return Air from Both Sides or Return Air from Bottom and One Side.										Single Side Return Air – Air volumes in bold require Optional return Air Base and field fabricated transition to accommodate 20 x 25 x 1 in. air filter in order to maintain proper air velocity.									
	High		Med-High		Medium		Med-Low		Low		High		Med-High		Medium		Med-Low		Low	
	cfm	Watts	cfm	Watts	cfm	Watts	cfm	Watts	cfm	Watts	cfm	Watts	cfm	Watts	cfm	Watts	cfm	Watts	cfm	Watts
0.00	2495	755	2295	590	2045	435	1845	315	1650	230	2365	725	2295	575	2005	410	1820	300	1635	235
0.10	2440	780	2220	620	2015	445	1820	330	1615	245	2350	745	2210	595	2000	435	1745	320	1530	230
0.20	2390	790	2175	640	1935	470	1735	350	1550	255	2330	775	2175	625	1945	455	1730	330	1490	250
0.30	2360	805	2140	655	1895	490	1720	370	1485	275	2245	785	2135	645	1895	475	1655	355	1425	265
0.40	2285	835	2125	675	1850	510	1660	380	1455	290	2215	810	2085	660	1840	495	1600	375	1385	285
0.50	2240	860	2060	690	1815	535	1610	400	1415	310	2175	825	2045	680	1815	505	1590	390	1340	290
0.60	2225	865	2015	715	1785	550	1535	420	1330	320	2125	845	1995	700	1765	530	1525	405	1300	310
0.70	2160	895	1955	735	1755	570	1500	440	1265	340	2095	865	1950	710	1700	545	1485	420	1260	325
0.80	2105	905	1925	750	1715	580	1435	450	1215	345	2065	880	1890	725	1680	565	1415	445	1205	345

REVISIONS

Sections	Description of Change
Document	Specifications, ratings, blower and dimensions added for models - ML180UH070E36A, ML180UH070XE36A.



Visit us at www.lennox.com
For the latest technical information, www.LennoxPros.com
Contact us at 1-800-4-LENNOX

NOTE - Due to Lennox' ongoing commitment to quality, Specifications, Ratings and Dimensions subject to change without notice and without incurring liability.
Improper installation, adjustment, alteration, service or maintenance can cause property damage or personal injury.
Installation and service must be performed by a qualified installer and servicing agency.

©2019 Lennox Industries, Inc.