



GAS FURNACES

**ML180UHV**

MERIT® SERIES

Upflow / Horizontal - Variable Speed Blower - 60Hz

Bulletin No. 210882

September 2019

**RESIDENTIAL  
PRODUCT SPECIFICATIONS**



**AFUE - 80%**  
**Input - 30,000 to 110,000 Btuh**  
**Nominal Add-on Cooling - 1.5 to 5 Tons**

**MODEL NUMBER IDENTIFICATION**

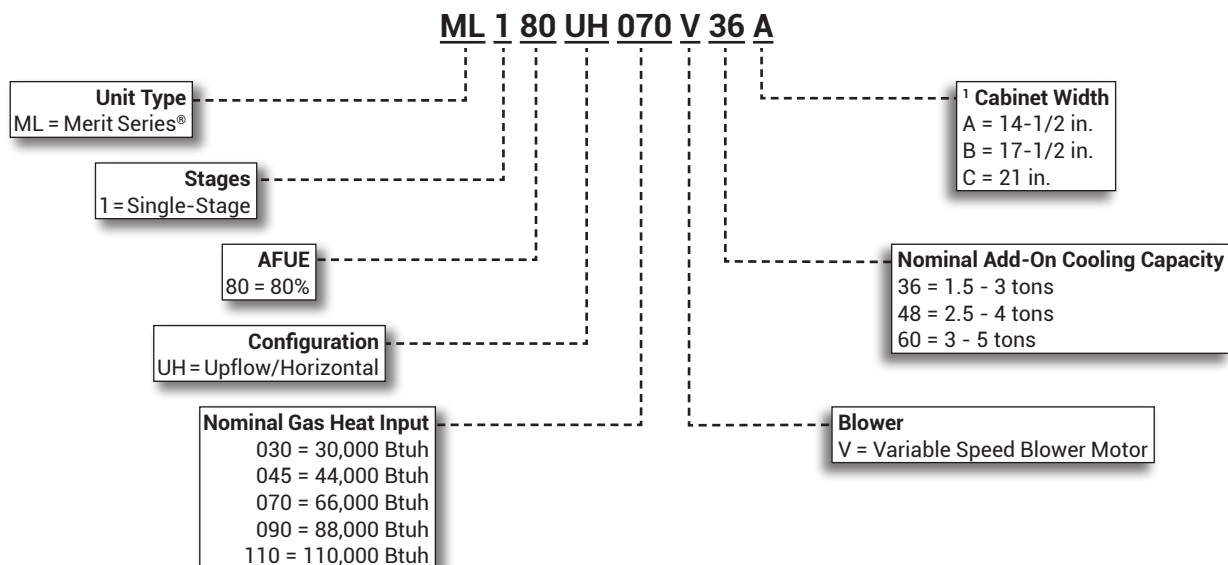

<sup>1</sup> Indoor coils with the same letter designation physically matches the furnace.

## FEATURE HIGHLIGHTS

1. Lennox Duralok™ Heat Exchanger Assembly
2. Inshot Burners
3. SureLight® Hot Surface Ignitor
4. Gas Control Valve
5. Combustion Air Inducer
6. Flame Rollout Switches
7. Variable Speed Direct Drive Blower
8. SureLight® Integrated Furnace Control
9. Insulated Cabinet
10. Safety Interlock Switch
11. Gas Piping And Electrical Inlets

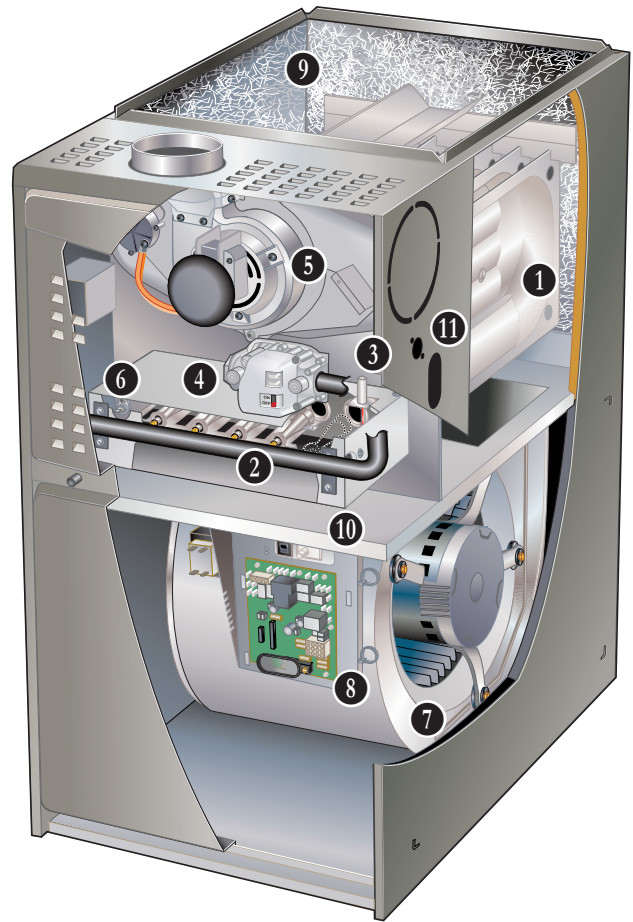

**NOTE - ML180V FURNACES ARE NOT AVAILABLE IN CANADA!**  
**NOTE - ML180V FURNACES CANNOT BE TWINNED!**  
**NOTE - ML180V FURNACES ARE NOT AVAILABLE WITH LOW NOX!**

## CONTENTS

Approvals and Warranty . . . . .	3
Blower Data . . . . .	16
Dimensions - Furnace/Coil Combined Dimensions . . . . .	15
Dimensions - Optional Accessories. . . . .	14
Dimensions - Unit - Horizontal Position . . . . .	13
Dimensions - Unit - Upflow Position . . . . .	12
Features . . . . .	3
Gas Heat Accessories . . . . .	11
High Altitude Derate . . . . .	11
Installation Clearances. . . . .	11
Optional Accessories - Order Separately . . . . .	10
Specifications . . . . .	9

## APPROVALS AND WARRANTY

### APPROVALS

- AHRI Certified
- Tested and rated according to US DOE test procedures and FTC labeling regulations
- ISO 9001 Registered Manufacturing Quality System
- Blower data from unit tests conducted in Lennox Laboratory air test chamber

### WARRANTY

- Heat Exchanger:
  - Limited twenty years in residential applications
  - Limited ten years in non-residential applications
- All other covered components:
  - Limited five years in residential installations
  - Limited one year in non-residential installations

**NOTE** - Refer to Lennox Equipment Limited Warranty certificate included with unit for specific details.

## FEATURES

### APPLICATIONS

- Input capacities - 30,000, 44,000, 66,000 88,000 and 110,000 Btuh
- Energy efficiency (AFUE) - 80%
- Compact cabinet
- Upflow, horizontal-left or horizontal-right applications
- Lennox add-on indoor coils, high-efficiency air cleaners and humidifiers can easily be added to furnace
- Shipped factory assembled with all controls installed and wired
- Ready for installation in upflow or horizontal right-hand position without any modifications

**NOTE** - Horizontal left-hand position requires repositioning of pressure switch.

- Removable bottom seal panel shipped in place for side return air is easily removed for bottom/end return air applications
- Each unit factory test operated to ensure proper operation

### ZONING APPLICATIONS

- Units may be used with certain zoning systems
- Zone control panel must be able to interface and communicate with the variable speed blower motor in the unit
- Harmony III™ Zoning System has this capability

### HEATING SYSTEM

- 1 **Lennox Duralok™ Heat Exchanger Assembly**
  - Heavy gauge aluminized steel heat exchanger
  - Crimped seam clamshell design
  - Designed for normal expansion and contraction
  - Minimum resistance to air flow
  - Laboratory life cycle tested in excess of industry standards
  - Compact size permits low overall design of furnace cabinet

- 2 **Inshot Burners**

- Aluminized steel inshot burners provide efficient, trouble-free operation
- Burner venturi mixes air and gas in correct proportion for proper combustion
- Burner assembly is removable from the unit as a single component for ease of service

- 3 **SureLight® Hot Surface Ignitor**

- Tough, reliable, long-life, trouble-free performance
- Silicon nitride ignitor
- Cemented to steatite block for protection against current leakage
- Ignition leads are constructed of nickel plated copper and are enclosed in high temperature Teflon® insulation for dependable operation

- 4 **Gas Control Valve**

- 24 volt redundant combination gas control valve combines manual shut off switch (On-Off), automatic electric valve (dual) and gas pressure regulation into a compact combination control

- 5 **Combustion Air Inducer**

- Shaded pole heavy duty blower prepurges heat exchanger and safely vents flue products
- Pressure switch proves blower operation before allowing gas valve to open
- Operates only during heating cycle
- Direct access allows inducer assembly to be rotated 90° clockwise or counterclockwise to facilitate easy vent attachment from either side of the cabinet in upflow applications and from the top in horizontal applications

## FEATURES

### HEATING SYSTEM (continued)

#### 6 Flame Rollout Switches (2)

- Factory installed on the front of the burner box
- Switches provides protection from abnormal operating conditions
- Manual reset

#### Limit Control

- Primary limit is accurately located on vestibule panel on all units
- Automatic reset

### Optional Accessories

#### High Altitude Pressure Switch Kit

- Required on most units for proper unit operation at altitudes from 4,501 to 7500 ft.

#### Natural Gas to LPG/Propane Conversion Kit

- Required for field changeover from natural gas to LPG/Propane

#### LPG/Propane to Natural Gas Conversion Kit

- Required for field changeover from LPG/Propane to natural gas

#### Vent Adaptor (Upflow Applications Only)

- Allows venting through a masonry chimney without the need of a flue liner
- Manual reset temperature sensor protects against abnormal operating conditions
- Sensor wiring may be routed from either side of adaptor
- Minimum winter design temperatures:
  - -10°F when used with interior masonry chimneys
  - +5°F when used with exterior masonry chimneys

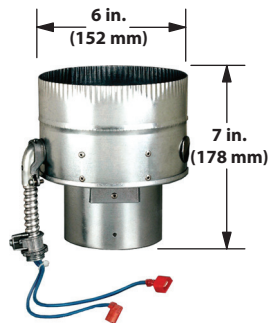

**NOTE** - Refer to Winter Design Temperatures Map on page 8 for application information. Also refer to the installation instructions for detailed information.

### BLOWER

#### 7 Variable Speed Direct Drive Blower

- Each blower assembly statically and dynamically balanced
- Blower assembly easily removed for servicing

#### Variable Speed Blower Motor

- Variable speed motor maintains specified air volume from 0 through 0.80 in. w.g. (heating) and 0 through 1.0 in. w.g. (Cooling) static range
- Variable speed operation is achieved by the use of an ECM (Electronically Commutated Motor) motor
- Motor is controlled by furnace control
- Change in blower speed is easily accomplished by simple DIP switch change on the furnace control
- During start-up the blower motor slowly ramps up to normal operating speed to minimize noise and increases comfort
- At the end of a cooling or heating cycle, the motor slowly ramps down after a short blower "off" delay
- If continuous blower operation has been selected, the variable speed motor will slowly ramp down until it reaches the airflow for that condition
- Motor is resiliently mounted
- See Blower Data tables

**NOTE** - When furnaces are used with the Harmony III™ Zoning System, blower motor operates from predetermined minimum - maximum air volumes to satisfy zone requirements.

## FEATURES

### CONTROLS

- 8 SureLight® Integrated Furnace Control**
- Contains all necessary controls and relays to operate furnace
  - Combustion air inducer is operated by the integrated furnace control.
    - Prior to ignition, a low speed pre-purge cycle for 15 seconds is initiated
    - After the main burners are turned off, a post-purge cycle for 5 seconds is run
  - Flame sensor utilizes flame rectification for safe and reliable operation
  - Should flame fail to ignite, control will initiate 5 re-attempts at ignition before locking out unit operation for 60 minutes
  - Watchguard type circuit automatically resets ignition controls after one hour of continuous thermostat demand after unit lockout, eliminating nuisance calls for service
  - Two LED's indicate unit status and aid in troubleshooting:
    1. CFM LED (green) - Indicates blower cfm
    2. STATUS LED (red) - Flashes diagnostic codes
  - Two terminals are furnished for additional power supply requirements for 120 volt (less than 1 amp) powered IAQ accessories
  - Blower speed - for second stage cool four air volume selections are selected by DIP switches on control
  - Cool speed can be adjusted to correct optional cooling capacity
  - See Blower Performance tables
  - First stage blower speed is a percentage of second stage speed
  - ADJUST DIP switch allows normal (NORM), 10% higher (+ plus) or 10% lower (- minus) motor speed selection within the HEAT and COOL speeds selected for fine tuning air volume
  - Controls humidity by controlling blower and compressor speed on two-stage outdoor units when used with Lennox iComfort® M30 Smart Wi-Fi Thermostat or separate humidity control

### Passive Dehumidification

- For situations where humidity control is a desired, a passived dehumidification feature is built into the variable speed motor
- Motor runs at 82% for 7-1/2 minutes and then at 100% (if needed) until demand is satisfied. Once demand is met, motor ramps down to 82% for one minute before shut off

### Active or Humiditrol® Dehumidification

- A jumper on the control must be clipped to enable active dehumidification and/or operation with a Humiditrol® Whole-Home Dehumidification System
- A humidity controlling thermostat or separate humidity control is also required
  - During a call for cooling, air volume is automatically reduced, forcing humidity removal by the air conditioner or heat pump system
  - After the humidity has reached the desired set-point the cooling air volume returns to its designed rate
  - A dehumidification signal from the thermostat reduces the cooling cfm to 70% of the requested cooling cfm
- In heat mode, blower on time is fixed at 30 seconds (non-adjustable), blower off time is adjustable via DIP switches on the furnace control
- For air-conditioning applications, blower on time is 2 seconds (non-adjustable) following thermostat demand for cooling
- Control is factory installed in the unit control box.

### 24 Volt Transformer

- Furnished and factory installed on outside of control box
- 40VA transformer has fuse wired in series

### Field Wiring Make-Up Box

- Furnished for line voltage wiring
- Factory installed internally on left side of furnace
- May be installed on right side of furnace

## FEATURES

### CONTROLS (continued)

#### Optional Accessories

#### iComfort® M30 Smart Wi-Fi Thermostat

- Wi-Fi-enabled, electronic 7-day, universal, multi-stage, programmable, touchscreen thermostat
- 4 Heat/2 Cool
- Auto-changeover
- Dual-fuel control with optional outdoor sensor
- Controls dehumidification during cooling mode and humidification during heating mode
- Offers enhanced capabilities including humidification / dehumidification / dewpoint measurement and control, Humiditol® control, and equipment maintenance reminders
- Easy to read 4.3 in. color touchscreen (measured diagonally)
- LCD display with backlight shows the current and set temperature, time, inside relative humidity, system status (operating mode and schedules) and outside temperature (optional outdoor sensor required)
- Smooth Setback Recovery starts system early to achieve setpoint at start of program period
- Compressor short-cycle protection (5 minutes)
- Up to four separate schedules are available plus Schedule IQ™
- One-Touch Away Mode - A quick and easy way to set the cooling and heating setpoints while away
- Smart Away™ - Uses geo-fencing technology to determine when the homeowner is within a predetermined distance from the home to operate the system when leaving, away and arriving
- Wi-Fi remote monitoring and adjustment through a home wireless network for desktop PCs, laptops and apps for smartphones or tablets
- Smart home automation compatible with Amazon Alexa®, Google Assistant and IFTTT

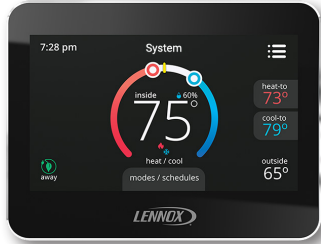

**NOTE** - See the iComfort® M30 Smart Wi-Fi Thermostat Product Specifications bulletin in the Controls section for more information.

#### Remote Outdoor Temperature Sensor

- Used with the iComfort® M30 Smart Thermostat
- Outdoor sensor allows thermostat to display outdoor temperature

**NOTE** - Sensor is required for the Enhanced Dehumidification Accessory (EDA).



#### Thermostat

- Thermostat is not furnished with unit
- Lennox Price Book for selection

#### Night Service Kit

- Contains most commonly used service parts:
  - Furnace Control
  - Ignitor
  - Flame Sensor
  - Gas Valve
  - Transformer

#### **FILTER (not furnished)**

- Filter and provisions for external mounting must be field provided

#### Optional Accessories

#### Air Filter and Rack Kit for Horizontal Return Air (End) Applications

- Washable or vacuum cleanable polyurethane frame type filter and external end return air rack
- Rack has filter door for servicing
- Flanges on rack for duct connection
- Field installed
- See dimension drawing

#### Air Filter and Rack Kit for Upflow Side Return Air

**NOTE** - Not for use with Return Air Base

- Washable or vacuum cleanable polyurethane frame type filter and external side return air rack available for field installation
- Available in single and ten pack kits
- Rack has filter door for servicing
- Flanges on rack for duct connection
- Field installs on either side of unit cabinet
- See dimension drawing

## FEATURES

### **CABINET**

- Low-profile, narrow width allows easy installation
- Heavy-gauge, cold rolled steel construction
- Pre-painted finish
- Flue outlet on top for upflow applications
- Flue outlet can be relocated to either side of cabinet for horizontal applications
- Flanges provided on supply air opening for ease of plenum connection or alignment with indoor coil
- 9 • Insulated with foil faced insulation on sides and back of heating compartment
- Complete service access
- 10 • Safety interlock switch automatically shuts off power to unit if blower compartment access panel is removed
- 11 • Gas piping and electrical inlets are provided on both sides

#### **Bottom/Side Return Air Entry:**

- Upflow/horizontal with bottom return air entry:
  - Remove furnished bottom seal panel from cabinet
- Upflow only with side return-air entry:
  - Corners are marked on either side of cabinet for return air cut-out
- See dimension drawings

**NOTE** - 60C size units that require air volumes over 1800 cfm must have one of the following:

- Single side return air and Optional Return Air Base with transition that must accommodate required 20 x 25 x 1 inch air filter to maintain proper velocity
- Bottom return air
- Return air from both sides
- Bottom and one side return air
- See Blower Performance Tables for additional information.

#### **Coil Match-Up**

- All furnaces exactly match Lennox cased upflow indoor coils and horizontal indoor coils with same letter designation (A, B, C, D) in model number
- No adaptor required
- Engaging holes furnished on cabinet for alignment
- Lennox uncased coils match furnaces without any overhang but require an optional adaptor base or field fabricated transition to match furnace opening
- See coil bulletin for additional information

#### **Low Leakage Cabinet**

- All models have less than 2% air leakage
- Meets ANSI/ASHRAE Standard 193-2010 "Method of Test for Determining the Air Tightness of HVAC Equipment"

### **Optional Accessories**

#### **Horizontal Suspension Kit**

- Provides suspension of unit and indoor coil in horizontal applications
- Allows complete service access
- Consists of corner mounted hanging brackets with vibration isolators, return air end support rail and hardware for assembly
- Metal hanging straps must be field provided

#### **Return Air Base**

**NOTE** - On furnaces with side return air, a field fabricated transition or Return Air Base is required when using an IAQ product higher than 14-3/16 in. installed next to the unit and serviced from the front. IAQ products higher than 20 in. require a field fabricated transition.

**NOTE** - Must be used for 60C size models with air volumes over 1800 cfm in upflow applications when only one side return is required.

- Cabinet is shipped flat for easy field assembly
- Pre-painted steel to match the furnace
- See Dimension Drawing

#### **High Performance Economizer (Commercial Applications Only)**

- Designed for applications requiring outdoor air to be utilized in a commercial HVAC system
- Allows the entry of fresh outdoor air for free cooling, reducing the requirement for mechanical cooling
- Heavy gauge galvanized steel cabinet
- Lined with thick fiberglass insulation
- Mixed air sensor, outdoor air sensor and 24VAC transformer furnished
- Approved for California Title 24 building standards
- ASHRAE 90.1-2010 compliant

**NOTE** - See separate Product Specifications bulletin for additional information and available control and sensor options.

## 99% WINTER DESIGN TEMPERATURES FOR THE CONTIGUOUS UNITED STATES



This map is a necessarily generalized guide to temperatures in the contiguous United States. Temperatures shown for areas such as mountainous regions and large urban centers may not be accurate. The data used to develop this map was taken from the 1993 ASHRAE Fundamentals Handbook (Chapter 24, Table 1: Climate Conditions for the United States).

Reprinted with permission from NFPA 54: National Fuel Gas Code 1999, National Fire Protection Association, Quincy, MA 02269. This reprinted material is not the complete and official position of the National Fire Protection Association on the referenced subject, which is represented only by the standard in its entirety.



## SPECIFICATIONS

Gas Heating Performance	Model No.	ML180UH030V36A	ML180UH045V36A	ML180UH070V36A	ML180UH070V36B
	<sup>1</sup> AFUE	80%	80%	80%	80%
	Input - Btuh	30,000	44,000	66,000	66,000
	Output - Btuh	24,430	36,100	53,400	53,400
	Temperature rise range - °F	25 - 55	15 - 45	30 - 60	30 - 60
	Gas Manifold Pressure (in. w.g.) Nat. Gas / LPG/Propane	3.5 / 10.0	3.5 / 10.0	3.5 / 10.0	3.5 / 10.0
<b>High Static - in. w.g.</b>		0.80	0.80	0.80	0.80
<b>Connections in.</b>	Flue connection - in. round	4	4	4	4
	Gas pipe size IPS	1/2	1/2	1/2	1/2
<b>Indoor Blower</b>	Wheel nom. dia. x width - in.	10 x 7	10 x 7	10 x 7	10 x 8
	Motor output - hp	1/2	1/2	1/2	1/2
	Tons of add-on cooling	1.5 - 3	1.5 - 3	1.5 - 3	1.5 - 3
	Air Volume Range - cfm	380 - 1320	380 - 1320	400 - 1345	370 - 1290
<b>Electrical Data</b>	Voltage	120 volts - 60 hertz - 1 phase			
	Blower motor full load amps	7.7	7.7	7.7	7.7
	Maximum overcurrent protection	15	15	15	15
<b>Shipping Data</b>	lbs. - 1 package	111	111	126	127

NOTE - Filters and provisions for mounting are not furnished and must be field provided.

<sup>1</sup> Annual Fuel Utilization Efficiency based on DOE test procedures and according to FTC labeling regulations. Isolated combustion system rating for non-weatherized furnaces.

## SPECIFICATIONS

Gas Heating Performance	Model No.	ML180UH070V48B	ML180UH090V48B	ML180UH110V60C
	<sup>1</sup> AFUE	80%	80%	80%
	Input - Btuh	66,000	88,000	110,000
	Output - Btuh	53,400	71,500	89,700
	Temperature rise range - °F	30 - 60	35 - 65	35 - 65
	Gas Manifold Pressure (in. w.g.) Nat. Gas / LPG/Propane	3.5 / 10.0	3.5 / 10.0	3.5 / 10.0
<b>High Static - in. w.g.</b>		0.50	0.50	0.50
<b>Connections in.</b>	Flue connection - in. round	4	4	4
	Gas pipe size IPS	1/2	1/2	1/2
<b>Indoor Blower</b>	Wheel nom. dia. x width - in.	11-1/2 x 9	11-1/2 x 9	11-1/2 x 10
	Motor output - hp	3/4	3/4	1
	Tons of add-on cooling	2.5 - 4	2.5 - 4	3 - 5
	Air Volume Range - cfm	430 - 1850	650 - 1740	930 - 2180
<b>Electrical Data</b>	Voltage	120 volts - 60 hertz - 1 phase		
	Blower motor full load amps	8.5	8.5	11.5
	Maximum overcurrent protection	15	15	20
<b>Shipping Data</b>	lbs. - 1 package	129	141	160

NOTE - Filters and provisions for mounting are not furnished and must be field provided.

<sup>1</sup> Annual Fuel Utilization Efficiency based on DOE test procedures and according to FTC labeling regulations. Isolated combustion system rating for non-weatherized furnaces.

## OPTIONAL ACCESSORIES - ORDER SEPARATELY

		"A" Width Models	"B" Width Models	"C" Width Models	
<b>CABINET ACCESSORIES</b>					
Horizontal Suspension Kit - Horizontal only		51W10	51W10	51W10	
Return Air Base - Upflow only		65W75	50W98	50W99	
High Performance Economizer (Commercial Only)		10U53	10U53	10U53	
<b>CONTROLS</b>					
iComfort® M30 Smart Wi-Fi Thermostat		15Z69	15Z69	15Z69	
Outdoor Temperature Sensor		X2658	X2658	X2658	
<b>FILTERS</b>					
<sup>1</sup> Air Filter and Rack Kit	Horizontal (end)	87L95	87L96	87L97	
	Size of filter - in.	14 x 25 x 1	18 x 25 x 1	20 x 25 x 1	
	Side Return	Single	44J22	44J22	44J22
		Ten Pack	66K63	66K63	66K63
	Size of filter - in.	16 x 25 x 1	16 x 25 x 1	16 x 25 x 1	
<b>NIGHT SERVICE KITS</b>					
Night Service Kit		19H89	19H89	19H89	
<b>VENTING</b>					
Vent Adaptor – 6 in. conn. size upflow applications only		18M79	18M79	18M79	

<sup>1</sup> Cleanable polyurethane, frame-type filter.

## GAS HEAT ACCESSORIES

Input	High Altitude Pressure Switch Kit			Natural Gas to LPG/Propane Kit		LPG/Propane to Natural Gas Kit	Natural Gas High Altitude Orifice Kit
	0 - 4500 ft.	4501 - 7500 ft.	7501 - 10,000 ft.	0 - 7500 ft.	7501 - 10,000 ft.	0 - 7500 ft.	7501 - 10,000 ft.
030	No Change	80W52	80W51	19D59	19H30	N/A	14C90
045	No Change	80W52	80W51	19D58	19H29	77W09	73W37
070	No Change	80W52	80W51	19D58	19H29	77W09	73W37
090	No Change	80W52	80W51	19D58	19H29	77W09	73W37
110	No Change	80W57	80W52	19D58	19H29	77W09	73W37

## HIGH ALTITUDE DERATE

NOTE - Units may be installed at altitudes up to 2000 ft. above sea level without any modifications.

At altitudes above 2000 ft. units must be derated to match information in the shaded areas shown below.

NOTE - This is the only permissible derate for these units.

Input	Gas Manifold Pressure (Outlet) in. w.g.								Line Pressure - in. w.g.		
	0 - 2000 Feet		2001 - 4500 Feet		4501 - 7500 Feet		7501 - 10,000 ft.		Minimum		Maximum
	Natural Gas	LPG/Propane	Natural Gas	LPG/Propane	Natural Gas	LPG/Propane	<sup>1</sup> Natural Gas	LPG/Propane	Natural Gas	LPG/Propane	
030	3.5	10	3.2	10	3	10	3.5	10	4.5	11	13
045	3.5	10	3.2	10	3	10	3.5	10	4.5	11	13
070	3.5	10	3.2	10	2.8	10	3.5	10	4.5	11	13
090	3.5	10	3.2	10	2.7	9.6	3.5	10	4.5	11	13
110	3.5	10	3.2	10	2.7	9.6	3.5	10	4.5	11	13

<sup>1</sup> Natural Gas High Altitude Orifice Kit required.

## INSTALLATION CLEARANCES

### UPFLOW POSITION

Vent Type	Type B1	Type C
Sides	0 (0)	<sup>1</sup> 0 (0)
Rear	0 (0)	0 (0)
Top	1 (25)	1 (25)
Front	2-1/4 (57)	2-1/4 (57)
Front (service/alcove)	24 (610)	24 (610)
Floor	Combustible	Combustible
Flue	1 (25)	6 (152)

NOTE - Air for combustion must conform to the methods outlined in the National Fuel Gas Code (NFPA 54/ANSI-Z223.1).

NOTE - In the U.S. flue sizing must conform to the methods outlined in the current National Fuel Gas Code (NFPA 54/ANSI-Z223.1) or applicable provisions of local building codes.

<sup>1</sup> Left side requires 4 in. if single wall vent is used on 14-1/2 in. cabinets, 2 in. on 17-1/2 in. cabinets.

### HORIZONTAL POSITION

Vent Type	Type B1	Type C
End	<sup>1</sup> 2	<sup>1</sup> 2
Rear	0 (0)	0 (0)
Top	<sup>1</sup> 0 (0)	<sup>1</sup> 0 (0)
Front	2-1/4 (57)	2-1/4 (57)
Front (service)	24 (610)	24 (610)
Floor	Combustible	Combustible
Flue	1 (25)	6 (152)

NOTE - Air for combustion must conform to the methods outlined in the National Fuel Gas Code (NFPA 54/ANSI-Z223.1).

NOTE - In the U.S. flue sizing must conform to the methods outlined in the current National Fuel Gas Code (NFPA 54/ANSI-Z223.1) or applicable provisions of local building codes.

<sup>1</sup> Line contact installation permissible between jacket top or sides and building joists.

## DIMENSIONS - UNIT - UPFLOW POSITION

- <sup>1</sup> NOTE - 60C size units that require air volumes over 1800 cfm must have one of the following:
1. Single side return air and Optional Return Air Base with transition that must accommodate required 20 x 25 x 1 inch (508 x 635 x 25 mm) air filter to maintain proper velocity.
  2. Bottom return air.
  3. Return air from both sides.
  4. Bottom and one side return air.
- See Blower Performance Tables for additional information.

- <sup>2</sup> Flue outlet may be horizontal but furnace must be vented vertically
- <sup>3</sup> Optional External Side Return Air Filter Kit is not for use with the optional Return Air Base.

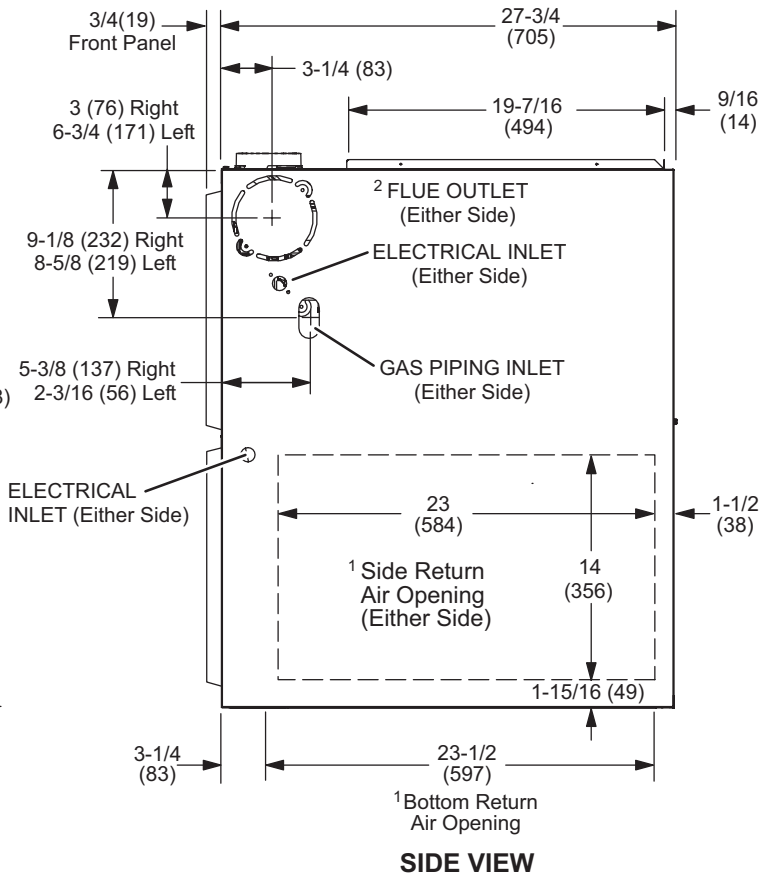
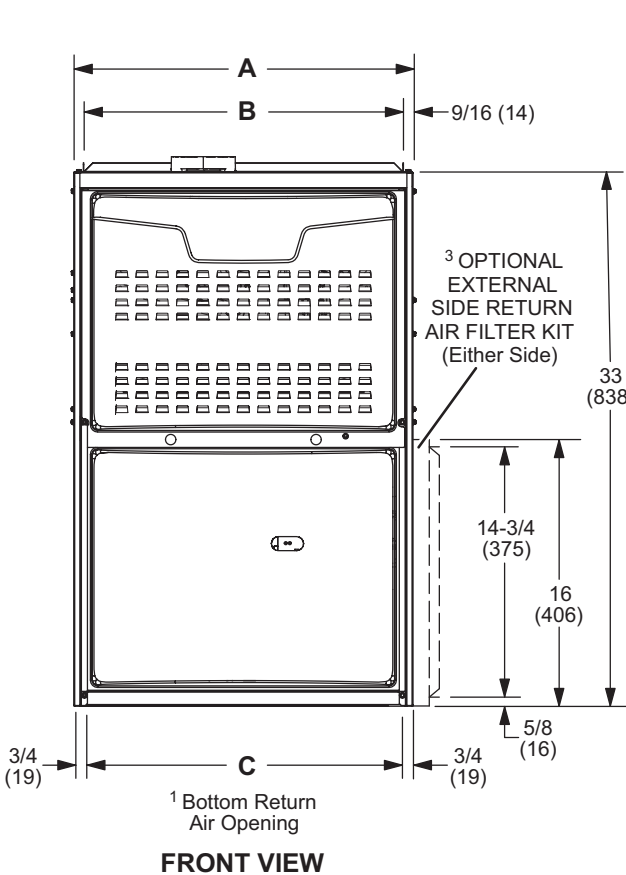
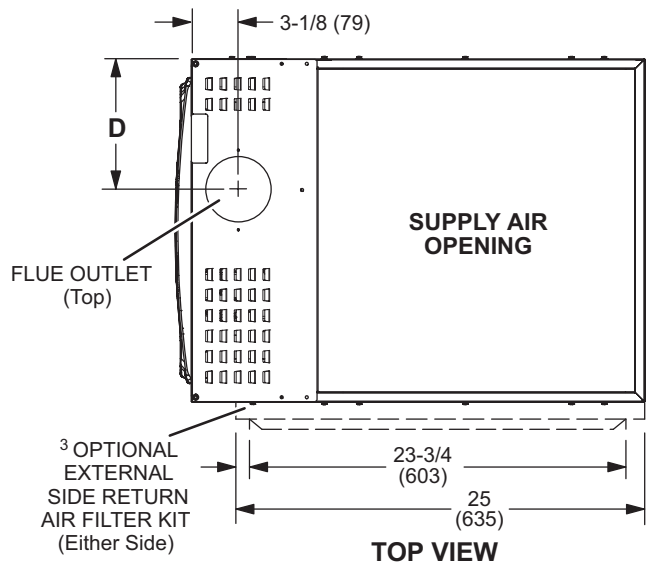

Model No.	A		B		C		D	
	in.	mm	in.	mm	in.	mm	in.	mm
ML180UH030V36A	14-1/2	368	13-3/8	340	13	330	4-3/4	121
ML180UH045V36A								
ML180UH070V36A								
ML180UH070V36B	17-1/2	446	16-3/8	416	16	406	6-1/4	159
ML180UH070V48B								
ML180UH090V48B								
ML180UH110V60C	21	533	19-7/8	504	19-1/2	495	8	203

# DIMENSIONS - UNIT - HORIZONTAL POSITION

## LEFT-HAND AIR DISCHARGE

<sup>1</sup> Flue outlet may be from end but furnace must be vented vertically

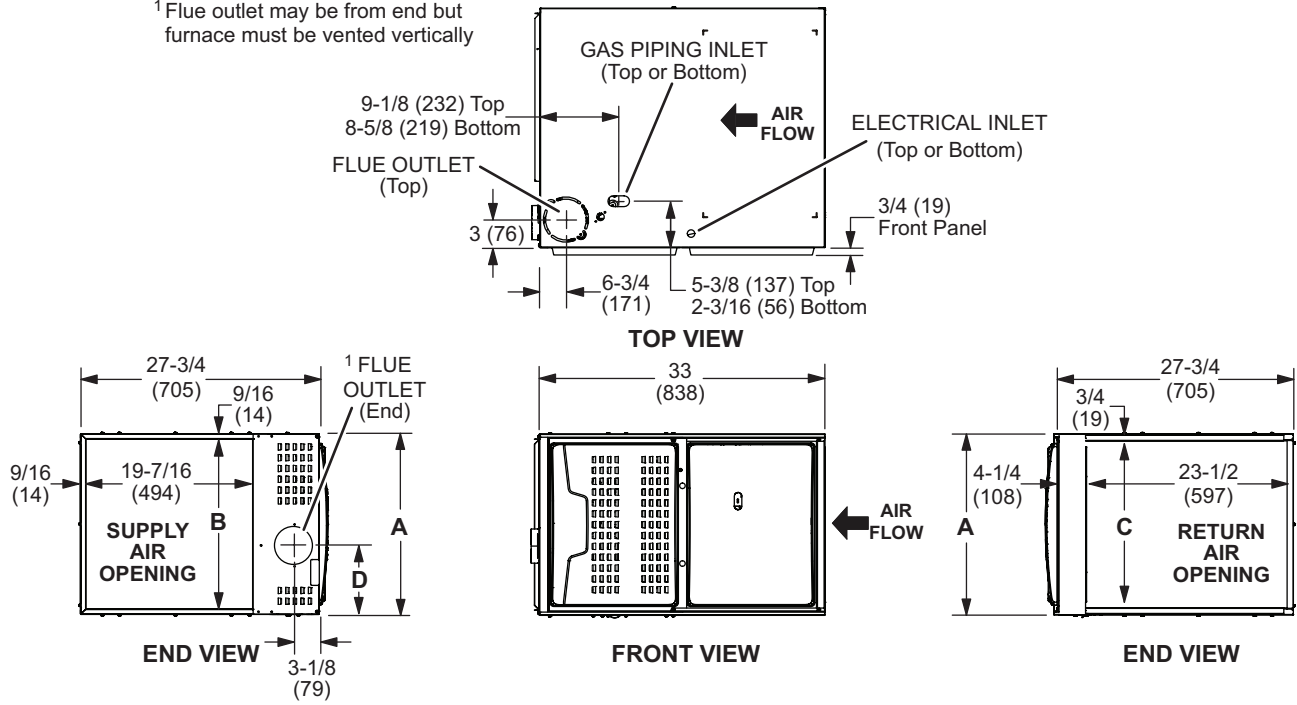

## RIGHT-HAND AIR DISCHARGE

<sup>1</sup> Flue outlet may be horizontal but furnace must be vented vertically

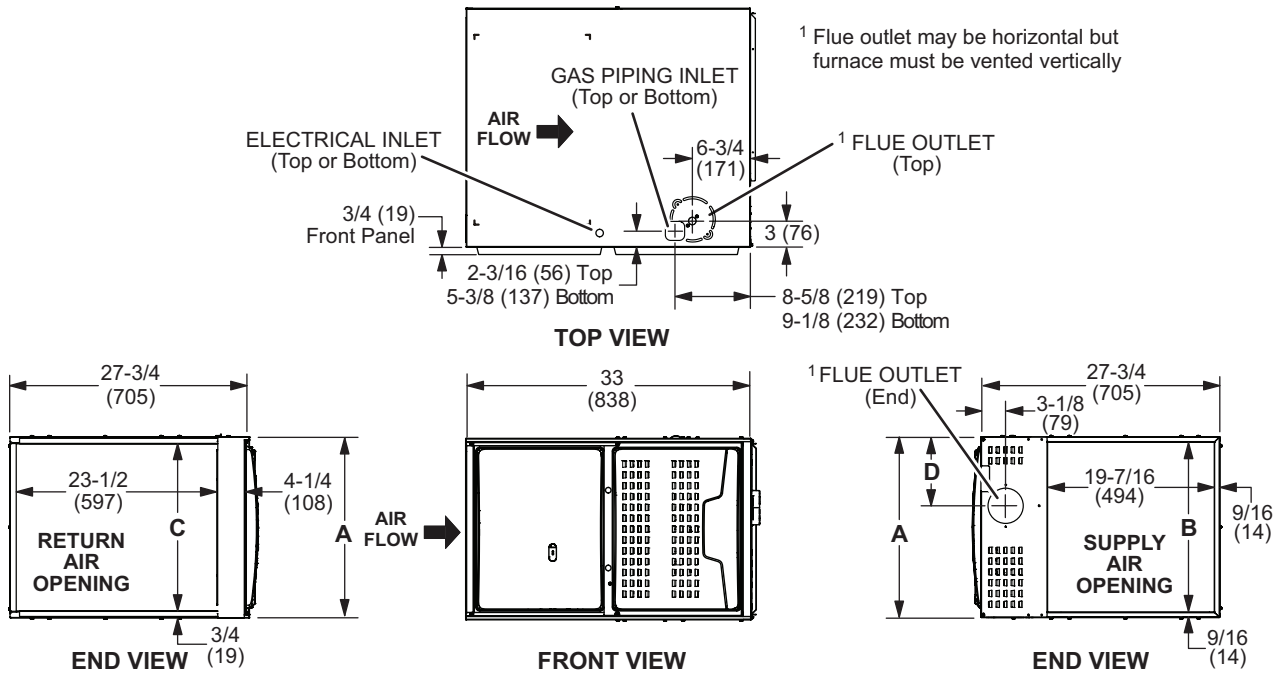

Model No.	A		B		C		D	
	in.	mm	in.	mm	in.	mm	in.	mm
ML180UH030V36A ML180UH045V36A ML180UH070V36A	14-1/2	368	13-3/8	340	13	330	4-3/4	121
ML180UH070V36B ML180UH070V48B ML180UH090V48B	17-1/2	446	16-3/8	416	16	406	6-1/4	159
ML180UH110V60C	21	533	19-7/8	504	19-1/2	495	8	203

## DIMENSIONS - OPTIONAL ACCESSORIES

### HORIZONTAL (END) FILTER KIT

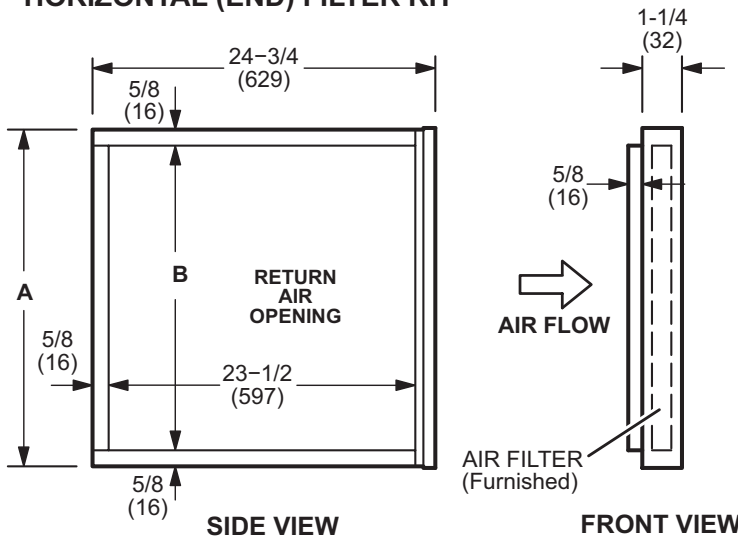

Furnace Cabinet Width	Catalog Number	A		B	
		in.	mm	in.	mm
A	87L95	14	356	12-3/4	324
B	87L96	18	457	16-3/4	425
C	87L97	21	533	18-3/4	476

### OPTIONAL RETURN AIR BASE (Upflow Applications Only - For use with A, B and C cabinets)

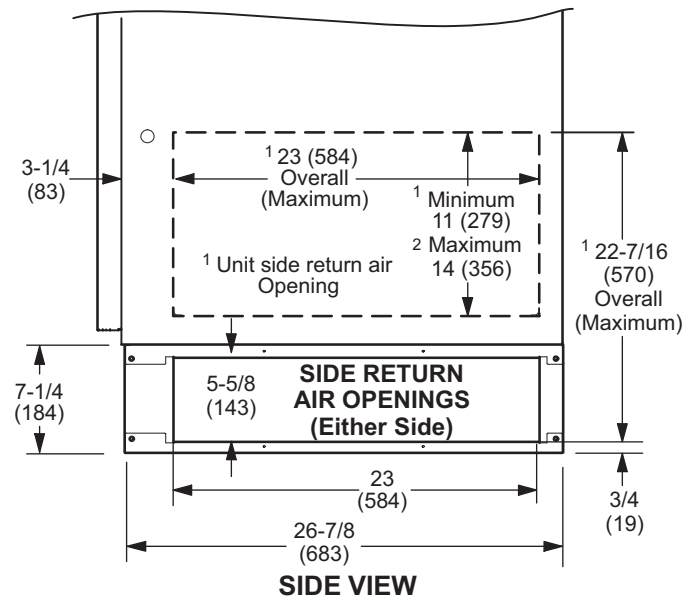
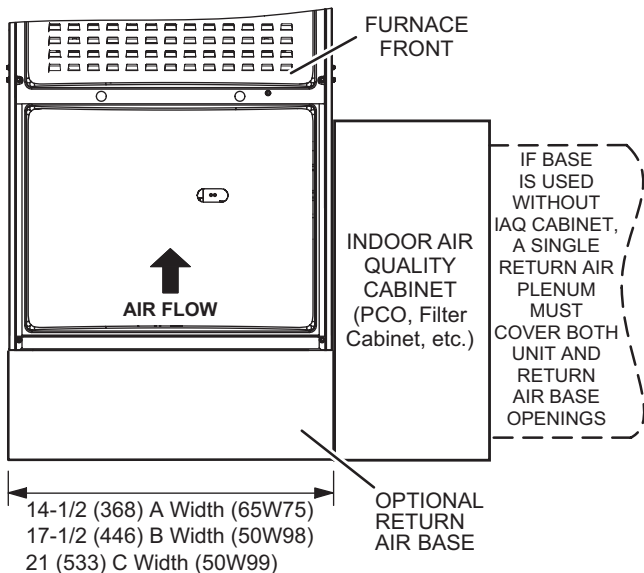

**NOTE-** Optional Side Return Air Filter Kits are not for use with Optional Return Air Base.

<sup>1</sup> Both the unit return air opening and the base return air opening must be covered by a single plenum or IAQ cabinet.

Minimum unit side return air opening dimensions for units requiring 1800 cfm or more of air (W x H): 23 x 11 in. (584 x 279 mm).

The opening can be cut as needed to accommodate plenum or IAQ cabinet while maintaining dimensions shown.

Side return air openings must be cut in the field. There are cutting guides stenciled on the cabinet for the side return air opening. The size of the opening must not extend beyond the markings on the furnace cabinet.

<sup>2</sup> To minimize pressure drop, the largest opening height possible, up to 14 in. (356 mm), is preferred.

## DIMENSIONS - FURNACE/COIL COMBINED DIMENSIONS

### UPFLOW POSITION

Model No			C35/C37/CX35/CX38 Cased				C35 Uncased			
			A		B		A		B	
C35/CX35	C37	CX38	in.	mm	in.	mm	in.	mm	in.	mm
C35/CX35-18/24A C35/CX35-18/24B	---	---	16-1/2	419	49-1/2	1257	14-1/8	359	47-1/8	1197
C35/CX35-24A C35/CX35-24B	C37-25A C37-25B	CX38-25A CX38-25B	18-1/2	470	51-1/2	1308	16-3/8	416	49-3/8	1254
---	---	CX38-30A	20-1/2	521	53-1/2	1359	---	---	---	---
C35/CX35-30A C35/CX35-30B	C37-31A C37-31B	CX38-31A CX38-31B	22-1/2	572	55-1/2	1410	20-3/4	527	53-3/4	1365
C35/CX35-30/36A C35/CX35-30/36B C35/CX35-30/36C	C37-36A C37-36B C37-36C	CX38-36A CX38-36B CX38-36C	24-1/2	622	57-1/2	1461	22-1/4	565	55-1/4	1403
C35/CX35-36A C35/CX35-36B	C37-38A C37-38B	CX38-38A CX38-38B	24-1/2	622	57-1/2	1461	22-3/8	568	55-3/8	1407
---	C37-42B	CX38-42B	24-1/2	622	57-1/2	1461	---	---	---	---
C35/CX35-48B C35/CX35-48C	C37-43B C37-43C	CX38-43B CX38-43C	27-1/2	699	60-1/2	1537	26-1/4	667	59-1/4	1505
---	C37-48B C37-48C	CX38-44/48B CX38-44/48C	24-1/2	622	57-1/2	1461	---	---	---	---
C35/CX35-49C	C37-49C	CX38-49C	29-1/2	749	62-1/2	1588	28-1/2	724	61-1/2	1562
C35/CX35-50/60C	C37-50/60C	CX38-50/60C	27-1/2	699	60-1/2	1537	25-7/8	657	58-7/8	1495
CX35-60C	C37-62C	CX38-62C	31-1/2	800	64-1/2	1638	30-5/8	778	63-5/8	1616

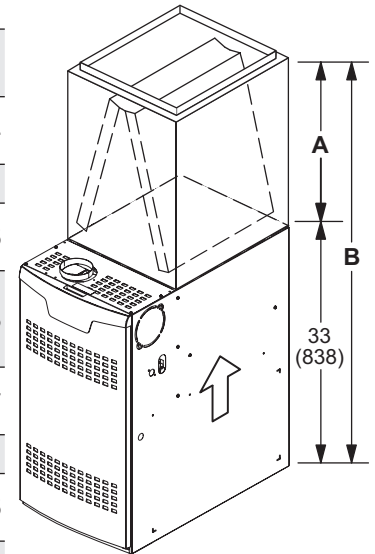

### HORIZONTAL POSITION

Model No.	A		B	
	in.	mm	in.	mm
<b>CH33</b>				
CH33-18A	21-1/2	546	54-1/2	1384
CH33-24/30A, CH33-36A, CH33-36B, CH33-36C,	26-1/2	673	59-1/2	1511
CH33-44/48B, CH33-50/60C,	31-1/2	800	64-1/2	1638
<b>CH35</b>				
CH35-18A, CH35-24A, CH35-24B, CH35-30B,	26-1/2	673	59-1/2	1511
CH35-30A, CH35-42B, CH35-48B,	31-1/2	880	64-1/2	1638
<b>CHX35</b>				
CHX35-18A, CHX35-24A, CHX35-24B, CHX35-30B,	26-1/2	673	59-1/2	1511
CHX35-30A, CHX35-42B, CHX35-48B,	31-1/2	880	64-1/2	1638

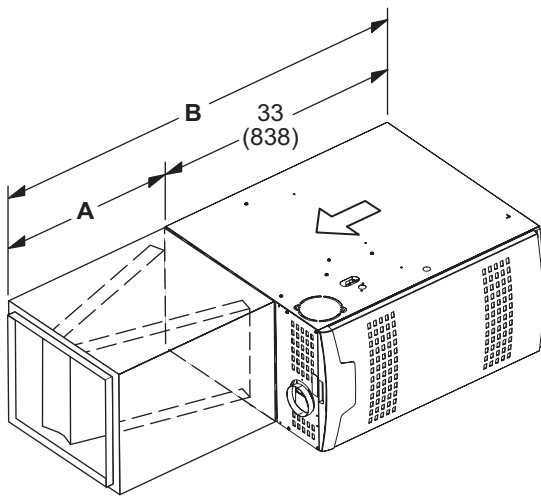

## BLOWER DATA

### ML180UH030V36A BLOWER PERFORMANCE (less filter)

#### BOTTOM RETURN AIR

0 through 0.8 in. w.g. (Heating) and 0 through 1.0 in. w.g. (Cooling) External Static Pressure Range

"ADJUST" Switch Positions	Speed Switch Positions							
	"HEAT" Speed - cfm				Second Stage "COOL" Speed - cfm			
	Low	<sup>1</sup> Med-Low	Med-Hi	High	Low	Med-Low	Med-Hi	<sup>1</sup> High
+	630	665	715	775	645	840	1045	1320
<sup>1</sup> NORM	580	615	665	715	590	765	950	1200
—	335	560	615	645	540	700	850	1070
"ADJUST" Switch Positions	First Stage "COOL" Speed - cfm							
	Low	Med-Low	Med-Hi	<sup>1</sup> High				
	+	450	580	690	860			
<sup>1</sup> NORM	410	520	635	785				
—	380	480	590	705				

<sup>1</sup> Factory default DIP switch setting.

NOTES - The effect of static pressure is included in air volumes shown.

First stage COOL (two-stage air conditioning units only) is approximately 70% of the same second stage COOL speed position.

Continuous Fan Only speed is approximately 38% of the same second stage COOL speed position - minimum 350 cfm.

Lennox Harmony III™ Zoning System Applications - Minimum blower speed is 350 cfm.

### ML180UH030V36A BLOWER MOTOR WATTS (COOLING)

DIP Switch Speed Positions	Motor Watts @ Various External Static Pressures - in. wg.																				
	First Stage										Second Stage										
	0	0.1	0.2	0.3	0.4	0.5	0.6	0.7	0.8	0	0.1	0.2	0.3	0.4	0.5	0.6	0.7	0.8	0.9	1.0	
<b>"+" (Plus) SETTING ("Adjust" DIP Switch at "+" Setting)</b>																					
"COOL" Speed	Low	10	20	31	45	56	67	77	88	99	23	39	54	67	82	98	118	130	144	157	171
	Med Low	18	31	44	58	70	88	99	112	123	48	67	86	103	122	140	158	176	193	209	226
	Med High	28	44	59	73	89	103	122	141	153	90	114	137	160	184	208	228	251	274	297	321
	High	53	72	91	108	129	146	166	183	202	180	213	246	271	304	329	364	395	427	460	492
<b>"NORM" (Normal) SETTING ("Adjust" DIP Switch at "NORM" Setting)</b>																					
"COOL" Speed	Low	7	18	29	42	51	61	72	83	94	19	33	47	59	74	93	106	116	129	142	154
	Med Low	12	26	39	52	67	80	90	102	115	40	56	72	89	106	122	139	156	182	208	233
	Med High	22	36	51	65	79	97	112	124	138	66	88	111	131	152	171	192	212	232	251	271
	High	42	59	76	93	110	127	145	161	184	130	159	188	216	244	269	297	321	346	372	397
<b>"—" (Minus) SETTING ("Adjust" DIP Switch at "—" Setting)</b>																					
"COOL" Speed	Low	4	16	28	38	47	58	67	78	88	15	28	40	54	71	82	94	106	117	127	138
	Med Low	11	23	34	48	61	72	83	93	105	30	44	59	76	91	107	127	145	157	170	182
	Med High	16	30	44	58	71	88	100	112	124	53	70	88	107	125	144	162	182	202	221	241
	High	31	47	62	77	93	109	128	150	162	98	122	146	169	194	215	239	262	285	307	330



## BLOWER DATA

### ML180UH030V36A BLOWER PERFORMANCE (less filter)

#### SINGLE SIDE RETURN AIR

0 through 0.8 in. w.g. (Heating) and 0 through 1.0 in. w.g. (Cooling) External Static Pressure Range

"ADJUST" Switch Positions	Speed Switch Positions							
	"HEAT" Speed - cfm				Second Stage "COOL" Speed - cfm			
	Low	<sup>1</sup> Med-Low	Med-Hi	High	Low	Med-Low	Med-Hi	<sup>1</sup> High
+	615	650	700	760	635	830	1025	1285
<sup>1</sup> NORM	570	600	650	700	585	755	925	1170
—	525	550	600	630	540	690	845	1050
"ADJUST" Switch Positions	First Stage "COOL" Speed - cfm							
	Low	Med-Low	Med-Hi	<sup>1</sup> High				
	+	440	570	670	850			
<sup>1</sup> NORM	415	530	610	765				
—	380	485	575	695				

<sup>1</sup> Factory default DIP switch setting.

NOTES - The effect of static pressure is included in air volumes shown.

First stage COOL (two-stage air conditioning units only) is approximately 70% of the same second stage COOL speed position.

Continuous Fan Only speed is approximately 38% of the same second stage COOL speed position - minimum 350 cfm.

Lennox Harmony III™ Zoning System Applications - Minimum blower speed is 350 cfm.

### ML180UH030V36A BLOWER MOTOR WATTS (COOLING)

DIP Switch Speed Positions	Motor Watts @ Various External Static Pressures - in. wg.																				
	First Stage										Second Stage										
	0	0.1	0.2	0.3	0.4	0.5	0.6	0.7	0.8	0	0.1	0.2	0.3	0.4	0.5	0.6	0.7	0.8	0.9	1.0	
<b>"+" (Plus) SETTING ("Adjust" DIP Switch at "+" Setting)</b>																					
"COOL" Speed	Low	8	19	30	42	55	64	76	87	99	21	36	52	65	79	95	108	125	141	157	172
	Med Low	15	29	42	54	68	82	96	109	122	42	63	84	101	120	137	154	173	193	212	232
	Med High	23	39	55	70	85	99	115	129	147	82	106	129	154	180	200	222	247	265	282	300
	High	49	67	85	105	123	142	158	177	194	173	201	229	264	296	322	353	388	418	448	478
<b>"NORM" (Normal) SETTING ("Adjust" DIP Switch at "NORM" Setting)</b>																					
"COOL" Speed	Low	5	16	28	39	50	61	71	82	91	18	31	45	58	72	86	101	116	129	143	157
	Med Low	10	24	38	50	63	76	89	101	114	32	51	70	86	103	120	135	152	170	187	205
	Med High	21	34	48	62	75	89	105	119	134	62	84	106	127	149	167	189	208	227	245	264
	High	35	53	72	89	106	123	138	156	173	121	150	180	208	235	259	290	317	340	363	386
<b>"—" (Minus) SETTING ("Adjust" DIP Switch at "—" Setting)</b>																					
"COOL" Speed	Low	4	15	26	37	47	57	67	77	86	13	26	40	52	64	79	92	105	117	129	142
	Med Low	7	20	33	45	58	69	81	94	104	27	42	57	74	88	103	120	135	154	173	192
	Med High	15	29	42	54	68	82	96	109	122	47	67	87	104	122	141	158	178	195	213	230
	High	28	43	58	74	89	103	121	137	153	87	113	139	162	188	209	232	254	279	303	327

## BLOWER DATA

### ML180UH045V36A BLOWER PERFORMANCE (less filter)

#### BOTTOM RETURN AIR

0 through 0.8 in. w.g. (Heating) and 0 through 1.0 in. w.g. (Cooling) External Static Pressure Range

"ADJUST" Switch Positions	Speed Switch Positions							
	"HEAT" Speed - cfm				Second Stage "COOL" Speed - cfm			
	Low	<sup>1</sup> Med-Low	Med-Hi	High	Low	Med-Low	Med-Hi	<sup>1</sup> High
+	900	1005	1100	1260	645	840	1045	1320
<sup>1</sup> NORM	825	915	1005	1135	590	765	950	1200
—	750	830	910	1020	540	700	850	1070
"ADJUST" Switch Positions	First Stage "COOL" Speed - cfm							
	Low	Med-Low	Med-Hi	<sup>1</sup> High				
	+	450	580	690	860			
<sup>1</sup> NORM	410	520	635	785				
—	380	480	590	705				

<sup>1</sup> Factory default DIP switch setting.

NOTES - The effect of static pressure is included in air volumes shown.

First stage COOL (two-stage air conditioning units only) is approximately 70% of the same second stage COOL speed position.

Continuous Fan Only speed is approximately 38% of the same second stage COOL speed position - minimum 350 cfm.

Lennox Harmony III™ Zoning System Applications - Minimum blower speed is 350 cfm.

### ML180UH045V36A BLOWER MOTOR WATTS (COOLING)

DIP Switch Speed Positions	Motor Watts @ Various External Static Pressures - in. wg.																				
	First Stage										Second Stage										
	0	0.1	0.2	0.3	0.4	0.5	0.6	0.7	0.8	0	0.1	0.2	0.3	0.4	0.5	0.6	0.7	0.8	0.9	1.0	
<b>"+" (Plus) SETTING ("Adjust" DIP Switch at "+" Setting)</b>																					
"COOL" Speed	Low	10	20	31	45	56	67	77	88	99	23	39	54	67	82	98	118	130	144	157	171
	Med Low	18	31	44	58	70	88	99	112	123	48	67	86	103	122	140	158	176	193	209	226
	Med High	28	44	59	73	89	103	122	141	153	90	114	137	160	184	208	228	251	274	297	321
	High	53	72	91	108	129	146	166	183	202	180	213	246	271	304	329	364	395	427	460	492
<b>"NORM" (Normal) SETTING ("Adjust" DIP Switch at "NORM" Setting)</b>																					
"COOL" Speed	Low	7	18	29	42	51	61	72	83	94	19	33	47	59	74	93	106	116	129	142	154
	Med Low	12	26	39	52	67	80	90	102	115	40	56	72	89	106	122	139	156	182	208	233
	Med High	22	36	51	65	79	97	112	124	138	66	88	111	131	152	171	192	212	232	251	271
	High	42	59	76	93	110	127	145	161	184	130	159	188	216	244	269	297	321	346	372	397
<b>"—" (Minus) SETTING ("Adjust" DIP Switch at "—" Setting)</b>																					
"COOL" Speed	Low	4	16	28	38	47	58	67	78	88	15	28	40	54	71	82	94	106	117	127	138
	Med Low	11	23	34	48	61	72	83	93	105	30	44	59	76	91	107	127	145	157	170	182
	Med High	16	30	44	58	71	88	100	112	124	53	70	88	107	125	144	162	182	202	221	241
	High	31	47	62	77	93	109	128	150	162	98	122	146	169	194	215	239	262	285	307	330

## BLOWER DATA

### ML180UH045V36A BLOWER PERFORMANCE (less filter)

#### SINGLE SIDE RETURN AIR

0 through 0.8 in. w.g. (Heating) and 0 through 1.0 in. w.g. (Cooling) External Static Pressure Range

"ADJUST" Switch Positions	Speed Switch Positions							
	"HEAT" Speed - cfm				Second Stage "COOL" Speed - cfm			
	Low	<sup>1</sup> Med-Low	Med-Hi	High	Low	Med-Low	Med-Hi	<sup>1</sup> High
+	880	980	1080	1225	635	830	1025	1285
<sup>1</sup> NORM	810	900	985	1105	585	755	925	1170
—	740	815	890	1005	540	690	845	1050
"ADJUST" Switch Positions	First Stage "COOL" Speed - cfm							
	Low	Med-Low	Med-Hi	<sup>1</sup> High				
	+	440	570	670	850			
<sup>1</sup> NORM	415	530	610	765				
—	380	485	575	695				

<sup>1</sup> Factory default DIP switch setting.

NOTES - The effect of static pressure is included in air volumes shown.

First stage COOL (two-stage air conditioning units only) is approximately 70% of the same second stage COOL speed position.

Continuous Fan Only speed is approximately 38% of the same second stage COOL speed position - minimum 350 cfm.

Lennox Harmony III™ Zoning System Applications - Minimum blower speed is 350 cfm.

### ML180UH045V36A BLOWER MOTOR WATTS (COOLING)

DIP Switch Speed Positions	Motor Watts @ Various External Static Pressures - in. wg.																				
	First Stage										Second Stage										
	0	0.1	0.2	0.3	0.4	0.5	0.6	0.7	0.8	0	0.1	0.2	0.3	0.4	0.5	0.6	0.7	0.8	0.9	1.0	
<b>"+" (Plus) SETTING ("Adjust" DIP Switch at "+" Setting)</b>																					
"COOL" Speed	Low	8	19	30	42	55	64	76	87	99	21	36	52	65	79	95	108	125	141	157	172
	Med Low	15	29	42	54	68	82	96	109	122	42	63	84	101	120	137	154	173	193	212	232
	Med High	23	39	55	70	85	99	115	129	147	82	106	129	154	180	200	222	247	265	282	300
	High	49	67	85	105	123	142	158	177	194	173	201	229	264	296	322	353	388	418	448	478
<b>"NORM" (Normal) SETTING ("Adjust" DIP Switch at "NORM" Setting)</b>																					
"COOL" Speed	Low	5	16	28	39	50	61	71	82	91	18	31	45	58	72	86	101	116	129	143	157
	Med Low	10	24	38	50	63	76	89	101	114	32	51	70	86	103	120	135	152	170	187	205
	Med High	21	34	48	62	75	89	105	119	134	62	84	106	127	149	167	189	208	227	245	264
	High	35	53	72	89	106	123	138	156	173	121	150	180	208	235	259	290	317	340	363	386
<b>"—" (Minus) SETTING ("Adjust" DIP Switch at "—" Setting)</b>																					
"COOL" Speed	Low	4	15	26	37	47	57	67	77	86	13	26	40	52	64	79	92	105	117	129	142
	Med Low	7	20	33	45	58	69	81	94	104	27	42	57	74	88	103	120	135	154	173	192
	Med High	15	29	42	54	68	82	96	109	122	47	67	87	104	122	141	158	178	195	213	230
	High	28	43	58	74	89	103	121	137	153	87	113	139	162	188	209	232	254	279	303	327

## BLOWER DATA

### ML180UH070V36A BLOWER PERFORMANCE (less filter)

#### BOTTOM RETURN AIR

0 through 0.8 in. w.g. (Heating) and 0 through 1.0 in. w.g. (Cooling) External Static Pressure Range

"ADJUST" Switch Positions	Speed Switch Positions							
	"HEAT" Speed - cfm				Second Stage "COOL" Speed - cfm			
	Low	<sup>1</sup> Med-Low	Med-Hi	High	Low	Med-Low	Med-Hi	<sup>1</sup> High
+	890	1035	1150	1300	660	880	1110	1345
<sup>1</sup> NORM	810	940	1045	1180	600	800	1000	1215
—	730	845	940	1060	540	720	900	1095
"ADJUST" Switch Positions	First Stage "COOL" Speed - cfm							
	Low	Med-Low	Med-Hi	<sup>1</sup> High				
	+	470	630	765	930			
<sup>1</sup> NORM	440	565	700	835				
—	395	510	630	750				

<sup>1</sup> Factory default DIP switch setting.

NOTES - The effect of static pressure is included in air volumes shown.

First stage COOL (two-stage air conditioning units only) is approximately 70% of the same second stage COOL speed position.

Continuous Fan Only speed is approximately 38% of the same second stage COOL speed position - minimum 350 cfm.

Lennox Harmony III™ Zoning System Applications - Minimum blower speed is 350 cfm.

### ML180UH070V36A BLOWER MOTOR WATTS (COOLING)

DIP Switch Speed Positions	Motor Watts @ Various External Static Pressures - in. wg.																				
	First Stage										Second Stage										
	0	0.1	0.2	0.3	0.4	0.5	0.6	0.7	0.8	0	0.1	0.2	0.3	0.4	0.5	0.6	0.7	0.8	0.9	1.0	
<b>"+" (Plus) SETTING ("Adjust" DIP Switch at "+" Setting)</b>																					
"COOL" Speed	Low	22	33	44	58	70	82	94	109	117	36	50	65	85	97	111	127	139	154	170	186
	Med Low	32	45	57	74	85	103	114	132	146	88	100	112	130	148	165	182	199	216	233	249
	Med High	59	69	79	98	113	132	147	165	177	121	153	186	207	221	242	271	290	316	343	369
	High	84	105	126	139	156	178	196	213	230	301	324	346	364	372	378	407	428	456	485	513
<b>"NORM" (Normal) SETTING ("Adjust" DIP Switch at "NORM" Setting)</b>																					
"COOL" Speed	Low	17	29	41	51	66	82	87	98	110	30	43	55	70	85	98	117	131	147	162	178
	Med Low	26	38	49	65	79	88	107	116	132	63	76	89	109	123	142	159	173	192	210	229
	Med High	41	55	70	84	100	116	133	146	159	135	145	155	163	186	212	231	249	272	294	317
	High	62	80	98	113	132	151	163	185	201	205	230	255	272	276	297	321	343	374	405	437
<b>"—" (Minus) SETTING ("Adjust" DIP Switch at "—" Setting)</b>																					
"COOL" Speed	Low	13	25	38	45	62	82	80	89	104	25	36	47	58	74	87	108	123	139	155	170
	Med Low	21	32	43	57	73	74	101	102	119	46	58	70	92	102	121	140	150	170	190	210
	Med High	28	44	62	72	89	102	120	128	143	106	111	117	128	156	186	197	215	234	253	272
	High	46	61	76	92	111	129	136	160	176	139	163	188	203	205	234	253	274	306	339	372

## BLOWER DATA

### ML180UH070V36A BLOWER PERFORMANCE (less filter)

#### SINGLE SIDE RETURN AIR

0 through 0.8 in. w.g. (Heating) and 0 through 1.0 in. w.g. (Cooling) External Static Pressure Range

"ADJUST" Switch Positions	Speed Switch Positions							
	"HEAT" Speed - cfm				Second Stage "COOL" Speed - cfm			
	Low	<sup>1</sup> Med-Low	Med-Hi	High	Low	Med-Low	Med-Hi	<sup>1</sup> High
+	890	1035	1150	1300	650	850	1070	1300
<sup>1</sup> NORM	810	940	1045	1180	600	770	975	1180
—	730	845	940	1060	540	695	875	1060
"ADJUST" Switch Positions	First Stage "COOL" Speed - cfm							
	Low	Med-Low	Med-Hi	<sup>1</sup> High				
	+	460	600	740	890			
<sup>1</sup> NORM	440	560	670	800				
—	395	505	605	720				

<sup>1</sup> Factory default DIP switch setting.

NOTES - The effect of static pressure is included in air volumes shown.

First stage COOL (two-stage air conditioning units only) is approximately 70% of the same second stage COOL speed position.

Continuous Fan Only speed is approximately 38% of the same second stage COOL speed position - minimum 350 cfm.

Lennox Harmony III™ Zoning System Applications - Minimum blower speed is 350 cfm.

### ML180UH070V36A BLOWER MOTOR WATTS (COOLING)

DIP Switch Speed Positions	Motor Watts @ Various External Static Pressures - in. wg.																				
	First Stage										Second Stage										
	0	0.1	0.2	0.3	0.4	0.5	0.6	0.7	0.8	0	0.1	0.2	0.3	0.4	0.5	0.6	0.7	0.8	0.9	1.0	
<b>"+" (Plus) SETTING ("Adjust" DIP Switch at "+" Setting)</b>																					
"COOL" Speed	Low	11	26	41	50	65	82	93	101	110	32	49	65	78	92	101	120	131	152	174	196
	Med Low	24	42	59	75	87	98	112	128	142	69	85	100	117	133	156	169	190	210	231	251
	Med High	47	63	80	93	110	130	147	162	176	147	152	157	182	208	227	258	272	301	331	360
	High	85	98	110	131	147	171	192	206	228	245	260	276	294	320	353	375	401	432	462	492
<b>"NORM" (Normal) SETTING ("Adjust" DIP Switch at "NORM" Setting)</b>																					
"COOL" Speed	Low	15	27	39	51	61	76	91	95	109	30	42	53	74	83	101	112	127	145	162	180
	Med Low	25	40	54	67	80	88	98	120	134	40	64	89	98	115	129	144	168	181	194	206
	Med High	34	50	67	82	98	114	124	146	161	106	115	124	147	174	194	216	234	256	279	301
	High	60	76	92	111	126	150	164	177	198	181	193	204	219	251	281	298	318	347	377	406
<b>"—" (Minus) SETTING ("Adjust" DIP Switch at "—" Setting)</b>																					
"COOL" Speed	Low	20	28	37	52	58	70	89	88	108	28	36	44	70	75	101	105	123	137	151	165
	Med Low	26	38	50	60	74	78	86	113	126	23	49	78	81	100	106	122	149	156	162	169
	Med High	25	40	56	72	88	100	104	131	148	77	87	98	120	145	165	181	201	218	235	252
	High	43	59	76	95	108	132	141	152	173	134	143	151	163	197	223	238	252	280	307	335

## BLOWER DATA

### ML180UH070V36B BLOWER PERFORMANCE (less filter)

#### BOTTOM RETURN AIR

0 through 0.8 in. w.g. (Heating) and 0 through 1.0 in. w.g. (Cooling) External Static Pressure Range

"ADJUST" Switch Positions	Speed Switch Positions							
	"HEAT" Speed - cfm				Second Stage "COOL" Speed - cfm			
	Low	<sup>1</sup> Med-Low	Med-Hi	High	Low	Med-Low	Med-Hi	<sup>1</sup> High
+	875	970	1075	1225	640	820	1020	1290
<sup>1</sup> NORM	800	890	975	1100	600	755	935	1170
—	725	810	885	995	540	685	835	1050
"ADJUST" Switch Positions	First Stage "COOL" Speed - cfm							
	Low	Med-Low	Med-Hi	<sup>1</sup> High				
	+	440	570	675	845			
<sup>1</sup> NORM	400	530	620	770				
—	370	480	570	695				

<sup>1</sup> Factory default DIP switch setting.

NOTES - The effect of static pressure is included in air volumes shown.

First stage COOL (two-stage air conditioning units only) is approximately 70% of the same second stage COOL speed position.

Continuous Fan Only speed is approximately 38% of the same second stage COOL speed position - minimum 350 cfm.

Lennox Harmony III™ Zoning System Applications - Minimum blower speed is 350 cfm.

### ML180UH070V36B BLOWER MOTOR WATTS (COOLING)

DIP Switch Speed Positions	Motor Watts @ Various External Static Pressures - in. wg.																				
	First Stage										Second Stage										
	0	0.1	0.2	0.3	0.4	0.5	0.6	0.7	0.8	0	0.1	0.2	0.3	0.4	0.5	0.6	0.7	0.8	0.9	1.0	
<b>"+" (Plus) SETTING ("Adjust" DIP Switch at "+" Setting)</b>																					
"COOL" Speed	Low	7	19	31	45	55	65	76	96	96	22	37	52	66	82	96	113	127	140	154	168
	Med Low	17	30	43	55	71	84	99	110	122	43	63	84	99	117	137	155	172	192	212	231
	Med High	24	40	57	71	86	103	119	136	151	79	102	125	150	172	195	216	240	259	278	297
	High	48	67	86	104	123	141	159	178	196	162	192	222	254	282	311	346	369	401	433	464
<b>"NORM" (Normal) SETTING ("Adjust" DIP Switch at "NORM" Setting)</b>																					
"COOL" Speed	Low	6	18	29	40	50	60	71	92	92	20	33	45	59	73	89	103	116	128	140	152
	Med Low	13	25	38	51	66	78	89	101	112	37	53	70	88	102	118	137	155	172	190	208
	Med High	19	34	49	64	78	93	110	124	135	58	80	103	125	144	164	184	204	223	243	262
	High	37	55	73	88	106	122	140	158	177	116	145	173	201	225	251	277	304	333	362	390
<b>"—" (Minus) SETTING ("Adjust" DIP Switch at "—" Setting)</b>																					
"COOL" Speed	Low	4	15	26	37	46	57	67	87	87	15	27	39	53	67	80	93	104	116	128	139
	Med Low	10	22	34	48	59	70	82	93	103	28	43	58	73	87	103	122	137	153	168	184
	Med High	15	29	43	55	70	85	98	109	122	45	65	84	103	120	140	158	176	195	213	231
	High	27	44	60	75	91	108	124	141	158	81	108	135	159	181	204	225	248	273	299	324

## BLOWER DATA

### ML180UH070V36B BLOWER PERFORMANCE (less filter)

#### SINGLE SIDE RETURN AIR

0 through 0.8 in. w.g. (Heating) and 0 through 1.0 in. w.g. (Cooling) External Static Pressure Range

"ADJUST" Switch Positions	Speed Switch Positions							
	"HEAT" Speed - cfm				Second Stage "COOL" Speed - cfm			
	Low	<sup>1</sup> Med-Low	Med-Hi	High	Low	Med-Low	Med-Hi	<sup>1</sup> High
+	850	950	1055	1190	625	805	995	1275
<sup>1</sup> NORM	775	875	960	1080	570	730	910	1150
—	710	795	865	980	525	660	825	1025
"ADJUST" Switch Positions	First Stage "COOL" Speed - cfm							
	Low	Med-Low	Med-Hi	<sup>1</sup> High				
	+	435	560	665	825			
<sup>1</sup> NORM	400	515	605	745				
—	365	470	555	680				

<sup>1</sup> Factory default DIP switch setting.

NOTES - The effect of static pressure is included in air volumes shown.

First stage COOL (two-stage air conditioning units only) is approximately 70% of the same second stage COOL speed position.

Continuous Fan Only speed is approximately 38% of the same second stage COOL speed position - minimum 350 cfm.

Lennox Harmony III™ Zoning System Applications - Minimum blower speed is 350 cfm.

### ML180UH070V36B BLOWER MOTOR WATTS (COOLING)

DIP Switch Speed Positions	Motor Watts @ Various External Static Pressures - in. wg.																				
	First Stage										Second Stage										
	0	0.1	0.2	0.3	0.4	0.5	0.6	0.7	0.8	0	0.1	0.2	0.3	0.4	0.5	0.6	0.7	0.8	0.9	1.0	
<b>"+" (Plus) SETTING ("Adjust" DIP Switch at "+" Setting)</b>																					
"COOL" Speed	Low	7	18	30	42	54	64	75	86	97	21	35	49	63	76	92	108	122	137	152	167
	Med Low	15	28	40	54	67	81	95	107	120	42	59	76	95	112	129	146	165	184	202	220
	Med High	25	40	55	69	84	99	115	130	146	71	96	122	146	168	187	206	232	249	267	284
	High	44	62	80	98	116	134	153	171	188	145	179	212	243	273	303	337	361	393	426	459
<b>"NORM" (Normal) SETTING ("Adjust" DIP Switch at "NORM" Setting)</b>																					
"COOL" Speed	Low	5	16	28	38	50	60	71	82	92	18	30	42	57	69	85	98	112	125	138	151
	Med Low	12	24	37	48	63	75	87	100	111	31	48	65	81	97	114	129	147	165	183	201
	Med High	19	33	46	61	74	89	103	118	132	59	78	98	120	141	159	178	197	215	233	251
	High	33	51	69	86	101	117	133	150	169	110	138	166	192	220	246	273	293	318	343	367
<b>"—" (Minus) SETTING ("Adjust" DIP Switch at "—" Setting)</b>																					
"COOL" Speed	Low	3	15	26	36	46	57	68	87	87	13	25	38	50	64	76	89	102	114	126	138
	Med Low	8	21	33	44	57	69	80	92	103	24	40	55	70	84	100	116	132	147	161	175
	Med High	15	28	40	54	67	81	94	108	120	42	61	81	99	117	133	152	170	186	203	219
	High	26	42	58	73	88	102	119	136	151	82	105	128	152	178	200	218	246	267	289	311

## BLOWER DATA

### ML180UH070V48B BLOWER PERFORMANCE (less filter)

#### BOTTOM RETURN AIR

0 through 0.8 in. w.g. (Heating) and 0 through 1.0 in. w.g. (Cooling) External Static Pressure Range

"ADJUST" Switch Positions	Speed Switch Positions							
	"HEAT" Speed - cfm				Second Stage "COOL" Speed - cfm			
	Low	<sup>1</sup> Med-Low	Med-Hi	High	Low	Med-Low	Med-Hi	<sup>1</sup> High
+	1410	1550	1750	1930	1045	1375	1640	1850
<sup>1</sup> NORM	1285	1410	1615	1770	940	1250	1500	1700
—	1155	1270	1445	1620	850	1115	1365	1540
"ADJUST" Switch Positions	First Stage "COOL" Speed - cfm							
	Low	Med-Low	Med-Hi	<sup>1</sup> High				
	+	615	870	1065	1240			
<sup>1</sup> NORM	525	780	960	1130				
—	430	685	870	990				

<sup>1</sup> Factory default DIP switch setting.

NOTES - The effect of static pressure is included in air volumes shown.

First stage COOL (two-stage air conditioning units only) is approximately 70% of the same second stage COOL speed position.

Continuous Fan Only speed is approximately 38% of the same second stage COOL speed position - minimum 400 cfm.

Lennox Harmony III™ Zoning System Applications - Minimum blower speed is 400 cfm.

### ML180UH070V48B BLOWER MOTOR WATTS (COOLING)

DIP Switch Speed Positions	Motor Watts @ Various External Static Pressures - in. wg.																				
	First Stage										Second Stage										
	0	0.1	0.2	0.3	0.4	0.5	0.6	0.7	0.8	0	0.1	0.2	0.3	0.4	0.5	0.6	0.7	0.8	0.9	1.0	
<b>"+" (Plus) SETTING ("Adjust" DIP Switch at "+" Setting)</b>																					
"COOL" Speed	Low	24	38	51	66	82	101	130	148	165	79	99	119	148	171	196	220	243	265	287	309
	Med Low	31	58	85	103	131	151	176	196	220	148	186	224	250	285	315	343	370	393	415	438
	Med High	75	101	127	157	180	204	227	254	276	268	308	348	388	426	462	497	533	556	579	601
	High	115	145	174	204	237	261	286	310	335	377	426	476	528	571	614	657	695	730	764	799
<b>"NORM" (Normal) SETTING ("Adjust" DIP Switch at "NORM" Setting)</b>																					
"COOL" Speed	Low	18	29	41	54	77	89	108	128	144	55	75	95	125	144	167	187	215	237	260	282
	Med Low	33	51	69	90	113	133	157	178	201	102	140	177	209	236	263	293	312	337	361	385
	Med High	48	76	105	128	152	179	195	220	244	192	236	280	313	350	380	414	443	470	443	470
	High	82	112	142	171	194	218	244	269	292	291	334	378	419	461	502	539	573	606	640	673
<b>"—" (Minus) SETTING ("Adjust" DIP Switch at "—" Setting)</b>																					
"COOL" Speed	Low	8	21	34	48	63	81	96	111	125	33	56	78	102	124	142	168	188	212	235	258
	Med Low	30	45	60	75	93	110	142	164	186	84	112	140	166	194	219	244	267	288	309	330
	Med High	38	60	82	107	125	149	170	194	218	133	175	217	245	278	311	334	365	390	415	440
	High	57	84	111	139	160	180	201	230	251	224	257	291	329	367	402	433	467	491	515	539



## BLOWER DATA

### ML180UH070V48B BLOWER PERFORMANCE (less filter)

#### SINGLE SIDE RETURN AIR

0 through 0.8 in. w.g. (Heating) and 0 through 1.0 in. w.g. (Cooling) External Static Pressure Range

"ADJUST" Switch Positions	Speed Switch Positions							
	"HEAT" Speed - cfm				Second Stage "COOL" Speed - cfm			
	Low	<sup>1</sup> Med-Low	Med-Hi	High	Low	Med-Low	Med-Hi	<sup>1</sup> High
+	1335	1475	1650	1840	980	1290	1550	1760
<sup>1</sup> NORM	1225	1355	1520	1690	900	1175	1415	1610
—	1090	1215	1375	1500	810	1060	1280	1450
"ADJUST" Switch Positions	First Stage "COOL" Speed - cfm							
	Low	Med-Low	Med-Hi	<sup>1</sup> High				
	+	605	820	1000	1155			
<sup>1</sup> NORM	520	780	920	1060				
—	420	670	810	935				

<sup>1</sup> Factory default DIP switch setting.

NOTES - The effect of static pressure is included in air volumes shown.

First stage COOL (two-stage air conditioning units only) is approximately 70% of the same second stage COOL speed position.

Continuous Fan Only speed is approximately 38% of the same second stage COOL speed position - minimum 400 cfm.

Lennox Harmony III™ Zoning System Applications - Minimum blower speed is 400 cfm.

### ML180UH070V48B BLOWER MOTOR WATTS (COOLING)

DIP Switch Speed Positions	Motor Watts @ Various External Static Pressures - in. wg.																				
	First Stage										Second Stage										
	0	0.1	0.2	0.3	0.4	0.5	0.6	0.7	0.8	0	0.1	0.2	0.3	0.4	0.5	0.6	0.7	0.8	0.9	1.0	
<b>"+" (Plus) SETTING ("Adjust" DIP Switch at "+" Setting)</b>																					
"COOL" Speed	Low	19	34	49	71	87	105	121	141	160	57	83	109	134	161	189	217	243	275	307	339
	Med Low	28	51	75	101	129	155	180	214	235	123	162	201	233	263	296	324	351	382	413	444
	Med High	62	89	116	144	166	195	221	248	273	246	282	318	364	398	429	464	496	531	566	601
	High	99	130	161	189	218	242	269	297	330	377	407	436	472	536	567	612	639	677	715	753
<b>"NORM" (Normal) SETTING ("Adjust" DIP Switch at "NORM" Setting)</b>																					
"COOL" Speed	Low	10	27	43	57	72	89	104	122	138	43	65	87	113	138	166	189	222	254	285	317
	Med Low	31	46	61	89	110	141	166	192	216	100	130	161	190	216	245	274	304	335	366	397
	Med High	40	67	93	119	144	171	195	227	260	181	217	252	287	324	355	387	415	450	443	470
	High	75	101	128	157	186	211	236	265	290	254	308	361	395	429	470	504	544	567	590	613
<b>"—" (Minus) SETTING ("Adjust" DIP Switch at "—" Setting)</b>																					
"COOL" Speed	Low	8	21	35	47	59	72	92	106	123	28	49	70	92	119	151	179	203	226	250	274
	Med Low	24	41	57	78	99	116	137	158	178	67	97	127	153	179	207	232	264	291	319	347
	Med High	28	51	74	96	123	152	183	209	237	136	166	196	226	256	288	319	346	373	399	426
	High	46	72	97	124	148	177	204	231	263	202	233	265	307	338	376	409	439	473	507	541

## BLOWER DATA

### ML180UH090V48B BLOWER PERFORMANCE (less filter)

#### BOTTOM RETURN AIR

0 through 0.8 in. w.g. (Heating) and 0 through 1.0 in. w.g. (Cooling) External Static Pressure Range

"ADJUST" Switch Positions	Speed Switch Positions							
	"HEAT" Speed - cfm				Second Stage "COOL" Speed - cfm			
	Low	<sup>1</sup> Med-Low	Med-Hi	High	Low	Med-Low	Med-Hi	<sup>1</sup> High
+	1315	1445	1575	1775	1070	1300	1550	1740
<sup>1</sup> NORM	1195	1315	1430	1615	1000	1210	1410	1600
—	1075	1180	1285	1450	880	1115	1295	1465
"ADJUST" Switch Positions	First Stage "COOL" Speed - cfm							
	Low	Med-Low	Med-Hi	<sup>1</sup> High				
	+	750	910	1050	1180			
<sup>1</sup> NORM	730	875	990	1120				
—	650	800	940	1010				

<sup>1</sup> Factory default DIP switch setting.

NOTES - The effect of static pressure is included in air volumes shown.

First stage COOL (two-stage air conditioning units only) is approximately 70% of the same second stage COOL speed position.

Continuous Fan Only speed is approximately 38% of the same second stage COOL speed position - minimum 400 cfm.

Lennox Harmony III™ Zoning System Applications - Minimum blower speed is 400 cfm.

### ML180UH090V48B BLOWER MOTOR WATTS (COOLING)

DIP Switch Speed Positions	Motor Watts @ Various External Static Pressures - in. wg.																				
	First Stage										Second Stage										
	0	0.1	0.2	0.3	0.4	0.5	0.6	0.7	0.8	0	0.1	0.2	0.3	0.4	0.5	0.6	0.7	0.8	0.9	1.0	
<b>"+" (Plus) SETTING ("Adjust" DIP Switch at "+" Setting)</b>																					
"COOL" Speed	Low	37	56	75	86	105	128	141	157	173	64	97	130	155	194	220	245	278	307	335	364
	Med Low	67	86	105	122	146	169	187	207	227	123	156	189	222	263	294	324	367	402	437	472
	Med High	97	119	141	163	189	213	237	261	286	242	272	303	337	378	417	455	495	539	583	627
	High	124	156	188	219	248	281	308	338	366	353	384	416	451	508	548	587	637	687	737	787
<b>"NORM" (Normal) SETTING ("Adjust" DIP Switch at "NORM" Setting)</b>																					
"COOL" Speed	Low	38	51	64	79	92	107	122	138	159	47	77	108	140	165	199	223	254	281	309	336
	Med Low	45	65	85	114	130	148	173	179	200	92	126	161	191	229	261	286	322	362	401	440
	Med High	79	98	117	136	159	177	187	207	244	179	211	242	276	313	359	393	432	467	503	538
	High	95	122	149	180	194	230	252	278	300	267	300	333	368	412	457	499	538	572	607	641
<b>"—" (Minus) SETTING ("Adjust" DIP Switch at "—" Setting)</b>																					
"COOL" Speed	Low	31	44	57	71	82	95	107	121	132	38	68	97	118	153	181	204	231	261	290	319
	Med Low	44	60	76	91	109	127	143	159	176	99	118	137	176	206	236	269	295	328	361	394
	Med High	46	70	94	116	132	157	171	190	206	122	158	194	225	265	294	340	369	405	441	477
	High	77	100	123	147	166	187	210	231	253	201	227	254	296	337	379	417	455	489	523	558

## BLOWER DATA

### ML180UH090V48B BLOWER PERFORMANCE (less filter)

#### SINGLE SIDE RETURN AIR

0 through 0.8 in. w.g. (Heating) and 0 through 1.0 in. w.g. (Cooling) External Static Pressure Range

"ADJUST" Switch Positions	Speed Switch Positions							
	"HEAT" Speed - cfm				Second Stage "COOL" Speed - cfm			
	Low	<sup>1</sup> Med-Low	Med-Hi	High	Low	Med-Low	Med-Hi	<sup>1</sup> High
+	1315	1445	1575	1775	1035	1285	1500	1690
<sup>1</sup> NORM	1195	1315	1430	1615	975	1175	1385	1560
—	1075	1180	1285	1450	895	1080	1255	1410
"ADJUST" Switch Positions	First Stage "COOL" Speed - cfm							
	Low	Med-Low	Med-Hi	<sup>1</sup> High				
	+	765	900	1025	1145			
<sup>1</sup> NORM	725	845	970	1045				
—	650	760	870	945				

<sup>1</sup> Factory default DIP switch setting.

NOTES - The effect of static pressure is included in air volumes shown.

First stage COOL (two-stage air conditioning units only) is approximately 70% of the same second stage COOL speed position.

Continuous Fan Only speed is approximately 38% of the same second stage COOL speed position - minimum 400 cfm.

Lennox Harmony III™ Zoning System Applications - Minimum blower speed is 400 cfm.

### ML180UH090V48B BLOWER MOTOR WATTS (COOLING)

DIP Switch Speed Positions	Motor Watts @ Various External Static Pressures - in. wg.																				
	First Stage										Second Stage										
	0	0.1	0.2	0.3	0.4	0.5	0.6	0.7	0.8	0	0.1	0.2	0.3	0.4	0.5	0.6	0.7	0.8	0.9	1.0	
<b>"+" (Plus) SETTING ("Adjust" DIP Switch at "+" Setting)</b>																					
"COOL" Speed	Low	39	54	70	93	122	146	167	191	222	56	83	109	144	181	203	238	260	297	335	372
	Med Low	38	64	91	119	147	176	208	232	264	104	142	179	220	258	301	327	370	403	437	470
	Med High	55	86	116	156	185	205	241	275	302	165	208	251	304	339	389	439	479	528	577	626
	High	59	102	146	179	215	243	278	310	342	232	296	361	416	458	510	556	613	651	689	728
<b>"NORM" (Normal) SETTING ("Adjust" DIP Switch at "NORM" Setting)</b>																					
"COOL" Speed	Low	31	47	62	85	115	130	180	187	208	27	64	101	131	160	191	224	248	283	317	351
	Med Low	25	50	76	113	137	162	190	224	242	72	109	147	184	218	257	291	328	362	396	431
	Med High	36	71	106	130	161	192	225	249	283	120	166	212	245	293	337	372	403	449	495	541
	High	45	84	123	149	183	208	243	269	308	183	230	277	327	373	414	468	501	552	603	654
<b>"—" (Minus) SETTING ("Adjust" DIP Switch at "—" Setting)</b>																					
"COOL" Speed	Low	15	42	68	86	108	129	159	176	203	27	54	82	113	148	163	197	228	258	289	319
	Med Low	31	51	72	103	123	154	172	209	232	72	99	127	154	193	231	259	287	325	363	401
	Med High	36	61	87	123	137	176	201	230	259	98	136	173	207	247	287	309	360	383	405	428
	High	31	66	101	127	165	194	213	253	284	147	187	226	262	303	351	391	438	473	508	543

## BLOWER DATA

### ML180UH090V48B BLOWER PERFORMANCE (less filter)

#### SINGLE SIDE RETURN AIR WITH OPTIONAL RETURN AIR BASE

0 through 0.8 in. w.g. (Heating) and 0 through 1.0 in. w.g. (Cooling) External Static Pressure Range

"ADJUST" Switch Positions	Speed Switch Positions							
	"HEAT" Speed - cfm				Second Stage "COOL" Speed - cfm			
	Low	<sup>1</sup> Med-Low	Med-Hi	High	Low	Med-Low	Med-Hi	<sup>1</sup> High
+	1315	1445	1575	1775	985	1250	1480	1670
<sup>1</sup> NORM	1195	1315	1430	1615	925	1150	1350	1525
—	1075	1180	1285	1450	840	1060	1235	1380
"ADJUST" Switch Positions	First Stage "COOL" Speed - cfm							
	Low	Med-Low	Med-Hi	<sup>1</sup> High				
+					740	900	1030	1150
<sup>1</sup> NORM					680	850	950	1060
—					650	750	870	980

<sup>1</sup> Factory default DIP switch setting.

NOTES - The effect of static pressure is included in air volumes shown.

First stage COOL (two-stage air conditioning units only) is approximately 70% of the same second stage COOL speed position.

Continuous Fan Only speed is approximately 38% of the same second stage COOL speed position - minimum 400 cfm.

Lennox Harmony III™ Zoning System Applications - Minimum blower speed is 400 cfm.

### ML180UH090V48B BLOWER MOTOR WATTS (COOLING)

DIP Switch Speed Positions	Motor Watts @ Various External Static Pressures - in. wg.																				
	First Stage										Second Stage										
	0	0.1	0.2	0.3	0.4	0.5	0.6	0.7	0.8	0	0.1	0.2	0.3	0.4	0.5	0.6	0.7	0.8	0.9	1.0	
<b>"+" (Plus) SETTING ("Adjust" DIP Switch at "+" Setting)</b>																					
"COOL" Speed	Low	26	49	71	97	117	137	167	191	215	36	71	106	132	164	197	221	251	289	326	363
	Med Low	32	64	97	119	151	177	207	232	264	90	129	168	206	230	279	314	350	389	427	465
	Med High	41	80	119	144	183	205	243	271	298	178	207	237	277	311	358	403	443	487	530	573
	High	69	98	126	163	199	232	271	303	338	282	315	348	392	427	461	522	571	605	639	674
<b>"NORM" (Normal) SETTING ("Adjust" DIP Switch at "NORM" Setting)</b>																					
"COOL" Speed	Low	30	47	63	87	104	130	149	176	197	46	63	81	128	146	171	211	235	259	284	308
	Med Low	39	57	76	112	140	160	193	212	241	65	100	136	169	208	238	276	307	337	366	395
	Med High	34	66	98	128	155	186	216	244	271	126	156	187	237	267	305	347	394	431	467	503
	High	49	86	122	152	192	227	253	287	317	217	239	260	298	340	385	435	479	509	539	570
<b>"—" (Minus) SETTING ("Adjust" DIP Switch at "—" Setting)</b>																					
"COOL" Speed	Low	29	47	64	92	117	141	163	190	207	6	48	89	105	128	158	182	209	243	276	309
	Med Low	37	54	72	95	120	142	162	191	221	55	87	118	147	184	212	245	265	311	357	403
	Med High	18	51	85	114	144	172	193	219	248	93	133	173	201	236	280	309	343	376	409	442
	High	43	73	103	136	164	201	220	250	281	141	176	211	237	279	332	363	408	440	471	502

## BLOWER DATA

### ML180UH110V60C BLOWER PERFORMANCE (less filter)

#### BOTTOM RETURN AIR, RETURN AIR FROM BOTH SIDES OR RETURN AIR FROM BOTTOM AND ONE SIDE

0 through 0.8 in. w.g. (Heating) and 0 through 1.0 in. w.g. (Cooling) External Static Pressure Range

"ADJUST" Switch Positions	Speed Switch Positions							
	"HEAT" Speed - cfm				Second Stage "COOL" Speed - cfm			
	Low	<sup>1</sup> Med-Low	Med-Hi	High	Low	Med-Low	Med-Hi	<sup>1</sup> High
+	1530	1700	1850	2150	1560	1765	1980	2180
<sup>1</sup> NORM	1400	1560	1730	1960	1425	1620	1800	2000
—	1260	1400	1560	1764	1280	1460	1620	1800
"ADJUST" Switch Positions	First Stage "COOL" Speed - cfm							
	Low	Med-Low	Med-Hi	<sup>1</sup> High				
	+	1125	1275	1420	1585			
<sup>1</sup> NORM	1030	1165	1290	1450				
—	930	1050	1160	1305				

<sup>1</sup> Factory default DIP switch setting.

NOTES - The effect of static pressure is included in air volumes shown.

First stage COOL (two-stage air conditioning units only) is approximately 70% of the same second stage COOL speed position.

Continuous Fan Only speed is approximately 38% of the same second stage COOL speed position - minimum 550 cfm.

Lennox Harmony III™ Zoning System Applications - Minimum blower speed is 550 cfm.

### ML180UH110V60C BLOWER MOTOR WATTS (COOLING)

DIP Switch Speed Positions	Motor Watts @ Various External Static Pressures - in. wg.																				
	First Stage										Second Stage										
	0	0.1	0.2	0.3	0.4	0.5	0.6	0.7	0.8	0	0.1	0.2	0.3	0.4	0.5	0.6	0.7	0.8	0.9	1.0	
<b>"+" (Plus) SETTING ("Adjust" DIP Switch at "+" Setting)</b>																					
"COOL" Speed	Low	75	99	123	148	172	197	221	247	271	157	194	231	264	297	332	367	399	433	467	502
	Med Low	94	122	151	179	205	232	259	288	314	228	267	306	342	384	423	463	500	539	578	617
	Med High	125	156	186	216	247	278	308	336	363	307	354	402	444	491	541	583	623	672	721	771
	High	164	200	236	269	303	336	372	405	438	415	468	521	575	717	684	736	786	847	908	969
<b>"NORM" (Normal) SETTING ("Adjust" DIP Switch at "NORM" Setting)</b>																					
"COOL" Speed	Low	61	83	105	128	151	174	197	221	244	126	159	193	223	253	282	314	344	374	405	436
	Med Low	82	107	132	157	181	207	233	260	286	182	217	252	288	321	358	392	429	462	496	529
	Med High	99	128	156	183	209	230	266	292	323	245	284	322	366	405	447	485	525	566	606	647
	High	128	162	192	225	254	287	318	348	375	311	361	411	456	506	550	597	649	692	736	780
<b>"—" (Minus) SETTING ("Adjust" DIP Switch at "—" Setting)</b>																					
"COOL" Speed	Low	50	70	90	111	133	155	175	198	220	101	131	161	188	216	239	269	296	323	351	378
	Med Low	71	93	116	138	160	185	210	234	261	145	176	207	243	269	302	332	368	396	425	454
	Med High	78	105	131	154	177	204	230	253	287	196	227	258	301	334	370	403	442	476	509	542
	High	100	132	156	188	212	245	271	299	321	234	278	323	362	415	443	485	536	566	597	628

## BLOWER DATA

### ML180UH110V60C BLOWER PERFORMANCE (less filter)

**SINGLE SIDE RETURN AIR** – Air volumes in bold (over 1800 cfm) require Optional Return Air Base and field fabricated transition to accommodate 20 x 25 x 1 in. air filter in order to maintain proper air velocity.

**0 through 0.8 in. w.g. (Heating) and 0 through 1.0 in. w.g. (Cooling) External Static Pressure Range**

“ADJUST” Switch Positions	Speed Switch Positions							
	“HEAT” Speed - cfm				Second Stage “COOL” Speed - cfm			
	Low	<sup>1</sup> Med-Low	Med-Hi	High	Low	Med-Low	Med-Hi	<sup>1</sup> High
+	1500	1635	1820	2085	1650	<b>1860</b>	<b>2080</b>	<b>2330</b>
<sup>1</sup> NORM	1370	1500	1665	1905	1500	1700	<b>1895</b>	<b>2080</b>
—	1235	1350	1500	1715	1350	1530	1705	1870
“ADJUST” Switch Positions	First Stage “COOL” Speed - cfm							
	Low	Med-Low	Med-Hi	<sup>1</sup> High				
	+	1200	1350	1500	1665			
<sup>1</sup> NORM	1090	1235	1375	1525				
—	980	1110	1235	1370				

<sup>1</sup> Factory default DIP switch setting.

NOTES - The effect of static pressure is included in air volumes shown.

First stage COOL (two-stage air conditioning units only) is approximately **70%** of the same second stage COOL speed position.

Continuous Fan Only speed is approximately **38%** of the same second stage COOL speed position - minimum 550 cfm.

Lennox Harmony III™ Zoning System Applications - Minimum blower speed is 550 cfm.

### ML180UH110V60C BLOWER MOTOR WATTS (COOLING)

DIP Switch Speed Positions	Motor Watts @ Various External Static Pressures - in. wg.																				
	First Stage										Second Stage										
	0	0.1	0.2	0.3	0.4	0.5	0.6	0.7	0.8	0	0.1	0.2	0.3	0.4	0.5	0.6	0.7	0.8	0.9	1.0	
<b>“+” (Plus) SETTING (“Adjust” DIP Switch at “+” Setting)</b>																					
“COOL” Speed	Low	87	109	132	160	191	214	249	271	298	187	227	267	303	336	370	413	448	489	529	569
	Med Low	121	147	174	205	235	269	295	325	362	283	324	365	405	449	489	536	582	621	660	699
	Med High	152	189	225	256	286	315	348	385	423	387	441	496	541	585	647	683	741	788	835	882
	High	212	249	287	325	363	396	441	468	502	561	621	681	735	789	843	917	966	1019	1072	1125
<b>“NORM” (Normal) SETTING (“Adjust” DIP Switch at “NORM” Setting)</b>																					
“COOL” Speed	Low	54	87	119	142	164	191	215	242	262	145	178	211	245	276	309	343	378	409	441	472
	Med Low	91	117	144	171	197	225	268	285	308	200	244	287	316	358	393	432	471	512	553	594
	Med High	116	148	181	204	242	267	297	326	363	293	336	379	419	467	500	542	577	636	696	756
	High	155	192	228	256	295	332	357	395	433	386	441	497	538	587	644	691	723	794	866	937
<b>“—” (Minus) SETTING (“Adjust” DIP Switch at “—” Setting)</b>																					
“COOL” Speed	Low	34	69	108	125	141	170	186	215	230	112	139	167	197	227	258	286	318	343	367	391
	Med Low	68	93	118	142	166	188	243	249	262	142	183	225	246	286	316	348	381	422	464	505
	Med High	88	117	145	163	204	226	254	276	312	221	255	289	324	373	387	431	449	514	580	648
	High	114	147	181	202	240	278	290	334	373	265	314	363	393	436	492	521	541	619	700	781





Visit us at [www.lennox.com](http://www.lennox.com)

For the latest technical information, [www.LennoxPros.com](http://www.LennoxPros.com)

Contact us at 1-800-4-LENNOX

NOTE - Due to Lennox' ongoing commitment to quality, Specifications, Ratings and Dimensions subject to change without notice and without incurring liability.  
Improper installation, adjustment, alteration, service or maintenance can cause property damage or personal injury.  
Installation and service must be performed by a qualified installer and servicing agency.

©2019 Lennox Industries, Inc.