



**ML193DFE**

**MERIT® SERIES**

**Downflow - High Efficiency Blower**

**RESIDENTIAL  
PRODUCT SPECIFICATIONS**

Bulletin No. 210868  
April 2021  
Supersedes July 2020



**MERIT®  
SERIES**



**QUALIFIED ONLY IN**  
**U.S. SOUTH:** AL, AZ, AR, CA, DC, DE, FL, GA, HI, KY, LA, MD, MS, NV, NM, NC, OK, SC, TN, TX, VA



QUALIFIED

**AFUE - 93%**  
**Input - 44,000 to 88,000 Btuh**  
**Nominal Add-on Cooling - 1.5 to 4 Tons**

**MODEL NUMBER IDENTIFICATION**

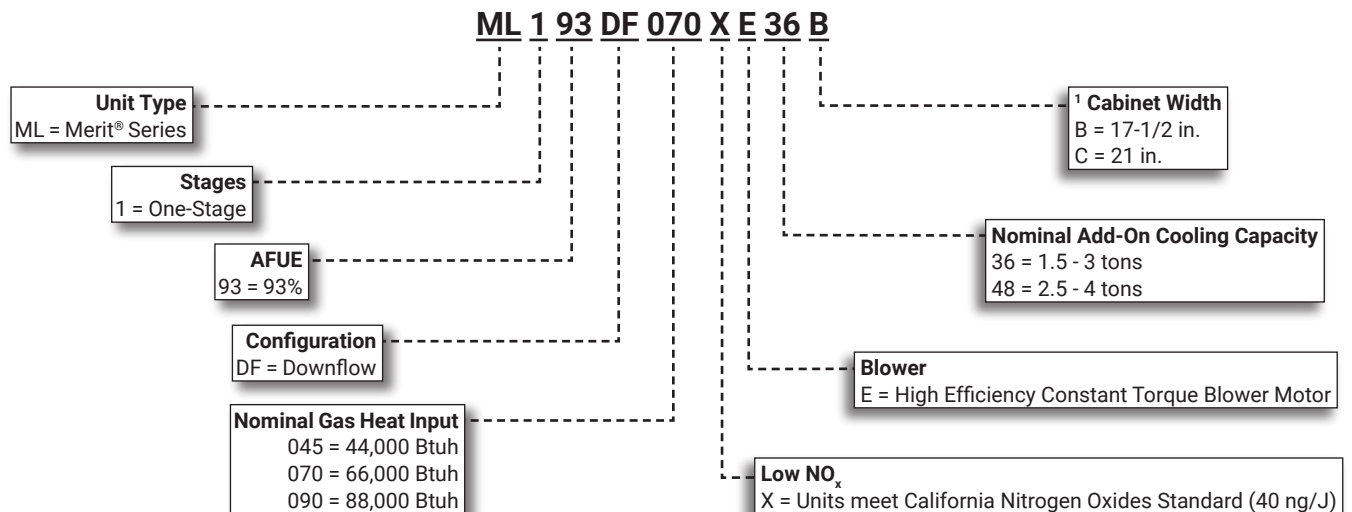

<sup>1</sup> Downflow indoor coils with the same letter designation will physically match the furnace supply air opening.

## FEATURE HIGHLIGHTS

1. Lennox Duralok Plus™ Heat Exchanger
2. Secondary Heat Exchanger
3. Inshot Burners
4. Gas Control Valve
5. Combustion Air Inducer
6. SureLight® Integrated Furnace Control
7. Power Saver™ Constant Torque Blower
8. Insulated Cabinet
9. Safety Interlock Switch
10. Gas Piping And Electrical Inlets



## CONTENTS

Approvals and Warranty . . . . .	3
Blower Data . . . . .	19
Dimensions - Furnace/Coil Combined Dimensions . . . . .	15
Dimensions - Optional Accessories . . . . .	14
Dimensions - Optional Accessories - Venting . . . . .	16
Dimensions - Unit . . . . .	13
Features . . . . .	3
Gas Heat Accessories . . . . .	10
High Altitude Derate . . . . .	10
Installation Clearances . . . . .	8
Optional Accessories . . . . .	9
Specifications . . . . .	8
Vent Lengths . . . . .	11
Vent Lengths - Uninsulated Exhaust Pipe In Unconditioned Space . . . . .	10

## APPROVALS AND WARRANTY

### APPROVALS

- AHRI Certified
- Tested and rated according to US DOE test procedures and FTC labeling regulations
- Approved by the California Energy Commission and meets California Nitrogen Oxides Standard (NOx) limits of 40 ng/J
- ENERGY STAR® units are certified only in the U.S. South in certain states and are designed to use less energy, help save money on utility bills, and help protect the environment
- ISO 9001 Registered Manufacturing Quality System
- Blower data from unit tests conducted in Lennox Laboratory air test chamber

### California Only

- These furnaces **do not meet** the South Coast Air Quality Management District (SCAQMD) Rule 1111 and San Joaquin Valley Air Pollution Control District (SJVAPCD) Rule 4905 NOx emission limit (14 ng/J) and cannot be installed within the SCAQMD and SJVAPCD areas
- These furnaces are approved by the California Energy Commission and meets California Nitrogen Oxides Standard (NOx) limits of 40 ng/J

### WARRANTY

- Duralok Plus™ Aluminized Steel Heat Exchanger:
  - Limited twenty year in residential applications
  - Limited ten years in non-residential applications
- All other covered components:
  - Limited five years in residential installations
  - Limited one year in non-residential installations

**NOTE** - Refer to Lennox Equipment Limited Warranty certificate included with unit for specific details.

## FEATURES

### APPLICATIONS

- Input capacities of 44,000, 66,000 and 88,000 Btuh.
- Energy efficiency (AFUE) 93%.
- Lennox add-on indoor coils, high-efficiency air cleaners and humidifiers can easily be added to furnace.
- Shipped factory assembled with controls installed and wired.
- Each unit factory test operated to ensure proper operation.

### HEATING SYSTEM

- 1 **Lennox Duralok Plus™ Heat Exchanger Assembly**
  - Lennox developed heat exchanger assembly consists of primary heat exchanger and secondary condenser coil assembly.
  - Main multi-pass crimped seam design clamshell type heat exchanger.
  - Constructed of heavy-gauge, aluminized steel.
  - Designed for normal expansion and contraction with maximum efficiency and minimum resistance to air flow.
- 2
  - Secondary heat exchanger condenser coil constructed of aluminum fins fitted to stainless steel tubes.
  - Coil is factory tested for leaks.

- Condensate drain header box assembly located on front of coil.
- Compact size of complete heat exchanger assembly permits low overall design of furnace cabinet.
- Heat exchanger assembly has been laboratory life cycle tested in excess of industry standards.

### Lennox Designed Header Box

- Header box on end of condenser coil collects flue condensate for disposal through condensate drains.
- The drains are located on each side of the cabinet for easy field installation of condensate drain trap.
- Only one drain is used, the other drain is sealed.
- Condensate drain trap is included with unit for field installation.

## FEATURES

### **HEATING SYSTEM (continued)**

#### **Lennox Designed Flue Condensate Trap Assembly**

- Field installed outside the conditioned air stream
- Assembly can be mounted on either side of cabinet in upflow applications
- Assembly is mounted below the cabinet in horizontal applications
- Can also be mounted remotely (up to 5 ft. away) from unit
- See Dimension Drawing and Installation Instructions
- 90° street elbow furnished for ease of drain trap installation
- Drain connection can be made with field provided PVC pipe or PVC coupling
- Drain cap on trap allows easy cleaning and winterizing

#### **3 Inshot Burners**

- Aluminized steel inshot burners provide efficient, trouble-free operation
- Burner venturi mixes air and gas in correct proportion for proper combustion
- Burner assembly can be removed from the unit as a single component for ease of service

#### **SureLight® Hot Surface Ignitor**

- Tough, reliable, long-life, trouble-free performance
- Silicon nitride ignitor
- Cemented to steatite block for protection against current leakage
- Ignition leads are constructed of nickel plated copper and are enclosed in high temperature Teflon® insulation for dependable operation

#### **4 Gas Control Valve**

- 24 volt redundant combination gas control valve combines manual shut off switch (On-Off), automatic electric valve (dual) and gas pressure regulation into a compact combination control

#### **Flame Rollout Switches (2)**

- Factory installed on the front of the burner box
- Switch provides protection from abnormal operating conditions
- Manual reset

#### **Limit Control**

- Automatic reset, primary limit is accurately located on header box on all units

#### **5 Combustion Air Inducer**

- Shaded pole heavy duty blower prepurges heat exchanger and safely vents flue products
- Operates only during heating cycle

#### **Pressure Switch**

- Proves Combustion Air Inducer operation before allowing gas valve to open

### **Optional Accessories**

#### **High Altitude Orifice Kits**

- Required on all units for proper operation at altitudes from 7501 to 10,000 ft.
- Kits are available for natural gas and LPG/propane

#### **High Altitude Pressure Switch Kit**

- Required for proper unit operation on installations above 4500 ft.

#### **Natural Gas to LPG/Propane Conversion Kit**

- Required for field changeover from natural gas to LPG/Propane

#### **LPG/Propane to Natural Gas Conversion Kit**

- Required for field changeover from LPG/Propane to natural gas

#### **Muffler (US Only)**

- Significantly reduces outdoor operating sound levels
- Two-inch diameter muffler is optional for all models
- Installed vertically in the exhaust piping
- See Optional Accessory Dimension Drawing

#### **DIRECT VENT / NON-DIRECT VENT SEALED COMBUSTION SYSTEM**

- Furnace features a "sealed combustion" system and can be installed in either Direct Vent or Non-Direct applications
- In Direct Vent applications, combustion air is supplied from outdoors and flue gases are discharged outdoors
- In Non-Direct Vent applications, combustion air is supplied from indoors and flue gases are discharged outdoors

**NOTE** - Lennox has approved the use of DuraVent® PolyPro® and Centrotherm InnoFlue® manufactured vent pipe and terminations as an alternative to PVC vent pipe. Must be ordered separately. Tested and listed to the ULC S636 standard in Canada.

- The polypropylene venting system must follow the uninsulated and unconditioned space vent lengths listed in the table on Page 10
- Refer to the Installation Instructions for additional details

## FEATURES

### **DIRECT VENT / NON-DIRECT VENT SEALED COMBUSTION SYSTEM (continued)**

#### **Flue Coupling**

- Assists with exhaust flue piping connection and servicing
- Includes flexible one 2-inch rubber coupling and two adjustable bands
- Approved for all Lennox 90% furnaces

#### **Vent Termination Kits**

- Facilitates installation of combustion air intake pipe and flue exhaust pipe
- Refer to venting table in this bulletin to determine pipe size needed and proper termination kit required
- See Optional Accessories table and dimension drawings

#### **Concentric Termination Kit - Direct Vent Applications**

- 2 or 3 inch kit contains concentric termination assembly, reducer bushing and 45° elbow
- 2 inch kit for -030-045-070 models contains an outdoor exhaust accelerator
- Kit requires single hole penetration of roof or wall for installation
- Roof Termination Flashing Kit is available for use with 2 inch Kits
- CSA certified

#### **Flush-Mount Termination Kit**

- Kit contains flush-mount termination, accelerator, mounting template and hardware
- Kit may be used with 2, 2-1/2 or 3 in. pipe

#### **Wall Assembly Termination Kits**

##### **Close Couple (US Only) - Direct Vent Applications**

- 2 or 3 inch kit consists of close-couple, side-by-side PVC piping with galvanized steel wall cover plate
- Seals and isolates intake and exhaust piping penetration of wall
- Piping spacing and length is sized for proper wall installations
- CSA certified

##### **Close Couple WTK (Canada Only) - Direct Vent Applications**

- 2 or 3 inch kit contains one insulated faceplate, one insulated exhaust pipe, elbow and fittings

**NOTE** - Maintain a maximum of 6 inches between the inlet and outlet openings in the installation of the pipes.

#### **Roof Termination Flashing Kit**

- For vertical venting through a roof
- 2 or 3 inch kit contains two neoprene rubber roof flashings
- Vent pipe and insulation not furnished
- Flashing Kit can also be used with Concentric Vent Termination Kits used in vertical venting rooftop applications

## **CONTROLS**

### **6 SureLight® Integrated Furnace Control**

- Contains all necessary controls and relays to operate furnace
- Combustion air inducer is operated by the integrated furnace control
- Prior to ignition, a pre-purge cycle for 15 seconds is initiated
- After the main burners are turned off, a post-purge cycle for 5 seconds is run
- Flame sensor assures safe and reliable operation
- Should loss of flame occur, the integrated furnace control will initiate 4 re-attempts at ignition before locking out unit operation for 60 minutes
- Watchguard type circuit automatically resets ignition controls after one hour of continuous thermostat demand after unit lockout, eliminating nuisance calls for service
- Fan control consists of adjustable blower timed-off delay (60, 90, 120, 180 seconds - factory setting 90 seconds) and fixed blower timed-on delay (30 seconds heating, 2 seconds cooling)
- For air-conditioning applications, blower is automatically energized on thermostat demand for cooling
- Two accessory terminals furnished for additional power supply requirements for 120 volt (less than 1 amp) power humidifiers and powered air cleaners
- One additional terminal is furnished for power supply requirements for 24V (less than 0.5 amp) low voltage accessories
- Ignition control has a single red LED to indicate status and as an aid in troubleshooting
- Last ten codes are stored in non-volatile memory (accessible by recall button on control) for servicing

### **24 Volt Transformer (40VA)**

- Fuse wired in series
- Furnished and factory installed in control box

### **Field Wiring Make-Up Box**

- Furnished for line voltage wiring
- Factory installed internally on left side of furnace
- Box may be installed internally or externally on either side of furnace

## FEATURES

### CONTROLS (continued)

#### Optional Accessories

##### iComfort® M30 Smart Wi-Fi Thermostat

- Wi-Fi-enabled, electronic 7-day, universal, multi-stage, programmable, touchscreen thermostat
- 4 Heat/2 Cool
- Auto-changeover
- Dual-fuel control with optional outdoor sensor
- Controls dehumidification during cooling mode and humidification during heating mode
- Offers enhanced capabilities including humidification / dehumidification / dewpoint measurement and control, Humiditol® control, and equipment maintenance reminders
- Easy to read 4.3 in. color touchscreen (measured diagonally)
- LCD display with backlight shows the current and set temperature, time, inside relative humidity, system status (operating mode and schedules) and outside temperature (optional outdoor sensor required)
- Smooth Setback Recovery starts system early to achieve setpoint at start of program period
- Compressor short-cycle protection (5 minutes)
- Up to four separate schedules are available plus Schedule IQ™
- One-Touch Away Mode - A quick and easy way to set the cooling and heating setpoints while away
- Smart Away™ - Uses geo-fencing technology to determine when the homeowner is within a predetermined distance from the home to operate the system when leaving, away and arriving
- Wi-Fi remote monitoring and adjustment through a home wireless network for desktop PCs, laptops and apps for smartphones or tablets
- Smart home automation compatible with Amazon Alexa®, Google Assistant and IFTTT
- Service Dashboard features online real-time monitoring of installed iComfort® thermostats

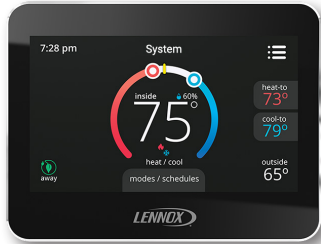

**NOTE** - See the iComfort® M30 Smart Wi-Fi Thermostat Product Specifications bulletin in the Controls section for more information.

##### Remote Outdoor Temperature Sensor

- Used with the iComfort® M30 Smart Thermostat
- Outdoor sensor allows thermostat to display outdoor temperature

**NOTE** - Sensor is required for the Enhanced Dehumidification Accessory (EDA).



##### Thermostat

- Thermostat is not furnished with unit
- See Lennox Price Book for selection

##### Blower Relay Kit (For Use With Two-Stage Outdoor Units)

- Allows furnace blower speed changes when matched with two-stage air conditioners or heat pumps

##### Furnace Twinning Kit

- Required to operate two furnaces simultaneously
- Kit consists of twinning relays, quick connect terminals and mounting hardware
- Used for single-stage heating/single-stage cooling with a single-stage thermostat

##### Night Service Kit

- Contains most commonly used service parts:
  - Furnace Control
  - Igniter
  - Flame Sensor
  - Gas Valve
  - Transformer
  - Service Manual

##### **BLOWER**

- Direct drive blower
- Statically and dynamically balanced
- Resiliently mounted
- Blower assembly easily removed for servicing
- 7 **Power Saver™ Constant Torque Blower Motor**
  - DC Brushless Motor
  - High Efficiency Constant Torque
  - ECM (Electronically Commutated Motor)
  - Motor is programmed to provide constant torque at each of the selectable speeds
  - Motor is controlled by the Integrated Furnace Control
  - Blower speeds are easily changed on the integrated furnace control
  - See Blower Data tables

## FEATURES

### **CABINET**

- Low-profile, narrow width allows easy installation
- Heavy-gauge, cold rolled steel construction
- Pre-painted cabinet finish
- Flanges provided on supply air opening for ease of plenum connection or alignment with indoor coil
- 8 • Insulated with foil faced insulation on sides and back of heating compartment
- Sealed blower compartment
- Complete service access
- 9 • Safety interlock switch automatically shuts off power to unit when blower compartment access door is remove
- 10 • Gas piping and electrical inlets are provided in both sides of cabinet

### **Coil Match-Up**

- All Lennox downflow indoor coils will physically match the furnace supply air opening with the same letter designation (A, B, C, D) as in the furnace model number

### **Low Leakage Cabinet**

- All models have less than 2% air leakage and meet ANSI/ASHRAE Standard 193-2010 "Method of Test for Determining the Air Tightness of HVAC Equipment"

### **Optional Accessories**

#### **Condensate Drain Heat Cable Kits**

- Self-limiting wattage heat cable prevents condensate drain from freezing in unconditioned areas
- Available in 6 or 24 ft. lengths

#### **Crawl Space Vent Drain Kit**

- Allows venting through a crawl space for downflow applications
- Includes 2 or 3 in. sanitary tee, 2 in. PVC assembly, PVC boot and clamp
- Kit for Canada is certified to ULC S636

#### **Downflow Combustible Flooring Base**

- Required for heating only units installed on combustible floors
- Not required in add-on cooling applications
- See Dimension Drawing

### **FILTER (not furnished)**

- Filter and provisions for external mounting must be field provided

### **Optional Accessories**

#### **Downflow Filter Cabinet**

- Filter cabinet mounts directly on top of furnace
- "B and "C" width cabinets have two filters
- Filter rails are furnished
- Front access for servicing
- Cleanable filter(s) are furnished



## SPECIFICATIONS

		Model No.	ML193DF045XE36B	ML193DF070XE36B	ML193DF090XE48C
<b>Gas Heating Performance</b>	AHRI Reference No.		20556884	20556885	20556886
	<sup>1</sup> AFUE		93%	93%	93%
	Input - Btuh		44,000	66,000	88,000
	Output - Btuh		42,000	63,000	84,000
	Temperature rise range - °F		30 - 60	40 - 70	45 - 75
	Gas Manifold Pressure (in. w.g.) Nat. Gas / LPG/Propane		3.5 / 10.0	3.5 / 10.0	3.5 / 10.0
	High static - in. w.g.		0.50	0.50	0.50
	<b>Connections in.</b>	Intake / Exhaust Pipe (PVC)		2 / 2	2 / 2
Gas pipe size IPS			1/2	1/2	1/2
Condensate Drain Trap (PVC pipe) - i.d.			3/4	3/4	3/4
with furnished 90° street elbow			3/4 slip x 3/4 Mipt	3/4 slip x 3/4 Mipt	3/4 slip x 3/4 Mipt
with field supplied (PVC coupling) - o.d.			3/4 slip x 3/4 MPT	3/4 slip x 3/4 MPT	3/4 slip x 3/4 MPT
<b>Indoor Blower</b>	Wheel nom. dia. x width - in.		10 x 8	10 x 8	10 x 10
	Motor output - hp		1/2	1/2	3/4
	Tons of add-on cooling		1.5 - 3	1.5 - 3	2.5 - 4
	Air Volume Range - cfm		335 - 1430	340 - 1415	825 - 1720
<b>Electrical Data</b>	Voltage	120 volts - 60 hertz - 1 phase			
	Blower motor full load amps		6.8	6.8	8.4
	Maximum overcurrent protection		15	15	15
<b>Shipping Data</b>	lbs. - 1 package		122	128	151

NOTE - Filters and provisions for mounting are not furnished and must be field provided.

<sup>1</sup> Annual Fuel Utilization Efficiency based on DOE test procedures and according to FTC labeling regulations. Isolated combustion system rating for non-weatherized furnaces.

## INSTALLATION CLEARANCES

Sides	<sup>1</sup> 0 inches (0 mm)
Rear	0 inches (0 mm)
Top/Plenum	1 inch (25 mm)
Front	0 inches (0 mm)
Front (service/alcove)	24 inches (610 mm)
Floor	<sup>2</sup> Combustible

NOTE - Air for combustion must conform to the methods outlined in the National Fuel Gas Code (NFPA 54/ANSI-Z223.1) or the National Standard of Canada CAN/CSA-B149.1 "Natural Gas and Propane Installation Code".

NOTE - In the U.S. flue sizing must conform to the methods outlined in the current National Fuel Gas Code (NFPA 54/ANSI-Z223.1) or applicable provisions of local building codes. In Canada flue sizing must conform to the methods outlined in National Standard of Canada CAN/CSA-B149.1.

<sup>1</sup> Allow proper clearances to accommodate condensate trap and vent pipe installation.

<sup>2</sup> Clearance for installation on combustible floor if Optional Downflow Combustible Flooring Base is installed between furnace and combustible floor. Not required in add-on cooling applications if installed in accordance with local codes or National Fuel Gas Code ANSI-Z223.1 or CAN/CGA-149.1,.2. Do not install the furnace directly on carpeting, tile, or other combustible materials other than wood flooring.



## OPTIONAL ACCESSORIES

		"B" Width Models	"C" Width Models	
<b>CABINET ACCESSORIES</b>				
Downflow Combustible Flooring Base		11M60	11M61	
<b>CONDENSATE DRAIN KITS</b>				
Condensate Drain Heat Cable	6 ft.	26K68	26K68	
	24 ft.	26K69	26K69	
Crawl Space Vent Drain Kit	US	51W18	51W18	
	Canada	15Z70	15Z70	
<b>CONTROLS</b>				
Blower Relay Kit (for two-stage outdoor units)		85W66	85W66	
iComfort® M30 Smart Wi-Fi Thermostat		15Z69	15Z69	
Remote Outdoor Temperature Sensor		X2658	X2658	
Twining Kit		16W72	16W72	
<b>DOWNFLOW FILTER KITS</b>				
<sup>1</sup> Downflow Filter Cabinet		51W07	51W08	
	No. and Size of filter - in.	(2) 16 x 20 x 1	(2) 16 x 20 x 1	
<b>NIGHT SERVICE KIT</b>				
Night Service Kit		84W48	84W48	
<b>TERMINATION KITS</b>				
See Installation Instructions for specific venting information.				
Direct Vent	Concentric	US - 2 in.	71M80	69M29
		3 in.	---	60L46
		Canada - 2 in.	44W92	44W92
		3 in.	---	44W93
Flush-Mount		US - 2, 2-1/2 or 3 in.	51W11	51W11
		Canada - 2, 2-1/2 or 3 in.	51W12	51W12
Wall - Close Couple		US - 2 in.	22G44	---
		3 in.	44J40	44J40
Wall - Close Couple WTK		Canada - 2 in.	30G28	---
		3 in.	81J20	81J20
Roof Termination Flashing Kit (no vent pipe - 2 flashings)		2 in.	15F75	15F75
		3 in.	44J41	44J41
<b>VENTING</b>				
Flue Coupling		2 in.	17H92	17H92

<sup>1</sup> Cleanable polyurethane frame type filter.

NOTE - Termination Kits (44W92, 44W93, 30G28, 51W12, 81J20) and Crawl Space Vent Drain Kit (15Z70) are certified to ULC S636 standard for use in Canada only.

## GAS HEAT ACCESSORIES

Models	High Altitude Pressure Switch Kit		Natural Gas to LPG/Propane Kit	LPG/Propane to Natural Gas Kit	Natural Gas High Altitude Orifice Kit	LPG/Propane High Altitude Orifice Kit	Muffler (US Only)
	4501 - 7500 ft.	7501 - 10,000 ft.	0 - 7500 ft.	0 - 7500 ft.	7501 - 10,000 ft.	7501 - 10,000 ft.	
045	11U65	11U66	11K49	73W81	73W37	11K44	15Y66 (2-inch)
070	11U65	11U66	11K49	73W81	73W37	11K44	15Y66 (2-inch)
090	11U65	11U66	11K49	73W81	73W37	11K44	15Y66 (2-inch)

## HIGH ALTITUDE DERATE

NOTE - Units may be installed at altitudes up to 10,000 ft.

At altitudes above 4501 ft. the unit must be derated to match the manifold pressure information shown below.

Units installed at altitudes of 4501 to 10,000 ft. require a pressure switch change.

Units installed at altitudes of 7501 to 10,000 ft. require an orifice change.

See the Gas Heat Accessories table for ordering information.

NOTE - This is the only permissible derate for these units.

NOTE - In Canada, certification for installations at elevations over 4500 feet is the jurisdiction of local authorities.

Input	Gas	Manifold Pressure in. w.g.					Supply Line Pressure in. w.g.	
		0 - 4500 ft.	4501 - 5500 ft.	5501 - 6500 ft.	6501 - 7500 ft.	7501 - 10,000 ft.	0 - 10,000 ft.	
All Sizes	Natural	3.5	3.3	3.2	3.1	3.5	4.5	13.0
	LPG/Propane	10.0	9.4	9.1	8.9	10.0	11.0	13.0

## VENT LENGTHS - UNINSULATED EXHAUST PIPE IN UNCONDITIONED SPACE

<sup>1</sup> Winter Design Temperatures	Vent Pipe Diameter	Unit Input Size					
		045		070		090	
		Maximum Uninsulated Exhaust Vent Length (ft.)					
		PVC	PolyPro InnoFlue	PVC	PolyPro InnoFlue	PVC	PolyPro InnoFlue
32 to 21°F	1-1/2 in.	25	N/A	25	N/A	N/A	N/A
	2 in.	18	16	31	28	50	48
	2-1/2 in.	13	N/A	24	N/A	42	N/A
	3 in.	9	9	18	18	35	35
20 to 1°F	1-1/2 in.	15	N/A	20	N/A	N/A	N/A
	2 in.	9	8	18	16	32	29
	2-1/2 in.	5	N/A	13	N/A	24	N/A
	3 in.	N/A	N/A	8	8	19	19
0 to -20°F	1-1/2 in.	10	N/A	15	N/A	N/A	N/A
	2 in.	5	N/A	12	10	22	19
	2-1/2 in.	N/A	N/A	7	N/A	15	N/A
	3 in.	N/A	N/A	N/A	N/A	10	10

NOTE - Concentric terminations are equivalent to 5 ft. of straight pipe and should be included when measuring total pipe length.

<sup>1</sup> Refer to 99% Minimum Design Temperature table provided in the current edition of the ASHRAE Handbook-Fundamentals.

PolyPro® poly-propylene vent pipe is a registered trademark of DuraVent®.

InnoFlue® is a registered trademark of Centrotherm Eco Systems.

## OUTDOOR TERMINATION KIT USAGE

Input Size	Vent Pipe Diameter (in.)	Standard Terminations				Concentric Terminations		
		Flush Mount Kit	Wall Kit		Field Fabricated Exhaust Accelerator Size Required	Concentric Kit		
			2 inch	3 inch		1-1/2 inch	2 inch	3 inch
			51W11 (US) 5 51W12 (CA)	22G44 (US) 5 30G28 (CA)		44J40 (US) 5 81J20 (CA)	71M80 (US) 5 44W92 (CA)	69M29 (US) 5 44W92 (CA)
045	1-1/2	4 YES	YES	2 YES	1-1/2 in.	3 YES	---	---
	2	4 YES	YES	2 YES	1-1/2 in.	3 YES	---	---
	2-1/2	4 YES	YES	2 YES	1-1/2 in.	3 YES	---	---
	3	4 YES	YES	2 YES	1-1/2 in.	3 YES	---	---
070	1-1/2	4 YES	YES	2 YES	1-1/2 in.	3 YES	---	---
	2	4 YES	YES	2 YES	1-1/2 in.	3 YES	---	---
	2-1/2	4 YES	YES	2 YES	1-1/2 in.	3 YES	---	---
	3	4 YES	YES	2 YES	1-1/2 in.	3 YES	---	---
090	2	4 YES	---	YES	2 in.	---	YES	YES
	2-1/2	4 YES	---	YES	2 in.	---	YES	YES
	3	4 YES	---	YES	2 in.	---	YES	YES

NOTE - Standard Terminations do not include any vent pipe or elbows external to the structure.

Any vent pipe or elbows external to the structure must be included in total vent length calculations. See Vent Length Tables.

<sup>1</sup> 2 inch to 1-1/2 inch reducer required, must be field provided.

<sup>2</sup> Requires field provided 1-1/2 in. outdoor exhaust accelerator.

<sup>3</sup> Concentric Kits **71M80** and **44W92** include 1-1/2 in. outdoor exhaust accelerator, required when used with 045 and 070 input models. Accelerator is not used with 090 input models. NOTE - When using 1-1/2 in. piping, the pipe must be transitioned to 2 in. pipe when used with the Concentric Kit.

<sup>4</sup> Flush Mount Kit **51W11** and **51W12** includes 1-1/2 in. outdoor exhaust accelerator, required when used with all models. NOTE - When using 1-1/2 in. piping, the pipe must be transitioned to 2 in. pipe when used with the Flush Mount Kit.

<sup>5</sup> Termination Kits **30G28**, **44W92**, **44W93**, **51W12** and **81J20** are certified to ULC S636 standard for use in Canada only.

## VENT LENGTHS

### STANDARD TERMINATION AT ELEVATION 0 - 10,000 ft.

	Pipe Size Input	1-1/2 in.			2 in.			2-1/2 in.			3 in.		
		045	070	090	045	070	090	045	070	090	045	070	090
No. of 90 ELL	1	20	15	N/A	61	46	24	100	80	43	127	127	108
	2	15	10	N/A	56	41	19	95	75	38	122	122	103
	3	10	N/A	N/A	51	36	14	90	70	33	117	117	98
	4	N/A	N/A	N/A	46	31	N/A	85	65	28	112	112	93
	5	N/A	N/A	N/A	41	26	N/A	80	60	23	107	107	88
	6	N/A	N/A	N/A	36	21	N/A	75	55	18	102	102	83
	7	N/A	N/A	N/A	31	16	N/A	70	50	13	97	97	78
	8	N/A	N/A	N/A	26	11	N/A	65	45	N/A	92	92	73
	9	N/A	N/A	N/A	21	N/A	N/A	60	40	N/A	87	87	68
	10	N/A	N/A	N/A	10	N/A	N/A	55	35	N/A	82	82	63

### CONCENTRIC TERMINATION ELEVATION 0 - 10,000 ft.

	Pipe Size Input	1-1/2 in.			2 in.			2-1/2 in.			3 in.		
		045	070	090	045	070	090	045	070	090	045	070	090
No. of 90 ELL	1	15	10	N/A	53	38	22	90	70	39	111	111	104
	2	10	N/A	N/A	48	33	17	85	65	34	106	106	99
	3	N/A	N/A	N/A	43	28	12	80	60	29	101	101	94
	4	N/A	N/A	N/A	38	23	N/A	75	55	24	96	96	89
	5	N/A	N/A	N/A	33	18	N/A	70	50	19	91	91	84
	6	N/A	N/A	N/A	28	13	N/A	65	45	14	86	86	79
	7	N/A	N/A	N/A	23	N/A	N/A	60	40	N/A	81	81	74
	8	N/A	N/A	N/A	18	N/A	N/A	55	35	N/A	76	76	69
	9	N/A	N/A	N/A	13	N/A	N/A	50	30	N/A	71	71	64
	10	N/A	N/A	N/A	N/A	N/A	N/A	45	25	N/A	66	66	59

NOTES - Additional vent pipe and elbows used to terminate vent pipe outside the structure must be included in the total vent length calculation.

Intake and exhaust pipes are sized separately.

Values in table are for separate intake or exhaust pipe lengths.

Both intake and exhaust pipe must be the same size diameter.

## VENT LENGTHS (EXHAUST) - VENTILATED ATTIC OR CRAWLSPACE INTAKE AIR - FEET

STANDARD TERMINATION AT ELEVATION 0 - 10,000 ft.

Pipe Size		1-1/2 in.			2 in.			2-1/2 in.			3 in.		
		045	070	090	045	070	090	045	070	090	045	070	090
<b>No. of 90 ELL</b>	1	15	10	N/A	51	36	14	85	65	28	107	107	88
	2	10	N/A	N/A	46	31	9	80	60	23	102	102	83
	3	N/A	N/A	N/A	41	26	4	75	55	18	97	97	78
	4	N/A	N/A	N/A	36	21	N/A	70	50	8	92	92	73
	5	N/A	N/A	N/A	31	16	N/A	65	45	3	87	87	68
	6	N/A	N/A	N/A	26	11	N/A	60	40	N/A	82	82	63
	7	N/A	N/A	N/A	21	6	N/A	55	35	N/A	77	77	58
	8	N/A	N/A	N/A	16	1	N/A	50	30	N/A	72	72	53
	9	N/A	N/A	N/A	11	N/A	N/A	45	25	N/A	67	67	48
	10	N/A	N/A	N/A	6	N/A	N/A	40	20	N/A	62	62	43

NOTES - Additional vent pipe and elbows used to terminate vent pipe outside the structure must be included in the total vent length calculation.

**DIMENSIONS - UNIT**

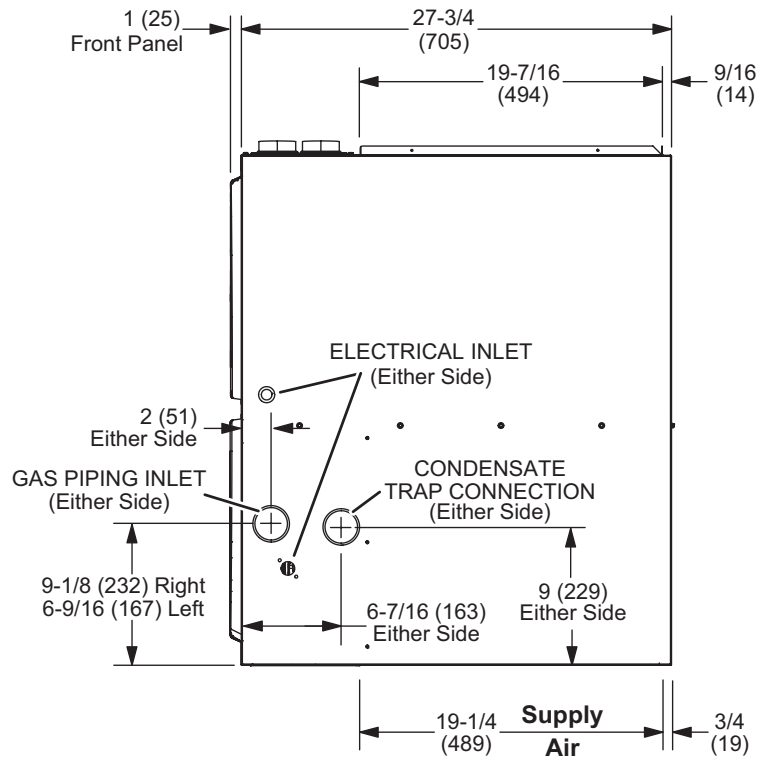
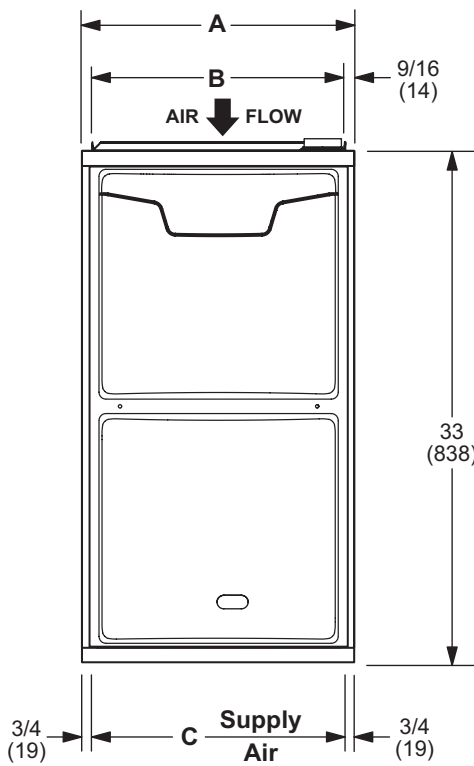
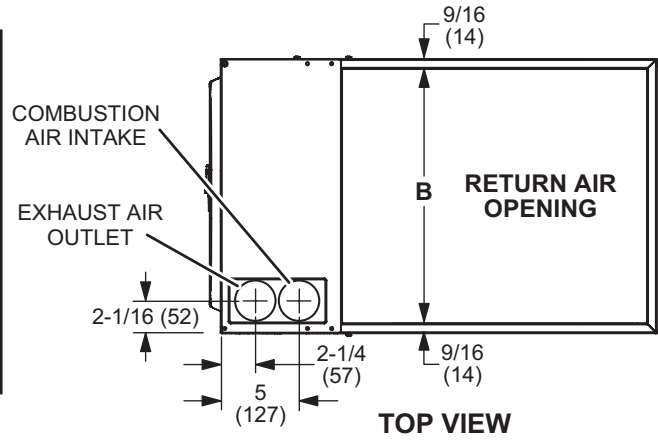
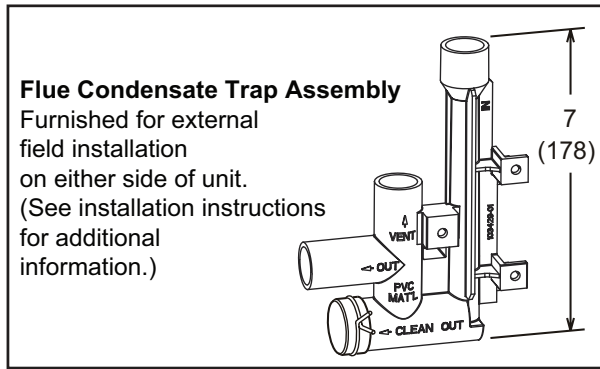

Model No.	A		B		C	
	in.	mm	in.	mm	in.	mm
ML193DF045XE36B ML193DF070XE36B	17-1/2	446	16-3/8	416	16	406
ML193DF090XE48C	21	533	19-7/8	505	19-1/2	495

DOWNFLOW FILTER CABINET

"B AND "C" WIDTH FURNACES  
(Two Filters)

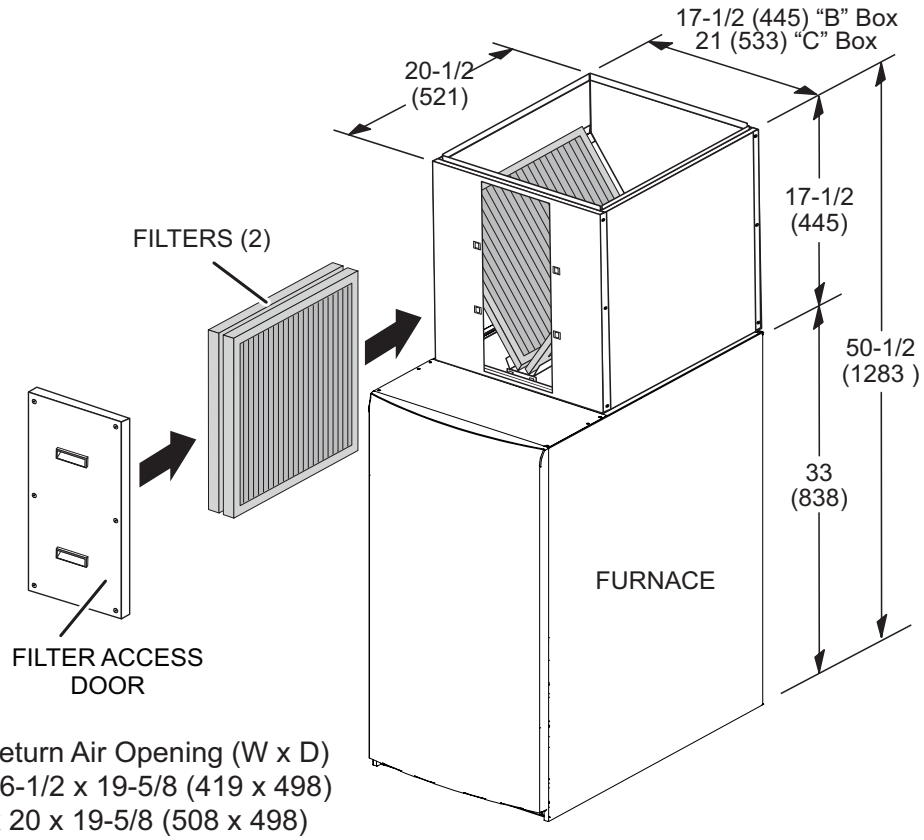

## DIMENSIONS - OPTIONAL ACCESSORIES

### DOWNFLOW COMBUSTIBLE FLOORING BASE

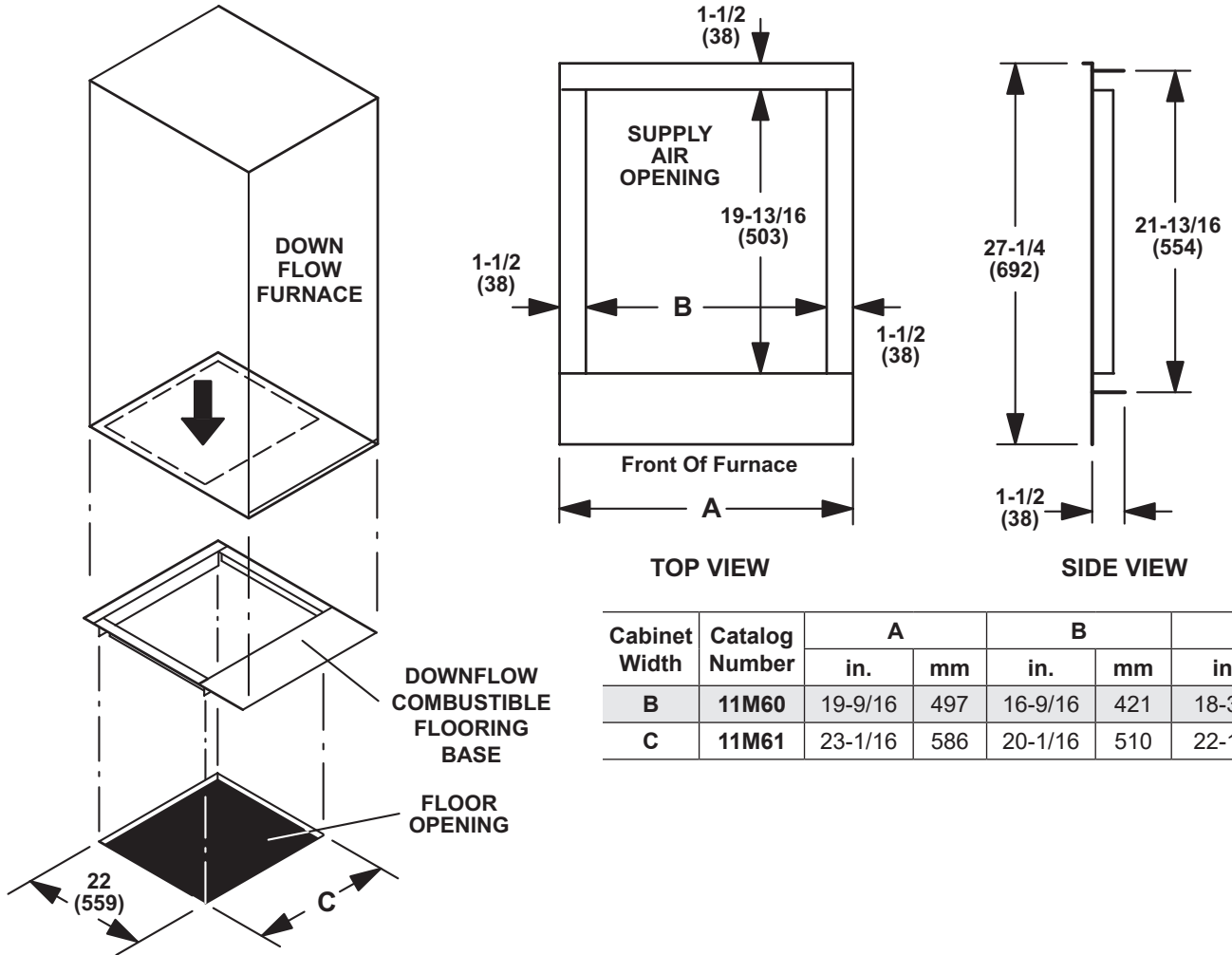

Cabinet Width	Catalog Number	A		B		C	
		in.	mm	in.	mm	in.	mm
B	11M60	19-9/16	497	16-9/16	421	18-3/4	476
C	11M61	23-1/16	586	20-1/16	510	22-1/4	565

## DIMENSIONS - FURNACE/COIL COMBINED DIMENSIONS

### DOWNFLOW POSITION

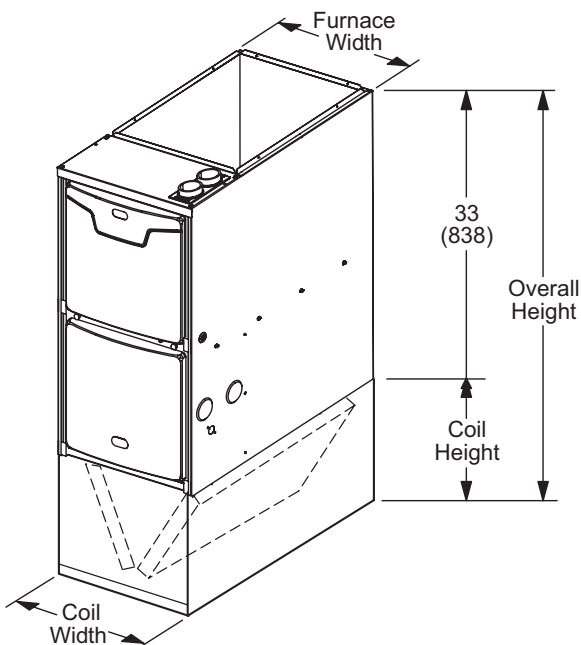

Model Number	Coil Width		Furnace Width		Coil Height		Overall Height	
	in.	mm	in.	mm	in.	mm	in.	mm
CR33-24B-F	17-1/2	446	17-1/2	446	13-1/4	337	46-1/4	1175
CR33-30/36B-F	17-1/2	446	17-1/2	446	16-1/8	410	49-1/8	1248
CR33-30/36C-F	21	533	21	533	16-1/8	410	49-1/8	1248
CR33-48B-F	21	533	17-1/2	446	20	508	53	1346
CR33-48C-F	21	533	21	533	20	508	53	1346
CR33-50/60C-F	24-1/2	622	21	533	23-5/8	600	56-5/8	2276



**DIMENSIONS - OPTIONAL ACCESSORIES - VENTING**

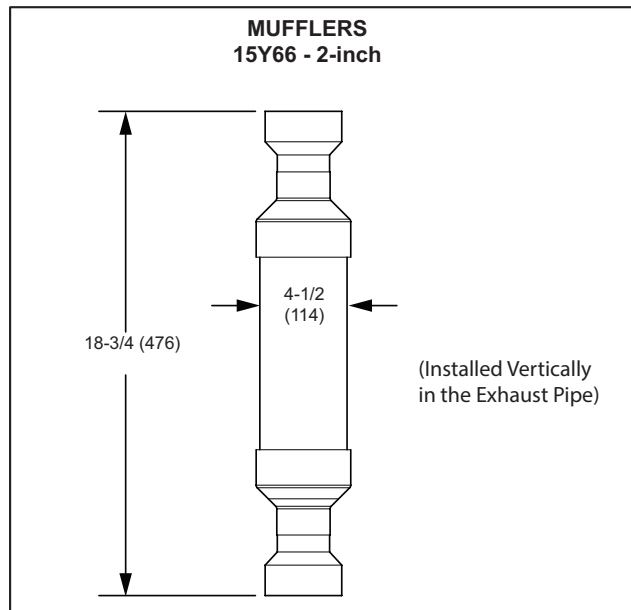
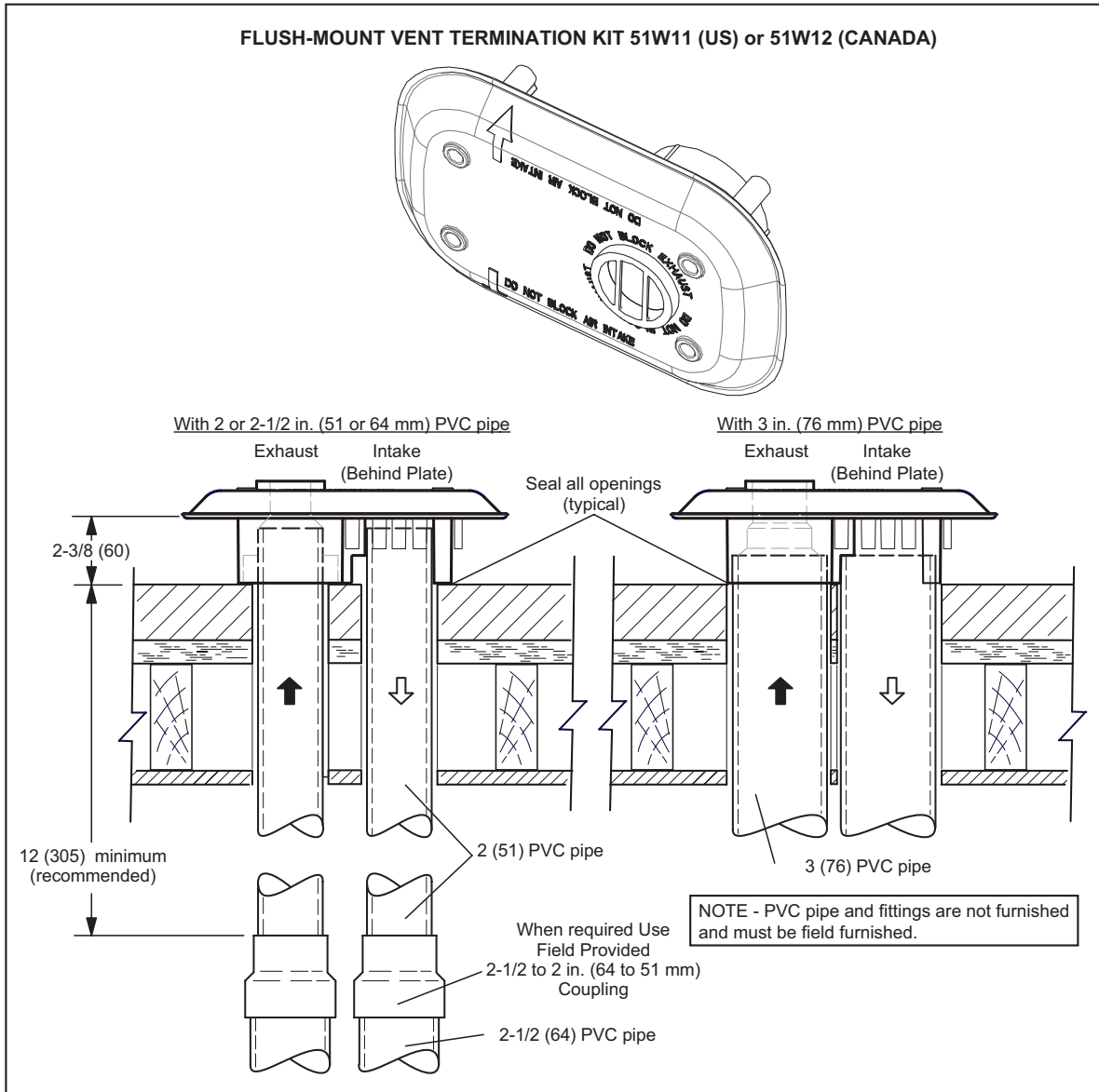

**CONCENTRIC WALL  
TERMINATION APPLICATIONS**

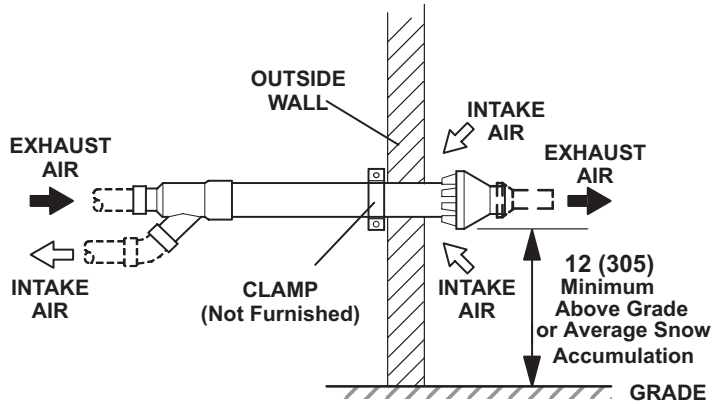

**CONCENTRIC ROOF  
TERMINATION APPLICATIONS**

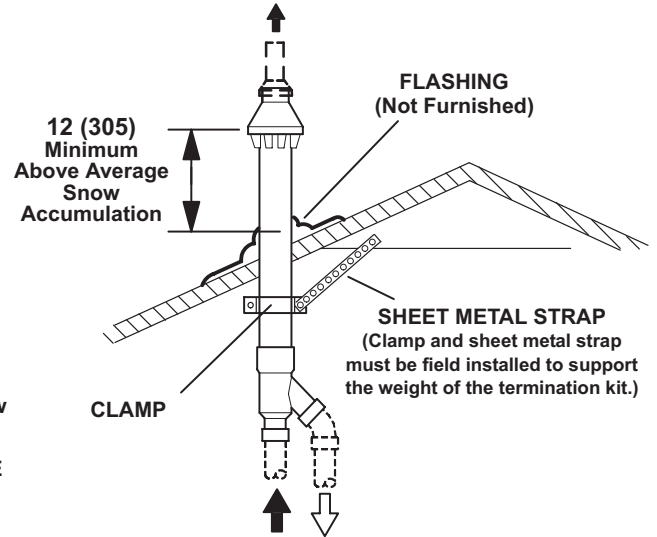

**71M80 / 69M29 / 44W92 – 2 inch kits  
60L46 / 44W93 – 3 inch kits**  
See Installation Instructions for additional information.

Note - Field provided reducer may be required to adapt different vent pipe sizes to termination.

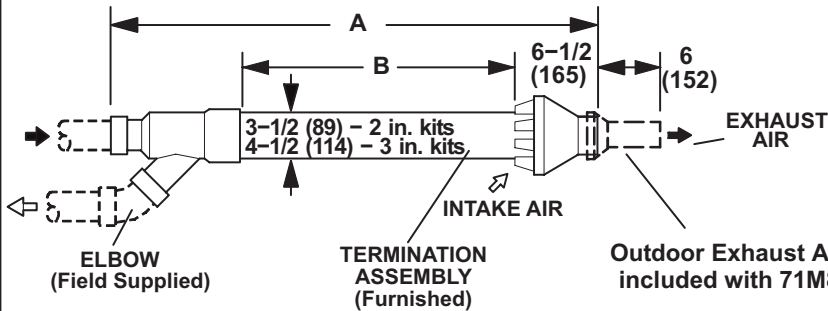

Cat. No.	A		B	
	in.	mm	in.	mm
71M80 69M29	33-3/8	848	16-3/4	425
44W92 (Canada)	29	737	15-1/2	394
60L46	38-7/8	987	21-3/16	538
44W93 (Canada)	36-1/8	918	19-1/2	495

**NOTE - Typical illustration for dimensions only. Design may vary depending on kit ordered.**

**WALL TERMINATION KITS (CLOSE-COUPLE)  
EXTENDED VENT FOR GRADE CLEARANCE  
2 inch (51 mm) 22G44 (US)  
3 inch (76 mm) 44J40 (US)**

**See Installation Instructions for additional information.**

Note - Field provided reducer may be required to adapt different vent pipe sizes to termination.

If Intake and Exhaust Pipe is less than 12 in. (305 mm) above snow accumulation or other obstructions, field fabricated piping must be installed.

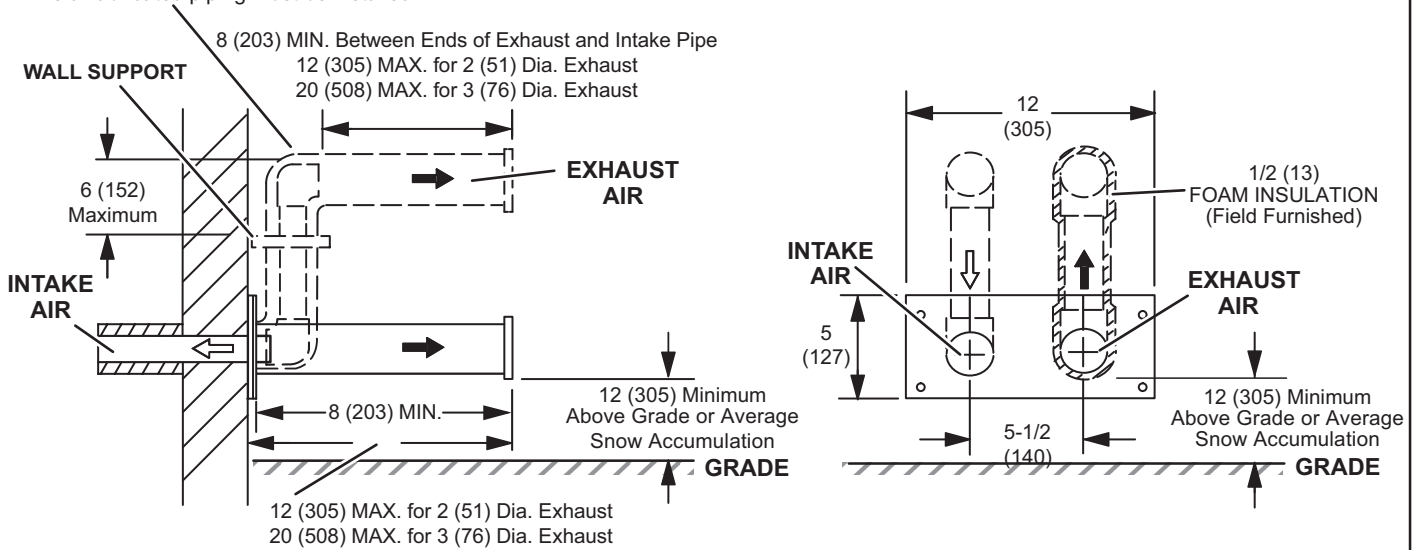

**WALL TERMINATION KITS (CLOSE-COUPLE)  
EXTENDED VENT FOR GRADE CLEARANCE  
2 inch (51 mm) 30G28 (WTK Canada)  
3 inch (76 mm) 81J20 (WTK Canada)**

**See Installation Instructions for additional information.**

Note - Field provided reducer may be required to adapt different vent pipe sizes to termination.

If Intake and Exhaust Pipe is less than 12 in. (305 mm) above snow accumulation or other obstructions, field fabricated piping must be installed.

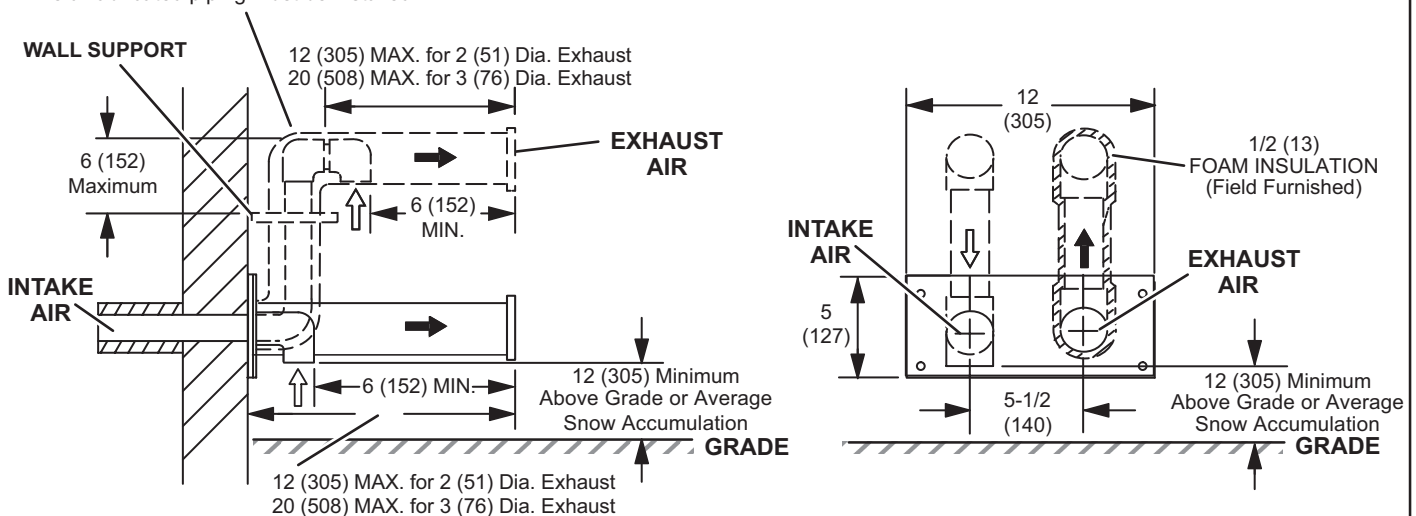

## BLOWER DATA

### ML193DF045XE36B PERFORMANCE (Less Filter)

External Static Pressure in. w.g.	Air Volume / Watts at Various Blower Speeds									
	High (Black)		Medium-High (Brown)		Medium (Blue)		Medium-Low (Yellow)		Low (Red)	
	cfm	Watts	cfm	Watts	cfm	Watts	cfm	Watts	cfm	Watts
0.00	1430	353	1305	270	1180	199	890	107	740	70
0.10	1395	364	1270	279	1145	207	845	113	695	76
0.20	1365	375	1245	291	1105	212	795	121	640	81
0.30	1330	383	1215	298	1070	221	740	126	575	86
0.40	1305	391	1180	310	1025	228	700	136	530	93
0.50	1275	400	1140	320	980	237	660	143	485	97
0.60	1245	406	1110	328	950	250	615	147	445	103
0.70	---	---	1080	335	910	252	585	151	390	107
0.80	---	---	1030	332	870	264	545	160	335	116

### ML193DF070XE36B PERFORMANCE (Less Filter)

External Static Pressure in. w.g.	Air Volume / Watts at Various Blower Speeds									
	High (Black)		Medium-High (Brown)		Medium (Blue)		Medium-Low (Yellow)		Low (Red)	
	cfm	Watts	cfm	Watts	cfm	Watts	cfm	Watts	cfm	Watts
0.00	1415	340	1295	269	1175	191	905	101	750	64
0.10	1380	351	1265	276	1140	202	860	109	700	73
0.20	1345	360	1240	285	1090	208	810	119	645	79
0.30	1325	371	1215	291	1060	218	770	124	590	84
0.40	1295	380	1175	302	1025	228	710	132	530	91
0.50	1260	392	1135	318	985	236	670	138	490	94
0.60	1235	402	1105	320	955	247	620	146	440	102
0.70	1185	411	1080	333	910	254	585	152	395	106
0.80	---	---	1040	342	865	261	540	157	340	113

### ML193DF090XE48C PERFORMANCE (Less Filter)

External Static Pressure in. w.g.	Air Volume / Watts at Various Blower Speeds									
	High (Black)		Medium-High (Brown)		Medium (Blue)		Medium-Low (Yellow)		Low (Red)	
	cfm	Watts	cfm	Watts	cfm	Watts	cfm	Watts	cfm	Watts
0.00	1720	412	1530	281	1400	220	1290	187	1195	146
0.10	1695	418	1495	288	1365	229	1265	194	1160	152
0.20	1680	431	1445	300	1315	240	1240	204	1110	159
0.30	1640	444	1410	309	1285	247	1200	214	1070	165
0.40	1605	455	1385	318	1245	255	1160	218	1020	171
0.50	1575	466	1355	325	1215	263	1115	227	975	179
0.60	1550	473	1310	334	1165	274	1085	232	925	188
0.70	1490	467	1265	346	1125	282	1030	243	885	195
0.80	---	---	1240	354	1075	288	995	251	825	202

## REVISIONS

Sections	Description of Change
Optional Accessories	Removed Wall Ring Kit (discontinued).



Visit us at [www.lennox.com](http://www.lennox.com)

For the latest technical information, [www.LennoxPros.com](http://www.LennoxPros.com)

Contact us at 1-800-4-LENNOX

NOTE - Due to Lennox' ongoing commitment to quality, Specifications, Ratings and Dimensions subject to change without notice and without incurring liability. Improper installation, adjustment, alteration, service or maintenance can cause property damage or personal injury. Installation and service must be performed by a qualified installer and servicing agency.

©2021 Lennox Industries, Inc.