

MINI-SPLIT SYSTEMS

MPB

Mini-Split

Multi-Zone Heat Pump Systems - R-410A - 60 Hz

Bulletin No. 210864
December 2020
Supersedes August 2019



**RESIDENTIAL / COMMERCIAL
PRODUCT SPECIFICATIONS**



MWMA Wall-Mounted
Non-Ducted Indoor Unit



M22A/M33A Cassette
Non-Ducted Indoor Unit



Wireless
Remote Controller
(furnished with
Wall-Mount,
Cassette, Console and
Ceiling/Floor
Non-Ducted Models)



MFMA Floor-Mount Console
Non-Ducted Indoor Unit



MCFA/MCFB Ceiling/Floor-Mount
Non-Ducted Indoor Unit



MMDB Medium Static Ducted Indoor Unit
with Wired Remote Controller (furnished)



MLB048 Heat Pump Outdoor Unit



MLA018 thru 036 Heat Pump Outdoor Units



ENERGY STAR

Certain models
have earned the
ENERGY STAR®
mark by meeting
strict energy
efficiency guidelines
set by the US EPA.

Up to 5 Zones

SEER - up to 23.00

HSPF - up to 11.5

1.5 to 4 Tons

Cooling Capacity - 17,500 to 48,000 Btuh

Heating Capacity - 18,200 to 49,000 Btuh

MODEL NUMBER IDENTIFICATION

OUTDOOR MULTI-ZONE HEAT PUMP UNITS

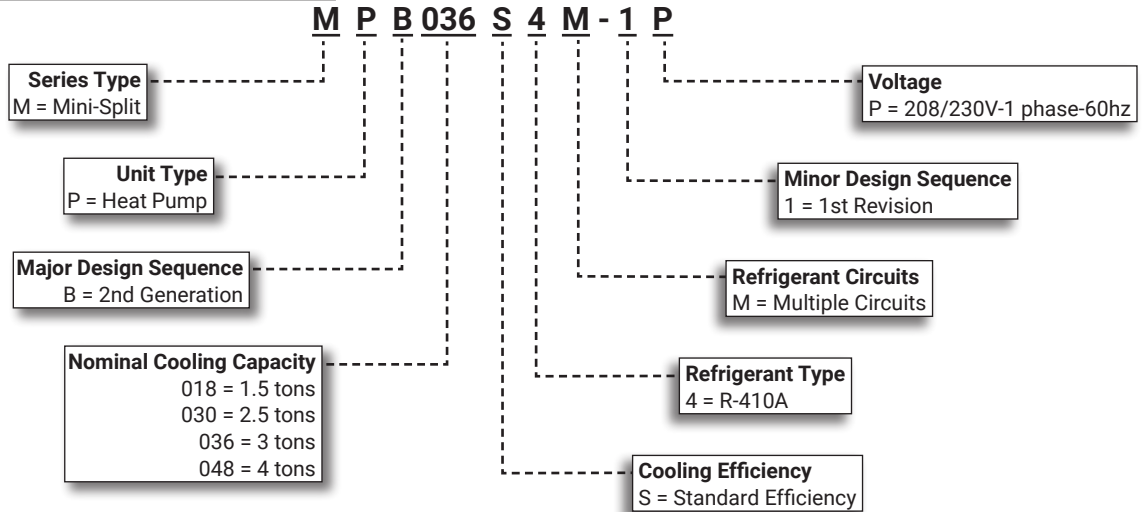

WALL-MOUNTED INDOOR UNITS

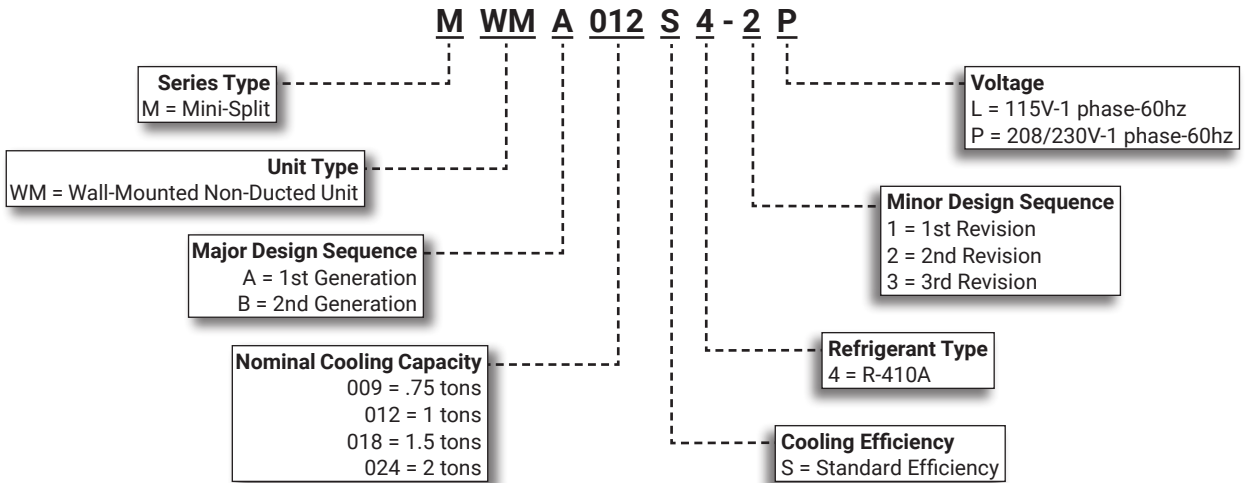

CASSETTE NON-DUCTED INDOOR UNITS

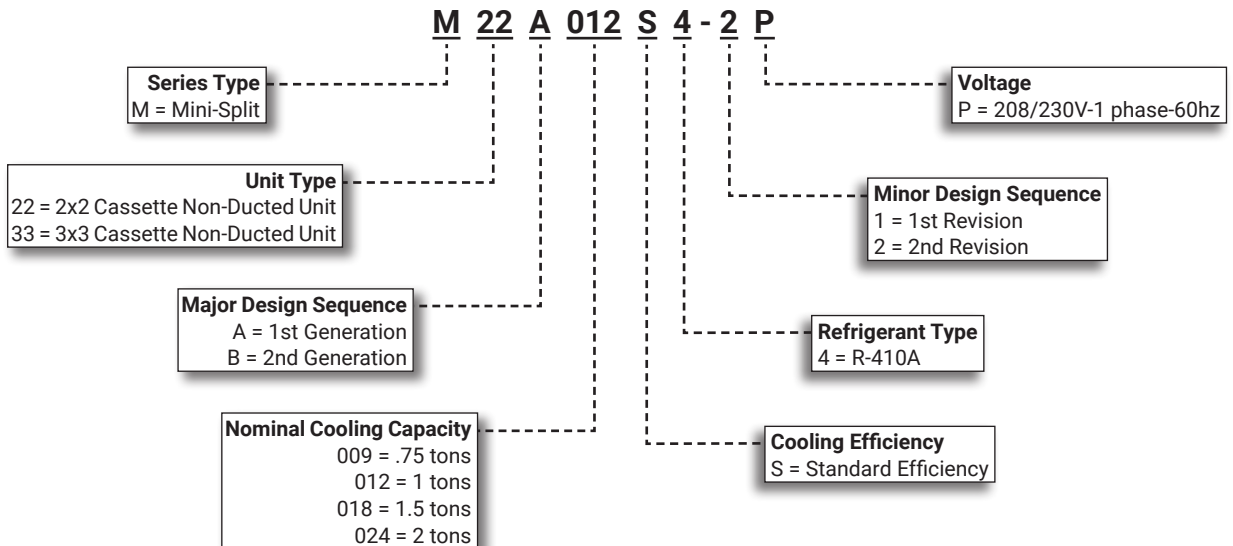

MODEL NUMBER IDENTIFICATION

CEILING/FLOOR NON-DUCTED INDOOR UNITS

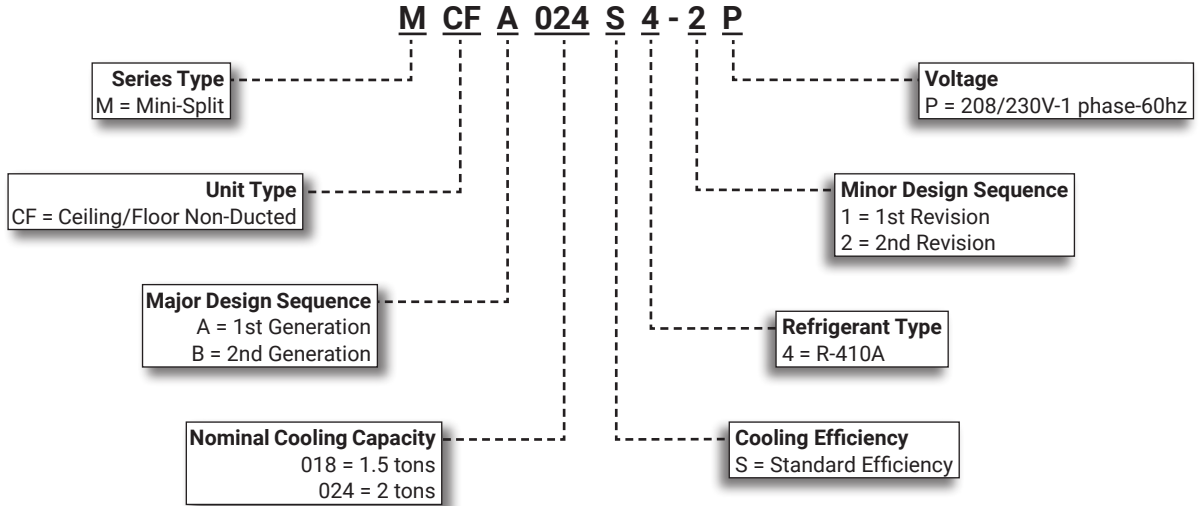

FLOOR-MOUNT CONSOLE NON-DUCTED INDOOR UNITS

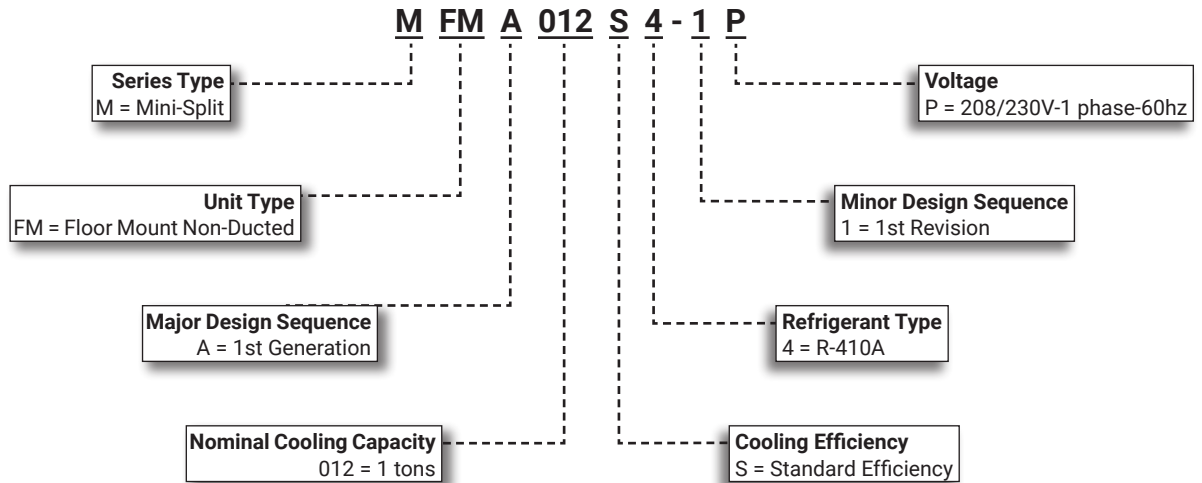

MEDIUM STATIC DUCTED INDOOR UNITS

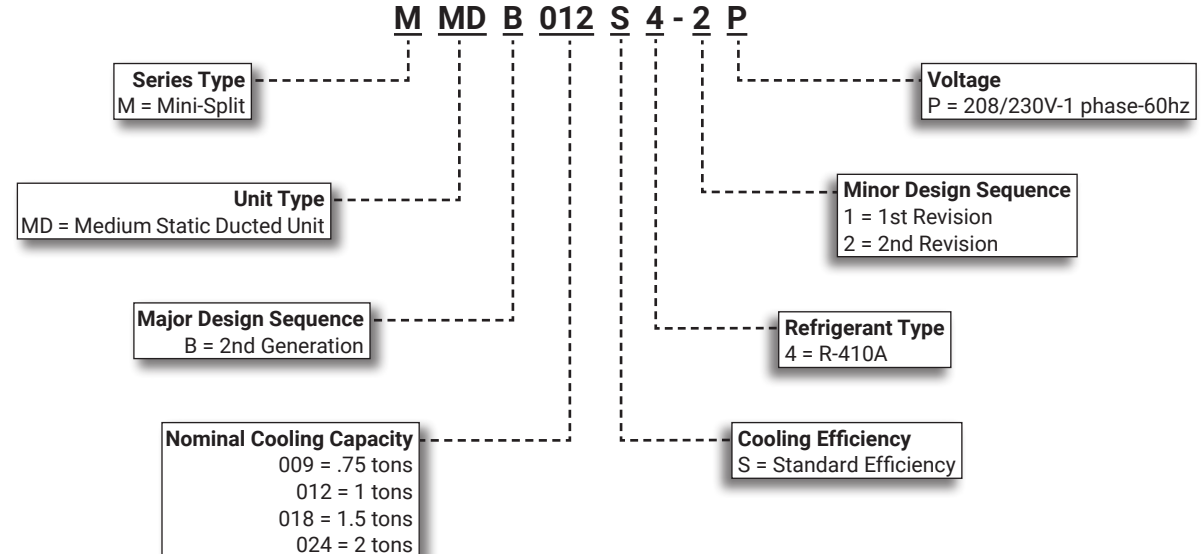

CONTENTS

AHRI Ratings	20
Accessories - Furnished	10
Air Throw Data.	33
- Cassette Indoor Units	34
- Ceiling/Floor Mount Indoor Units	35
- Wall-Mounted Indoor Units	33
Approvals And Warranty	5
Blower Data	36
- Medium Static Ducted Indoor Units	36
Connections And Line Set Usage	26
Dimensions	40
- Cassette Indoor Units	45
- Ceiling/Floor Mount Indoor Units	47
- Floor Mount Console Indoor Unit	47
- Medium Static Ducted Indoor Units	48
- Outdoor Units	40
- Wall-Mounted Indoor Units	43
- Wall-Mounted Indoor Units - Wall Plates	44
Features	5
- Indoor Units	7
- Outdoor Units	5
Installation Clearances	49
- Cassette Indoor Units	50
- Ceiling/Floor Mount Indoor Units	51
- Floor Mount Console Indoor Unit	52
- Medium Static Ducted Indoor Units	53
- Outdoor Units	49
- Wall-Mounted Indoor Units	50
Line Set And Elevation Guidelines	54
Model Number Identification.	2
Multi-Zone System Combinations	23
Optional Accessories - Order Separately	21
Sound Levels - Test Conditions	22
Specifications	16
- Cassette Indoor Units	18
- Ceiling/Floor Mount Indoor Units	19
- Floor Mount Console Indoor Units	19
- Medium Static Ducted Indoor Units	19
- MPB Outdoor Units - 1.5 Ton 2.5 Ton	16
- MPB Outdoor Units - 3 Ton 4 Ton	17
- Wall-Mounted Indoor Units	18

APPROVALS AND WARRANTY

APPROVALS

- AHRI Standard 210/240 certified with Addenda 1 and 2
- ENERGY STAR® certified (certain models)
- Rated According to U.S. Department of Energy (DOE) test procedures
- Indoor and outdoor units and components UL and CEC bonded for grounding to meet safety standards for servicing
- ETL certified for the U.S. and Canada
- Meets 2014 Florida Building Code Wind Design Criteria
 - Ultimate Wind Speed – 186 miles per hour
 - Risk Categories – III and IV
 - Wind Exposures – C and D
 - Mean Roof Heights – Up to 60 feet above ground

WARRANTY

- Compressor - Limited seven years
- All other covered components - Limited five years

NOTE - Refer to Lennox Equipment Limited Warranty certificate included with unit for specific details.

FEATURES

APPLICATIONS

- SEER - Up to 23.00
- HSPF - Up to 10.6.
- 1.5 through 4 ton
- Single phase power supply (208/230V)
- Outdoor unit sound levels as low as 62 dBA
- Indoor unit sound levels as low as 26.5 dBA
- Ductless mini-split systems provide a wide range of capacities and applications and provide an alternative when a ducted system is impractical or cost prohibitive
- Depending on capacity, multi-zone heat pumps allow up to five indoor units (5 zones) to be connected to one outdoor unit
- Units shipped completely factory assembled, internally piped, and wired

NOTE - Outdoor unit is designed for outdoor use.

NOTE - it is recommended that Medium Static Ducted Indoor Units not be installed in unconditioned spaces with temperatures above 100°F.

REFRIGERATION SYSTEM

R-410A Refrigerant

- Non-chlorine, ozone friendly
- Unit is factory pre-charged

Outdoor Coil

- Aluminum fins fitted to copper tubes
- Wire grille guard provided

Outdoor Fan

- Direct drive fan moves large air volumes uniformly through entire outdoor coil for high refrigeration capacity
- Fan guard provided

OUTDOOR UNITS

Refrigerant Line Connections, Service Valve

- Flare connection lines are located on side of unit cabinet
- Fully serviceable brass service valve prevents corrosion and provides access to refrigerant system

COMPRESSOR

Variable Frequency Rotary Compressor

- Compressor features high efficiency operation
- Balanced for reduced vibration and quiet operation
- Brushless DC motor uses powerful Neodymium magnets, which are approximately 15-20 times stronger than ferrite magnets used in conventional AC compressors

Compressor Crankcase Heater

- Protects against liquid refrigerant migration that can occur during low ambient operation

CONTROLS

DC Inverter Control

- Provides continuous operation, while adjusting capacity according to room temperature
- The accurate sensing of cooling loads prevents frequent changes in capacity and ensures efficient, economical operation

Inverter Module Protection

- Protects against differences in current, voltage and temperature
- Displays code on the indoor unit indicating a need for servicing

CONTROLS (continued)**Outdoor Unit Microprocessor**

- Electronic expansion valve control
- Automatic compressor timed-off protection (3 minutes)
- Temperature sensor
- LEDs on control display error codes and assist in troubleshooting
- 4-Way reversing valve control

Electronic Expansion Valve

- Furnished on all models

Compressor Overcurrent Protection

- Overcurrent protection can result due to any of the following:
 - Ambient temperature is too high
 - Locked rotor on the compressor
 - Outdoor air is blocked or restricted

Condenser High Temperature Protection

- Condenser high temperature can occur due to any of the following conditions:
 - High outdoor ambient
 - Outdoor fan blocked
 - Outdoor coil blocked
- The outdoor coil thermistor continuously monitors the temperature and communicates with the microprocessor
- Depending on the temperature measured, the compressor will be allowed to increase the frequency if needed to meet the load or is forced to run at the current or reduced frequency
- If the temperature becomes excessively high the compressor will be de-energized

Compressor Discharge Temperature Protection

- The compressor discharge line thermistor continuously monitors the temperature and communicates with the microprocessor
- Depending on the temperature measured, the compressor will be allowed to increase the frequency to meet the load or is forced to run at the current or reduced frequency
- If the temperature becomes excessively high, the compressor will be de-energized

Voltage Protection

- Protects unit from low or high voltage fluctuations

Terminal Strip

- Furnished for easy wiring connections

Automatic Piping/Wiring Correction

- Automatically checks piping/wiring connections
- A "Check Switch" on outdoor unit control reviews zone wiring and piping connections and displays "CE" if all connections are correct
- If a unit(s) is not connected to the correct zone the control will automatically remap the wiring to the correct zone based on indoor unit size

Defrost Control

- Defrost cycle is automatically enabled if there is a build-up of frost on the outdoor coil
- Outdoor fan operation is terminated during the defrost cycle
- Indoor fan changes to ultra low speed during the defrost cycle to help bring warm refrigerant back to the outdoor coil to assist during defrost operation
- Defrost LED is lit on the indoor unit panel on the front cover during a defrost cycle

Reversing Valve

- 4-way interchange reversing valve effects a rapid change in direction of refrigerant flow resulting in quick changeover from cooling to heating and vice versa
- Valve operates on pressure differential between outdoor unit and indoor unit of the system

CABINET

- Constructed of heavy gauge steel
- Tabs on unit base allow secure mounting to slab
- Condensate drain outlets furnished on unit base

NOTE - Drain must be field furnished.

- Pan heater prevents ice build-up in the bottom of the unit during heating operation
- Access cover for power and control wiring connections
- Access cover for service valves

WALL-MOUNTED INDOOR UNITS



- Low-sound, three-speed Wall Mount with LED display offers three access points for refrigerant outlet pipes: left, right or rear
- The front panel can be raised for accessible wiring and maintenance
- Swing louver angles to 90°
- Unit installs horizontally on a vertical wall
- **Pre-Heat Function** - Delays the operation of the fan until the indoor coil has reached a pre-determined temperature which prevents the discharge of cold air while the system is operating in the "heating" mode
- **LED Readout** - Mounted on unit. LED displays unit operation status, and codes for maintenance and servicing
- **Auto Restart** - Automatically restores the previous function setting if power is interrupted
- **Cooling Override** - Button on the indoor unit allows a temporary 30 minute override of the system for forced "AUTO" or "COOLING" operation
- **Flare Connections** - Equipped with liquid and gas flare fittings for quick and secure piping
- **Multi-Refrigerant Outlet** - Allows left, right, or rear access for refrigeration line connection
- **Three Speed Fan** - Fan functions at three speeds: low, medium and high
- **Air Filter** - Cleanable air filter is furnished as standard

CASSETTE INDOOR UNITS



- Low-sound and encased in galvanized steel, the Cassette unit with LED display offers 360° airflow for immediate, equal distribution of wide-range cooling and heating
- 360° Airflow Panel - Allows for even, wide-range cooling and heating
- Pre-Heat Function - Delays the operation of the fan until the indoor coil has reached a pre-determined temperature which prevents the discharge of cold air while the system is operating in the "heating" mode
- **LED Readout/Infrared Receiver Panel** - Mounted on unit. LEDs display unit operation status, and codes for maintenance and servicing
- Infrared receiver for use with wireless remote controller (furnished)
- **Auto Restart** - Automatically restores the previous function setting if power is interrupted
- **Cooling Override** - Button on the indoor unit allows a temporary 30 minute override of the system for forced "AUTO" or "COOLING" operation
- **Built-In Condensate Pump** - 27-1/2 in. maximum lift
- **Compact Design** - Allows accessible wiring and space-saving installation with reduced width and depth
- **Flare Connections** - Equipped with liquid and gas flare fittings for quick and secure piping
- **Three Speed Fan** - Fan functions at three speeds: low, medium and high
- **Turbo Fan With Backward Curved Blades** - Reduces sound levels and air resistance
- **Air Filter** - Cleanable air filter is furnished as standard



NOTE - The cassette panel must be ordered separately. See Specifications table for ordering information.

CEILING/FLOOR MOUNT INDOOR UNITS



- Low-sound, three-speed Ceiling and Floor Mount models with LED display has a multi-blade fan that distributes air vertically and horizontally with a wide angle sweeping motion
- Two installation options are available:
 1. Horizontally against the ceiling
 2. Vertically against the floor/wall
- **Pre-Heat Function** - Delays the operation of the fan until the indoor coil has reached a pre-determined temperature which prevents the discharge of cold air while the system is operating in the "heating" mode
- **LED Readout/Infrared Receiver Panel** - Mounted on unit. LEDs display unit operation status, and codes for maintenance and servicing
- Infrared receiver for use with wireless remote controller (furnished)



NOTE - Readout panel design varies depending on unit size.

- **Auto Restart** - Automatically restores the previous function setting if power is interrupted
- **Cooling Override** - Button on the indoor unit allows a temporary 30 minute override of the system for forced "AUTO" or "COOLING" operation
- **Flare Connections** - Equipped with liquid and gas flare fittings for quick and secure piping
- **Multi-Refrigerant Outlet** - Allows left, right, or rear access for refrigeration line connection
- **Three Speed Fan** - Fan functions at three speeds: low, medium and high
- **Air Filter** - Cleanable air filter is furnished as standard

FLOOR MOUNT CONSOLE INDOOR UNIT

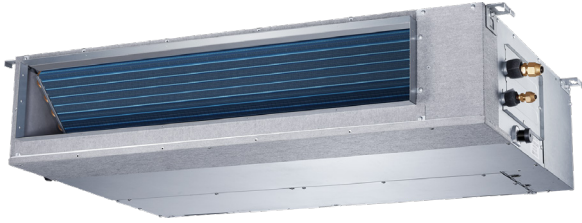

- Low-sound, three-speed Floor Mount Console model with LED display has a multi-blade fan that distributes air vertically and horizontally with a wide angle sweeping motion
- Installed vertically against the floor/wall
- Swing louver angles to 90°
- **Pre-Heat Function** - Delays the operation of the fan until the indoor coil has reached a pre-determined temperature which prevents the discharge of cold air while the system is operating in the "heating" mode
- **LED Readout/Infrared Receiver Panel** - Mounted on unit. LEDs display unit operation status, and codes for maintenance and servicing
- Infrared receiver for use with wireless remote controller (furnished)
- **Auto Restart** - Automatically restores the previous function setting if power is interrupted
- **Cooling Override** - Button on the indoor unit allows a temporary 30 minute override of the system for forced "AUTO" or "COOLING" operation
- **Flare Connections** - Equipped with liquid and gas flare fittings for quick and secure piping
- **Condensate Drain Connection** - Rear of unit
- **Condensate Flex Adaptor** - Flex adaptor and hose clamps are furnished for drain connection
- **Three Speed Fan** - Fan functions at three speeds: low, medium and high
- **Air Filter** - Cleanable air filter is furnished as standard
- **Hanging Brackets (2)** - Furnished for installation

MEDIUM STATIC DUCTED INDOOR UNITS

- Slim, compact design for limited space requirements. Installs out of sight between the drop ceiling and ceiling slab with ducted distribution to the indoor space
- **Pre-Heat Function** - Delays the operation of the fan until the indoor coil has reached a pre-determined temperature which prevents the discharge of cold air while the system is operating in the "heating" mode
- **LED Readout Panel** - Mounted in the unit control box unit. LEDs display unit operation status, and codes for maintenance and servicing
- **Auto Restart** - Automatically restores the previous function setting if power is interrupted
- **Cooling Override** - Button on the indoor unit allows a temporary 30 minute override of the system for forced "AUTO" or "COOLING" operation
- **Built-In Condensate Pump** - 27-1/2 inch lift
- **Duct Connections** - Return air connections can be made horizontally or from the bottom of the unit with interchangeable panel
- **Flare Connections** - Equipped with liquid and gas flare fittings for quick and secure piping
- **Three Speed Fan** - Fan functions at three speeds: low, medium and high
- **Air Filter** - Cleanable air filter is furnished as standard

AUTO CHANGEOVER OPERATION

- If an indoor unit in the system is set to "AUTO" mode the unit will operate in cooling, heating or fan mode based on temperature setting
- Fan runs in auto mode
- Each indoor unit has a "mode conflict priority" setting set by a DIP switch or from the remote controller (default setting is heating mode)
- The system "mode conflict priority" is set by the indoor unit connected through the "A" terminal strip
- If the "A" terminal strip is not used, the unit at the "B" terminal strip and any subsequent terminal strips is utilized (depending on number of zones/indoor units)
- When a mode conflict happens (all units are not set to the same mode), the indoor units with the mode equal to the system "mode conflict priority" will continue to operate
- The indoor unit with the different mode will be turned off and the display will show "--" indicating a mode conflict for that particular indoor unit
- Mode conflict will auto-reset once all units return to the same operating mode

ACCESSORIES - FURNISHED

WIRELESS REMOTE CONTROLLER

Furnished with Wall-Mount, Cassette, Floor Console and Ceiling/Floor Indoor Units.

- Complete remote control of system
- Maximum operating range is 25 ft.
- Operates on two AAA 1.5V batteries (furnished)
- Wireless remote controller holder furnished
- Holder can be mounted on a wall for easy access
- Mounting screws furnished

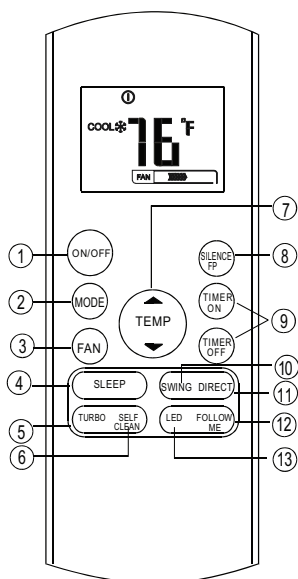

- 1 ON/OFF Button**
- Turns system on and off

- 2 MODE Button**
- Select system operation modes
 - Push button to cycle through each setting

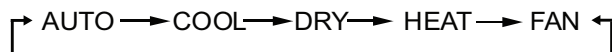

- 3 FAN Button**
- Select fan speed
 - Push button to cycle through each setting

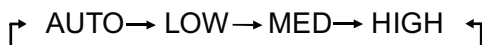

NOTE - Not available in AUTO or DRY modes.

- 4 SLEEP Button**
- Enables the system to automatically increase cooling or decrease heating (in 2°F increments) per hour for the first 2 hours, then maintain a steady temperature for 5 hours
 - System reverts back to previous operation mode after 7 total hours of operation

NOTE - To cancel, push the "MODE", "FAN SPEED" or "ON/OFF" buttons.

NOTE - SLEEP mode is only available when the unit is in COOL, HEAT or AUTO mode.

- 5 TURBO Button**
- Enables the unit to reach the preset temperature during cooling or heating operation in the shortest time

- 6 SELF CLEAN Button**
- Automatically cleans and dries the evaporator coil at the end of the cooling season, preventing any odors or mildew

- 7 UP/DOWN Buttons ▲ ▼**
- Increase or decrease the indoor temperature in one degree increments (maximum 86°F, minimum 62°F)

NOTE - Temperature cannot be adjusted in FAN mode.

NOTE - Press and hold and buttons together for 3 seconds to alternate the temperature display between the °C and °F scale.

- 8 SILENCE/FP Button**
- **Silence** - Operates the compressor at low frequency and low fan speed to reduce operating sound levels to a minimum
 - **FP** - Only available during heating operation - Unit will operate at a set temperature of 46°F

NOTE - To cancel, push the "ON/OFF", "SLEEP", "FP", "MODE", "FAN SPEED", "UP/DOWN" buttons.

- 9 TIMER ON / TIMER OFF Buttons**
- **TIMER ON** (initiates an auto-on time sequence)
 - **TIMER OFF** (initiates an auto-off time sequence)
 - Can be used separately or together
 - Each press of the button increases the time in 30 minute increments up to 10 hours
 - Above 10 hours each press of the button will increase the auto-timed setting by 60 minutes up to 24 hours

NOTE - To cancel, set timer to 0.0 or turn remote off and on.

- 10 SWING Button**
- Used to stop or start horizontal louver auto swing feature

- 11 DIRECT Button**
- Used to change the louver movement and set the desired up/down air flow direction
 - The louver angle changes 6° for each press of the button

- 12 FOLLOW ME Button**
- Allows remote temperature sensing of the room at the remote controller location

- 13 LED Button**
- Turns the LCD display backlight on the indoor unit on or off

ACCESSORIES - FURNISHED

WIRELESS REMOTE CONTROLLER OPERATION

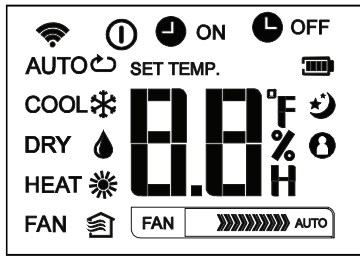

Mode display

AUTO COOL DRY
HEAT FAN

Displayed when data transmitted.
 Displayed when remote controller is ON.
 Battery display (low battery detection)

ON Displayed when TIMER ON time is set.
 OFF Displayed when TIMER OFF time is set.
 Show set temperature or room temperature, or time under TIMER setting.

Displayed in Sleep Mode operation.
 Indicated that the air conditioner is operating in Follow me mode

Fan speed indication

FAN Low speed
FAN Medium speed
FAN High speed
FAN AUTO Auto fan speed

Note - During unit operation only the active functions will be shown on the display.

Auto Operation

1. Press the **MODE** button to select Auto.
2. Press the **UP/DOWN** button to set the desired temperature.
3. Press the **ON/OFF** button to start the air conditioner.

Cooling /Heating/Fan Operation

1. Press the **MODE** button to select COOL, HEAT or FAN mode.
2. Press the **UP/DOWN** buttons to set the desired temperature.
3. Press the **FAN** button to select the fan speed in four steps- Auto, Low, Med, or High.
4. Press the **ON/OFF** button to start the air conditioner.

Dehumidifying Operation

1. Press the **MODE** button to select DRY mode.
2. Press the **UP/DOWN** buttons to set the desired temperature.
3. Press the **ON/OFF** button to start the air conditioner.

Timer ON/OFF Operation

1. Press the **TIMER ON** or **TIMER OFF** button. The remote controller shows **TIMER ON** or **TIMER OFF** icon, the previous Auto-on time setting and the signal "H" will be shown on the LCD display area.
2. Push the **TIMER ON** or **TIMER OFF** button again to set desired time. Each time you press the button, the time increases by 30 minutes between 0 and 10 hours and by 60 minutes between 10 and 24 hours.
3. After setting the **TIMER ON** or **TIMER OFF** there will be a one second delay before the remote controller transmits the signal to the unit. After approximately 2 seconds, the signal "H" will disappear and the set temperature will re-appear on the LCD display window.

ACCESSORIES - FURNISHED

WIRED REMOTE CONTROLLER

Furnished with Ducted Indoor Units.

NOTE - Can be ordered separately for non-ducted indoor units.

FEATURES

- Permanent Memory - Maintains clock, fan speed and mode of operation settings following power outages
- Dimensions (H x W x D) - 4-3/4 x 4-3/4 x 7/8 in.
- Additional hardware is furnished for installation
- Wiring - Controller uses 5-wire shielded 20 ft. (6 m) cable (furnished) for easy low voltage connection to the indoor unit
- Maximum cable length is 40 ft. (12 m)



DISPLAY

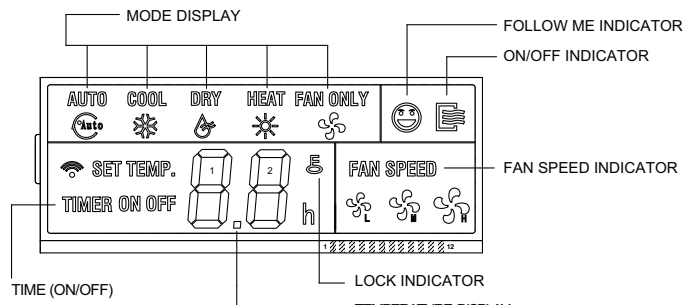

BUTTONS AND FUNCTIONS

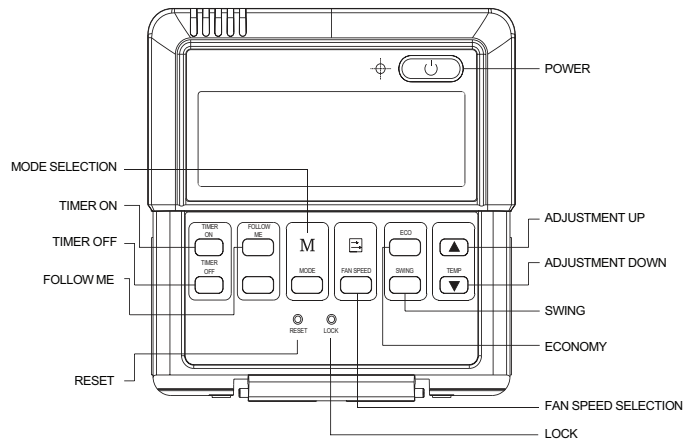

MODE Button

- Select system operation modes. Push button to cycle through each setting



POWER Button

- Turns system on and off

FAN SPEED Button

- Selects fan speed. Each button press cycles through the following settings on display

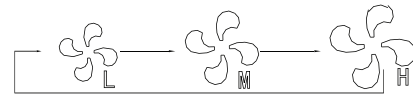

NOTE - Not available in AUTO mode.

TIMER ON / TIMER OFF Buttons

- TIMER ON (initiates an auto-on time sequence)
- TIMER OFF (initiates an auto-off time sequence) can be used separately or together
- Each press of the button increases the time in 30 minute increments up to 10 hours
- Above 10 hours each press of the button will increase the auto-timed setting by 60 minutes up to 24 hours

NOTE - To cancel, set timer to 0.0.

UP/DOWN Buttons ▲ ▼

- Increase or decrease the indoor temperature in two degree increments (maximum 88°F, minimum 62°F).

NOTE - Temperature cannot be adjusted in FAN mode.

NOTE - Press and hold and buttons together for 3 seconds to alternate the temperature display between the °C and °F scale.

SWING Button

- Used to stop or start horizontal louver auto swing feature

ECONOMY Button

- Maintains the most comfortable temperature and saves energy

RESET Button (Recessed)

- Resets Controller to factory settings. Recessed to prevent tampering

LOCK Button (Recessed)

- Locks Controller buttons to prevent tampering with settings

OPTIONAL ACCESSORIES

Extension Cable for Wired Remote Controller

- 20 ft. cable for easy low voltage connection to the indoor unit
- Extends cable to maximum 40 ft. length

OPTIONAL ACCESSORIES - ORDER SEPARATELY

WIRED PROGRAMMABLE CONTROLLER

M0STAT64Q-1



- Wired programmable local controller for mini-split indoor units with convenient timed schedules for daily operation
- Up to 8 events per day
- Schedule start time, mode, setpoint, and fan speed
- Compatible with all indoor units
- Copy/paste function for easy duplication of events to other days
- Built-in system diagnostics
- Large, back-lit, easy-to-read LCD screen with digital display

BUTTONS AND FUNCTIONS

POWER Button

- Turn system on and off

FAN SPEED Button

- Scroll through fan speeds (Auto - Low - Med - High)

MODE Button

- Use + and – buttons to scroll through available operation modes (Auto / Cool / Dry / Fan / Heat)

PLUS (+) and MINUS (-) Buttons

- Setpoint adjustment (62-86°F)
- Select days of the week when setting a schedule
- Select mode of operation

SWING Button

- Stop or start horizontal (up/down) louver auto swing
- Controls swing oscillation and louver angle in 6° increments

TIMER Button

- Sets current time of day (24 hour clock)
- Setup weekly schedules or to setup timed operation for the indoor unit
- Stop/Stop timed operation

DAY OFF / DEL Button

- Disable specific days/schedules of the week
- Delete a specific event

CONFIRM Button

- Confirms each step when managing schedules

BACK/TURBO Button

- Turbo sets indoor unit fan speed to high for a factory-set time period

COPY/FOLLOW ME Button

- Toggles between room temperature sensing from the indoor unit or the controller

DISPLAY

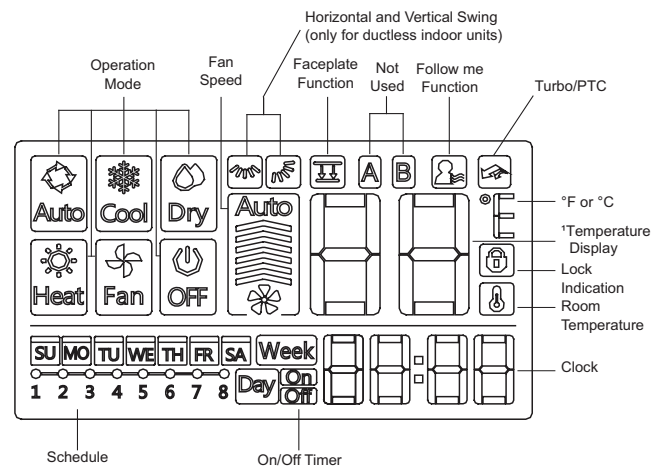

¹ Displays cooling setpoint, heating setpoint or room temperature

- Audible tone when a button is pressed (can be disabled)
- Lock function disables buttons to prevent tampering
- Controller uses 4-wire shielded 20 ft. (6 m) cable (furnished) for easy low voltage connection to the indoor unit
- Adaptor cables are furnished for various indoor unit connections

NOTE - Cable for longer lengths must be ordered separately.

NOTE - Maximum cable length is 164 ft. (50 m).

- Hardware for mounting furnished
- Mounts to standard electrical junction box (not furnished)
- Lithium battery furnished
- Power Supply: 5 VDC
- Dimensions (H x W x D): 4-7/8 x 4-3/4 x 3/4 in. (124 x 121 x 19 mm)

OPTIONAL ACCESSORIES

Extension Cable for Wired Programmable Controller

- 20 ft. cable for easy low voltage connection to the indoor unit
- Extends cable to 40 ft. (12 m) length

OPTIONAL ACCESSORIES - ORDER SEPARATELY

OUTDOOR UNITS

Condenser Pad

- Provides permanent foundation for outdoor units
- One-piece lightweight structural foam and molded from high-density polyethylene (HDPE)
- Lightweight, easy to carry and install
- Textured finish provides a non-skid surface so outdoor unit sits securely in one place
- UV stable

Disconnects

- Positive unit disconnect
- Single door enclosure
- Fused and non-fused models available

Fuses

- 30 and 60 amp fuses available

Hail Guards

- Protects outdoor coils on all sides without inhibiting airflow or performance
- Self-tapping screws provided for installation
- Flat shape allows for outdoor units to be placed close together
- Each kit contains all required guards
- Order one hail guard kit per outdoor unit module

Indoor/Outdoor Wiring Cable

- 14-gauge, 4-conductor wire
- THHN (Thermoplastic High Heat-resistant Nylon-coated) wire
- Suitable for wet or dry locations
- Rated up to 600V

Refrigerant Line Sets

- Refrigerant lines are shipped refrigeration clean
- Lines are cleaned, dried, pressurized and sealed at factory

Wall Brackets

- Heavy duty 1/8 in. thick steel brackets for supporting outdoor units
- Mount at any height to allow for easy maintenance under units
- Pre-punched holes for easy installation
- Powder coated gray finish
- Load rating 600 lbs. per pair

Whips

- Heavy duty electrical whips are available in 8 and 10 gauge sizes
- 6 ft. lengths
- Weatherproof metal conduit

INDOOR UNITS

Condensate Pumps

- Quietly and efficiently removes condensate
- See Optional Accessories Table for available pumps

A/C Easy Tee® Condensate Cleanout

- Condensate drain service port
- Flexible and easy to use with nitrogen, water or shop vac
- Screw cap on top allows easy access to condensate drain line

SPEEDICHANNEL™ SYSTEM



- SpeediChannel™ is a channel system covers system line sets
- Two-part system has a base and a cover
- Base is fastened to a wall or ceiling with plastic clips (SpeediClip™) that snap into a channel already molded into the base
- Cover fits on top of the base
- Manufactured from rigid PVC, which is UL rated and resistant to UV light
- System is a natural color that closely matches typical mini-split outdoor units
- Can be painted as desired to match any wall color

Typical Application

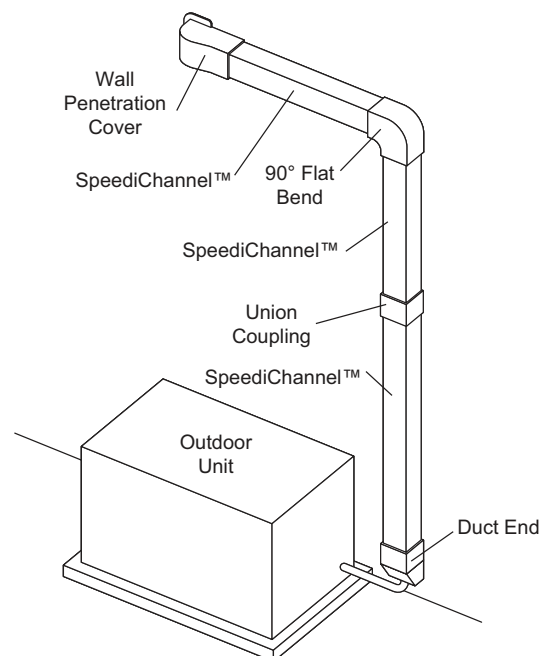

OPTIONAL ACCESSORIES - ORDER SEPARATELY

SPEEDICHANNEL™ SYSTEM (continued)

SpeediChannel™ Starter Kit

- The starter kit includes (1) Coupling, (1) Wall Penetration, (1) Inside Elbow, (1) Long Radius Flat Bend, (10) Speediclips™, (10) 11 in. Cable Ties, and (1) SpeediChannel Instruction Booklet

Duct End

- Duct Ends are used to terminate a run of SpeediChannel™ to a small opening just large enough for the line set and condensate drain line to pass through



Flat Wall Escutcheon

- Flat Wall Escutcheons are used to cover a rough opening in a soffit, wall, or ceiling penetration



- One side of the escutcheon is flat to allow for a SpeediChannel™ to run along a wall and to penetrate through an adjacent wall or ceiling
- This is the most common type of wall penetration
- Furnished in two parts, the escutcheon easily snaps onto the SpeediChannel™

Flex Joint

- A Flex Joint is an accordion-style piece of SpeediChannel™
- The flex joint can be extremely flexible when routing a SpeediChannel™ system around an obstacle
- Each joint is 20 in. long and can be combined together for longer flex runs
- The flex joint does not require the use of a union coupling
- The flex joint slides tightly inside the SpeediChannel™ system

T-Joint

- T-Joints are used for creating a tee connection between three pieces of SpeediChannel™
- Each tee is individually packed and furnished with stainless steel screws

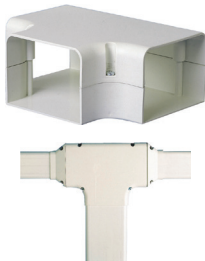

Union Coupling

- Union Couplings are used for joining two pieces of SpeediChannel™
- Each coupling is individually packed and furnished with stainless steel screws



Wall Penetration Cover

- Wall penetration covers are used to transition from the SpeediChannel™ system to a through wall penetration
- Wall covers are designed to allow for easy installation, even after the line set has been installed
- A hooking and fastening arrangement allows for quick installation
- Each wall cover is individually packed, and furnished with stainless steel screws to attach the wall cover to the base
- Three screws are necessary to fasten the wall cover to the wall construction, regardless of the type of installed system



45° and 90° Flat Bend Elbows

- 45° Flat Bends are used to route the SpeediChannel™ around obstacles
- Each bend is individually packed and furnished with stainless steel screws



45°



90°

90° Inside Elbow

- 90° Inside Elbows are used to route the SpeediChannel™ around an inside corner
- Each elbow is individually packed and furnished with stainless steel screws

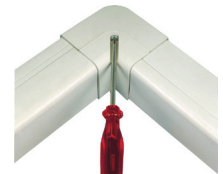

Mount Block White Qty. (2) 14 in. and (2) 36 in.

- Mount Blocks are used as mounting bases when outdoor units must be bolted down
- End caps (for aesthetics) come furnished with mounting bolts
- Maximum load capacity is 900 pounds per mounting block
- Installation temperatures range from -4°F to 140°F
- Mount blocks fit all mini-split outdoor units with a sliding rail feature



SPECIFICATIONS **MPB OUTDOOR UNITS - 1.5 TON | 2.5 TON**

Nominal Size - Tons		1.5	2.5
Outdoor Unit Model No.		MPB018S4M	MPB030S4M
Number of Zones		2	Up to 3
Ambient Temperature Range - °F	Cooling	-13 - 122	-13 - 122
	Heating	-13 - 86	-13 - 86
Sound Data (dBA)	Cooling	62	63
	Heating	62	63
Refrigerant	Charge furnished (R-410A)	4 lbs. 7 oz.	6 lbs. 3 oz.
Maximum line length with furnished charge (per zone) - ft.		25	25
Additional charge required per ft. - oz.		0.16	0.16
Compressor	No. and Type	(1) Rotary	(1) Rotary
	Refrigerant oil type	VG74	VG74
	Refrigerant oil charge - oz.	16.9	22.7
Connections	Liquid+Gas pipe (in.) flare	(2) 1/4 + (2) 3/8	(3) 1/4 + (3) 3/8
	Max pipe. length for all rooms - ft.	131	197
	Max. pipe length for one indoor unit - ft.	82	98
	Max. height difference between indoor and outdoor units - ft.	49	49
	Max. height difference between indoor units - ft.	33	33
Outdoor Fan	(No.) Diameter - in.	(1) 19	(1) 20
	Total air volume - cfm	1390	2130
	Motor rpm	150/200/250/300/350/450/550/650/ 800/850	150/200/250/300/400/500/600/750/ 900/1000
Outdoor Coil	Number of rows	2	2
	Fins per inch	18	17
	Fin type	Hydrophilic Aluminum	
	Tube outside diameter - in.	3/8	3/8
	Tube type	Rifled Copper Tubing	
	Net face area - ft. ²	5.19	8.24
Application area - sq. ft.		260 - 375	430 - 630
Design Pressure	PSIG	550/340	550/340
Shipping Data	Net/Shipping weight (lbs.)	106 / 115	150 / 161
ELECTRICAL DATA			
Electrical Characteristics - 60 Hz - 1 Phase		208/230V	208/230V
¹ Maximum Overcurrent Protection (amps)		25	35
² Minimum circuit ampacity		18	25
Compressor Rated load amps		10	20
Outdoor Fan Motor	Rated load amps	0.74	0.9
	Output - W	50	120

NOTE - Extremes of operating range are plus and minus 10% of line voltage.

¹ HACR type circuit breaker or fuse.

² Refer to National or Canadian Electrical Code manual to determine wire, fuse and disconnect size requirements.

NOTE - Adaptors are furnished for the gas pipe connections:

018 - (2) 3/8 x 1/2 in.

030 - (3) 3/8 x 1/2 in.

SPECIFICATIONS **MPB OUTDOOR UNITS - 3 TON | 4 TON**

Nominal Size - Tons		3	4
Outdoor Unit Model No.		MPB036S4M	MPB048S4M
Number of Zones		Up to 4	Up to 5
Ambient Temperature Range - °F	Cooling	-13 - 122	-13 - 122
	Heating	-13 - 86	-13 - 86
Sound Data (dBA)	Cooling	62	64
	Heating	62	64
Refrigerant	Charge furnished (R-410A)	6 lbs. 10 oz.	10 lbs. 2 oz.
Maximum line length with furnished charge (per zone) - ft.		25	25
Additional charge required per ft. - oz.		0.16	0.32
Compressor	No. and Type	(1) Rotary	(1) Twin Rotary
	Refrigerant oil type	VG74	VG74
	Refrigerant oil charge - oz.	33.8	47.3
Connections	Liquid+Gas+Gas pipe (in.) flare	(4) 1/4 + (3) 3/8 + (1) 1/2	(5) 1/4 + (3) 3/8 + (2) 1/2
	Max pipe. length for all rooms - ft.	262	262
	Max. pipe length for one indoor unit - ft.	115	115
	Max. height difference between indoor and outdoor units - ft.	49	49
	Max. height difference between indoor units - ft.	33	33
Outdoor Fan	(No.) Diameter - in.	(1) 20	(2) 22
	Total air volume - cfm	2130	4500
	Motor rpm	150/200/250/300/400/500/600/750/ 900/1000	150/200/250/300/400/500/600/700/ 800/870
Outdoor Coil	Number of rows	2	2
	Fins per inch	19	18
	Fin type	Hydrophilic Aluminum	
	Tube outside diameter - in.	3/8	3/8
	Tube type	Rifled Copper Tubing	
	Net face area - ft. ²	8.16	6.43 (inner coil) / 6.97 (outer coil)
Application area - sq. ft.		515 - 755	690 - 1010
Design Pressure	PSIG	550/340	550/340
Shipping Data	Net/Shipping weight (lbs.)	157 / 168	224 / 255
ELECTRICAL DATA			
Electrical Characteristics - 60 Hz - 1 Phase		208/230V	208/230V
¹ Maximum Overcurrent Protection (amps)		45	50
² Minimum circuit ampacity		30	35
Compressor Rated load amps		19	21
Outdoor Fan Motor	Rated load amps	1.3	(2) 0.39
	Output - W	120	(2) 85

NOTE - Extremes of operating range are plus and minus 10% of line voltage.

¹ HACR type circuit breaker or fuse.

² Refer to National or Canadian Electrical Code manual to determine wire, fuse and disconnect size requirements.

NOTE - Adaptors are furnished for the gas pipe connections:

036 - (3) 3/8 x 1/2 in. and (1) 1/2 x 3/8 in.

048 - (3) 3/8 x 1/2 in., (2) 1/2 x 3/8 in., (2) 1/4 x 3/8 in. and (2) 1/2 x 5/8 in.

SPECIFICATIONS
WALL-MOUNTED INDOOR UNITS

		Model No.	MWMA009S4	MWMA012S4	MWMA018S4	MWMA024S4
		Nominal Tons	0.75	1	1.5	2
Power Supply - 60 hz - 1 phase		208/230V	208/230V	208/230V	208/230V	
Rated load amps		0.2	0.2	0.4	0.5	
Output (W)		20	20	58	60	
Room Temperature Range (°F)	Cooling	62 - 90	62 - 90	62 - 90	62 - 90	
	Heating	32 - 86	32 - 86	32 - 86	32 - 86	
Air Volume - cfm (High/Medium/Low)		370/270/195	370/275/200	530/410/295	695/625/485	
Sound Data (dBA) - Low/Medium/High		26.5/33.4/41.7	28.6/35.8/45.1	30.9/36.3/46.2	35.1/44.5/51.7	
Piping Connections - Liquid/Gas - o.d. - flare - in.		1/4 / 3/8	1/4 / 1/2	1/4 / 1/2	3/8 / 5/8	
Drain connection o.d. - in.		1	1	1	1	
Net/Shipping weights - lbs.		20 / 26	20 / 27	27 / 35	40 / 54	

SPECIFICATIONS
CASSETTE INDOOR UNITS

		Model No.	M22A009S4	M22A012S4	M22A018S4	M33A024S4
		Nominal Tons	0.75	1	1.5	2
Power Supply - 60 hz - 1 phase		208/230V	208/230V	208/230V	208/230V	
Rated load amps		0.9	1.0	1.5	1.5	
Output (W)		46	46	46	42	
Room Temperature Range (°F)	Cooling	62 - 90	62 - 90	62 - 90	62 - 90	
	Heating	32 - 86	32 - 86	32 - 86	32 - 86	
Air Volume - cfm (High/Medium/Low)		375/300/255	380/310/260	560/485/415	700/635/575	
Sound Data (dBA) - Low/Medium/High		33/37/41	36/39/43	36/39/44	43/47/51	
Piping Connections - Liquid/Gas - o.d. - flare - in.		1/4 / 3/8	1/4 / 1/2	1/4 / 1/2	3/8 / 5/8	
Drain connection o.d. - in.		1	1	1	1-1/4	
Net/Shipping weights - lbs.	Body	32 / 38	36 / 41	36 / 42	47 / 55	
REQUIRED COMPONENTS - ORDERED SEPARATELY						
Cassette Panel		13X04 (M0STAT62Q-1)	13X04 (M0STAT62Q-1)	13X04 (M0STAT62Q-1)	13X05 (M0STAT63Q-1)	
Net/Shipping weights - lbs.		6 / 10	6 / 10	6 / 10	12 / 18	

SPECIFICATIONS
CEILING/FLOOR MOUNT INDOOR UNITS

Model No.		MCFB018S4	MCFA024S4
Nominal Tons		1.5	2
Power Supply - 60 hz - 1 phase		208/230V	208/230V
Rated load amps		1.5	1.5
Output (W)		55	55
Room Temperature Range (°F)	Cooling	62 - 90	62 - 90
	Heating	32 - 86	32 - 86
Air Volume - cfm (High/Medium/Low)		580/520/465	760/710/600
Sound Data (dBA) - Low/Medium/High		39/44/47	42/48/53
Piping Connections - Liquid/Gas - o.d. - flare - in.		1/4 / 1/2	3/8 / 5/8
Drain connection o.d. - in.		1	1
Net/Shipping weights - lbs.		55 / 66	59 / 70

SPECIFICATIONS
FLOOR MOUNT CONSOLE INDOOR UNITS

Model No.		MFMA012S4
Nominal Tons		1
Power Supply - 60 hz - 1 phase		208/230V
Rated load amps		1
Output (W)		20
Room Temperature Range (°F)	Cooling	62 - 90
	Heating	32 - 86
Air Volume - cfm (High/Medium/Low)		365/318/248
Sound Data (dBA) - Low/Medium/High		35/40/45
Piping Connections - Liquid/Gas - o.d. - flare - in.		1/4 / 1/2
Drain connection o.d. - in.		5/8
Net/Shipping weights - lbs.		33 / 43

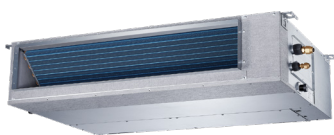
SPECIFICATIONS
MEDIUM STATIC DUCTED INDOOR UNITS

Model No.		MMDB009S4	MMDB012S4	MMDB018S4	MMDB024S4
Nominal Tons		0.75	1	1.5	2
Power Supply - 60 hz - 1 phase		208/230V	208/230V	208/230V	208/230V
Rated load amps		0.9	1.0	1.2	1.5
Output (W)		55	55	160	160
Room Temperature Range (°F)	Cooling	62 - 90	62 - 90	62 - 90	62 - 90
	Heating	32 - 86	32 - 86	32 - 86	32 - 86
Air Volume - cfm (High/Medium/Low)		340/270/165	340/270/165	505/430/350	735/660/415
External Static Pressure (in. w.g)		0 - 0.16	0 - 0.16	0 - 0.40	0 - 0.64
Sound Data (dBA) - Low/Medium/High		25/32/38	26/33.5/38	35/37/39	36/41/44
Piping Connections - Liquid/Gas - o.d. - flare - in.		1/4 / 3/8	1/4 / 1/2	1/4 / 1/2	3/8 / 5/8
Drain connection o.d. - in.		1	1	1	1
Net/Shipping weights - lbs.		38 / 49	38 / 49	54 / 66	87 / 103

AHRI RATINGS

Outdoor Unit Model No.	Number of Zones	System Type	Cooling Btuh	High Temperature Heating Btuh	Low Temperature Heating Btuh	SEER	EER	HSPF (Region IV)	AHRI Reference Number	Energy Star
MPB018S4M	2	Ducted	18,000	18,500	11,500	18.5	11.8	10	203343590	No
		Non-Ducted	18,000	19,000	12,000	22.5	12.5	10.3	203343586	Yes
		Mixed Ducted and Non-Ducted	17,500	18,200	11,550	19.8	12.15	9.85	203343591	Yes
MPB030S4M	Up to 3	Ducted	28,000	28,000	16,200	21	11	10	203343592	No
		Non-Ducted	28,000	28,000	17,600	23	12.5	10.3	203343587	Yes
		Mixed Ducted and Non-Ducted	27,400	27,400	17,700	20.7	11.25	10.4	203343593	Yes
MPB036S4M	Up to 4	Ducted	36,000	37,000	23,000	21	10	10	204330672	No
		Non-Ducted	36,000	36,000	24,600	22.5	11.5	10.2	10062014	No
		Mixed Ducted and Non-Ducted	36,000	36,200	24,600	20.47	10.5	9.97	202119244	Yes
MPB048S4M	Up to 5	Ducted	49,000	50,000	34,000	20.5	10.1	11.5	204330669	No
		Non-Ducted	48,000	48,000	29,600	22.4	12.5	10.2	201771986	Yes
		Mixed Ducted and Non-Ducted	48,000	49,000	32,200	20.17	10.9	10.6	202119245	Yes

NOTE - Per AHRI, the certified ratings for systems are valid for all combinations of indoor units with the specific outdoor units listed above and in the AHRI Directory of Certified Equipment. Please visit <http://www.ahridirectory.org> for further details and latest updates.

¹ Ratings are AHRI certified to AHRI Standard 210/240 with Addenda 1 and 2;

- Cooling Ratings - 80°F dry bulb/67°F wet bulb entering indoor coil air and 95°F dry bulb/75°F wet bulb outdoor air temperature.
- High Temperature Heating Ratings - 70°F dry bulb/60°F wet bulb entering indoor coil air and 47°F dry bulb/43°F wet bulb outdoor air temperature.
- Low Temperature Heating Ratings - 70°F dry bulb/60°F wet bulb entering indoor coil air and 17°F dry bulb/15°F wet bulb outdoor air temperature.

OPTIONAL ACCESSORIES - ORDER SEPARATELY

Description	Catalog No.	Size						
		009	012	018	024	030	036	048
OUTDOOR UNIT								
Condenser Pad (18 x 38 x 3)	Y5014			•		•	•	•
Disconnects	30 amp, fused, 1 ph	27P37		•		•	•	•
	60 amp, non-fused, 1 ph	27P39		•		•	•	•
Fuses	30A	83P75		•		•	•	•
	60A	83P77		•		•	•	•
Hail Guards	M9GARD15Q-1	15D26		•		N/A		
	M9GARD17Q-1	15D28		N/A		•	•	N/A
	M9GARD18Q-1	15D29		N/A		N/A		•
¹ Line Sets	1/4 in. x 3/8 in. x 25 ft.	90X53	N/A	N/A	•	•	•	•
	1/4 in. x 3/8 in. x 50 ft.	X0258			•	•	•	•
	1/4 in. x 1/2 in. x 25 ft.	90X52			•	•	•	•
	1/4 in. x 1/2 in. x 50 ft.	X0259			•	•	•	•
	3/8 in. x 5/8 in. x 25 ft.	X8406			N/A	N/A		•
	3/8 in. x 5/8 in. x 50 ft.	X8407			N/A	N/A		•
	Wall Brackets	30 inch			X1727	•	N/A	
	36 inch	X1728	N/A	•	•	•		
Whips	10 Gauge - 1/2 in. x 6 ft.	29P54	•	•	•	•	•	
	8 Gauge - 3/4 in. x 6 ft.	27P44	•	•	•	•	•	
INDOOR UNIT								
² Diversitech Condensate Pumps with Reservoir	ClearVue Mini™ - 7.9 US gallons per hour, 35 ft. lift - 120-240V	Y5170	•	•	•	•	N/A	
	Mini-Split Pump - 4 US gallons per hour, 20 ft. lift - 115V	Y7946	•	•	N/A			
	Mini-Split Pump - 4 US gallons per hour, 20 ft. lift - 230V	Y7949	•	•	•	•	N/A	
² Blue Diamond® Condensate Pumps with Reservoir	MicroBlue® - 1.3 US gallons per hour, 6 ft. lift - 110-230V	14T74	•	•	•	N/A		
	MaxiBlue® - 3.7 US gallons per hour, 16.5 ft. lift - 208/230V	14T69	N/A		•	•	•	N/A
	MegaBlue® - 13.2 US gallons per hour, 23 ft. lift - 208/230V	14T71	N/A					•
	MultiTank Kit	14T75	N/A		•	•	•	•
	Sensor Cable Extension - 16 ft.	14T76	•	•	•	•	•	•
A/C Easy Tee® Condensate Cleanout	Y7947	•	•	•	•	•	•	
CONTROLS								
Wired Remote Controller (Furnished With All Ducted Models)	M0STAT61Q-1	14A66	•	•	•	•	•	•
Extension Cable for Wired Remote Controller - 20 ft.		Y8008	•	•	•	•	•	•
NOTE - The Wired Remote Controller above is furnished as standard with the indoor ducted models. As an option, the Wired Remote Controller can be ordered for a wall-mount, cassette, floor console or ceiling/floor mount unit if desired.								
Wired Programmable Controller	M0STAT64Q-1	15D30	•	•	•	•	•	•
Extension Cable for Wired Programmable Controller - 20 ft.	M0CTRL64Q-1	Y8738	•	•	•	•	•	•
Indoor/Outdoor Wiring Cable - 14 Gauge, 4 conductor wire, THHN, 250 ft.		Y2067	•	•	•	•	•	•
SPEEDICHANNEL™ SYSTEM								
SpeediChannel™ Starter Kit - 4 in.		Y3387	•	•	•	•	•	•
SpeediChannel - 4 in. x 6-1/2 ft. (qty. 6)		Y3388	•	•	•	•	•	•
Union Coupling - 4 in.		Y3389	•	•	•	•	•	•
90° Flat Bend Elbow - 4 in.		Y3390	•	•	•	•	•	•
90° Inside Elbow - 4 in.		Y3391	•	•	•	•	•	•
45° Flat Bend Elbow - 4 in.		Y3392	•	•	•	•	•	•
Flex Joint - 4 in.		Y3393	•	•	•	•	•	•
T-Joint - 4 in.		Y3394	•	•	•	•	•	•
Duct End - 4 in.		Y3395	•	•	•	•	•	•
Flat Wall Escutcheon - 4 in.		Y3396	•	•	•	•	•	•
Wall Penetration Cover - 4 in.		Y3399	•	•	•	•	•	•
Mount Block (White) Qty, 2 - 14 in.		Y3397	•	•	•	•	•	•
Mount Block (White) Qty, 2 - 36 in.		Y3398	•	•	•	•	•	•

¹ See Connections and Line Set Usage tables on page 26.

² Y7946, Y7949 and 14T74 condensate pumps can be installed inside the indoor units. All other pumps must be installed external to the indoor unit.

SOUND LEVELS - TEST CONDITIONS

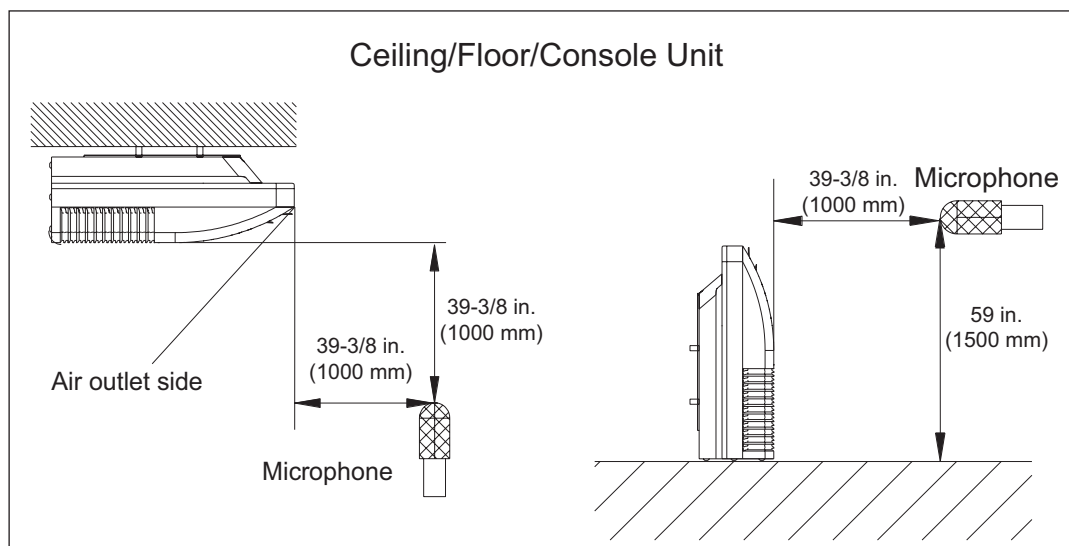
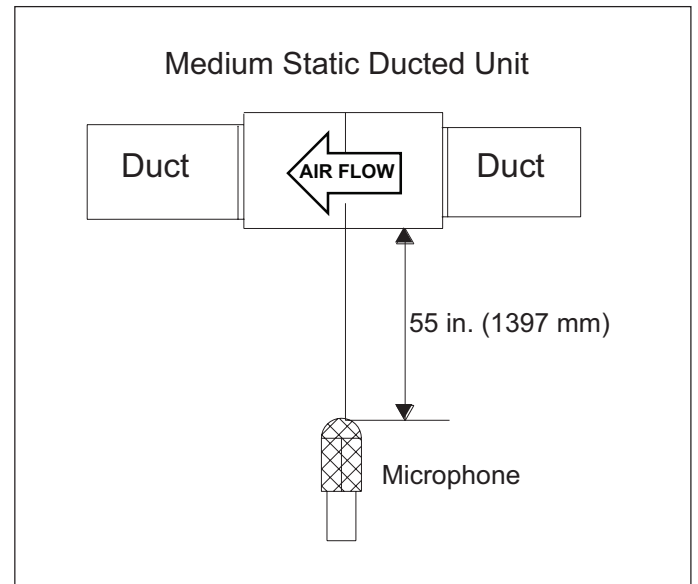
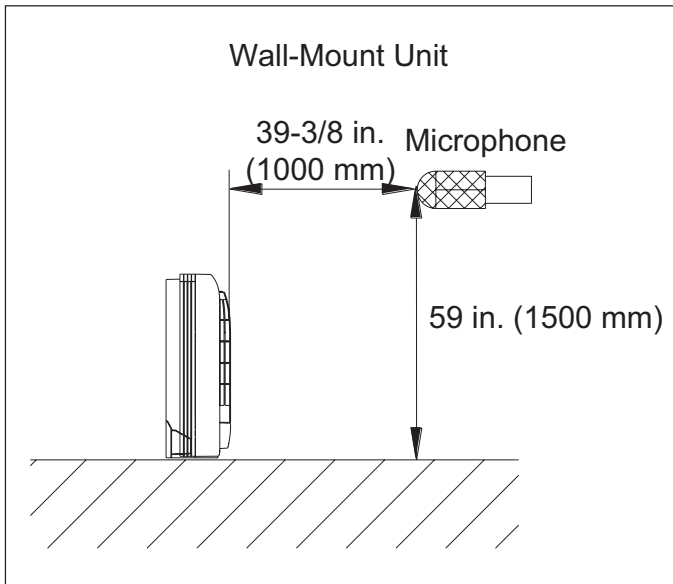
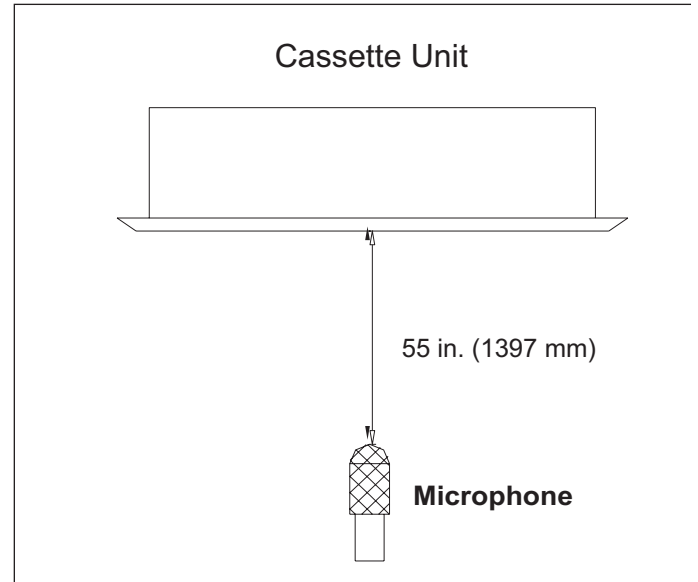
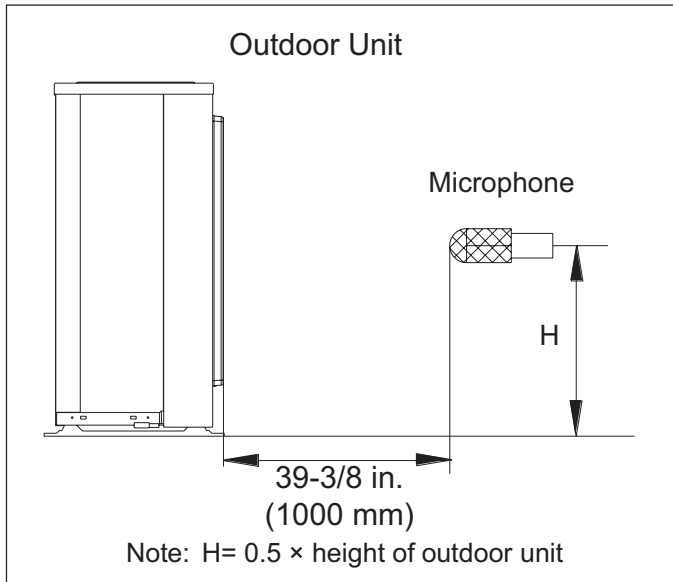

MULTI-ZONE SYSTEM COMBINATIONS

NOTE - For multi-zone systems, the total capacity of all indoor units must be 66% to 133% of the outdoor unit capacity.

Outdoor Unit Model No.	Number of Zones	Indoor Unit Capacity					Nominal Cooling Capacity at Rated System Capacity (Btuh)					Nominal Heating Capacity at Rated System Capacity (Btuh)					
		#1	#2	#3	#4	#5	#1	#2	#3	#4	#5	#1	#2	#3	#4	#5	
MPB018S4M	1	012	---	---	---	---	9,000	---	---	---	---	9,500	---	---	---	---	
	2	009	009	---	---	---	9,000	9,000	---	---	---	9,500	9,500	---	---	---	
		009	012	---	---	---	8,500	10,500	---	---	---	9,000	11,000	---	---	---	
		012	012	---	---	---	9,500	9,500	---	---	---	10,000	10,000	---	---	---	
MPB030S4M	1	018	---	---	---	---	16,600	---	---	---	---	18,000	---	---	---	---	
	2	009	009	---	---	---	9,500	9,500	---	---	---	10,000	10,000	---	---	---	
		009	012	---	---	---	9,500	12,000	---	---	---	10,000	13,000	---	---	---	
		009	018	---	---	---	8,400	16,600	---	---	---	9,000	18,000	---	---	---	
		012	012	---	---	---	12,000	12,000	---	---	---	13,000	13,000	---	---	---	
		012	018	---	---	---	10,000	15,000	---	---	---	11,200	16,800	---	---	---	
		018	018	---	---	---	14,000	14,000	---	---	---	15,000	15,000	---	---	---	
	3	009	009	009	---	---	9,000	9,000	9,000	---	---	9,500	9,500	9,500	---	---	
		009	009	012	---	---	8,667	8,667	11,667	---	---	9,500	9,500	12,000	---	---	
		009	012	012	---	---	8,500	10,500	10,500	---	---	8,500	11,000	11,000	---	---	
		009	009	018	---	---	8,300	8,300	13,500	---	---	8,500	8,500	14,500	---	---	
		012	012	012	---	---	10,000	10,000	10,000	---	---	10,667	10,667	10,667	---	---	
	MPB036S4M	2	009	009	---	---	---	10,000	10,000	---	---	---	10,500	10,500	---	---	---
			009	012	---	---	---	9,500	12,000	---	---	---	10,000	13,000	---	---	---
009			018	---	---	---	9,500	17,500	---	---	---	10,000	18,000	---	---	---	
009			024	---	---	---	9,000	24,000	---	---	---	10,000	25,000	---	---	---	
012			012	---	---	---	12,000	12,000	---	---	---	13,000	13,000	---	---	---	
012			018	---	---	---	12,000	18,000	---	---	---	13,000	18,000	---	---	---	
012			024	---	---	---	11,000	23,000	---	---	---	12,000	24,000	---	---	---	
018			018	---	---	---	16,500	16,500	---	---	---	17,000	17,000	---	---	---	
3		009	009	009	---	---	9,333	9,333	9,333	---	---	9,667	9,667	9,667	---	---	
		009	009	012	---	---	9,000	9,000	12,000	---	---	9,500	9,500	12,500	---	---	
		009	009	018	---	---	8,000	8,000	16,000	---	---	8,500	8,500	17,000	---	---	
		009	012	012	---	---	8,500	11,500	11,500	---	---	9,000	12,000	12,000	---	---	
		009	012	018	---	---	8,000	11,000	15,000	---	---	8,500	11,500	16,000	---	---	
		009	018	018	---	---	8,000	14,000	14,000	---	---	8,500	14,500	14,500	---	---	
		012	012	012	---	---	11,333	11,333	11,333	---	---	12,000	12,000	12,000	---	---	
		012	012	018	---	---	11,000	11,000	14,000	---	---	12,000	12,000	15,000	---	---	
4		012	018	018	---	---	9,333	13,333	13,333	---	---	10,000	14,500	14,500	---	---	
		012	012	024	---	---	8,000	8,000	20,000	---	---	9,000	9,000	21,000	---	---	
		009	009	009	009	---	9,000	9,000	9,000	9,000	---	9,500	9,500	9,500	9,500	---	
		009	009	009	012	---	8,500	8,500	8,500	11,500	---	9,000	9,000	9,000	12,000	---	
	009	009	009	018	---	8,000	8,000	8,000	14,000	---	8,500	8,500	8,500	14,000	---		
	009	009	012	012	---	8,000	8,000	10,500	10,500	---	8,500	8,500	11,000	11,000	---		
	009	009	012	018	---	7,500	7,500	9,000	14,000	---	8,000	8,000	9,500	14,500	---		
	009	012	012	012	---	7,000	10,000	10,000	10,000	---	8,000	10,500	10,500	10,500	---		
012	012	012	012	---	9,500	9,500	9,500	9,500	---	10,000	10,000	10,000	10,000	---			

¹ One outdoor unit may be matched with one indoor unit for single zone applications. A second indoor unit can be added at a later date for multi-zone applications.

MULTI-ZONE SYSTEM COMBINATIONS

NOTE - For multi-zone systems, the total capacity of all indoor units must be 66% to 133% of the outdoor unit capacity.

Outdoor Unit Model No.	Number of Zones	Indoor Unit Capacity					Nominal Cooling Capacity at Rated System Capacity (Btuh)					Nominal Heating Capacity at Rated System Capacity (Btuh)				
		#1	#2	#3	#4	#5	#1	#2	#3	#4	#5	#1	#2	#3	#4	#5
MPB048S4M	2	009	018	---	---	---	9,500	18,000	---	---	---	10,000	18,000	---	---	---
		009	024	---	---	---	9,500	24,000	---	---	---	10,000	25,000	---	---	---
		012	012	---	---	---	12,500	12,500	---	---	---	13,000	13,000	---	---	---
		012	018	---	---	---	12,000	18,000	---	---	---	13,000	19,000	---	---	---
		012	024	---	---	---	12,000	24,000	---	---	---	10,000	25,000	---	---	---
		018	018	---	---	---	18,500	18,500	---	---	---	19,000	19,000	---	---	---
		018	024	---	---	---	17,500	22,500	---	---	---	18,000	23,000	---	---	---
		024	024	---	---	---	21,000	21,000	---	---	---	22,000	22,000	---	---	---
	3	009	009	009	---	---	9,500	9,500	9,500	---	---	11,000	11,000	11,000	---	---
		009	009	012	---	---	9,500	9,500	12,000	---	---	10,000	10,000	13,000	---	---
		009	009	018	---	---	9,500	9,500	18,000	---	---	10,000	10,000	19,000	---	---
		009	009	024	---	---	9,000	9,000	22,500	---	---	9,500	9,500	23,500	---	---
		009	012	012	---	---	9,500	12,500	12,500	---	---	10,000	10,000	13,000	---	---
		009	012	018	---	---	9,000	12,000	18,000	---	---	9,500	9,500	19,000	---	---
		009	012	024	---	---	9,000	12,000	21,500	---	---	9,500	12,500	22,000	---	---
		009	018	018	---	---	9,000	18,000	18,000	---	---	9,500	18,500	18,500	---	---
		009	018	024	---	---	8,500	15,500	21,000	---	---	9,000	16,000	21,500	---	---
		009	024	024	---	---	8,000	20,000	20,000	---	---	8,500	21,000	21,000	---	---
		012	012	012	---	---	12,000	12,000	12,000	---	---	13,000	13,000	13,000	---	---
		012	012	018	---	---	12,000	12,000	17,000	---	---	12,500	12,500	18,000	---	---
		012	018	018	---	---	11,000	16,500	16,500	---	---	11,500	17,000	17,000	---	---
		012	012	024	---	---	11,000	11,000	22,000	---	---	11,500	11,500	23,000	---	---
		012	018	024	---	---	10,500	15,500	21,500	---	---	11,000	16,000	22,000	---	---
		012	024	024	---	---	10,000	20,000	20,000	---	---	11,000	20,500	20,500	---	---
		018	018	018	---	---	16,000	16,000	16,000	---	---	16,500	16,500	16,500	---	---
		018	018	024	---	---	15,000	15,000	20,000	---	---	15,500	15,500	21,000	---	---

¹ One outdoor unit may be matched with one indoor unit for single zone applications. A second indoor unit can be added at a later date for multi-zone applications.

MULTI-ZONE SYSTEM COMBINATIONS

NOTE - For multi-zone systems, the total capacity of all indoor units must be 66% to 133% of the outdoor unit capacity.

Outdoor Unit Model No.	Number of Zones	Indoor Unit Capacity					Nominal Cooling Capacity at Rated System Capacity (Btuh)					Nominal Heating Capacity at Rated System Capacity (Btuh)				
		#1	#2	#3	#4	#5	#1	#2	#3	#4	#5	#1	#2	#3	#4	#5
MPB048S4M	4	009	009	009	009	---	9,250	9,250	9,250	9,250	---	9,500	9,500	9,500	9,500	---
		009	009	009	012	---	9,000	9,000	9,000	12,000	---	9,500	9,500	9,500	12,500	---
		009	009	009	018	---	9,000	9,000	9,000	17,000	---	9,500	9,500	9,500	17,500	---
		009	009	009	024	---	8,500	8,500	8,500	20,500	---	9,000	9,000	9,000	21,000	---
		009	009	012	012	---	9,000	9,000	12,000	12,000	---	9,500	9,500	13,000	13,000	---
		009	009	012	018	---	9,000	9,000	11,000	17,000	---	9,500	9,500	11,500	17,500	---
		009	009	012	024	---	8,500	8,500	10,500	20,500	---	9,000	9,000	11,100	21,000	---
		009	009	018	018	---	8,500	8,500	15,500	15,500	---	9,000	9,000	16,000	16,000	---
		009	009	018	024	---	8,000	8,000	14,500	20,000	---	8,500	8,500	15,000	20,000	---
		009	012	012	012	---	9,000	12,000	12,000	12,000	---	9,500	12,500	12,500	12,500	---
		009	012	012	018	---	9,000	11,000	11,000	16,000	---	9,500	11,500	11,500	16,500	---
		009	012	012	024	---	8,500	10,000	10,000	20,000	---	9,000	10,500	10,500	20,500	---
		009	012	018	018	---	8,500	10,000	15,000	15,000	---	9,000	10,500	15,500	15,500	---
		009	018	018	018	---	8,000	14,000	14,000	14,000	---	8,500	14,500	14,500	14,500	---
		012	012	012	012	---	12,000	12,000	12,000	12,000	---	12,500	12,500	12,500	12,500	---
		012	012	012	018	---	11,000	11,000	11,000	16,000	---	11,500	11,500	11,500	16,500	---
	012	012	012	024	---	10,000	10,000	10,000	20,000	---	10,500	10,500	10,500	20,500	---	
	012	012	018	018	---	10,000	10,000	15,000	15,000	---	10,500	10,500	15,500	15,500	---	
	5	009	009	009	009	009	9,000	9,000	9,000	9,000	9,000	9,500	9,500	9,500	9,500	9,500
		009	009	009	009	012	9,000	9,000	9,000	9,000	12,000	9,500	9,500	9,500	9,500	13,000
009		009	009	009	018	8,500	8,500	8,500	8,500	16,000	9,000	9,000	9,000	9,000	16,500	
009		009	009	009	024	7,750	7,750	7,750	7,750	19,500	8,000	8,000	8,000	8,000	20,000	
009		009	009	012	012	9,000	9,000	9,000	11,500	11,500	9,500	9,500	9,500	12,000	12,000	
009		009	009	012	018	8,000	8,000	8,000	11,000	16,000	8,500	8,500	8,500	11,500	16,500	
009		009	009	018	018	8,000	8,000	8,000	11,000	16,000	8,500	8,500	8,500	16,500	16,500	
009		009	012	012	012	8,500	8,500	11,000	11,000	11,000	9,000	9,000	12,000	12,000	12,000	
009		009	012	012	018	8,500	8,500	10,000	10,000	15,000	8,500	8,500	10,500	10,500	15,500	
009		012	012	012	012	8,000	11,000	11,000	11,000	11,000	8,500	11,500	11,500	11,500	11,500	
009		012	012	012	018	7,500	10,000	10,000	10,000	14,500	8,000	10,500	10,500	10,500	15,000	
012		012	012	012	012	10,500	10,500	10,500	10,500	10,500	11,000	11,000	11,000	11,000	11,000	

¹ One outdoor unit may be matched with one indoor unit for single zone applications. A second indoor unit can be added at a later date for multi-zone applications.

CONNECTIONS AND LINE SET USAGE

Outdoor Model	No. of Zones	Indoor Unit Capacity (Unit No.)	Line Set Required (Liquid x Gas)	
MPB018S4M Indoor Unit A 1/4" liq + 3/8" gas Indoor Unit B 1/4" liq + 3/8" gas	1	012 (A)	¹ 1/4 in. x 1/2 in.	
	2	009 (A) 009 (B)	1/4 in. x 3/8 in. 1/4 in. x 3/8 in.	
	2	009 (B) 012 (A)	1/4 in. x 3/8 in. ¹ 1/4 in. x 1/2 in.	
	2	012 (A) 012 (B)	¹ 1/4 in. x 1/2 in. ¹ 1/4 in. x 1/2 in.	
MPB030S4M Indoor Unit A 1/4" liq + 3/8" gas Indoor Unit B 1/4" liq + 3/8" gas Indoor Unit C 1/4" liq + 3/8" gas	1	018 (A)	¹ 1/4 in. x 1/2 in.	
	2	009 (A) 009 (B)	1/4 in. x 3/8 in. 1/4 in. x 3/8 in.	
	2	009 (B) 012 (A)	1/4 in. x 3/8 in. ¹ 1/4 in. x 1/2 in.	
	2	009 (B) 018 (A)	1/4 in. x 3/8 in. ¹ 1/4 in. x 1/2 in.	
	2	012 (A) 012 (B)	¹ 1/4 in. x 1/2 in. ¹ 1/4 in. x 1/2 in.	
	2	012 (B) 018 (A)	¹ 1/4 in. x 1/2 in. ¹ 1/4 in. x 1/2 in.	
	2	018 (A) 018 (B)	¹ 1/4 in. x 1/2 in. ¹ 1/4 in. x 1/2 in.	
	3	009 (A) 009 (B) 009 (C)	1/4 in. x 3/8 in. 1/4 in. x 3/8 in. 1/4 in. x 3/8 in.	
	3	009 (B) 009 (C) 012 (A)	1/4 in. x 3/8 in. 1/4 in. x 3/8 in. ¹ 1/4 in. x 1/2 in.	
	3	009 (C) 012 (A) 012 (B)	1/4 in. x 3/8 in. ¹ 1/4 in. x 1/2 in. ¹ 1/4 in. x 1/2 in.	
	3	009 (B) 009 (C) 018 (A)	1/4 in. x 3/8 in. 1/4 in. x 3/8 in. ¹ 1/4 in. x 1/2 in.	
	3	012 (A) 012 (B) 012 (C)	¹ 1/4 in. x 1/2 in. ¹ 1/4 in. x 1/2 in. ¹ 1/4 in. x 1/2 in.	
	MPB036S4M Indoor Unit A 1/4" liq + 1/2" gas Indoor Unit B 1/4" liq + 3/8" gas Indoor Unit C 1/4" liq + 3/8" gas Indoor Unit D 1/4" liq + 3/8" gas	2	009 (B) 018 (A)	1/4 in. x 3/8 in. 1/4 in. x 1/2 in.
		2	009 (B) 024 (A)	1/4 in. x 3/8 in. ^{2,3} 3/8 in. x 5/8 in.
2		012 (A) 012 (B)	1/4 in. x 1/2 in. ¹ 1/4 in. x 1/2 in.	
2		012 (B) 018 (A)	¹ 1/4 in. x 1/2 in. 1/4 in. x 1/2 in.	
2		012 (B) 024 (A)	¹ 1/4 in. x 1/2 in. ^{2,3} 3/8 in. x 5/8 in.	
2		018 (A) 018 (B)	1/4 in. x 1/2 in. ¹ 1/4 in. x 1/2 in.	
3		009 (B) 009 (C) 009 (D)	1/4 in. x 3/8 in. 1/4 in. x 3/8 in. 1/4 in. x 3/8 in.	

¹ 3/8 x 1/2 in. gas pipe adaptor is required for line set connection to outdoor unit (furnished with outdoor unit).

² 1/4 x 3/8 in. liquid pipe adaptor is required for line set connection to the 048 outdoor unit (furnished with outdoor unit).

³ 1/2 x 5/8 in. gas pipe adaptor is required for line set connection to the 048 outdoor unit (furnished with outdoor unit).

CONNECTIONS AND LINE SET USAGE

Outdoor Model	No. of Zones	Indoor Unit Capacity (Unit No.)	Line Set Required (Liquid x Gas)
MPB036S4M Indoor Unit A 1/4" liq + 1/2" gas Indoor Unit B 1/4" liq + 3/8" gas Indoor Unit C 1/4" liq + 3/8" gas Indoor Unit D 1/4" liq + 3/8" gas	3	009 (B) 009 (C) 012 (A)	1/4 in. x 3/8 in. 1/4 in. x 3/8 in. 1/4 in. x 1/2 in.
	3	009 (B) 009 (C) 018 (A)	1/4 in. x 3/8 in. 1/4 in. x 3/8 in. 1/4 in. x 1/2 in.
	3	009 (C) 012 (A) 012 (B)	1/4 in. x 3/8 in. 1/4 in. x 1/2 in. ¹ 1/4 in. x 1/2 in.
	3	009 (C) 012 (B) 018 (A)	1/4 in. x 3/8 in. ¹ 1/4 in. x 1/2 in. 1/4 in. x 1/2 in.
	3	009 (C) 018 (A) 018 (B)	1/4 in. x 3/8 in. 1/4 in. x 1/2 in. ¹ 1/4 in. x 1/2 in.
	3	012 (A) 012 (B) 012 (C)	1/4 in. x 1/2 in. ¹ 1/4 in. x 1/2 in. ¹ 1/4 in. x 1/2 in.
	3	012 (C) 012 (B) 018 (A)	¹ 1/4 in. x 1/2 in. ¹ 1/4 in. x 1/2 in. 1/4 in. x 1/2 in.
	3	012 (C) 018 (A) 018 (B)	¹ 1/4 in. x 1/2 in. 1/4 in. x 1/2 in. ¹ 1/4 in. x 1/2 in.
	3	012 (B) 012 (C) 024 (A)	¹ 1/4 in. x 1/2 in. ¹ 1/4 in. x 1/2 in. ^{2,3} 3/8 in. x 5/8 in.
	4	009 (B) 009 (C) 009 (D) 009 (A)	1/4 in. x 3/8 in. 1/4 in. x 3/8 in. 1/4 in. x 3/8 in. ¹ 1/4 in. x 3/8 in.
	4	009 (B) 009 (C) 009 (D) 012 (A)	1/4 in. x 3/8 in. 1/4 in. x 3/8 in. 1/4 in. x 3/8 in. 1/4 in. x 1/2 in.
	4	009 (B) 009 (C) 009 (D) 018 (A)	1/4 in. x 3/8 in. 1/4 in. x 3/8 in. 1/4 in. x 3/8 in. 1/4 in. x 1/2 in.
	4	009 (C) 009 (D) 012 (A) 012 (B)	1/4 in. x 3/8 in. 1/4 in. x 3/8 in. 1/4 in. x 1/2 in. ¹ 1/4 in. x 1/2 in.
	4	009 (D) 012 (A) 012 (B) 012 (C)	1/4 in. x 3/8 in. 1/4 in. x 1/2 in. ¹ 1/4 in. x 1/2 in. ¹ 1/4 in. x 1/2 in.
4	012 (A) 012 (B) 012 (C) 012 (D)	1/4 in. x 1/2 in. ¹ 1/4 in. x 1/2 in. ¹ 1/4 in. x 1/2 in. ¹ 1/4 in. x 1/2 in.	

¹ 3/8 x 1/2 in. gas pipe adaptor is required for line set connection to outdoor unit (furnished with outdoor unit).

² 1/4 x 3/8 in. liquid pipe adaptor is required for line set connection to the 048 outdoor unit (furnished with outdoor unit).

³ 1/2 x 5/8 in. gas pipe adaptor is required for line set connection to the 048 outdoor unit (furnished with outdoor unit).

CONNECTIONS AND LINE SET USAGE

Outdoor Model	No. of Zones	Indoor Unit Capacity (Unit No.)	Line Set Required (Liquid x Gas)
MPB048S4M Indoor Unit A 1/4" liq + 1/2" gas Indoor Unit B 1/4" liq + 1/2" gas Indoor Unit C 1/4" liq + 3/8" gas Indoor Unit D 1/4" liq + 3/8" gas Indoor Unit E 1/4" liq + 3/8" gas	2	009 (B) 018 (A)	¹ 1/4 in. x 3/8 in. 1/4 in. x 1/2 in.
	2	009 (B) 024 (A)	¹ 1/4 in. x 3/8 in. ^{2,3} 3/8 in. x 5/8 in.
	2	012 (A) 012 (B)	1/4 in. x 1/2 in. 1/4 in. x 1/2 in.
	2	012 (B) 018 (A)	1/4 in. x 1/2 in. 1/4 in. x 1/2 in.
	2	012 (B) 024 (A)	1/4 in. x 1/2 in. ^{2,3} 3/8 in. x 5/8 in.
	2	018 (A) 018 (B)	1/4 in. x 1/2 in. 1/4 in. x 1/2 in.
	2	018 (B) 024 (A)	1/4 in. x 1/2 in. ^{2,3} 3/8 in. x 5/8 in.
	2	024 (A) 024 (B)	^{2,3} 3/8 in. x 5/8 in. ^{2,3} 3/8 in. x 5/8 in.
	3	009 (A) 009 (B) 009 (C)	¹ 1/4 in. x 3/8 in. ¹ 1/4 in. x 3/8 in. 1/4 in. x 3/8 in.
	3	009 (B) 009 (C) 012 (A)	¹ 1/4 in. x 3/8 in. 1/4 in. x 3/8 in. 1/4 in. x 1/2 in.
	3	009 (B) 009 (C) 018 (A)	¹ 1/4 in. x 3/8 in. 1/4 in. x 3/8 in. 1/4 in. x 1/2 in.
	3	009 (B) 009 (C) 024 (A)	¹ 1/4 in. x 3/8 in. 1/4 in. x 3/8 in. ^{2,3} 3/8 in. x 5/8 in.
	3	009 (C) 012 (A) 012 (B)	1/4 in. x 3/8 in. 1/4 in. x 1/2 in. 1/4 in. x 1/2 in.
	3	009 (C) 012 (B) 018 (A)	1/4 in. x 3/8 in. 1/4 in. x 1/2 in. 1/4 in. x 1/2 in.
	3	009 (C) 012 (B) 024 (A)	1/4 in. x 3/8 in. 1/4 in. x 1/2 in. ^{2,3} 3/8 in. x 5/8 in.
	3	009 (C) 018 (A) 018 (B)	1/4 in. x 3/8 in. 1/4 in. x 1/2 in. 1/4 in. x 1/2 in.
	3	009 (C) 018 (B) 024 (A)	1/4 in. x 3/8 in. 1/4 in. x 1/2 in. ^{2,3} 3/8 in. x 5/8 in.
	3	009 (C) 024 (A) 024 (B)	1/4 in. x 3/8 in. ^{2,3} 3/8 in. x 5/8 in. ^{2,3} 3/8 in. x 5/8 in.
	3	012 (A) 012 (B) 012 (C)	1/4 in. x 1/2 in. 1/4 in. x 1/2 in. ¹ 1/4 in. x 1/2 in.
	3	012 (B) 012 (C) 018 (A)	1/4 in. x 1/2 in. ¹ 1/4 in. x 1/2 in. 1/4 in. x 1/2 in.

¹ 3/8 x 1/2 in. gas pipe adaptor is required for line set connection to outdoor unit (furnished with outdoor unit).

² 1/4 x 3/8 in. liquid pipe adaptor is required for line set connection to the 048 outdoor unit (furnished with outdoor unit).

³ 1/2 x 5/8 in. gas pipe adaptor is required for line set connection to the 048 outdoor unit (furnished with outdoor unit).

CONNECTIONS AND LINE SET USAGE

Outdoor Model	No. of Zones	Indoor Unit Capacity (Unit No.)	Line Set Required (Liquid x Gas)
MPB048S4M Indoor Unit A 1/4" liq + 1/2" gas Indoor Unit B 1/4" liq + 1/2" gas Indoor Unit C 1/4" liq + 3/8" gas Indoor Unit D 1/4" liq + 3/8" gas Indoor Unit E 1/4" liq + 3/8" gas	3	012 (C) 018 (A) 018 (B)	1/4 in. x 1/2 in. 1/4 in. x 1/2 in. ¹ 1/4 in. x 1/2 in.
	3	012 (B) 012 (C) 024 (A)	1/4 in. x 1/2 in. ¹ 1/4 in. x 1/2 in. ^{2,3} 3/8 in. x 5/8 in.
	3	012 (B) 018 (C) 024 (A)	1/4 in. x 1/2 in. ¹ 1/4 in. x 1/2 in. ^{2,3} 3/8 in. x 5/8 in.
	3	012 (C) 024 (A) 024 (B)	¹ 1/4 in. x 1/2 in. ^{2,3} 3/8 in. x 5/8 in. ^{2,3} 3/8 in. x 5/8 in.
	3	018 (A) 018 (B) 018 (C)	1/4 in. x 1/2 in. 1/4 in. x 1/2 in. ¹ 1/4 in. x 1/2 in.
	3	018 (B) 018 (C) 024 (A)	1/4 in. x 1/2 in. ¹ 1/4 in. x 1/2 in. ^{2,3} 3/8 in. x 5/8 in.
	3	009 (A) 009 (B) 009 (C) 009 (D)	¹ 1/4 in. x 3/8 in. ¹ 1/4 in. x 3/8 in. 1/4 in. x 3/8 in. 1/4 in. x 3/8 in.
	4	009 (B) 009 (C) 009 (D)	¹ 1/4 in. x 3/8 in. ¹ 1/4 in. x 3/8 in. 1/4 in. x 3/8 in.
	4	009 (B) 009 (C) 009 (D) 012 (A)	¹ 1/4 in. x 3/8 in. 1/4 in. x 3/8 in. 1/4 in. x 3/8 in. 1/4 in. x 1/2 in.
	4	009 (B) 009 (C) 009 (D) 018 (A)	¹ 1/4 in. x 3/8 in. 1/4 in. x 3/8 in. 1/4 in. x 3/8 in. 1/4 in. x 1/2 in.
	4	009 (B) 009 (C) 009 (D) 024 (A)	¹ 1/4 in. x 3/8 in. 1/4 in. x 3/8 in. 1/4 in. x 3/8 in. ^{2,3} 3/8 in. x 5/8 in.
	4	009 (C) 009 (D) 012 (A) 012 (B)	1/4 in. x 3/8 in. 1/4 in. x 3/8 in. 1/4 in. x 1/2 in. 1/4 in. x 1/2 in.
	4	009 (C) 009 (D) 012 (B) 018 (A)	1/4 in. x 3/8 in. 1/4 in. x 3/8 in. 1/4 in. x 1/2 in. 1/4 in. x 1/2 in.
	4	009 (C) 009 (D) 018 (A) 018 (B)	1/4 in. x 3/8 in. 1/4 in. x 3/8 in. 1/4 in. x 1/2 in. 1/4 in. x 1/2 in.
	4	009 (C) 009 (D) 018 (B) 024 (A)	1/4 in. x 3/8 in. 1/4 in. x 3/8 in. 1/4 in. x 1/2 in. ^{2,3} 3/8 in. x 5/8 in.

¹ 3/8 x 1/2 in. gas pipe adaptor is required for line set connection to outdoor unit (furnished with outdoor unit).

² 1/4 x 3/8 in. liquid pipe adaptor is required for line set connection to the 048 outdoor unit (furnished with outdoor unit).

³ 1/2 x 5/8 in. gas pipe adaptor is required for line set connection to the 048 outdoor unit (furnished with outdoor unit).

CONNECTIONS AND LINE SET USAGE

Outdoor Model	No. of Zones	Indoor Unit Capacity (Unit No.)	Line Set Required (Liquid x Gas)
MPB048S4M Indoor Unit A 1/4" liq + 1/2" gas Indoor Unit B 1/4" liq + 1/2" gas Indoor Unit C 1/4" liq + 3/8" gas Indoor Unit D 1/4" liq + 3/8" gas Indoor Unit E 1/4" liq + 3/8" gas	4	009 (D)	1/4 in. x 3/8 in.
		012 (A)	¹ 1/4 in. x 1/2 in.
		012 (B)	¹ 1/4 in. x 1/2 in.
		012 (C)	1/4 in. x 1/2 in.
	4	009 (D)	1/4 in. x 3/8 in.
		012 (B)	1/4 in. x 1/2 in.
		012 (C)	¹ 1/4 in. x 1/2 in.
		018 (A)	1/4 in. x 1/2 in.
	4	009 (D)	1/4 in. x 3/8 in.
		012 (B)	1/4 in. x 1/2 in.
		012 (C)	¹ 1/4 in. x 1/2 in.
		024 (A)	^{2,3} 3/8 in. x 5/8 in.
	4	009 (D)	1/4 in. x 3/8 in.
		012 (C)	¹ 1/4 in. x 1/2 in.
		018 (A)	1/4 in. x 1/2 in.
		018 (B)	1/4 in. x 1/2 in.
	4	009 (D)	1/4 in. x 3/8 in.
		018 (A)	1/4 in. x 1/2 in.
018 (B)		1/4 in. x 1/2 in.	
018 (C)		¹ 1/4 in. x 1/2 in.	
4	012 (A)	1/4 in. x 1/2 in.	
	012 (B)	1/4 in. x 1/2 in.	
	012 (C)	¹ 1/4 in. x 1/2 in.	
	012 (D)	¹ 1/4 in. x 1/2 in.	
4	012 (B)	1/4 in. x 1/2 in.	
	012 (C)	¹ 1/4 in. x 1/2 in.	
	012 (D)	¹ 1/4 in. x 1/2 in.	
	024 (A)	^{2,3} 3/8 in. x 5/8 in.	
4	012 (B)	1/4 in. x 1/2 in.	
	012 (C)	¹ 1/4 in. x 1/2 in.	
	012 (D)	¹ 1/4 in. x 1/2 in.	
	018 (A)	¹ 1/4 in. x 1/2 in.	
	018 (A)	¹ 1/4 in. x 1/2 in.	
5	009 (A)	¹ 1/4 in. x 3/8 in.	
	009 (B)	¹ 1/4 in. x 3/8 in.	
	009 (C)	1/4 in. x 3/8 in.	
	009 (D)	1/4 in. x 3/8 in.	
	009 (E)	1/4 in. x 3/8 in.	
5	009 (B)	¹ 1/4 in. x 3/8 in.	
	009 (C)	1/4 in. x 3/8 in.	
	009 (D)	1/4 in. x 3/8 in.	
	009 (E)	1/4 in. x 3/8 in.	
	012 (A)	1/4 in. x 1/2 in.	

¹ 3/8 x 1/2 in. gas pipe adaptor is required for line set connection to outdoor unit (furnished with outdoor unit).

² 1/4 x 3/8 in. liquid pipe adaptor is required for line set connection to the 048 outdoor unit (furnished with outdoor unit).

³ 1/2 x 5/8 in. gas pipe adaptor is required for line set connection to the 048 outdoor unit (furnished with outdoor unit).

CONNECTIONS AND LINE SET USAGE

Outdoor Model	No. of Zones	Indoor Unit Capacity (Unit No.)	Line Set Required (Liquid x Gas)
MPB048S4M Indoor Unit A 1/4" liq + 1/2" gas Indoor Unit B 1/4" liq + 1/2" gas Indoor Unit C 1/4" liq + 3/8" gas Indoor Unit D 1/4" liq + 3/8" gas Indoor Unit E 1/4" liq + 3/8" gas	5	009 (B)	¹ 1/4 in. x 3/8 in.
		009 (C)	1/4 in. x 3/8 in.
		009 (D)	1/4 in. x 3/8 in.
		009 (E)	1/4 in. x 3/8 in.
		018 (A)	1/4 in. x 1/2 in.
	5	009 (B)	¹ 1/4 in. x 3/8 in.
		009 (C)	1/4 in. x 3/8 in.
		009 (D)	1/4 in. x 3/8 in.
		009 (E)	1/4 in. x 3/8 in.
		024 (A)	^{2,3} 3/8 in. x 5/8 in.
	5	009 (C)	1/4 in. x 3/8 in.
		009 (D)	1/4 in. x 3/8 in.
		009 (E)	1/4 in. x 3/8 in.
		012 (A)	1/4 in. x 1/2 in.
		012 (B)	1/4 in. x 1/2 in.
	5	009 (C)	1/4 in. x 3/8 in.
		009 (D)	1/4 in. x 3/8 in.
		009 (E)	1/4 in. x 3/8 in.
		012 (B)	1/4 in. x 1/2 in.
		018 (A)	1/4 in. x 1/2 in.
	5	009 (C)	1/4 in. x 3/8 in.
		009 (D)	1/4 in. x 3/8 in.
		009 (E)	1/4 in. x 3/8 in.
		012 (A)	1/4 in. x 1/2 in.
012 (C)		¹ 1/4 in. x 1/2 in.	
5	009 (D)	1/4 in. x 3/8 in.	
	009 (E)	1/4 in. x 3/8 in.	
	012 (B)	1/4 in. x 1/2 in.	
	012 (C)	¹ 1/4 in. x 1/2 in.	
	018 (A)	1/4 in. x 1/2 in.	
5	009 (E)	1/4 in. x 3/8 in.	
	012 (A)	1/4 in. x 1/2 in.	
	012 (B)	1/4 in. x 1/2 in.	
	012 (C)	¹ 1/4 in. x 1/2 in.	
	012 (D)	¹ 1/4 in. x 1/2 in.	
5	009 (D)	1/4 in. x 3/8 in.	
	012 (E)	1/4 in. x 3/8 in.	
	012 (B)	1/4 in. x 1/2 in.	
	012 (C)	¹ 1/4 in. x 1/2 in.	
	018 (A)	1/4 in. x 1/2 in.	
5	012 (A)	1/4 in. x 1/2 in.	
	012 (B)	1/4 in. x 1/2 in.	
	012 (C)	¹ 1/4 in. x 1/2 in.	
	012 (D)	¹ 1/4 in. x 1/2 in.	
	012 (E)	¹ 1/4 in. x 1/2 in.	

¹ 3/8 x 1/2 in. gas pipe adaptor is required for line set connection to outdoor unit (furnished with outdoor unit).

² 1/4 x 3/8 in. liquid pipe adaptor is required for line set connection to the 048 outdoor unit (furnished with outdoor unit).

³ 1/2 x 5/8 in. gas pipe adaptor is required for line set connection to the 048 outdoor unit (furnished with outdoor unit).

COOLING CAPACITY

018

Outdoor Temperature - °F (Dry Bulb)	Indoor Temperature - °F (Dry Bulb / Wet Bulb)							
	65°F / 54°F		70°F / 59°F		75°F / 63°F		80°F / 67°F	
	Total mBtuh	Sensible mBtuh	Total mBtuh	Sensible mBtuh	Total mBtuh	Sensible mBtuh	Total mBtuh	Sensible mBtuh
-13	17.27	13.47	18.77	14.64	20.28	14.19	21.23	15.93
-5	18.18	14.18	19.76	15.41	21.34	14.93	22.35	16.77
-4	18.27	14.25	19.86	15.49	21.45	15.01	22.46	16.85
0	18.09	14.11	19.66	15.34	21.23	15.29	22.18	16.64
5	17.72	13.83	19.26	15.03	20.81	15.40	22.53	18.05
15	17.36	13.54	18.87	14.72	20.38	15.28	22.85	17.14
25	17.92	13.98	19.48	15.19	21.04	15.85	23.28	17.46
35	18.48	14.41	20.08	15.67	21.69	16.41	23.72	17.79
45	19.03	14.85	20.69	16.14	22.35	16.98	24.15	18.11
55	19.37	15.11	21.05	16.43	22.74	17.44	24.47	18.18
65	19.70	15.38	21.42	16.71	23.13	17.89	24.79	18.26
75	20.04	15.64	21.78	17.00	23.52	18.35	25.11	18.33
85	18.34	14.67	19.94	15.95	21.54	17.01	23.85	17.89
95	16.49	14.01	17.92	15.23	19.35	15.87	21.54	16.16
105	11.04	11.04	12.00	12.00	12.96	11.53	14.82	14.52
115	10.65	10.65	11.58	11.58	12.51	11.88	14.22	14.08
122	9.10	9.10	9.89	9.89	10.13	9.93	10.40	10.40

HEATING CAPACITY

018

Outdoor Temperature - °F (Dry Bulb)	Indoor Temperature - °F (Dry Bulb)			
	60°F	65°F	70°F	75°F
	Total mBtuh	Total mBtuh	Total mBtuh	Total mBtuh
-13	9.54	9.40	6.54	6.44
-5	11.60	11.43	7.69	7.57
0	12.54	12.35	8.14	8.02
5	13.98	13.77	9.66	9.52
17	19.21	18.92	13.02	12.79
19.4	19.46	19.17	15.94	15.70
24.8	20.59	20.28	17.13	16.87
32	20.74	20.43	18.93	18.65
35	21.67	21.34	19.66	19.37
39.2	23.23	22.88	21.33	21.01
44.6	24.79	24.41	23.00	22.66
47	25.82	25.43	23.96	23.60
53.6	26.94	26.54	26.27	25.88
57	27.35	26.94	26.67	26.27

COOLING CAPACITY

030

Outdoor Temperature - °F (Dry Bulb)	Indoor Temperature - °F (Dry Bulb / Wet Bulb)							
	65°F / 54°F		70°F / 59°F		75°F / 63°F		80°F / 67°F	
	Total mBtuh	Sensible mBtuh	Total mBtuh	Sensible mBtuh	Total mBtuh	Sensible mBtuh	Total mBtuh	Sensible mBtuh
-13	28.49	19.95	30.97	21.68	33.45	23.41	35.12	24.59
-5	29.99	21.00	32.60	22.83	35.21	24.65	36.96	25.88
-4	30.14	21.10	32.76	22.94	35.39	24.77	37.15	26.01
0	29.97	20.99	32.58	22.81	35.19	24.63	37.24	26.07
5	29.99	20.99	32.60	22.82	35.21	24.65	37.08	25.96
15	29.58	20.71	32.15	22.51	34.72	24.31	37.51	26.26
25	29.76	20.84	32.35	22.65	34.94	24.46	37.57	26.30
35	29.95	20.97	32.55	22.79	35.15	24.61	37.62	26.34
45	30.13	21.10	32.75	22.93	35.37	24.76	37.68	26.38
55	30.03	21.87	32.65	23.78	35.26	25.27	37.63	26.57
65	29.94	22.65	32.54	24.62	35.15	25.77	37.58	26.76
75	29.84	23.43	32.44	25.47	35.04	26.28	37.53	26.95
85	24.78	20.99	26.94	22.82	29.10	23.86	35.39	26.08
95	22.50	19.96	24.46	21.70	26.42	22.72	32.75	25.06
105	18.38	17.87	19.98	19.42	21.58	19.42	24.71	22.09
115	16.16	15.83	17.56	17.21	18.96	18.02	23.96	23.84
122	14.21	14.21	15.45	15.45	16.69	16.52	20.15	20.05

HEATING CAPACITY

030

Outdoor Temperature - °F (Dry Bulb)	Indoor Temperature - °F (Dry Bulb)			
	60°F	65°F	70°F	75°F
	Total mBtuh	Total mBtuh	Total mBtuh	Total mBtuh
-13	14.95	14.73	10.94	10.78
-5	17.25	16.99	12.26	12.08
0	18.73	18.45	14.52	14.30
5	20.15	19.85	16.82	16.57
17	20.66	20.35	20.94	20.63
19.4	21.04	20.72	21.08	20.76
24.8	22.31	21.98	21.09	20.77
32	20.43	20.12	20.13	19.83
35	22.22	21.89	22.11	21.78
39.2	29.57	29.13	29.17	28.73
44.6	36.92	36.37	36.22	35.68
47	38.03	37.46	37.23	36.75
53.6	40.27	39.67	40.10	39.50
57	40.88	40.27	40.71	40.10

COOLING CAPACITY

036

Outdoor Temperature - °F (Dry Bulb)	Indoor Temperature - °F (Dry Bulb / Wet Bulb)							
	65°F / 54°F		70°F / 59°F		75°F / 63°F		80°F / 67°F	
	Total mBtuh	Sensible mBtuh	Total mBtuh	Sensible mBtuh	Total mBtuh	Sensible mBtuh	Total mBtuh	Sensible mBtuh
-13	33.15	24.42	36.03	26.54	37.17	27.35	37.95	27.89
-5	34.90	25.70	37.93	27.94	39.12	28.79	39.95	29.36
-4	35.07	25.83	38.12	28.08	39.32	28.93	40.15	29.51
0	35.22	25.94	38.28	28.20	39.49	29.04	40.51	29.76
5	35.46	25.47	38.54	27.68	39.73	28.51	40.98	29.83
15	35.13	25.24	38.18	27.43	40.36	28.25	41.10	29.47
25	35.93	26.21	39.06	28.49	40.92	29.34	41.60	30.30
35	36.74	27.19	39.93	29.55	41.47	30.44	42.11	31.13
45	37.55	28.16	40.81	30.61	42.03	31.53	42.61	31.96
55	37.23	28.46	40.47	30.93	41.81	32.33	42.54	32.07
65	36.92	28.75	40.13	31.25	41.60	33.13	42.48	32.19
75	36.61	29.04	39.79	31.57	41.38	33.93	42.41	32.30
85	34.94	28.27	37.98	30.73	41.02	36.10	40.63	31.45
95	33.27	27.47	36.16	29.86	39.05	35.15	38.82	30.57
105	25.95	24.29	28.21	26.40	30.47	28.03	32.17	28.30
115	24.44	24.09	26.56	26.18	28.68	27.25	30.47	30.18
122	21.58	21.27	23.46	23.12	25.34	24.83	27.53	27.25

HEATING CAPACITY

036

Outdoor Temperature - °F (Dry Bulb)	Indoor Temperature - °F (Dry Bulb)			
	60°F	65°F	70°F	75°F
	Total mBtuh	Total mBtuh	Total mBtuh	Total mBtuh
-13	20.54	20.23	15.65	15.42
-5	22.52	22.18	17.05	16.79
0	24.84	24.47	19.02	18.73
5	26.33	25.94	21.31	20.99
17	30.77	30.31	26.67	26.27
19.4	31.06	30.59	27.13	26.72
24.8	32.46	31.97	31.86	31.38
32	34.15	33.64	33.96	33.45
35	36.09	35.55	36.08	35.54
39.2	37.28	36.72	36.65	36.10
44.6	38.47	37.89	37.21	36.65
47	39.24	38.65	37.95	37.38
53.6	41.26	40.64	39.67	39.07
57	41.89	41.26	40.27	39.67

COOLING CAPACITY

048

Outdoor Temperature - °F (Dry Bulb)	Indoor Temperature - °F (Dry Bulb / Wet Bulb)							
	65°F / 54°F		70°F / 59°F		75°F / 63°F		80°F / 67°F	
	Total mBtuh	Sensible mBtuh	Total mBtuh	Sensible mBtuh	Total mBtuh	Sensible mBtuh	Total mBtuh	Sensible mBtuh
-13	36.74	25.72	39.94	27.96	43.13	31.49	51.18	39.10
-5	38.68	27.08	42.04	29.43	45.40	33.14	53.87	41.15
-4	38.87	27.21	42.25	29.58	45.63	33.31	54.14	41.36
0	39.11	27.38	42.51	29.76	45.91	33.51	54.68	41.01
5	38.52	26.97	41.87	29.31	45.22	33.01	54.58	42.12
15	37.94	26.56	41.24	28.87	44.54	32.51	55.15	42.11
25	38.16	27.10	41.48	29.46	44.80	33.31	55.67	42.25
35	38.39	27.65	41.73	30.05	45.07	34.10	56.20	42.40
45	38.61	28.19	41.97	30.64	45.33	34.90	56.72	42.54
55	38.46	30.21	41.80	32.84	45.15	35.66	57.90	43.71
65	38.31	32.24	41.64	35.04	44.97	36.41	59.08	44.87
75	38.15	34.26	41.47	37.24	44.79	37.17	60.26	46.04
85	36.17	33.91	39.32	36.86	42.47	36.10	56.82	44.49
95	33.36	32.69	36.26	35.53	39.16	34.07	53.16	42.79
105	30.33	30.33	32.97	32.97	35.61	32.05	40.95	37.95
115	27.47	27.47	29.86	29.86	32.25	32.25	38.57	38.57
122	24.42	24.42	26.54	26.54	28.66	28.66	35.24	35.24

HEATING CAPACITY

048

Outdoor Temperature - °F (Dry Bulb)	Indoor Temperature - °F (Dry Bulb)			
	60°F	65°F	70°F	75°F
	Total mBtuh	Total mBtuh	Total mBtuh	Total mBtuh
-13	23.94	23.58	15.64	15.33
-5	25.31	24.93	17.45	17.10
0	27.13	26.72	24.88	24.38
5	29.48	29.04	24.123	25.60
17	33.67	33.16	30.07	29.47
19.4	34.15	33.64	30.42	29.81
24.8	36.61	36.06	35.94	35.22
32	40.56	39.95	38.56	37.79
35	44.08	43.42	42.09	41.25
39.2	50.41	49.66	48.96	47.98
44.6	56.74	55.89	55.83	54.71
47	57.87	57.01	56.95	55.80
53.6	66.65	65.65	64.75	63.46
57	67.67	66.65	65.74	64.43

MWMA009S4 AND MWMB009S4 - COOLING

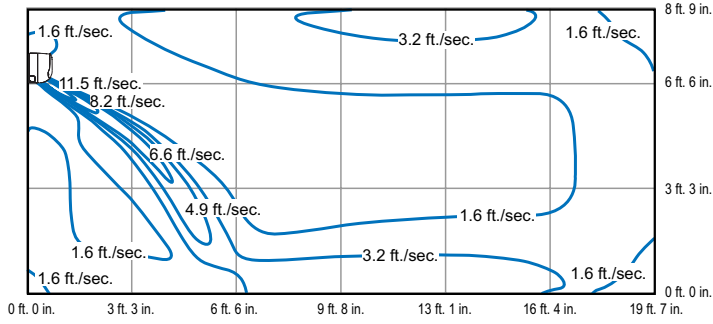

MWMA009S4 AND MWMB009S4 - HEATING

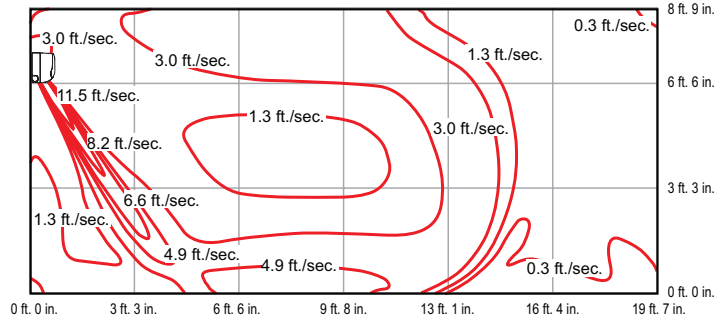

MWMA012S4 AND MWMB012S4 - COOLING

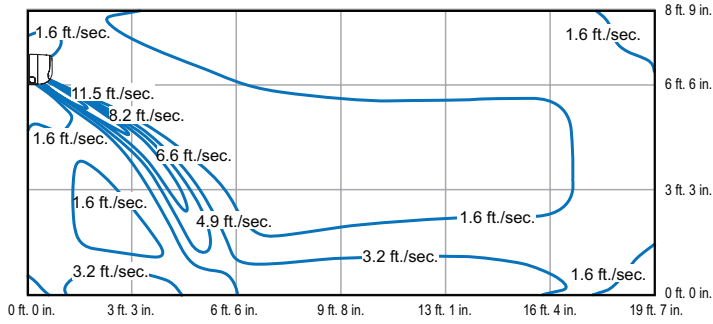

MWMA012S4 AND MWMB012S4 - HEATING

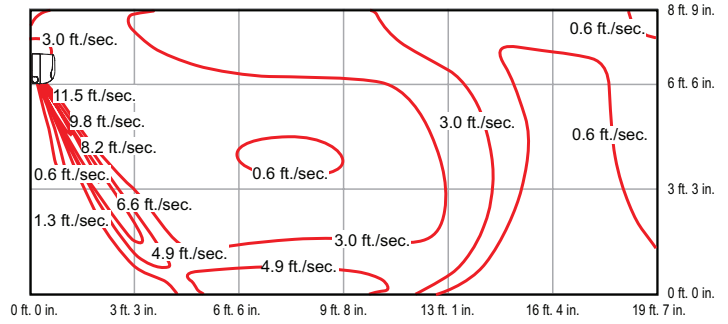

MWMA018S4 - COOLING

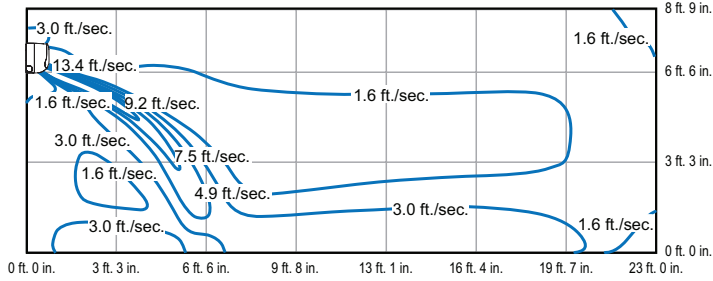

MWMA018S4 - HEATING

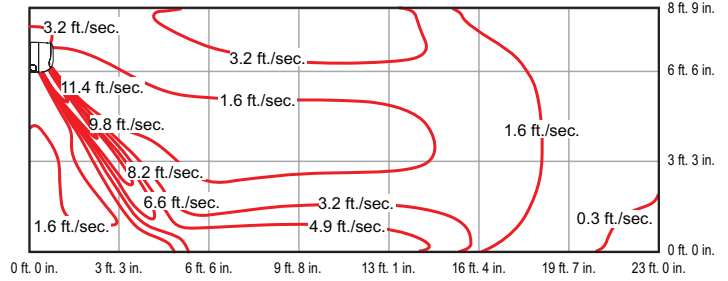

MWMA024S4 - COOLING

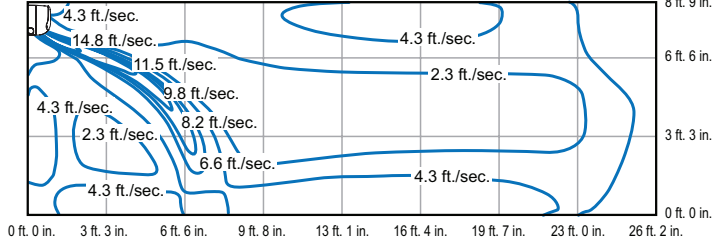

MWMA024S4 - HEATING

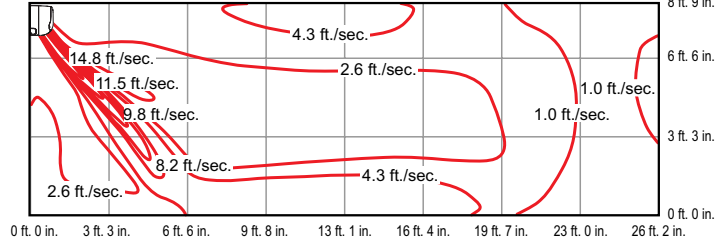

AIR THROW DATA

CASSETTE INDOOR UNITS

M22A009S4 AND M22A012S4 - COOLING

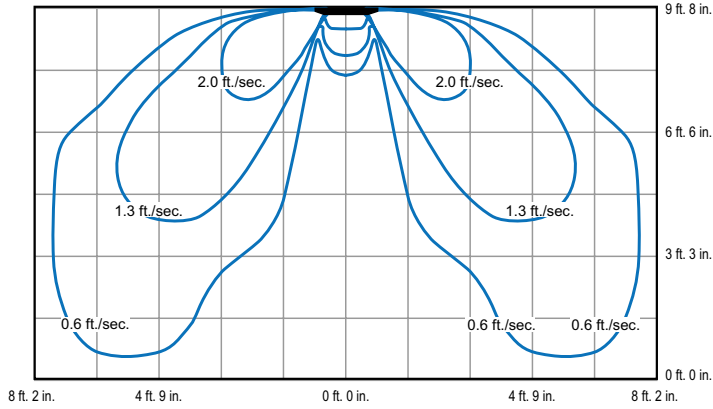

M22A009S4 AND M22A012S4 - HEATING

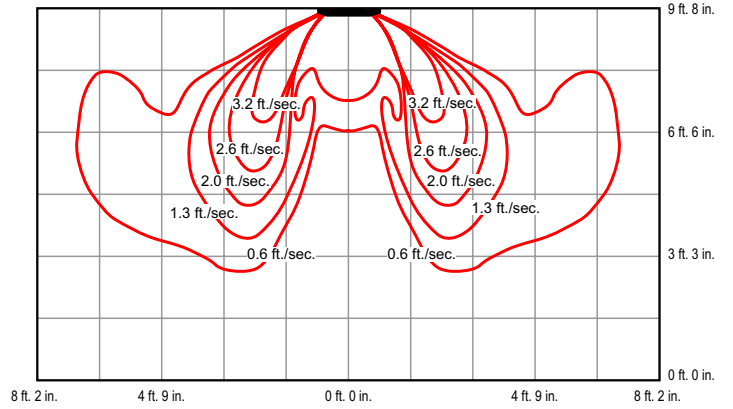

M22A018S4 - COOLING

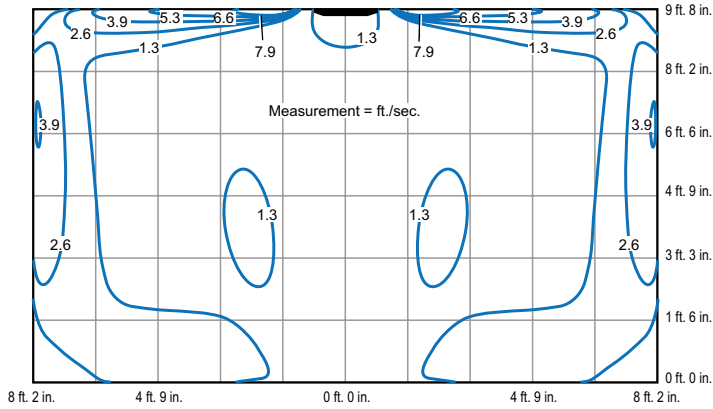

M22A018S4 - HEATING

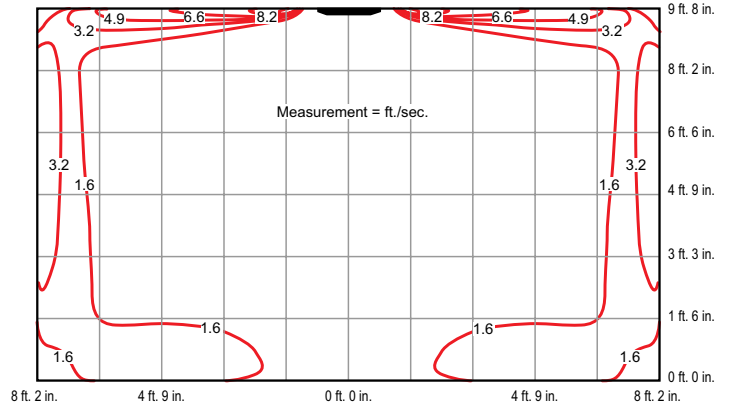

M33A024S4 - COOLING

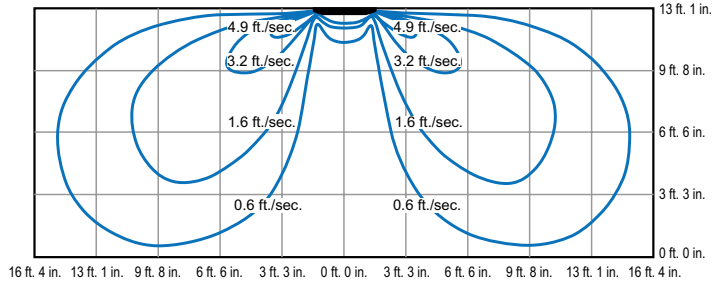

M33A024S4 - HEATING

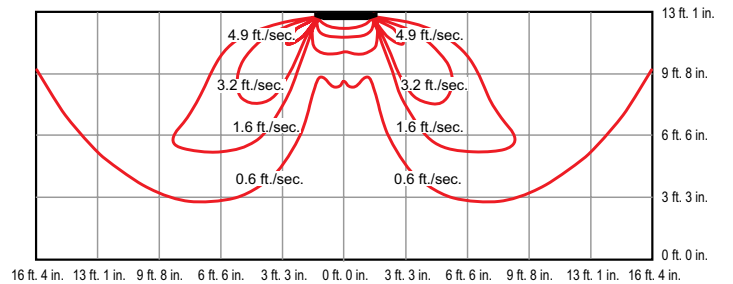

AIR THROW DATA

CEILING/FLOOR MOUNT INDOOR UNITS

MCFB018S4 AND MCFA024S4 - COOLING - CEILING

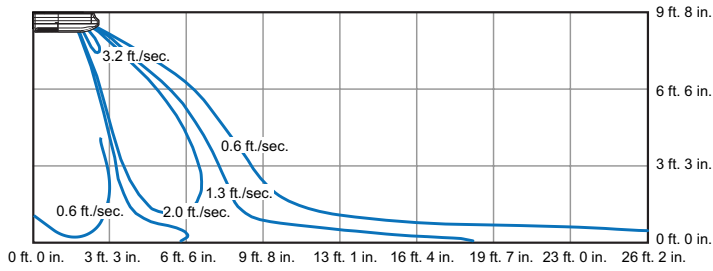

MCFB018S4 AND MCFA024S4 - HEATING - CEILING

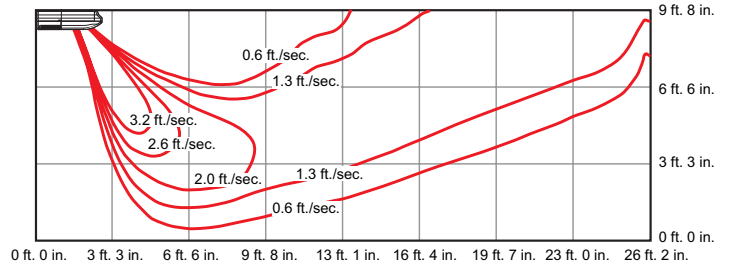

MCFB018S4 AND MCFA024S4 - COOLING - FLOOR

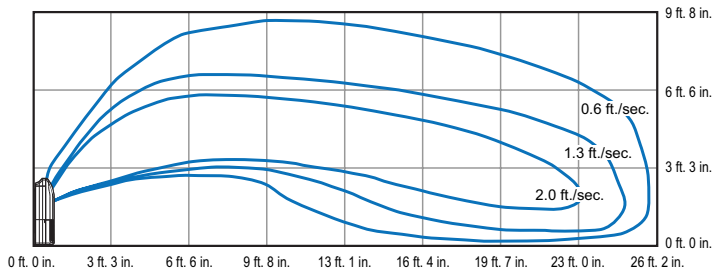

MCFB018S4 AND MCFA024S4 - HEATING - FLOOR

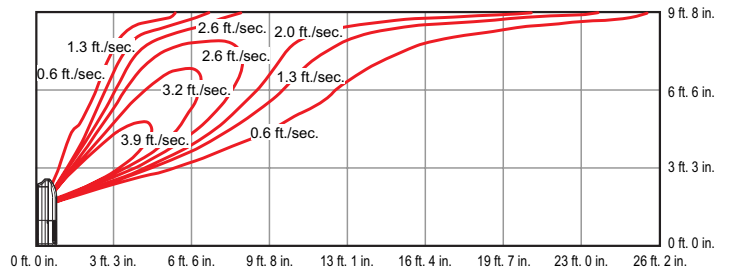

AIR THROW DATA - FLOOR MOUNT CONSOLE INDOOR UNITS

MFMA012S4 - COOLING - FLOOR

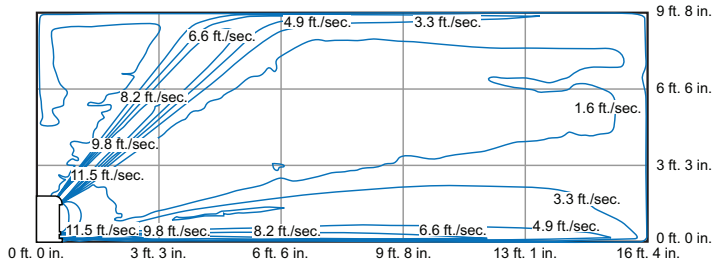

MFMA012S4 - HEATING - FLOOR

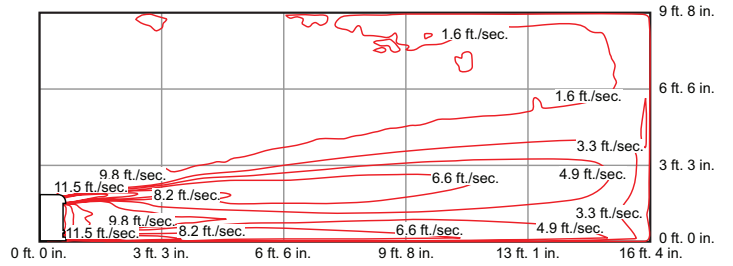

MMDB009S4

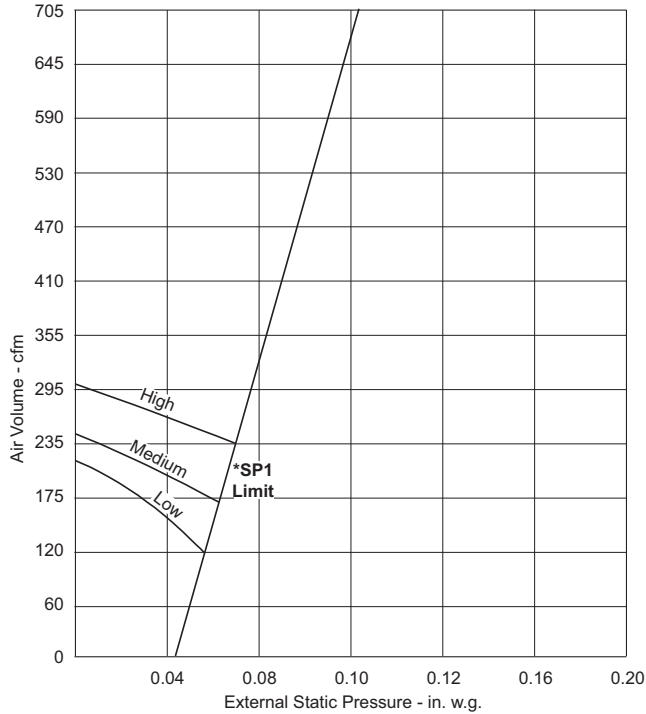

**SP1 Limit airflow rate setting on the controller.*

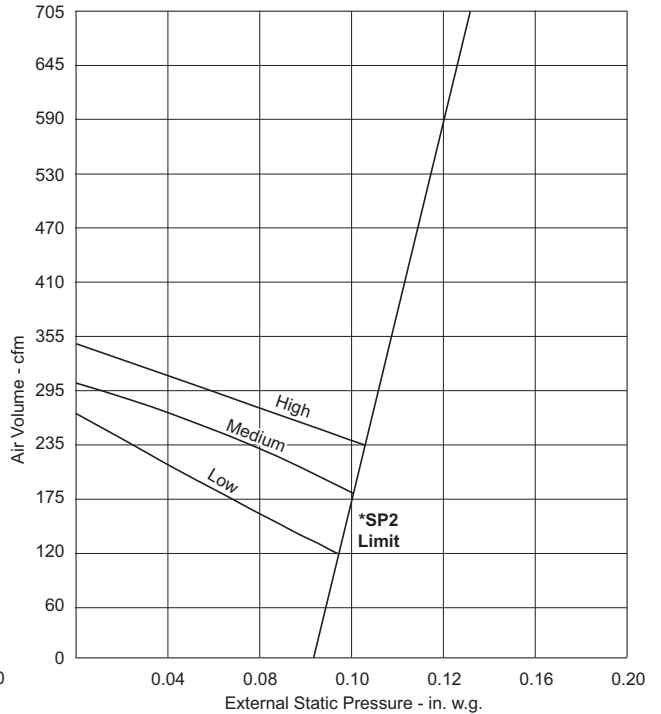

**SP2 Limit airflow rate setting on the controller.*

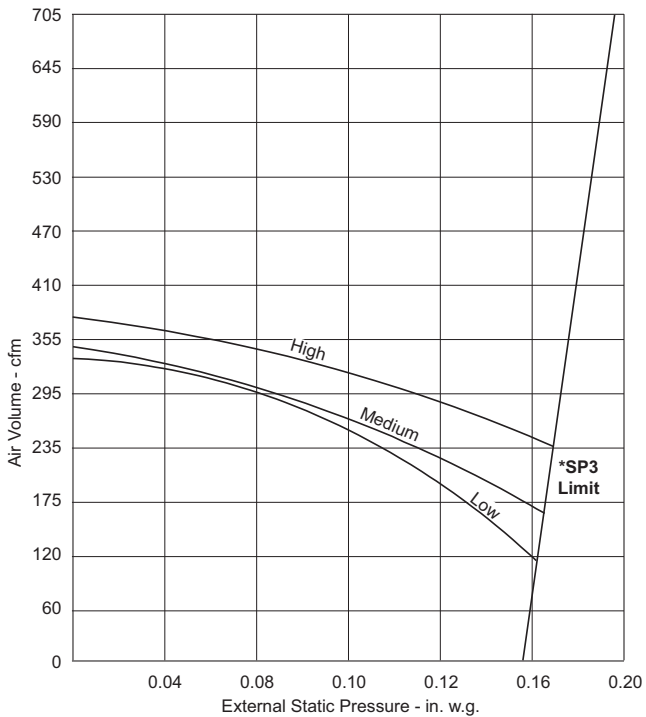

**SP3 Limit airflow rate setting on the controller.*

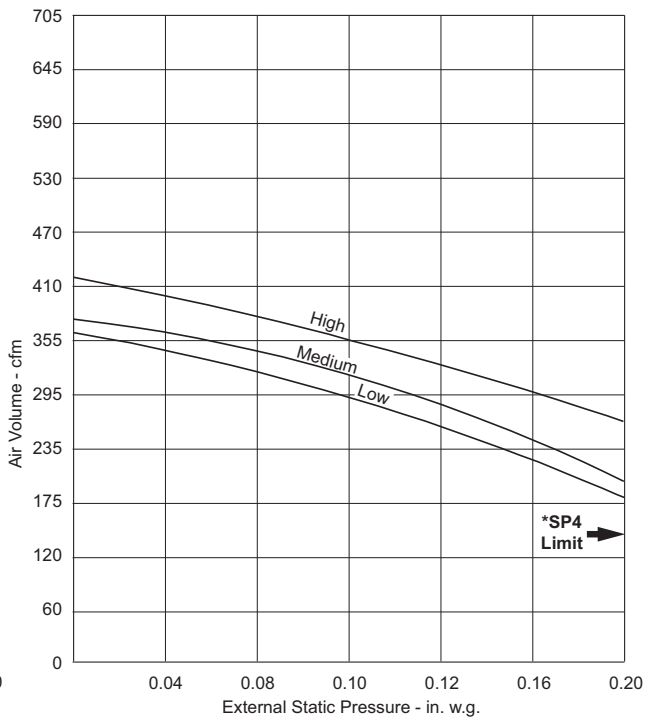

**SP4 Limit airflow rate setting on the controller.*

MMDB012S4

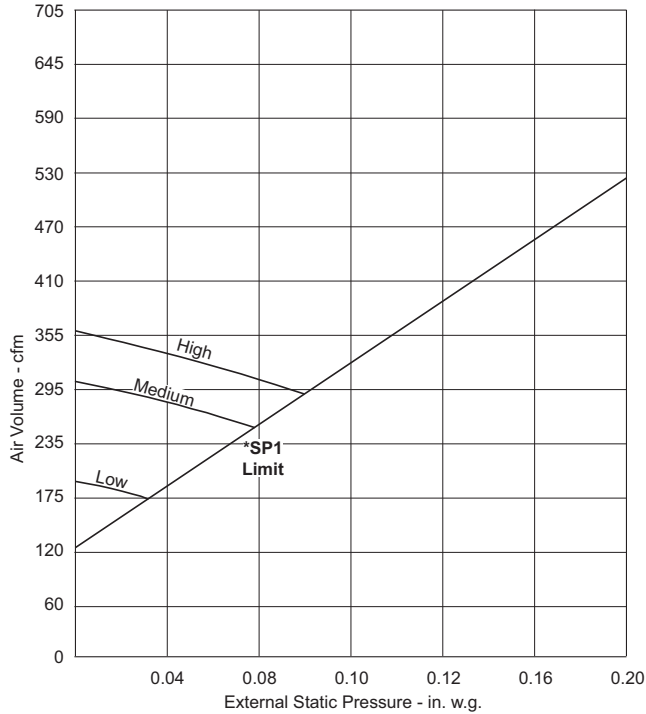

*SP1 Limit airflow rate setting on the controller.

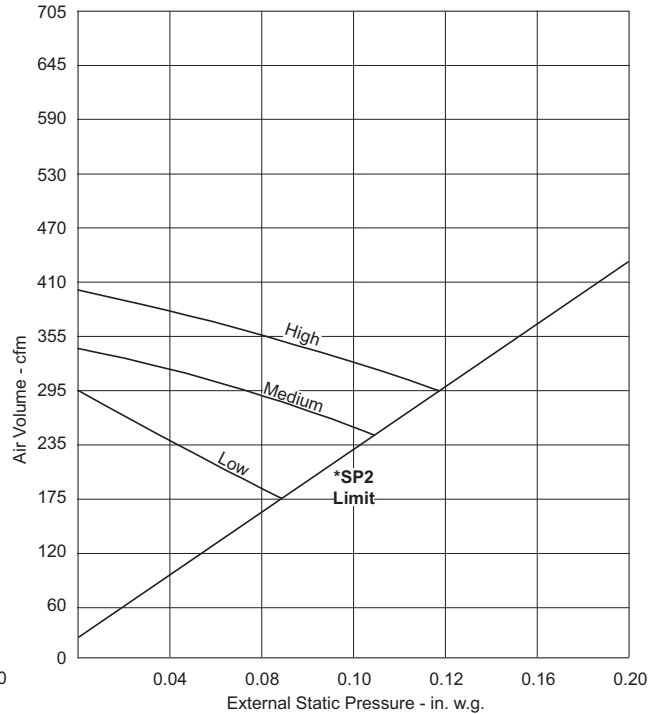

*SP2 Limit airflow rate setting on the controller.

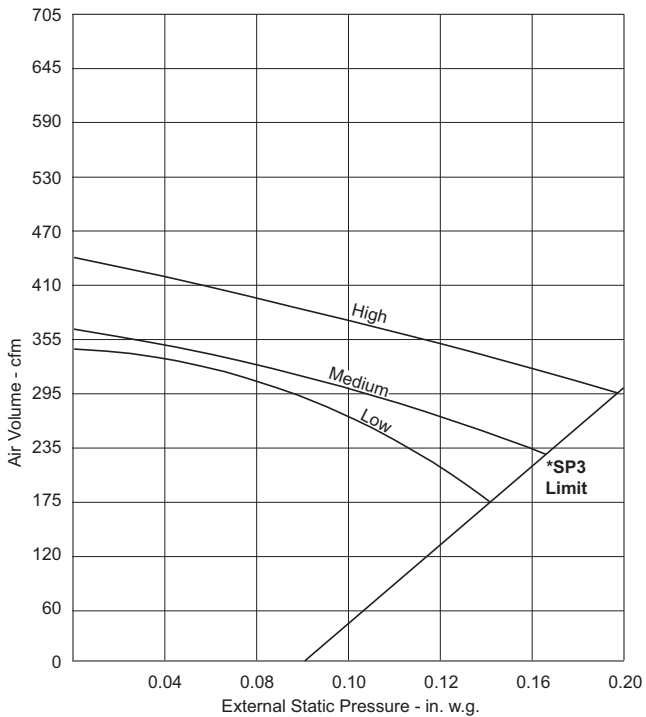

*SP3 Limit airflow rate setting on the controller.

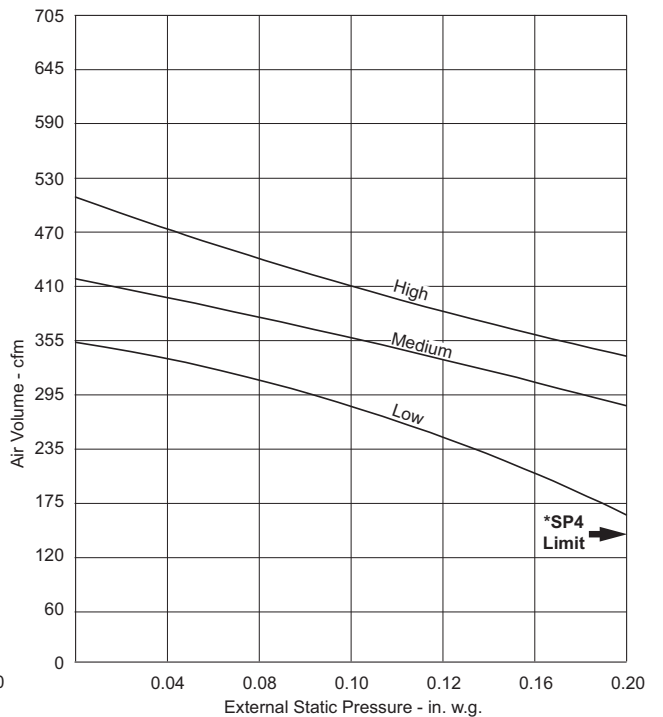

*SP4 Limit airflow rate setting on the controller.

MMDB018S4

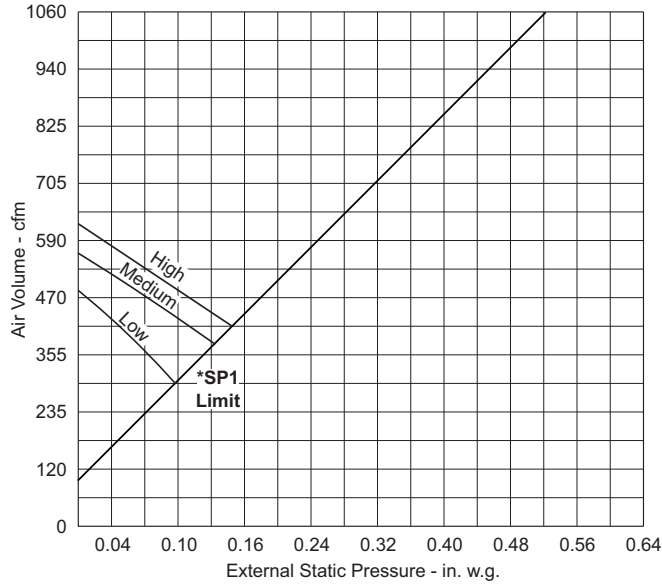

**SP1 Limit airflow rate setting on the controller.*

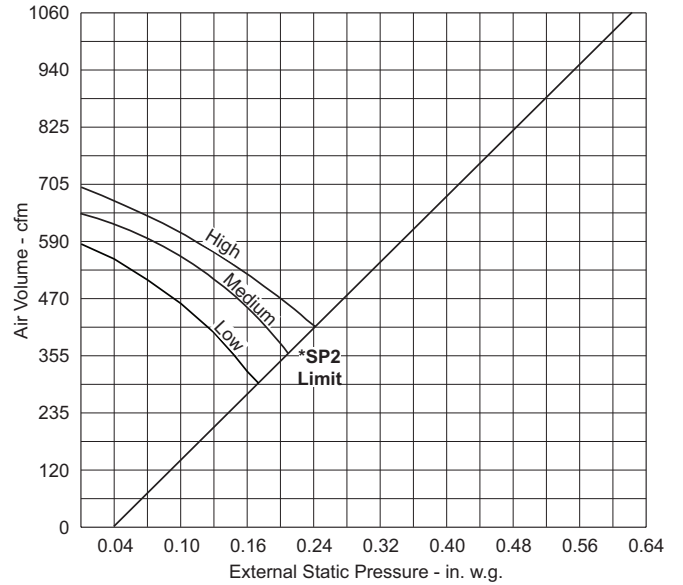

**SP2 Limit airflow rate setting on the controller.*

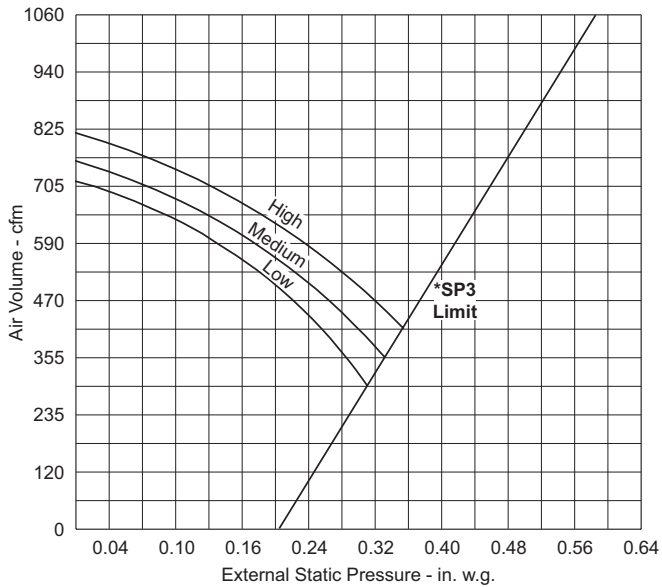

**SP3 Limit airflow rate setting on the controller.*

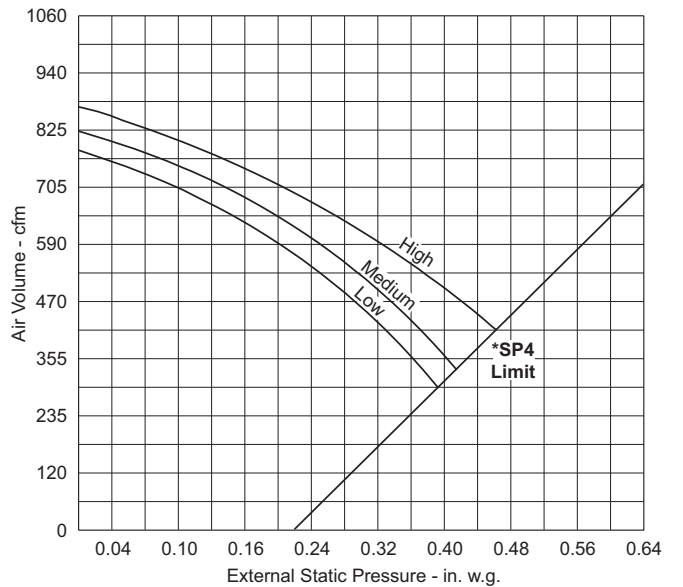

**SP4 Limit airflow rate setting on the controller.*

MMDB024S4

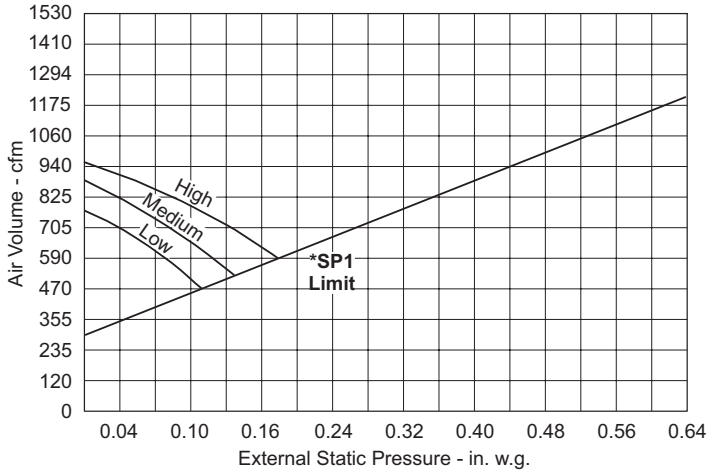

**SP1 Limit airflow rate setting on the controller.*

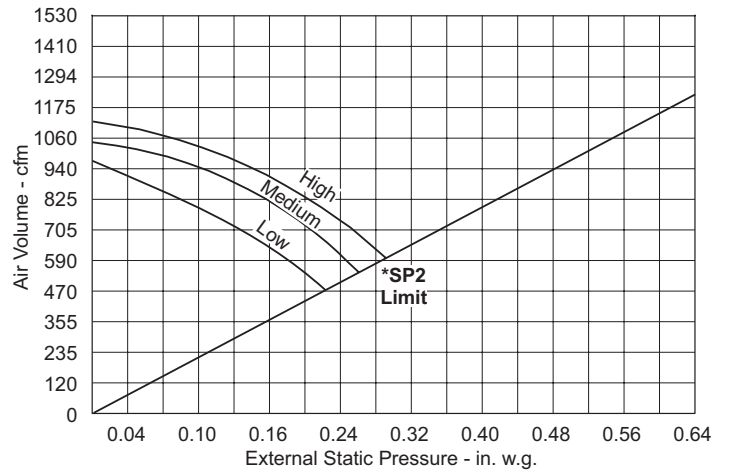

**SP2 Limit airflow rate setting on the controller.*

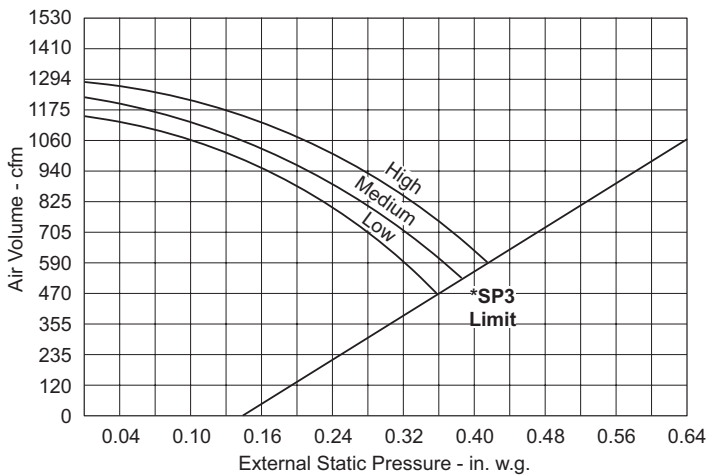

**SP3 Limit airflow rate setting on the controller.*

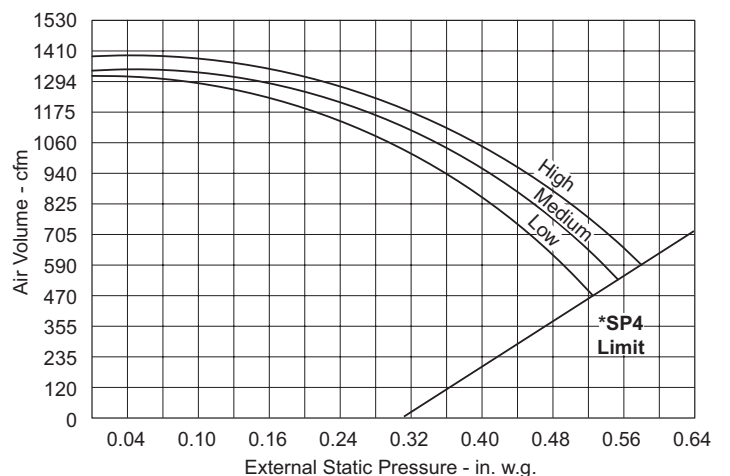

**SP4 Limit airflow rate setting on the controller.*

MPB018S4M

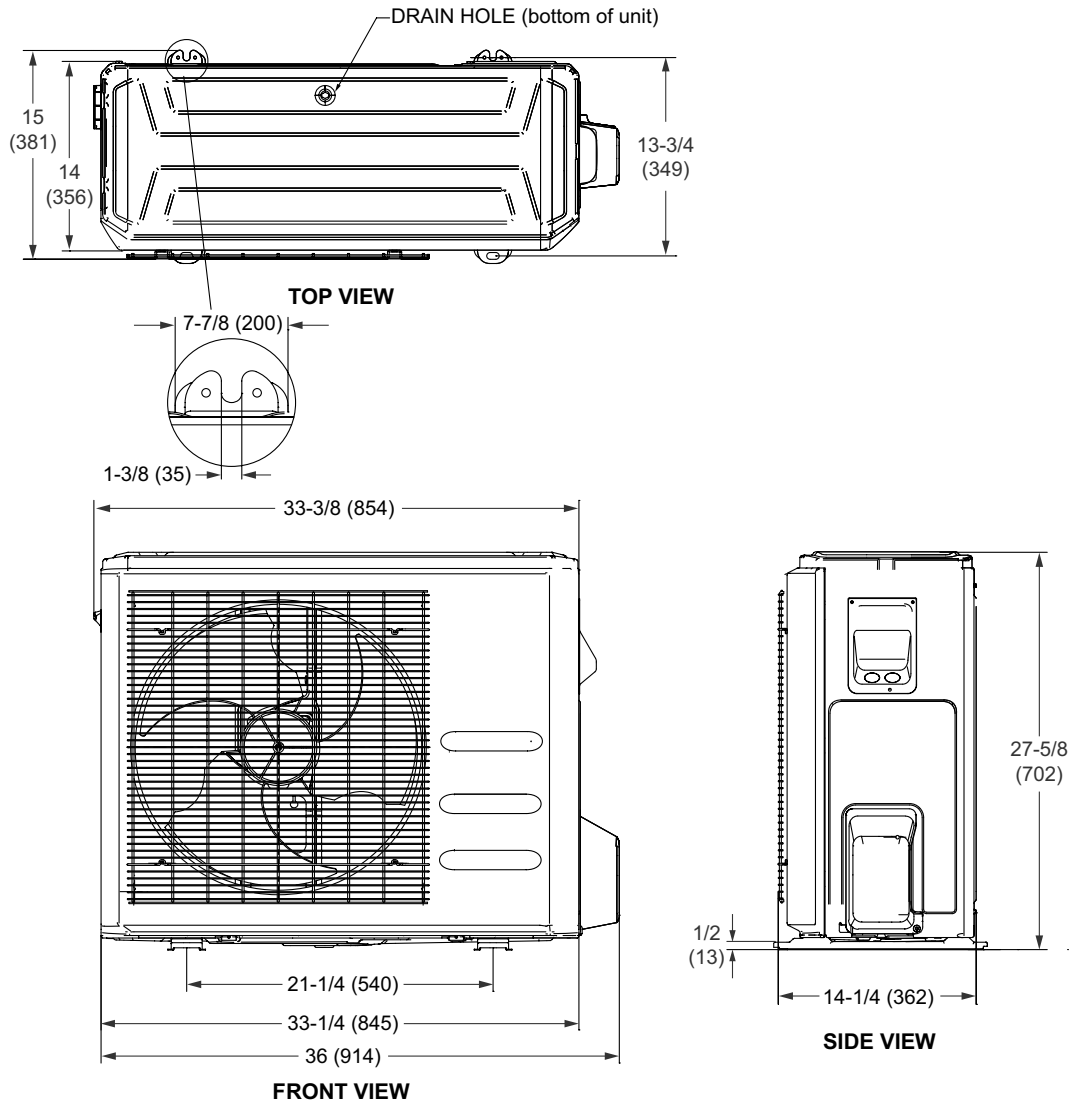

MPB030S4M, MPB036S4M

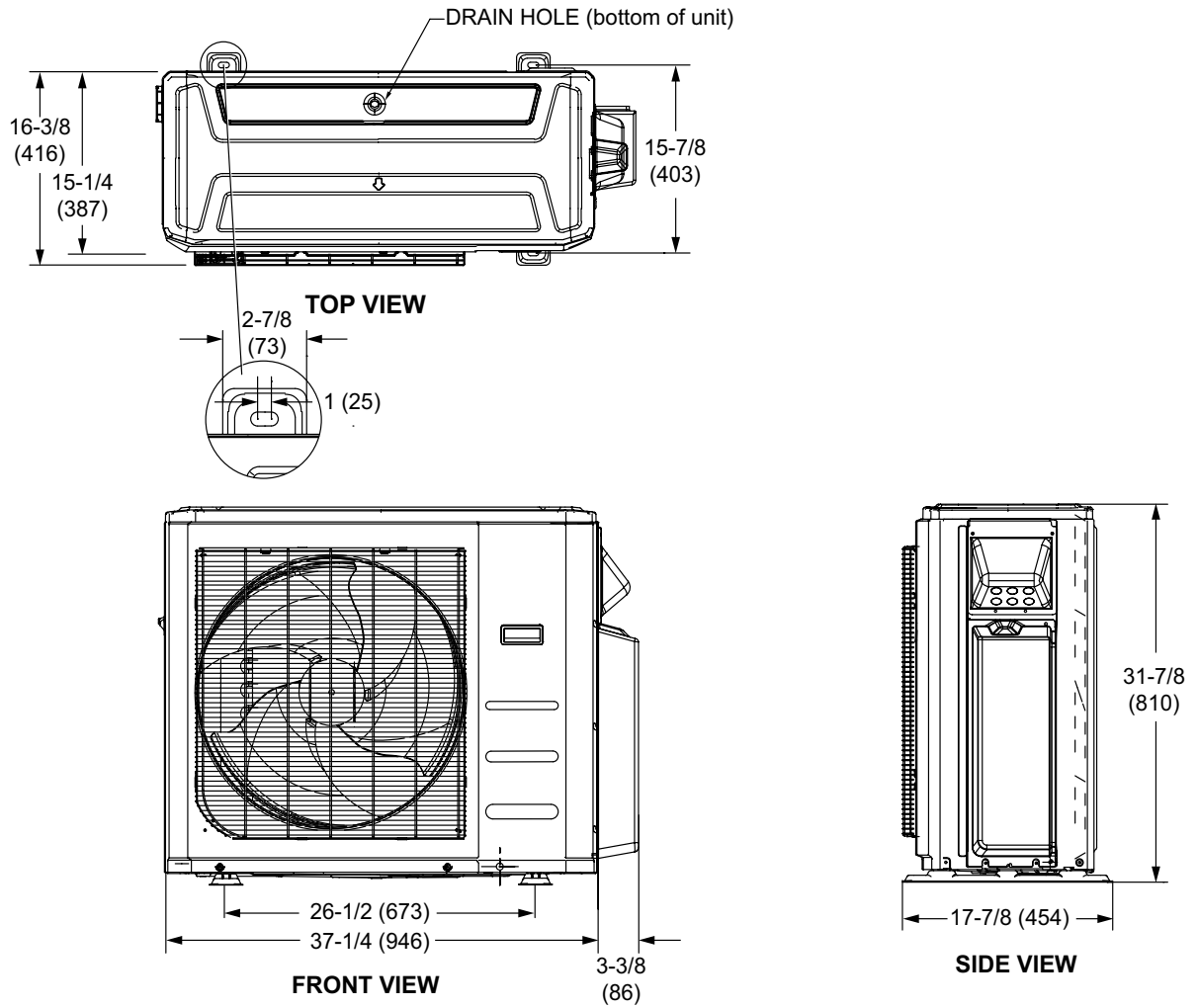

MPB048S4M

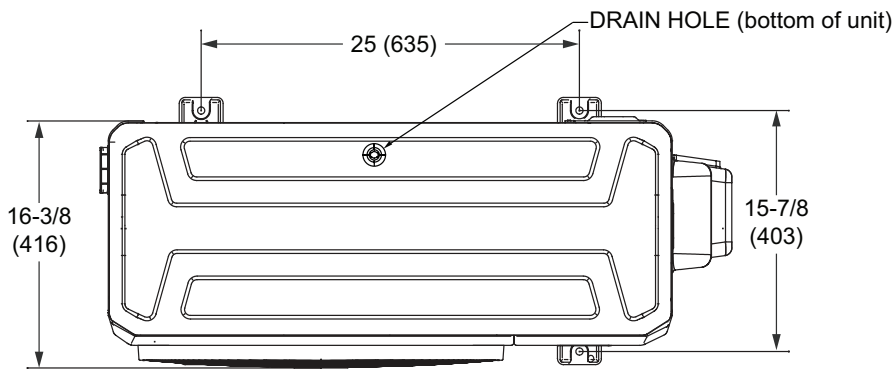

TOP VIEW

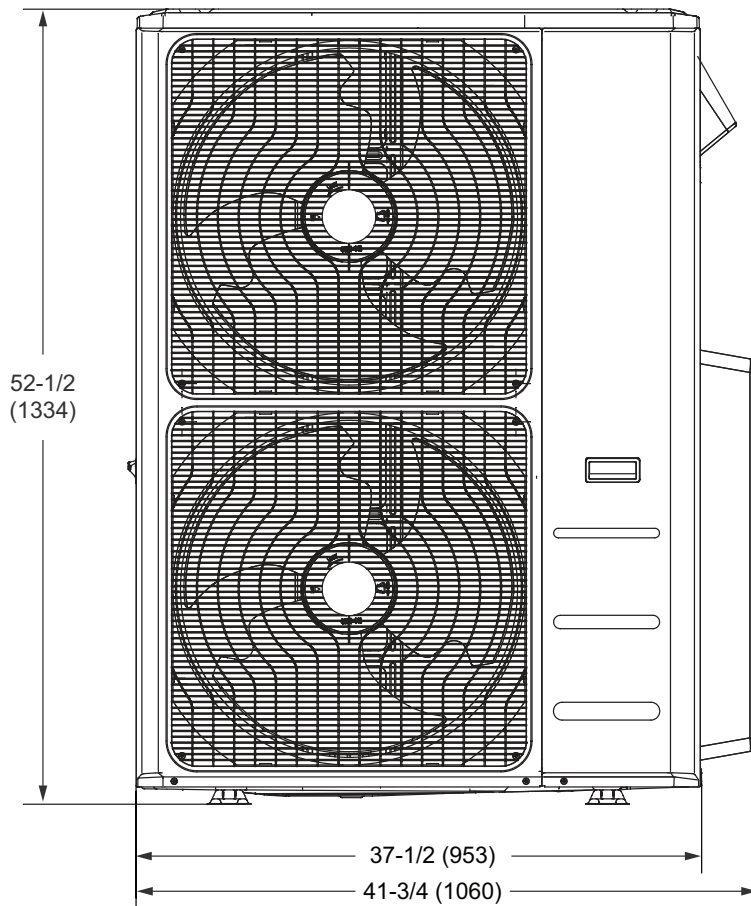

FRONT VIEW

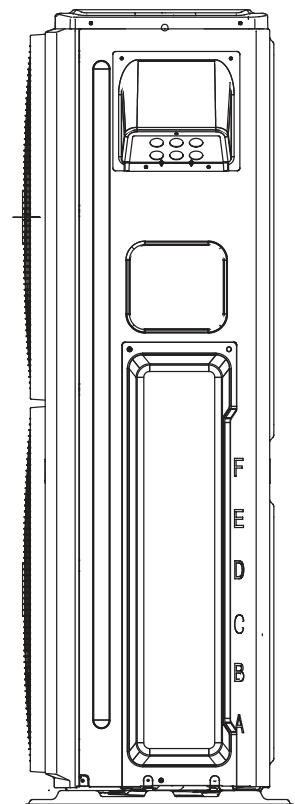

SIDE VIEW

MWMA009S4, MWMA012S4, MWMA018S4, MWMA024S4

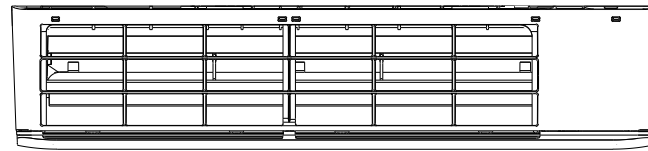

TOP VIEW

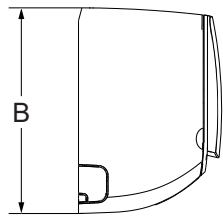

SIDE VIEW

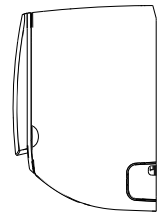
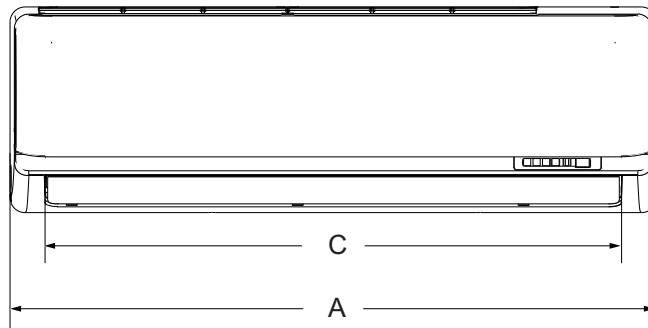

SIDE VIEW

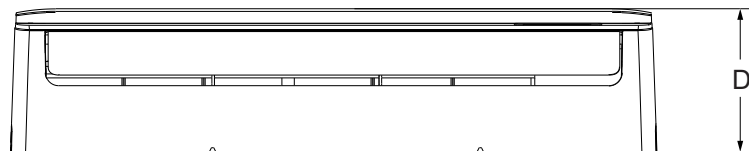

BOTTOM VIEW

Size	A		B		C		D	
	in.	mm	in.	mm	in.	mm	in.	mm
MWMA009, 012	33-1/8	841	11	279	29-1/4	743	8-1/4	210
MWMB009, 012	32-7/8	835	11	279	29-1/4	743	7-7/8	200
MWMA018	39	991	12-3/8	314	34-3/4	883	8-5/8	219
MWMA024	46-3/4	1187	13-1/2	343	42-1/2	1080	10-1/4	260

MWMA009S4 and MWMA012S4

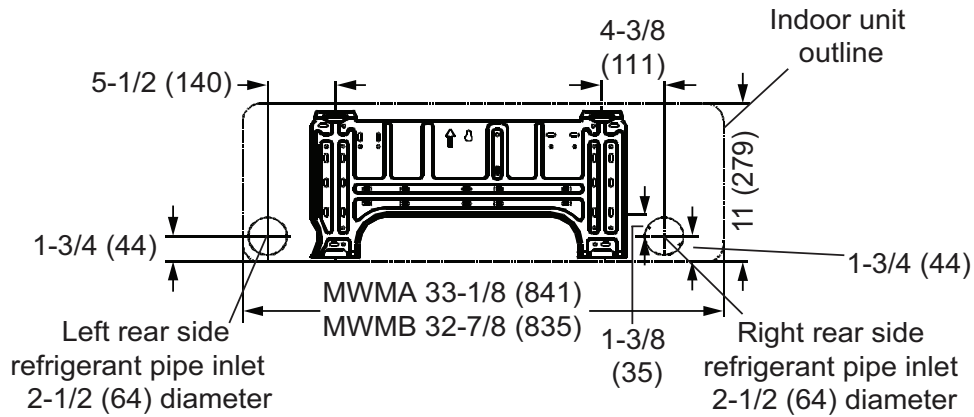

MWMA018S4

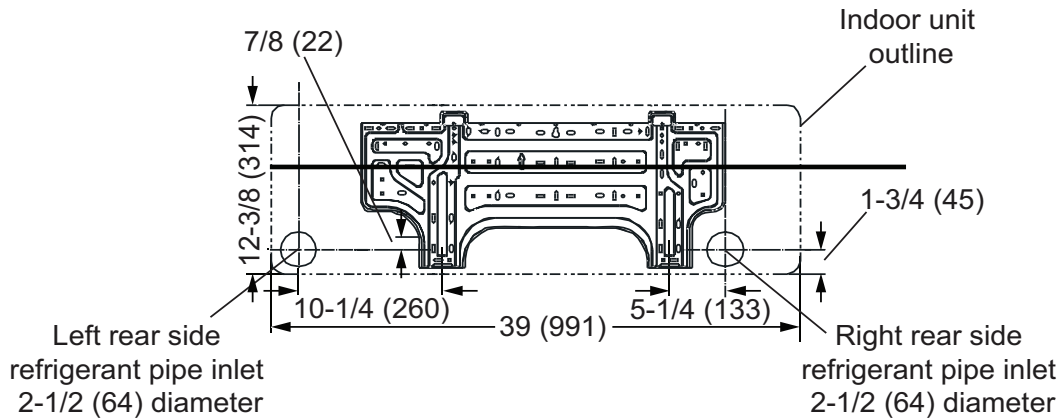

MWMA024S4

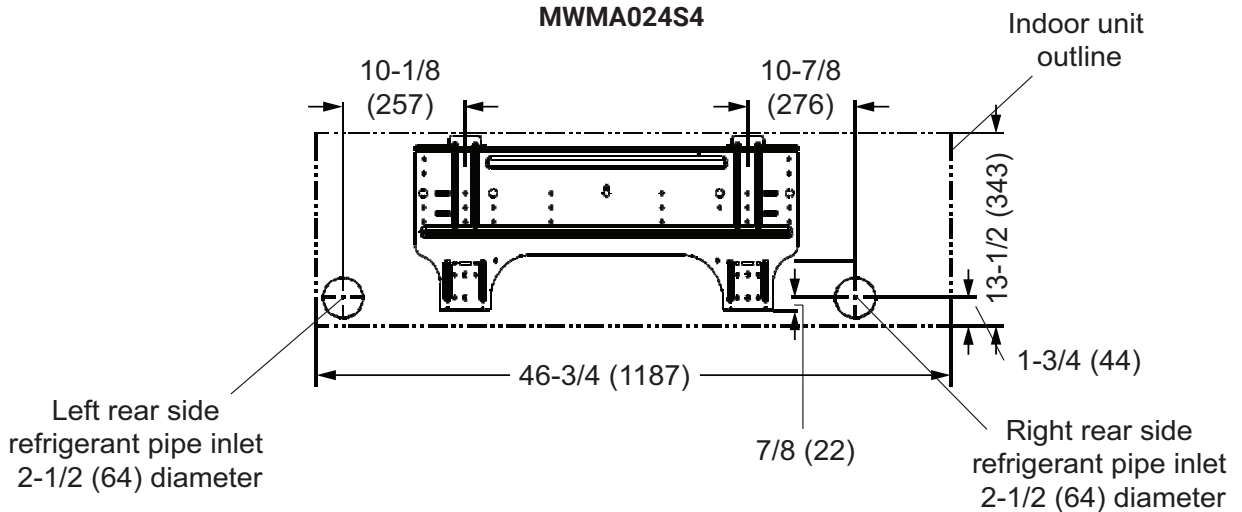

M22A009S4, M22A012S4, M22A018S4

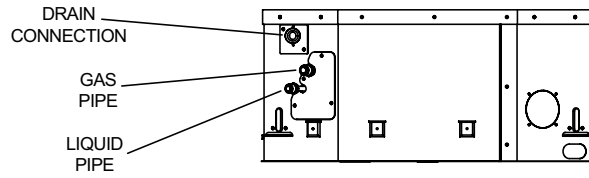

SIDE VIEW

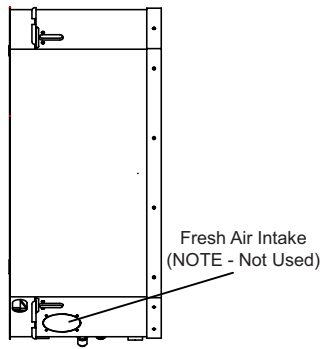

LEFT SIDE VIEW

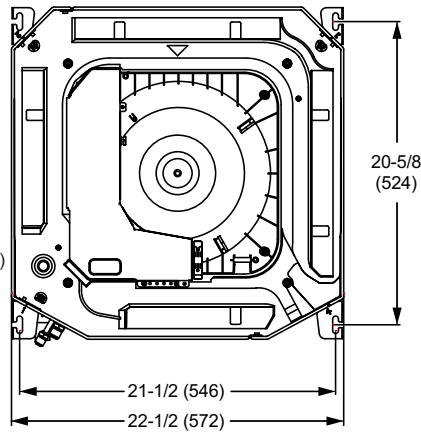

BOTTOM VIEW (Body)

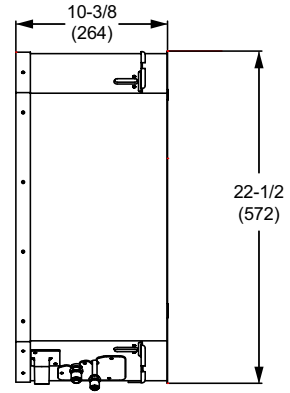

RIGHT SIDE VIEW

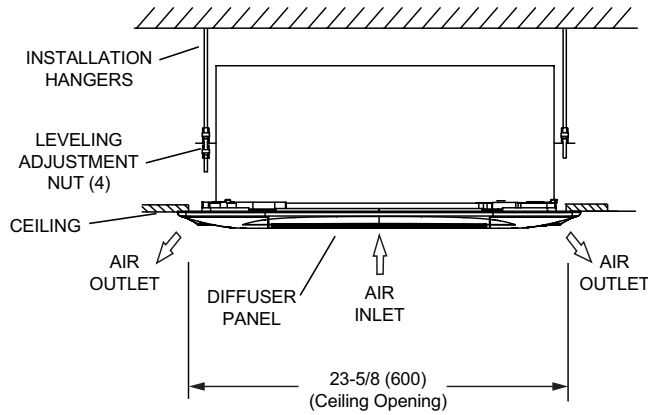

SIDE VIEW

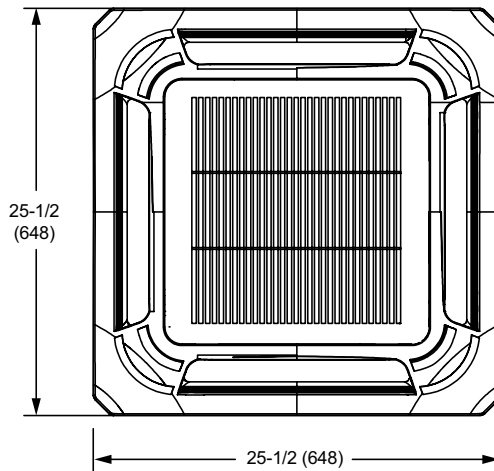

BOTTOM VIEW (Panel)

M33024S4

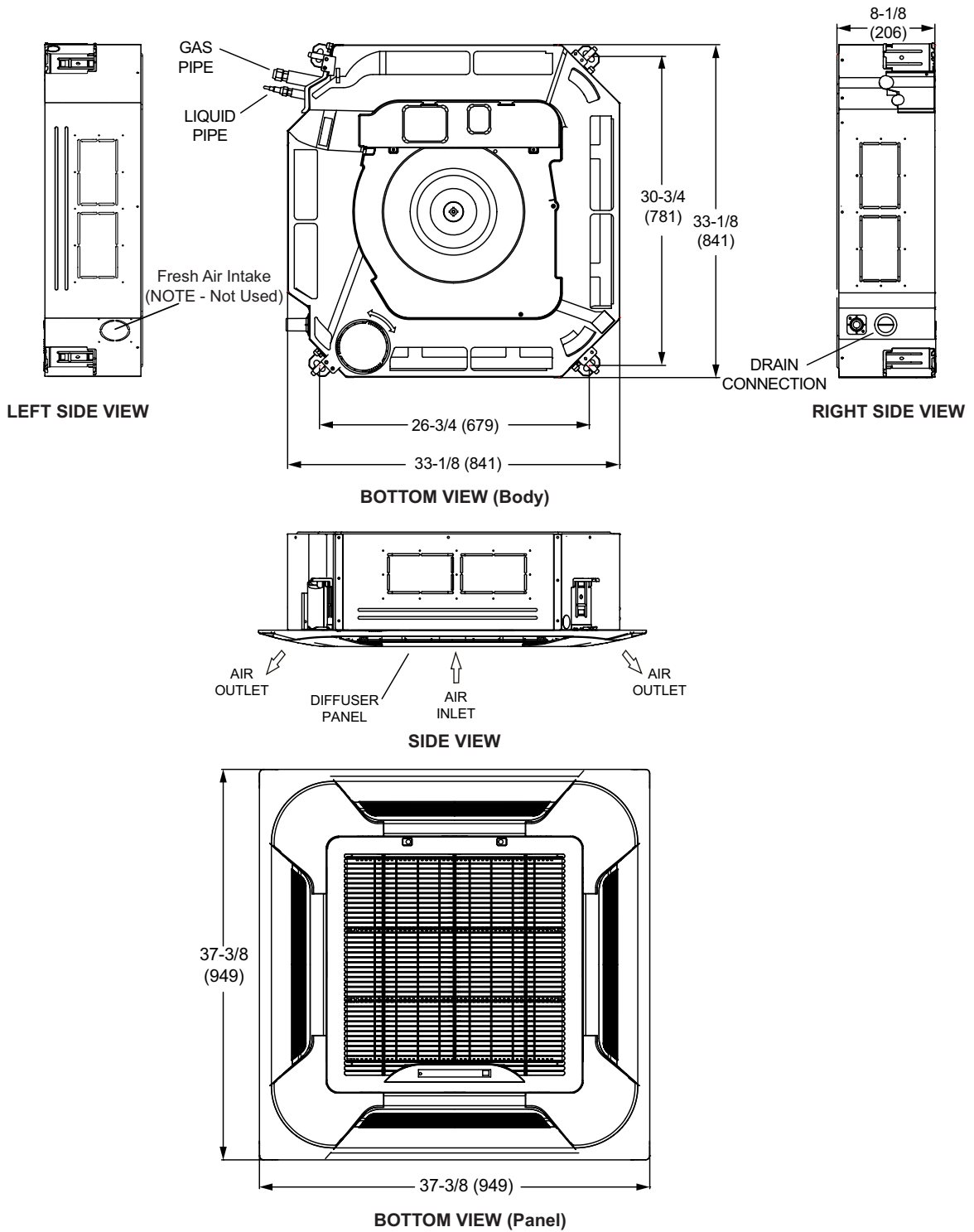

DIMENSIONS

CEILING/FLOOR MOUNT INDOOR UNITS

MCFB018S4, MCFA024S4

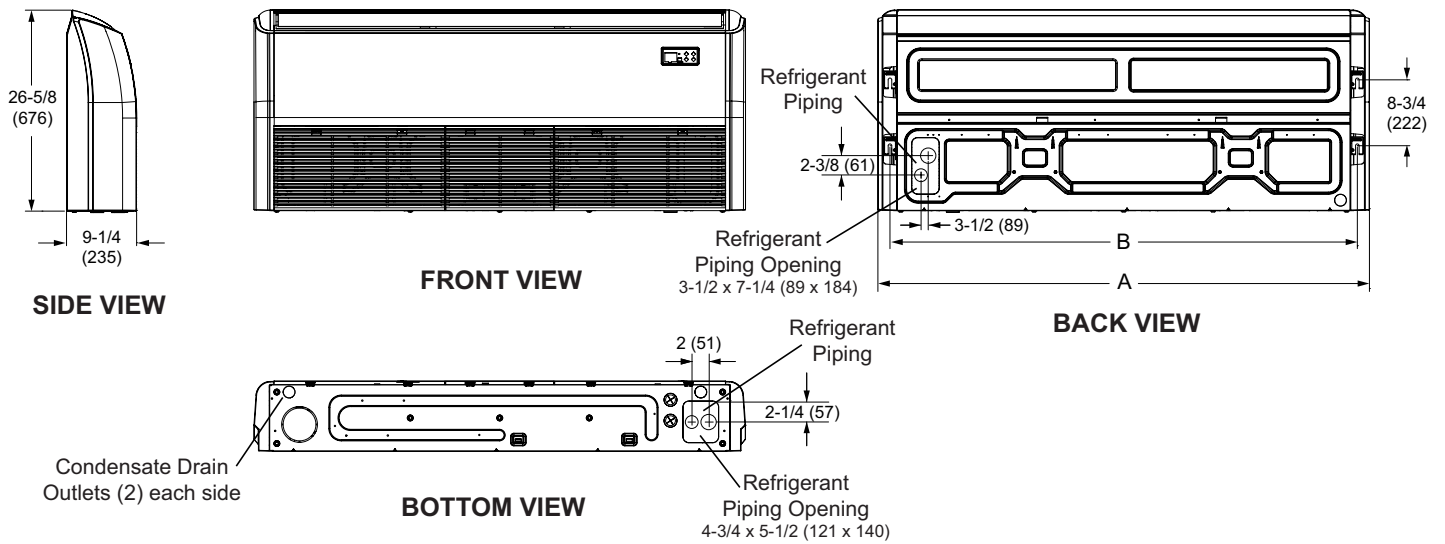

Model No.	A		B	
	in.	mm	in.	mm
018	42	1067	37	940
024	42-1/8	1070	39	991

DIMENSIONS

FLOOR MOUNT CONSOLE INDOOR UNIT

MFMA012S4

MFMA012S4

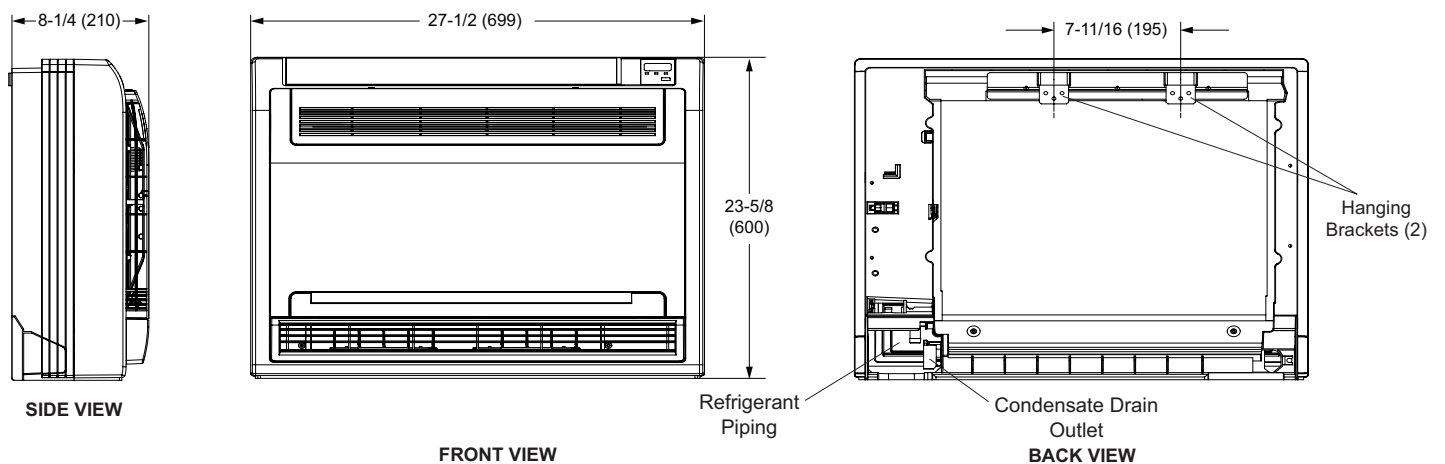

MMDB009S4, MMDB012S4, MMDB018S4, MMDB024S4

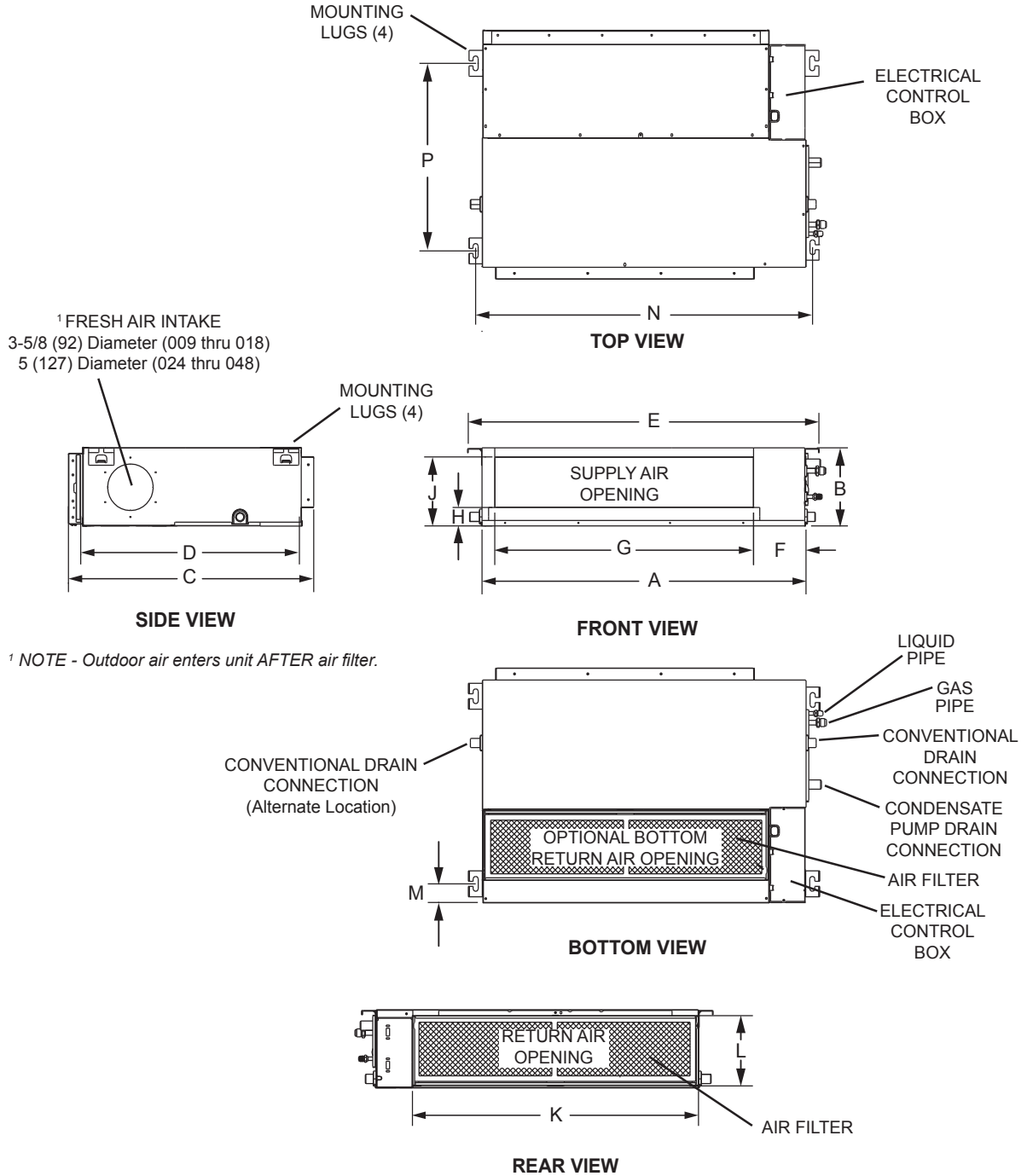

Size	A		B		C		D		E		F		G		H	
	in.	mm	in.	mm	in.	mm	in.	mm	in.	mm	in.	mm	in.	mm	in.	mm
009 thru 012	27-5/8	702	7-7/8	200	19-7/8	505	17-3/4	451	30-3/4	781	5-3/8	137	21-1/8	537	1-1/8	29
018	34-5/8	879	8-1/4	210	26-1/2	673	23-5/8	600	37-7/8	962	5-1/2	140	27-3/4	705	2	51
024	43-1/4	1099	9-3/4	248	30-1/2	775	27-1/2	699	46-1/2	1181	5-1/2	140	36-1/2	927	2	51

Size	J		K		L		M		N		P	
	in.	mm	in.	mm	in.	mm	in.	mm	in.	mm	in.	mm
009 thru 012	6	152	23-5/8	600	7-3/8	187	2	51	29-1/8	740	14-1/8	359
018	5-3/8	137	30-3/4	781	7-1/2	191	1-5/8	41	36-1/4	921	20	508
024	6-7/8	175	39-3/8	1000	9	229	1/4	6	44-7/8	1140	23-1/2	597

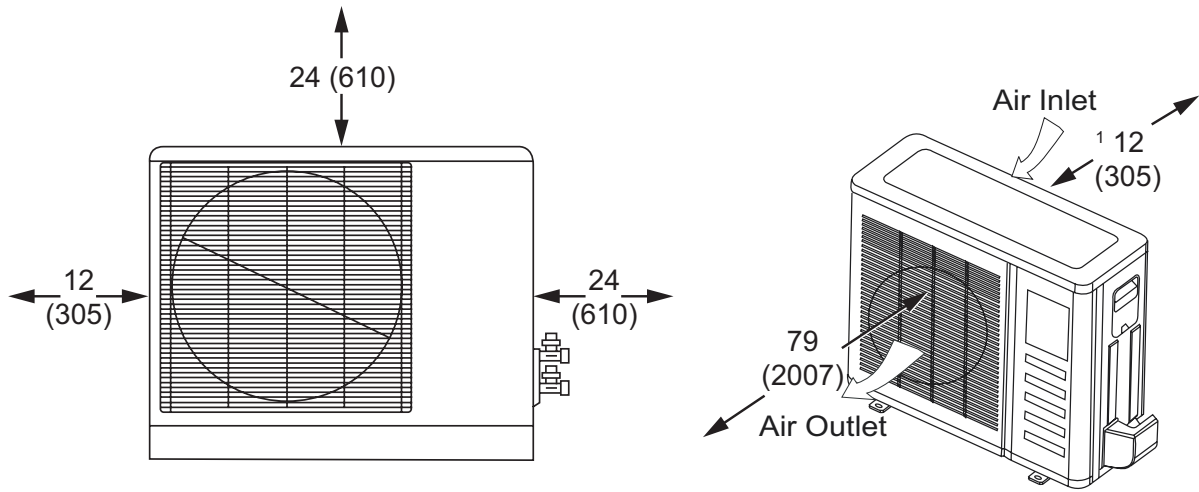

¹ Minimum rear clearance can be 6 inches (152 mm) when mounted on brackets and with no obstructions on the other three sides.

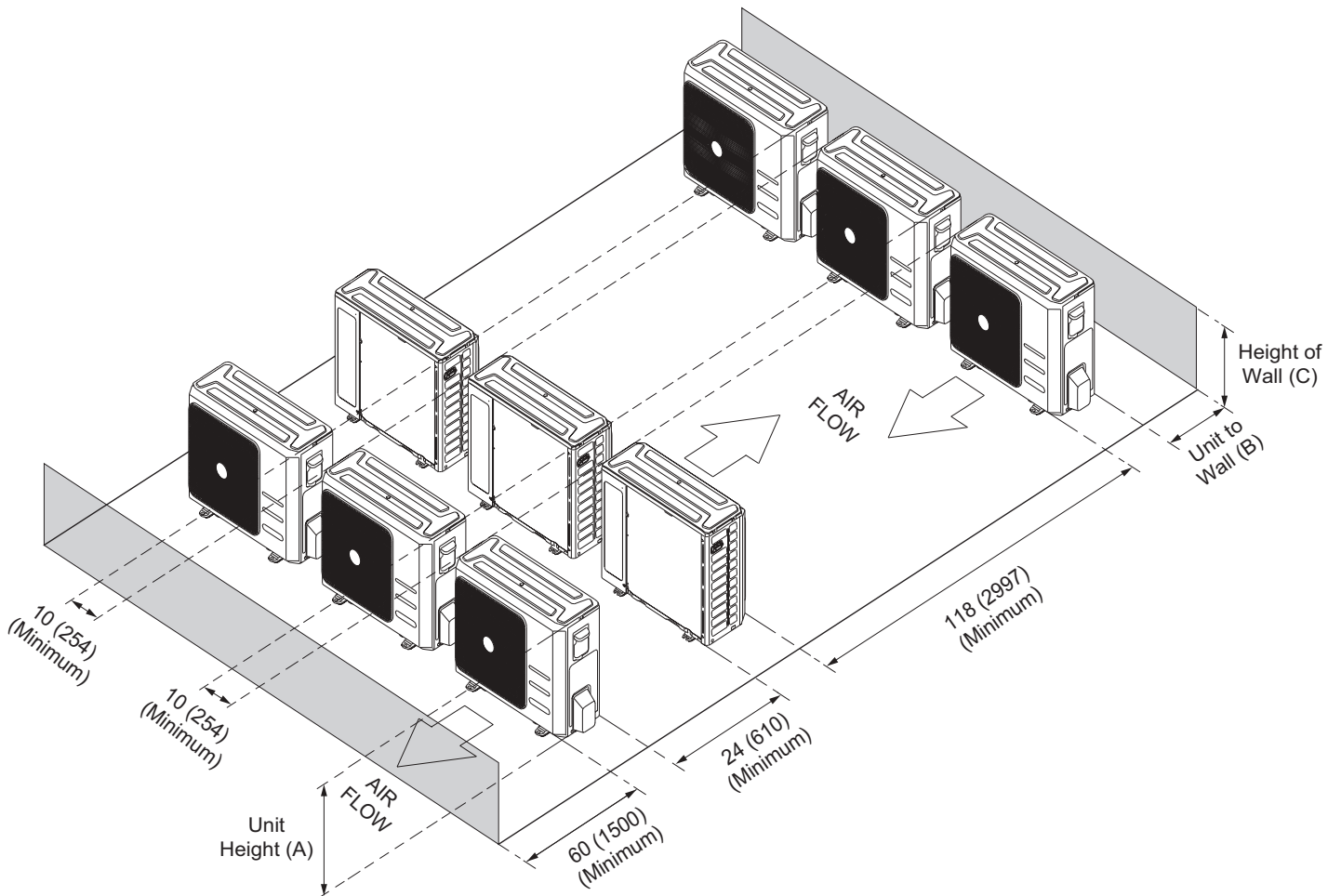

CLEARANCE NOTES FOR MULTIPLE UNITS:

If the height of the wall (C) is less than or equal to the height of the smallest unit (A), the distance from the unit to the wall (B) must be a minimum of 10 inches (254 mm).

If 1/2 the height of the unit (A) is less than the height of the wall (C), the distance from the unit to the wall (B) must be a minimum of 12 inches (305 mm).

If the height of the wall (C) is greater than the height of the unit (A), the distance from the unit to the wall (B) must be a minimum of 20 inches (508 mm).

INSTALLATION CLEARANCES

WALL-MOUNTED INDOOR UNITS

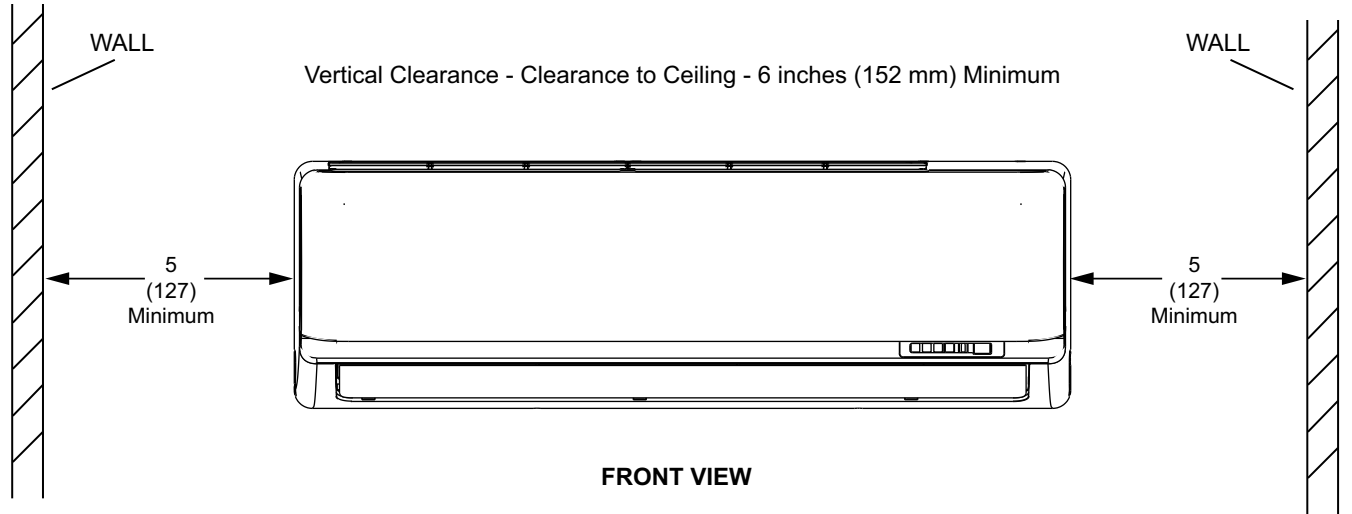

Vertical Clearance - Clearance to Floor - 72 inches (1829 mm) Minimum
NOTE - Provide 96 inches (2438) clearance to floor for best performance

INSTALLATION CLEARANCES

CASSETTE INDOOR UNITS

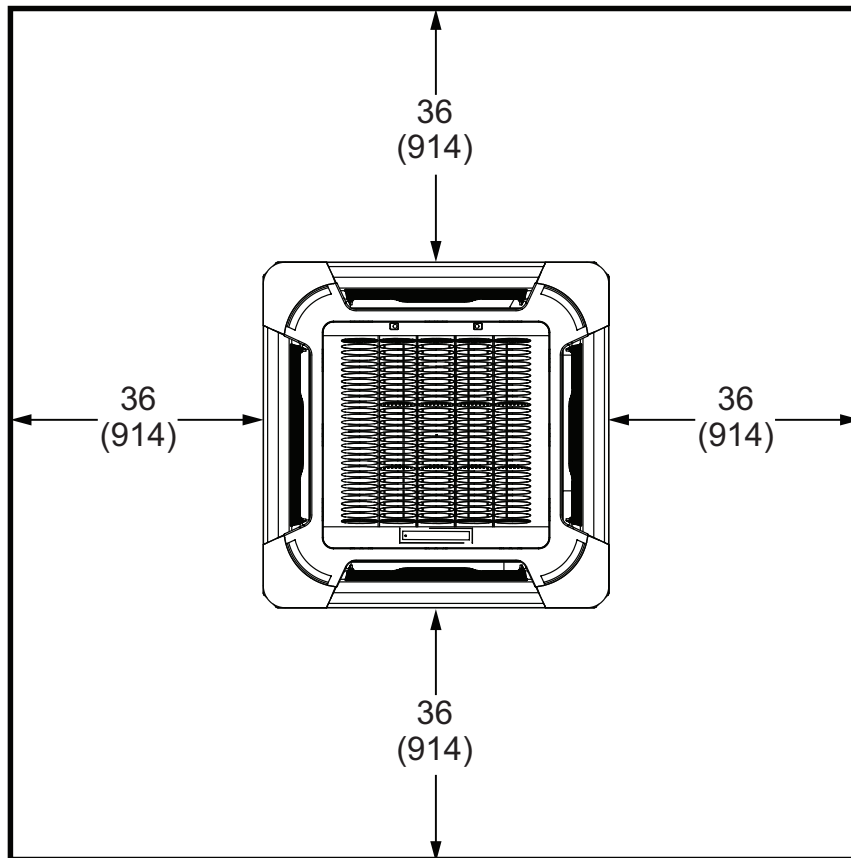

Minimum Vertical Clearances:
Minimum Clearance from Structural Ceiling to Drop Ceiling - 10-1/4 inches (260 mm)
Minimum Clearance to Floor - 98-1/2 inches (2500 mm)

CEILING APPLICATIONS

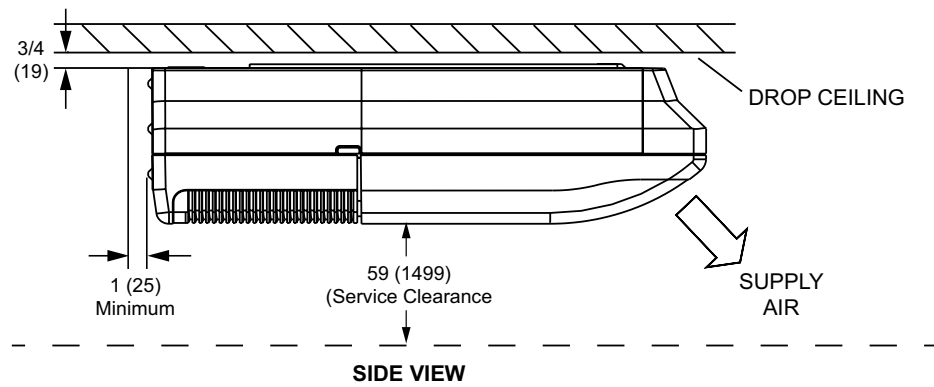

CEILING AND FLOOR APPLICATIONS

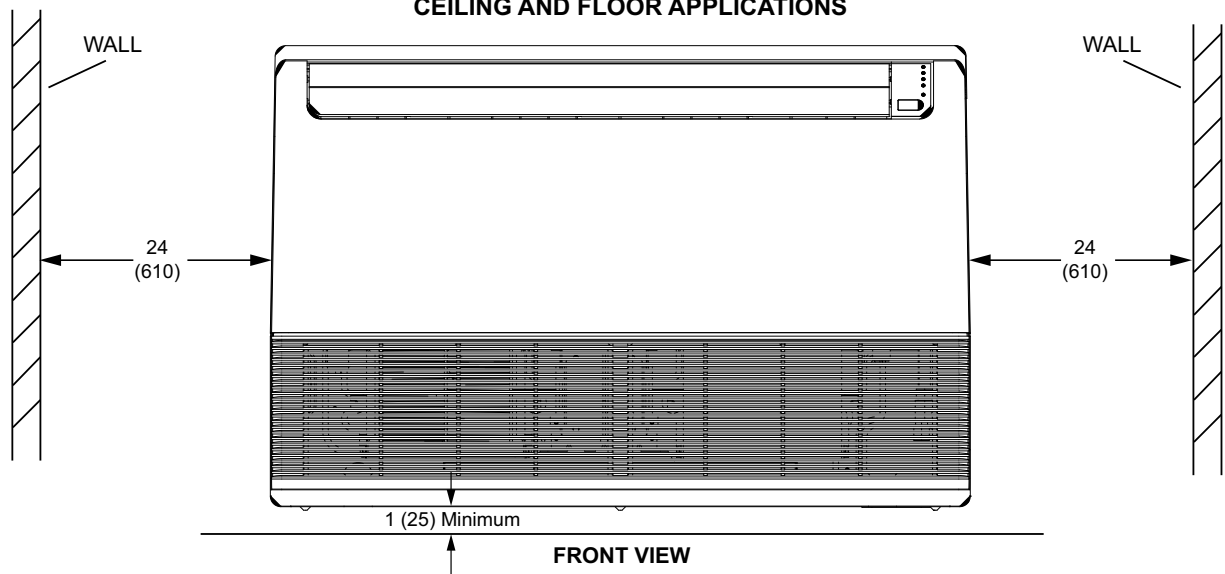

FLOOR APPLICATIONS

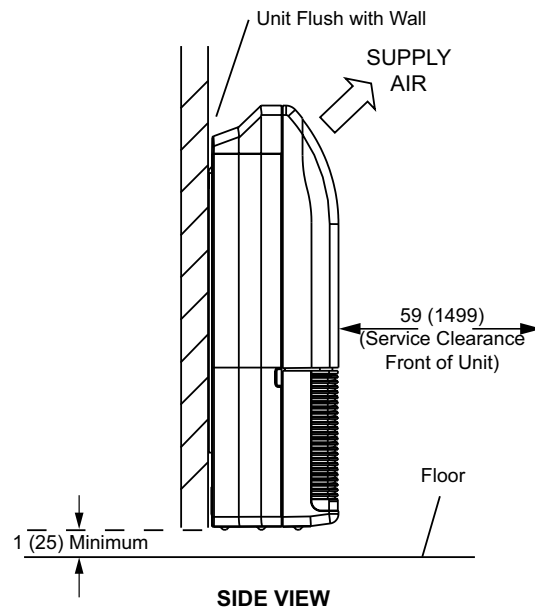

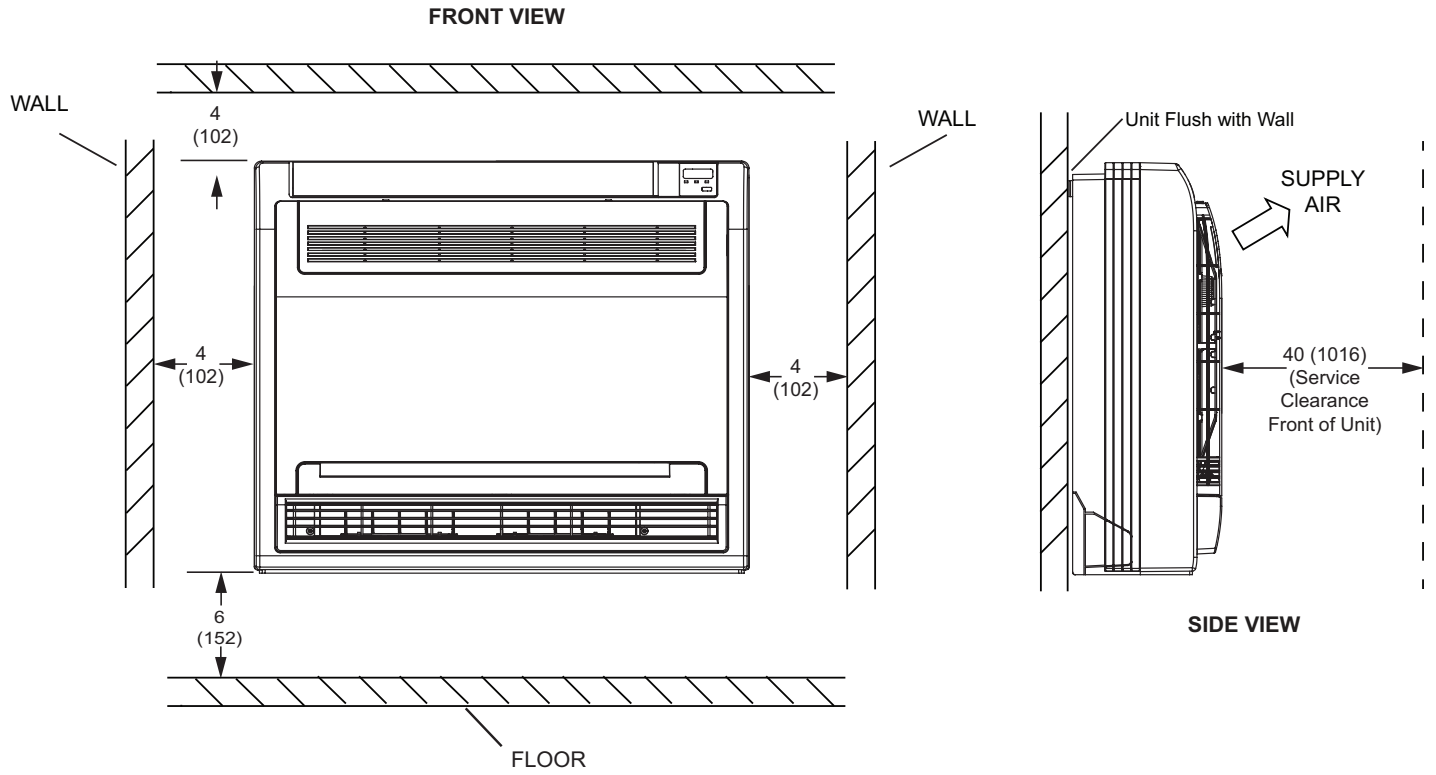

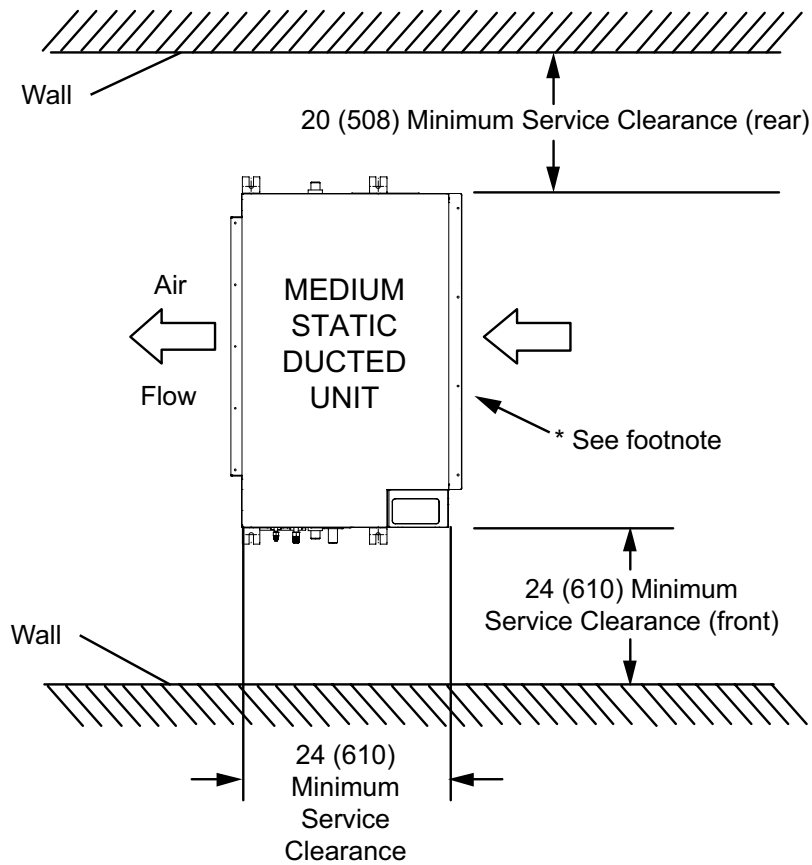

TOP VIEW

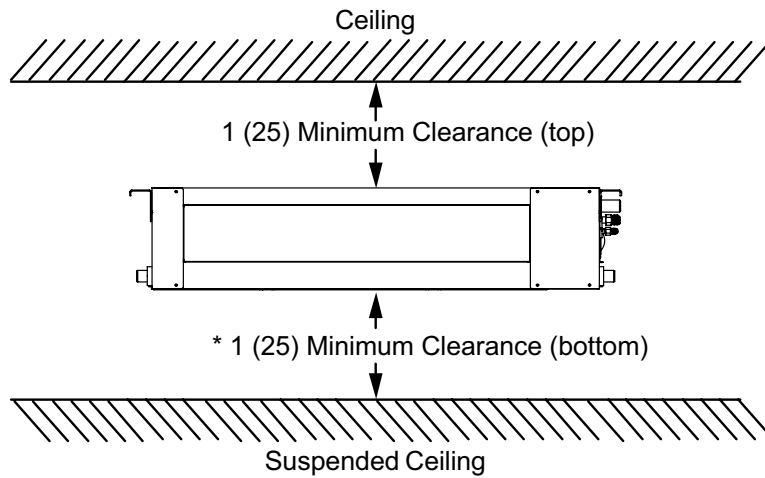

*** NOTE - Bottom unit clearance can be 1 inch (25 mm), but allow 12 inches for filter removal on end return air applications**

FRONT VIEW

LINE SET AND ELEVATION GUIDELINES

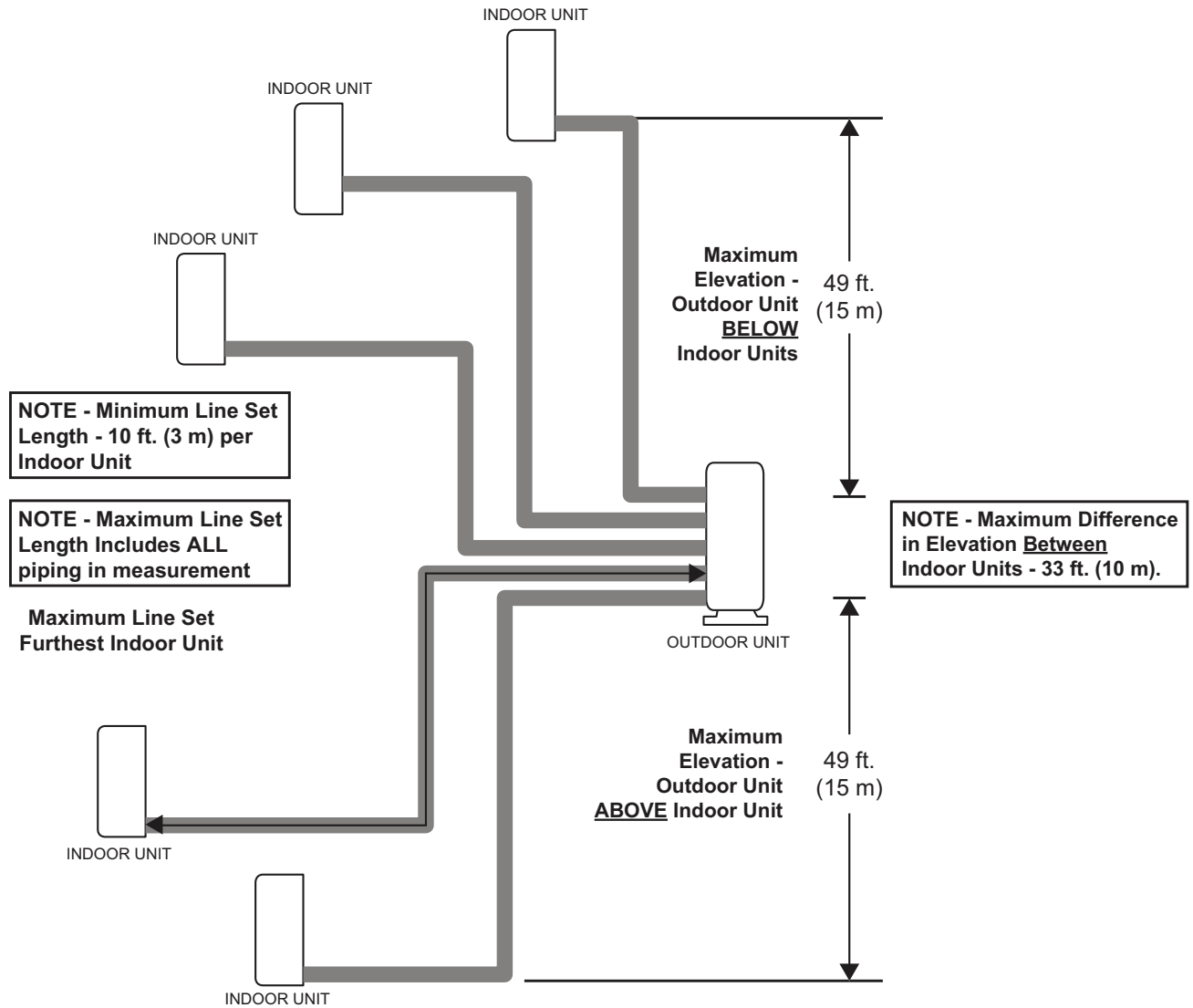

Outdoor Unit Model No.	MPB018S4M	MPB030S4M	MPB036S4M	MPB048S4M
Maximum Number of Indoor Units/Zones	Two	Three	Four	Five
Indoor Unit Connections	(2) 1/4 liq. (2) 3/8 gas	(3) 1/4 liq. (3) 3/8 gas	(4) 1/4 liq. (3) 3/8 gas (1) 1/2 gas	(5) 1/4 liq. (3) 3/8 gas (2) 1/2 gas
Maximum Pipe Length for all Rooms	131 ft. (40 m)	197 ft. (60 m)	262 ft. (80 m)	262 ft. (80 m)
Maximum Line Set Length - Furthest Indoor Unit	82 ft. (25 m)	98 ft. (30 m)	115 ft. (35 m)	115 ft. (35 m)

NOTE - Refer to "Connections And Line Set Usage" tables starting on page 26 for correct line set usage and correct refrigerant line adaptors furnished with outdoor units.

REVISIONS

Sections	Description of Change
Specifications	New MFMA012S4 Floor Mount Console model added.



HRAI
✓ MEMBER COMPANY



Intertek



Visit us at www.Lennox.com

For the latest technical information, www.LennoxPros.com

Contact us at 1-800-4-LENNOX

NOTE - Due to Lennox' ongoing commitment to quality, Specifications, Ratings and Dimensions subject to change without notice and without incurring liability. Improper installation, adjustment, alteration, service or maintenance can cause property damage or personal injury. Installation and service must be performed by a qualified installer and servicing agency.

©2020 Lennox Industries, Inc.