

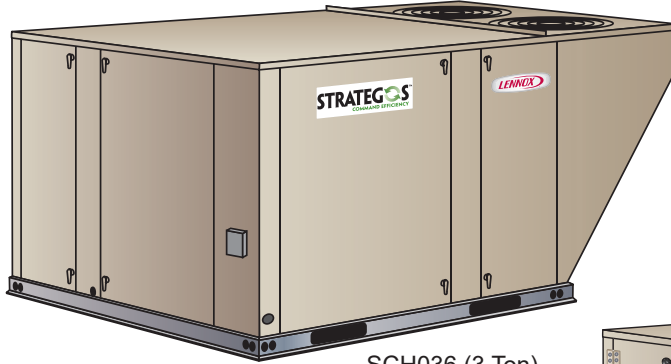

COMMERCIAL  
PRODUCT SPECIFICATIONS

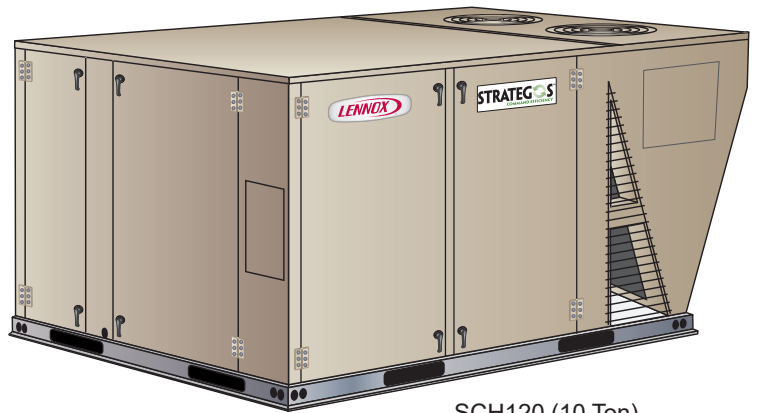

SCH036 (3 Ton)  
SCH060 (5 Ton)



SCH120 (10 Ton)

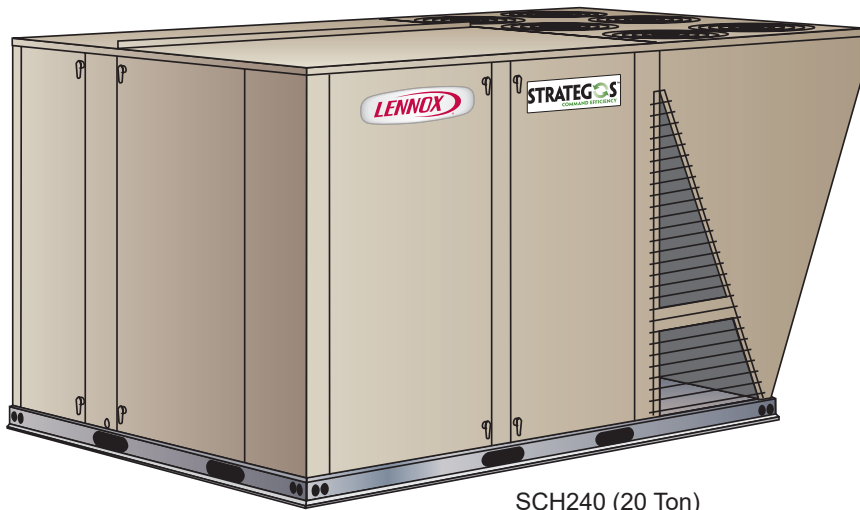

SCH240 (20 Ton)



3 to 20 Tons  
Net Cooling Capacity - 36,000 to 232,000 Btuh  
Optional Electric Heat - 10 to 90 kW

## MODEL NUMBER IDENTIFICATION

**S C H 060 H 4 E N 1 Y**

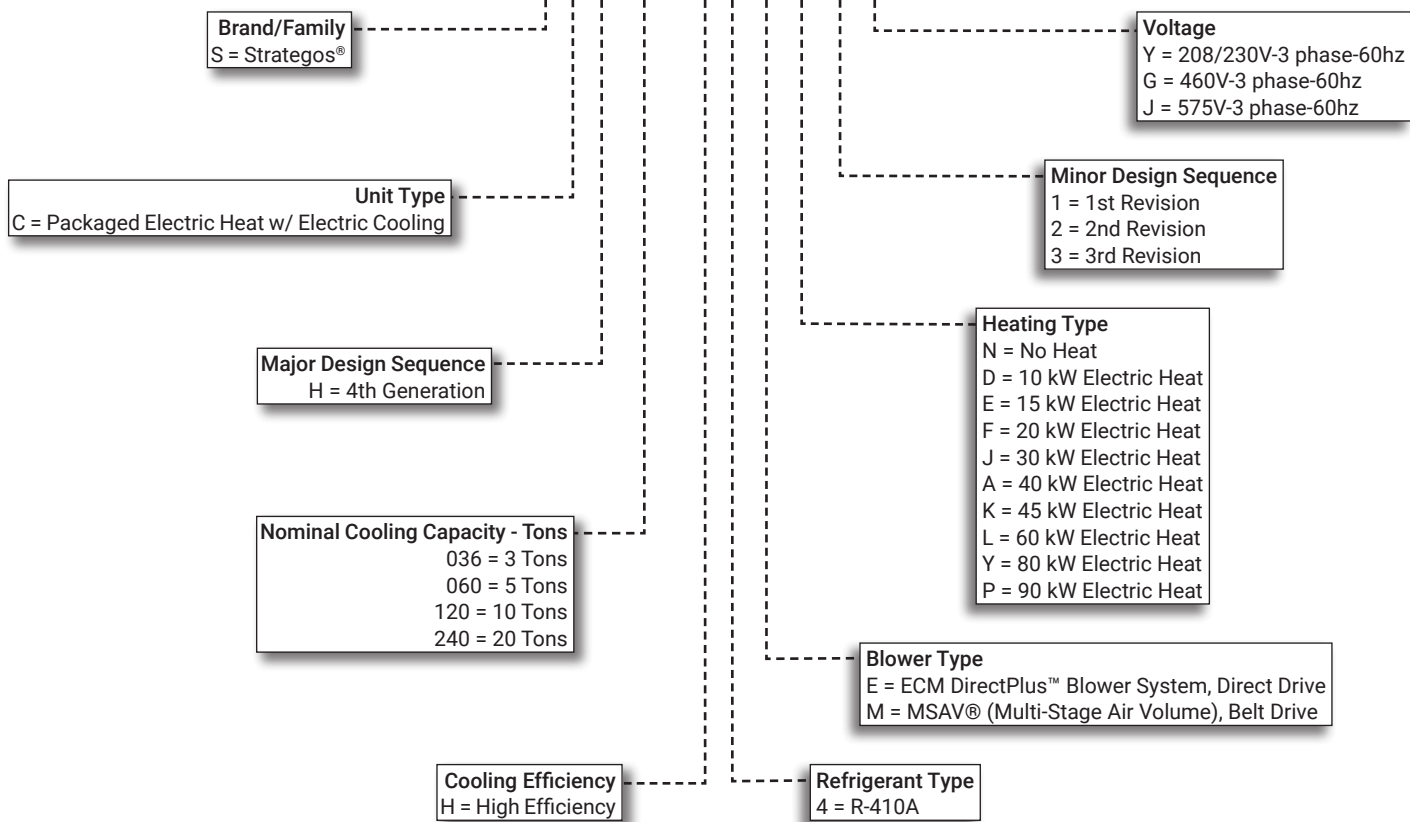

## CONTENTS

Approvals and Warranty . . . . .	4
Blower Data . . . . .	32
Control System . . . . .	8
Dimensions - Accessories . . . . .	44
Dimensions - Unit . . . . .	41
Electrical Data . . . . .	36
Features And Benefits . . . . .	4
Humiditrol® Dehumidification System Option . . . . .	11
Humiditrol® Dehumidification System Ratings . . . . .	30
Model Number Identification . . . . .	2
Options / Accessories . . . . .	22
Outdoor Sound Data . . . . .	39
Ratings . . . . .	27
Sequence Of Operation . . . . .	14
Specifications . . . . .	24
Unit Clearances . . . . .	39
Weight Data . . . . .	40

## FEATURE HIGHLIGHTS

Lennox' Strategos® packaged rooftop unit product line was created to save energy with intelligence by offering some of the highest energy efficiency ratings available with a powerful, easy to use unit controller. This makes Strategos® rooftop units perfect for business owners looking for an HVAC product with the lowest total cost of ownership

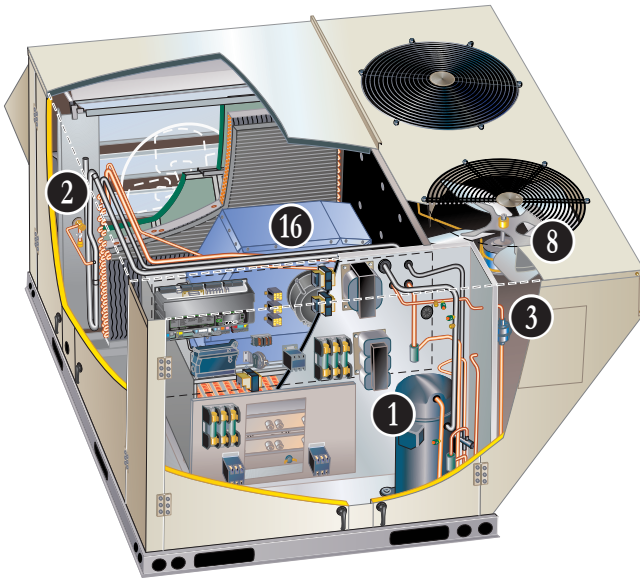

SCH036 (3 Ton)  
SCH060 (5 Ton)

1. Scroll Compressor
2. Thermal Expansion Valve
3. Filter/Drier
4. High Pressure Switch
5. Low Pressure Switch
6. Lennox' Environ™ Coil System
7. Evaporator Coil
8. Variable Speed ECM Outdoor Coil Fan Motors (3-5 Ton)

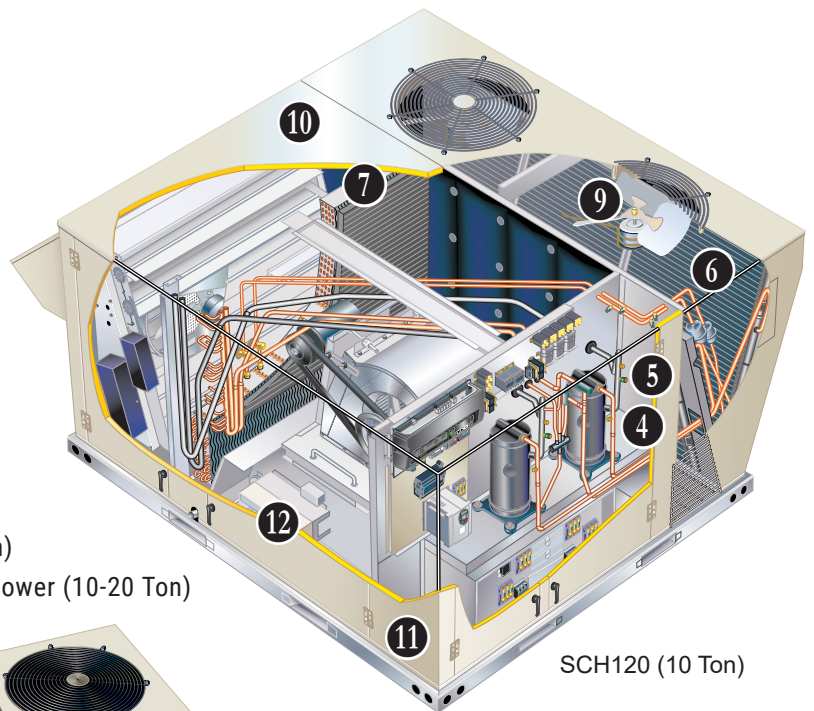

SCH120 (10 Ton)

9. Outdoor Coil Fan Motors (10-20 Ton)
10. Heavy Gauge Steel Cabinet Panels
11. Power Entry
12. Fully Insulated
13. Hinged Access Panels
14. Access panel
15. Grill Guards
16. DirectPlus™ Direct Drive ECM Blower (3-5 Ton)
17. MSAV® (Multi-Stage Air Volume) Belt Drive Blower (10-20 Ton)

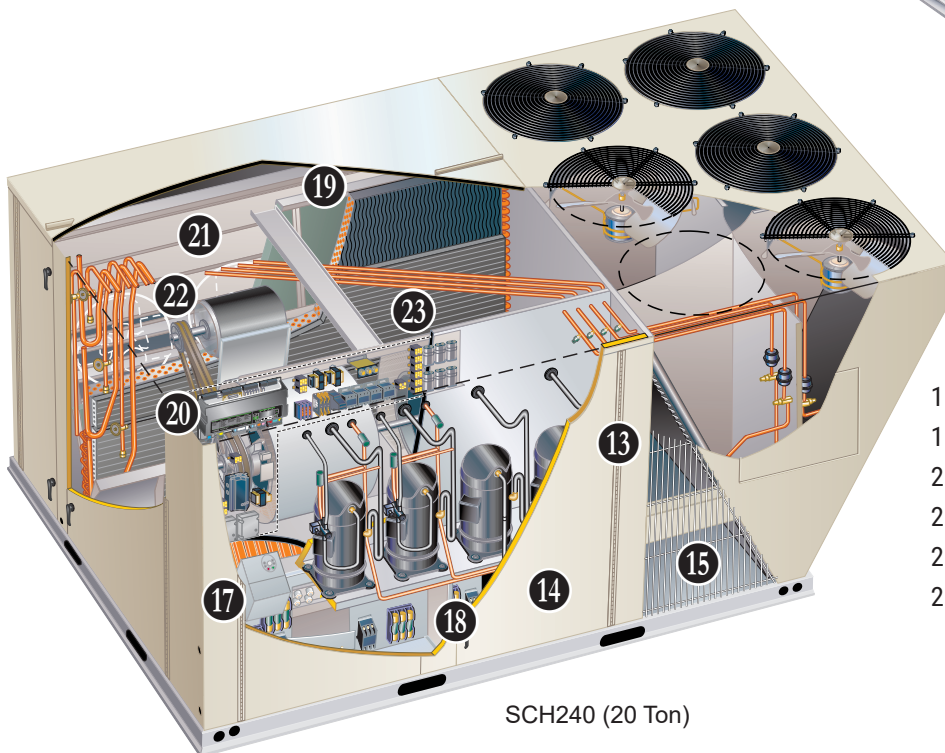

SCH240 (20 Ton)

18. Electric Heat (option)
19. Air Filters
20. Prodigy® 2.0 Unit Controller
21. Economizer (option)
22. Power Exhaust Fans (option)
23. Humiditrol® Dehumidification (option)

## APPROVALS AND WARRANTY

### APPROVALS

- AHRI Standard 210/240 certified (3 and 5 ton models)
- AHRI Standard 340/360 certified (10 and 20 ton models)
- ETL and CSA listed
- Unit and components ETL, NEC and CEC bonded for grounding to meet safety standards for servicing
- ENERGY STAR® certified

### WARRANTY

- Compressors - Limited five years
- Lennox' Environ™ Coil System - Limited three years
- Prodigy® 2.0 Unit Controller - Limited three years
- Optional High Performance Economizers - Limited five years
- All other covered components - Limited one year

## FEATURES AND BENEFITS

### COOLING SYSTEM

- Designed to maximize sensible and latent cooling performance at design conditions
- System operation from 0°F to 125°F without additional controls

#### 1 Scroll Compressors

- Two-stage (3 to 5 ton) for increased part load efficiency
- Single speed (10 and 20 ton models)
- Resiliently mounted on rubber grommets
- Quiet operation

#### Compressor Crankcase Heater

- Protects against refrigerant migration that can occur during low ambient operation

#### 2 Thermal Expansion Valve (TXV)

- Assures optimal performance throughout the application range
- Removable element head

#### 3 Filter/Drier

- Solid core, molecular-sieve, high capacity filter/drier

#### 4 High Pressure Switch

- Protects the system from high pressure conditions
- Automatic reset

#### 5 Low Pressure Switch

- Shuts off unit if suction pressure falls below setting
- Loss of charge and freeze-up protection
- Automatic reset

#### Freezestat

- Cycles compressor off when suction line temperature falls below setpoint
- Protects evaporator coil

#### Low Ambient Pressure Switches

- Cycles condenser fan motors based on liquid line pressure
- Enables cooling operation down to 0°F outdoor air temperature

#### 6 Lennox' Environ™ Coil System

- Condenser coil features lightweight, all aluminum brazed fin construction
- Constructed of three components
  - A flat extrusion tube
  - Fins in-between the flat extrusion tube
  - Two refrigerant manifolds

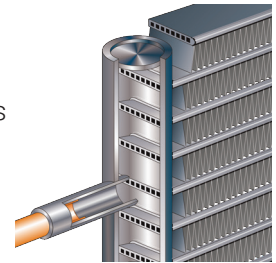

#### Environ™ Coil System Features:

- Improved heat transfer performance due to high primary surface area (flat tubes) versus secondary surface (fins)
- Smaller internal volume (reduced refrigerant charge)
- High durability
- All aluminum construction
- Fewer brazed joints
- Compact design
- Reduced unit weight
- Easy maintenance/cleaning
- Face split design
- Mounting brackets with rubber inserts
- Angled cabinet design protects coil from damage

#### 7 Evaporator Coil

- Copper tube construction
- Enhanced rippled-edge aluminum fins
- Flared shoulder tubing connections
- Silver soldered construction for improved heat transfer
- Factory leak tested
- Row split coils on multi-stage air volume models
- Cross row circuiting with rifled copper tubing optimizes both sensible and latent cooling capacity

#### Condensate Drain Pan

- Plastic pan, sloped to meet drainage requirements of ASHRAE 62.1
- Drain connection extends outside unit



## FEATURES AND BENEFITS

### **COOLING SYSTEM (continued)**

#### **8** Variable-Speed ECM Outdoor Coil Fan Motors (036-060 Only)

- Fan speed is controlled by the Prodigy® 2.0 unit controller
- Thermal overload protected
- Totally enclosed
- Permanently lubricated ball bearings
- Shaft up
- Wire basket mount

#### **9** Outdoor Coil Fan Motors (120/240 Only)

- Permanent split capacitor
- Thermal overload protected
- Totally enclosed
- Permanently lubricated ball bearings
- Shaft up
- Wire basket mount

#### **Outdoor Coil Fan**

- PVC coated fan guard

#### **R-410A Refrigerant**

- Non-chlorine
- Ozone friendly
- Unit is factory pre-charged

#### **Required Selections**

#### **Cooling Capacity**

- Specify nominal cooling capacity of the unit

#### **Options/Accessories**

#### **Factory Installed**

#### **Condensate Drain Trap**

(EPDM all sizes, Copper 240 only)

- EPDM high density rubber material

#### **Factory or Field Installed**

#### **Drain Pan Overflow Switch**

- Monitors condensate level in drain pan
- Shuts down unit if drain becomes clogged

#### **CABINET**

#### **10** Construction

- Heavy-gauge steel panels
- Full perimeter heavy-gauge galvanized steel base rail (provides structural integrity for transportation, handling, and installation)
- Base rails have rigging holes
- Fork slots (two sides on the 3 and 5 ton models, three sides on the 10 and 20 ton models)
- Raised edges around duct and power entry openings in the bottom of the unit for water protection

#### **Airflow**

- Units are shipped in downflow (vertical) configuration

#### **11** Power Entry

- Electrical lines can be brought through the unit base or through horizontal access knock-outs

#### **12** Exterior Panels

- Constructed of heavy-gauge, galvanized steel
- Two-layer enamel paint finish

#### **13** Insulation

- Fully insulated with non-hygroscopic fiberglass insulation (conditioned areas)
- Unit base is fully insulated
- Base insulation serves as an air seal to the roof curb, eliminating the need to add a seal during installation

#### **14** Hinged Access Panels

- Economizer/filter section
- Blower section
- Compressor/controls/heat section
- Hinges are constructed of galvanized-steel
- Panel seals and quarter-turn latching handles provide a tight air and water seal

#### **15** Grille Guards

- Protects space between outdoor coils and main cabinet

#### **Options/Accessories**

#### **Factory Installed**

#### **Corrosion Protection**

- Completely flexible immersed coating
- Electrodeposited dry film process
- AST ElectroFin E-Coat
- Meets Mil Spec MIL-P-53084, ASTM B117 Standard Method Salt Spray Testing

#### **Option 1:**

- Coated indoor and outdoor coil assemblies (including tube sheets)
- Painted cabinet interior

#### **Option 2:**

- Coated outdoor coil assembly (including tube sheets)

#### **Factory or Field Installed**

#### **Combination Coil/Hail Guards**

- Heavy gauge steel frame
- Painted to match cabinet
- Expanded metal mesh protects outdoor coil

## FEATURES AND BENEFITS

### **BLOWER**

#### **16 DirectPlus™ Direct Drive ECM Blower System (036-060 Models Only)**

- High-efficiency, variable-speed ECM (electronically commutated) motor
- Aerodynamically optimized impeller
- Backward curved blades mounted directly onto the rotor
- Combines the motor and electronics into one unit
- Eliminates the need for a variable-frequency drive
- Ramps the blower up or down to meet comfort needs
- Blower assembly slides out of unit for servicing



- Air inlet grill reduces indoor sound levels without affecting air performance

#### **17 MSAV® (Multi-Stage Air Volume) Belt Drive Blower System (120-240 Models Only)**

- Supply air variable frequency drive (VFD)
- Stages the amount of supply blower airflow according to compressor stages, heating demand, ventilation demand or smoke alarm
- Alters frequency and voltage of the power supply to the blower to control speed
- The amount of airflow for each stage can be set according to a parameter in the Prodigy 2.0 unit controller
- Unit is shipped from the factory with preset airflow
- The VFD has an operational range of 0 to 125°F outdoor air ambient temperature
- Lower operating costs are obtained when the blower is operated on lower speeds
- Overload protected
- Equipped with ball bearings
- All blower motors 5 hp and above meet minimum energy efficiency standards in accordance with the Energy Independence and Security Act (EISA) of 2007
- Forward curved blades
- Double inlet
- Blower wheel is statically and dynamically balanced
- Equipped with ball bearings
- Adjustable pulley (allows speed change during commissioning).
- Blower assembly slides out of unit for servicing

#### **Blower Proving Switch**

- Monitors blower operation, shuts down unit if blower fails

### **Required Selections**

#### **Blower Motor Choice (240 only)**

- Specify when ordering base unit

#### **Electronic Bypass Control (120-240 Models Only)**

- Manual (default) or automatic electronic bypass VFD control
- In case of VFD malfunction, a VFD alarm is generated by the Prodigy® 2.0 unit controller
- VFD can be manually bypassed to continue unit operation at full blower speed. Or the unit controller can be set to automatically switch to full blower speed if a VFD alarm is generated

## FEATURES AND BENEFITS

### ELECTRICAL

#### SmartWire™ System

- Advanced wiring connectors
- Keyed and color-coded to prevent miswiring
- Wire coloring scheme is standardized across all models
- Each connection is intuitively labeled to make troubleshooting and servicing quick and easy

#### Circuit Breakers

- HACR type
- For overload and short circuit protection
- Factory wired
- Current sensitive and temperature activated
- Manual reset
- Mounted in the power entry panel

#### Electrical Plugs

- Positive connection electrical plugs connect common accessories and maintenance parts for easy removal or installation

#### Required Selections

#### Voltage Choice

- Specify when ordering base unit

#### Options/Accessories

#### Factory Installed

#### Short-Circuit Current Rating (SCCR) (240 models only)

- Higher short circuit protection up to 100kA

#### Factory or Field Installed

#### 18 Electric Heat

- Helix wound nichrome elements
- Time delay for element staging
- Individual element limit controls
- Wiring harness
- May be four-stage controlled in zone sensor mode
- All required components are included

#### GFI Service Outlets (2)

- 115V ground fault circuit interrupter (GFCI) type
- Non-powered
- Field-wired (all models)
- Factory-wired and powered (240 model only)

#### Field Installed

#### GFI Weatherproof Cover

- Single-gang cover
- Heavy-duty UV-resistant polycarbonate case construction
- Hinged base cover with gasket

### INDOOR AIR QUALITY

#### 19 Air Filters

- MERV 8 (Minimum Efficiency Reporting Value) based on ASHRAE 52.2 efficiency
- Disposable
- 2 inch pleated

#### Options/Accessories

#### Field Installed

#### Healthy Climate® MERV 13 High Efficiency Air Filters

- MERV 13 (Minimum Efficiency Reporting Value) based on ASHRAE 52.2 efficiency
- Disposable
- 2 inch pleated

#### Indoor Air Quality (CO<sub>2</sub>) Sensor

- Monitors CO<sub>2</sub> levels and reports to unit controller which adjusts economizer dampers as needed
- MSAV (multi-stage air volume) units with an economizer require a CO<sub>2</sub> sensor to modulate the economizer damper and maintain the desired minimum amount of fresh outdoor air
- CO<sub>2</sub> sensor can be installed in either the occupied zone or the return air duct

#### Replacement Filter Media Kit With Frame (240 Only)

- Replaces existing pleated filter media
- Includes washable metal mesh screen and metal frame
- Clip holds replaceable non-pleated filter

## CONTROL SYSTEM

### 20 **PRODIGY® CONTROL SYSTEM**



The Prodigy 2.0 unit controller is a microprocessor-based controller that provides flexible control of all unit functions.

#### Features:

- LCD Display
- Easy to read menu (4 lines x 20 character display)
- Buttons for menu navigation during setup and diagnostic
- Menu navigation LEDs for Data, Setup, Service, Settings
- Main Menu and Help Buttons for quick navigation to home screen and built-in help functions
- Scroll, Value Adjustment Select and Save Buttons
- Setup menu insures proper installation and simplified setup of the rooftop unit
- Profile setup copies key settings between units with the same configuration to reduce setup time
- USB port allows a technician to download and transfer unit information to help verify service was performed
- USB software updates on the Prodigy Control System enhance functionality without the need to change components
- Unit Controller Software
- Unit self-test verifies individual critical component and system performance
- Economizer test function assures economizer is operating correctly
- Time Clock with Run-Time Information

#### Built-In Functions Include:

- Adjustable Blower On/Off Delay
- Built-in Control Parameter Defaults
- Compressor Time-Off Delay
- DDC Compatible
- Dirty Filter Switch Input
- Discharge Air Temperature Control
- Display/Sensor Readout
- Economizer Control Options (See Economizer / Exhaust Air / Outdoor Air sections)
- Fresh Air Tempering
- Over 100 diagnostic and status messages in English
- Exhaust Fan Control Modes for fresh air damper position (differential pressure transducer or pressure switches)
- Permanent Diagnostic Code Storage
- Field Adjustable Control Parameters (Over 200 settings)
- Indoor Air Quality Input (Demand Control Ventilation)
- Low Ambient Controls for cooling operation down to 0°F

- Gas Valve Time Delay Between First and Second Stage
- Minimum Compressor Run Time
- Network Capable (Can be daisy chained to other units or controls)
- Night Setback Mode
- Return Air Temperature Limit Control
- Safety Switch Input allows Controller to respond to a external safety switch trip
- Service Relay Output
- Smoke Alarm Mode has four choices (unit off, positive pressure, negative pressure, purge)
- Up to 2 heat/2 cool (standard Prodigy unit controller thermostat input)
- Up to 3 cool with additional relay
- Up to 4 cool with room sensor or network operation
- "Strike Three" Protection
- Gas Reheat Control allows simultaneous heating and cooling operation for humidity control of process air applications such as supermarkets
- On Demand Dehumidification monitors and controls condenser hot gas reheat operation with Humiditrol® dehumidification option
- Thermostat Bounce Delay
- Warm Up Mode Delay
- LED Indicators
- PC Interface connects the Prodigy 2.0 unit controller to a PC with the Lennox Unit Controller Software
- Room Sensor Operation controls temperature

**NOTE** - Prodigy Control System features vary with the type of rooftop unit in which the control is installed.

**NOTE** - See separate Prodigy Control System Product Specifications Bulletin for additional information.

## CONTROL SYSTEM

### **PRODIGY® CONTROL SYSTEM (continued)**

#### Control Options

##### **Factory Installed**

###### **Blower Proving Switch**

- Monitors blower operation, shuts down unit if blower fails

##### **Factory or Field Installed**

###### **Dirty Filter Switch**

- Senses static pressure increase indicating dirty filter condition

###### **Fresh Air Tempering**

- Used in applications with high outside air requirements
- Controller energizes the first stage heat as needed to maintain a minimum supply air temperature for comfort, regardless of the thermostat demand
- When ordered as a factory option, sensor ships with the unit for field installation

###### **Smoke Detector**

- Photoelectric type
- Installed in supply air section, return air section or both sections
- Available with power board and single sensor (supply or return) or power board and two sensors (supply and return)
- Power board located in unit control compartment

###### **Interoperability via BACnet® or LonTalk® Protocols**

- Communication compatible with third-party automation systems that support the BACnet Application Specific Controller device profile, LonMark® Space Comfort Controller functional profile, or LonMark Discharge Air Controller functional profile

##### **Commercial Control Systems**

###### **L Connection® Network Control System**

- Complete building automation control system for single or multi-zone applications
- Options include local interface, software for local or remote communication, and hardware for networking other control functions
- See L Connection Network Control System Product Specifications Bulletin for details

###### **After-Market DDC**

- Novar® Unit Controller and options

###### **Thermostats**

- Control system and thermostat options
- After-Market unit controller options

##### **Field Installed**

###### **General Purpose Control Kit**

- Plug-in control provides additional analog and digital inputs/outputs for field installed options

## OPTIONS / ACCESSORIES

### **21 ECONOMIZER**

##### **Factory or Field Installed**

- Economizer operation is set and controlled by the Prodigy® 2.0 Unit Controller
- Simple plug-in connections from economizer to unit controller
- All Strategos rooftop units are equipped with factory installed CEC Title 24 approved sensors for outside, return and discharge air temperature monitoring

**NOTE** - Optional sensors may be used instead of unit sensors to determine whether outdoor air is suitable for free cooling. See Options/Accessories table.

##### **High Performance Economizer Features**

- Outdoor air hood is furnished
- Approved for California Title 24 building standards.
- Low leakage dampers are Air Movement and Control Association International (AMCA) Class 1A Certified - Maximum 3 CFM per sq. ft. leakage at 1 in. w.g.
- ASHRAE 90.1-2010 compliant
- Gear-driven action
- High torque 24-volt fully-modulating spring return damper motor
- Return air and outdoor air dampers
- Plug-in connections to unit
- Nylon bearings (036-060)
- Stainless steel bearings (120-240)
- Enhanced neoprene blade edge seals
- Flexible stainless steel jamb seals minimize air leakage.

**NOTE** - High Performance Economizers are not approved for use with enthalpy controls in Title 24 applications.

**NOTE** - The Free Cooling setpoint for Title 24 applications must be set based on the Climate Zone where the system is installed. See Section 140.4 "Prescriptive Requirements for Space Conditioning Systems" of the California Energy Commission's 2013 Building Energy Efficiency Standards.

**NOTE** - Refer to Installation Instructions for complete setup information.



## OPTIONS / ACCESSORIES

### ECONOMIZER (continued)

#### Options / Accessories

#### Field Installed

##### **Global Control (Not for Title 24)**

- The unit controller communicates with a DDC system with one global sensor (enthalpy or sensible)
- Determines whether outside air is suitable for free cooling on all units connected to the control system
- Sensor must be field provided

##### **Single Enthalpy Temperature Control (Not for Title 24)**

- Outdoor air enthalpy sensor enables Economizer if the outdoor enthalpy is less than the setpoint of the control.

##### **Differential Enthalpy Control (Not for Title 24)**

- Order two Single Enthalpy Controls
- One is field installed in the return air section
- One is installed in the outdoor air section
- Allows the economizer control to select between outdoor air or return air, whichever has lower enthalpy

### EXHAUST AIR

#### Factory Installed

#### **22 Power Exhaust Fan(s) (120 and 240 Models Only)**

- Installs external on 10 ton model with economizer option
- Installs internal to 20 ton models with economizer option
- Provides exhaust air pressure relief
- Interlocked to run when supply air blower is operating
- Fan runs when outdoor air dampers are 50% open (adjustable)
- Fan motor is overload protected
- 10-ton model includes steel cabinet and hood painted to match unit

##### **120 Model**

- One, 1/2 hp motor
- Five fan blades
- Total power input - 300 Watts
- Total air volume of 4085 cfm at 0.05 in. w.g.

##### **240 Model**

- Three, 1/3 hp motors
- 20 in. diameter, five fan blades
- Total power input - 1200 Watts
- Total air volume of 10,200 cfm at 0 in. w.g.

#### Factory or Field Installed

##### **Barometric Relief Dampers**

- Allows relief of excess air
- Dampers prevent blow back and outdoor air infiltration during off cycle
- Outdoor air hood is furnished with field installed barometric relief dampers for 120-240 models with Power Exhaust
- See Options/Accessories table

### OUTDOOR AIR

#### Factory Installed

##### **Manual Outdoor Air Damper (240 Models Only)**

- 0 to 25% (fixed) outdoor air adjustable slide damper
- Installed in unit
- Outdoor air hood with bird screen included.

##### **Motorized Outdoor Air Dampers (240 Models Only)**

- Linked dampers with a fully modulating spring return damper motor
- Installed in unit
- Outdoor air hood with bird screen included.

### ROOF CURBS

#### Factory Installed

##### **Curb Alignment (240 Models Only)**

- Adapter plate mates new unit to existing roof curb for easy replacement of older LCE240 models

#### Field Installed

##### **Hybrid Roof Curbs, Downflow**

- Interlocking tabs fasten corners together
- No tools required
- Can also be fastened together with furnished hardware
- Available in 14 and 24 inch heights
- See Options/Accessories table

### 23 OVERVIEW

- Factory installed option designed to control humidity
- Provides dehumidification on demand using ASHRAE 90.1 recommended method for comfort conditioning humidity control
- Unit comes equipped with one row reheat coil, solenoid valve and humidity controller
- In addition to a thermostat or room sensor used for conventional operation, a humidity sensor is required and must be located in the occupied space
- Remote Mounted Humidity Sensor Kit is required for field installation
- Humidity sensor provides input to the Unit Controller which is used to control activation of the dehumidification operation
- Reheat controls are located in the compressor control section of the unit for easy access

### **BENEFITS**

- Improves indoor air quality
- Helps prevent damage due to high humidity levels
- Improves comfort levels by reducing space humidity levels

### **OPERATION**

#### **No Dehumidification Demand**

- The unit will operate conventionally whenever there is a demand for cooling or heating and no dehumidification demand
- Free cooling is only permitted when there is no demand for dehumidification

#### **Dehumidification Demand Only**

- The Unit Controller is factory set at 60% relative humidity setpoint and can be adjusted at the Unit Controller or with optional Unit Controller Software
- For L Connection® Network Control Panel (NCP) applications, the humidity setpoint can be adjusted at the NCP
- Reheat operation will initiate on a dehumidification demand and does not require a cooling demand
- The unit will operate in the dehumidification mode until the relative humidity of the conditioned space is below the setpoint
- The reheat coil is sized to provide 68°F to 75°F supply air during reheat operation
- This reduces sensible cooling capacity and extends compressor run time to control humidity when the cooling load is low
- A solenoid valve diverts hot gas from the compressor to the reheat coil
- The cooled and dehumidified air from the evaporator is reheated as it passes through the reheat coil
- The de-superheated and partially condensed refrigerant continues to the outdoor condenser coil where condensing is completed
- The unit will continue to operate in this mode until the dehumidification demand is satisfied

**NOTE** - See Sequence of Operation for additional information.

#### **Dehumidification and Cooling Demand (Thermostat/ Room Sensor Application)**

##### **Two-stage compressor models (036 and 060)**

- If both a dehumidification and a Y1 cooling demand occur, the system will operate in the full cooling mode at first stage indoor air flow
- If a Y2 cooling demand occurs along with a dehumidification demand, the system operates in full cooling mode at full cooling airflow until the Y2 cooling demand is satisfied
- Then the system will revert to the dehumidification mode if a dehumidification mode demand is present

##### **Single Speed Compressor Model (120/240)**

- If both a dehumidification and a full cooling demand occur, the system will operate in cooling until the cooling demand is satisfied
- Then the system will energize the dehumidification mode

### **Options/Accessories**

#### **Humidity Sensor Kit**

- Remote Mounted Humidity sensor required with factory installed Humiditrol® Dehumidification Option or Supermarket reheat field selectable option

REFRIGERANT SCHEMATIC - 036H-60H MODELS

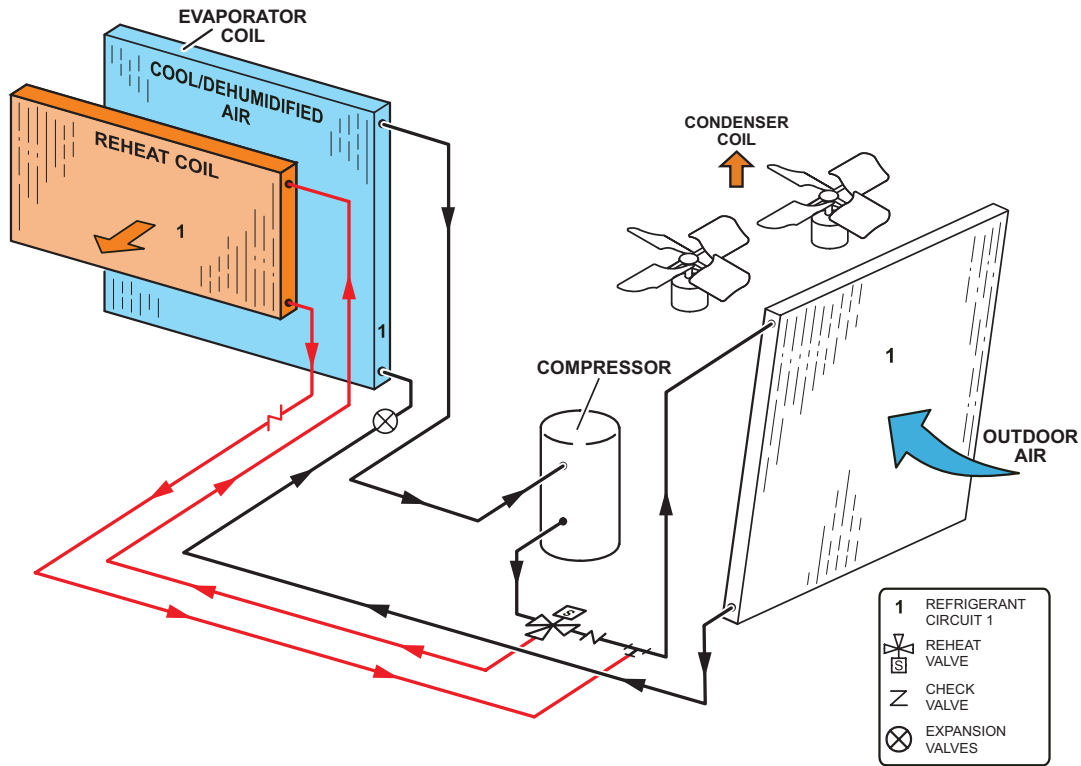

REFRIGERANT SCHEMATIC - 120H MODEL

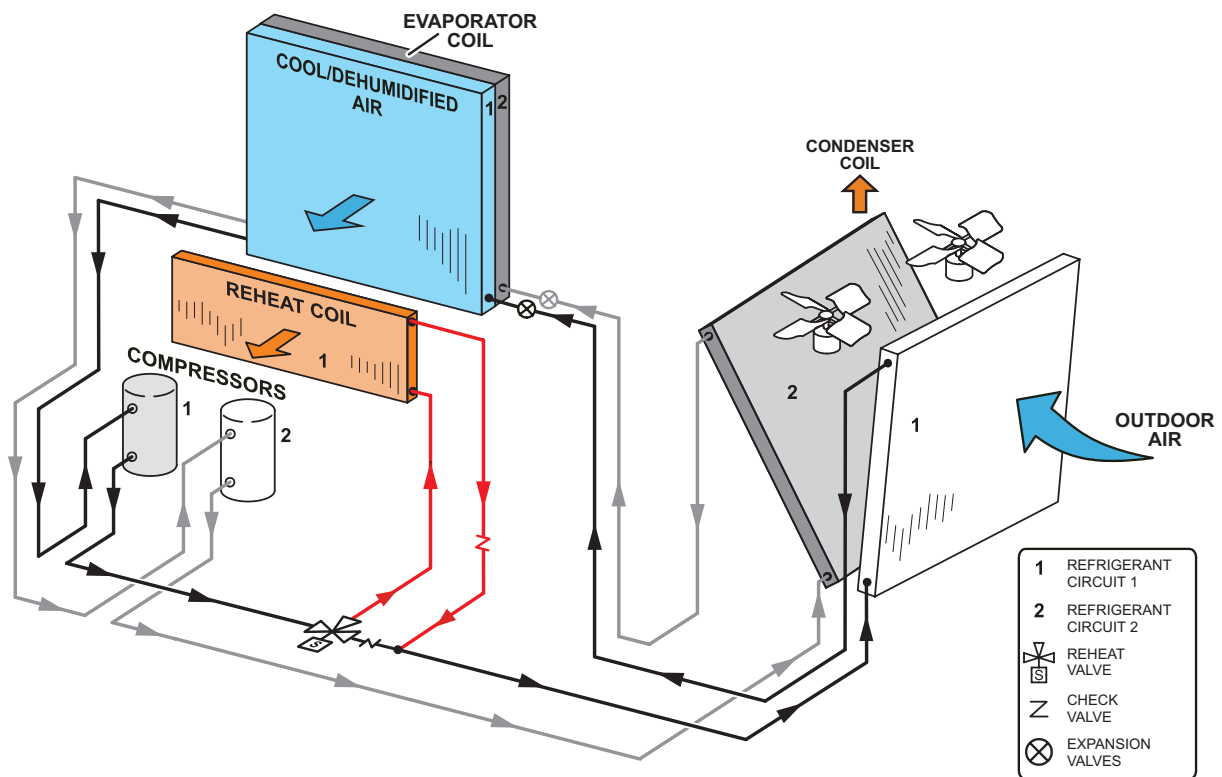

# HUMIDITROL® DEHUMIDIFICATION SYSTEM

## REFRIGERANT SCHEMATIC - 240H MODEL

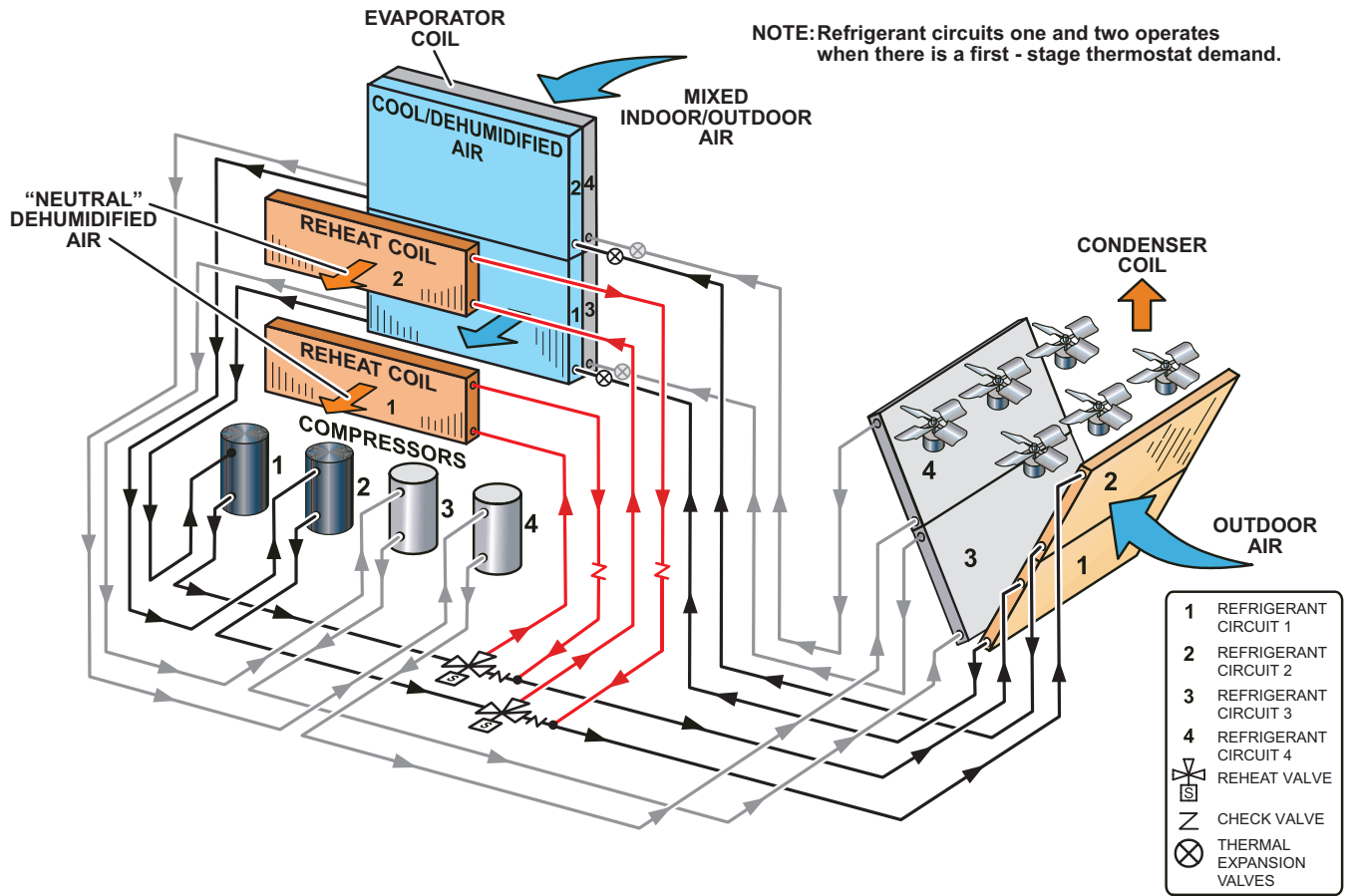

**Objective:** Outline the unit functions as a result of room thermostat or zone sensor demands.

**Given:** When economizer is present, it will function as initial part of the unit cooling system. When not present, unit will function as if outdoor ambient is high and sensed as not suitable.

**DIRECT DRIVE SYSTEM OPERATION (3 AND 5 TONS MODELS):**

*Note: DirectPlus™ direct drive units feature ECM condenser fans that are staged to match the compressor's capacity. When the compressor is operating at first stage, the condenser fan is operating at low speed. The condenser fan switches to high speed when the compressor switches to second stage to match operation.*

**Modulating Outdoor Air Damper:**

*Damper minimum positions #1 and 2 are adjusted during unit setup to provide minimum fresh air requirements at the indicated supply air blower speeds per ASHRAE 62.1.*

- Supply air blower is off and the outdoor air damper is closed
- Supply air blower is on low speed and the outdoor air damper is at minimum position 1
- Supply air blower is on high speed and the outdoor air damper is at minimum position 2

**<sup>1</sup> Unit Features an Economizer and Outdoor Air is Suitable**

Cooling - Thermostat (Up to 2 stages Y1, Y2) or Zone Sensor Mode (Up to 3 stages Y1, Y2, Y3)

**Y1 Demand:**

- 1st: Compressor is off, supply air blower is on low speed, economizer modulates (minimum to maximum open position) to maintain 55°F supply air temperature (default unit controller setting)
- 2nd: After 5 minutes (default unit controller setting), supply air blower switches to high speed. Economizer continues modulating with supply air blower on high speed to maintain 55°F supply air temperature

**Y2 Demand:**

- 1st: Compressor is off, supply fan is on high speed, and economizer modulates to maintain 55°F supply air temperature
- 2nd: Economizer opens to maximum. If economizer stays at maximum open for 3 minutes (default unit controller setting) compressor is energized and operates at first stage while supply fan stays on high speed

<sup>1</sup> *Outdoor air suitability is determined by the energy state of outdoor ambient (enthalpy or sensible) and its ability to achieve the desired free cooling effects. Outdoor air suitability can also be determined by a third party controller and provided to the RTU via a network connection.*

**Y3 Demand:**

- 1st: Economizer is at maximum open and compressor operates at first stage. If economizer stays at maximum open for 3 minutes (default unit controller setting) compressor switches to second stage operation while supply fan stays on high speed

**Unit Does Not Feature An Economizer Or Outdoor Air Is Not Suitable**

Cooling - Thermostat or Zone Sensor (Up to 2 stages Y1, Y2)

**Y1 Demand:**

- 1st: Compressor operates at first stage and supply air blower operates at low speed

**Y2 Demand:**

- 1st: Compressor operates at second stage and supply air blower operates at high speed



**DIRECT DRIVE SYSTEM OPERATION (3 AND 5 TONS MODELS) (CONTINUED):****Dehumidification Mode (economizer free cooling is locked out):**

Unit features the Humiditrol® Dehumidification option.

**No Y1, Y2 Demand but a call for dehumidification:**

1st: Compressor operates at second stage, supply air blower operates at low speed, and the reheat valve is energized

**Y1 Demand:**

1st: Compressor operates at second stage, outdoor fan operates at high speed, supply air blower operates at low speed and the reheat valve is de-energized

**Y2 Demand:**

1st: Compressor operates at second stage, supply air blower operates at high speed, and the reheat valve is de-energized

**Heating Mode (Thermostat or Zone Sensor- Electric Heat)**

*Note: Heating mode is the same for all control options*

**W1 Demand:**

1st stage electric heat is energized and the supply air blower operates at heating speed.

**W2 Demand:**

2nd stage electric heat is energized and the supply air blower operates at heating speed (20 or 30 kW electric heat option only).

**Objective:** Outline the unit functions as a result of room thermostat or zone sensor demands.

**Given:** When economizer is present, it will function as an integral part of the unit cooling system. When not present, unit will function as if economizer is present but outdoor ambient is high and sensed as not suitable.

### **UNIT OPERATION WITH 2-STAGE THERMOSTAT (2 COOL AND 2 HEAT STAGES, Y1, Y2, W1, W2)**

#### **SUPPLY AIR BLOWER SPEED**

Unit has following supply air blower speed setting:

- Ventilation Speed
- Cooling Speed - Low
- Cooling Speed - High
- Heating Speed
- Smoke Speed (Used only in smoke removal option - not discussed)

#### **<sup>1</sup> Unit Features An Economizer And Outdoor Air Is Suitable**

Cooling - Thermostat Mode (Y1, Y2)

##### **Y1 Demand:**

All compressors are off, supply air blower is on low cooling speed to minimize blower power consumption, economizer modulates (minimum to maximum open position) to maintain 55°F supply air temperature (default unit controller setting).

##### **Y2 Demand:**

All compressors are off, supply air blower is on high cooling speed providing higher cooling capacity, and economizer modulates to maintain 55°F supply air temperature.

If economizer stays at maximum open for 3 minutes, compressor 1 is energized while supply air blower stays on high cooling speed providing maximum cooling capacity.

<sup>1</sup> Outdoor air suitability is determined by the energy state of outdoor ambient (enthalpy or sensible) and its ability to achieve the desired free cooling effects. Outdoor air suitability can also be determined by a third party controller and provided to the rooftop unit via a network connection.

#### **Unit Does Not Feature An Economizer Or Outdoor Air Is Not Suitable**

##### **Y1 Demand:**

1st Compressor operates and supply air blower operates at low cooling speed.

##### **Y2 Demand:**

All compressors operate and supply air blower operates at high cooling speed.

#### **Dehumidification Mode**

If a unit with Humiditrol® Dehumidification Option receives a call for dehumidification, economizer free cooling is locked out.

##### **Call For Dehumidification, No Y1, Y2 Demand:**

1st stage compressor operates, supply air blower operates at low cooling speed, and the reheat valve is energized.

##### **Y1 Demand With A Call For Dehumidification:**

All compressors operate, supply air blower operates at high cooling speed and the reheat valve is energized.

##### **Y2 Demand With A Call For Dehumidification:**

All compressors operate, supply air blower operates at high cooling speed, and the reheat valve is de-energized.

**UNIT OPERATION WITH ZONE SENSOR (3 COOL AND 2 HEAT STAGES, Y1, Y2, Y3 AND W1, W2)****SUPPLY AIR BLOWER SPEED**

Unit has following supply air blower speed setting:

- Ventilation Speed
- Cooling Speed - Low
- Cooling Speed - High
- Heating Speed
- Smoke Speed (Used only in smoke removal option - not discussed)

**<sup>1</sup> Unit Features An Economizer And Outdoor Air Is Suitable**

Cooling - Thermostat or Zone Sensor Mode (Y1, Y2, Y3)

**Y1 Demand:**

All compressors are off, supply air blower is on low cooling speed to minimize blower power consumption, economizer modulates (minimum to maximum open position) to maintain 55°F supply air temperature (default unit controller setting).

**Y2 Demand:**

All compressors are off, supply air blower is on high cooling speed providing higher cooling capacity, and economizer modulates to maintain 55°F supply air temperature.

If economizer stays at maximum open for 3 minutes, compressor 1 is energized while supply air blower stays on high cooling speed providing maximum cooling capacity. After compressors are energized the economizer stays at maximum open.

**Y3 Demand:**

Compressors 1 and 2 are energized while supply air blower stays on high cooling speed.

<sup>1</sup> Outdoor air suitability is determined by the energy state of outdoor ambient (enthalpy or sensible) and its ability to achieve the desired free cooling effects. Outdoor air suitability can also be determined by a third party controller and provided to the rooftop unit via a network connection.

**Unit Does Not Feature An Economizer Or Outdoor Air Is Not Suitable****Y1 Demand:**

Compressor 1 operates and supply air blower operates at low cooling speed.

**Y2 or Y3 Demand:**

All compressors operate and supply air blower operates at high cooling speed.

**Dehumidification Mode**

If a unit with Humiditrol® Dehumidification Option receives a call for dehumidification, economizer free cooling is locked out.

**Call For Dehumidification, No Y1, Y2 Demand:**

1st stage compressor operates, supply air blower operates at low cooling speed, and the reheat valve is energized.

**Y1 Demand With A Call For Dehumidification:**

All compressors operate, supply air blower operates at high cooling speed and the reheat valve is energized.

**Y2 Or Y3 Demand With A Call For Dehumidification:**

All compressors operate, supply air blower operates at high cooling speed, and the reheat valve is de-energized.

**UNIT OPERATION WITH ZONE SENSOR (3 COOL AND 2 HEAT STAGES, Y1, Y2, Y3 AND W1, W2) (CONTINUED)****Heating Mode (Electric Heat)**

*NOTE - Heating mode is the same for all control options*

**W1 Demand:**

1st stage electric heat is energized and the supply air blower operates at heating speed.

**W2 Demand:**

2nd stage electric heat is energized and the supply air blower operates at heating speed (20 or 60 kW electric heat option only).

**Modulating Outdoor Air Damper**

The minimum damper position for “occupied low blower” and “occupied high blower” is adjusted during unit setup to provide minimum fresh air requirements per ASHRAE 62.1 at the corresponding supply air blower speeds.

- When supply air blower is off or the unit is in unoccupied mode, the outdoor air damper is closed.
- When unit is in occupied mode and supply air blower is operating at a speed below the “midpoint” blower speed, the outdoor air damper is at minimum “low blower” position.
- When unit is in occupied mode and supply air blower is operating at a speed equal to or above the “midpoint” blower speed, the outdoor air damper is at minimum “high blower” position.

*NOTE - The “midpoint” blower speed is an average of the minimum and maximum blower speed (minimum speed + maximum speed divided by 2).*

**Power Exhaust Operation**

*NOTE - Power exhaust operation is the same for all control options*

Power exhaust blower operates when economizer outdoor air dampers are 50% open (adjustable) and when supply air blower speed is above 70% (adjustable) of full speed.

**Objective:** Outline the unit functions as a result of room thermostat or zone sensor demands.

**Given:** When economizer is present, it will function as an integral part of the unit cooling system. When not present, unit will function as if economizer is present but outdoor ambient is high and sensed as not suitable.

### **UNIT WITH 2-STAGE THERMOSTAT (2 COOLING STAGES, Y1, Y2)**

#### **SUPPLY AIR BLOWER SPEED**

Unit has the following supply air blower speed settings:

- Ventilation Speed
- Cooling Speed - Low
- Cooling Speed - High
- Heating Speed
- Smoke Speed (Used only in smoke removal option - not discussed)

#### **<sup>1</sup> Unit Features An Economizer And Outdoor Air Is Suitable**

##### **Y1 Demand:**

All compressors are off, supply air blower is on low cooling speed to minimize blower power consumption, economizer modulates (minimum to maximum open position) to maintain 55°F supply air temperature (default unit controller setting).

##### **Y2 Demand:**

All compressors are off, supply air blower is on high cooling speed providing higher cooling capacity, and economizer modulates to maintain 55°F supply air temperature.

If economizer stays at maximum open for 3 minutes, 1st stage compressors (compressor 1 and 2) are energized while supply air blower stays on high cooling speed providing maximum cooling capacity.

<sup>1</sup> Outdoor air suitability is determined by the energy state of outdoor ambient (enthalpy or sensible) and its ability to achieve the desired free cooling effects. Outdoor air suitability can also be determined by a third party controller and provided to the RTU via a network connection.

#### **Unit Does Not Feature An Economizer Or Outdoor Air Is Not Suitable**

##### **Y1 Demand:**

1st stage compressors operate and supply air blower operates at low cooling speed.

##### **Y2 Demand:**

All compressors operate and supply air blower operates at high cooling speed.

#### **Dehumidification Mode**

If a unit with Humiditrol® Dehumidification Option receives a call for dehumidification, economizer free cooling is locked out.

##### **Call For Dehumidification, No Y1, Y2 Demand:**

1st stage compressors (1 & 2) operate, supply air blower operates at low cooling speed, and the reheat valves are energized.

##### **Y1 Demand With A Call For Dehumidification:**

All compressors operate, supply air blower operates at high cooling speed and the reheat valves are energized.

##### **Y2 Demand With A Call For Dehumidification:**

All compressors operate, supply air blower operates at high cooling speed, and the reheat valves are de-energized.



**UNIT WITH ZONE SENSOR (4 COOLING STAGES, Y1, Y2, Y3, Y4)****SUPPLY AIR BLOWER SPEED**

Unit has following supply air blower speed setting:

- Ventilation Speed
- Cooling Speed - Low
- Cooling Speed - Medium-Low
- Cooling Speed - Medium-High
- Cooling Speed - High
- Heating Speed
- Smoke Speed (Used only in smoke removal option - not discussed)

**<sup>1</sup> Unit Features An Economizer And Outdoor Air Is Suitable****Y1 Demand:**

All compressors are off, supply air blower is on low cooling speed to minimize blower power consumption, economizer modulates (minimum to maximum open position) to maintain 55°F supply air temperature (default unit controller setting).

**Y2 Demand:**

All compressors are off, supply air blower is on high cooling speed providing higher cooling capacity, and economizer modulates to maintain 55°F supply air temperature.

If economizer stays at maximum open for 3 minutes, compressor 1 is energized while supply air blower stays on high cooling speed. After compressor 1 is energized the economizer stays at maximum open.

**Y3 Demand:**

Compressor 1 and 2 are energized while supply air blower is on high cooling speed providing even higher cooling capacity.

**Y4 Demand:**

All compressors are energized while supply air blower is on high cooling speed providing maximum cooling capacity.

<sup>1</sup> Outdoor air suitability is determined by the energy state of outdoor ambient (enthalpy or sensible) and its ability to achieve the desired free cooling effects. Outdoor air suitability can also be determined by a third party controller and provided to the RTU via a network connection.

**Unit Does Not Feature An Economizer Or Outdoor Air Is Not Suitable****Y1 Demand:**

Compressor 1 operates and supply air blower operates at low cooling speed.

**Y2 Demand:**

Compressors 1 and 2 operate and supply air blower operates at medium-low cooling speed.

**Y3 Demand:**

Compressors 1, 2, and 3 operate and supply air blower operates at medium-high cooling speed.

**Y4 Demand:**

All compressors operate and supply air blower operates at high cooling speed.

**UNIT WITH ZONE SENSOR (4 COOLING STAGES, Y1, Y2, Y3, Y4) (CONTINUED)****Dehumidification Mode**

If a unit with Humiditrol® Dehumidification Option receives a call for dehumidification, economizer free cooling is locked out.

**Call For Dehumidification, No Y1, Y2, Y3, Y4 Demand:**

Compressors 1 and 2 operate, supply air blower operates at medium-low cooling speed, and both reheat valves are energized.

**Y1 Demand With A Call For Dehumidification:**

Compressors 1, 2, and 3 operate, supply air blower operates at high cooling speed and both reheat valves are energized.

**Y2 Demand With A Call For Dehumidification:**

All compressors operate, supply air blower operates at high cooling speed and both reheat valves are energized.

**Y3 Demand With A Call For Dehumidification:**

All compressors operate, supply air blower operates at high cooling speed, and the reheat valve of compressor 1 is energized while the reheat valve of compressor 2 is de-energized.

**Y4 Demand With A Call For Dehumidification:**

All compressors operate, supply air blower operates at high cooling speed, and the reheat valves are de-energized.

**Heating Mode (Electric Heat)**

*NOTE - Heating mode is the same for all control options.*

**W1 Demand:**

1st stage electric heat is energized and the supply air blower operates at heating speed.

**W2 Demand:**

2nd stage electric heat is energized and the supply air blower operates at heating speed (45, 60 or 90 kW electric heat option only).

**Modulating Outdoor Air Damper**

The minimum damper position for “occupied low blower” and “occupied high blower” is adjusted during unit setup to provide minimum fresh air requirements per ASHRAE 62.1 at the corresponding supply air blower speeds.

- When supply air blower is off or the unit is in unoccupied mode, the outdoor air damper is closed.
- When unit is in occupied mode and supply air blower is operating at a speed below the “midpoint” blower speed, the outdoor air damper is at minimum “low blower” position.
- When unit is in occupied mode and supply air blower is operating at a speed equal to or above the “midpoint” blower speed, the outdoor air damper is at minimum “high blower” position.

*NOTE - The “midpoint” blower speed is an average of the minimum and maximum blower speed (minimum speed + maximum speed divided by 2).*

**Power Exhaust Operation**

*NOTE - Power exhaust operation is the same for all control options*

MSAV® models are equipped with 2-stage power exhaust fans. Power exhaust fans operate when economizer outdoor air dampers are 50% open (adjustable). Power exhaust operates in 1st stage (one fan) up to 70% of supply air blower speed. 2nd stage power exhaust fans (both fans) operate when supply air blower speed is above 70% (adjustable) of full speed.

## OPTIONS / ACCESSORIES

Item Description	Model Number	Catalog Number	Unit Model No.			
			036	060	120	240
<b>COOLING SYSTEM</b>						
Condensate Drain Trap		Factory	O	O	O	O
Corrosion Protection	Coated indoor/outdoor coil assemblies, painted cabinet interior	Factory	O	O	O	O
	Coated outdoor coil assembly	Factory	O	O	O	O
Drain Pan Overflow Switch	E1SNSR71AD1	<b>68W88</b>	OX	OX	OX	OX
<b>BLOWER - SUPPLY AIR</b>						
ECM Direct Drive, MSAV® (Multi-Stage Air Volume)	1.5 hp	Factory	O	O		
Belt Drive, MSAV® (Multi-Stage Air Volume)	3 hp	Factory			O	
	5 hp	Factory				O
	7.5 hp	Factory				O
<b>CABINET</b>						
Combination Coil/Hail Guards	S1GARD22101	<b>19H54</b>	OX	OX		
	S1GARD22111	<b>19H55</b>			OX	
	C1GARD52D-1	<b>13T16</b>				OX
<b>CONTROLS</b>						
Blower Proving Switch		Factory	O	O	O	O
Commercial Controls	Prodigy® Control System - BACnet® Module	Factory	O	O	O	O
	Prodigy® Control System - LonTalk® Module	Factory	O	O	O	O
	CPC Einstein Integration	Factory	O	O	O	O
	L Connection® Network	Factory	O	O	O	O
Dirty Filter Switch	S1SNSR55S-1	<b>12P68</b>	OX	OX	OX	OX
Fresh Air Tempering	C1SNSR75AD1	<b>58W63</b>	X	X	X	X
<sup>1</sup> Smoke Detector	Supply	Factory	O	O	O	O
	Return	Factory	O	O	O	O
<b>ELECTRICAL</b>						
Voltage 60 hz	208/230V - 3 phase	Factory	O	O	O	O
	460V - 3 phase	Factory	O	O	O	O
	575V - 3 phase	Factory	O	O	O	O
GFI Service Outlets	20 amp non-powered, field-wired (all voltages) C1GFIC20FF1	<b>67E01</b>	OX	OX	OX	OX
	15 amp, factory-wired and powered C1GFIC15FF1	<b>74M70</b>				O
<sup>2</sup> Short-Circuit Current Rating (SCCR) of 100kA (includes Phase/Voltage Detection)		Factory				O
Weatherproof Cover for GFI	C1GFIC99FF1	<b>10C89</b>	X	X	X	X
<b>ELECTRIC HEAT</b>						
15 kW	208/230V, 460V or 575V-3ph	Factory	O	O	O	
30 kW	208/230V, 460V or 575V-3ph	Factory		O	O	O
45 kW	208/230V or 575V-3ph	Factory			O	
60 kW	208/230V or 575V-3ph	Factory			O	O
90 kW	208/230V or 575V-3ph	Factory				O
10 kW	460V-3ph	Factory	O	O		
20 kW	460V-3ph	Factory		O	O	O
40 kW	460V-3ph	Factory			O	O
80 kW	460V-3ph	Factory				O
<b>HUMIDITROL® CONDENSER REHEAT OPTION</b>						
Humiditrol® Dehumidification Option		Factory	O	O	O	O
Humidity Sensor Kit, Remote mounted (required)	C0SNSR31AE-1	<b>17M50</b>	X	X	X	X

<sup>1</sup> Factory installed smoke detectors must be ordered for use with either 115V or 24V external power supply only.

<sup>2</sup> SCCR option not available with 90 kW - 208/230V electric heat option.

NOTE - Catalog and model numbers shown are for ordering field installed accessories.

OX - Configure To Order (Factory Installed) or Field Installed

O = Configure To Order (Factory Installed)

X = Field Installed

## OPTIONS / ACCESSORIES

Item Description	Model Number	Catalog Number	Unit Model No.			
			036	060	120	240
<b>INDOOR AIR QUALITY</b>						
<b>Air Filters</b>						
Healthy Climate®	MERV 13 (16 x 20 x 2 - Order 4 per unit)	C1FLTR40A-1	52W37	X	X	
High Efficiency Air Filters	MERV 13 (20 x 25 x 2 - Order 4 per unit)	C1FLTR40B-1	52W41			X
	MERV 13 (20 x 20 x 2 - Order 12 per unit)	C1FLTR40D-1	52W39			X
Replacement Media Filter With Metal Mesh Frame 20 x 20 x 2 Order 12 per unit (includes non-pleated filter media)		C1FLTR30D-1	44N60			X
<b>Indoor Air Quality (CO<sub>2</sub>) Sensors</b>						
Sensor - Wall-mount, off-white plastic cover with LCD display		C0SNSR50AE1L	77N39	X	X	X X
Sensor - Wall-mount, off-white plastic cover, no display		C0SNSR52AE1L	87N53	X	X	X X
Sensor - Black plastic case with LCD display, rated for plenum mounting		C0SNSR51AE1L	87N52	X	X	X X
Sensor - Wall-mount, black plastic case, no display, rated for plenum mounting		C0MISC19AE1	87N54	X	X	X X
CO <sub>2</sub> Sensor Duct Mounting Kit - for downflow applications		C0MISC19AE1-	85L43	X	X	X X
Aspiration Box - for duct mounting non-plenum rated CO <sub>2</sub> sensors (87N53 or 77N39)		C0MISC16AE1-	90N43	X	X	X X
<b>ECONOMIZER</b>						
<b>High Performance Economizer (Approved for California Title 24 Building Standards / AMCA Class 1A Certified)</b>						
High Performance Economizer - Includes Outdoor Air Hood (Global Sensor, field provided, order Barometric Relief Dampers separately)		E1ECON17D-2	Factory 18X87	O	O	O OX
<b>Economizer Controls (Not for Title 24)</b>						
Single Enthalpy NOTE - For Differential Enthalpy Order 2 Single Enthalpy Controls		C1SNSR64FF1	53W64	OX	OX	OX OX
<b>Barometric Relief Dampers</b>						
	Barometric Relief Dampers (No Hood)		30W72	OX	OX	
	Barometric Relief Dampers With Power Exhaust Fans (Hood Furnished)		30W92			OX
	Barometric Relief Dampers Without Power Exhaust Fans (No Hood)		47M14			OX
	Barometric Relief Dampers Without Power Exhaust Fans (Hood Furnished)		76W17			OX
<b>POWER EXHAUST</b>						
Standard Static			Factory			O O
<b>OUTDOOR AIR</b>						
Manual Outdoor Air Damper with Outdoor Air Hood and Bird Screen			Factory			O
Motorized Outdoor Air Dampers with Outdoor Air Hood and Bird Screen			Factory			O
<b>ROOF CURBS</b>						
Hybrid Roof Curbs, Downflow, 14 in. height		S1CURB71101	11F70	X	X	
		S1CURB71111	11F72			X
		Full Perimeter - S1CURB71121	11F74			X
Hybrid Roof Curbs, Downflow 24 in. height		S1CURB73101	11F71	X	X	
		S1CURB73111	11F73			X
		Full Perimeter - S1CURB73121	11F75			X
Curb Alignment (Adapter plate mates new unit to existing roof curb for replacement of LCE240)			Factory			O

NOTE - Catalog and model numbers shown are for ordering field installed accessories.  
OX - Configure To Order (Factory Installed) or Field Installed  
O = Configure To Order (Factory Installed)  
X = Field Installed

SPECIFICATIONS		DIRECT DRIVE   3 - 5 TON	
General Data	Nominal Tonnage	3 Ton	5 Ton
	Model No.	SCH036H4E	SCH060H4E
	Efficiency Type	High	High
	Blower Type	ECM Direct Drive MSAV® (Multi-Stage Air Volume)	ECM Direct Drive MSAV® (Multi-Stage Air Volume)
Cooling Performance	Gross Cooling Capacity - Btuh	37,200	60,300
	<sup>1</sup> Net Cooling Capacity - Btuh	36,000	59,000
	AHRI Rated Air Flow - cfm	1200	1700
	Total Unit Power - kW	2.6	4.5
	<sup>1</sup> SEER (Btuh/Watt) - 208/230V-3ph	19.3	17.8
	<sup>1</sup> SEER (Btuh/Watt) - 460V/575V-3ph	18.6	17.4
	<sup>1</sup> EER (Btuh/Watt) - 208/230V-3ph	14.2	13.0
	<sup>1</sup> EER (Btuh/Watt) - 460V/575V-3ph	13.9	12.8
Refrigerant Charge	Refrigerant Type	R-410A	R-410A
	Environ™ Coil System	7 lbs. 11 oz.	8 lbs. 3 oz.
	Environ™ Coil System With Humiditrol® Dehumidification Option	8 lbs. 4 oz.	8 lbs. 4 oz.
<sup>2</sup> Sound Rating Number (dBA)		67	78
Electric Heat Options Available (See page 22)		10, 15 kW	10, 15, 20, 30 kW
Compressor Type (No.)		Two-Stage Scroll (1)	Two-Stage Scroll (1)
Condenser Coil	Net face area - sq. ft.	18.7	18.7
	Number of rows	1	1
	Fins per inch	23	23
Condenser Fan(s)	Motor (No.) horsepower	(2) 1/3 (ECM)	(2) 1/3 (ECM)
	Motor rpm	340-560	340-860
	Total Motor watts	90-136	90-354
	Diameter (No.) - in.	(2) 24	(2) 24
	Number of blades	3	3
	Total air volume - cfm	3900	6300
Evaporator Coil	Net face area - sq. ft.	7.78	7.78
	Tube diameter - in.	3/8	3/8
	Number of rows	4	4
	Fins per inch	14	14
	Drain connection - no. & size	(1) 1 NPT	(1) 1 NPT
	Expansion device type	Balance Port TXV, removable head	
<sup>3</sup> Indoor Blower	Nominal motor output HP	1.5 (ECM)	1.5 (ECM)
	Wheel nominal diameter x width - in.	(1) 14 x 5	(1) 14 x 5
Filters	Type of filter	MERV 8 or equivalent	
	Number and size - in.	(4) 16 x 20 x 2	(4) 16 x 20 x 2
Electrical characteristics		208/230V, 460V, or 575V - 60 hertz - 3 phase	

NOTE - Net capacity includes evaporator blower motor heat deduction. Gross capacity does not include evaporator blower motor heat deduction.

<sup>1</sup> AHRI Certified to AHRI Standard 210/240; 95°F outdoor air temperature and 80°F db/67°F wb entering evaporator air; minimum external duct static pressure.

<sup>2</sup> Sound Rating Number rated in accordance with test conditions included in AHRI Standard 270-95.

<sup>3</sup> Using total air volume and system static pressure requirements determine from blower performance tables rpm and motor output required. Maximum usable output of motors furnished are shown. In Canada, nominal motor output is also maximum usable motor output. If motors of comparable output are used, be sure to keep within the service factor limitations outlined on the motor nameplate.



SPECIFICATIONS		BELT DRIVE   10 - 20 TON			
General Data	Nominal Tonnage	10 Ton		20 Ton	
	Model No.	SCH120H4M		SCH240H4M	
	Efficiency Type	High		High	
	Blower Type	MSAV® (Multi-Stage Air Volume) (Belt Drive)		MSAV® (Multi-Stage Air Volume) (Belt Drive)	
Cooling Performance	Gross Cooling Capacity - Btuh	121,000		239,000	
	<sup>1</sup> Net Cooling Capacity - Btuh	117,000		232,000	
	AHRI Rated Air Flow - cfm	3800		7000	
	Total Unit Power - kW	9.9		19.3	
	<sup>1</sup> EER (Btuh/Watt)	11.8		12.0	
	<sup>1</sup> IEER (Btuh/Watt)	15.6		16.8	
Refrigerant Charge	Refrigerant Type		R-410A		
	Environ™ Coil System	Circuit 1	9 lbs. 6 oz.		8 lbs. 8 oz.
		Circuit 2	6 lbs. 1 oz.		8 lbs. 6 oz.
		Circuit 3	---		6 lbs. 13 oz.
		Circuit 4	---		7 lbs. 0 oz.
	Environ™ Coil System With Humiditrol® Dehumidification Option	Circuit 1	10 lbs. 0 oz.		8 lbs. 8 oz.
		Circuit 2	6 lbs. 1 oz.		8 lbs. 6 oz.
		Circuit 3	---		6 lbs. 13 oz.
		Circuit 4	---		7 lbs. 0 oz.
	<sup>2</sup> Sound Rating Number (dBA)		89		92
Electric Heat Options Available (See page 22)		15, 20, 30, 40, 45, 60 kW		20, 30, 40, 60, 80, 90 kW	
Compressor Type (No.)		Scroll (2)		Scroll (4)	
Condenser Coil	Net face area - sq. ft.	45.7		68.3	
	Fins per inch	23		23	
Condenser Fan(s)	Motor (No.) horsepower	(2) 1/2		(6) 1/3	
	Motor rpm	1075		1075	
	Total Motor watts	1160		1900	
	Diameter (No.) - in.	(2) 24		(6) 24	
	Number of blades	4		3	
	Total air volume - cfm	10,000		22,500	
Evaporator Coil	Net face area - sq. ft.	13.54		32.2	
	Tube diameter - in.	3/8		3/8	
	Number of rows	4		3	
	Fins per inch	14		14	
	Drain connection - no. & size	(1) 1 NPT		(1) 1 NPT	
	Expansion device type	Balance Port TXV, removable head			
<sup>3</sup> Indoor Blower	Nominal motor HP	3		5	7.5
	RPM Range (Standard Static)	Drive #3 - 660-900 rpm	Drive #4 - 520-685 rpm	Drive #7 - 770-965 rpm	
	RPM Range (High Static)	Drive #4 - 865-1080 rpm	Drive #5 - 685-865 rpm	---	
	Wheel nominal diameter x width - in.	(1) 15 x 15	(2) 18 x 15	(2) 18 x 15	
Filters	Type of filter	MERV 8 or equivalent			
	Number and size - in.	(4) 20 x 25 x 2		(12) 20 x 20 x 2	
Electrical characteristics		208/230V, 460V, or 575V - 60 hertz - 3 phase			

NOTE - Net capacity includes evaporator blower motor heat deduction. Gross capacity does not include evaporator blower motor heat deduction.

<sup>1</sup> AHRI Certified to AHRI Standard 340/360: 95°F outdoor air temperature and 80°F db/67°F wb entering evaporator air; minimum external duct static pressure..

<sup>2</sup> Sound Rating Number rated in accordance with test conditions included in AHRI Standard 270-95.

<sup>3</sup> Using total air volume and system static pressure requirements determine from blower performance tables rpm and motor output required. Maximum usable output of motors furnished are shown. In Canada, nominal motor output is also maximum usable motor output. If motors of comparable output are used, be sure to keep within the service factor limitations outlined on the motor nameplate.

NOTE – Units equipped with MSAV® (Multi-Stage Air Volume) are limited to a motor service factor of 1.0.

**SPECIFICATIONS****PRODIGY® CONTROL SYSTEM**

Operating Environment	Temperature: -40°F to 155°F
	Humidity: 10% - 95% RH, Non- Condensing
Power Requirements	24VAC (+/-25%), 50/60Hz
	4.8 VA for M2 maximum
	14.4 VA for M2 w/all expansion boards Maximum
Memory Type	Re-programmable Flash
Device Commissioning	Auto-poll (real plug and play)
Unit type	Electric/Electric, Gas/Electric & Heat Pumps (Rooftops)
Cooling stages	4
Heating stages	4
Modulating Gas Valves	2
Electronic Configure To Order Parameters	239
Alarm Codes	107
Alarm Codes Stored	84
Display Type	Scrolling, 7 plus Character Red LED
Indicator LEDs	1- Heartbeat on each board
	1- Bus transmit
	1 - Bus receive
	1- each for Y1,Y2,W1,W2,G,OCP
Dimensions - Main Board	Main Board: Height: 8 in., Width: 14-1/2 in., Depth: 6 in.
Weight	2 lbs. for M2 w/all modules installed
Cable Type	SysBus - Lennox yellow COMM cable: C0MISC00AE1- (27M19) (500 ft. box), C0MISC04AE1- (94L63) (1000 ft. box), C0MISC01AE1- (68M25) (2500 ft. roll) ZoneBus - Lennox purple COMM cable: C0MISC05AE1- (23W99) (500 ft. box) C0MISC06AE1- (24W00) (1000 ft



# RATINGS

NOTE - For Temperatures and Capacities not shown in tables, see bulletin - Cooling Unit Rating Table Correction Factor Data in Miscellaneous Engineering Data section.

## 10 TON HIGH EFFICIENCY SCH120H4M (ONE COMPRESSOR OPERATING)

Entering Wet Bulb Temperature	Total Air Volume	Outdoor Air Temperature Entering Outdoor Coil																			
		65°F					75°F					85°F					95°F				
		Total Cool Cap.	Comp. Motor Input	Sensible To Total Ratio (S/T)			Total Cool Cap.	Comp. Motor Input	Sensible To Total Ratio (S/T)			Total Cool Cap.	Comp. Motor Input	Sensible To Total Ratio (S/T)			Total Cool Cap.	Comp. Motor Input	Sensible To Total Ratio (S/T)		
				Dry Bulb					Dry Bulb					Dry Bulb					Dry Bulb		
cfm	kBtuh	kW	75°F	80°F	85°F	kBtuh	kW	75°F	80°F	85°F	kBtuh	kW	75°F	80°F	85°F	kBtuh	kW	75°F	80°F	85°F	
63°F	2000	69.2	2.66	0.75	0.9	1	65	2.99	0.76	0.92	1	60.7	3.36	0.77	0.94	1	56.1	3.8	0.78	0.96	1
	2400	72.4	2.68	0.8	0.97	1	67.9	3.01	0.81	0.99	1	63.6	3.38	0.83	1	1	59.5	3.82	0.85	1	1
	2800	75.3	2.7	0.85	1	1	71.3	3.03	0.86	1	1	67.1	3.41	0.88	1	1	62.7	3.84	0.91	1	1
67°F	2000	74.3	2.69	0.59	0.73	0.87	69.9	3.02	0.58	0.73	0.88	65.3	3.39	0.58	0.75	0.9	60.7	3.82	0.58	0.76	0.93
	2400	77.5	2.71	0.62	0.78	0.93	72.9	3.04	0.62	0.79	0.96	68.1	3.41	0.62	0.8	0.98	63.2	3.84	0.62	0.82	1
	2800	79.9	2.73	0.65	0.83	0.99	75.2	3.05	0.65	0.84	1	70.2	3.43	0.66	0.86	1	65.1	3.85	0.66	0.89	1
71°F	2000	79.2	2.73	0.44	0.57	0.71	74.6	3.05	0.43	0.57	0.71	69.9	3.42	0.42	0.57	0.72	65	3.85	0.41	0.58	0.73
	2400	82.6	2.75	0.45	0.61	0.75	77.8	3.07	0.45	0.61	0.77	72.9	3.44	0.44	0.61	0.78	67.9	3.87	0.43	0.62	0.8
	2800	85.3	2.77	0.47	0.64	0.8	80.3	3.09	0.46	0.64	0.82	75.2	3.46	0.45	0.65	0.84	70	3.89	0.45	0.66	0.86

## 10 TON HIGH EFFICIENCY SCH120H4M (ALL COMPRESSOR OPERATING)

Entering Wet Bulb Temperature	Total Air Volume	Outdoor Air Temperature Entering Outdoor Coil																			
		85°F					95°F					105°F					115°F				
		Total Cool Cap.	Comp. Motor Input	Sensible To Total Ratio (S/T)			Total Cool Cap.	Comp. Motor Input	Sensible To Total Ratio (S/T)			Total Cool Cap.	Comp. Motor Input	Sensible To Total Ratio (S/T)			Total Cool Cap.	Comp. Motor Input	Sensible To Total Ratio (S/T)		
				Dry Bulb					Dry Bulb					Dry Bulb					Dry Bulb		
cfm	kBtuh	kW	75°F	80°F	85°F	kBtuh	kW	75°F	80°F	85°F	kBtuh	kW	75°F	80°F	85°F	kBtuh	kW	75°F	80°F	85°F	
63°F	3200	117.4	6.72	0.72	0.86	0.98	109	7.58	0.73	0.87	1	100.2	8.59	0.74	0.89	1	91.1	9.72	0.73	0.91	1
	4000	123.6	6.75	0.78	0.93	1	115	7.62	0.78	0.95	1	106.2	8.62	0.8	0.97	1	96.7	9.76	0.82	1	1
	4800	128.9	6.78	0.83	0.99	1	120.3	7.65	0.84	1	1	111.7	8.66	0.86	1	1	102.4	9.8	0.89	1	1
67°F	3200	125.4	6.76	0.56	0.7	0.83	116.6	7.63	0.55	0.71	0.84	107.6	8.63	0.55	0.7	0.86	97.7	9.76	0.55	0.72	0.88
	4000	131.7	6.8	0.59	0.74	0.9	122.5	7.67	0.59	0.76	0.92	112.8	8.66	0.59	0.77	0.94	102.6	9.8	0.6	0.79	0.97
	4800	136.2	6.83	0.62	0.8	0.97	126.6	7.69	0.64	0.81	0.99	116.5	8.69	0.64	0.85	1	106	9.83	0.65	0.88	1
71°F	3200	133.3	6.81	0.41	0.55	0.67	124.1	7.67	0.4	0.55	0.68	115	8.68	0.38	0.54	0.69	105	9.83	0.37	0.54	0.69
	4000	140	6.85	0.43	0.58	0.73	130.6	7.72	0.42	0.58	0.74	120.6	8.71	0.41	0.59	0.76	110.1	9.86	0.4	0.6	0.77
	4800	145	6.88	0.44	0.61	0.78	135	7.74	0.43	0.62	0.8	125	8.75	0.42	0.62	0.82	114	9.9	0.41	0.63	0.84







# HUMIDITROL® DEHUMIDIFICATION SYSTEM RATINGS

## 20 TON HIGH EFFICIENCY SCH240H4E WITH HUMIDITROL® OPERATING (1ST STAGE) - MSAV®

Entering Wet Bulb Temperature	Total Air Volume	Outdoor Air Temperature Entering Outdoor Coil																				
		65°F						75°F					85°F					95°F				
		Total Cool Cap.	Comp. Motor Input	Sensible To Total Ratio (S/T)			Total Cool Cap.	Comp. Motor Input	Sensible To Total Ratio (S/T)			Total Cool Cap.	Comp. Motor Input	Sensible To Total Ratio (S/T)			Total Cool Cap.	Comp. Motor Input	Sensible To Total Ratio (S/T)			
				Dry Bulb					Dry Bulb					Dry Bulb					Dry Bulb			
		cfm	kBtuh	kW	75°F	80°F	85°F	kBtuh	kW	75°F	80°F	85°F	kBtuh	kW	75°F	80°F	85°F	kBtuh	kW	75°F	80°F	85°F
63°F	3200	75.3	5.5	0.49	0.71	0.92	60.9	6.0	0.42	0.65	0.88	44.2	6.6	0.28	0.58	0.88	25.6	7.2	0.01	0.49	0.88	
	4000	79.1	5.6	0.57	0.76	0.95	62.6	6.0	0.50	0.72	0.94	44.7	6.6	0.37	0.66	0.94	27.1	7.3	0.06	0.50	0.94	
	4800	82.9	5.6	0.64	0.81	0.99	64.2	6.1	0.59	0.79	1.00	45.2	6.6	0.47	0.74	1.00	28.6	7.3	0.11	0.51	1.00	
67°F	3200	87.5	5.7	0.30	0.49	0.67	69.5	6.1	0.20	0.43	0.66	51.0	6.7	0.03	0.32	0.62	30.4	7.4	0.32	0.43	0.55	
	4000	88.2	5.7	0.33	0.55	0.75	69.9	6.2	0.22	0.50	0.75	51.4	6.7	0.03	0.39	0.74	32.2	7.4	0.43	0.53	0.71	
	4800	94.1	5.8	0.36	0.59	0.82	72.9	6.2	0.25	0.55	0.85	52.7	6.7	0.03	0.44	0.85	37.3	7.4	0.55	0.70	0.86	
71°F	3200	101.8	5.8	0.14	0.31	0.47	84.3	6.3	0.02	0.22	0.42	66.9	6.9	0.17	0.25	0.34	45.1	7.5	0.49	0.34	0.20	
	4000	105.0	5.9	0.15	0.34	0.53	86.5	6.3	0.02	0.25	0.48	67.1	6.9	0.19	0.30	0.41	46.8	7.5	0.57	0.42	0.27	
	4800	108.1	5.9	0.15	0.36	0.58	88.6	6.3	0.02	0.28	0.54	67.3	6.9	0.21	0.35	0.48	48.5	7.6	0.65	0.50	0.34	

## 20 TON HIGH EFFICIENCY SCH240H4E WITH HUMIDITROL® OPERATING (2ND STAGE) - MSAV®

Entering Wet Bulb Temperature	Total Air Volume	Outdoor Air Temperature Entering Outdoor Coil																				
		65°F						75°F					85°F					95°F				
		Total Cool Cap.	Comp. Motor Input	Sensible To Total Ratio (S/T)			Total Cool Cap.	Comp. Motor Input	Sensible To Total Ratio (S/T)			Total Cool Cap.	Comp. Motor Input	Sensible To Total Ratio (S/T)			Total Cool Cap.	Comp. Motor Input	Sensible To Total Ratio (S/T)			
				Dry Bulb					Dry Bulb					Dry Bulb					Dry Bulb			
		cfm	kBtuh	kW	75°F	80°F	85°F	kBtuh	kW	75°F	80°F	85°F	kBtuh	kW	75°F	80°F	85°F	kBtuh	kW	75°F	80°F	85°F
63°F	6400	189.6	10.5	0.57	0.74	0.91	164.1	11.6	0.55	0.73	0.91	138.0	13.0	0.51	0.70	0.90	108.6	14.5	0.46	0.70	0.94	
	8000	198.4	10.7	0.62	0.79	0.95	172.4	11.7	0.61	0.78	0.94	142.9	13.0	0.58	0.76	0.93	108.8	14.5	0.57	0.76	0.95	
	9600	207.1	10.9	0.68	0.83	0.99	180.6	11.7	0.67	0.83	0.98	147.8	13.0	0.66	0.81	0.97	108.9	14.5	0.67	0.82	0.97	
67°F	6400	212.2	10.7	0.39	0.55	0.72	183.7	11.9	0.34	0.53	0.71	155.8	13.2	0.28	0.49	0.71	123.2	14.8	0.18	0.45	0.72	
	8000	222.1	10.8	0.42	0.61	0.78	190.2	11.9	0.37	0.60	0.78	158.3	13.2	0.30	0.57	0.78	124.5	14.7	0.21	0.53	0.77	
	9600	226.1	11.0	0.44	0.65	0.85	194.3	11.9	0.40	0.63	0.85	160.3	13.2	0.33	0.59	0.84	122.8	14.7	0.23	0.53	0.83	
71°F	6400	235.1	11.0	0.24	0.39	0.54	205.6	12.2	0.18	0.35	0.51	175.5	13.5	0.10	0.29	0.49	145.0	15.0	0.02	0.23	0.45	
	8000	242.3	11.1	0.24	0.41	0.59	213.1	12.1	0.18	0.38	0.57	179.6	13.4	0.09	0.32	0.55	145.2	14.9	0.05	0.28	0.52	
	9600	249.5	11.3	0.24	0.44	0.64	220.6	12.1	0.18	0.41	0.63	183.7	13.3	0.08	0.35	0.62	145.4	14.8	0.08	0.33	0.59	

**BLOWER DATA**

**DIRECT DRIVE | 3 - 5 TON**

**SCH036H / SCH060H BLOWER PERFORMANCE**

NOTE - Blower Table Includes Resistance For Base Unit With Electric Heat, Wet Indoor Coil And Air Filters In Place.

NOTE - MINIMUM AIR VOLUME REQUIRED FOR USE WITH OPTIONAL ELECTRIC HEAT:

SCH036H - 1020 CFM

SCH060H - 1650 CFM

**EXTERNAL STATIC PRESSURE - In. w.g.**

Air Volume cfm	0.1		0.2		0.3		0.4		0.5		0.6		0.7		0.8		0.9		1.0		1.1		1.2		1.3		1.4	
	RPM	Watts	RPM	Watts	RPM	Watts	RPM	Watts	RPM	Watts	RPM	Watts	RPM	Watts	RPM	Watts	RPM	Watts	RPM	Watts	RPM	Watts	RPM	Watts	RPM	Watts	RPM	Watts
900	1214	116	1294	144	1371	170	1444	194	1513	218	1578	240	1640	262	1699	283	1754	303	1808	322	1859	341	1911	360	1962	382	2014	405
1000	1308	144	1388	171	1463	196	1534	220	1601	243	1664	266	1723	288	1780	310	1834	331	1887	352	1938	373	1989	395	2040	419	2091	445
1100	1407	172	1485	198	1558	223	1627	247	1691	271	1752	294	1809	317	1864	339	1916	362	1968	385	2018	409	2068	434	2119	460	2169	489
1200	1512	201	1587	227	1657	252	1723	277	1784	301	1842	325	1897	349	1950	373	2001	398	2051	423	2101	449	2150	476	2199	505	2249	536
1300	1623	232	1693	258	1759	284	1822	309	1880	335	1935	360	1988	386	2039	412	2089	438	2138	466	2186	494	2234	524	2282	554	2329	586
1400	1738	266	1803	293	1865	320	1923	347	1979	373	2031	401	2082	428	2131	456	2179	485	2227	514	2274	545	2320	575	2366	607	2411	641
1500	1855	305	1915	333	1973	361	2028	389	2080	418	2130	447	2178	477	2226	507	2273	537	2318	568	2363	600	2408	632	2451	665	2495	699
1600	1973	349	2029	379	2083	408	2134	438	2183	469	2231	500	2277	531	2323	563	2368	595	2412	627	2455	660	2497	693	2539	727	2579	762
1700	2090	399	2143	430	2193	462	2241	494	2287	526	2333	558	2377	591	2421	624	2464	658	2506	691	2547	725	2588	759	2627	794	2666	829
1800	2206	456	2255	488	2303	522	2348	555	2392	589	2436	623	2478	657	2520	691	2561	725	2601	760	2640	795	2679	830	2716	865	2753	901
1900	2321	519	2368	553	2412	588	2455	622	2498	657	2539	692	2579	727	2619	762	2658	798	2696	833	2734	869	2770	905	2806	941	2841	978
2000	2435	589	2479	624	2521	660	2562	695	2602	731	2642	767	2680	803	2718	839	2755	875	2791	911	2827	947	2862	984	2896	1021	2931	1058
2100	2547	665	2589	701	2629	737	2668	774	2706	810	2744	847	2780	883	2816	919	2851	956	2886	992	2920	1029	2954	1066	2987	1103	3021	1140
2200	2659	746	2698	783	2736	820	2773	857	2809	894	2844	931	2879	967	2913	1003	2947	1040	2980	1076	3013	1112	3046	1149	3080	1185	3113	1221
2300	2770	834	2806	871	2842	908	2877	945	2911	981	2945	1017	2978	1053	3010	1089	---	---	---	---	---	---	---	---	---	---	---	---
2400	2879	925	2913	962	2947	999	2980	1035	3012	1070	---	---	---	---	---	---	---	---	---	---	---	---	---	---	---	---	---	---
2500	2987	1020	3019	1055	---	---	---	---	---	---	---	---	---	---	---	---	---	---	---	---	---	---	---	---	---	---	---	---

**BLOWER DATA**

**BELT DRIVE | 10 TON**

**SCH120HM BLOWER PERFORMANCE**

NOTE - Blower Table Includes Resistance For Base Unit With Electric Heat, Wet Indoor Coil And Air Filters In Place.

NOTE - MINIMUM AIR VOLUME REQUIRED FOR USE WITH OPTIONAL ELECTRIC HEAT - 3800 CFM.

See Blower Motor / Drive Kit Table on page 35 for Motor HP and Drive Kit RPM Ranges Available.

Air Volume cfm	EXTERNAL STATIC PRESSURE - In. w.g.																									
	0.1		0.2		0.3		0.4		0.5		0.6		0.7		0.8		0.9		1.0		1.1		1.2		1.3	
	RPM	BHP	RPM	BHP	RPM	BHP	RPM	BHP	RPM	BHP	RPM	BHP	RPM	BHP	RPM	BHP	RPM	BHP	RPM	BHP	RPM	BHP	RPM	BHP	RPM	BHP
2000	418	0.26	453	0.33	490	0.41	530	0.48	573	0.55	617	0.62	658	0.68	697	0.76	734	0.84	767	0.93	797	1.01	825	1.09	852	1.17
2200	430	0.34	465	0.42	502	0.49	543	0.56	586	0.63	630	0.70	671	0.78	709	0.86	745	0.95	778	1.04	807	1.12	835	1.21	863	1.29
2400	444	0.44	478	0.50	516	0.57	557	0.65	601	0.72	644	0.80	683	0.88	721	0.97	757	1.07	789	1.16	818	1.25	847	1.33	875	1.41
2600	458	0.53	493	0.60	530	0.67	572	0.74	616	0.82	658	0.91	697	1.00	734	1.09	769	1.19	801	1.29	830	1.38	859	1.46	888	1.55
2800	473	0.63	508	0.70	547	0.77	589	0.85	632	0.93	673	1.03	711	1.13	747	1.23	781	1.33	813	1.43	843	1.52	872	1.60	902	1.69
3000	489	0.74	525	0.81	564	0.89	607	0.97	649	1.06	688	1.16	725	1.27	761	1.38	795	1.48	826	1.58	857	1.66	887	1.75	918	1.84
3200	506	0.86	543	0.93	583	1.01	625	1.10	666	1.20	703	1.31	740	1.42	775	1.53	809	1.64	841	1.73	871	1.82	902	1.91	934	2.01
3400	525	0.99	563	1.07	603	1.15	644	1.24	682	1.36	719	1.48	755	1.59	790	1.70	824	1.80	856	1.90	887	1.99	919	2.08	951	2.18
3600	545	1.13	583	1.21	623	1.30	662	1.41	699	1.53	735	1.65	771	1.77	806	1.87	840	1.97	872	2.07	903	2.16	936	2.25	969	2.36
3800	566	1.28	604	1.36	643	1.46	679	1.58	715	1.71	752	1.84	788	1.95	823	2.06	856	2.16	889	2.25	921	2.34	954	2.43	987	2.54
4000	587	1.44	625	1.53	661	1.64	697	1.78	733	1.91	770	2.03	806	2.15	841	2.25	874	2.34	906	2.43	938	2.52	971	2.61	1005	2.71
4200	609	1.60	645	1.71	680	1.85	715	1.99	751	2.12	788	2.24	825	2.35	859	2.44	892	2.53	924	2.62	957	2.71	989	2.80	1023	2.89
4400	629	1.79	664	1.92	698	2.07	734	2.21	771	2.34	808	2.45	844	2.55	878	2.64	911	2.73	943	2.81	975	2.89	1008	2.98	1041	3.08
4600	650	2.00	683	2.15	717	2.30	753	2.44	791	2.56	829	2.66	864	2.76	897	2.84	930	2.92	962	3.00	994	3.08	1026	3.17	1060	3.26
4800	669	2.23	702	2.39	737	2.55	774	2.67	813	2.78	850	2.88	884	2.97	917	3.05	949	3.12	981	3.20	1013	3.28	1045	3.36	1079	3.45

NOTE - MSAV® (Multi-Stage Air Volume) drive is capable of 350 - 1050 rpm.



## BLOWER DATA

### MSAV® (MULTI-STAGE AIR VOLUME) BELT DRIVE KIT SPECIFICATIONS

Model No.	Nominal / Maximum - hp	Drive Kit Number	RPM Range
120	3	#3	660 - 900
		#4	865 - 1080
240	5	#4	520 - 685
		#5	685 - 865
	7.5	#7	770 - 965

### FACTORY INSTALLED OPTIONS/FIELD INSTALLED ACCESSORY AIR RESISTANCE - in. w.g.

Air Volume cfm	Humiditrol Dehumidification Coil	Economizer	Filters MERV 13
<b>036, 060 MODELS</b>			
800	0.00	0.04	0.05
1000	0.00	0.04	0.07
1200	0.01	0.04	0.07
1400	0.02	0.04	0.07
1600	0.03	0.04	0.07
1800	0.04	0.05	0.07
2000	0.04	0.05	0.08
<b>120 MODEL</b>			
2000	0.03	0.06	0.03
2500	0.04	0.11	0.05
3000	0.05	0.13	0.06
3500	0.06	0.15	0.07
4000	0.08	0.19	0.08
4500	0.10	0.22	0.09
5000	0.12	0.29	0.10
5500	0.14	0.34	0.12
6000	0.15	0.52	0.13
<b>240 MODEL</b>			
3000	0.02	0.00	0.00
3500	0.04	0.00	0.00
4000	0.04	0.00	0.00
4500	0.04	0.00	0.00
5000	0.04	0.00	0.00
5500	0.06	0.01	0.01
6000	0.06	0.01	0.02
6500	0.08	0.01	0.02
7000	0.08	0.02	0.03
7500	0.10	0.02	0.04
8000	0.10	0.02	0.04
8500	0.10	0.03	0.04
9000	0.12	0.04	0.04
9500	0.14	0.04	0.06

### POWER EXHAUST FANS STANDARD STATIC PERFORMANCE

120 Model		240 Model	
Return Air System Static Pressure	Air Volume Exhausted	Return Air System Static Pressure	Air Volume Exhausted
in. w.g.	cfm	in. w.g.	cfm
0.05	4085	0	10,200
0.10	3685	0.05	9700
0.15	3280	0.10	9200
0.20	2880	0.15	8600
0.25	2475	0.20	8100
---	---	0.25	7600
---	---	0.30	6900
---	---	0.35	6000
---	---	0.40	5000
---	---	0.45	4150

**ELECTRICAL DATA**

**DIRECT DRIVE | 3 - 5 TON**

Model No.		SCH036H4E			SCH060H4E		
<sup>1</sup> Voltage - 60hz		208/230V-3ph	460V-3ph	575V-3ph	208/230V-3ph	460V-3ph	575V-3ph
<b>Compressor</b>	Rated Load Amps	11.6	5.7	4	16.5	7.2	5.5
	Locked Rotor Amps	73	38	25.6	110	52	38.9
<b>Outdoor Fan Motor(s)</b>	Full Load Amps (total)	0.3 (0.6)	0.3 (0.6)	0.3 (0.6)	0.7 (1.4)	0.7 (1.4)	0.7 (1.4)
	<b>Service Outlet 115V GFI (Amps)</b>	20	20	20	20	20	20
<b>Indoor Blower Motor</b>	Horsepower	1.5	1.5	1.5	1.5	1.5	1.5
	Type	Direct (ECM)	Direct (ECM)	Direct (ECM)	Direct (ECM)	Direct (ECM)	Direct (ECM)
	Full Load Amps	4.4	2.3	2.3	4.4	2.3	2.3
<sup>2</sup> <b>Maximum Overcurrent Protection</b>	Unit Only	30	15	15	40	15	15
<sup>3</sup> <b>Minimum Circuit Ampacity</b>	Unit Only	20	11	9	27	13	11

**ELECTRICAL HEAT DATA**

Electric Heat Voltage			208V	240V	480V	575V	208V	240V	480V	575V
<sup>2</sup> <b>Maximum Overcurrent Protection</b>	Unit+ Electric Heat	<b>10 kW</b>	---	---	20	---	---	---	20	---
		<b>15 kW</b>	<sup>4</sup> 45	60	30	25	<sup>4</sup> 45	60	30	25
		<b>20 kW</b>	---	---	---	---	---	---	35	---
		<b>30 kW</b>	---	---	---	---	<sup>4</sup> 90	100	50	40
<sup>3</sup> <b>Minimum Circuit Ampacity</b>	Unit+ Electric Heat	<b>10 kW</b>	---	---	18	---	---	---	18	---
		<b>15 kW</b>	45	51	26	21	45	51	26	21
		<b>20 kW</b>	---	---	---	---	---	---	33	---
		<b>30 kW</b>	---	---	---	---	84	96	48	39

NOTE - All units have a minimum Short Circuit Current Rating (SCCR) of 5000 amps.

<sup>1</sup> NOTE - Extremes of operating range are plus and minus 10% of line voltage.

<sup>2</sup> HACR type breaker or fuse.

<sup>3</sup> Refer to National or Canadian Electrical Code manual to determine wire, fuse and disconnect size requirements.

<sup>4</sup> Factory installed circuit breaker not available.



**ELECTRICAL DATA**

**BELT DRIVE | 10 TON**

Model No.		SCH120H4M		
		208/230V-3ph	460V-3ph	575V-3ph
<sup>1</sup> Voltage - 60hz				
Compressor 1	Rated Load Amps	16	7.8	5.7
	Locked Rotor Amps	110	52	38.9
Compressor 2	Rated Load Amps	16	7.8	5.7
	Locked Rotor Amps	110	52	38.9
Outdoor Fan Motors (3)	Full Load Amps (total)	3 (6)	1.5 (3)	1.2 (2.4)
Power Exhaust (1) 0.5 HP	Full Load Amps	3	1.5	1.2
Service Outlet 115V GFI (Amps)		20	20	20
Indoor Blower Motor	Horsepower	3	3	3
	Type	Belt	Belt	Belt
	Full Load Amps	10.6	4.8	3.9
<sup>2</sup> Maximum Overcurrent Protection	Unit Only	60	30	20
	With (1) 0.5 HP Power Exhaust	70	30	25
<sup>3</sup> Minimum Circuit Ampacity	Unit Only	53	26	20
	With (1) 0.5 HP Power Exhaust	56	27	21

**ELECTRICAL HEAT DATA**

Electric Heat Voltage			208V	240V	480V	600V
<sup>2</sup> Maximum Overcurrent Protection	Unit+ Electric Heat	15 kW	60	60	30	25
		20 kW	---	---	40	---
		30 kW	<sup>4</sup> 100	110	60	45
		40 kW	---	---	70	---
		45 kW	150	150	80	60
		60 kW	<sup>4</sup> 150	175	80	70
<sup>3</sup> Minimum Circuit Ampacity	Unit+ Electric Heat	15 kW	53	59	29	23
		20 kW	---	---	37	---
		30 kW	92	104	52	41
		40 kW	---	---	67	---
		45 kW	131	149	74	60
		60 kW	139	158	79	63
<sup>2</sup> Maximum Overcurrent Protection	Unit+ Electric Heat and (1) 0.5 HP Power Exhaust	15 kW	70	70	35	25
		20 kW	---	---	40	---
		30 kW	<sup>4</sup> 100	110	60	45
		40 kW	---	---	70	---
		45 kW	<sup>4</sup> 150	175	80	70
		60 kW	<sup>4</sup> 150	175	90	70
<sup>3</sup> Minimum Circuit Ampacity	Unit+ Electric Heat and (1) 0.5 HP Power Exhaust	15 kW	57	63	31	25
		20 kW	---	---	38	---
		30 kW	96	108	53	43
		40 kW	---	---	69	---
		45 kW	135	153	76	61
		60 kW	143	162	81	65

NOTE - All units have a minimum Short Circuit Current Rating (SCCR) of 5000 amps.

<sup>1</sup> NOTE - Extremes of operating range are plus and minus 10% of line voltage.

<sup>2</sup> HACR type breaker or fuse.

<sup>3</sup> Refer to National or Canadian Electrical Code manual to determine wire, fuse and disconnect size requirements.

<sup>4</sup> Factory installed circuit breaker not available.

**ELECTRICAL DATA**

**BELT DRIVE | 20 TON**

Model No.		SCH240H4					
<sup>1</sup> Voltage - 60hz		208/230V-3ph		460V-3ph		575V-3ph	
Compressor 1	Rated Load Amps	16		7.8		5.7	
	Locked Rotor Amps	110		52		38.9	
Compressor 2	Rated Load Amps	16		7.8		5.7	
	Locked Rotor Amps	110		52		38.9	
Compressor 3	Rated Load Amps	16		7.8		5.7	
	Locked Rotor Amps	110		52		38.9	
Compressor 4	Rated Load Amps	16		7.8		5.7	
	Locked Rotor Amps	110		52		38.9	
Outdoor Fan Motors (6)	Full Load Amps	2.4		1.3		1	
	(total)	(14.4)		(7.8)		(6)	
Power Exhaust (3) 0.33 HP	Full Load Amps	2.4		1.3		1	
	(total)	(7.2)		(3.9)		(3)	
Service Outlet 115V GFI (Amps)		20		20		20	
Indoor Blower Motor	Horsepower	5	7.5	5	7.5	5	7.5
	Full Load Amps	16.7	24.2	7.6	11	6.1	9
<sup>2</sup> Maximum Overcurrent Protection	Unit Only	110	125	50	60	40	45
	With (3) 0.33 HP Power Exhaust	110	125	60	60	45	50
<sup>3</sup> Minimum Circuit Ampacity	Unit Only	100	109	49	53	37	41
	With (3) 0.33 HP Power Exhaust	107	116	53	57	40	44

**ELECTRICAL HEAT DATA**

Electric Heat Voltage			208V	240V	208V	240V	480V	480V	600V	600V
<sup>2</sup> Maximum Overcurrent Protection	Unit+ Electric Heat	20 kW	---	---	---	---	50	60	---	---
		30 kW	<sup>4</sup> 110	125	125	125	60	60	45	50
		40 kW	---	---	---	---	70	80	---	---
		60 kW	<sup>4</sup> 150	175	175	175	90	90	70	70
		80 kW	---	---	---	---	110	110	---	---
		90 kW	<sup>4</sup> 225	250	<sup>4</sup> 225	250	125	125	100	100
<sup>3</sup> Minimum Circuit Ampacity	Unit+ Electric Heat	20 kW	---	---	---	---	49	53	---	---
		30 kW	100	112	109	121	55	59	44	48
		40 kW	---	---	---	---	70	74	---	---
		60 kW	146	166	156	175	82	86	66	69
		80 kW	---	---	---	---	106	110	---	---
		90 kW	209	238	218	247	118	123	95	98
<sup>2</sup> Maximum Overcurrent Protection	Unit+ Electric Heat and (3) 0.33 HP Power Exhaust	20 kW	---	---	---	---	60	60	---	---
		30 kW	<sup>4</sup> 110	125	<sup>4</sup> 125	150	60	70	50	60
		40 kW	---	---	---	---	80	80	---	---
		60 kW	175	175	<sup>4</sup> 175	200	90	100	70	80
		80 kW	---	---	---	---	125	125	---	---
		90 kW	<sup>4</sup> 225	250	<sup>4</sup> 250	<sup>4</sup> 300	125	150	100	110
<sup>3</sup> Minimum Circuit Ampacity	Unit+ Electric Heat and (3) 0.33 HP Power Exhaust	20 kW	---	---	---	---	53	57	---	---
		30 kW	109	121	118	130	60	64	48	52
		40 kW	---	---	---	---	75	79	---	---
		60 kW	155	175	165	184	87	91	70	73
		80 kW	---	---	---	---	111	115	---	---
		90 kW	218	247	227	256	123	127	98	102

NOTE - All units have a minimum Short Circuit Current Rating (SCCR) of 5000 amps.

<sup>1</sup> NOTE - Extremes of operating range are plus and minus 10% of line voltage.

<sup>2</sup> HACR type breaker or fuse.

<sup>3</sup> Refer to National or Canadian Electrical Code manual to determine wire, fuse and disconnect size requirements.

<sup>4</sup> Factory installed circuit breaker not available.

## OUTDOOR SOUND DATA

Unit Model No.	Octave Band Sound Power Levels dBA, re 10 <sup>-12</sup> Watts Center Frequency - HZ							<sup>1</sup> Sound Rating Number dBA
	125	250	500	1000	2000	4000	8000	
036	55	59	63	61	57	48	39	67
060	65	71	74	72	69	63	54	78
120	80	79	79	76	71	65	57	89
240	94	91	90	87	83	79	72	92

Note - The octave sound power data does not include tonal corrections.

<sup>1</sup> Sound Rating Number according to AHRI Standard 270-95 or AHRI Standard 370-2001 (includes pure tone penalty). Sound Rating Number is the overall A-Weighted Sound Power Level, (LWA), dB (100 Hz to 10,000 Hz).

## UNIT CLEARANCES

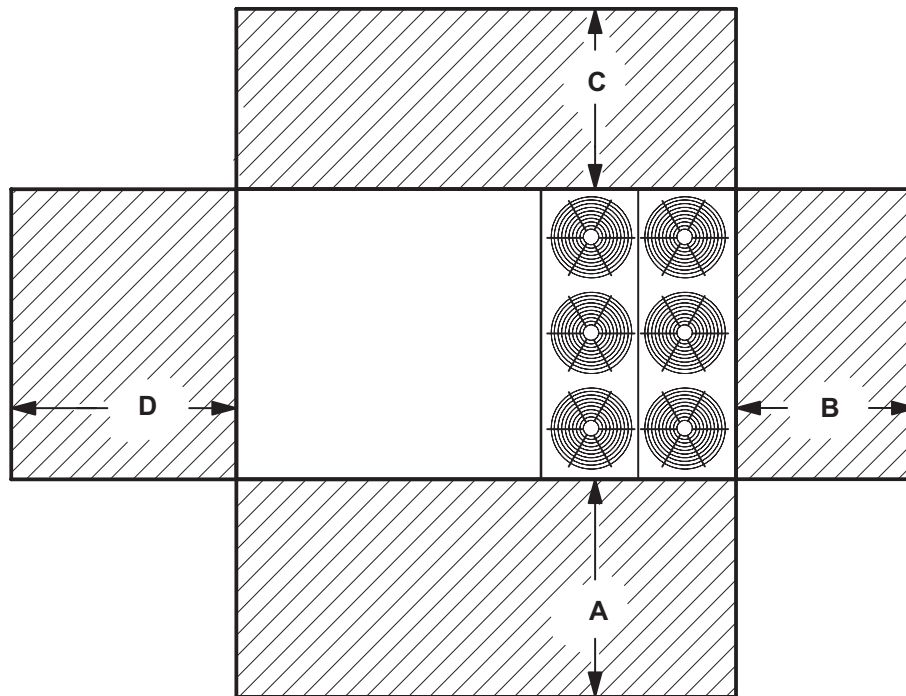

<sup>1</sup> Unit Clearance	A		B		C		D		Top Clearance	
	in.	mm	in.	mm	in.	mm	in.	mm		
<b>Service Clearance</b>	036, 060	48	1219	36	914	60	1524	60	1524	Unobstructed
	120	60	1524	36	914	60	1524	60	1524	Unobstructed
	240	72	1829	36	914	60	1524	96	2438	Unobstructed
<b>Minimum Operation Clearance</b>	All	36	914	36	914	36	914	36	914	Unobstructed

NOTE - Entire perimeter of unit base requires support when elevated above the mounting surface.

<sup>1</sup> Service Clearance - Required for removal of serviceable parts.

Minimum Operation Clearance - Required clearance for proper unit operation.

## WEIGHT DATA

Model Number	Net		Shipping	
	lbs.	kg	lbs.	kg
SCH036 Base Unit	833	378	933	423
SCH036 Max Unit	965	438	1065	483
SCH060 Base Unit	856	388	956	434
SCH060 Max Unit	995	451	1095	497
SCH120 Base Unit	1468	666	1568	711
SCH120 Max Unit	1699	771	1799	816
SCH240 Base Unit	2603	1181	2703	1226
SCH240 Max Unit	3074	1394	3174	1440

NOTE - Base Unit is NO OPTIONS.

NOTE - Max. Unit is the unit with ALL INTERNAL OPTIONS Installed. (Max Electric Heat, Economizer, Standard Static Power Exhaust Fans, Humiditrol, Controls, etc.). Does not include accessories EXTERNAL to unit.

## OPTIONS / ACCESSORIES

Description	Weight		
	lbs.	kg	
<b>CABINET</b>			
Combination Coil/Hail Guards	036 or 060	24	11
	120	25	11
	240	50	23
<b>ECONOMIZER / OUTDOOR AIR / EXHAUST</b>			
Economizer	036 or 060	50	23
	120	70	32
	240	138	63
Outdoor Air Dampers	240	68	31
Power Exhaust	120	28	13
	240	99	45
<b>ELECTRIC HEAT</b>			
Electric Heat	10 kW (036-060-120 models)	31	14
	15 kW (036-060-120 models)	31	14
	20 kW (060 and 120 models)	38	17
	30 kW (060-120 models)	38	17
	40 kW (120 models)	42	19
	45 kW (120 models)	42	19
	60 kW (120 models)	49	22
	20 kW (240 models)	59	27
	30 kW (240 models)	59	27
	40 kW (240 models)	76	34
	45 kW (240 models)	76	34
	60 kW (240 models)	76	34
	80 kW (240 models)	84	38
	90 kW (240 models)	84	38
<b>PACKAGING</b>			
LTL Packaging	036 or 060	90	41
(less than truck load)	120	105	48
	240	300	136
<b>ROOF CURBS</b>			
Hybrid Roof Curbs, Downflow 14 in. height	036 or 060	70	32
	120	80	36
	240	115	52
Hybrid Roof Curbs, Downflow 24 in. height	036 or 060	105	48
	120	120	54
	240	170	77
<b>HUMIDITROL® DEHUMIDIFICATION SYSTEM</b>			
Humiditrol Dehumidification Option (Net Weight)	036 or 060	27	12
	120	57	26
	240	100	45

**DIMENSIONS - UNIT**

**SCH036H | SCH060H**

**CORNER WEIGHTS**

**CENTER OF GRAVITY**

Model No.	AA		BB		CC		DD		EE		FF	
	lbs.	kg	lbs.	kg	lbs.	kg	lbs.	kg	in.	mm	in.	mm
SCH036H Base Unit	150	68	210	95	276	125	198	90	35-3/4	908	30-7/8	784
SCH036H Max. Unit	166	75	251	114	330	150	218	99	35-3/4	908	31-7/8	810
SCH060H Base Unit	150	68	209	95	289	131	207	94	34-3/4	883	30-7/8	784
SCH060H Max. Unit	167	76	251	114	347	157	230	104	34-3/4	883	31-7/8	810

Max. Unit - The Base Unit with ALL OPTIONS Installed. (Economizer and controls)

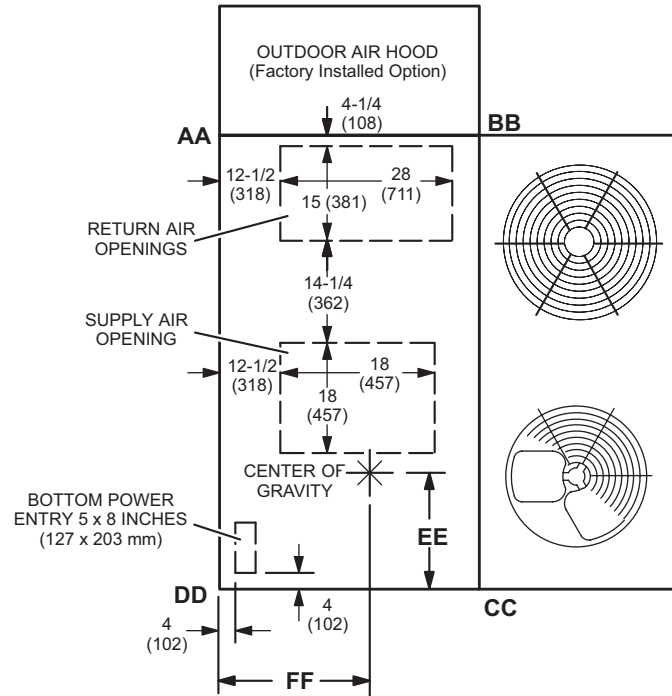

**TOP VIEW**

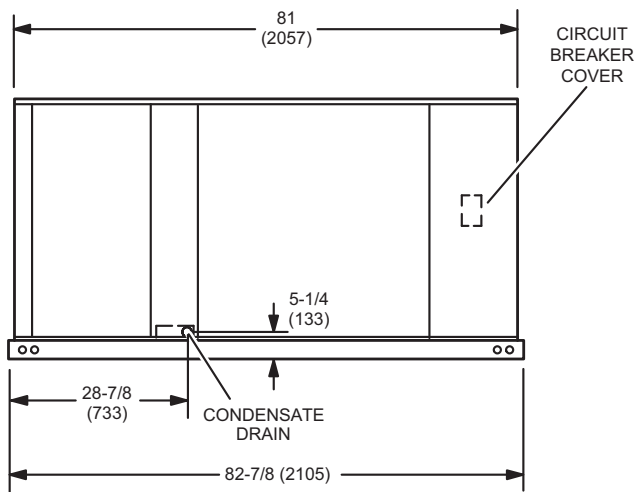

**SIDE VIEW**

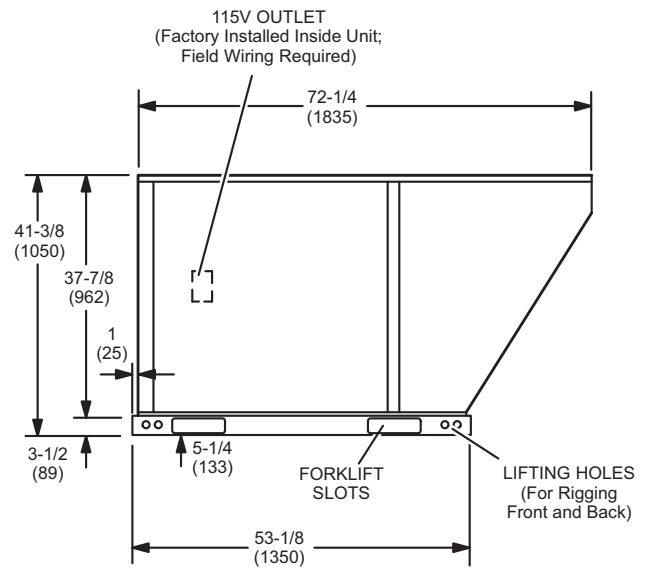

**FRONT VIEW**

**DIMENSIONS - UNIT**

**SCH120H**

**CORNER WEIGHTS**

**CENTER OF GRAVITY**

Model No.	AA		BB		CC		DD		EE		FF	
	lbs.	kg	lbs.	kg	lbs.	kg	lbs.	kg	in.	mm	in.	mm
SCH120H Base Unit	395	179	296	134	332	151	444	201	42-1/2	1080	37	940
SCH120H Max. Unit	467	212	350	159	393	178	525	238	42-1/2	1080	37	940

Max. Unit - The Base Unit with ALL OPTIONS Installed. (Economizer and controls)

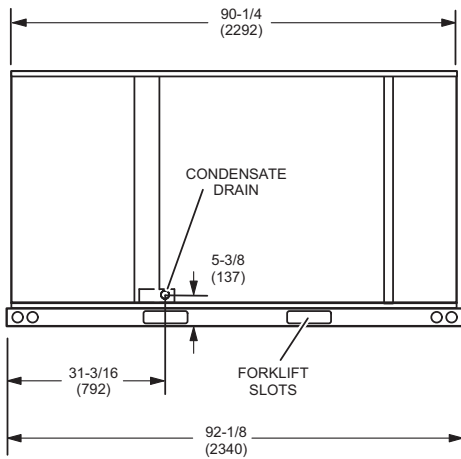
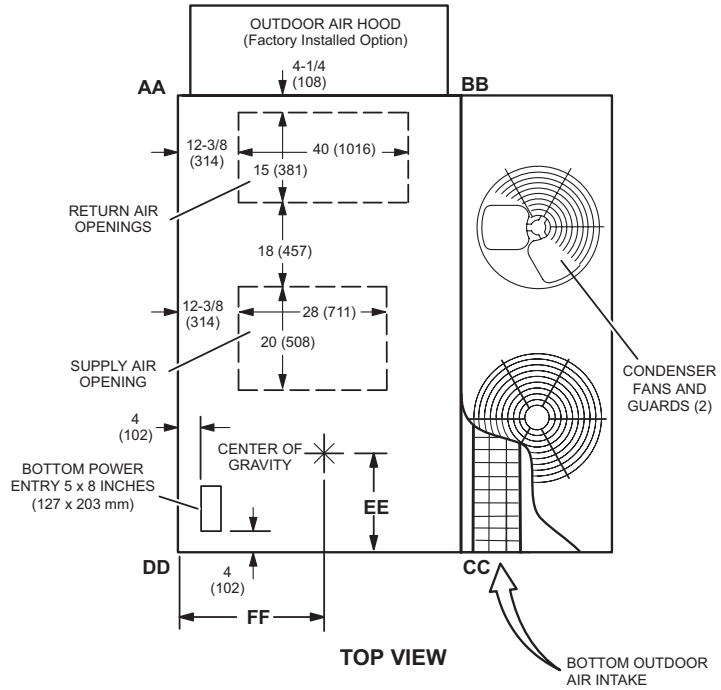

**SIDE VIEW**

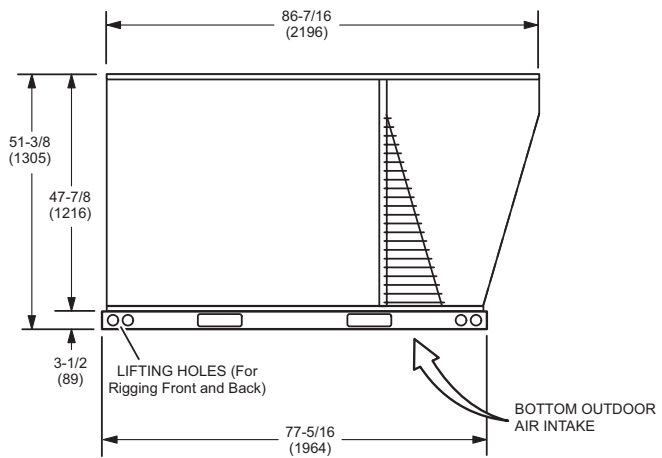

**FRONT VIEW**

**DIMENSIONS - UNIT**

**SCH240H**

CORNER WEIGHTS									CENTER OF GRAVITY			
Model No.	AA		BB		CC		DD		EE		FF	
	lbs.	kg	lbs.	kg	lbs.	kg	lbs.	kg	in.	mm	in.	mm
SCH240H Base Unit	533	242	551	250	772	350	747	339	38-1/8	968	61-1/4	1556
SCH240H Max. Unit	630	286	651	295	911	413	882	400	38-1/8	968	61-1/4	1556

Max. Unit - The Base Unit with ALL OPTIONS Installed. (Economizer and controls)

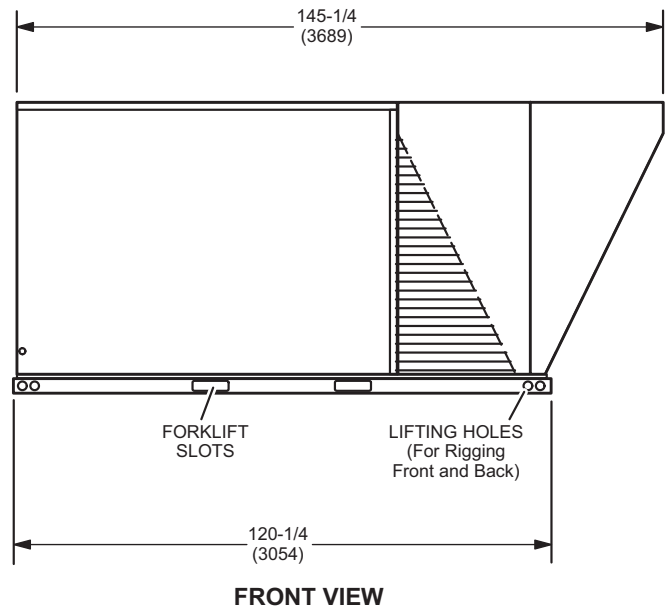
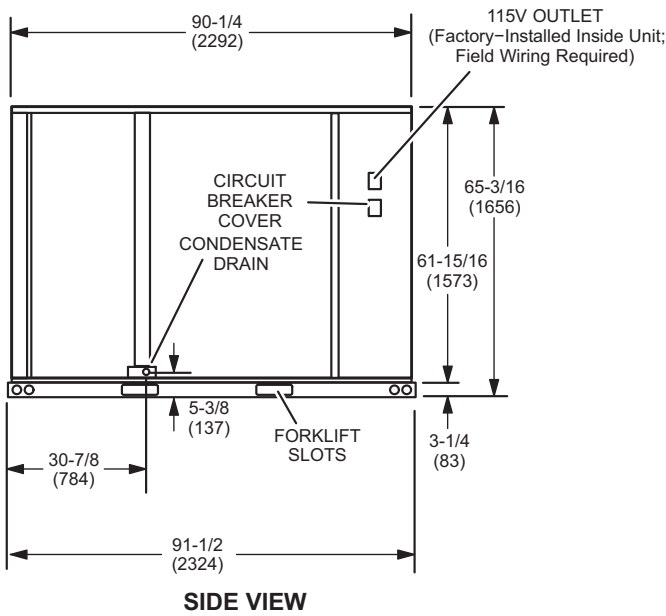
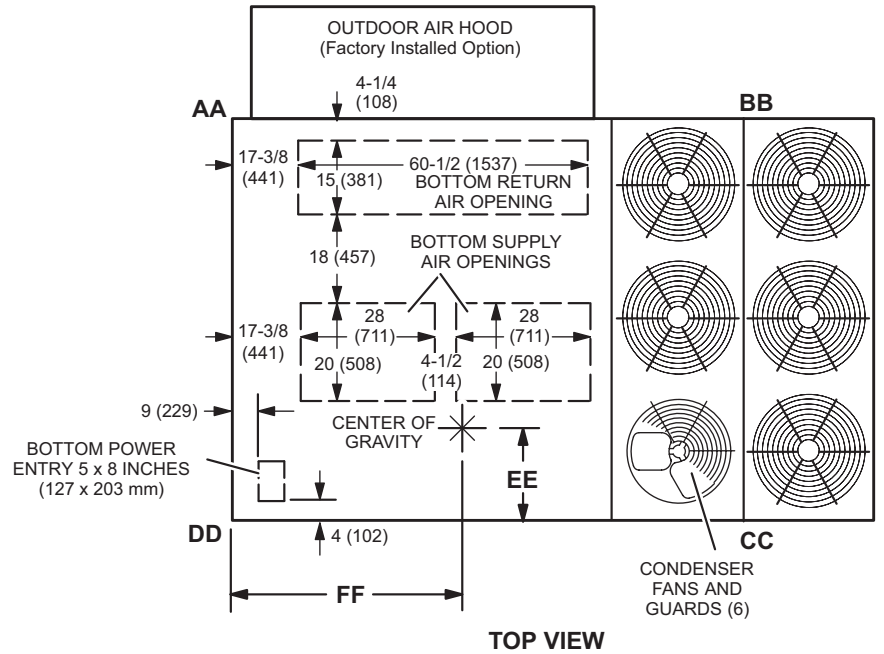



**OPTIONAL OUTDOOR AIR HOOD DETAIL  
036 or 060 Models**

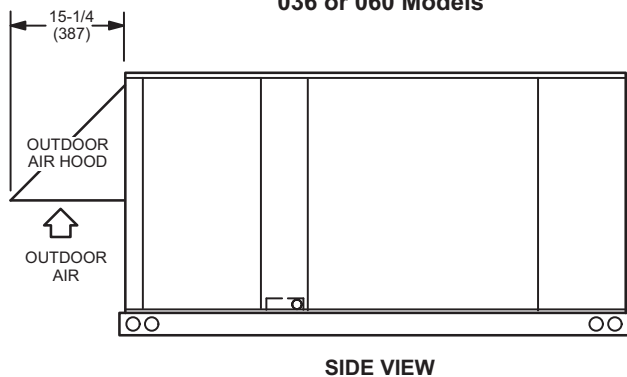

**OPTIONAL OUTDOOR AIR HOOD DETAIL  
OPTIONAL POWER EXHAUST DETAIL  
120H Models**

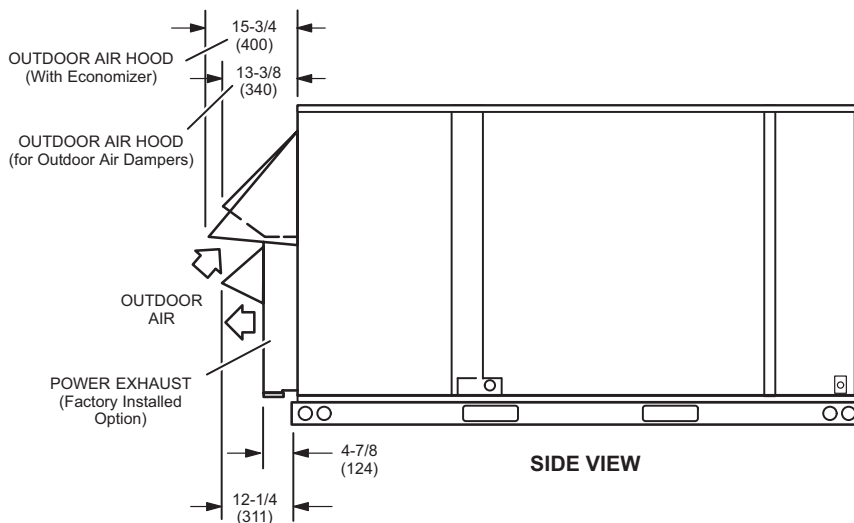

**OPTIONAL OUTDOOR AIR HOOD DETAIL  
240H Models**

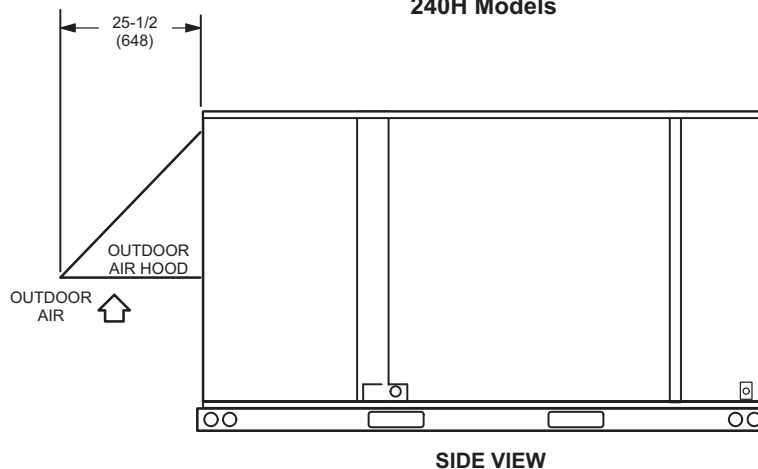

# DIMENSIONS - ACCESSORIES

## HYBRID ROOF CURBS - 036-060 MODELS - DOUBLE DUCT OPENING

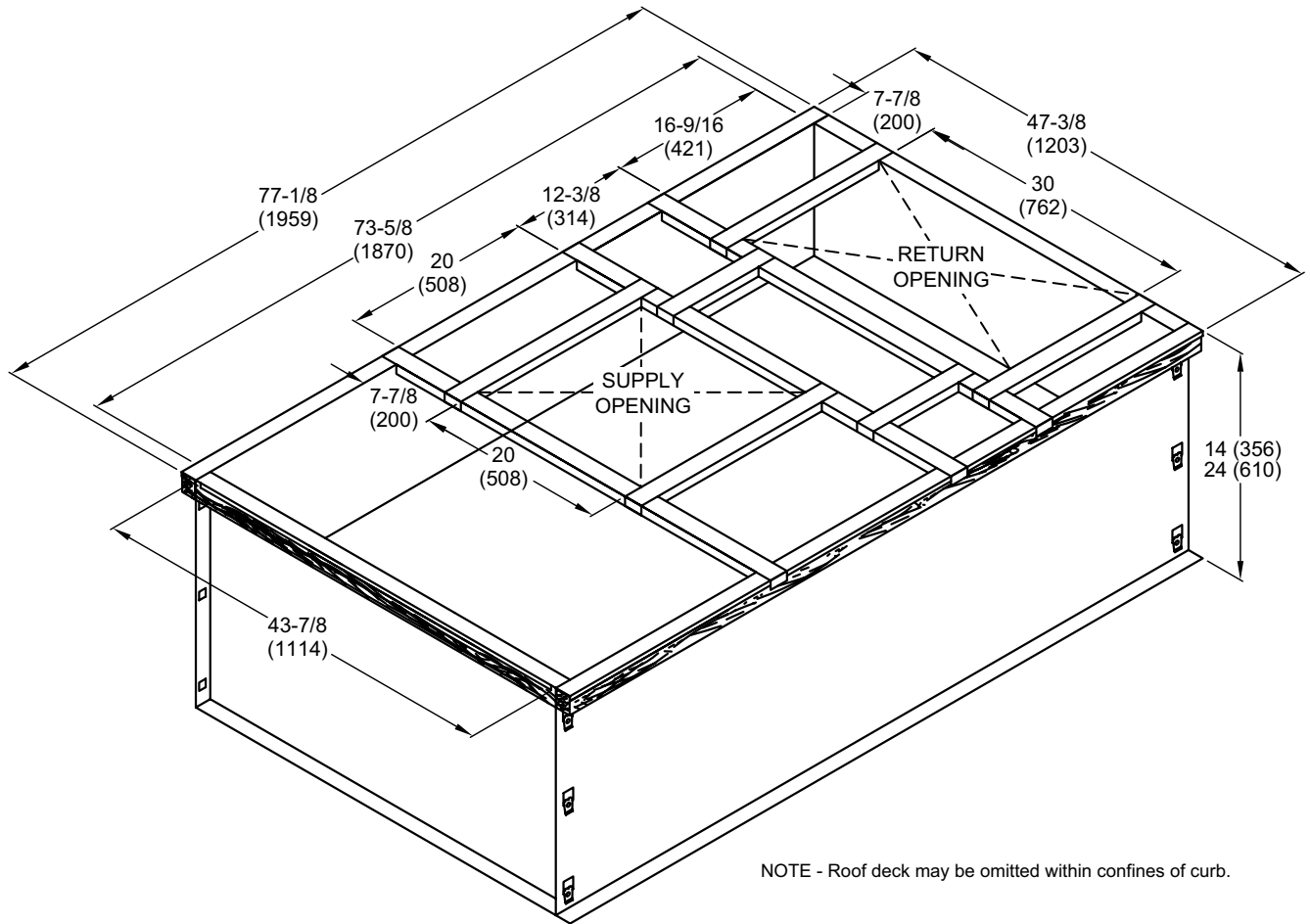

**TYPICAL FLASHING DETAIL FOR ROOF CURB**

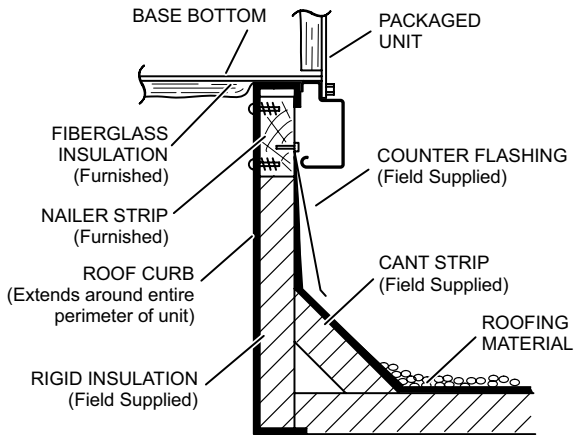

**DETAIL ROOF CURB**

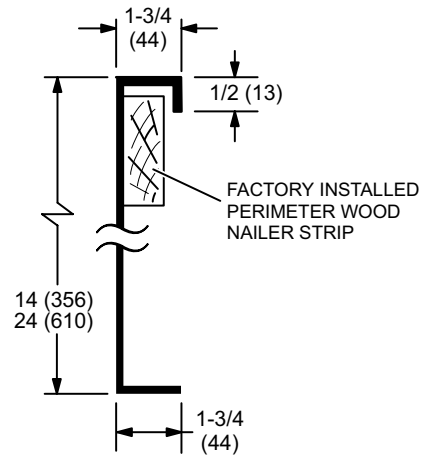

# DIMENSIONS - ACCESSORIES

## HYBRID ROOF CURBS - 120 MODEL - DOUBLE DUCT OPENING

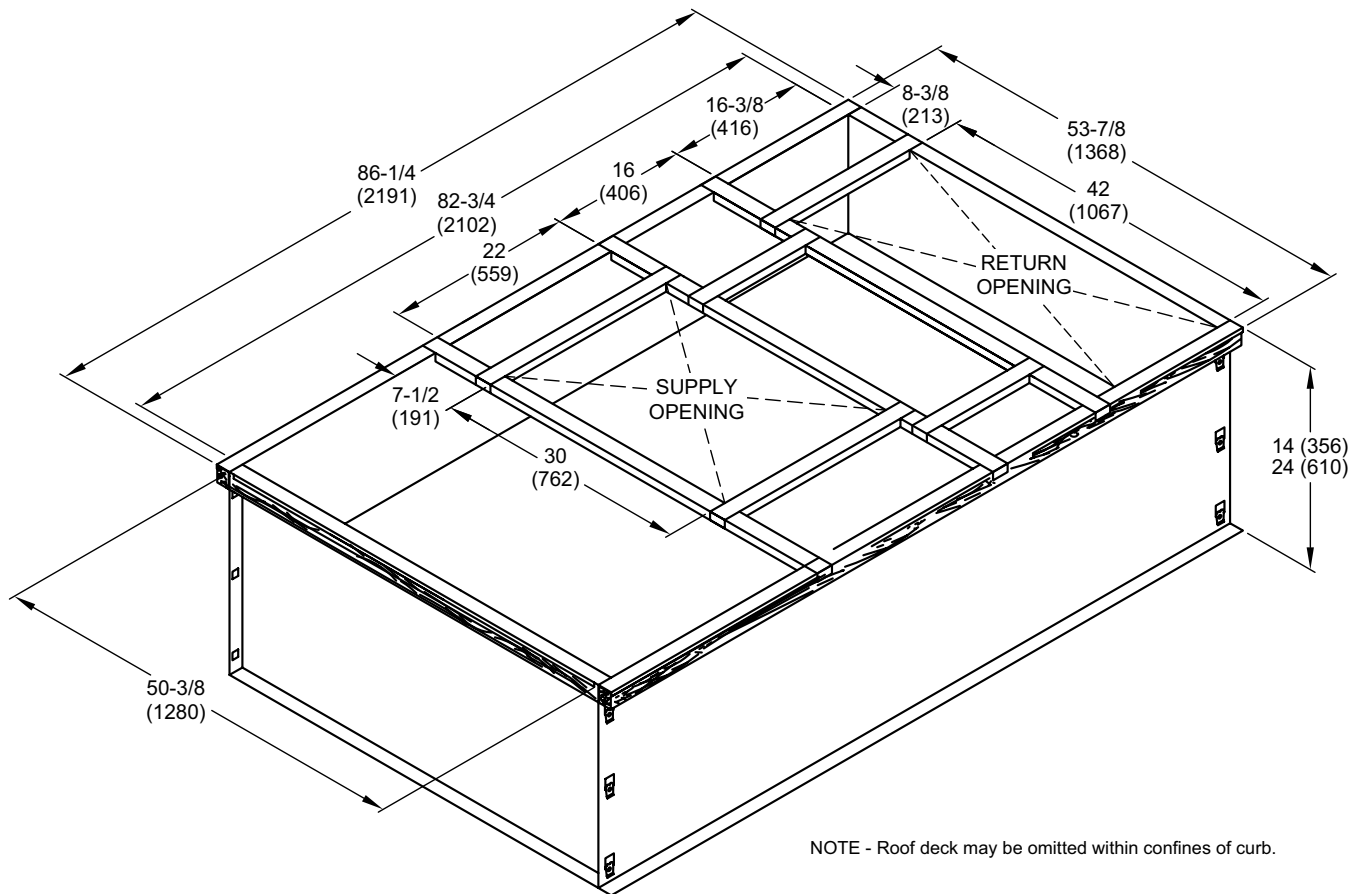

**TYPICAL FLASHING DETAIL FOR ROOF CURB**

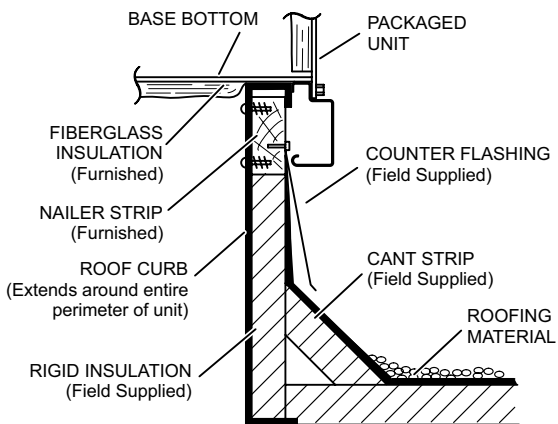

**DETAIL ROOF CURB**

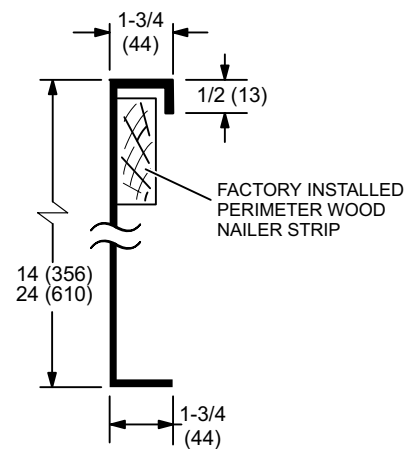

# DIMENSIONS - ACCESSORIES

## HYBRID ROOF CURBS - 240 MODEL - FULL PERIMETER - DOUBLE DUCT OPENING

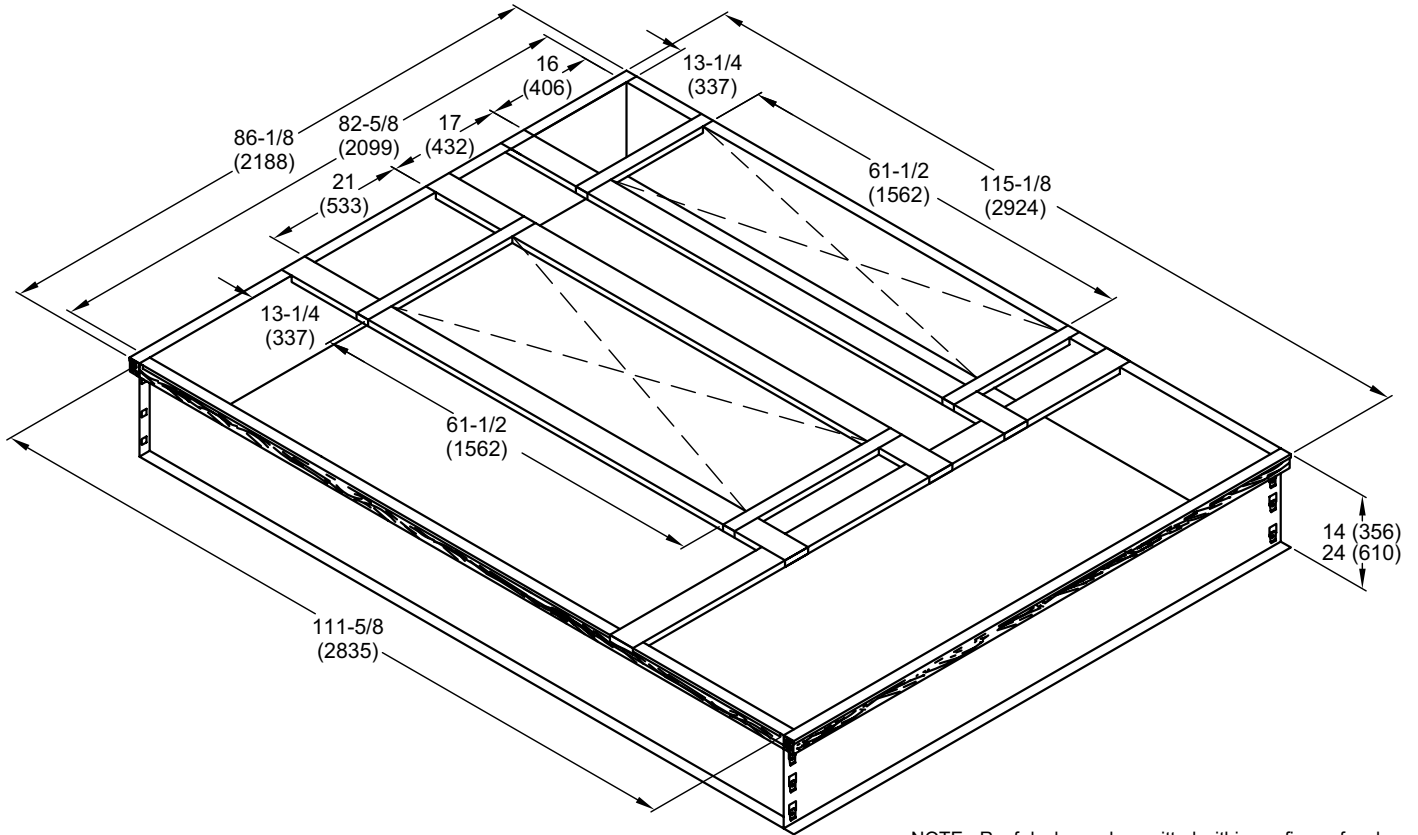

NOTE - Roof deck may be omitted within confines of curb.

### TYPICAL FLASHING DETAIL FOR ROOF CURB

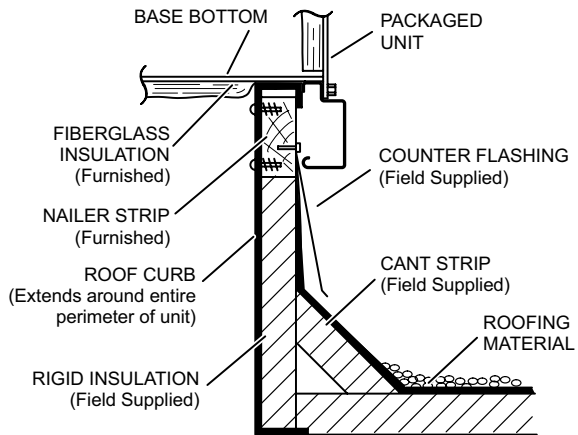

### DETAIL ROOF CURB

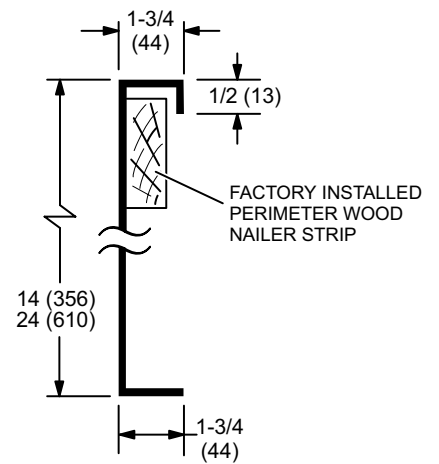



**Intertek**

Visit us at [www.lennox.com](http://www.lennox.com)

For the latest technical information, [www.lennoxcommercial.com](http://www.lennoxcommercial.com)

Contact us at 1-800-4-LENNOX



NOTE - Due to Lennox' ongoing commitment to quality, Specifications, Ratings and Dimensions subject to change without notice and without incurring liability. Improper installation, adjustment, alteration, service or maintenance can cause property damage or personal injury. Installation and service must be performed by a qualified installer and servicing agency.

©2019 Lennox Industries, Inc.