

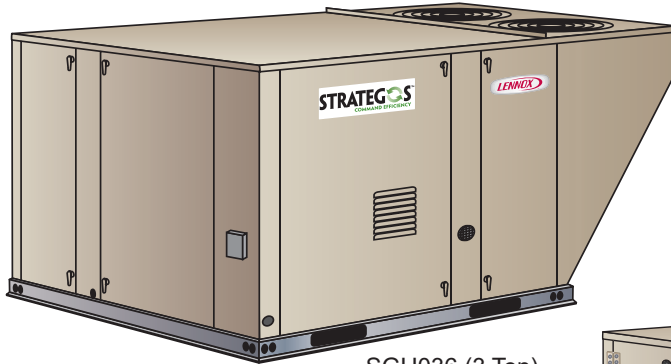

COMMERCIAL
PRODUCT SPECIFICATIONS

Bulletin No. 210903
March 2020
Supersedes January 2020



SGH036 (3 Ton)
SGH060 (5 Ton)

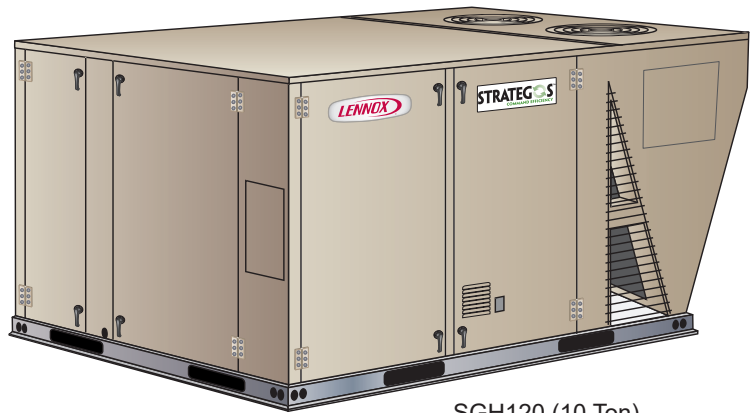

SGH120 (10 Ton)

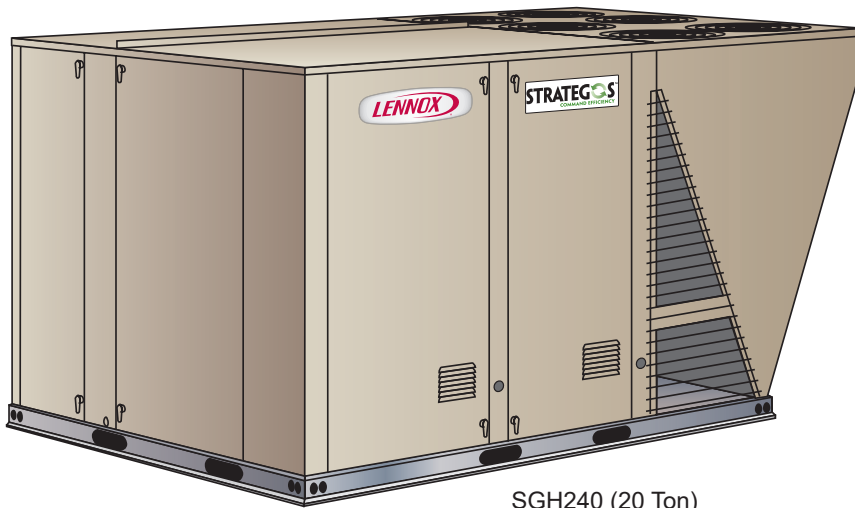

SGH240 (20 Ton)



3 to 20 Tons
Net Cooling Capacity - 36,000 to 232,000 Btuh
Gas Input Heat Capacity - 70,000 to 480,000 Btuh

MODEL NUMBER IDENTIFICATION

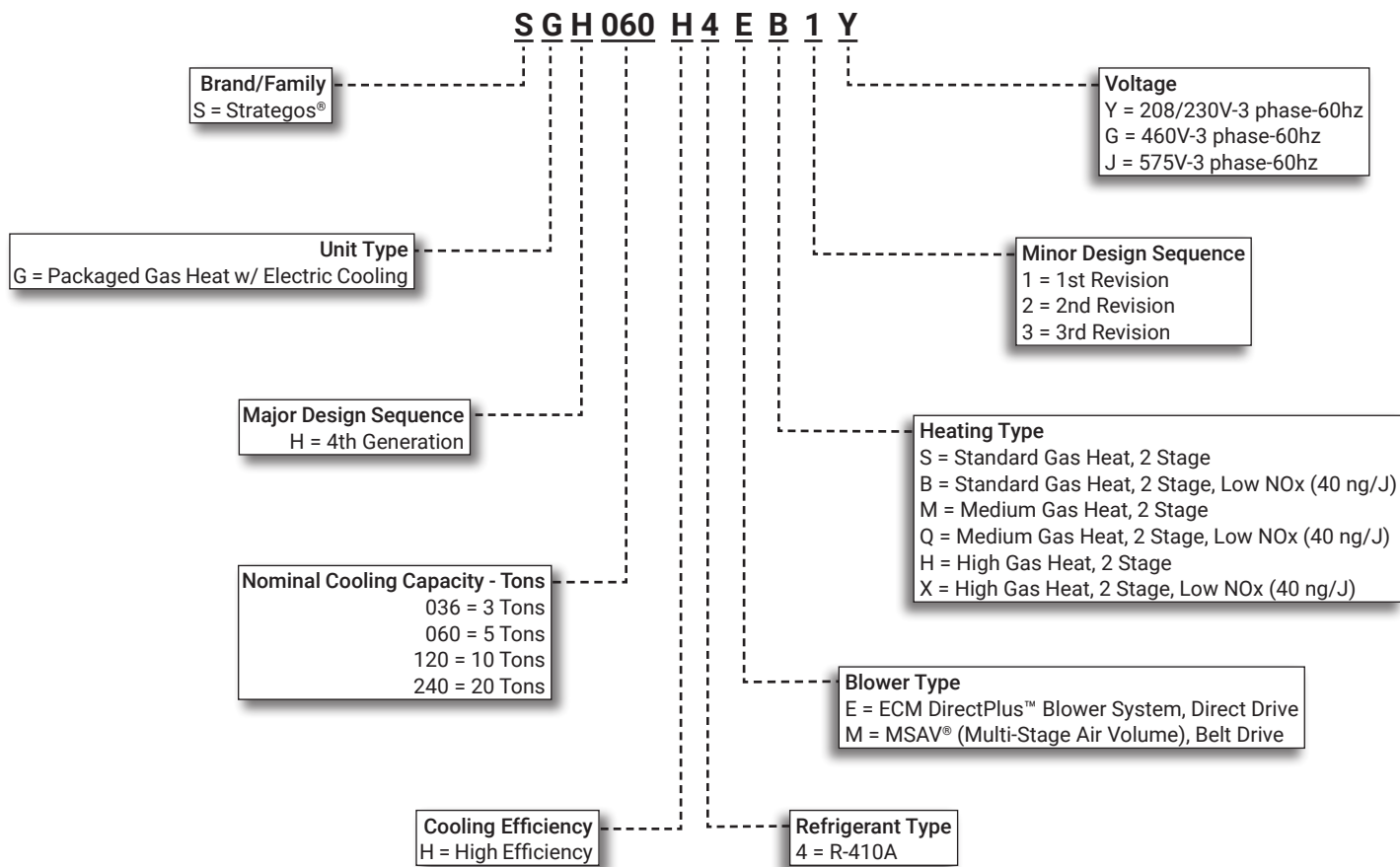

CONTENTS

Approvals and Warranty	4
Blower Data	35
Control System	9
Dimensions - Accessories	46
Dimensions - Unit	43
Electrical Data	39
Features And Benefits	4
High Altitude Derate	28
Humiditrol® Dehumidification System Option	12
Humiditrol® Dehumidification System Ratings	33
Options / Accessories	23
Outdoor Sound Data	41
Ratings	30
Sequence Of Operation	16
Specifications	26
Specifications - Gas Heat	28
Unit Clearances	41
Weight Data	42

FEATURE HIGHLIGHTS

Lennox' Strategos® packaged rooftop unit product line was created to save energy with intelligence by offering some of the highest energy efficiency ratings available with a powerful, easy to use unit controller. This makes Strategos® rooftop units perfect for business owners looking for an HVAC product with the lowest total cost of ownership

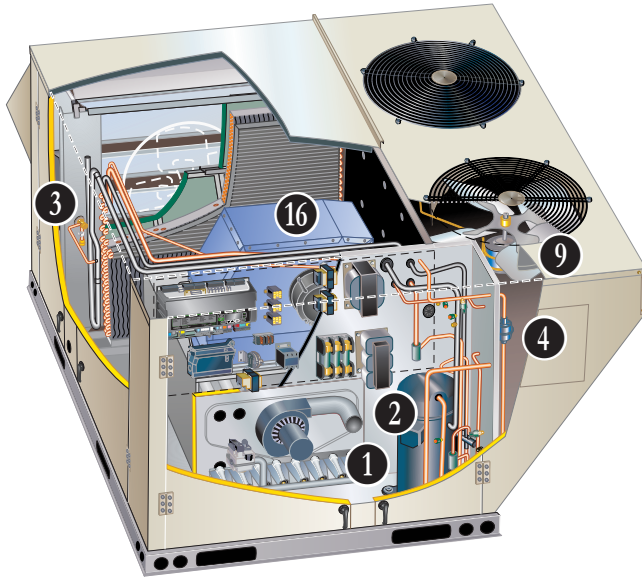

SGH036 (3 Ton)
SGH060 (5 Ton)

1. Heat Exchanger
2. Scroll Compressor
3. Thermal Expansion Valve
4. Filter/Drier
5. High Pressure Switch
6. Low Pressure Switch
7. Lennox' Environ™ Coil System
8. Evaporator Coil

9. Variable Speed ECM Outdoor Coil Fan Motors (3-5 Ton)
10. Outdoor Coil Fan Motors (10-20 Ton)
11. Heavy Gauge Steel Cabinet Panels
12. Power Entry
13. Fully Insulated
14. Hinged Access Panels
15. Grill Guards
16. DirectPlus™ Direct Drive ECM Blower (3-5 Ton)

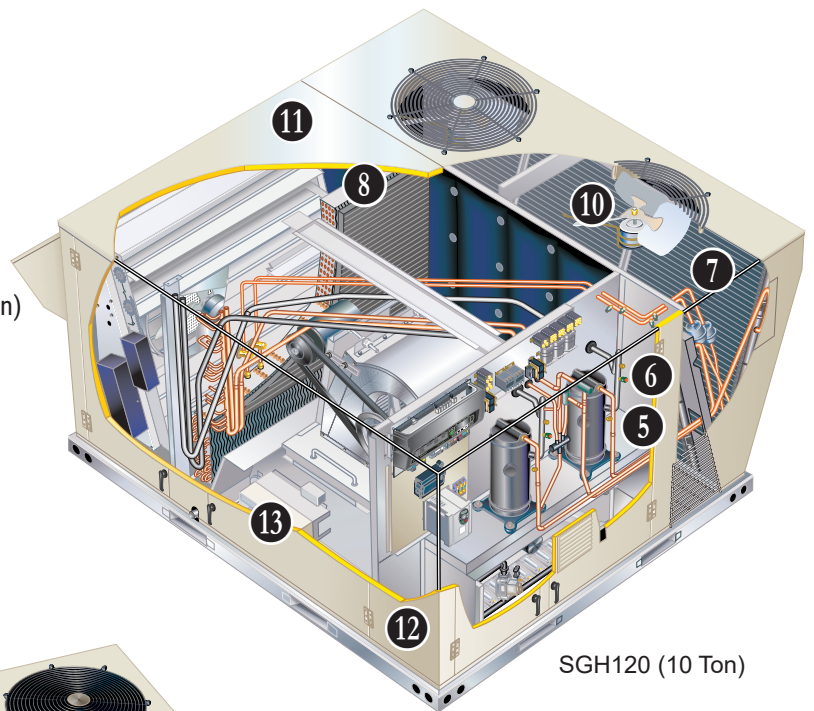

SGH120 (10 Ton)

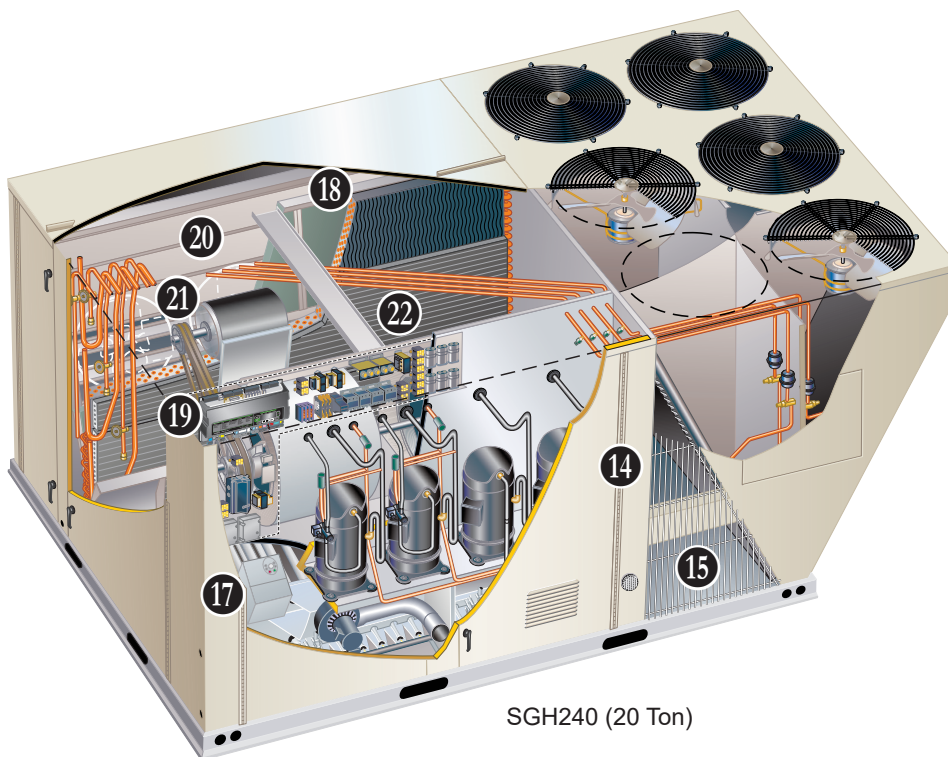

SGH240 (20 Ton)

17. MSAV® (Multi-Stage Air Volume) Belt Drive Blower (10-20 Ton)
18. Air Filters
19. Prodigy® 2.0 Unit Controller
20. Economizer (option)
21. Power Exhaust Fans (option)
22. Humiditrol® Dehumidification (option)

APPROVALS AND WARRANTY

APPROVALS

- AHRI Standard 210/240 certified (3 and 5 ton models)
- AHRI Standard 340/360 certified (10 and 20 ton models)
- ETL and CSA listed
- Unit and components ETL, NEC and CEC bonded for grounding to meet safety standards for servicing
- ENERGY STAR® certified

WARRANTY

- Aluminized heat exchanger - Limited ten years
- Stainless steel heat exchanger (optional) - Limited fifteen years
- Compressors - Limited five years
- Lennox' Environ™ Coil System - Limited three years
- Prodigy® 2.0 Unit Controller - Limited three years
- Optional High Performance Economizers - Limited five years
- All other covered components - Limited one year

FEATURES AND BENEFITS

HEATING SYSTEM

- Aluminized steel inshot burners
- Direct spark ignition
- Electronic flame sensor
- Combustion air inducer
- Redundant automatic single or dual stage gas valve with manual shut-off

1 Heat Exchanger

- Patented dimple-design
- Tubular construction
- Aluminized steel
- Life-cycle tested

NOTE - Optional Stainless Steel Heat Exchanger is required if mixed air temperature is below 45°F.

Limit Controls

- Fixed temperature setting
- Protect heat exchanger and other components from overheating

Safety Switches

- Flame roll-out switch
- Flame sensor
- Combustion air inducer proving switch
- Protects system operation

NOTE - All safety switches are monitored by the unit controller and any diagnostic codes are reported and recorded.

Required Selections

NOTE - All gas heating for 036-060 models is only available as Low NOx (40 ng/J).

Gas Input Choice - Order one:

3 ton models

- Standard Gas Heat (2 Stage, Low NOX/40 ng/J)
53,000/70,000 Btuh
- Medium Gas Heat (2 Stage, Low NOX/40 ng/J)
81,000/108,000 Btuh

5 ton models

- Standard Gas Heat (2 Stage, Low NOX/40 ng/J)
53,000/70,000 Btuh
- Medium Gas Heat (2 Stage, Low NOX/40 ng/J)
81,000/108,000 Btuh
- High Gas Heat (2 Stage, Low NOX/40 ng/J)
113,000/150,000 Btuh

10 ton models

- Standard Gas Heat (2 Stage)
84,500/130,000 Btuh
- Medium Gas Heat (2 Stage)
117,000/180,000 Btuh
- High Gas Heat (2 Stage)
156,000/240,000 Btuh

20 ton model

- Standard Gas Heat (2 Stage)
169,000/260,000 Btuh
- Medium Gas Heat (2 Stage)
234,000/360,000 Btuh
- High Gas Heat (2 Stage)
312,000/480,000 Btuh

NOTE - Natural gas values shown above.

FEATURES AND BENEFITS

HEATING SYSTEM (continued)

Options/Accessories

Factory Installed

Stainless Steel Heat Exchanger

- Required if mixed air temperature is below 45°F

Low Temperature Vestibule Heater

- Electric heater automatically controls minimum temperature in gas burner compartment when temperature is below -40°F
- CSA certified to allow operation of unit down to -60°F

Field Installed

Combustion Air Intake Extensions

- Recommended for use with existing flue extension kits in areas where high snow drifts can block intake air

Fresh Air Tempering

- Provides heating and cooling as needed to maintain the supply air temperature within a comfort range, regardless of the thermostat demand

NOTE - Requires field installed sensor kit and unit controller parameter change in the field to activate this mode of operation

LPG/Propane Kit

- Conversion kit to field change over units from Natural Gas to LPG/Propane

Vertical Vent Extension Kit

- Exhausts flue gases vertically above unit

COOLING SYSTEM

- Designed to maximize sensible and latent cooling performance at design conditions
- System operation from 0°F to 125°F without additional controls

2 Scroll Compressors

- Two-stage (3 to 5 ton) for increased part load efficiency
- Single speed (10 and 20 ton models)
- Resiliently mounted on rubber grommets
- Quiet operation

Compressor Crankcase Heater

- Protects against refrigerant migration that can occur during low ambient operation

3 Thermal Expansion Valve (TXV)

- Assures optimal performance throughout the application range
- Removable element head

4 Filter/Drier

- Solid core, molecular-sieve, high capacity filter/drier

5 High Pressure Switch

- Protects the system from high pressure conditions
- Automatic reset

6 Low Pressure Switch

- Shuts off unit if suction pressure falls below setting
- Loss of charge and freeze-up protection
- Automatic reset

Freezestat

- Cycles compressor off when suction line temperature falls below setpoint
- Protects evaporator coil

Low Ambient Pressure Switches

- Cycles condenser fan motors based on liquid line pressure
- Enables cooling operation down to 0°F outdoor air temperature

7 Lennox' Environ™ Coil System

- Condenser coil features lightweight, all aluminum brazed fin construction
- Constructed of three components
 - A flat extrusion tube
 - Fins in-between the flat extrusion tube
 - Two refrigerant manifolds

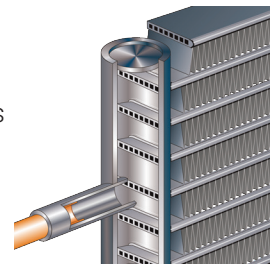

Environ™ Coil System Features:

- Improved heat transfer performance due to high primary surface area (flat tubes) versus secondary surface (fins)
- Smaller internal volume (reduced refrigerant charge)
- High durability
- All aluminum construction
- Fewer brazed joints
- Compact design
- Reduced unit weight
- Easy maintenance/cleaning
- Face split design
- Mounting brackets with rubber inserts
- Angled cabinet design protects coil from damage

8 Evaporator Coil

- Copper tube construction
- Enhanced rippled-edge aluminum fins
- Flared shoulder tubing connections
- Silver soldered construction for improved heat transfer
- Factory leak tested
- Row split coils on multi-stage air volume models
- Cross row circuiting with rifled copper tubing optimizes both sensible and latent cooling capacity

Condensate Drain Pan

- Plastic pan, sloped to meet drainage requirements of ASHRAE 62.1
- Drain connection extends outside unit

FEATURES AND BENEFITS

COOLING SYSTEM (continued)

9 Variable-Speed ECM Outdoor Coil Fan Motors (036-060 Only)

- Fan speed is controlled by the Prodigy® 2.0 unit controller
- Thermal overload protected
- Totally enclosed
- Permanently lubricated ball bearings
- Shaft up
- Wire basket mount

10 Outdoor Coil Fan Motors (120/240 Only)

- Permanent split capacitor
- Thermal overload protected
- Totally enclosed
- Permanently lubricated ball bearings
- Shaft up
- Wire basket mount

Outdoor Coil Fan

- PVC coated fan guard

R-410A Refrigerant

- Non-chlorine
- Ozone friendly
- Unit is factory pre-charged

Required Selections

Cooling Capacity

- Specify nominal cooling capacity of the unit

Options/Accessories

Factory Installed

Condensate Drain Trap

- EPDM high density rubber material

Factory or Field Installed

Drain Pan Overflow Switch

- Monitors condensate level in drain pan
- Shuts down unit if drain becomes clogged

CABINET

11 Construction

- Heavy-gauge steel panels
- Full perimeter heavy-gauge galvanized steel base rail (provides structural integrity for transportation, handling, and installation)
- Base rails have rigging holes
- Fork slots (two sides on the 3 and 5 ton models, three sides on the 10 and 20 ton models)
- Raised edges around duct and power entry openings in the bottom of the unit for water protection

Airflow

- Units are shipped in downflow (vertical) configuration

12 Power Entry

- Electrical lines can be brought through the unit base or through horizontal access knock-outs

Exterior Panels

- Constructed of heavy-gauge, galvanized steel
- Two-layer enamel paint finish

13 Insulation

- Fully insulated with non-hygroscopic fiberglass insulation (conditioned areas)
- Unit base is fully insulated
- Base insulation serves as an air seal to the roof curb, eliminating the need to add a seal during installation

14 Hinged Access Panels

- Economizer/filter section
- Blower section
- Compressor/controls/heat section
- Hinges are constructed of galvanized-steel
- Panel seals and quarter-turn latching handles provide a tight air and water seal

15 Grille Guards

- Protects space between outdoor coils and main cabinet

Options/Accessories

Factory Installed

Corrosion Protection

- Completely flexible immersed coating
- Electrodeposited dry film process
- AST ElectroFin E-Coat
- Meets Mil Spec MIL-P-53084, ASTM B117 Standard Method Salt Spray Testing

Option 1:

- Coated indoor and outdoor coil assemblies (including tube sheets)
- Painted cabinet interior

Option 2:

- Coated outdoor coil assembly (including tube sheets)

Factory or Field Installed

Combination Coil/Hail Guards

- Heavy gauge steel frame
- Painted to match cabinet
- Expanded metal mesh protects outdoor coil

FEATURES AND BENEFITS

BLOWER

16 DirectPlus™ Direct Drive ECM Blower System (036-060 Models Only)

- High-efficiency, variable-speed ECM (electronically commutated) motor
- Aerodynamically optimized impeller
- Backward curved blades mounted directly onto the rotor
- Combines the motor and electronics into one unit
- Eliminates the need for a variable-frequency drive
- Ramps the blower up or down to meet comfort needs
- Blower assembly slides out of unit for servicing



- Air inlet grill reduces indoor sound levels without affecting air performance

17 MSAV® (Multi-Stage Air Volume) Belt Drive Blower System (120-240 Models Only)

- Supply air variable frequency drive (VFD)
- Stages the amount of supply blower airflow according to compressor stages, heating demand, ventilation demand or smoke alarm
- Alters frequency and voltage of the power supply to the blower to control speed
- The amount of airflow for each stage can be set according to a parameter in the Prodigy 2.0 unit controller
- Unit is shipped from the factory with preset airflow
- The VFD has an operational range of 0 to 125°F outdoor air ambient temperature
- Lower operating costs are obtained when the blower is operated on lower speeds
- Overload protected
- Equipped with ball bearings
- All blower motors 5 hp and above meet minimum energy efficiency standards in accordance with the Energy Independence and Security Act (EISA) of 2007
- Forward curved blades
- Double inlet
- Blower wheel is statically and dynamically balanced
- Equipped with ball bearings
- Adjustable pulley (allows speed change during commissioning).
- Blower assembly slides out of unit for servicing

Blower Proving Switch

- Monitors blower operation, shuts down unit if blower fails

Required Selections

Blower Motor Choice (240 only)

- Specify when ordering base unit

Electronic Bypass Control (120-240 Models Only)

- Manual (default) or automatic electronic bypass VFD control
- In case of VFD malfunction, a VFD alarm is generated by the Prodigy® 2.0 unit controller
- VFD can be manually bypassed to continue unit operation at full blower speed. Or the unit controller can be set to automatically switch to full blower speed if a VFD alarm is generated

FEATURES AND BENEFITS

ELECTRICAL

SmartWire™ System

- Advanced wiring connectors
- Keyed and color-coded to prevent miswiring
- Wire coloring scheme is standardized across all models
- Each connection is intuitively labeled to make troubleshooting and servicing quick and easy

Circuit Breakers

- HACR type
- For overload and short circuit protection
- Factory wired
- Current sensitive and temperature activated
- Manual reset
- Mounted in the power entry panel

Electrical Plugs

- Positive connection electrical plugs connect common accessories and maintenance parts for easy removal or installation

Required Selections

Voltage Choice

- Specify when ordering base unit

Options/Accessories

Factory Installed

Short-Circuit Current Rating (SCCR) (240 models only)

- Higher short circuit protection up to 100kA

Factory or Field Installed

GFI Service Outlets (2)

- 115V ground fault circuit interrupter (GFCI) type
- Non-powered
- Field-wired (all models)
- Factory-wired and powered (240 model only)

Field Installed

GFI Weatherproof Cover

- Single-gang cover
- Heavy-duty UV-resistant polycarbonate case construction
- Hinged base cover with gasket

INDOOR AIR QUALITY

18 Air Filters

- MERV 8 (Minimum Efficiency Reporting Value) based on ASHRAE 52.2 efficiency
- Disposable
- 2 inch pleated

Options/Accessories

Field Installed

Healthy Climate® MERV 13 High Efficiency Air Filters

- MERV 13 (Minimum Efficiency Reporting Value) based on ASHRAE 52.2 efficiency
- Disposable
- 2 inch pleated

Indoor Air Quality (CO₂) Sensor

- Monitors CO₂ levels and reports to unit controller which adjusts economizer dampers as needed
- MSAV (multi-stage air volume) units with an economizer require a CO₂ sensor to modulate the economizer damper and maintain the desired minimum amount of fresh outdoor air
- CO₂ sensor can be installed in either the occupied zone or the return air duct

Replacement Filter Media Kit With Frame (240 Only)

- Replaces existing pleated filter media
- Includes washable metal mesh screen and metal frame
- Clip holds replaceable non-pleated filter

19 PRODIGY® CONTROL SYSTEM



The Prodigy 2.0 unit controller is a microprocessor-based controller that provides flexible control of all unit functions.

Features:

- LCD Display
- Easy to read menu (4 lines x 20 character display)
- Buttons for menu navigation during setup and diagnostic
- Menu navigation LEDs for Data, Setup, Service, Settings
- Main Menu and Help Buttons for quick navigation to home screen and built-in help functions
- Scroll, Value Adjustment Select and Save Buttons
- Setup menu insures proper installation and simplified setup of the rooftop unit
- Profile setup copies key settings between units with the same configuration to reduce setup time
- USB port allows a technician to download and transfer unit information to help verify service was performed
- USB software updates on the Prodigy Control System enhance functionality without the need to change components
- Unit Controller Software
- Unit self-test verifies individual critical component and system performance
- Economizer test function assures economizer is operating correctly
- Time Clock with Run-Time Information

Built-In Functions Include:

- Adjustable Blower On/Off Delay
- Built-in Control Parameter Defaults
- Compressor Time-Off Delay
- DDC Compatible
- Dirty Filter Switch Input
- Discharge Air Temperature Control
- Display/Sensor Readout
- Economizer Control Options (See Economizer / Exhaust Air / Outdoor Air sections)
- Fresh Air Tempering
- Over 100 diagnostic and status messages in English
- Exhaust Fan Control Modes for fresh air damper position (differential pressure transducer or pressure switches)
- Permanent Diagnostic Code Storage
- Field Adjustable Control Parameters (Over 200 settings)
- Indoor Air Quality Input (Demand Control Ventilation)
- Low Ambient Controls for cooling operation down to 0°F

- Gas Valve Time Delay Between First and Second Stage
- Minimum Compressor Run Time
- Network Capable (Can be daisy chained to other units or controls)
- Night Setback Mode
- Return Air Temperature Limit Control
- Safety Switch Input allows Controller to respond to a external safety switch trip
- Service Relay Output
- Smoke Alarm Mode has four choices (unit off, positive pressure, negative pressure, purge)
- Up to 2 heat/2 cool (standard Prodigy unit controller thermostat input)
- Up to 3 cool with additional relay
- Up to 4 cool with room sensor or network operation
- "Strike Three" Protection
- Gas Reheat Control allows simultaneous heating and cooling operation for humidity control of process air applications such as supermarkets
- On Demand Dehumidification monitors and controls condenser hot gas reheat operation with Humiditrol® dehumidification option
- Thermostat Bounce Delay
- Warm Up Mode Delay
- LED Indicators
- PC Interface connects the Prodigy 2.0 unit controller to a PC with the Lennox Unit Controller Software
- Room Sensor Operation controls temperature

NOTE - Prodigy Control System features vary with the type of rooftop unit in which the control is installed.

NOTE - See separate Prodigy Control System Product Specifications Bulletin for additional information.

CONTROL SYSTEM

PRODIGY® CONTROL SYSTEM (continued)

Control Options

Factory Installed

Blower Proving Switch

- Monitors blower operation, shuts down unit if blower fails

Factory or Field Installed

Dirty Filter Switch

- Senses static pressure increase indicating dirty filter condition

Fresh Air Tempering

- Used in applications with high outside air requirements
- Controller energizes the first stage heat as needed to maintain a minimum supply air temperature for comfort, regardless of the thermostat demand
- When ordered as a factory option, sensor ships with the unit for field installation

Smoke Detector

- Photoelectric type
- Installed in supply air section, return air section or both sections
- Available with power board and single sensor (supply or return) or power board and two sensors (supply and return)
- Power board located in unit control compartment

Interoperability via BACnet® or LonTalk® Protocols

- Communication compatible with third-party automation systems that support the BACnet Application Specific Controller device profile, LonMark® Space Comfort Controller functional profile, or LonMark Discharge Air Controller functional profile

Commercial Control Systems

L Connection® Network Control System

- Complete building automation control system for single or multi-zone applications
- Options include local interface, software for local or remote communication, and hardware for networking other control functions
- See L Connection Network Control System Product Specifications Bulletin for details

After-Market DDC

- Novar® Unit Controller and options

Thermostats

- Control system and thermostat options
- After-Market unit controller options

Field Installed

General Purpose Control Kit

- Plug-in control provides additional analog and digital inputs/outputs for field installed options

OPTIONS / ACCESSORIES

20 ECONOMIZER

Factory or Field Installed

- Economizer operation is set and controlled by the Prodigy® 2.0 Unit Controller
- Simple plug-in connections from economizer to unit controller
- All Strategos rooftop units are equipped with factory installed CEC Title 24 approved sensors for outside, return and discharge air temperature monitoring

NOTE - Optional sensors may be used instead of unit sensors to determine whether outdoor air is suitable for free cooling. See Options/Accessories table.

High Performance Economizer Features

- Outdoor air hood is furnished
- Approved for California Title 24 building standards.
- Low leakage dampers are Air Movement and Control Association International (AMCA) Class 1A Certified - Maximum 3 CFM per sq. ft. leakage at 1 in. w.g.
- ASHRAE 90.1-2010 compliant
- Gear-driven action
- High torque 24-volt fully-modulating spring return damper motor
- Return air and outdoor air dampers
- Plug-in connections to unit
- Nylon bearings (036-060)
- Stainless steel bearings (120-240)
- Enhanced neoprene blade edge seals
- Flexible stainless steel jamb seals minimize air leakage.

NOTE - High Performance Economizers are not approved for use with enthalpy controls in Title 24 applications.

NOTE - The Free Cooling setpoint for Title 24 applications must be set based on the Climate Zone where the system is installed. See Section 140.4 "Prescriptive Requirements for Space Conditioning Systems" of the California Energy Commission's 2013 Building Energy Efficiency Standards.

NOTE - Refer to Installation Instructions for complete setup information.

OPTIONS / ACCESSORIES

ECONOMIZER (continued)

Options / Accessories

Field Installed

Global Control (Not for Title 24)

- The unit controller communicates with a DDC system with one global sensor (enthalpy or sensible)
- Determines whether outside air is suitable for free cooling on all units connected to the control system
- Sensor must be field provided

Single Enthalpy Temperature Control (Not for Title 24)

- Outdoor air enthalpy sensor enables Economizer if the outdoor enthalpy is less than the setpoint of the control.

Differential Enthalpy Control (Not for Title 24)

- Order two Single Enthalpy Controls
- One is field installed in the return air section
- One is installed in the outdoor air section
- Allows the economizer control to select between outdoor air or return air, whichever has lower enthalpy

EXHAUST AIR

Factory Installed

21 Power Exhaust Fan(s) (120 and 240 Models Only)

- Installs external on 10 ton model with economizer option
- Installs internal to 20 ton models with economizer option
- Provides exhaust air pressure relief
- Interlocked to run when supply air blower is operating
- Fan runs when outdoor air dampers are 50% open (adjustable)
- Fan motor is overload protected
- 10-ton model includes steel cabinet and hood painted to match unit

120 Model

- One, 1/2 hp motor
- Five fan blades
- Total power input - 300 Watts
- Total air volume of 4085 cfm at 0.05 in. w.g.

240 Model

- Three, 1/3 hp motors
- 20 in. diameter, five fan blades
- Total power input - 1200 Watts
- Total air volume of 10,200 cfm at 0 in. w.g.

Factory or Field Installed

Barometric Relief Dampers

- Allows relief of excess air
- Dampers prevent blow back and outdoor air infiltration during off cycle
- Outdoor air hood is furnished with field installed barometric relief dampers for 120-240 models with Power Exhaust
- See Options/Accessories table

OUTDOOR AIR

Factory Installed

Manual Outdoor Air Damper (240 Models Only)

- 0 to 25% (fixed) outdoor air adjustable slide damper
- Installed in unit
- Outdoor air hood with bird screen included.

Motorized Outdoor Air Dampers (240 Models Only)

- Linked dampers with a fully modulating spring return damper motor
- Installed in unit
- Outdoor air hood with bird screen included.

ROOF CURBS

Factory Installed

Curb Alignment (240 Models Only)

- Adapter plate mates new unit to existing roof curb for easy replacement of older LCE240 models

Field Installed

Hybrid Roof Curbs, Downflow

- Interlocking tabs fasten corners together
- No tools required
- Can also be fastened together with furnished hardware
- Available in 14 and 24 inch heights
- See Options/Accessories table

22 OVERVIEW

- Factory installed option designed to control humidity
- Provides dehumidification on demand using ASHRAE 90.1 recommended method for comfort conditioning humidity control
- Unit comes equipped with one row reheat coil, solenoid valve and humidity controller
- In addition to a thermostat or room sensor used for conventional operation, a humidity sensor is required and must be located in the occupied space
- Remote Mounted Humidity Sensor Kit is required for field installation
- Humidity sensor provides input to the Unit Controller which is used to control activation of the dehumidification operation
- Reheat controls are located in the compressor control section of the unit for easy access

BENEFITS

- Improves indoor air quality
- Helps prevent damage due to high humidity levels
- Improves comfort levels by reducing space humidity levels

OPERATION

No Dehumidification Demand

- The unit will operate conventionally whenever there is a demand for cooling or heating and no dehumidification demand
- Free cooling is only permitted when there is no demand for dehumidification

Dehumidification Demand Only

- The Unit Controller is factory set at 60% relative humidity setpoint and can be adjusted at the Unit Controller or with optional Unit Controller Software
- For L Connection® Network Control Panel (NCP) applications, the humidity setpoint can be adjusted at the NCP
- Reheat operation will initiate on a dehumidification demand and does not require a cooling demand
- The unit will operate in the dehumidification mode until the relative humidity of the conditioned space is below the setpoint
- The reheat coil is sized to provide 68°F to 75°F supply air during reheat operation
- This reduces sensible cooling capacity and extends compressor run time to control humidity when the cooling load is low
- A solenoid valve diverts hot gas from the compressor to the reheat coil
- The cooled and dehumidified air from the evaporator is reheated as it passes through the reheat coil
- The de-superheated and partially condensed refrigerant continues to the outdoor condenser coil where condensing is completed
- The unit will continue to operate in this mode until the dehumidification demand is satisfied

NOTE - See Sequence of Operation for additional information.

Dehumidification and Cooling Demand (Thermostat/ Room Sensor Application)

Two-stage compressor models (036 and 060)

- If both a dehumidification and a Y1 cooling demand occur, the system will operate in the full cooling mode at first stage indoor air flow
- If a Y2 cooling demand occurs along with a dehumidification demand, the system operates in full cooling mode at full cooling airflow until the Y2 cooling demand is satisfied
- Then the system will revert to the dehumidification mode if a dehumidification mode demand is present

Single Speed Compressor Model (120/240)

- If both a dehumidification and a full cooling demand occur, the system will operate in cooling until the cooling demand is satisfied
- Then the system will energize the dehumidification mode

Options/Accessories

Humidity Sensor Kit

- Remote Mounted Humidity sensor required with factory installed Humiditrol® Dehumidification Option or Supermarket reheat field selectable option

REFRIGERANT SCHEMATIC - 036H-60H MODELS

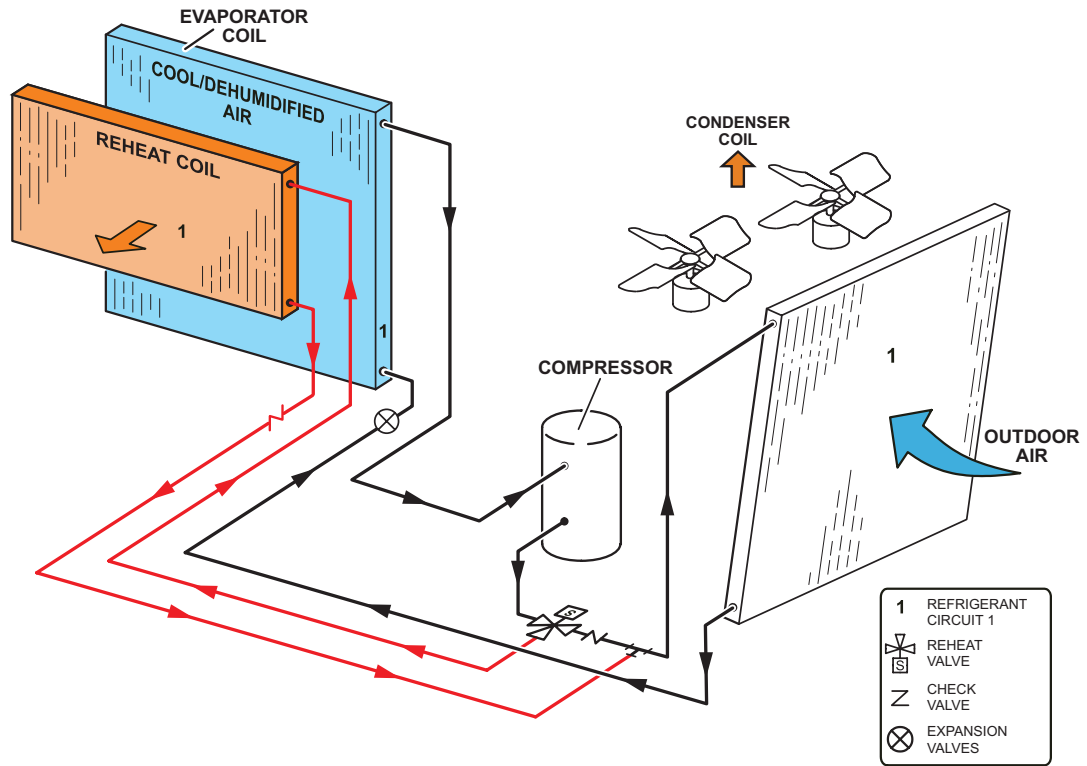

REFRIGERANT SCHEMATIC - 120H MODEL

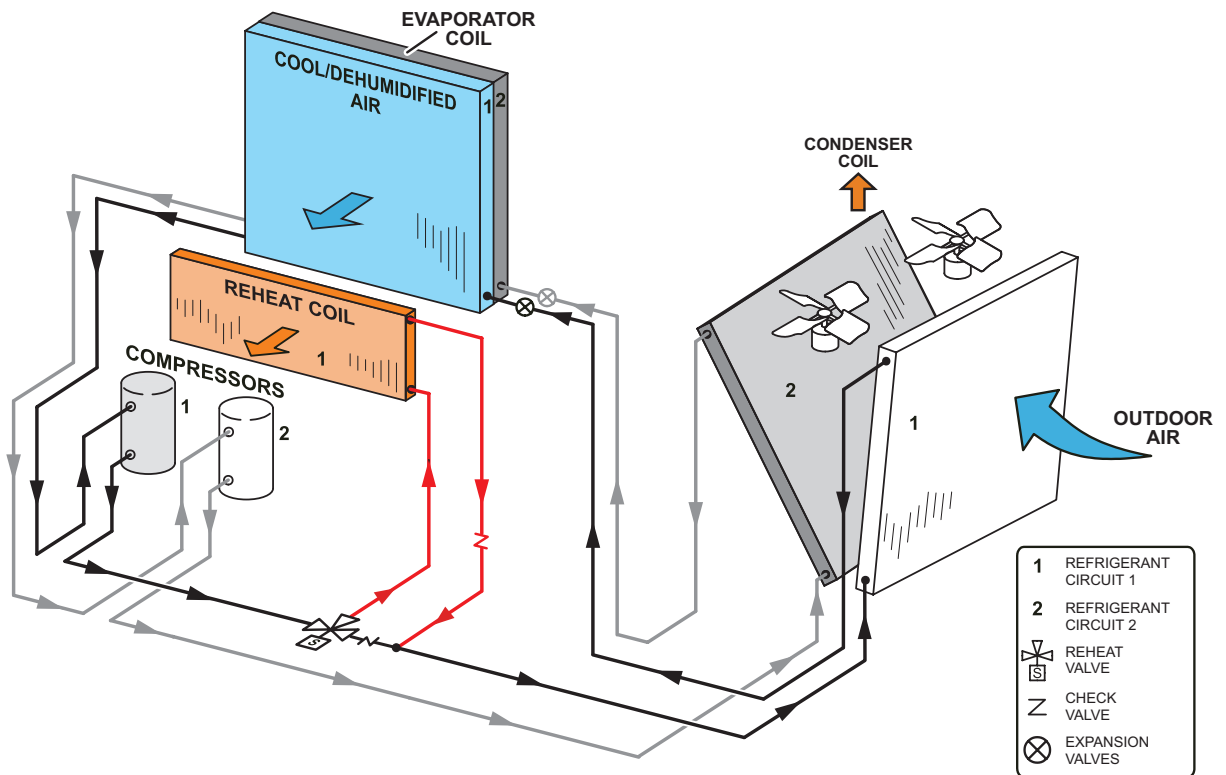

HUMIDITROL® DEHUMIDIFICATION SYSTEM

REFRIGERANT SCHEMATIC - 240H MODEL

NOTE: Refrigerant circuits one and two operates when there is a first - stage thermostat demand.

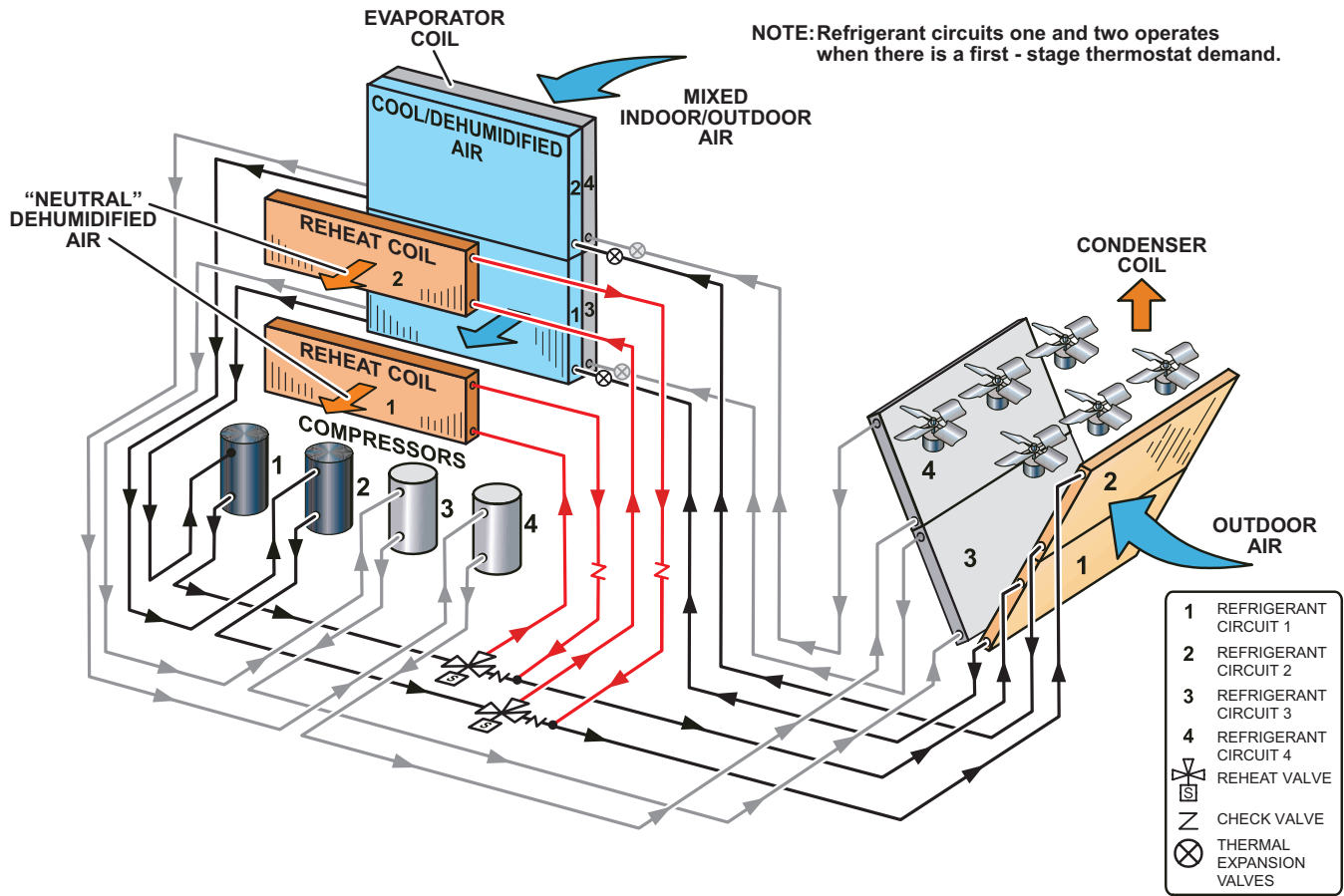

Objective: Outline the unit functions as a result of room thermostat or zone sensor demands.

Given: When economizer is present, it will function as initial part of the unit cooling system. When not present, unit will function as if outdoor ambient is high and sensed as not suitable.

DIRECT DRIVE SYSTEM OPERATION (3 AND 5 TONS MODELS):

Note: DirectPlus™ direct drive units feature ECM condenser fans that are staged to match the compressor's capacity. When the compressor is operating at first stage, the condenser fan is operating at low speed. The condenser fan switches to high speed when the compressor switches to second stage to match operation.

Modulating Outdoor Air Damper:

Damper minimum positions #1 and 2 are adjusted during unit setup to provide minimum fresh air requirements at the indicated supply fan speeds per ASHRAE 62.1.

- Supply fan is off and the outdoor air damper is closed
- Supply fan is on low speed and the outdoor air damper is at minimum position 1
- Supply fan is on high speed and the outdoor air damper is at minimum position 2

¹ Unit Features an Economizer and Outdoor Air is Suitable

Cooling - Thermostat (Up to 2 stages Y1, Y2) or Zone Sensor Mode (Up to 3 stages Y1, Y2, Y3)

Y1 Demand:

- 1st: Compressor is off, supply fan is on low speed, economizer modulates (minimum to maximum open position) to maintain 55°F supply air temperature (default unit controller setting)
- 2nd: After 5 minutes (default unit controller setting), supply fan switches to high speed. Economizer continues modulating with supply fan on high speed to maintain 55°F supply air temperature

Y2 Demand:

- 1st: Compressor is off, supply fan is on high speed, and economizer modulates to maintain 55°F supply air temperature
- 2nd: Economizer opens to maximum. If economizer stays at maximum open for 3 minutes (default unit controller setting) compressor is energized and operates at first stage while supply fan stays on high speed

¹ *Outdoor air suitability is determined by the energy state of outdoor ambient (enthalpy or sensible) and its ability to achieve the desired free cooling effects. Outdoor air suitability can also be determined by a third party controller and provided to the RTU via a network connection.*

Y3 Demand:

- 1st: Economizer is at maximum open and compressor operates at first stage. If economizer stays at maximum open for 3 minutes (default unit controller setting) compressor switches to second stage operation while supply fan stays on high speed

Unit Does not Feature an Economizer (or Outdoor Air Is Not Suitable)

Cooling - Thermostat or Zone Sensor (Up to 2 stages Y1, Y2)

Y1 Demand:

- 1st: Compressor operates at first stage and supply fan operates at low speed

Y2 Demand:

- 1st: Compressor operates at second stage and supply fan operates at high speed

DIRECT DRIVE SYSTEM OPERATION (3 AND 5 TONS MODELS) (CONTINUED):**Dehumidification Mode (economizer free cooling is locked out):**

Unit features the Humiditrol® Dehumidification option.

No Y1, Y2 Demand But A Call For Dehumidification:

1st: Compressor operates at second stage, supply fan operates at low speed, and the reheat valve is energized.

Y1 Demand:

1st: Compressor operates at second stage, outdoor fan operates at high speed, supply fan operates at low speed and the reheat valve is de-energized.

Y2 Demand:

1st: Compressor operates at second stage, supply fan operates at high speed, and the reheat valve is de-energized.

Heating Mode: (Thermostat or Zone Sensor (Up to 2 stages W1, W2))**W1 Demand:**

1st: Gas valve is open (stage 1 on units with 2 stage gas valve) and the supply fan operates at high speed.

W2 Demand:

1st: Gas valve is open (stage 2 on units with 2 stage gas valve) and the supply fan operates at high speed.

Heating Mode: Thermostat or Zone Sensor (Up to 4 stages W1, W2)**W1 Demand:**

1st: Gas valve is open in low and the supply fan operates at low speed.

After ten minutes the 1st gas valve closes, 2nd Gas valve opens in low and the supply fan operates at low speed.

W2 Demand:

1st and 2nd Gas valves open in low and the supply fan operates at high speed.

After ten minutes the 1st and 2nd Gas valves open in high and the supply fan operates at high speed.

If W2 demand is satisfied, but W1 is still present, 1st Gas valve is open in low and the supply fan operates at low speed.

Objective: Outline the unit functions as a result of room thermostat or zone sensor demands.

Given: When economizer is present, it will function as an integral part of the unit cooling system. When not present, unit will function as if economizer is present but outdoor ambient is high and sensed as not suitable.

UNIT OPERATION WITH 2-STAGE THERMOSTAT (2 COOL AND 2 HEAT STAGES, Y1, Y2, W1, W2)

SUPPLY AIR BLOWER SPEED

Unit has following supply air blower speed setting:

- Ventilation speed
- Cooling Speed - Low
- Cooling Speed - High
- Heating speed
- Smoke speed (Used only in smoke removal option - not discussed)

¹ Unit Features An Economizer And Outdoor Air Is Suitable

Cooling - Thermostat Mode (Y1, Y2)

Y1 Demand:

All compressors are off, supply air blower is on low cooling speed to minimize blower power consumption, economizer modulates (minimum to maximum open position) to maintain 55°F supply air temperature (default unit controller setting).

Y2 Demand:

All compressors are off, supply air blower is on high cooling speed providing higher cooling capacity, and economizer modulates to maintain 55°F supply air temperature.

If economizer stays at maximum open for 3 minutes, compressor 1 is energized while supply air blower stays on high cooling speed providing maximum cooling capacity.

¹ *Outdoor air suitability is determined by the energy state of outdoor ambient (enthalpy or sensible) and its ability to achieve the desired free cooling effects. Outdoor air suitability can also be determined by a third party controller and provided to the rooftop unit via a network connection.*

Unit Does Not Feature An Economizer Or Outdoor Air Is Not Suitable

Y1 Demand:

Compressor 1 operates and supply air blower operates at low cooling speed.

Y2 Demand:

All compressors operate and supply air blower operates at high cooling speed.

Dehumidification Mode

If a unit with Humiditrol® Dehumidification Option receives a call for dehumidification, economizer free cooling is locked out.

Call For Dehumidification, No Y1, Y2 Demand:

1st stage compressor operates, supply air blower operates at low cooling speed, and the reheat valve is energized.

Y1 Demand With A Call For Dehumidification:

All compressors operate, supply air blower operates at high cooling speed and the reheat valve is energized.

Y2 Demand With A Call For Dehumidification:

All compressors operate, supply air blower operates at high cooling speed, and the reheat valve is de-energized.

UNIT OPERATION WITH ZONE SENSOR (3 COOL AND 2 HEAT STAGES, Y1, Y2, Y3 AND W1, W2)**SUPPLY AIR BLOWER SPEED**

Unit has following supply air blower speed setting:

- Ventilation speed
- Cooling Speed - Low
- Cooling Speed - High
- Heating speed
- Smoke speed (Used only in smoke removal option - not discussed)

¹ Unit Features An Economizer And Outdoor Air Is Suitable

Cooling - Thermostat or Zone Sensor Mode (Y1, Y2, Y3)

Y1 Demand:

All compressors are off, supply air blower is on low cooling speed to minimize blower power consumption, economizer modulates (minimum to maximum open position) to maintain 55°F supply air temperature (default unit controller setting).

Y2 Demand:

All compressors are off, supply air blower is on high cooling speed providing higher cooling capacity, and economizer modulates to maintain 55°F supply air temperature.

If economizer stays at maximum open for 3 minutes, compressor 1 is energized while supply air blower stays on high cooling speed providing maximum cooling capacity. After compressors are energized the economizer stays at maximum open.

Y3 Demand:

Compressors 1 and 2 are energized while supply air blower stays on high cooling speed.

¹ *Outdoor air suitability is determined by the energy state of outdoor ambient (enthalpy or sensible) and its ability to achieve the desired free cooling effects. Outdoor air suitability can also be determined by a third party controller and provided to the rooftop unit via a network connection.*

Unit Does Not Feature An Economizer Or Outdoor Air Is Not Suitable**Y1 Demand:**

Compressor 1 operates and supply air blower operates at low cooling speed.

Y2 or Y3 Demand:

All compressors operate and supply air blower operates at high cooling speed.

Dehumidification Mode

If a unit with Humiditrol® Dehumidification Option receives a call for dehumidification, economizer free cooling is locked out.

Call For Dehumidification, No Y1, Y2 demand:

1st stage compressor operates, supply air blower operates at low cooling speed, and the reheat valve is energized.

Y1 Demand With A Call For Dehumidification:

All compressors operate, supply air blower operates at high cooling speed and the reheat valve is energized.

Y2 Or Y3 Demand With A Call For Dehumidification:

All compressors operate, supply air blower operates at high cooling speed, and the reheat valve is de-energized.

UNIT OPERATION WITH ZONE SENSOR (3 COOL AND 2 HEAT STAGES, Y1, Y2, Y3 AND W1, W2) (CONTINUED)**Heating Mode**

NOTE - Heating mode is the same for all control options

W1 Demand:

Gas valves are open (stage 1 on units with 2-stage gas valves) and supply air blower operates at heating speed.

W2 Demand:

Gas valves are open (stage 2 on units with 2-stage gas valves) and supply air blower operates at heating speed.

Modulating Outdoor Air Damper

The minimum damper position for “occupied low blower” and “occupied high blower” is adjusted during unit setup to provide minimum fresh air requirements per ASHRAE 62.1 at the corresponding supply air blower speeds.

- When supply air blower is off or the unit is in unoccupied mode, the outdoor air damper is closed.
- When unit is in occupied mode and supply air blower is operating at a speed below the “midpoint” blower speed, the outdoor air damper is at minimum “low blower” position.
- When unit is in occupied mode and supply air blower is operating at a speed equal to or above the “midpoint” blower speed, the outdoor air damper is at minimum “high blower” position.

NOTE - The “midpoint” blower speed is an average of the minimum and maximum blower speed (minimum speed + maximum speed divided by 2).

Power Exhaust Operation

NOTE - Power exhaust operation is the same for all control options

Power exhaust blower operates when economizer outdoor air dampers are 50% open (adjustable) and when supply air blower speed is above 70% (adjustable) of full speed.

Objective: Outline the unit functions as a result of room thermostat or zone sensor demands.

Given: When economizer is present, it will function as an integral part of the unit cooling system. When not present, unit will function as if economizer is present but outdoor ambient is high and sensed as not suitable.

UNIT WITH 2-STAGE THERMOSTAT (2 COOLING STAGES, Y1, Y2)

SUPPLY AIR BLOWER SPEED

Unit has following supply air blower speed setting:

- Ventilation Speed
- Cooling Speed - Low
- Cooling Speed - High
- Heating Speed
- Smoke Speed (Used only in smoke removal option - not discussed)

¹ Unit Features An Economizer And Outdoor Air Is Suitable

Y1 Demand:

All compressors are off, supply air blower is on low cooling speed to minimize blower power consumption, economizer modulates (minimum to maximum open position) to maintain 55°F supply air temperature (default unit controller setting).

Y2 Demand:

All compressors are off, supply air blower is on high cooling speed providing higher cooling capacity, and economizer modulates to maintain 55°F supply air temperature.

If economizer stays at maximum open for 3 minutes, 1st stage compressors (compressor 1 and 2) are energized while supply air blower stays on high cooling speed providing maximum cooling capacity.

¹ *Outdoor air suitability is determined by the energy state of outdoor ambient (enthalpy or sensible) and its ability to achieve the desired free cooling effects. Outdoor air suitability can also be determined by a third party controller and provided to the RTU via a network connection.*

Unit Does Not Feature An Economizer Or Outdoor Air Is Not Suitable

Y1 Demand:

1st stage compressors operate and supply air blower operates at low cooling speed.

Y2 Demand:

All compressors operate and supply air blower operates at high cooling speed.

Dehumidification Mode

If a unit with Humiditrol® Dehumidification Option receives a call for dehumidification, economizer free cooling is locked out.

Call For Dehumidification, No Y1, Y2 Demand:

1st stage compressors (1 & 2) operate, supply air blower operates at low cooling speed, and the reheat valves are energized.

Y1 Demand With A Call For Dehumidification:

All compressors operate, supply air blower operates at high cooling speed and the reheat valves are energized.

Y2 Demand With A Call For Dehumidification:

All compressors operate, supply air blower operates at high cooling speed, and the reheat valves are de-energized.

UNIT WITH ZONE SENSOR (4 COOLING STAGES, Y1, Y2, Y3, Y4)**SUPPLY AIR BLOWER SPEED**

Unit has following supply air blower speed setting:

- Ventilation speed
- Cooling Speed 1 (Low)
- Cooling Speed 2 (Medium-Low)
- Cooling Speed 3 (Medium-High)
- Cooling Speed 4 (High)
- Heating Speed
- Smoke Speed (Used only in smoke removal option - not discussed)

¹ Unit Features An Economizer And Outdoor Air Is Suitable**Y1 Demand:**

All compressors are off, supply air blower is on cooling speed 1 to minimize blower power consumption, economizer modulates (minimum to maximum open position) to maintain 55°F supply air temperature (default unit controller setting).

Y2 Demand:

All compressors are off, supply air blower is on cooling speed 4 providing higher cooling capacity, and economizer modulates to maintain 55°F supply air temperature.

If economizer stays at maximum open for 3 minutes, compressor 1 is energized while supply air blower stays on cooling speed 4. After compressor 1 is energized the economizer stays at maximum open.

Y3 Demand:

Compressor 1 and 2 are energized while supply air blower is on cooling speed 4 providing even higher cooling capacity.

Y4 Demand:

All compressors are energized while supply air blower is on cooling speed 4 providing maximum cooling capacity.

¹ Outdoor air suitability is determined by the energy state of outdoor ambient (enthalpy or sensible) and its ability to achieve the desired free cooling effects. Outdoor air suitability can also be determined by a third party controller and provided to the RTU via a network connection.

Unit Does Not Feature An Economizer (Or Outdoor Air Is Not Suitable)**Y1 Demand:**

Compressor 1 operates and supply air blower operates at cooling speed 1.

Y2 Demand:

Compressors 1 and 2 operate and supply air blower operates at cooling speed 2.

Y3 Demand:

Compressors 1, 2, and 3 operate and supply air blower operates at cooling speed 3.

Y4 Demand:

All compressors operate and supply air blower operates at cooling speed 4.

UNIT WITH ZONE SENSOR (4 COOLING STAGES, Y1, Y2, Y3, Y4) (CONTINUED)**Dehumidification Mode**

If a unit with Humiditrol® Dehumidification Option receives a call for dehumidification, economizer free cooling is locked out.

Call For Dehumidification, No Y1, Y2, Y3, Y4 Demand:

Compressors 1 and 2 operate, supply air blower operates at medium-low cooling speed 2, and both reheat valves are energized.

Y1 Demand With A Call For Dehumidification:

Compressors 1, 2, and 3 operate, supply air blower operates at high cooling speed and both reheat valves are energized.

Y2 Demand With A Call For Dehumidification:

All compressors operate, supply air blower operates at cooling speed 4 and both reheat valves are energized.

Y3 Demand With A Call For Dehumidification:

All compressors operate, supply air blower operates at cooling speed 4, and the reheat valve of compressor 1 is energized while the reheat valve of compressor 2 is de-energized.

Y4 Demand With A Call For Dehumidification:

All compressors operate, supply air blower operates at cooling speed 4, and the reheat valves are de-energized.

Heating Mode

NOTE - Heating Mode Is The Same For All Control Options.

W1 Demand:

Gas valves are open (stage 1 on units with 2-stage gas valves) and supply air blower operates at heating speed.

W2 Demand:

Gas valves are open (stage 2 on units with 2-stage gas valves) and supply air blower operates at heating speed.

Modulating Outdoor Air Damper

The minimum damper position for “occupied low blower” and “occupied high blower” is adjusted during unit setup to provide minimum fresh air requirements per ASHRAE 62.1 at the corresponding supply air blower speeds.

- When supply air blower is off or the unit is in unoccupied mode, the outdoor air damper is closed.
- When unit is in occupied mode and supply air blower is operating at a speed below the “midpoint” blower speed, the outdoor air damper is at minimum “low blower” position.
- When unit is in occupied mode and supply air blower is operating at a speed equal to or above the “midpoint” blower speed, the outdoor air damper is at minimum “high blower” position.

NOTE - The “midpoint” blower speed is an average of the minimum and maximum blower speed (minimum speed + maximum speed divided by 2).

Power Exhaust Operation

NOTE - Power Exhaust Operation Is The Same For All Control Options

MSAV models are equipped with 2-stage power exhaust fans. Power exhaust fans operate when economizer outdoor air dampers are 50% open (adjustable). Power exhaust operates in 1st stage (one fan) up to 70% of supply air blower speed. 2nd stage power exhaust fans (both fans) operate when supply air blower speed is above 70% (adjustable) of full speed.

OPTIONS / ACCESSORIES

Item Description	Model Number	Catalog Number	Unit Model No.			
			036	060	120	240
COOLING SYSTEM						
Condensate Drain Trap		Factory	O	O	O	O
Corrosion Protection	Coated indoor/outdoor coil assemblies, painted cabinet interior	Factory	O	O	O	O
	Coated outdoor coil assembly	Factory	O	O	O	O
Drain Pan Overflow Switch	E1SNSR71AD1	68W88	OX	OX	OX	OX
HEATING SYSTEM						
Combustion Air Intake Extension	C1EXTN10101	20X99	X	X		
	C1EXTN10111	33W62			X	
	C1EXTN10FF1	89L97				¹ X
Gas Heat Input	Standard 2 Stage - 53/70 kBtuh input (Low NOX)	Factory	O	O		
	Medium 2 Stage - 81/108 kBtuh input (Low NOX)	Factory	O	O		
	High 2 Stage - 113/150 kBtuh input (Low NOX)	Factory		O		
	Standard 2 Stage - 84.5/130 kBtuh input	Factory			O	
	Medium 2 Stage - 117/180 kBtuh input	Factory			O	
	High 2 Stage - 156/240 kBtuh input	Factory			O	
	Standard 2 Stage - 169/260 kBtuh input	Factory				O
	Medium 2 Stage - 234/360 kBtuh input	Factory				O
	High 2 Stage - 312/480 kBtuh input	Factory				O
LPG/Propane Kits	2 Stage Standard Heat - C1PROP28A11	21A01	X	X		
	2 Stage Medium and High Heat - C1PROP20AP2	14N21	X	X		
	Standard Heat - C1PROP25C11	14N28			X	¹ X
	Medium Heat - C1PROP26C11	14N29			X	¹ X
	High Heat - C1PROP27C11	14N30			X	¹ X
Low Temperature Vestibule Heater		Factory	O	O	O	O
Stainless Steel Heat Exchanger		Factory	O	O	O	O
Vertical Vent Extension	C1EXTN20FF1	31W62	X	X		
	LTAWEK10/15	73M72			X	
	C1EXTN2021	42W16				¹ X
BLOWER - SUPPLY AIR						
ECM Direct Drive, MSAV® (Multi-Stage Air Volume)	1.5 hp	Factory	O	O		
Belt Drive, MSAV® (Multi-Stage Air Volume)	3 hp	Factory			O	
	5 hp	Factory				O
	7.5 hp	Factory				O
CABINET						
Combination Coil/Hail Guards	S1GARD22101	19H54	OX	OX		
	S1GARD22111	19H55			OX	
	C1GARD52D-1	13T16				OX

¹ Order two.

NOTE - Catalog and model numbers shown are for ordering field installed accessories.

OX - Configure To Order (Factory Installed) or Field Installed

O = Configure To Order (Factory Installed)

X = Field Installed

OPTIONS / ACCESSORIES

Item Description	Model Number	Catalog Number	Unit Model No.			
			036	060	120	240
CONTROLS						
Blower Proving Switch		Factory	O	O	O	O
Commercial Controls	Prodigy® Control System - BACnet® Module	Factory	O	O	O	O
	Prodigy® Control System - LonTalk® Module	Factory	O	O	O	O
	CPC Einstein Integration	Factory	O	O	O	O
	L Connection® Network	Factory	O	O	O	O
Dirty Filter Switch	S1SNSR55S-1	12P68	OX	OX	OX	OX
Fresh Air Tempering	C1SNSR75AD1	58W63	X	X	X	X
¹ Smoke Detector	Supply	Factory	O	O	O	O
	Return	Factory	O	O	O	O
ELECTRICAL						
Voltage 60 hz	208/230V - 3 phase	Factory	O	O	O	O
	460V - 3 phase	Factory	O	O	O	O
	575V - 3 phase	Factory	O	O	O	O
GFI Service Outlets	20 amp non-powered, field-wired (all voltages)	C1GFCl20FF1	67E01	OX	OX	OX
	15 amp, factory-wired and powered	C1GFCl15FF1	74M70			OX
² Short-Circuit Current Rating (SCCR) of 100kA (includes Phase/Voltage Detection)		Factory				O
Weatherproof Cover for GFI	C1GFGCI99FF1	10C89	X	X	X	X
INDOOR AIR QUALITY						
Air Filters						
Healthy Climate® High Efficiency Air Filters	MERV 13 (16 x 20 x 2 - Order 4 per unit)	C1FLTR40A-1	52W37	X	X	
	MERV 13 (20 x 25 x 2 - Order 4 per unit)	C1FLTR40B-1	52W41			X
	MERV 13 (20 x 20 x 2 - Order 12 per unit)	C1FLTR40D-1	52W39			X
Replacement Media Filter With Metal Mesh Frame 20 x 20 x 2 Order 12 per unit (includes non-pleated filter media)	C1FLTR30D-1-	44N60				X
Indoor Air Quality (CO₂) Sensors						
Sensor - Wall-mount, off-white plastic cover with LCD display	C0SNSR50AE1L	77N39	X	X	X	X
Sensor - Wall-mount, off-white plastic cover, no display	C0SNSR52AE1L	87N53	X	X	X	X
Sensor - Black plastic case with LCD display, rated for plenum mounting	C0SNSR51AE1L	87N52	X	X	X	X
Sensor - Wall-mount, black plastic case, no display, rated for plenum mounting	C0MISC19AE1	87N54	X	X	X	X
CO ₂ Sensor Duct Mounting Kit - for downflow applications	C0MISC19AE1-	85L43	X	X	X	X
Aspiration Box - for duct mounting non-plenum rated CO ₂ sensors (87N53 or 77N39)	C0MISC16AE1-	90N43	X	X	X	X
HUMIDITROL® CONDENSER REHEAT OPTION						
Humiditrol® Dehumidification Option		Factory	O	O	O	O
Humidity Sensor Kit, Remote mounted (required)	C0SNSR31AE-1	17M50	X	X	X	X

¹ Factory installed smoke detectors must be ordered for use with either 115V or 24V external power supply only.

² SCCR option not available with 208/230V units.

NOTE - Catalog and model numbers shown are for ordering field installed accessories.

OX - Configure To Order (Factory Installed) or Field Installed

O = Configure To Order (Factory Installed)

X = Field Installed

OPTIONS / ACCESSORIES

Item Description	Model Number	Catalog Number	Unit Model No.			
			036	060	120	240
ECONOMIZER						
High Performance Economizer (Approved for California Title 24 Building Standards / AMCA Class 1A Certified)						
Standard Economizer - Includes Outdoor Air Hood (Global Sensor, field provided, order Barometric Relief Dampers separately)	E1ECON17D-2	Factory 18X87	O	O	O	OX
Economizer Controls (Not for Title 24)						
Single Enthalpy NOTE - For Differential Enthalpy Order 2 Single Enthalpy Controls	C1SNSR64FF1	53W64	OX	OX	OX	OX
Barometric Relief Dampers						
Barometric Relief Dampers (No Exhaust Hood)		30W72	OX	OX		
Barometric Relief Dampers With Power Exhaust Fans (Exhaust Hood Furnished)		30W92			OX	
Barometric Relief Dampers Without Power Exhaust Fans (No Exhaust Hood)		47M14			OX	
Barometric Relief Dampers Without Power Exhaust Fans (Exhaust Hood Furnished)		76W17				OX
POWER EXHAUST						
Standard Static		Factory			O	O
OUTDOOR AIR						
Manual Outdoor Air Damper with Outdoor Air Hood and Bird Screen		Factory				O
Motorized Outdoor Air Dampers with Outdoor Air Hood and Bird Screen		Factory				O
ROOF CURBS						
Hybrid Roof Curbs, Downflow, 14 in. height	S1CURB71101	11F70	X	X		
	S1CURB71111	11F72			X	
	Full Perimeter - S1CURB71121	11F74				X
Hybrid Roof Curbs, Downflow 24 in. height	S1CURB73101	11F71	X	X		
	S1CURB73111	11F73			X	
	Full Perimeter - S1CURB73121	11F75				X
Curb Alignment (Adapter plate mates new unit to existing roof curb for replacement of LGE240)		Factory				O

NOTE - Catalog and model numbers shown are for ordering field installed accessories.

OX - Configure To Order (Factory Installed) or Field Installed

O = Configure To Order (Factory Installed)

X = Field Installed

SPECIFICATIONS		DIRECT DRIVE 3 - 5 TON	
General Data	Nominal Tonnage	3 Ton	5 Ton
	Model No.	SGH036H4E	SGH060H4E
	Efficiency Type	High	High
	Blower Type	MSAV® (Multi-Stage Air Volume) (Direct Drive ECM)	MSAV® (Multi-Stage Air Volume) (Direct Drive ECM)
Cooling Performance	Gross Cooling Capacity - Btuh	37,200	60,300
	¹ Net Cooling Capacity - Btuh	36,000	59,000
	AHRI Rated Air Flow - cfm	1200	1700
	Total Unit Power	2.6	4.5
	¹ SEER (Btuh/Watt) - 208/230V-3ph	19.3	17.8
	¹ SEER (Btuh/Watt) - 460V/575V-3ph	18.6	17.4
	¹ EER (Btuh/Watt) - 208/230V-3ph	14.2	13.0
	¹ EER (Btuh/Watt) - 460V/575V-3ph	13.9	12.8
Refrigerant Charge	Refrigerant Type	R-410A	R-410A
	Environ™ Coil System	7 lbs. 11 oz.	8 lbs. 3 oz.
	Environ™ Coil System With Humiditrol® Dehumidification Option	8 lbs. 4 oz.	8 lbs. 4 oz.
² Sound Rating Number (dBA)		67	78
Gas Heating Options Available - See page 23		Standard (2 Stage) Medium (2 Stage)	Standard (2 Stage) Medium (2 Stage) High (2 Stage)
Compressor Type (No.)		Two-Stage Scroll (1)	Two-Stage Scroll (1)
Condenser Coil	Net face area - sq. ft.	18.7	18.7
	Number of rows	1	1
	Fins per inch	23	23
Condenser Fan(s)	Motor (No.) horsepower	(2) 1/3 (ECM)	(2) 1/3 (ECM)
	Motor rpm	340-560	340-860
	Total Motor watts	90-136	90-354
	Diameter (No.) - in.	(2) 24	(2) 24
	Number of blades	3	3
	Total air volume - cfm	3900	6300
	Evaporator Coil	Net face area - sq. ft.	7.78
Tube diameter - in.		3/8	3/8
Number of rows		4	4
Fins per inch		14	14
Drain connection - no. & size		(1) 1 NPT	(1) 1 NPT
Expansion device type		Balance Port TXV, removable head	
³ Indoor Blower	Nominal motor output HP	1.5 (ECM)	1.5 (ECM)
	Wheel nominal diameter x width - in.	(1) 14 x 5	(1) 14 x 5
Filters	Type of filter	MERV 8 or equivalent	
	Number and size - in.	(4) 16 x 20 x 2	(4) 16 x 20 x 2
Electrical characteristics		208/230V, 460V, or 575V - 60 hertz - 3 phase	

NOTE - Net capacity includes evaporator blower motor heat deduction. Gross capacity does not include evaporator blower motor heat deduction.

¹ AHRI Certified to AHRI Standard 210/240; 95°F outdoor air temperature and 80°F db/67°F wb entering evaporator air; minimum external duct static pressure.

² Sound Rating Number rated in accordance with test conditions included in AHRI Standard 270-95.

³ Using total air volume and system static pressure requirements determine from blower performance tables rpm and motor output required. Maximum usable output of motors furnished are shown. In Canada, nominal motor output is also maximum usable motor output. If motors of comparable output are used, be sure to keep within the service factor limitations outlined on the motor nameplate.

SPECIFICATIONS			BELT DRIVE 10 - 20 TON		
General Data	Nominal Tonnage		10 Ton	20 Ton	
	Model No.		SGH120H4M	SGH240H4M	
	Efficiency Type		High	High	
	Blower Type		MSAV® (Multi-Stage Air Volume) (Belt Drive)	MSAV® (Multi-Stage Air Volume) (Belt Drive)	
Cooling Performance	Gross Cooling Capacity - Btuh		121,000	239,000	
	¹ Net Cooling Capacity - Btuh		117,000	232,000	
	AHRI Rated Air Flow - cfm		3800	7000	
	Total Unit Power		10.0	19.3	
	¹ EER (Btuh/Watt)		11.6	12.0	
	¹ IEER (Btuh/Watt)		15.2	16.8	
Refrigerant Charge	Refrigerant Type		R-410A	R-410A	
	Environ™ Coil System	Circuit 1	9 lbs. 6 oz.	8 lbs. 8 oz.	
		Circuit 2	6 lbs. 1 oz.	8 lbs. 6 oz.	
		Circuit 3	---	6 lbs. 13 oz.	
		Circuit 4	---	7 lbs. 0 oz.	
	Environ™ Coil System With Humiditrol® Dehumidification Option	Circuit 1	10 lbs. 0 oz.	8 lbs. 8 oz.	
		Circuit 2	6 lbs. 1 oz.	8 lbs. 6 oz.	
		Circuit 3	---	6 lbs. 13 oz.	
		Circuit 4	---	7 lbs. 0 oz.	
	² Sound Rating Number (dBA)			89	92
Gas Heating Options Available - See page 23			Standard (2 Stage) Medium (2 Stage) High (2 Stage)	Standard (2 Stage) Medium (2 Stage) High (2 Stage)	
Compressor Type (No.)			Scroll (2)	Scroll (4)	
Condenser Coil	Net face area - sq. ft.		45.7	68.3	
	Fins per inch		23	23	
Condenser Fan(s)	Motor (No.) horsepower		(2) 1/2	(6) 1/3	
	Motor rpm		1075	1075	
	Total Motor watts		1160	1900	
	Diameter (No.) - in.		(2) 24	(6) 24	
	Number of blades		4	3	
	Total air volume - cfm		10,000	22,500	
Evaporator Coil	Net face area - sq. ft.		13.54	32.2	
	Tube diameter - in.		3/8	3/8	
	Number of rows		4	3	
	Fins per inch		14	14	
	Drain connection - no. & size		(1) 1 NPT	(1) 1 NPT	
	Expansion device type		Balance Port TXV, removable head		
³ Indoor Blower	Nominal motor HP		3	5	7.5
	RPM Range (Standard Static)		Drive #3 - 660-900 rpm	Drive #4 - 520-685 rpm	Drive #7 - 770-965 rpm
	RPM Range (High Static)		Drive #4 - 865-1080 rpm	Drive #5 - 685-865 rpm	---
	Wheel nominal diameter x width - in.		(1) 15 x 15	(2) 18 x 15	(2) 18 x 15
Filters	Type of filter		MERV 8 or equivalent		
	Number and size - in.		(4) 20 x 25 x 2	(12) 20 x 20 x 2	
Electrical characteristics			208/230V, 460V, or 575V - 60 hertz - 3 phase		

NOTE - Net capacity includes evaporator blower motor heat deduction. Gross capacity does not include evaporator blower motor heat deduction.

¹ AHRI Certified to AHRI Standard 340/360: 95°F outdoor air temperature and 80°F db/67°F wb entering evaporator air; minimum external duct static pressure..

² Sound Rating Number rated in accordance with test conditions included in AHRI Standard 270-95.

³ Using total air volume and system static pressure requirements determine from blower performance tables rpm and motor output required. Maximum usable output of motors furnished are shown. In Canada, nominal motor output is also maximum usable motor output. If motors of comparable output are used, be sure to keep within the service factor limitations outlined on the motor nameplate.

NOTE – Units equipped with MSAV® (Multi-Stage Air Volume) are limited to a motor service factor of 1.0.

SPECIFICATIONS - GAS HEAT
3 TON | 5 TON

Model No.		036 060	036 060	060
Heat Input Type		Standard (2 Stage)	Medium (2 Stage)	High (2 Stage)
Input Btuh	1st Stage	53,000	81,000	113,000
	2nd Stage	70,000	108,000	150,000
Output Btuh	2nd Stage	57,000	87,000	121,000
Temperature Rise Range - °F		15-45	25-55	40-70
¹ Thermal Efficiency		80%	80%	80%
Gas Supply Connections		3/4 in. npt	3/4 in. npt	3/4 in. npt
Rec. Gas Supply Pressure - Nat./ LPG		7 in. w.g. / 11 in. w.g.	7 in. w.g. / 11 in. w.g.	7 in. w.g. / 11 in. w.g.

¹ Thermal Efficiency at full input.

SPECIFICATIONS - GAS HEAT
10 TON | 20 TON

Model No.		120			240		
Heat Input Type		Standard (2 Stage)	Medium (2 Stage)	High (2 Stage)	Standard (2 Stage)	Medium (2 Stage)	High (2 Stage)
Input Btuh	1st Stage	84,500	117,000	156,000	169,000	234,000	312,000
	2nd Stage	130,000	180,000	240,000	260,000	360,000	480,000
Output Btuh	2nd Stage	104,000	144,000	192,000	208,000	288,000	384,000
Temperature Rise Range - °F		15-45	30-60	40-70	15-45	30-60	40-70
¹ Thermal Efficiency		80%	80%	80%	80%	80%	80%
Gas Supply Connections		3/4 in. npt	3/4 in. npt	3/4 in. npt	1 in. npt	1 in. npt	1 in. npt
Rec. Gas Supply Pressure - Nat./ LPG		7 in. w.g. / 11 in. w.g.			7 in. w.g. / 11 in. w.g.		

¹ Thermal Efficiency at full input.

HIGH ALTITUDE DERATE

NOTE - Units may be installed at altitudes up to 2000 ft. above sea level without any modifications.

At altitudes above 2000 ft. units must be derated to match information in the table shown.

At altitudes above 4500 ft. unit must be derated 2% for each 1000 ft. above sea level.

NOTE - This is the only permissible derate for these units.

Model	Heat Input Type	Altitude Feet	Gas Manifold Pressure - in. w.g. (min./max.)		Input Rate Natural Gas Btuh (min./max.)	Input Rate LPG/Propane Btuh (min./max.)
			Natural Gas	LPG/Propane		
036 060	Standard (2 Stage)	0 - 2000	2.0/3.5	5.9/10.5	53,000 / 70,000	53,000 / 70,000
		2001 - 4500	1.7/3.0	5.1/9.0	49,000 / 65,000	49,000 / 65,000
	Medium (2 Stage)	0 - 2000	2.0/3.5	5.9/10.5	81,000 / 108,000	81,000 / 108,000
		2001 - 4500	1.7/3.0	5.1/9.0	75,000 / 100,000	75,000 / 100,000
060 only	High (2 Stage)	0 - 2000	2.0/3.5	5.9/10.5	113,000 / 150,000	113,000 / 150,000
		2001 - 4500	1.7/3.0	5.1/9.0	104,000 / 139,000	104,000 / 139,000
120	Standard (2 Stage)	0 - 2000	1.6/3.7	5.5/10.5	84,500 / 130,000	94,000 / 130,000
		2001 - 4500	1.6/3.4	5.5/9.6	84,500 / 124,000	94,000 / 124,000
	Medium (2 Stage)	0 - 2000	1.6/3.7	5.5/10.5	117,000 / 180,000	130,000 / 180,000
		2001 - 4500	1.6/3.4	5.5/9.6	117,000 / 172,000	130,000 / 172,000
	High (2 Stage)	0 - 2000	1.6/3.7	5.5/10.5	156,000 / 240,000	173,000 / 240,000
		2001 - 4500	1.6/3.4	5.5/9.6	156,000 / 230,000	173,000 / 230,000
240	Standard (2 Stage)	0 - 2000	1.6/3.7	5.5/10.5	169,000 / 260,000	187,000 / 260,000
		2001 - 4500	1.6/3.4	5.5/9.6	169,000 / 249,000	187,000 / 249,000
	Medium (2 Stage)	0 - 2000	1.6/3.7	5.5/10.5	234,000 / 360,000	259,000 / 360,000
		2001 - 4500	1.6/3.4	5.5/9.6	234,000 / 345,000	259,000 / 345,000
	High (2 Stage)	0 - 2000	1.6/3.7	5.5/10.5	312,000 / 480,000	346,000 / 480,000
		2001 - 4500	1.6/3.4	5.5/9.6	312,000 / 460,000	346,000 / 460,000

SPECIFICATIONS**PRODIGY® CONTROL SYSTEM**

Operating Environment	Temperature: -40°F to 155°F
	Humidity: 10% - 95% RH, Non- Condensing
Power Requirements	24VAC (+/-25%), 50/60Hz
	4.8 VA for M2 maximum
	14.4 VA for M2 w/all expansion boards Maximum
Memory Type	Re-programmable Flash
Device Commissioning	Auto-poll (real plug and play)
Unit type	Electric/Electric, Gas/Electric & Heat Pumps (Rooftops)
Cooling stages	4
Heating stages	4
Modulating Gas Valves	2
Electronic Configure To Order Parameters	239
Alarm Codes	107
Alarm Codes Stored	84
Display Type	Scrolling, 7 plus Character Red LED
Indicator LEDs	1- Heartbeat on each board
	1- Bus transmit
	1 - Bus receive
	1- each for Y1,Y2,W1,W2,G,OCP
Dimensions - Main Board	Main Board: Height: 8 in., Width: 14-1/2 in., Depth: 6 in.
Weight	2 lbs. for M2 w/all modules installed
Cable Type	SysBus - Lennox yellow COMM cable: COMISC00AE1- (27M19) (500 ft. box), COMISC04AE1- (94L63) (1000 ft. box), COMISC01AE1- (68M25) (2500 ft. roll) ZoneBus - Lennox purple COMM cable: COMISC05AE1- (23W99) (500 ft. box) COMISC06AE1- (24W00) (1000 ft)

RATINGS

NOTE - For Temperatures and Capacities not shown in tables, see bulletin - Cooling Unit Rating Table Correction Factor Data in Miscellaneous Engineering Data section.

3 TON HIGH EFFICIENCY SGH036H4E - (1ST STAGE)

Entering Wet Bulb Temperature	Total Air Volume	Outdoor Air Temperature Entering Outdoor Coil																			
		65°F					75°F					85°F					95°F				
		Total Cool Cap.	Comp. Motor Input	Sensible To Total Ratio (S/T)			Total Cool Cap.	Comp. Motor Input	Sensible To Total Ratio (S/T)			Total Cool Cap.	Comp. Motor Input	Sensible To Total Ratio (S/T)			Total Cool Cap.	Comp. Motor Input	Sensible To Total Ratio (S/T)		
				Dry Bulb					Dry Bulb					Dry Bulb					Dry Bulb		
		cfm	kBtuh	kW	75°F	80°F	85°F	kBtuh	kW	75°F	80°F	85°F	kBtuh	kW	75°F	80°F	85°F	kBtuh	kW	75°F	80°F
63°F	640	27.2	1.02	0.67	0.8	0.93	25.5	1.19	0.68	0.81	0.96	23.9	1.38	0.69	0.83	0.98	22.1	1.61	0.7	0.86	1
	800	29	1.02	0.72	0.87	1	27.2	1.18	0.73	0.89	1	25.3	1.37	0.74	0.92	1	23.6	1.6	0.76	0.95	1
	960	30.3	1.01	0.77	0.94	1	28.5	1.17	0.79	0.97	1	26.7	1.37	0.81	1	1	25	1.58	0.83	1	1
67°F	640	29.3	1.01	0.54	0.65	0.76	27.5	1.18	0.54	0.65	0.78	25.7	1.37	0.53	0.66	0.79	24	1.59	0.54	0.68	0.82
	800	31.1	1.01	0.56	0.7	0.83	29.3	1.17	0.57	0.71	0.85	27.3	1.36	0.57	0.72	0.87	25.5	1.58	0.57	0.74	0.9
	960	32.4	1	0.58	0.74	0.9	30.5	1.16	0.6	0.76	0.93	28.5	1.35	0.59	0.78	0.96	26.5	1.57	0.61	0.8	0.99
71°F	640	31.3	1.01	0.41	0.52	0.62	29.6	1.17	0.41	0.52	0.63	27.8	1.36	0.4	0.53	0.64	25.8	1.58	0.39	0.53	0.65
	800	33.3	1	0.42	0.55	0.68	31.3	1.16	0.43	0.55	0.68	29.4	1.35	0.42	0.55	0.7	27.3	1.56	0.41	0.55	0.71
	960	34.6	1	0.43	0.57	0.72	32.6	1.15	0.44	0.59	0.73	30.5	1.34	0.42	0.58	0.75	28.4	1.55	0.42	0.59	0.77

3 TON HIGH EFFICIENCY SGH036H4E - (2ND STAGE)

Entering Wet Bulb Temperature	Total Air Volume	Outdoor Air Temperature Entering Outdoor Coil																			
		85°F					95°F					105°F					115°F				
		Total Cool Cap.	Comp. Motor Input	Sensible To Total Ratio (S/T)			Total Cool Cap.	Comp. Motor Input	Sensible To Total Ratio (S/T)			Total Cool Cap.	Comp. Motor Input	Sensible To Total Ratio (S/T)			Total Cool Cap.	Comp. Motor Input	Sensible To Total Ratio (S/T)		
				Dry Bulb					Dry Bulb					Dry Bulb					Dry Bulb		
		cfm	kBtuh	kW	75°F	80°F	85°F	kBtuh	kW	75°F	80°F	85°F	kBtuh	kW	75°F	80°F	85°F	kBtuh	kW	75°F	80°F
63°F	960	35.1	2.1	0.68	0.83	0.98	32.2	2.35	0.69	0.85	1	29.4	2.64	0.69	0.87	1	26.5	2.99	0.7	0.9	1
	1200	37.2	2.11	0.74	0.92	1	34.3	2.36	0.74	0.94	1	31.5	2.65	0.76	0.98	1	28.5	2.99	0.79	1	1
	1440	39	2.12	0.8	1	1	36.3	2.37	0.82	1	1	33.6	2.66	0.84	1	1	30.6	3	0.87	1	1
67°F	960	37.8	2.12	0.52	0.66	0.79	35	2.36	0.52	0.67	0.81	32.1	2.65	0.52	0.67	0.83	28.9	2.99	0.51	0.68	0.86
	1200	40.1	2.13	0.56	0.72	0.88	37.1	2.37	0.55	0.72	0.9	34.1	2.66	0.56	0.74	0.94	30.8	3	0.55	0.77	0.98
	1440	41.8	2.14	0.59	0.78	0.97	38.6	2.38	0.59	0.8	1	35.4	2.66	0.59	0.82	1	32.1	3.01	0.61	0.85	1
71°F	960	40.7	2.13	0.39	0.52	0.64	37.7	2.38	0.38	0.51	0.64	34.7	2.66	0.37	0.51	0.65	31.5	3.01	0.34	0.51	0.66
	1200	43	2.15	0.41	0.56	0.7	39.9	2.39	0.39	0.55	0.7	36.7	2.67	0.38	0.56	0.72	33.3	3.01	0.38	0.55	0.74
	1440	44.6	2.15	0.43	0.59	0.75	41.3	2.39	0.43	0.59	0.78	38	2.68	0.39	0.6	0.79	34.5	3.01	0.4	0.61	0.82

5 TON HIGH EFFICIENCY SGH060H4E - (1ST STAGE)

Entering Wet Bulb Temperature	Total Air Volume	Outdoor Air Temperature Entering Outdoor Coil																							
		65°F						75°F						85°F						95°F					
		Total Cool Cap.	Comp. Motor Input	Sensible To Total Ratio (S/T)			Total Cool Cap.	Comp. Motor Input	Sensible To Total Ratio (S/T)			Total Cool Cap.	Comp. Motor Input	Sensible To Total Ratio (S/T)			Total Cool Cap.	Comp. Motor Input	Sensible To Total Ratio (S/T)						
				Dry Bulb					Dry Bulb					Dry Bulb					Dry Bulb						
		cfm	kBtuh	kW	75°F	80°F	85°F	kBtuh	kW	75°F	80°F	85°F	kBtuh	kW	75°F	80°F	85°F	kBtuh	kW	75°F	80°F	85°F			
63°F	1070	45.1	1.66	0.68	0.81	0.94	42.5	1.98	0.69	0.82	0.96	39.9	2.33	0.7	0.84	0.98	37.1	2.71	0.71	0.86	1				
	1335	48	1.63	0.73	0.88	1	45.2	1.96	0.74	0.9	1	42.4	2.31	0.75	0.92	1	39.4	2.69	0.76	0.95	1				
	1600	50.1	1.61	0.78	0.95	1	47.3	1.94	0.79	0.97	1	44.4	2.3	0.81	0.99	1	41.6	2.68	0.83	1	1				
67°F	1070	48.4	1.63	0.54	0.66	0.77	45.8	1.96	0.53	0.66	0.78	43	2.31	0.54	0.67	0.8	40.1	2.69	0.54	0.68	0.82				
	1335	51.3	1.6	0.57	0.7	0.84	48.6	1.93	0.58	0.71	0.86	45.6	2.29	0.58	0.73	0.88	42.5	2.67	0.57	0.74	0.91				
	1600	53.5	1.58	0.6	0.75	0.91	50.6	1.91	0.6	0.76	0.93	47.7	2.27	0.6	0.78	0.95	44.4	2.66	0.61	0.8	0.99				
71°F	1070	51.9	1.59	0.42	0.53	0.63	49.1	1.93	0.41	0.52	0.64	46.3	2.28	0.41	0.53	0.64	43.3	2.67	0.4	0.53	0.65				
	1335	54.9	1.56	0.43	0.56	0.68	52	1.9	0.43	0.56	0.69	49	2.26	0.43	0.57	0.7	45.7	2.65	0.42	0.57	0.72				
	1600	57.2	1.54	0.45	0.59	0.73	54.1	1.88	0.45	0.59	0.74	50.8	2.24	0.43	0.59	0.75	47.5	2.63	0.44	0.6	0.77				

5 TON HIGH EFFICIENCY SGH060H4E - (2ND STAGE)

Entering Wet Bulb Temperature	Total Air Volume	Outdoor Air Temperature Entering Outdoor Coil																			
		85°F					95°F					105°F					115°F				
		Total Cool Cap.	Comp. Motor Input	Sensible To Total Ratio (S/T)			Total Cool Cap.	Comp. Motor Input	Sensible To Total Ratio (S/T)			Total Cool Cap.	Comp. Motor Input	Sensible To Total Ratio (S/T)			Total Cool Cap.	Comp. Motor Input	Sensible To Total Ratio (S/T)		
				Dry Bulb					Dry Bulb					Dry Bulb					Dry Bulb		
		cfm	kBtuh	kW	75°F	80°F	85°F	kBtuh	kW	75°F	80°F	85°F	kBtuh	kW	75°F	80°F	85°F	kBtuh	kW	75°F	80°F
63°F	1600	58.9	3.32	0.68	0.83	0.98	54.3	3.74	0.68	0.85	1	49.3	4.21	0.7	0.87	1	44.3	4.78	0.7	0.9	1
	2000	62.9	3.35	0.75	0.92	1	58	3.76	0.75	0.95	1	53	4.24	0.77	0.98	1	47.5	4.79	0.78	1	1
	2400	66.1	3.37	0.8	1	1	61.2	3.78	0.81	1	1	56.6	4.27	0.84	1	1	51.5	4.83	0.87	1	1
67°F	1600	64.1	3.35	0.52	0.66	0.79	59.1	3.77	0.52	0.66	0.81	54.1	4.25	0.51	0.67	0.83	48.8	4.8	0.49	0.67	0.85
	2000	68	3.38	0.57	0.72	0.88	62.9	3.8	0.56	0.73	0.91	57.6	4.28	0.56	0.74	0.93	51.9	4.83	0.55	0.76	0.97
	2400	71.2	3.4	0.6	0.78	0.96	65.6	3.82	0.6	0.79	0.99	60.2	4.3	0.6	0.81	1	54.4	4.85	0.6	0.84	1
71°F	1600	69.2	3.39	0.38	0.51	0.64	64.2	3.81	0.37	0.5	0.64	59.1	4.29	0.35	0.5	0.64	53.5	4.84	0.33	0.49	0.66
	2000	73.5	3.42	0.4	0.56	0.7	68.1	3.84	0.39	0.55	0.71	62.6	4.32	0.38	0.55	0.72	56.9	4.87	0.36	0.55	0.73
	2400	76.5	3.44	0.42	0.59	0.76	70.9	3.86	0.42	0.59	0.77	65.1	4.34	0.39	0.59	0.79	59.1	4.89	0.39	0.6	0.82

RATINGS

NOTE - For Temperatures and Capacities not shown in tables, see bulletin - Cooling Unit Rating Table Correction Factor Data in Miscellaneous Engineering Data section.

10 TON HIGH EFFICIENCY SGH120H4M (ONE COMPRESSOR OPERATING)

Entering Wet Bulb Temperature	Total Air Volume	Outdoor Air Temperature Entering Outdoor Coil																			
		65°F					75°F					85°F					95°F				
		Total Cool Cap.	Comp. Motor Input	Sensible To Total Ratio (S/T)			Total Cool Cap.	Comp. Motor Input	Sensible To Total Ratio (S/T)			Total Cool Cap.	Comp. Motor Input	Sensible To Total Ratio (S/T)			Total Cool Cap.	Comp. Motor Input	Sensible To Total Ratio (S/T)		
				Dry Bulb					Dry Bulb					Dry Bulb					Dry Bulb		
cfm	kBtuh	kW	75°F	80°F	85°F	kBtuh	kW	75°F	80°F	85°F	kBtuh	kW	75°F	80°F	85°F	kBtuh	kW	75°F	80°F	85°F	
63°F	2000	69.2	2.66	0.75	0.9	1	65	2.99	0.76	0.92	1	60.7	3.36	0.77	0.94	1	56.1	3.8	0.78	0.96	1
	2400	72.4	2.68	0.8	0.97	1	67.9	3.01	0.81	0.99	1	63.6	3.38	0.83	1	1	59.5	3.82	0.85	1	1
	2800	75.3	2.7	0.85	1	1	71.3	3.03	0.86	1	1	67.1	3.41	0.88	1	1	62.7	3.84	0.91	1	1
67°F	2000	74.3	2.69	0.59	0.73	0.87	69.9	3.02	0.58	0.73	0.88	65.3	3.39	0.58	0.75	0.9	60.7	3.82	0.58	0.76	0.93
	2400	77.5	2.71	0.62	0.78	0.93	72.9	3.04	0.62	0.79	0.96	68.1	3.41	0.62	0.8	0.98	63.2	3.84	0.62	0.82	1
	2800	79.9	2.73	0.65	0.83	0.99	75.2	3.05	0.65	0.84	1	70.2	3.43	0.66	0.86	1	65.1	3.85	0.66	0.89	1
71°F	2000	79.2	2.73	0.44	0.57	0.71	74.6	3.05	0.43	0.57	0.71	69.9	3.42	0.42	0.57	0.72	65	3.85	0.41	0.58	0.73
	2400	82.6	2.75	0.45	0.61	0.75	77.8	3.07	0.45	0.61	0.77	72.9	3.44	0.44	0.61	0.78	67.9	3.87	0.43	0.62	0.8
	2800	85.3	2.77	0.47	0.64	0.8	80.3	3.09	0.46	0.64	0.82	75.2	3.46	0.45	0.65	0.84	70	3.89	0.45	0.66	0.86

10 TON HIGH EFFICIENCY SGH120H4M (ALL COMPRESSOR OPERATING)

Entering Wet Bulb Temperature	Total Air Volume	Outdoor Air Temperature Entering Outdoor Coil																			
		85°F					95°F					105°F					115°F				
		Total Cool Cap.	Comp. Motor Input	Sensible To Total Ratio (S/T)			Total Cool Cap.	Comp. Motor Input	Sensible To Total Ratio (S/T)			Total Cool Cap.	Comp. Motor Input	Sensible To Total Ratio (S/T)			Total Cool Cap.	Comp. Motor Input	Sensible To Total Ratio (S/T)		
				Dry Bulb					Dry Bulb					Dry Bulb					Dry Bulb		
cfm	kBtuh	kW	75°F	80°F	85°F	kBtuh	kW	75°F	80°F	85°F	kBtuh	kW	75°F	80°F	85°F	kBtuh	kW	75°F	80°F	85°F	
63°F	3200	117.4	6.72	0.72	0.86	0.98	109	7.58	0.73	0.87	1	100.2	8.59	0.74	0.89	1	91.1	9.72	0.73	0.91	1
	4000	123.6	6.75	0.78	0.93	1	115	7.62	0.78	0.95	1	106.2	8.62	0.8	0.97	1	96.7	9.76	0.82	1	1
	4800	128.9	6.78	0.83	0.99	1	120.3	7.65	0.84	1	1	111.7	8.66	0.86	1	1	102.4	9.8	0.89	1	1
67°F	3200	125.4	6.76	0.56	0.7	0.83	116.6	7.63	0.55	0.71	0.84	107.6	8.63	0.55	0.7	0.86	97.7	9.76	0.55	0.72	0.88
	4000	131.7	6.8	0.59	0.74	0.9	122.5	7.67	0.59	0.76	0.92	112.8	8.66	0.59	0.77	0.94	102.6	9.8	0.6	0.79	0.97
	4800	136.2	6.83	0.62	0.8	0.97	126.6	7.69	0.64	0.81	0.99	116.5	8.69	0.64	0.85	1	106	9.83	0.65	0.88	1
71°F	3200	133.3	6.81	0.41	0.55	0.67	124.1	7.67	0.4	0.55	0.68	115	8.68	0.38	0.54	0.69	105	9.83	0.37	0.54	0.69
	4000	140	6.85	0.43	0.58	0.73	130.6	7.72	0.42	0.58	0.74	120.6	8.71	0.41	0.59	0.76	110.1	9.86	0.4	0.6	0.77
	4800	145	6.88	0.44	0.61	0.78	135	7.74	0.43	0.62	0.8	125	8.75	0.42	0.62	0.82	114	9.9	0.41	0.63	0.84

RATINGS

NOTE - For Temperatures and Capacities not shown in tables, see bulletin - Cooling Unit Rating Table Correction Factor Data in Miscellaneous Engineering Data section.

20 TON HIGH EFFICIENCY SGH240H4M (ONE COMPRESSOR OPERATING)

Entering Wet Bulb Temperature	Total Air Volume	Outdoor Air Temperature Entering Outdoor Coil																			
		65°F					75°F					85°F					95°F				
		Total Cool Cap.	Comp. Motor Input	Sensible To Total Ratio (S/T)			Total Cool Cap.	Comp. Motor Input	Sensible To Total Ratio (S/T)			Total Cool Cap.	Comp. Motor Input	Sensible To Total Ratio (S/T)			Total Cool Cap.	Comp. Motor Input	Sensible To Total Ratio (S/T)		
				Dry Bulb					Dry Bulb					Dry Bulb					Dry Bulb		
cfm	kBtuh	kW	75°F	80°F	85°F	kBtuh	kW	75°F	80°F	85°F	kBtuh	kW	75°F	80°F	85°F	kBtuh	kW	75°F	80°F	85°F	
63°F	1600	62.2	2.56	0.71	0.83	0.94	60.2	2.9	0.72	0.84	0.96	58	3.28	0.73	0.86	0.98	55.5	3.71	0.74	0.88	1
	2000	66	2.59	0.75	0.88	1	63.7	2.93	0.76	0.9	1	61.3	3.31	0.78	0.92	1	58.6	3.74	0.79	0.94	1
	2400	68.8	2.61	0.79	0.93	1	66.3	2.94	0.8	0.95	1	63.7	3.32	0.81	0.97	1	60.9	3.75	0.83	0.99	1
67°F	1600	65.4	2.58	0.57	0.69	0.8	63.2	2.92	0.57	0.7	0.81	60.8	3.3	0.58	0.71	0.83	58.2	3.73	0.59	0.72	0.84
	2000	69.1	2.61	0.59	0.73	0.85	66.6	2.95	0.6	0.74	0.87	63.9	3.32	0.61	0.75	0.89	61.2	3.75	0.62	0.77	0.91
	2400	71.7	2.64	0.62	0.76	0.9	69	2.96	0.63	0.78	0.92	66.3	3.34	0.63	0.79	0.94	63.2	3.76	0.64	0.81	0.97
71°F	1600	68.6	2.61	0.43	0.55	0.67	66	2.94	0.43	0.56	0.67	63.5	3.32	0.44	0.57	0.68	61.1	3.75	0.44	0.57	0.7
	2000	72.6	2.64	0.44	0.58	0.71	69.7	2.97	0.45	0.59	0.72	67	3.34	0.44	0.6	0.73	64.2	3.77	0.45	0.61	0.75
	2400	75.3	2.66	0.44	0.61	0.74	72.6	2.99	0.46	0.62	0.76	69.8	3.36	0.47	0.62	0.77	66.7	3.79	0.46	0.63	0.79

20 TON HIGH EFFICIENCY SGH240H4M (TWO COMPRESSOR OPERATING)

Entering Wet Bulb Temperature	Total Air Volume	Outdoor Air Temperature Entering Outdoor Coil																			
		65°F					75°F					85°F					95°F				
		Total Cool Cap.	Comp. Motor Input	Sensible To Total Ratio (S/T)			Total Cool Cap.	Comp. Motor Input	Sensible To Total Ratio (S/T)			Total Cool Cap.	Comp. Motor Input	Sensible To Total Ratio (S/T)			Total Cool Cap.	Comp. Motor Input	Sensible To Total Ratio (S/T)		
				Dry Bulb					Dry Bulb					Dry Bulb					Dry Bulb		
cfm	kBtuh	kW	75°F	80°F	85°F	kBtuh	kW	75°F	80°F	85°F	kBtuh	kW	75°F	80°F	85°F	kBtuh	kW	75°F	80°F	85°F	
63°F	3200	126.9	5.13	0.71	0.83	0.94	122.7	5.81	0.72	0.84	0.96	117.9	6.58	0.73	0.86	0.98	112.9	7.45	0.74	0.87	0.99
	4000	134.3	5.19	0.75	0.88	1	129.4	5.86	0.76	0.9	1	124.5	6.62	0.77	0.92	1	119.2	7.48	0.79	0.94	1
	4800	139.8	5.23	0.78	0.93	1	134.8	5.89	0.8	0.95	1	129.5	6.65	0.81	0.97	1	123.9	7.51	0.83	0.99	1
67°F	3200	133.1	5.18	0.56	0.69	0.8	128.6	5.85	0.57	0.69	0.81	123.7	6.61	0.58	0.71	0.82	118.4	7.47	0.58	0.72	0.84
	4000	140.6	5.23	0.59	0.73	0.85	135.6	5.9	0.6	0.74	0.87	130.2	6.65	0.61	0.75	0.88	124.7	7.52	0.62	0.76	0.9
	4800	146.1	5.27	0.62	0.76	0.9	140.6	5.93	0.62	0.78	0.92	134.9	6.68	0.63	0.79	0.94	128.7	7.53	0.64	0.81	0.96
71°F	3200	139.4	5.23	0.43	0.55	0.66	134.4	5.89	0.43	0.56	0.67	129.2	6.65	0.44	0.56	0.68	124.3	7.51	0.44	0.57	0.69
	4000	147.4	5.28	0.44	0.57	0.7	141.8	5.94	0.45	0.58	0.71	136.3	6.69	0.45	0.59	0.73	130.4	7.55	0.45	0.6	0.74
	4800	152.9	5.32	0.44	0.6	0.74	147.3	5.97	0.46	0.61	0.76	141.5	6.72	0.47	0.62	0.77	135.3	7.57	0.47	0.63	0.79

20 TON HIGH EFFICIENCY SGH240H4M (THREE COMPRESSOR OPERATING)

Entering Wet Bulb Temperature	Total Air Volume	Outdoor Air Temperature Entering Outdoor Coil																			
		85°F					95°F					105°F					115°F				
		Total Cool Cap.	Comp. Motor Input	Sensible To Total Ratio (S/T)			Total Cool Cap.	Comp. Motor Input	Sensible To Total Ratio (S/T)			Total Cool Cap.	Comp. Motor Input	Sensible To Total Ratio (S/T)			Total Cool Cap.	Comp. Motor Input	Sensible To Total Ratio (S/T)		
				Dry Bulb					Dry Bulb					Dry Bulb					Dry Bulb		
cfm	kBtuh	kW	75°F	80°F	85°F	kBtuh	kW	75°F	80°F	85°F	kBtuh	kW	75°F	80°F	85°F	kBtuh	kW	75°F	80°F	85°F	
63°F	4800	169.1	10.11	0.68	0.82	0.91	155.9	11.44	0.67	0.83	0.92	142.3	12.95	0.68	0.84	0.93	127.8	14.69	0.69	0.85	0.95
	6000	184.9	10.18	0.73	0.87	0.96	171.1	11.51	0.75	0.88	0.97	156.7	13.03	0.76	0.89	0.98	141.5	14.77	0.78	0.91	1
	7200	197.2	10.24	0.8	0.91	0.99	182.8	11.57	0.81	0.92	1	167.9	13.09	0.82	0.93	1	152.3	14.83	0.83	0.95	1
67°F	4800	184.9	10.18	0.51	0.65	0.79	170.6	11.5	0.5	0.66	0.81	156.1	13.02	0.49	0.66	0.82	140.3	14.76	0.48	0.67	0.83
	6000	199	10.25	0.54	0.71	0.86	183.9	11.56	0.54	0.72	0.86	167.9	13.08	0.54	0.74	0.87	151.1	14.82	0.54	0.76	0.89
	7200	209.3	10.29	0.58	0.77	0.89	193.7	11.61	0.58	0.78	0.9	177.3	13.13	0.59	0.8	0.92	160.3	14.86	0.59	0.8	0.93
71°F	4800	200.7	10.25	0.36	0.5	0.63	186.2	11.57	0.34	0.49	0.63	170.9	13.09	0.33	0.49	0.64	154.7	14.83	0.3	0.48	0.65
	6000	215.5	10.32	0.38	0.54	0.69	199.9	11.64	0.37	0.54	0.7	184.1	13.16	0.35	0.53	0.71	166.7	14.91	0.33	0.54	0.73
	7200	225.6	10.37	0.4	0.58	0.75	210.3	11.69	0.39	0.58	0.77	193.3	13.21	0.38	0.58	0.78	174.7	14.95	0.37	0.59	0.79

20 TON HIGH EFFICIENCY SGH240H4M (ALL COMPRESSOR OPERATING)

Entering Wet Bulb Temperature	Total Air Volume	Outdoor Air Temperature Entering Outdoor Coil																			
		85°F					95°F					105°F					115°F				
		Total Cool Cap.	Comp. Motor Input	Sensible To Total Ratio (S/T)			Total Cool Cap.	Comp. Motor Input	Sensible To Total Ratio (S/T)			Total Cool Cap.	Comp. Motor Input	Sensible To Total Ratio (S/T)			Total Cool Cap.	Comp. Motor Input	Sensible To Total Ratio (S/T)		
				Dry Bulb					Dry Bulb					Dry Bulb					Dry Bulb		
cfm	kBtuh	kW	75°F	80°F	85°F	kBtuh	kW	75°F	80°F	85°F	kBtuh	kW	75°F	80°F	85°F	kBtuh	kW	75°F	80°F	85°F	
63°F	6400	228.6	13.54	0.66	0.82	0.96	209.7	15.31	0.67	0.84	0.98	190.8	17.33	0.68	0.86	1	171.2	19.64	0.68	0.88	1
	8000	246.6	13.63	0.72	0.9	1	228	15.4	0.74	0.92	1	208.4	17.42	0.75	0.95	1	188	19.75	0.77	0.98	1
	9600	262	13.7	0.79	0.97	1	242.8	15.47	0.81	0.99	1	223.2	17.5	0.83	1	1	203	19.83	0.85	1	1
67°F	6400	250.6	13.65	0.5	0.64	0.79	231.4	15.41	0.49	0.65	0.8	211.2	17.43	0.48	0.66	0.82	189.7	19.75	0.48	0.66	0.85
	8000	268.4	13.73	0.54	0.71	0.87	247.9	15.49	0.54	0.72	0.89	226.6	17.51	0.54	0.73	0.92	203.1	19.82	0.54	0.76	0.95
	9600	281.2	13.79	0.58	0.77	0.94	259.8	15.55	0.58	0.78	0.96	237	17.56	0.59	0.8	0.99	213.1	19.88	0.59	0.83	1
71°F	6400	272.7	13.74	0.36	0.49	0.62	253.1	15.51	0.34	0.49	0.63	232.6	17.53	0.32	0.48	0.63	210.4	19.86	0.3	0.47	0.65
	8000	291.3	13.83	0.37	0.53	0.69	270.1	15.59	0.36	0.53	0.69	247.5	17.62	0.35	0.54	0.71	223.5	19.94	0.33	0.54	0.73
	9600	304.7	13.89	0.39	0.57	0.75	282	15.65	0.38	0.58	0.76	258.2	17.68	0.38	0.59	0.78	233.7	20.01	0.36	0.59	0.81

HUMIDITROL® DEHUMIDIFICATION SYSTEM RATINGS

3 TON HIGH EFFICIENCY SGH036H4E WITH HUMIDITROL® OPERATING - DIRECT DRIVE

Entering Wet Bulb Temperature	Total Air Volume	Outdoor Air Temperature Entering Outdoor Coil																			
		65°F					75°F					85°F					95°F				
		Total Cool Cap.	Comp. Motor Input	Sensible To Total Ratio (S/T)			Total Cool Cap.	Comp. Motor Input	Sensible To Total Ratio (S/T)			Total Cool Cap.	Comp. Motor Input	Sensible To Total Ratio (S/T)			Total Cool Cap.	Comp. Motor Input	Sensible To Total Ratio (S/T)		
				Dry Bulb					Dry Bulb					Dry Bulb					Dry Bulb		
		cfm	kBtuh	kW	75°F	80°F	85°F	kBtuh	kW	75°F	80°F	85°F	kBtuh	kW	75°F	80°F	85°F	kBtuh	kW	75°F	80°F
63°F	640	24.6	1.6	0.45	0.59	0.72	20.1	1.8	0.41	0.53	0.71	15.7	2.0	0.31	0.48	0.71	11.3	2.2	0.16	0.43	0.70
	800	26.6	1.6	0.48	0.63	0.78	21.5	1.8	0.44	0.60	0.80	16.5	2.0	0.35	0.56	0.83	11.4	2.2	0.20	0.53	0.85
	960	28.6	1.7	0.51	0.68	0.84	22.9	1.8	0.46	0.66	0.86	17.2	2.0	0.38	0.66	0.93	11.5	2.2	0.24	0.62	1.00
67°F	640	28.5	1.7	0.35	0.46	0.58	24.1	1.9	0.24	0.39	0.54	19.6	2.1	0.16	0.33	0.36	15.2	2.3	0.04	0.26	0.48
	800	31.1	1.7	0.36	0.47	0.62	25.9	1.9	0.26	0.42	0.60	20.7	2.1	0.17	0.36	0.40	15.4	2.3	0.05	0.25	0.57
	960	33.8	1.7	0.38	0.52	0.65	27.7	1.9	0.31	0.48	0.64	21.7	2.1	0.22	0.44	0.63	15.7	2.3	0.05	0.36	0.61
71°F	640	32.5	1.7	0.24	0.34	0.43	28.0	1.9	0.13	0.25	0.37	23.6	2.1	0.09	0.17	0.25	19.1	2.3	-0.08	0.09	0.26
	800	35.7	1.7	0.24	0.35	0.46	30.3	1.9	0.14	0.28	0.41	24.9	2.1	0.07	0.20	0.32	19.5	2.3	-0.11	0.09	0.30
	960	38.9	1.7	0.24	0.37	0.49	32.5	1.9	0.16	0.30	0.44	26.2	2.1	0.05	0.23	0.40	19.8	2.3	-0.14	0.10	0.33

5 TON HIGH EFFICIENCY SGH060H4E WITH HUMIDITROL® OPERATING - DIRECT DRIVE

Entering Wet Bulb Temperature	Total Air Volume	Outdoor Air Temperature Entering Outdoor Coil																			
		65°F					75°F					85°F					95°F				
		Total Cool Cap.	Comp. Motor Input	Sensible To Total Ratio (S/T)			Total Cool Cap.	Comp. Motor Input	Sensible To Total Ratio (S/T)			Total Cool Cap.	Comp. Motor Input	Sensible To Total Ratio (S/T)			Total Cool Cap.	Comp. Motor Input	Sensible To Total Ratio (S/T)		
				Dry Bulb					Dry Bulb					Dry Bulb					Dry Bulb		
		cfm	kBtuh	kW	75°F	80°F	85°F	kBtuh	kW	75°F	80°F	85°F	kBtuh	kW	75°F	80°F	85°F	kBtuh	kW	75°F	80°F
63°F	1080	41.9	2.8	0.48	0.62	0.75	34.9	3.0	0.45	0.60	0.75	28.8	3.3	0.38	0.56	0.75	22.1	3.7	0.27	0.52	0.76
	1350	44.8	2.8	0.52	0.66	0.81	37.1	3.1	0.48	0.66	0.83	29.8	3.4	0.43	0.64	0.85	22.3	3.7	0.32	0.60	0.88
	1620	47.7	2.9	0.55	0.71	0.87	39.3	3.1	0.52	0.72	0.91	30.8	3.4	0.48	0.72	0.96	22.5	3.8	0.37	0.68	1.00
67°F	1080	47.9	2.8	0.35	0.46	0.58	41.1	3.1	0.29	0.43	0.56	34.7	3.4	0.22	0.38	0.54	27.9	3.8	0.10	0.30	0.49
	1350	50.7	2.9	0.37	0.50	0.62	43.4	3.1	0.31	0.47	0.62	36.0	3.4	0.23	0.42	0.61	28.2	3.8	0.10	0.34	0.58
	1620	53.6	3.0	0.38	0.53	0.67	45.6	3.2	0.33	0.50	0.68	37.4	3.5	0.24	0.46	0.68	28.5	3.8	0.10	0.39	0.67
71°F	1080	53.4	2.9	0.24	0.35	0.45	46.6	3.2	0.18	0.30	0.41	40.3	3.5	0.10	0.24	0.38	33.3	3.9	-0.02	0.14	0.30
	1350	56.7	3.0	0.25	0.36	0.48	49.8	3.2	0.18	0.31	0.45	42.4	3.5	0.09	0.25	0.41	34.2	3.9	-0.04	0.16	0.35
	1620	60.0	3.0	0.25	0.38	0.51	52.9	3.3	0.18	0.33	0.49	44.5	3.6	0.08	0.27	0.45	35.0	3.9	-0.06	0.17	0.40

10 TON HIGH EFFICIENCY SGH0120H4M WITH HUMIDITROL® OPERATING (1ST STAGE) - MSAV®

Entering Wet Bulb Temperature	Total Air Volume	Outdoor Air Temperature Entering Outdoor Coil																			
		65°F					75°F					85°F					95°F				
		Total Cool Cap.	Comp. Motor Input	Sensible To Total Ratio (S/T)			Total Cool Cap.	Comp. Motor Input	Sensible To Total Ratio (S/T)			Total Cool Cap.	Comp. Motor Input	Sensible To Total Ratio (S/T)			Total Cool Cap.	Comp. Motor Input	Sensible To Total Ratio (S/T)		
				Dry Bulb					Dry Bulb					Dry Bulb					Dry Bulb		
		cfm	kBtuh	kW	75°F	80°F	85°F	kBtuh	kW	75°F	80°F	85°F	kBtuh	kW	75°F	80°F	85°F	kBtuh	kW	75°F	80°F
63°F	2000	46.6	2.5	.61	.78	.96	36.6	2.8	.51	.79	.97	26.6	3.1	.42	.80	.99	16.6	3.4	.32	.81	1.00
	2400	47.9	2.6	.66	.87	.98	37.4	2.8	.56	.88	.99	26.9	3.1	.47	.89	.99	16.3	3.4	.38	.91	1.00
	2800	49.1	2.6	.70	.95	1.00	38.1	2.8	.62	.97	1.00	27.1	3.1	.53	.98	1.00	16.1	3.4	.44	1.00	1.00
67°F	2000	53.2	2.6	.42	.59	.76	43.3	2.9	.30	.55	.74	33.4	3.2	.17	.50	.73	23.5	3.5	.04	.45	.71
	2400	54.5	2.6	.45	.65	.80	44.1	2.9	.32	.60	.78	33.6	3.2	.19	.56	.76	23.2	3.5	.06	.51	.75
	2800	55.8	2.7	.47	.70	.83	44.8	2.9	.34	.66	.82	33.8	3.2	.20	.61	.80	22.9	3.5	.07	.57	.79
71°F	2000	59.7	2.7	.24	.40	.57	49.9	3.0	.08	.30	.52	40.2	3.3	-.08	.19	.47	30.4	3.5	-.24	.09	.41
	2400	61.1	2.7	.24	.43	.61	50.7	3.0	.07	.32	.57	40.4	3.3	-.10	.22	.53	30.0	3.5	-.27	.11	.50
	2800	62.5	2.7	.25	.45	.66	51.6	3.0	.06	.35	.63	40.6	3.3	-.12	.24	.60	29.6	3.5	-.30	.14	.58

10 TON HIGH EFFICIENCY SGH120H4E WITH HUMIDITROL® OPERATING (2ND STAGE) - MSAV®

Entering Wet Bulb Temperature	Total Air Volume	Outdoor Air Temperature Entering Outdoor Coil																			
		65°F					75°F					85°F					95°F				
		Total Cool Cap.	Comp. Motor Input	Sensible To Total Ratio (S/T)			Total Cool Cap.	Comp. Motor Input	Sensible To Total Ratio (S/T)			Total Cool Cap.	Comp. Motor Input	Sensible To Total Ratio (S/T)			Total Cool Cap.	Comp. Motor Input	Sensible To Total Ratio (S/T)		
				Dry Bulb					Dry Bulb					Dry Bulb					Dry Bulb		
		cfm	kBtuh	kW	75°F	80°F	85°F	kBtuh	kW	75°F	80°F	85°F	kBtuh	kW	75°F	80°F	85°F	kBtuh	kW	75°F	80°F
63°F	3200	101.2	5.2	.62	.78	.94	86.7	5.9	.59	.78	.96	72.2	6.5	.56	.79	.98	57.6	7.2	.52	.79	1.00
	4000	104.9	5.2	.67	.83	.97	89.2	5.9	.65	.85	.98	73.6	6.6	.63	.86	.99	58.0	7.2	.60	.87	1.00
	4800	108.5	5.3	.72	.89	1.00	91.8	5.9	.71	.91	1.00	75.1	6.6	.70	.94	1.00	58.3	7.2	.69	.96	1.00
67°F	3200	112.4	5.3	.47	.61	.76	98.1	6.0	.42	.59	.76	83.8	6.6	.37	.57	.76	69.5	7.3	.32	.55	.76
	4000	116.5	5.4	.49	.65	.80	100.9	6.0	.45	.64	.80	85.3	6.7	.40	.63	.80	69.8	7.3	.36	.61	.80
	4800	120.5	5.4	.52	.69	.84	103.7	6.0	.48	.69	.84	86.9	6.7	.44	.68	.84	70.0	7.3	.40	.68	.84
71°F	3200	123.5	5.4	.31	.45	.58	109.5	6.1	.24	.40	.56	95.4	6.7	.18	.36	.54	81.4	7.4	.11	.32	.52
	4000	128.0	5.5	.31	.47	.64	112.5	6.1	.25	.43	.62	97.0	6.8	.18	.39	.61	81.6	7.4	.11	.35	.60
	4800	132.5	5.5	.32	.50	.69	115.6	6.2	.25	.47	.68	98.7	6.8	.18	.43	.68	81.7	7.4	.11	.39	.68

HUMIDITROL® DEHUMIDIFICATION SYSTEM RATINGS

20 TON HIGH EFFICIENCY SGH240H4E WITH HUMIDITROL® OPERATING (1ST STAGE) - MSAV®

Entering Wet Bulb Temperature	Total Air Volume	Outdoor Air Temperature Entering Outdoor Coil																							
		65°F						75°F						85°F						95°F					
		Total Cool Cap.	Comp. Motor Input	Sensible To Total Ratio (S/T)			Total Cool Cap.	Comp. Motor Input	Sensible To Total Ratio (S/T)			Total Cool Cap.	Comp. Motor Input	Sensible To Total Ratio (S/T)			Total Cool Cap.	Comp. Motor Input	Sensible To Total Ratio (S/T)						
				Dry Bulb					Dry Bulb					Dry Bulb					Dry Bulb						
		cfm	kBtuh	kW	75°F	80°F	85°F	kBtuh	kW	75°F	80°F	85°F	kBtuh	kW	75°F	80°F	85°F	kBtuh	kW	75°F	80°F	85°F			
63°F	3200	75.3	5.5	0.49	0.71	0.92	60.9	6.0	0.42	0.65	0.88	44.2	6.6	0.28	0.58	0.88	25.6	7.2	0.01	0.49	0.88				
	4000	79.1	5.6	0.57	0.76	0.95	62.6	6.0	0.50	0.72	0.94	44.7	6.6	0.37	0.66	0.94	27.1	7.3	0.06	0.50	0.94				
	4800	82.9	5.6	0.64	0.81	0.99	64.2	6.1	0.59	0.79	1.00	45.2	6.6	0.47	0.74	1.00	28.6	7.3	0.11	0.51	1.00				
67°F	3200	87.5	5.7	0.30	0.49	0.67	69.5	6.1	0.20	0.43	0.66	51.0	6.7	0.03	0.32	0.62	30.4	7.4	0.32	0.43	0.55				
	4000	88.2	5.7	0.33	0.55	0.75	69.9	6.2	0.22	0.50	0.75	51.4	6.7	0.03	0.39	0.74	32.2	7.4	0.43	0.53	0.71				
	4800	94.1	5.8	0.36	0.59	0.82	72.9	6.2	0.25	0.55	0.85	52.7	6.7	0.03	0.44	0.85	37.3	7.4	0.55	0.70	0.86				
71°F	3200	101.8	5.8	0.14	0.31	0.47	84.3	6.3	0.02	0.22	0.42	66.9	6.9	0.17	0.25	0.34	45.1	7.5	0.49	0.34	0.20				
	4000	105.0	5.9	0.15	0.34	0.53	86.5	6.3	0.02	0.25	0.48	67.1	6.9	0.19	0.30	0.41	46.8	7.5	0.57	0.42	0.27				
	4800	108.1	5.9	0.15	0.36	0.58	88.6	6.3	0.02	0.28	0.54	67.3	6.9	0.21	0.35	0.48	48.5	7.6	0.65	0.50	0.34				

20 TON HIGH EFFICIENCY SGH240H4E WITH HUMIDITROL® OPERATING (2ND STAGE) - MSAV®

Entering Wet Bulb Temperature	Total Air Volume	Outdoor Air Temperature Entering Outdoor Coil																							
		65°F						75°F						85°F						95°F					
		Total Cool Cap.	Comp. Motor Input	Sensible To Total Ratio (S/T)			Total Cool Cap.	Comp. Motor Input	Sensible To Total Ratio (S/T)			Total Cool Cap.	Comp. Motor Input	Sensible To Total Ratio (S/T)			Total Cool Cap.	Comp. Motor Input	Sensible To Total Ratio (S/T)						
				Dry Bulb					Dry Bulb					Dry Bulb					Dry Bulb						
		cfm	kBtuh	kW	75°F	80°F	85°F	kBtuh	kW	75°F	80°F	85°F	kBtuh	kW	75°F	80°F	85°F	kBtuh	kW	75°F	80°F	85°F			
63°F	6400	189.6	10.5	0.57	0.74	0.91	164.1	11.6	0.55	0.73	0.91	138.0	13.0	0.51	0.70	0.90	108.6	14.5	0.46	0.70	0.94				
	8000	198.4	10.7	0.62	0.79	0.95	172.4	11.7	0.61	0.78	0.94	142.9	13.0	0.58	0.76	0.93	108.8	14.5	0.57	0.76	0.95				
	9600	207.1	10.9	0.68	0.83	0.99	180.6	11.7	0.67	0.83	0.98	147.8	13.0	0.66	0.81	0.97	108.9	14.5	0.67	0.82	0.97				
67°F	6400	212.2	10.7	0.39	0.55	0.72	183.7	11.9	0.34	0.53	0.71	155.8	13.2	0.28	0.49	0.71	123.2	14.8	0.18	0.45	0.72				
	8000	222.1	10.8	0.42	0.61	0.78	190.2	11.9	0.37	0.60	0.78	158.3	13.2	0.30	0.57	0.78	124.5	14.7	0.21	0.53	0.77				
	9600	226.1	11.0	0.44	0.65	0.85	194.3	11.9	0.40	0.63	0.85	160.3	13.2	0.33	0.59	0.84	122.8	14.7	0.23	0.53	0.83				
71°F	6400	235.1	11.0	0.24	0.39	0.54	205.6	12.2	0.18	0.35	0.51	175.5	13.5	0.10	0.29	0.49	145.0	15.0	0.02	0.23	0.45				
	8000	242.3	11.1	0.24	0.41	0.59	213.1	12.1	0.18	0.38	0.57	179.6	13.4	0.09	0.32	0.55	145.2	14.9	0.05	0.28	0.52				
	9600	249.5	11.3	0.24	0.44	0.64	220.6	12.1	0.18	0.41	0.63	183.7	13.3	0.08	0.35	0.62	145.4	14.8	0.08	0.33	0.59				

BLOWER DATA

DIRECT DRIVE | 3 - 5 TON

SGH036H / SGH060H BLOWER PERFORMANCE

NOTE - Blower Table Includes Resistance For Base Unit With Gas Heat, Wet Indoor Coil And Air Filters In Place.

MINIMUM / MAXIMUM AIR VOLUME REQUIRED FOR USE WITH SGH036H MODELS WITH MEDIUM 2 STAGE HEAT OPTION - 1475 CFM

Air Volume cfm	EXTERNAL STATIC PRESSURE - In. w.g.																												
	0.1		0.2		0.3		0.4		0.5		0.6		0.7		0.8		0.9		1.0		1.1		1.2		1.3		1.4		
	RPM	Watts	RPM	Watts	RPM	Watts	RPM	Watts	RPM	Watts	RPM	Watts	RPM	Watts	RPM	Watts	RPM	Watts	RPM	Watts	RPM	Watts	RPM	Watts	RPM	Watts	RPM	Watts	RPM
900	1296	48	1351	79	1408	110	1465	139	1523	167	1580	194	1636	220	1692	244	1746	268	1798	291	1849	312	1898	334	1945	355	1990	375	
1000	1394	95	1449	125	1505	154	1562	182	1618	208	1674	234	1729	258	1782	282	1834	305	1884	328	1933	350	1980	372	2025	394	2069	417	
1100	1495	141	1550	170	1606	197	1661	223	1717	249	1771	273	1824	297	1875	321	1925	344	1973	367	2020	390	2065	414	2108	438	2152	464	
1200	1599	186	1654	213	1709	239	1764	264	1818	289	1870	313	1921	337	1970	362	2018	386	2064	411	2109	436	2153	461	2195	487	2238	516	
1300	1707	230	1762	256	1816	281	1869	306	1921	331	1971	356	2020	381	2068	407	2114	433	2158	460	2202	486	2244	513	2285	542	2327	573	
1400	1819	273	1873	299	1926	324	1977	350	2027	377	2075	404	2122	431	2168	459	2212	486	2255	515	2297	543	2338	572	2378	602	2419	635	
1500	1935	318	1987	345	2037	372	2086	400	2134	429	2180	458	2225	487	2269	517	2312	546	2354	576	2395	607	2435	637	2474	669	2513	704	
1600	2052	368	2102	397	2150	427	2197	457	2242	488	2287	519	2331	550	2373	582	2415	613	2455	645	2495	678	2534	710	2572	744	2610	779	
1700	2169	426	2217	457	2263	489	2308	521	2352	554	2395	587	2437	621	2479	654	2519	688	2558	722	2597	757	2635	791	2672	827	2708	862	
1800	2286	491	2332	524	2377	558	2420	593	2463	628	2505	664	2545	700	2585	735	2624	771	2663	808	2700	844	2737	882	2773	919	2808	956	
1900	2404	565	2448	600	2491	637	2533	674	2574	711	2615	749	2654	787	2693	825	2731	863	2768	902	2805	941	2841	980	2875	1020	2910	1058	
2000	2522	648	2564	685	2606	724	2647	764	2687	803	2726	843	2764	883	2802	924	2839	964	2875	1004	2910	1045	2945	1085	2979	1125	3013	1163	
2100	2640	739	2681	779	2722	821	2761	863	2800	904	2838	946	2875	988	2911	1029	2947	1071	2982	1111	3017	1152	---	---	---	---	---	---	
2200	2759	840	2799	884	2838	927	2876	970	2913	1013	2950	1055	2986	1097	3021	1139	---	---	---	---	---	---	---	---	---	---	---	---	
2300	2878	950	2916	995	2954	1039	2991	1082	3027	1125	---	---	---	---	---	---	---	---	---	---	---	---	---	---	---	---	---	---	
2400	2997	1066	3033	1110	---	---	---	---	---	---	---	---	---	---	---	---	---	---	---	---	---	---	---	---	---	---	---	---	
2500	---	---	---	---	---	---	---	---	---	---	---	---	---	---	---	---	---	---	---	---	---	---	---	---	---	---	---	---	

BLOWER DATA

BELT DRIVE | 10 TON

SGH120HM BLOWER PERFORMANCE

NOTE - Blower Table Includes Resistance For Base Unit With Gas Heat, Wet Indoor Coil And Air Filters In Place. See Blower Motor / Drive Kit Table on page 38 for Motor HP and Drive Kit RPM Ranges Available.

Air Volume cfm	EXTERNAL STATIC PRESSURE - In. w.g.																									
	0.1		0.2		0.3		0.4		0.5		0.6		0.7		0.8		0.9		1.0		1.1		1.2		1.3	
	RPM	BHP	RPM	BHP	RPM	BHP	RPM	BHP	RPM	BHP	RPM	BHP	RPM	BHP	RPM	BHP	RPM	BHP	RPM	BHP	RPM	BHP	RPM	BHP	RPM	BHP
2000	439	0.31	480	0.40	522	0.48	565	0.56	607	0.63	647	0.70	685	0.76	719	0.82	753	0.90	785	0.99	816	1.09	846	1.18	874	1.27
2200	454	0.38	496	0.47	538	0.56	581	0.63	622	0.71	661	0.78	698	0.84	732	0.92	765	1.01	798	1.11	830	1.21	859	1.31	887	1.41
2400	470	0.45	512	0.55	555	0.64	598	0.72	638	0.79	676	0.87	711	0.94	745	1.02	779	1.13	813	1.24	845	1.35	875	1.46	902	1.55
2600	487	0.53	530	0.63	573	0.72	615	0.81	655	0.89	691	0.97	726	1.05	760	1.14	795	1.26	829	1.39	861	1.51	892	1.62	920	1.71
2800	506	0.62	549	0.73	592	0.82	634	0.91	672	0.99	707	1.08	741	1.17	776	1.28	811	1.42	846	1.55	879	1.67	909	1.79	938	1.89
3000	525	0.72	569	0.83	613	0.93	653	1.02	689	1.11	724	1.20	758	1.31	793	1.44	829	1.58	864	1.72	897	1.85	928	1.97	956	2.08
3200	547	0.84	591	0.95	634	1.05	672	1.14	707	1.23	741	1.34	776	1.47	812	1.61	848	1.76	883	1.91	916	2.04	946	2.16	975	2.28
3400	570	0.96	614	1.07	655	1.18	692	1.28	726	1.38	759	1.51	794	1.65	831	1.81	867	1.96	901	2.11	934	2.25	965	2.37	993	2.48
3600	594	1.09	638	1.21	676	1.32	711	1.43	744	1.55	778	1.69	814	1.85	850	2.01	886	2.18	920	2.33	953	2.47	983	2.59	1011	2.70
3800	620	1.24	661	1.36	698	1.48	731	1.60	763	1.73	797	1.89	833	2.06	869	2.24	904	2.40	939	2.55	971	2.69	1001	2.81	1029	2.92
4000	647	1.40	685	1.53	719	1.66	751	1.79	782	1.94	816	2.11	852	2.29	887	2.47	923	2.63	957	2.78	988	2.91	1018	3.03	1047	3.14
4200	672	1.58	707	1.72	740	1.85	771	2.00	801	2.16	834	2.34	870	2.53	905	2.71	940	2.87	974	3.02	1005	3.14	1035	3.26	1064	3.36
4400	696	1.78	729	1.93	760	2.07	790	2.22	820	2.39	852	2.59	887	2.78	922	2.95	957	3.11	990	3.25	1021	3.37	1051	3.48	1080	3.58
4600	719	2.00	751	2.14	781	2.29	810	2.45	839	2.63	869	2.83	903	3.03	938	3.20	972	3.36	1005	3.49	1037	3.60	1067	3.71	1097	3.81
4800	742	2.23	772	2.37	801	2.52	829	2.69	857	2.87	886	3.08	919	3.28	953	3.45	987	3.60	1020	3.72	1052	3.83	1083	3.93	1113	4.03

NOTE - MSAV® (Multi-Stage Air Volume) drive is capable of 350 - 1050 rpm.

BELT DRIVE | 20 TON

BLOWER DATA

SGH240HM BLOWER PERFORMANCE

NOTE - Blower Table Includes Resistance For Base Unit With Gas Heat, Wet Indoor Coil And Air Filters In Place.
See Blower Motor / Drive Kit Table on page 38 for Motor HP and Drive Kit RPM Ranges Available.

EXTERNAL STATIC PRESSURE - In. w.g.

Air Volume cfm	0.1		0.2		0.3		0.4		0.5		0.6		0.7		0.8		0.9		1.0		1.1		1.2		1.3		
	RPM	BHP	RPM	BHP	RPM	BHP	RPM	BHP	RPM	BHP	RPM	BHP	RPM	BHP	RPM	BHP	RPM	BHP	RPM	BHP	RPM	BHP	RPM	BHP	RPM	BHP	RPM
2000	255	0.33	310	0.48	366	0.63	416	0.74	458	0.81	498	0.89	537	0.99	573	1.10	607	1.22	642	1.35	677	1.49	712	1.65	749	1.80	
2200	258	0.37	313	0.52	369	0.67	418	0.78	460	0.85	500	0.92	538	1.03	574	1.15	609	1.27	643	1.40	678	1.55	714	1.70	751	1.86	
2400	261	0.40	316	0.56	372	0.70	421	0.81	462	0.88	502	0.96	540	1.07	576	1.19	610	1.32	645	1.45	680	1.60	716	1.76	753	1.92	
2600	265	0.44	319	0.60	375	0.74	423	0.85	464	0.92	505	1.00	542	1.11	578	1.24	612	1.37	646	1.51	682	1.66	718	1.82	755	1.98	
2800	268	0.48	322	0.63	378	0.77	426	0.89	467	0.95	507	1.04	545	1.16	580	1.29	614	1.42	648	1.56	684	1.72	720	1.88	757	2.04	
3000	272	0.51	326	0.67	382	0.81	429	0.92	470	0.99	510	1.09	547	1.21	582	1.34	616	1.48	650	1.63	686	1.78	723	1.94	759	2.10	
3200	276	0.55	330	0.71	386	0.85	433	0.96	473	1.03	513	1.13	550	1.26	584	1.40	618	1.54	652	1.69	688	1.85	725	2.01	762	2.16	
3400	280	0.59	335	0.74	391	0.88	437	1.00	477	1.08	516	1.18	552	1.32	587	1.46	620	1.61	655	1.76	691	1.91	727	2.07	764	2.23	
3600	285	0.62	340	0.78	395	0.92	441	1.04	480	1.12	520	1.24	555	1.38	589	1.53	623	1.67	657	1.83	693	1.98	730	2.14	767	2.30	
3800	290	0.66	345	0.81	400	0.96	445	1.08	484	1.17	523	1.29	559	1.44	592	1.59	626	1.74	660	1.90	696	2.06	733	2.22	770	2.38	
4000	296	0.69	351	0.85	406	0.99	449	1.12	488	1.22	527	1.35	562	1.51	595	1.66	629	1.82	663	1.97	699	2.14	736	2.30	773	2.46	
4200	301	0.73	358	0.88	411	1.03	453	1.17	493	1.27	531	1.41	565	1.57	599	1.73	632	1.89	666	2.05	702	2.22	739	2.39	776	2.56	
4400	308	0.76	364	0.92	416	1.07	458	1.22	497	1.33	534	1.48	569	1.64	602	1.81	635	1.97	670	2.14	706	2.31	743	2.48	779	2.66	
4600	315	0.80	371	0.95	422	1.12	463	1.26	502	1.39	539	1.54	573	1.71	606	1.88	639	2.05	673	2.22	710	2.40	746	2.58	783	2.76	
4800	322	0.83	378	0.99	427	1.16	468	1.32	507	1.45	543	1.62	577	1.79	609	1.96	642	2.14	677	2.32	714	2.50	751	2.69	788	2.87	
5000	330	0.86	386	1.03	433	1.21	473	1.38	512	1.52	547	1.69	581	1.87	613	2.05	647	2.22	682	2.41	718	2.60	755	2.79	792	2.98	
5200	338	0.89	393	1.07	438	1.27	478	1.44	517	1.59	551	1.77	585	1.95	617	2.13	651	2.32	686	2.50	722	2.70	759	2.89	796	3.08	
5400	346	0.92	400	1.12	444	1.33	484	1.51	522	1.67	556	1.86	589	2.04	622	2.23	655	2.41	690	2.60	727	2.79	764	2.98	801	3.17	
5600	355	0.96	407	1.17	450	1.40	490	1.58	528	1.76	561	1.96	594	2.14	626	2.33	660	2.51	695	2.70	732	2.89	769	3.08	806	3.27	
5800	364	1.00	414	1.23	457	1.47	496	1.65	533	1.85	566	2.06	599	2.24	631	2.43	665	2.61	701	2.81	737	3.00	774	3.19	811	3.38	
6000	372	1.04	422	1.29	463	1.54	502	1.73	539	1.95	571	2.17	604	2.35	636	2.53	670	2.72	706	2.91	743	3.11	779	3.30	816	3.50	
6200	381	1.08	429	1.36	470	1.62	508	1.82	544	2.05	576	2.28	609	2.46	641	2.64	676	2.82	712	3.02	749	3.22	785	3.42	822	3.62	
6400	390	1.14	437	1.44	477	1.71	515	1.92	550	2.16	582	2.39	614	2.57	647	2.74	682	2.93	718	3.14	755	3.34	792	3.54	828	3.75	
6600	399	1.20	444	1.53	484	1.80	521	2.02	556	2.28	587	2.51	620	2.68	653	2.85	688	3.04	725	3.25	762	3.46	798	3.67	835	3.87	
6800	408	1.27	452	1.62	491	1.89	528	2.13	562	2.40	593	2.63	625	2.80	659	2.96	694	3.15	731	3.37	768	3.58	805	3.80	842	4.01	
7000	417	1.35	460	1.71	498	1.99	535	2.24	568	2.52	599	2.74	631	2.91	665	3.08	700	3.27	737	3.48	775	3.70	812	3.92	848	4.14	
7200	426	1.45	467	1.82	505	2.10	541	2.36	574	2.65	606	2.86	638	3.02	671	3.19	707	3.39	744	3.60	781	3.83	818	4.05	855	4.27	
7400	435	1.55	475	1.93	513	2.22	548	2.49	580	2.77	612	2.98	644	3.14	677	3.31	713	3.50	750	3.72	788	3.94	825	4.17	861	4.39	
7600	444	1.67	483	2.05	520	2.34	555	2.62	587	2.90	618	3.10	650	3.26	684	3.43	719	3.62	756	3.84	794	4.06	831	4.29	868	4.51	
7800	452	1.80	491	2.18	528	2.47	562	2.75	594	3.02	625	3.22	657	3.38	690	3.55	726	3.74	763	3.96	800	4.18	837	4.40	874	4.62	
8000	461	1.93	500	2.31	536	2.61	570	2.89	601	3.15	632	3.35	664	3.51	697	3.67	732	3.87	769	4.08	806	4.30	843	4.52	880	4.74	
8200	470	2.08	508	2.45	544	2.75	577	3.03	608	3.29	639	3.47	671	3.63	704	3.80	739	3.99	775	4.20	812	4.42	849	4.64	886	4.86	
8400	479	2.23	516	2.60	552	2.90	585	3.18	615	3.42	646	3.60	678	3.76	711	3.93	746	4.11	782	4.32	819	4.54	855	4.76	892	4.98	
8600	488	2.39	525	2.76	560	3.05	592	3.33	623	3.56	653	3.74	685	3.89	718	4.06	752	4.24	788	4.44	825	4.66	862	4.88	898	5.10	
8800	498	2.56	533	2.91	568	3.21	600	3.48	630	3.70	661	3.87	692	4.02	725	4.19	759	4.37	795	4.57	831	4.78	868	5.00	904	5.21	
9000	507	2.73	542	3.08	576	3.37	608	3.63	638	3.85	668	4.01	699	4.16	732	4.32	766	4.50	802	4.69	838	4.90	874	5.12	911	5.33	
9200	516	2.91	551	3.25	584	3.53	616	3.78	645	3.99	676	4.15	707	4.29	739	4.45	773	4.63	808	4.82	844	5.03	881	5.24	917	5.46	
9400	526	3.09	560	3.42	593	3.69	623	3.94	653	4.13	683	4.28	714	4.43	746	4.58	780	4.76	815	4.95	851	5.15	887	5.36	923	5.58	
9600	535	3.27	569	3.59	601	3.86	631	4.10	661	4.28	691	4.42	721	4.56	753	4.72	787	4.89	822	5.08	858	5.28	894	5.49	930	5.70	

BLOWER DATA

MSAV® (MULTI-STAGE AIR VOLUME) BELT DRIVE KIT SPECIFICATIONS

Model No.	Nominal / Maximum - hp	Drive Kit Number	RPM Range
120	3	#3	660 - 900
		#4	865 - 1080
240	5	#4	520 - 685
	7.5	#5	685 - 865
		#7	770 - 965

FACTORY INSTALLED OPTIONS/FIELD INSTALLED ACCESSORY AIR RESISTANCE - in. w.g.

Air Volume cfm	Humiditrol Dehumidification Coil	Economizer	Filters MERV 13
036, 060 MODELS			
800	0.00	0.04	0.05
1000	0.00	0.04	0.07
1200	0.01	0.04	0.07
1400	0.02	0.04	0.07
1600	0.03	0.04	0.07
1800	0.04	0.05	0.07
2000	0.04	0.05	0.08
120 MODEL			
2000	0.03	0.06	0.03
2500	0.04	0.11	0.05
3000	0.05	0.13	0.06
3500	0.06	0.15	0.07
4000	0.08	0.19	0.08
4500	0.10	0.22	0.09
5000	0.12	0.29	0.10
5500	0.14	0.34	0.12
6000	0.15	0.52	0.13
240 MODEL			
3000	0.02	0.00	0.00
3500	0.04	0.00	0.00
4000	0.04	0.00	0.00
4500	0.04	0.00	0.00
5000	0.04	0.00	0.00
5500	0.06	0.01	0.01
6000	0.06	0.01	0.02
6500	0.08	0.01	0.02
7000	0.08	0.02	0.03
7500	0.10	0.02	0.04
8000	0.10	0.02	0.04
8500	0.10	0.03	0.04
9000	0.12	0.04	0.04
9500	0.14	0.04	0.06

POWER EXHAUST FANS STANDARD STATIC PERFORMANCE

120 Model		240 Model	
Return Air System Static Pressure	Air Volume Exhausted	Return Air System Static Pressure	Air Volume Exhausted
in. w.g.	cfm	in. w.g.	cfm
0.05	4085	0	10,200
0.10	3685	0.05	9700
0.15	3280	0.10	9200
0.20	2880	0.15	8600
0.25	2475	0.20	8100
---	---	0.25	7600
---	---	0.30	6900
---	---	0.35	6000
---	---	0.40	5000
---	---	0.45	4150

ELECTRICAL DATA
DIRECT DRIVE | 3 - 5 TON

Model No.		SGH036H4E			SGH060H4E		
¹ Voltage - 60hz		208/230V-3ph	460V-3ph	575V-3ph	208/230V-3ph	460V-3ph	575V-3ph
Compressor	Rated Load Amps	11.6	5.7	4	16.5	7.2	5.5
	Locked Rotor Amps	73	38	25.6	110	52	38.9
Outdoor Fan Motor(s)	Full Load Amps (total)	0.3 (0.6)	0.3 (0.6)	0.3 (0.6)	0.7 (1.4)	0.7 (1.4)	0.7 (1.4)
Service Outlet 115V GFI (Amps)		20	20	20	20	20	20
Indoor Blower Motor	Horsepower	1.5	1.5	1.5	1.5	1.5	1.5
	Type	Direct (ECM)	Direct (ECM)	Direct (ECM)	Direct (ECM)	Direct (ECM)	Direct (ECM)
	Full Load Amps	4.4	2.3	2.3	4.4	2.3	2.3
² Maximum Overcurrent Protection	Unit Only	30	15	15	40	15	15
³ Minimum Circuit Ampacity	Unit Only	20	11	8	27	13	11

NOTE - All units have a minimum Short Circuit Current Rating (SCCR) of 5000 amps.

¹ NOTE - Extremes of operating range are plus and minus 10% of line voltage.

² HACR type breaker or fuse.

³ Refer to National or Canadian Electrical Code manual to determine wire, fuse and disconnect size requirements.

ELECTRICAL DATA
BELT DRIVE | 10 TON

Model No.		SGH120H4		
¹ Voltage - 60hz		208/230V-3ph	460V-3ph	575V-3ph
Compressor 1	Rated Load Amps	16	7.8	5.7
	Locked Rotor Amps	110	52	38.9
Compressor 2	Rated Load Amps	16	7.8	5.7
	Locked Rotor Amps	110	52	38.9
Outdoor Fan Motors (3)	Full Load Amps (total)	3 (6)	1.5 (3)	1.2 (2.4)
Power Exhaust (1) 0.5 HP	Full Load Amps	3	1.5	1.2
Service Outlet 115V GFI (Amps)		20	20	20
Indoor Blower Motor	Horsepower	3	3	3
	Type	Belt	Belt	Belt
	Full Load Amps	10.6	4.8	3.9
² Maximum Overcurrent Protection	Unit Only	60	30	20
	With (1) 0.5 HP Power Exhaust	70	30	25
³ Minimum Circuit Ampacity	Unit Only	53	26	20
	With (1) 0.5 HP Power Exhaust	56	27	21

NOTE - All units have a minimum Short Circuit Current Rating (SCCR) of 5000 amps.

¹ NOTE - Extremes of operating range are plus and minus 10% of line voltage.

² HACR type breaker or fuse.

³ Refer to National or Canadian Electrical Code manual to determine wire, fuse and disconnect size requirements.

ELECTRICAL DATA
BELT DRIVE | 20 TON

Model No.		SGH240H4					
		208/230V-3ph		460V-3ph		575V-3ph	
¹ Voltage - 60hz							
Compressor 1	Rated Load Amps	16		7.8		5.7	
	Locked Rotor Amps	110		52		38.9	
Compressor 2	Rated Load Amps	16		7.8		5.7	
	Locked Rotor Amps	110		52		38.9	
Compressor 3	Rated Load Amps	16		7.8		5.7	
	Locked Rotor Amps	110		52		38.9	
Compressor 4	Rated Load Amps	16		7.8		5.7	
	Locked Rotor Amps	110		52		38.9	
Outdoor Fan Motors (6)	Full Load Amps	2.4		1.3		1	
	(total)	(14.4)		(7.8)		(6)	
Power Exhaust (3) 0.33 HP	Full Load Amps	2.4		1.3		1	
	(total)	(7.2)		(3.9)		(3)	
Service Outlet 115V GFI (Amps)		20		20		20	
Indoor Blower Motor	Horsepower	5	7.5	5	7.5	5	7.5
	Full Load Amps	16.7	24.2	7.6	11	6.1	9
² Maximum Overcurrent Protection	Unit Only	110	125	50	60	40	45
	With (3) 0.33 HP Power Exhaust	110	125	60	60	45	50
³ Minimum Circuit Ampacity	Unit Only	100	107	49	52	37	40
	With (3) 0.33 HP Power Exhaust	107	116	53	57	40	44

NOTE - All units have a minimum Short Circuit Current Rating (SCCR) of 5000 amps.

¹ NOTE - Extremes of operating range are plus and minus 10% of line voltage.

² HACR type breaker or fuse.

³ Refer to National or Canadian Electrical Code manual to determine wire, fuse and disconnect size requirements.

OUTDOOR SOUND DATA

Unit Model No.	Octave Band Sound Power Levels dBA, re 10 ⁻¹² Watts Center Frequency - HZ							¹ Sound Rating Number dBA
	125	250	500	1000	2000	4000	8000	
036	55	59	63	61	57	48	39	67
060	65	71	74	72	69	63	54	78
120	80	79	79	76	71	65	57	89
240	94	91	90	87	83	79	72	92

Note - The octave sound power data does not include tonal corrections.

¹ Sound Rating Number according to AHRI Standard 270-95 or AHRI Standard 370-2001 (includes pure tone penalty). Sound Rating Number is the overall A-Weighted Sound Power Level, (LWA), dB (100 Hz to 10,000 Hz).

UNIT CLEARANCES

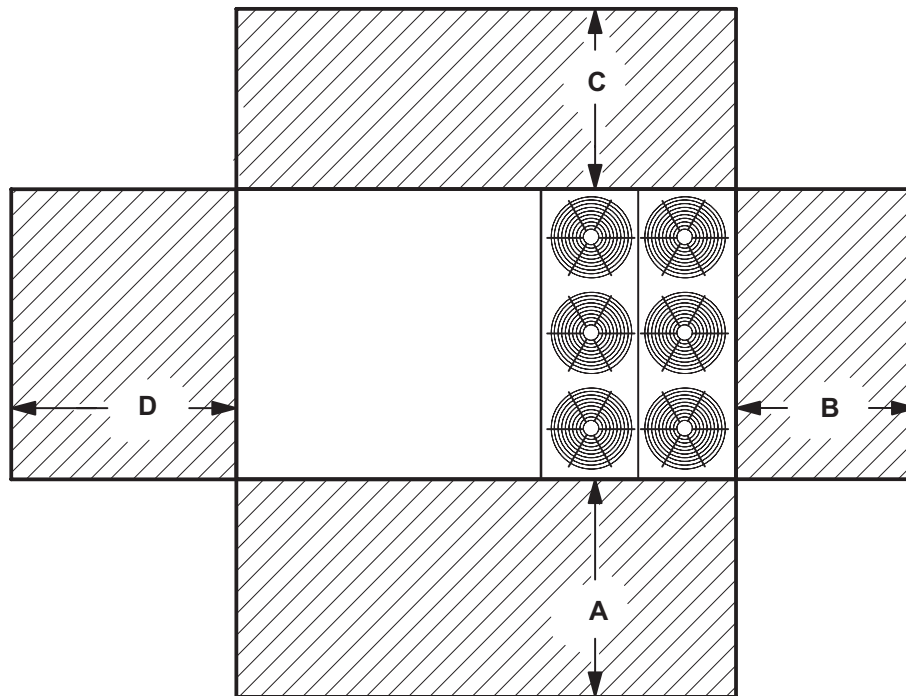

¹ Unit Clearance	A		B		C		D		Top Clearance	
	in.	mm	in.	mm	in.	mm	in.	mm		
Service Clearance	036, 060	48	1219	36	914	60	1524	60	1524	Unobstructed
	120	60	1524	36	914	60	1524	60	1524	Unobstructed
	240	72	1829	36	914	60	1524	96	2438	Unobstructed
Clearance to Combustibles	All	36	914	1	25	1	25	1	25	Unobstructed
Minimum Operation Clearance	All	36	914	36	914	36	914	36	914	Unobstructed

NOTE - Entire perimeter of unit base requires support when elevated above the mounting surface.

¹ Service Clearance - Required for removal of serviceable parts.

Clearance to Combustibles - Required clearance to combustible material.

Minimum Operation Clearance - Required clearance for proper unit operation.

WEIGHT DATA

Model Number	Net		Shipping	
	lbs.	kg	lbs.	kg
SGH036 Base Unit	857	389	967	439
SGH036 Max Unit	966	438	1066	484
SGH060 Base Unit	880	399	980	445
SGH060 Max Unit	1000	454	1100	499
SGH120 Base Unit	1545	701	1645	746
SGH120 Max Unit	1757	797	1857	842
SGH240 Base Unit	2753	1249	2853	1294
SGH240 Max Unit	3204	1453	3304	1499

NOTE - Base Unit is with Standard Gas Heat, NO OPTIONS.

NOTE - Max. Unit is the unit with ALL INTERNAL OPTIONS Installed. (High Gas Heat, Economizer, Standard Static Power Exhaust Fans, Humiditrol, Controls, etc.). Does not include accessories EXTERNAL to unit.

OPTIONS / ACCESSORIES

Description		Weight	
		lbs.	kg
CABINET			
Combination Coil/Hail Guards	036 or 060	24	11
	120	25	11
	240	50	23
ECONOMIZER / OUTDOOR AIR / EXHAUST			
Economizer	036 or 060	50	23
	120	70	32
	240	138	63
Outdoor Air Dampers	240	68	31
Power Exhaust	120	28	13
	240	99	45
Heat Exchanger	036-060 Standard Heat	24	11
	036-060 Medium Heat	32	15
	060 High Heat	43	20
	120 Standard Heat	75	34
	120 Medium Heat	84	38
	120 High Heat	107	49
	240 (x 2) Standard Heat	150	68
	240 (x 2) Medium Heat	168	76
240 (x 2) High Heat	214	97	
PACKAGING			
LTL Packaging (less than truck load)	036 or 060	90	41
	120	105	48
	240	300	136
ROOF CURBS			
Hybrid Roof Curbs, Downflow 14 in. height	036 or 060	70	32
	120	80	36
	240	115	52
Hybrid Roof Curbs, Downflow 24 in. height	036 or 060	105	48
	120	120	54
	240	170	77
HUMIDITROL® DEHUMIDIFICATION SYSTEM			
Humiditrol Dehumidification Option (Net Weight)	036 or 060	27	12
	120	57	26
	240	100	45

DIMENSIONS - UNIT

SGH036H | SGH060H

CORNER WEIGHTS								CENTER OF GRAVITY				
Model No.	AA		BB		CC		DD		EE		FF	
	lbs.	kg	lbs.	kg	lbs.	kg	lbs.	kg	in.	mm	in.	mm
SGH036H Base Unit	155	70	216	98	284	129	203	92	35-3/4	908	30-7/8	784
SGH036H Max. Unit	166	75	251	114	330	150	219	99	35-3/4	908	31-7/8	810
SGH060H Base Unit	154	70	215	98	297	135	213	97	34-3/4	883	30-7/8	784
SGH060H Max. Unit	167	76	253	115	349	158	231	105	34-3/4	883	31-7/8	810

Max. Unit - The Base Unit with ALL OPTIONS Installed. (Economizer and controls)

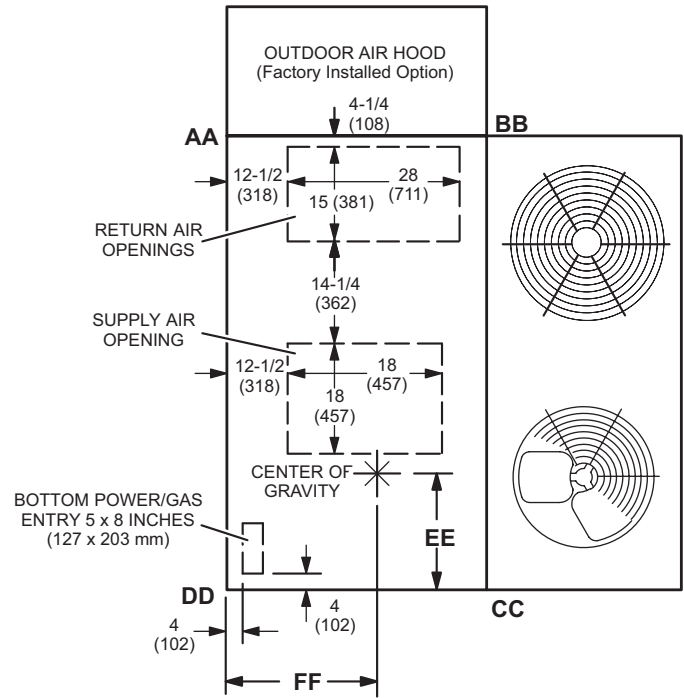

TOP VIEW

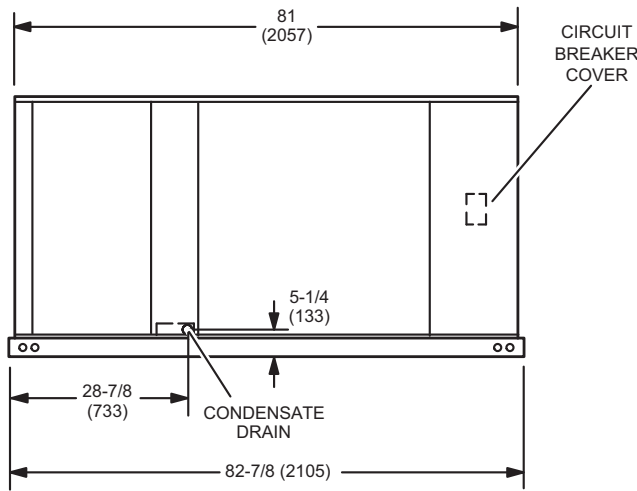

SIDE VIEW

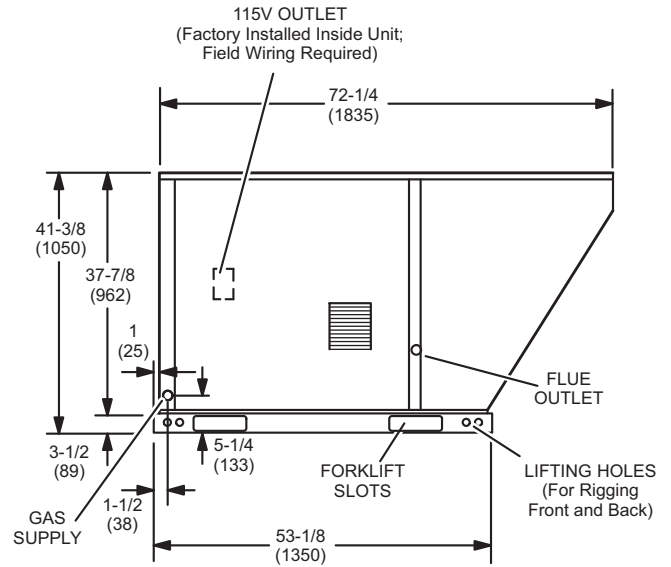

FRONT VIEW

DIMENSIONS - UNIT

SGH120H

CORNER WEIGHTS									CENTER OF GRAVITY			
Model No.	AA		BB		CC		DD		EE		FF	
	lbs.	kg	lbs.	kg	lbs.	kg	lbs.	kg	in.	mm	in.	mm
SGH120H Base Unit	416	189	311	141	350	159	468	212	42-1/2	1080	37	940
SGH120H Max. Unit	473	215	354	161	398	181	532	241	42-1/2	1080	37	940

Max. Unit - The Base Unit with ALL OPTIONS Installed. (Economizer and controls)

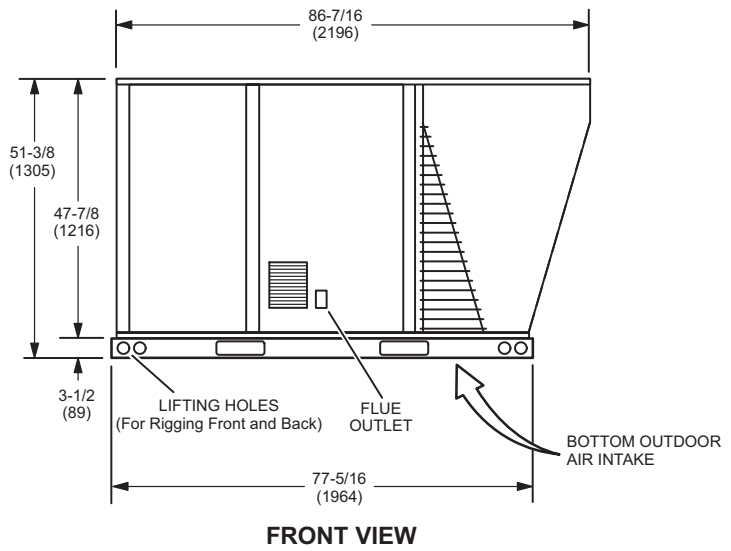
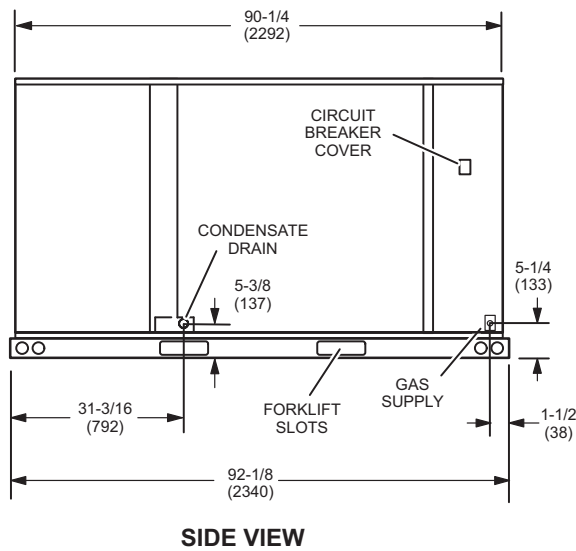
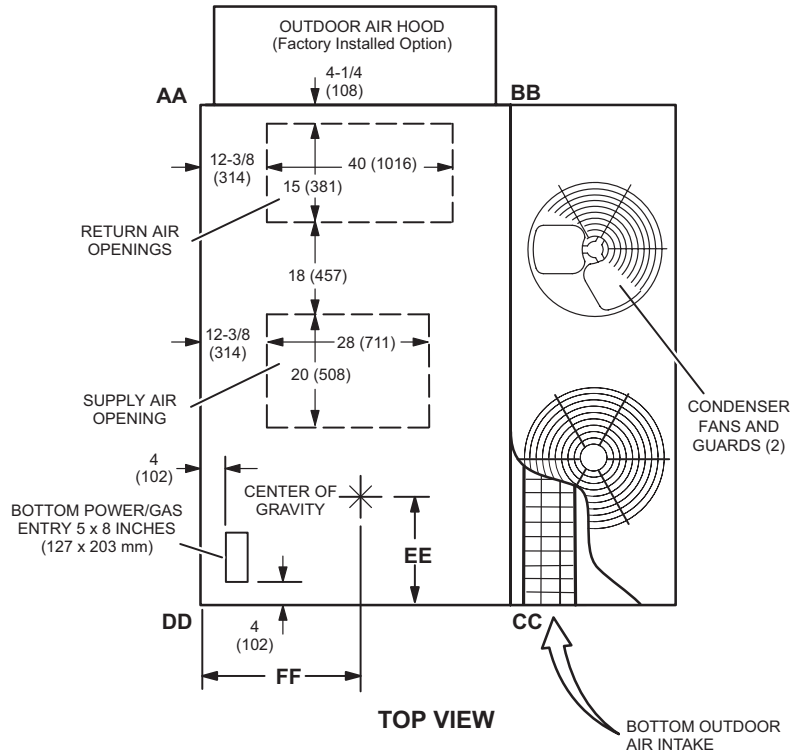

DIMENSIONS - UNIT

SGH240H

CORNER WEIGHTS									CENTER OF GRAVITY			
Model No.	AA		BB		CC		DD		EE		FF	
	lbs.	kg	lbs.	kg	lbs.	kg	lbs.	kg	in.	mm	in.	mm
SGH240H Base Unit	564	256	583	264	816	370	790	358	38-1/8	968	61-1/4	1556
SGH240H Max. Unit	656	298	679	308	950	431	919	417	38-1/8	968	61-1/4	1556

Max. Unit - The Base Unit with ALL OPTIONS Installed. (Economizer and controls)

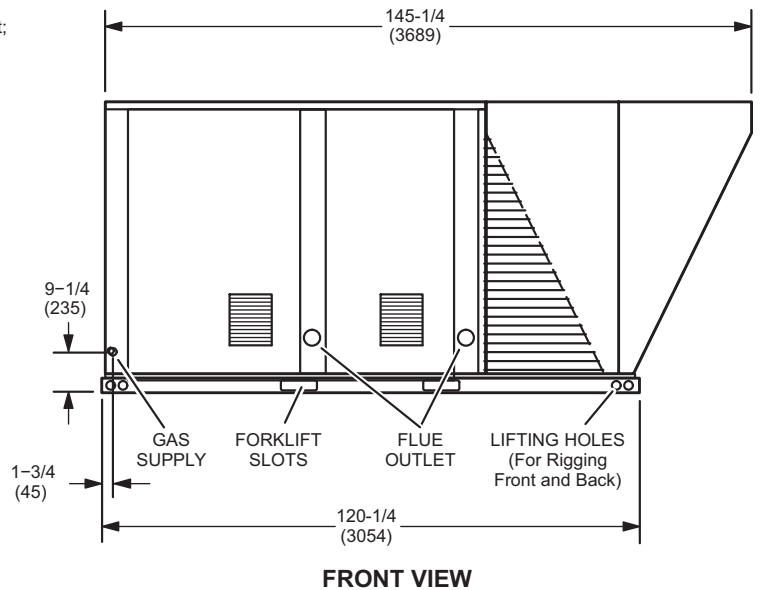
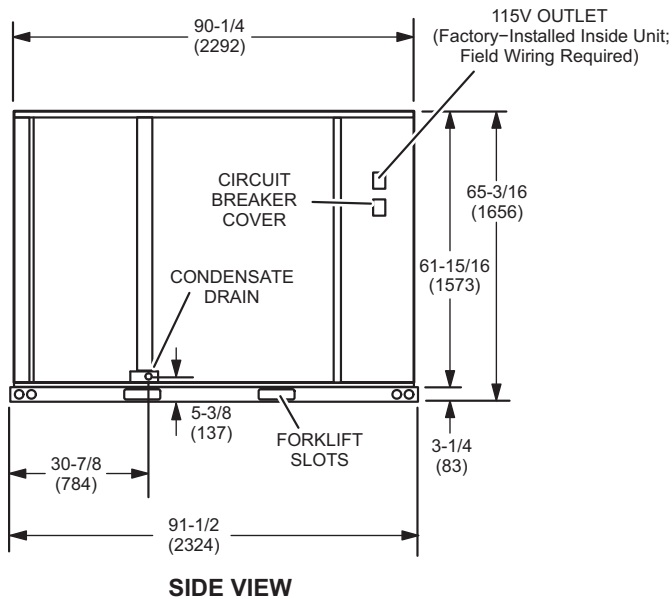
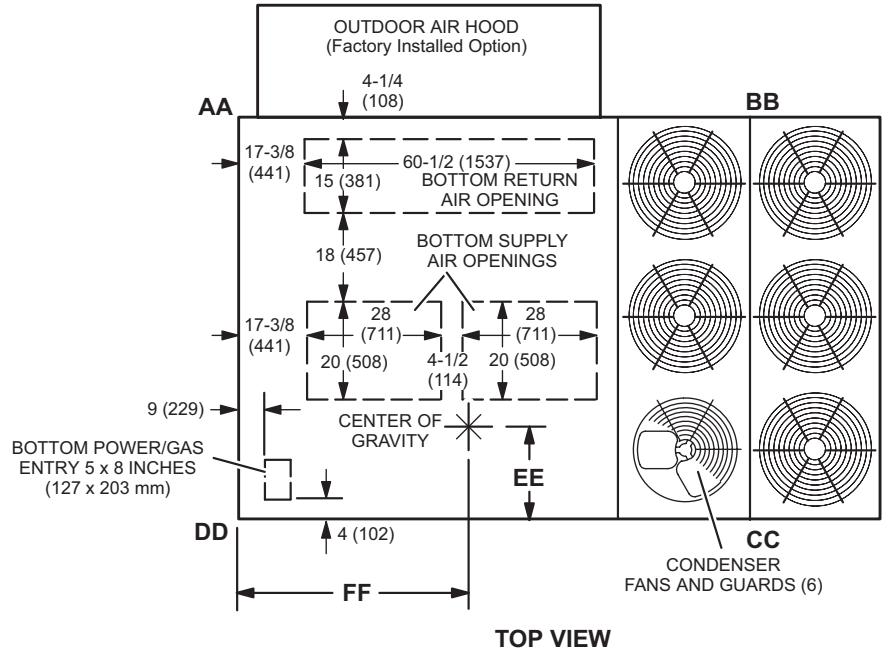

**OPTIONAL OUTDOOR AIR HOOD DETAIL
036 or 060 Models**

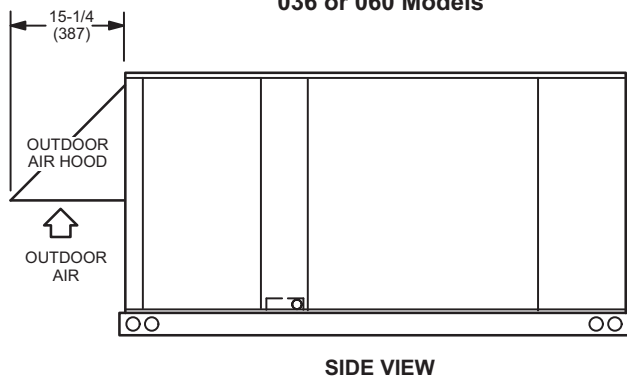

**OPTIONAL OUTDOOR AIR HOOD DETAIL
OPTIONAL POWER EXHAUST DETAIL
120H Models**

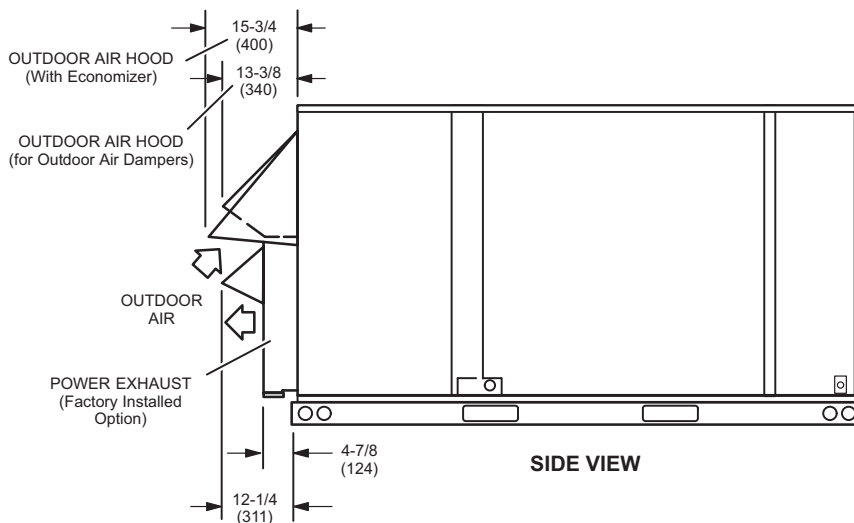

**OPTIONAL OUTDOOR AIR HOOD DETAIL
240H Models**

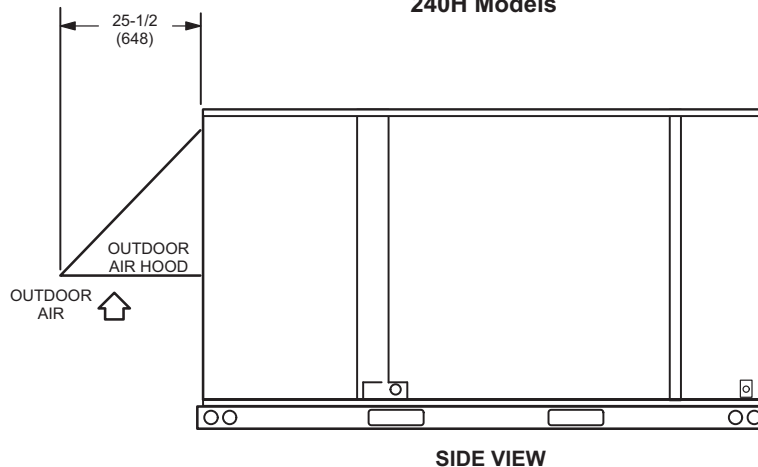

DIMENSIONS - ACCESSORIES

HYBRID ROOF CURBS - 036-060 MODELS - DOUBLE DUCT OPENING

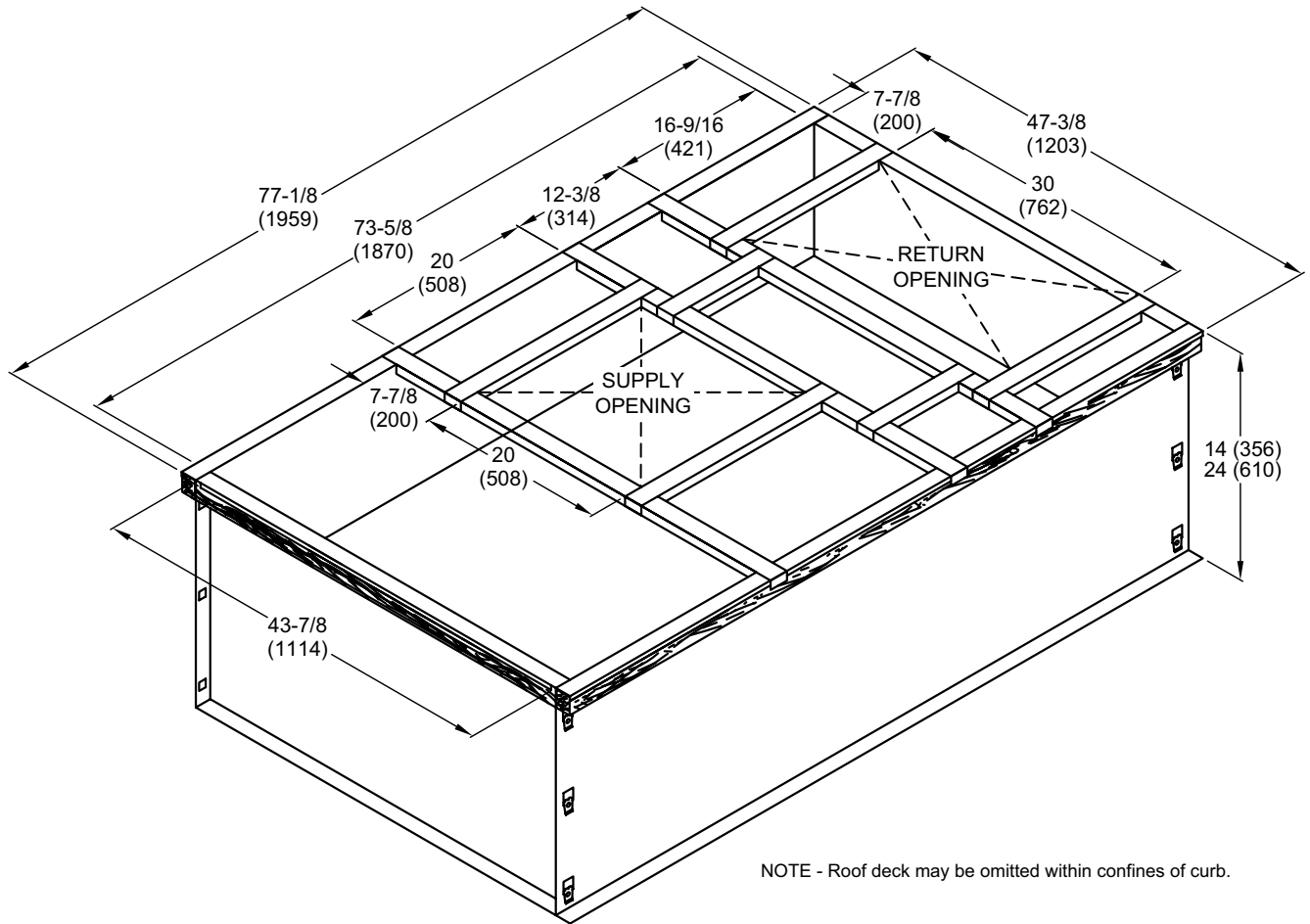

NOTE - Roof deck may be omitted within confines of curb.

TYPICAL FLASHING DETAIL FOR ROOF CURB

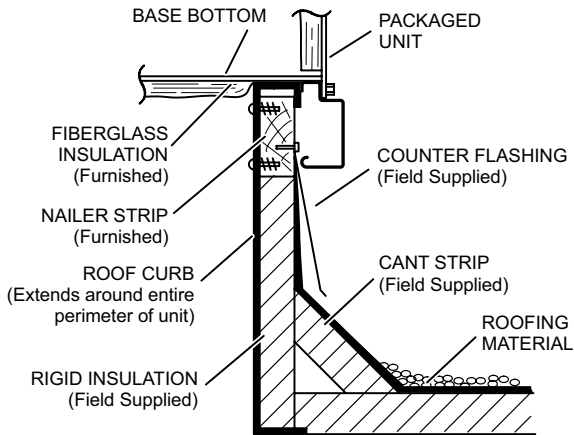

DETAIL ROOF CURB

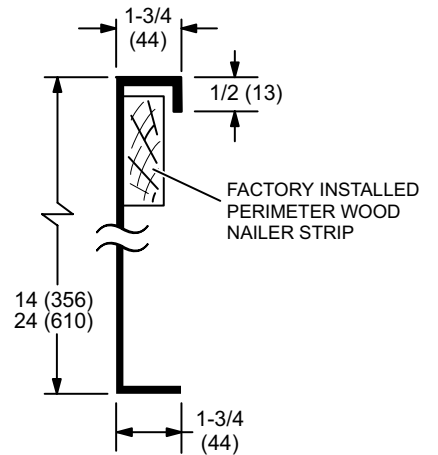

DIMENSIONS - ACCESSORIES

HYBRID ROOF CURBS - 120 MODEL - DOUBLE DUCT OPENING

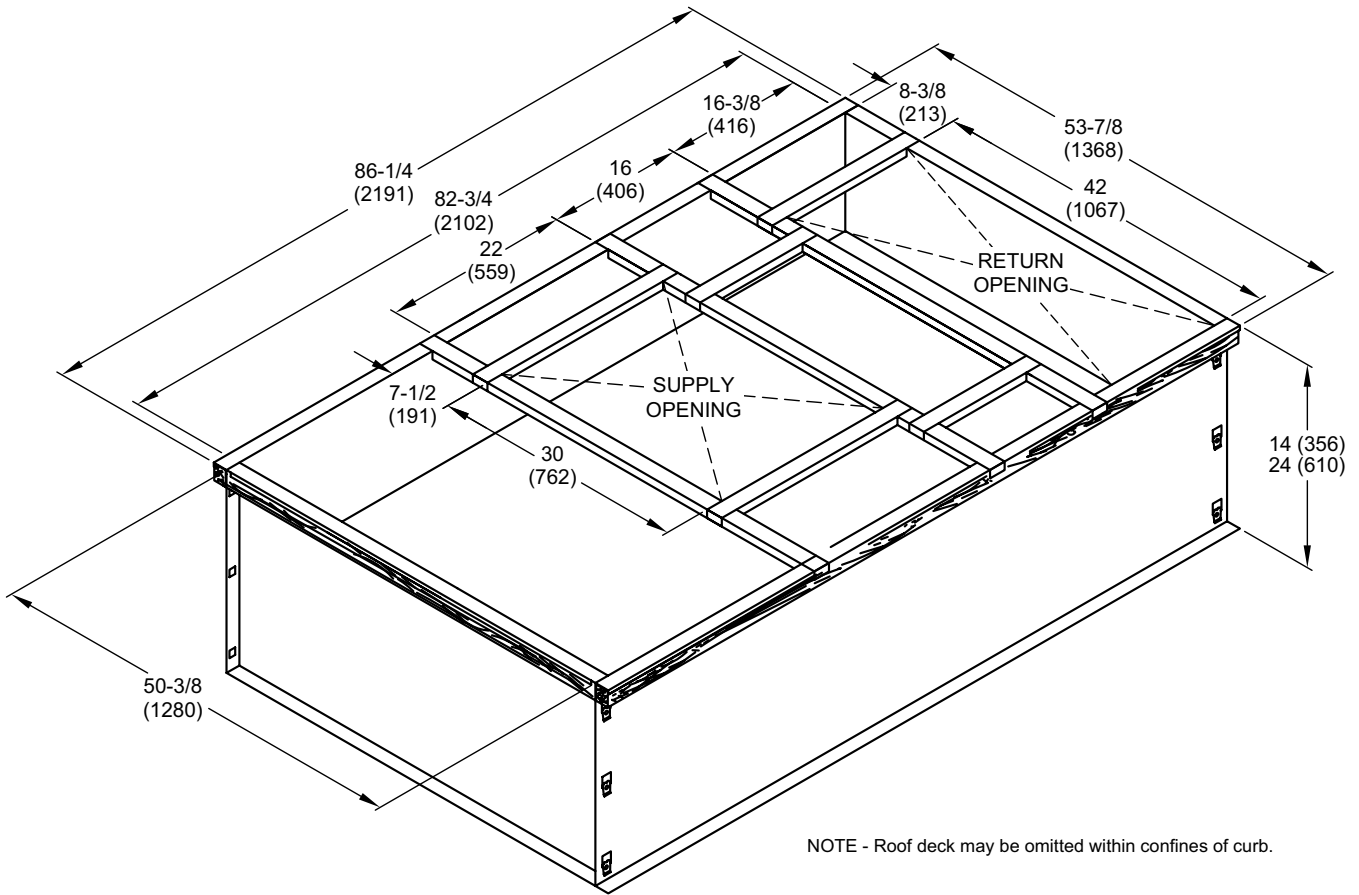

TYPICAL FLASHING DETAIL FOR ROOF CURB

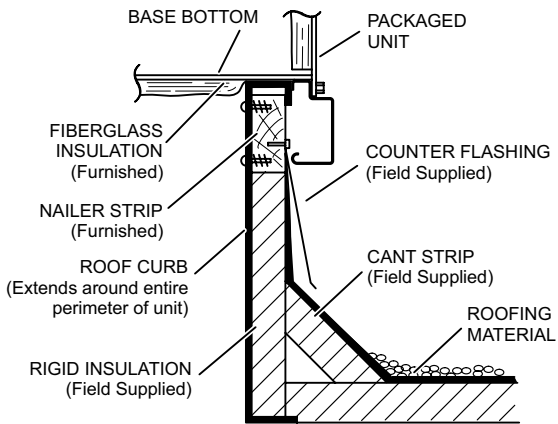

DETAIL ROOF CURB

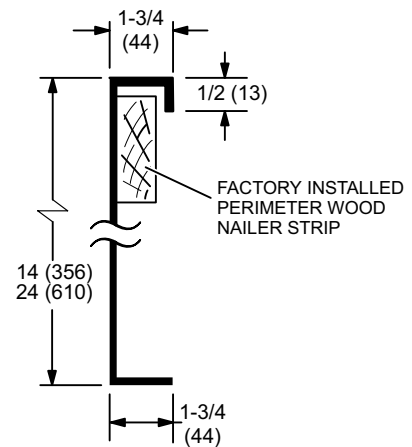

DIMENSIONS - ACCESSORIES

HYBRID ROOF CURBS - 240 MODEL - FULL PERIMETER - DOUBLE DUCT OPENING

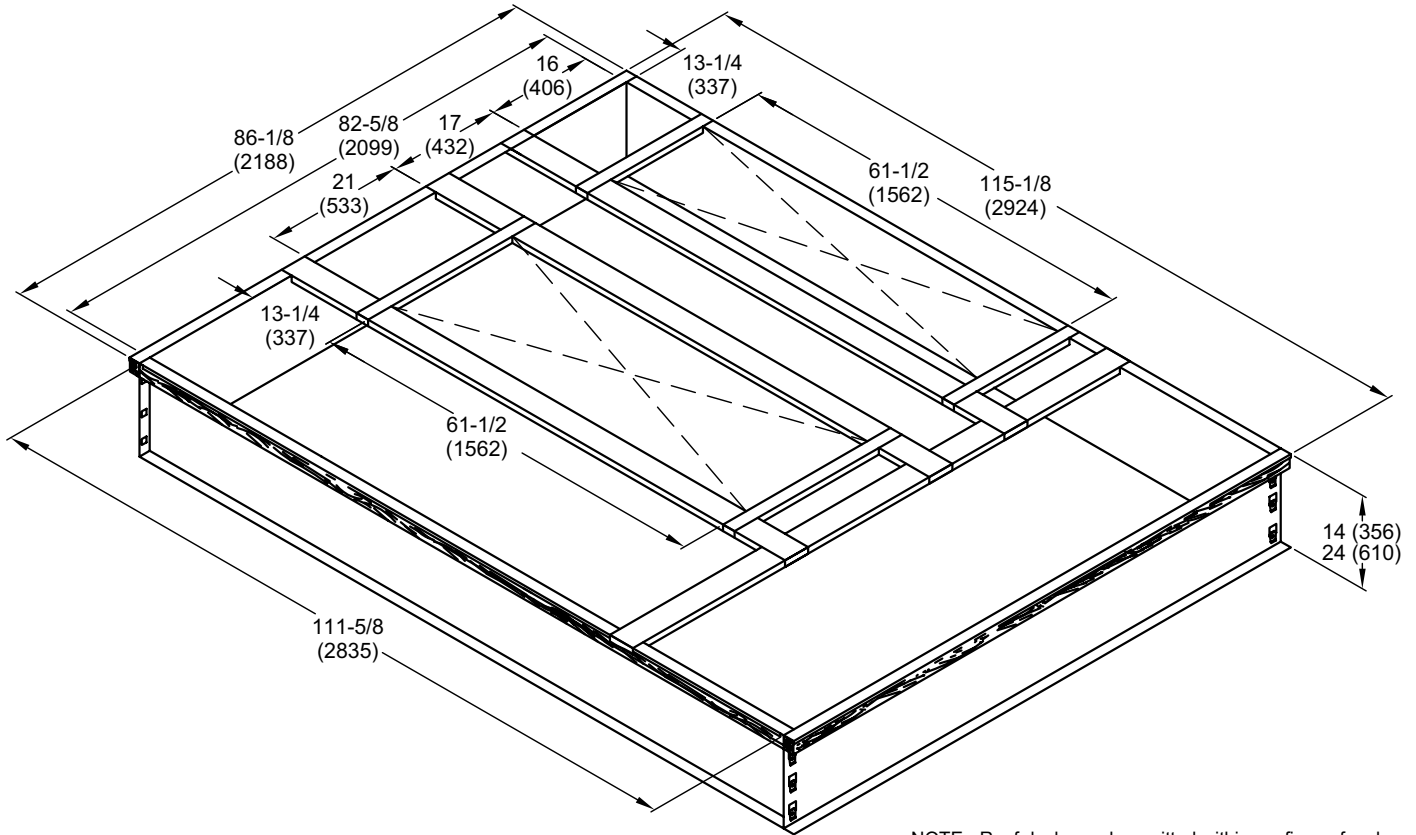

NOTE - Roof deck may be omitted within confines of curb.

TYPICAL FLASHING DETAIL FOR ROOF CURB

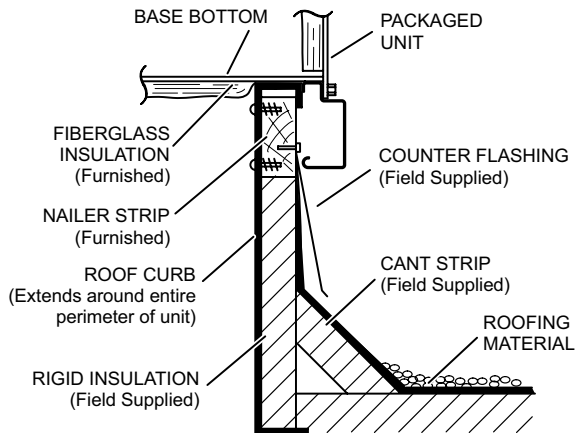

DETAIL ROOF CURB

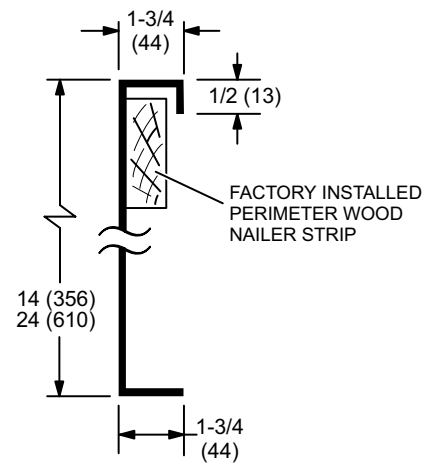

REVISIONS

Sections	Description of Change
Options / Accessories	Updated Combustion Air Intake Extension usage - new model for 036 sizes. GFI Service Outlets 15 amp, factory-wired and powered - Added field option for 240 models.



Visit us at www.lennox.com

For the latest technical information, www.lennoxcommercial.com

Contact us at 1-800-4-LENNOX

NOTE - Due to Lennox' ongoing commitment to quality, Specifications, Ratings and Dimensions subject to change without notice and without incurring liability. Improper installation, adjustment, alteration, service or maintenance can cause property damage or personal injury. Installation and service must be performed by a qualified installer and servicing agency.

©2020 Lennox Industries, Inc.