



SL280UHV
DAVE LENNOX SIGNATURE® COLLECTION
 Upflow / Horizontal - Two-Stage Heat - Variable Speed Blower - 60Hz

**RESIDENTIAL
 PRODUCT SPECIFICATIONS**

Bulletin No. 210600
 June 2020
 Supersedes July 2019



So simple. So smart. So comfortable.



AFUE - 80%
Input - 66,000 to 132,000 Btuh
Nominal Add-on Cooling - 2 to 5 Tons

MODEL NUMBER IDENTIFICATION

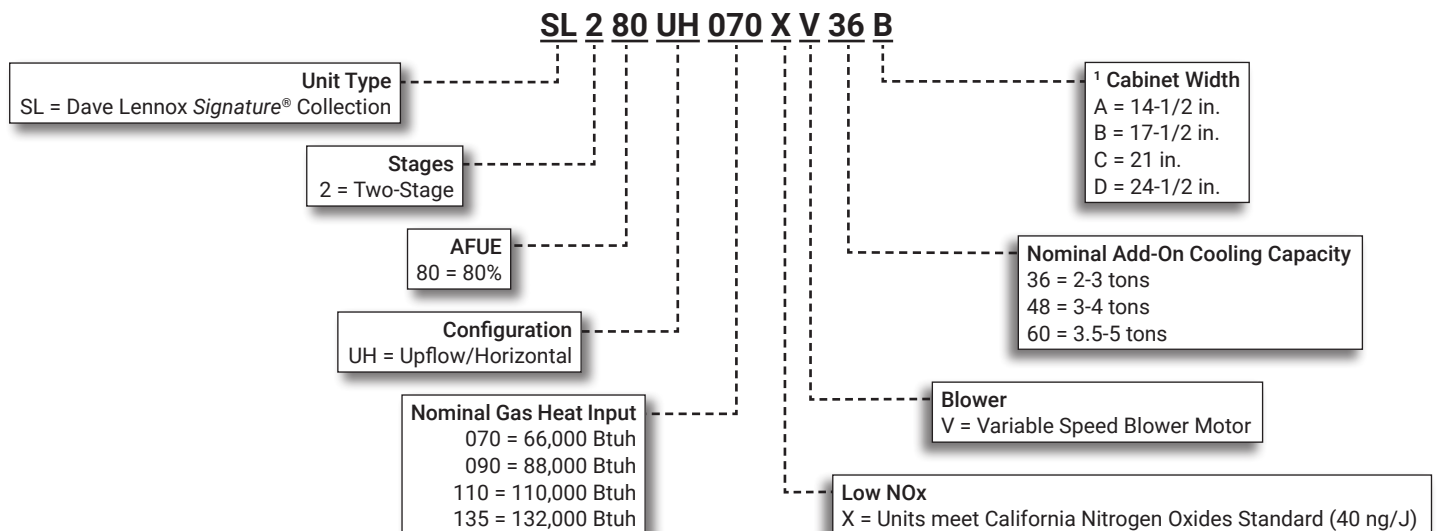

¹ Indoor coils with the same letter designation physically matches the furnace.

FEATURE HIGHLIGHTS

1. SilentComfort™ Technology
2. Lennox Duralok™ Heat Exchanger Assembly
3. Inshot Burners
4. SureLight® Hot Surface Ignitor
5. Two-Stage Gas Control Valve
6. Two-Speed Combustion Air Inducer
7. Flame Roll-Out Switch
8. Variable Speed Direct Drive Blower
9. SureLight® Integrated Furnace Control
10. Insulated Cabinet
11. Safety Interlock Switch
12. Gas Piping and Electrical Inlets

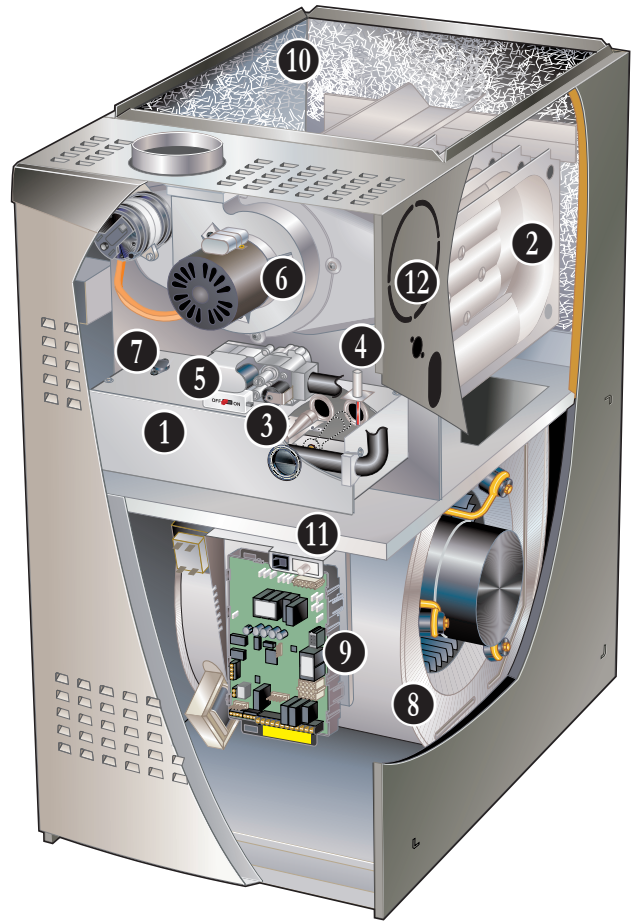

NOTE - SL280V FURNACES ARE NOT AVAILABLE IN CANADA!
NOTE - SL280V FURNACES CANNOT BE TWINNED!

CONTENTS

Approvals and Warranty	3
Blower Data	15
Dimensions - Furnace/Coil Combined Dimensions	14
Dimensions - Horizontal Position	12
Dimensions - Optional Accessories	13
Dimensions - Upflow Position	11
Gas Heat Accessories	10
High Altitude Derate	10
Installation Clearances	8
Model Number Identification	1
Optional Accessories - Order Separately	10
Specifications	9

APPROVALS AND WARRANTY

APPROVALS

- AHRI Certified
- Tested and rated according to US DOE test procedures and FTC labeling regulations
- "X" models approved by the California Energy Commission and meets California Nitrogen Oxides Standard (NOx) limits of 40 ng/J
- ISO 9001 Registered Manufacturing Quality System
- Blower data from unit tests conducted in Lennox Laboratory air test chamber

California Only

- These furnaces **do not meet** the South Coast Air Quality Management District (SCAQMD) Rule 1111 and San Joaquin Valley Air Pollution Control District (SJVAPCD) Rule 4905 NOx emission limit (14 ng/J) and cannot be installed within the SCAQMD and SJVAPCD areas
- All "X" model furnaces are approved by the California Energy Commission and meets California Nitrogen Oxides Standard (NOx) limits of 40 ng/J

WARRANTY

- Heat Exchanger:
 - Limited twenty years in residential applications
 - Limited ten years in non-residential applications
- All other covered components:
 - Limited five years in residential installations
 - Limited one year in non-residential installations

FEATURES

APPLICATIONS

- Input capacities of 66,000, 88,000, 110,000 and 132,000 Btuh
- Energy efficiency (AFUE) - 80%
- Compact cabinet
- Lennox add-on indoor coils, high-efficiency air cleaners and humidifiers can easily be added to furnace
- Shipped factory assembled with all controls installed and wired
- Ready for installation in upflow or horizontal right-hand position without any modifications

NOTE - Horizontal left-hand position requires repositioning of pressure switch.

- Removable bottom seal panel shipped in place for side return air is easily removed for bottom/end return air applications
- Each unit factory test operated to ensure proper operation

ZONING APPLICATIONS

- Can be used with the Lennox iHarmony® Zoning System with the iComfort® Communicating Thermostat
- iHarmony® Zoning System provides direct feedback to the furnace, controlling both airflow and heat output to match the comfort requirements for up to four zones

HEATING SYSTEM

- 1 **SilentComfort™ Technology**
 - Patent pending burner sound enclosure and extra cabinet insulation reduces operating sound levels
- 2 **Lennox Duralok™ Heat Exchanger Assembly**
 - Heavy gauge aluminized steel heat exchanger
 - Crimped seam clamshell design
 - Designed for normal expansion and contraction
 - Minimum resistance to air flow
 - Laboratory life cycle tested in excess of industry standards
 - Compact size permits low overall design of furnace cabinet
- 3 **Inshot Burners**
 - Aluminized steel inshot burners provide efficient, trouble-free operation
 - Burner venturi mixes air and gas in correct proportion for proper combustion
 - Burner assembly is removable from the unit as a single component for ease of service

FEATURES

HEATING SYSTEM (continued)

- 4 **SureLight® Hot Surface Ignitor**
 - Tough, reliable, long-life, trouble-free performance
 - Silicon nitride ignitor
 - Cemented to steatite block for protection against current leakage
 - Ignition leads are constructed of nickel plated copper and are enclosed in high temperature Teflon® insulation for dependable operation
- 5 **Two-Stage Gas Control Valve**
 - 24 volt redundant combination two-stage gas control valve combines manual shut off switch (On-Off), automatic electric valve (dual) and gas pressure regulation into a compact combination control
- 6 **Two-Speed Combustion Air Inducer**
 - Heavy duty, permanent split capacitor (PSC) two-speed blower prepurges heat exchanger and safely vents flue products
 - Dual pressure switches (low fire/high fire) prove blower operation before allowing gas valve to open
 - Operates only during heating cycle
 - Direct access allows inducer assembly to be rotated 90° clockwise or counterclockwise to facilitate easy vent attachment
- 7 **Flame Rollout Switches (2)**
 - Factory installed on burner box
 - Switches provide protection from abnormal operating conditions
 - Manual reset

Limit Controls

- Primary limit located on vestibule panel
- Secondary limit located on blower housing
- Automatic reset

Optional Accessories

High Altitude Pressure Switch Kit

- Required on most units for proper unit operation at altitudes from 4501 to 10,000 ft.

Natural Gas to LPG/Propane Conversion Kit

- Required for field changeover from natural gas to LPG/Propane

LPG/Propane to Natural Gas Conversion Kit

- Required for field changeover from LPG/Propane to natural gas

Vent Adaptor (Upflow Applications Only)

- Allows venting through a masonry chimney without the need of a flue liner
- Manual reset temperature sensor protects against abnormal operating conditions
- Sensor wiring may be routed from either side of adaptor

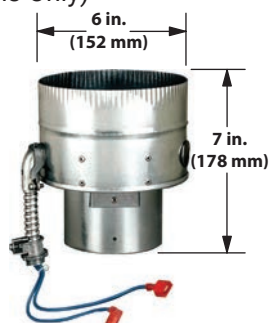

- Minimum winter design temperatures:
 - -10°F when used with interior masonry chimneys
 - +5°F when used with exterior masonry chimneys

NOTE - Refer to Winter Design Temperatures Map on page 8 for application information. Also refer to the installation instructions for detailed information.

BLOWER

- 8 **Variable Speed Direct Drive Blower**
 - Each blower assembly statically and dynamically balanced
 - Blower assembly easily removed for servicing

Variable Speed Blower Motor

- Variable speed motor maintains specified air volume from 0 though 0.80 in. w.g. (heating) and 0 through 1.0 in. w.g. (Cooling) static range
- Variable speed operation is achieved by the use of an ECM (Electronically Commutated Motor) motor
- Motor is controlled by furnace control
- Change in blower speed is easily accomplished by simple DIP switch change on the furnace control
- Motor is resiliently mounted
- See Blower Data tables

NOTE - When furnaces are used with the iHarmony® Zoning System and the iComfort® Communicating Thermostat, the blower motor operates from predetermined minimum - maximum air volumes to satisfy zone requirements.

CONTROLS

- 9 **SureLight® Integrated Furnace Control (iComfort® Communicating)**

- Advanced control communicates information about various operating parameters in the furnace to the optional iComfort® Communicating Thermostat to constantly maintain the highest level of comfort and performance available

- **Auto Configuration** - On start-up the control automatically sends a description of the unit to the optional iComfort® Communicating Thermostat to automatically configure the number of stages and features available
- Terminals for connecting a conventional heating/cooling thermostat are also provided on the control
- Control also features Innovative AirFlex™ technology allows custom blower settings based on the application
- **Thermostat Control** - For optimal performance, the use of a high-quality, digital two-stage thermostat with adjustable settings for first stage/second stage, on/off differentials and adjustable stage timers are recommended



FEATURES

CONTROLS (continued)

Furnace Input Staging Options

Thermostat Type	Input Staging Available
iComfort® S30 Communicating Thermostat	Two-Stage (65 and 100%)
Two-Stage (Conventional)	
Single-Stage (Conventional)	

- **Safety Controls** - Flame sensor utilizes flame rectification for safe and reliable operation
- Should flame fail to ignite, control will initiate 4 re-attempts at ignition before locking out unit operation for 60 minutes
- Watchguard type circuit automatically resets ignition controls after one hour of continuous thermostat demand after unit lockout, eliminating calls for service
- **Display LED** - Seven segment LED displays alpha-numeric information related to diagnostics as well as system operation and status
- Diagnostic codes are held in non-volatile memory, immune from power interruptions
- Stores up to ten diagnostic codes in order of occurrence for recall on demand
- Port on blower door allows for easy viewing

DIP Switch Settings

- **Select Thermostat Used** - Single-Stage or Two-Stage
- Two selectable second stage recognition times (7 and 12 minutes) are available on the control when the furnace is used with a single-stage thermostat
- When used with a two-stage thermostat, furnace will only initiate second stage operation with a second stage thermostat demand
- **Heating Speeds** - A combination of DIP switch settings allow the following motor speed selection settings within the heating speed selected for fine tuning air volume:
 - Factory default
 - 6%, 12%, 18% or 24% increase
 - 6%, 12% or 18% decrease
 - See Blower Performance tables
- **Cooling Speeds** - A combination of DIP switch settings allow the following motor speed selection settings within the cooling speed selected for fine tuning air volume:
 - Factory default
 - 10% increase
 - 10% decrease
 - See Blower Performance tables
- **Blower Speed Ramping (Cooling Mode)** - DIP switch settings allow one of four blower speed profiles during cooling operation

- **Profile A (factory setting)** - Motor runs at 50% for 30 seconds, then at 82% for 7-1/2 minutes, then at 100% (if needed) until demand is satisfied. Once demand is met, motor runs at 50% for 30 seconds, then ramps down to stop
- **Profile B** - Motor runs at 82% for 7-1/2 minutes and then at 100% (if needed) until demand is satisfied. Once demand is met, motor ramps down to stop
- **Profile C** - Motor runs at 100% until demand is satisfied. Once demand is met, motor runs at 100% for 60 seconds, then ramps down to stop
- **Profile D** - Motor runs at 100% until demand is satisfied. Once demand is met, motor ramps down to stop
- **Dehumidification (Active or Humiditrol® Option)** - A jumper on the control must be clipped to enable active dehumidification and/or operation with a Humiditrol® Whole-Home Dehumidification System
- A humidity controlling thermostat or device is also required
- During a call for cooling, air volume is automatically reduced, forcing humidity removal by the air conditioner or heat pump system
- After the humidity has reached the desired set-point the cooling air volume returns to its designed rate. A dehumidification signal from the thermostat reduces the cooling cfm to 70% of the requested cooling cfm
- **Dual-Fuel Operation** - A jumper on the control must be clipped to enable operation with a single or two-stage heat pump. The indoor blower is started without delay when a call for heat is received
- **Two-Stage Compressor Operation** - A jumper on the control must be clipped to enable operation with a two-stage compressor
- **Lennox System Operations Monitor Connection** - Monitors outdoor unit operation (communicating mode)
- **Blower On/Off Time (Heating)** - Blower on time is fixed at 30 seconds, blower off time is adjustable from 60, 90, 120 and 180 seconds (factory setting - 90 seconds)
- **Blower On/Off Time (Cooling)** - For air-conditioning applications, blower on time is 2 seconds following thermostat demand for cooling
- See Blower Speed Ramping (Cooling Mode) profiles for various blower off details
- Controls evaporator humidity by controlling blower and compressor speed on two-stage outdoor units when used with the iComfort® Communicating Thermostat
- **Continuous Blower Speed** - Adjustable continuous blower speed is a percentage of the high cooling speed selection
- Four selectable options (via DIP switch settings) of 28%, 38% (default setting), 70% and 100%
- **Accessory Terminal** - One accessory terminal furnished for additional power supply requirements for 120 volt (less than 1 amp) powered air cleaners
- One unpowered pair of contacts are provided for humidifier connections and may be connected to 24V or 120V
- Control is factory installed in the unit control box

FEATURES

CONTROLS (continued)

24 Volt Transformer

- Furnished and factory installed in control box
- 40VA transformer has circuit breaker wired in series

Field Wiring Make-Up Box

- Furnished for line voltage wiring
- Factory installed internally on left side of furnace
- Box may be installed internally or externally on either side of furnace

Optional Accessories

iComfort® S30 Ultra-Smart Wi-Fi Thermostat (part of the iComfort® Residential Communicating Control System)

- Recognizes and connects to all iComfort® Communicating products to automatically configure and control the heating/cooling system (based on user-specified settings) for the highest level of comfort, performance and efficiency
- Recognizes model and serial number information for iComfort® Communicating products to simplify system setup
- Wi-Fi remote temperature monitoring and adjustment through a home wireless network for desktop PCs, laptops and apps for smartphones or tablets
- Smart home automation compatible with Apple HomeKit™, Amazon Alexa®, Google Assistant and IFTTT
- Service alerts and reminders sent via text message or e-mail
- Service Dashboard features online real-time monitoring of installed iComfort® Communicating systems
- Simple easy-to-use touchscreen allows complete system configuration
- Scheduled maintenance alerts, system warnings and troubleshooting are also displayed on thermostat screen
- Easy to read 7 inch high definition color display (measured diagonally)
- Conventional outdoor units (not iComfort® Communicating) can easily be added and controlled by the iComfort® S30 Thermostat
- Installer setup screens allow quick and simple system configuration without a manual, Installer can also run tests on complete system or individual components for easy maintenance and troubleshooting
- Serial communications bus (RSBus), with less wiring than a conventional heating/cooling system, allows system communication
- Uses 4-wire, standard thermostat wiring
- High Definition Color Display with Subbase, Smart Hub Controller, wallplate (for retrofit installations) furnished for easy installation



NOTE - See the iComfort® S30 Thermostat Product Specifications bulletin in the Controls section for more information

Remote Outdoor Temperature Sensor

- Used with the iComfort® S30 Smart Wi-Fi Thermostat
- Outdoor sensor allows thermostat to display outdoor temperature
- Automatically detected when connected to thermostat



NOTE - Sensor is required for the Enhanced Dehumidification Accessory (EDA).

NOTE - Sensor is furnished as standard with iComfort® Communicating outdoor units, optional for conventional units.

Thermostat

- Thermostat is not furnished with unit
- See Lennox Price Book for selection

Night Service Kit

- Contains most commonly used service parts:
 - Furnace Control
 - Igniter
 - Flame Sensor
 - Gas Valve

CABINET

- Low-profile, narrow width allows easy installation
- Heavy-gauge, cold rolled steel construction
- Pre-painted finish
- Flue outlet on top of cabinet for upflow applications, can be relocated to either side of cabinet for horizontal applications
- Flanges provided on supply air opening for ease of plenum connection or alignment with indoor coil
- 10 • Insulated with foil faced insulation on sides and back of heating compartment and mat faced insulation in blower compartment
- Sealed blower compartment.
- Inner blower compartment access panel seals blower compartment from air leakage
- Cabinet door can be removed without any tools
- Complete service access
- 11 • Safety interlock switch automatically shuts off power to unit when inner blower compartment access panel is removed
- 12 • Gas piping and electrical inlets are provided in both sides of cabinet

FEATURES

CABINET (continued)

Bottom/Side Return Air Entry

- Upflow/horizontal with bottom return air entry:
 - Remove furnished bottom seal panel from cabinet
- Upflow only with side return-air entry:
 - Corners are marked on either side of cabinet for return air cut-out
- See dimension drawings

NOTE - 60C and 60D size units that require air volumes over 1800 cfm must have one of the following:

- Single side return air and Optional Return Air Base with transition that must accommodate required 20 x 25 x 1 inch air filter to maintain proper velocity
- Bottom return air
- Return air from both sides
- Bottom and one side return air

NOTE - See Blower Performance Tables for additional information.

Coil Match-Up

- All furnaces exactly match Lennox cased upflow indoor coils and horizontal indoor coils with same letter designation (A, B, C, D) in model number
- No adaptor required
- Engaging holes furnished on cabinet for alignment
- Lennox uncased coils match furnaces without any overhang but require an optional adaptor base or field fabricated transition to match furnace opening
- See coil bulletin for additional information

Low Leakage Cabinet

- All models have less than 2% air leakage
- Meets ANSI/ASHRAE Standard 193-2010 "Method of Test for Determining the Air Tightness of HVAC Equipment"

Optional Accessories

Horizontal Suspension Kit

- Provides suspension of unit and indoor coil in horizontal applications
- Allows complete service access
- Consists of corner mounted hanging brackets with vibration isolators, return air end support rail and hardware for assembly
- Metal hanging straps must be field provided

Return Air Base

NOTE - On furnaces with side return air and condensate trap on the same side of the cabinet, a field fabricated transition or Return Air Base is required when using an IAQ product higher than 14-3/16 inches installed next to the unit and serviced from the front. IAQ products higher than 20 inches require a field fabricated transition.

NOTE - Must be used for 60C and 60D size models with air volumes over 1800 cfm in upflow applications when only one side return is required.

- Cabinet is shipped flat for easy field assembly
- Pre-painted steel to match the furnace
- See Dimension Drawing

High Performance Economizer (Commercial Applications Only)

- Designed for applications requiring outdoor air to be utilized in a commercial HVAC system
- Allows the entry of fresh outdoor air for free cooling, reducing the requirement for mechanical cooling
- Heavy gauge galvanized steel cabinet lined with thick fiberglass insulation
- Mixed air sensor, outdoor air sensor and 24VAC transformer furnished
- Approved for California Title 24 building standards
- ASHRAE 90.1-2010 compliant
- See separate Product Specifications bulletin for additional information and available control and sensor options

NOTE - Economizer is not iComfort® compatible.

FILTER (not furnished)

- Filter and provisions for external mounting must be field provided

Optional Accessories

Air Filter and Rack Kit for Horizontal Return Air (End) Applications

- Washable or vacuum cleanable polyurethane frame type filter and external end return air rack available for field installation
- Rack has filter door for easy filter servicing
- Flanges on rack allow easy duct connection
- See dimension drawing

Air Filter and Rack Kit for Upflow Side Return Air

- Applications - Not for use with Return Air Base
- Washable or vacuum cleanable polyurethane frame type filter and external side return air rack available for field installation
- Available in single and ten pack kits
- Rack has filter door for easy filter servicing
- Flanges on rack allow easy duct connection
- Field installs on either side of unit cabinet
- See dimension drawing

99% WINTER DESIGN TEMPERATURES FOR THE CONTIGUOUS UNITED STATES



This map is a necessarily generalized guide to temperatures in the contiguous United States. Temperatures shown for areas such as mountainous regions and large urban centers may not be accurate. The data used to develop this map was taken from the 1993 ASHRAE Fundamentals Handbook (Chapter 24, Table 1: Climate Conditions for the United States).

Reprinted with permission from NFPA 54: National Fuel Gas Code 1999, National Fire Protection Association, Quincy, MA 02269. This reprinted material is not the complete and official position of the National Fire Protection Association on the referenced subject, which is represented only by the standard in its entirety.

INSTALLATION CLEARANCES

UPFLOW POSITION

Vent Type	Type B1	Type C
Sides	0 (0)	¹ 0 (0)
Rear	0 (0)	0 (0)
Top	1 (25)	1 (25)
Front	2-1/4 (57)	2-1/4 (57)
Front (service/alcove)	24 (610)	24 (610)
Floor	Combustible	Combustible
Flue	1 (25)	6 (152)

NOTE - Air for combustion must conform to the methods outlined in the National Fuel Gas Code (NFPA 54/ANSI-Z223.1).

NOTE - In the U.S. flue sizing must conform to the methods outlined in the current National Fuel Gas Code (NFPA 54/ANSI-Z223.1) or applicable provisions of local building codes.

¹ Left side requires 4 in. if single wall vent is used on 14-1/2 in. cabinets, 2 in. on 17-1/2 in. cabinets.

HORIZONTAL POSITION

Vent Type	Type B1	Type C
End	¹ 2 (51)	¹ 2 (51)
Rear	0 (0)	0 (0)
Top	¹ 0 (0)	¹ 0 (0)
Front	2-1/4 (57)	2-1/4 (57)
Front (service)	24 (610)	24 (610)
Floor	Combustible	Combustible
Flue	1 (25)	6 (152)

NOTE - Air for combustion must conform to the methods outlined in the National Fuel Gas Code (NFPA 54/ANSI-Z223.1).

NOTE - In the U.S. flue sizing must conform to the methods outlined in the current National Fuel Gas Code (NFPA 54/ANSI-Z223.1) or applicable provisions of local building codes.

¹ Line contact installation permissible between jacket top or sides and building joists.

SPECIFICATIONS

Gas Heating Performance	Model No.	SL280UH070V36A	SL280UH090V36B	SL280UH090V48B
	Model No. - Low Nox	SL280UH070XV36A	- - -	SL280UH090XV48B
	¹ AFUE	80%	80%	80%
High Fire	Input - Btuh	66,000	88,000	88,000
	Output - Btuh	52,000	70,000	70,000
	Temperature rise range - °F	40 - 70	40 - 70	40 - 70
	Gas Manifold Pressure (in. w.g.) Nat. Gas / LPG/Propane	3.5 / 10	3.5 / 10	3.5 / 10
Low Fire	Input - Btuh	43,000	57,000	57,000
	Output - Btuh	35,000	47,000	47,000
	Temperature rise range - °F	25 -55	25 -55	25 -55
	Gas Manifold Pressure (in. w.g.) Nat. Gas / LPG/Propane	1.7 / 4.5	1.7 / 4.5	1.7 / 4.5
High static - in. w.g.	Heating	0.8	0.8	0.8
	Cooling	1.0	1.0	1.0
Connections in.	Flue connection – in. round	4	4	4
	Gas pipe size IPS	1/2	1/2	1/2
Indoor Blower	Wheel nominal diameter x width - in.	10 X 8	10 X 9	11-1/2 X 9
	Motor output - hp	1/2	1/2	1.0
	Tons of add-on cooling	2 - 3	2 - 3.5	2.5 - 4
	Air Volume Range - cfm	606 - 1345	498 - 1393	679 - 2002
Electrical Data	Voltage	120 volts - 60 hertz - 1 phase		
	Blower motor full load amps	7.7	7.7	12.8
	Maximum overcurrent protection	15	15	20
Shipping Data	lbs. - 1 package	128	143	154

NOTE - Filters and provisions for mounting are not furnished and must be field provided.

¹ Annual Fuel Utilization Efficiency based on DOE test procedures and according to FTC labeling regulations. Isolated combustion system rating for non-weatherized furnaces.

² Flue connection on the unit is 4 in. diameter. Most applications will require 5 in. venting and field supplied 4 x 5 in. adaptor. See Venting Tables in the Installation Instructions for detailed information.

SPECIFICATIONS

Gas Heating Performance	Model No.	SL280UH090V60C	SL280UH110V60C	SL280UH135V60D
	Model No. - Low Nox	SL280UH090XV60C	SL280UH110XV60C	- - -
	¹ AFUE	80%	80%	80%
High Fire	Input - Btuh	88,000	110,000	132,000
	Output - Btuh	70,000	87,000	105,000
	Temperature rise range - °F	35 - 65	35 - 65	40 - 70
	Gas Manifold Pressure (in. w.g.) Nat. Gas / LPG/Propane	3.5 / 10.0	3.5 / 10.0	3.5 / 10.0
Low Fire	Input - Btuh	57,000	72,000	86,000
	Output - Btuh	47,000	58,000	69,000
	Temperature rise range - °F	25 -55	25 -55	25 -55
	Gas Manifold Pressure (in. w.g.) Nat. Gas / LPG/Propane	1.7 / 4.5	1.7 / 4.5	1.7 / 4.5
High static - in. w.g.	Heating	0.8	0.8	0.8
	Cooling	1.0	1.0	1.0
Connections in.	Flue connection – in. round	4	4	² 4
	Gas pipe size IPS	1/2	1/2	1/2
Indoor Blower	Wheel nominal diameter x width - in.	11-1/2 X 10	11-1/2 X 10	11-1/2 X 11
	Motor output - hp	1.0	1.0	1.0
	Tons of add-on cooling	3 - 5	3 - 5	3.5 - 5
	Air Volume Range - cfm	826 - 2305	812 - 2125	828 - 2257
Electrical Data	Voltage	120 volts - 60 hertz - 1 phase		
	Blower motor full load amps	12.8	12.8	12.8
	Maximum overcurrent protection	20	20	20
Shipping Data	lbs. - 1 package	173	181	199

NOTE - Filters and provisions for mounting are not furnished and must be field provided.

¹ Annual Fuel Utilization Efficiency based on DOE test procedures and according to FTC labeling regulations. Isolated combustion system rating for non-weatherized furnaces.

² Flue connection on the unit is 4 in. diameter. Most applications will require 5 in. venting and field supplied 4 x 5 in. adaptor. See Venting Tables in the Installation Instructions for detailed information.

OPTIONAL ACCESSORIES - ORDER SEPARATELY

NOTE - FURNACES CANNOT BE TWINNED!

		"A" Width Models	"B" Width Models	"C" Width Models	"D" Width Models
CABINET ACCESSORIES					
Horizontal Suspension Kit - Horizontal only		51W10	51W10	51W10	51W10
Return Air Base - Upflow only		65W75	50W98	50W99	51W00
High Performance Economizer (Commercial Only)		10U53	10U53	10U53	10U53
CONTROLS					
iComfort® S30 Ultra-Smart Wi-Fi Thermostat		12U67	12U67	12U67	12U67
¹ Discharge Air Temperature Sensor		88K38	88K38	88K38	88K38
iComfort® M30 Smart Wi-Fi Thermostat		15Z69	15Z69	15Z69	15Z69
² Remote Outdoor Air Temperature Sensor (for dual fuel and Humiditrol®)		X2658	X2658	X2658	X2658
FILTERS					
³ Air Filter and Rack Kit	Horizontal (end)	87L95	87L96	87L97	87L98
	Size of filter - in.	14 x 25 x 1	18 x 25 x 1	20 x 25 x 1	25 x 25 x 1
	Side Return	44J22	44J22	44J22	44J22
	Single	66K63	66K63	66K63	66K63
	Ten Pack	16 x 25 x 1	16 x 25 x 1	16 x 25 x 1	16 x 25 x 1
NIGHT SERVICE KIT					
Night Service Kit		16S36	16S36	16S36	16S36
VENTING					
Vent Adaptor – 6 in. conn. size upflow applications only		18M79	18M79	18M79	18M79

¹ Optional for service diagnostics.

² Remote Outdoor Air Temperature Sensor is used with conventional (non-iComfort® Communicating) outdoor units (sensor is furnished with iComfort® Communicating outdoor units). Allows the thermostat to display outdoor temperature. Required in dual-fuel and EDA applications.

³ Cleanable polyurethane, frame-type filter.

GAS HEAT ACCESSORIES

Input	High Altitude Pressure Switch Kit			Natural Gas to LPG/Propane Kit	LPG/Propane to Natural Gas Kit	Natural Gas High Altitude Orifice Kit	LPG/Propane High Altitude Orifice Kit
	0 - 4500 ft.	4501 - 7500 ft.	7501 - 10,000 ft.	0 - 7500 ft.	0 - 7500 ft.	7501- 10,000 ft.	7501- 10,000 ft.
070	No Change	No Change	73W35	11K51	77W09	73W37	11K46
090	No Change	69W56	73W35	11K51	77W09	73W37	11K46
110	No Change	69W56	73W35	11K51	77W09	73W37	11K46
135	No Change	73W33	73W34	11K51	77W09	73W37	11K46

HIGH ALTITUDE DERATE

NOTE - Units may be installed at altitudes up to 4500 ft. above sea level without any modifications.

At altitudes above 4500 ft. units must be derated to match information in the shaded area shown below.

NOTE - This is the only permissible derate for these units.

Input	Gas Manifold Pressure (Outlet) in. w.g.											
	0 - 4500 Feet				4501 -7500 Feet				7501 - 10,000 ft.			
	Natural Gas		LPG/Propane		Natural Gas		LPG/Propane		¹ Natural Gas		LPG/Propane	
	High Fire	Low Fire	High Fire	Low Fire	High Fire	Low Fire	High Fire	Low Fire	High Fire	Low Fire	High Fire	Low Fire
070	3.5	1.7	10	4.5	3.4	1.6	10	4.5	3.5	1.7	10	4.5
090	3.5	1.7	10	4.5	3.2	1.5	10	4.5	3.5	1.7	10	4.5
110	3.5	1.7	10	4.5	3.2	1.5	10	4.5	3.5	1.7	10	4.5
135	3.5	1.7	10	4.5	2.8	1.6	10	4.5	3.5	1.7	10	4.5

¹ Natural Gas High Altitude Orifice Kit required.

DIMENSIONS - UPFLOW POSITION

¹ NOTE - 60C and 60D size units that require air volumes over 1800 cfm must have one of the following:

1. Single side return air and Optional Return Air Base with transition that must accommodate required 20 x 25 x 1 inch (508 x 635 x 25 mm) air filter to maintain proper velocity.
 2. Bottom return air.
 3. Return air from both sides.
 4. Bottom and one side return air.
- See Blower Performance Tables for additional information.

² Flue outlet may be horizontal but furnace must be vented vertically

³ Optional External Side Return Air Filter Kit is not for use with the optional Return Air Base.

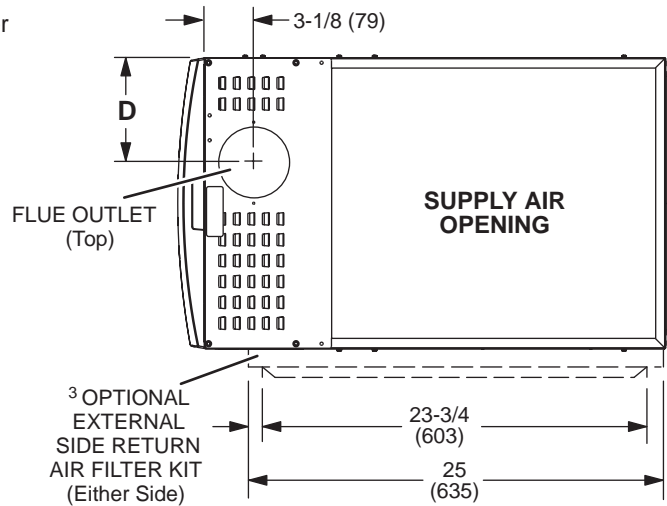

TOP VIEW

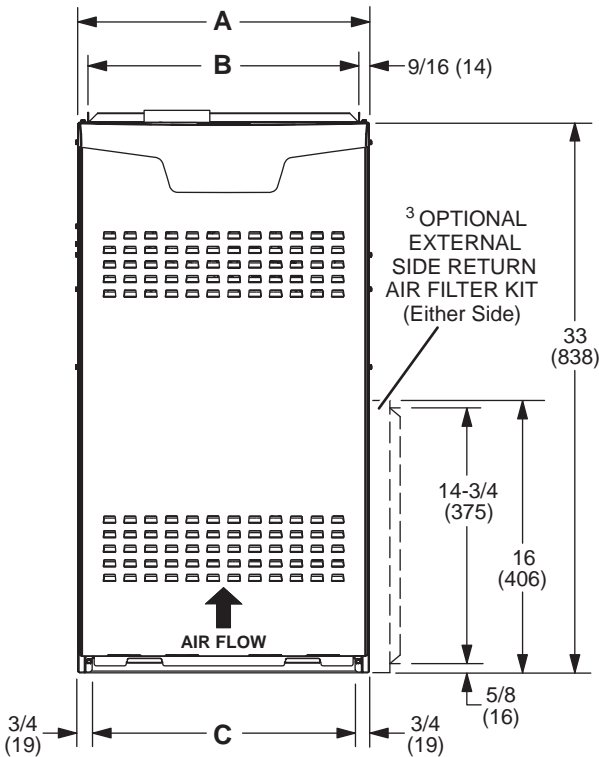

FRONT VIEW

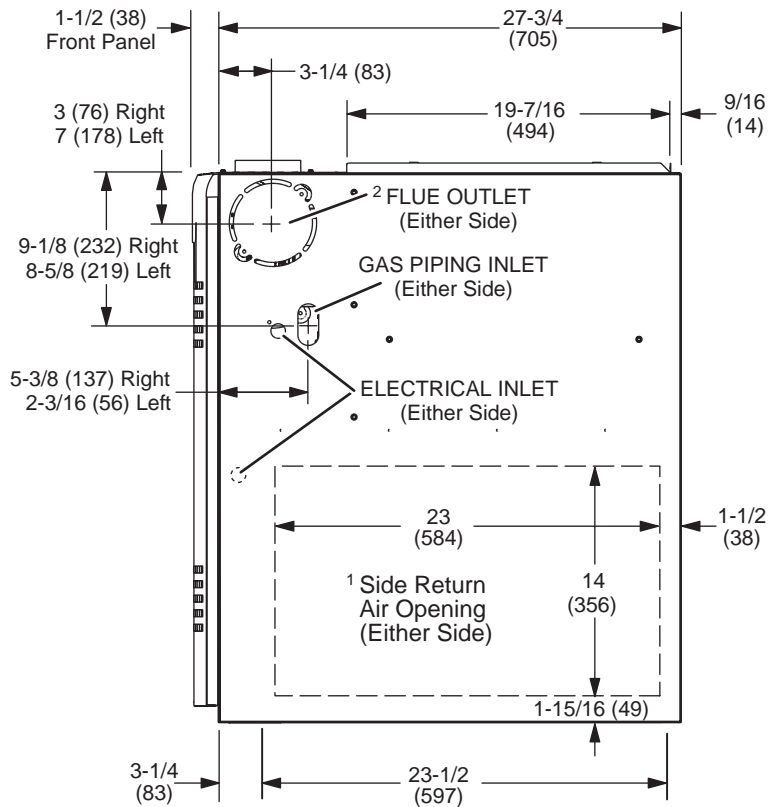

SIDE VIEW

Model No.	A		B		C		D	
	in.	mm	in.	mm	in.	mm	in.	mm
SL280UH070V36A	14-1/2	368	13-3/8	340	13	330	4-3/4	121
SL280UH090V36B	17-1/2	446	16-3/8	416	16	406	6-1/4	159
SL280UH090V48B								
SL280UH090V60C	21	533	19-7/8	504	19-1/2	495	8	203
SL280UH110V60C								
SL280UH135V60D	24-1/2	622	23-3/8	594	23	584	9-3/4	248

DIMENSIONS - HORIZONTAL POSITION

LEFT-HAND AIR DISCHARGE

¹ Flue outlet may be from end but furnace must be vented vertically

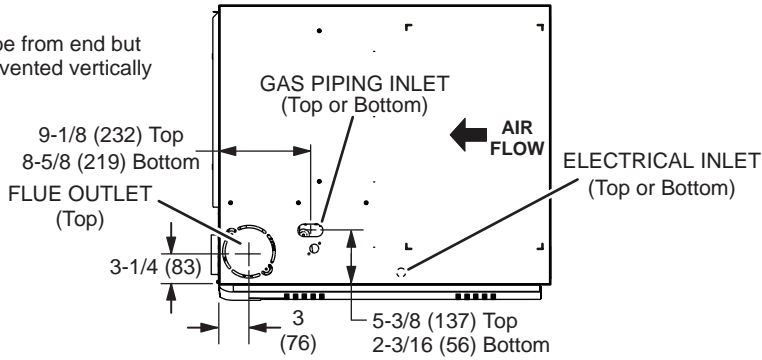

TOP VIEW

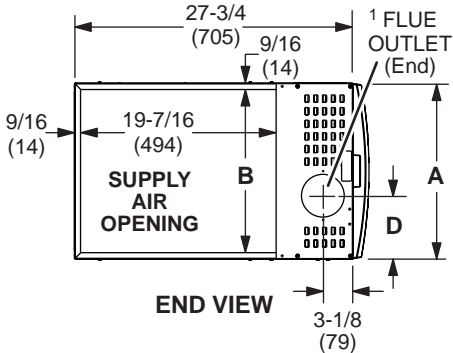

END VIEW

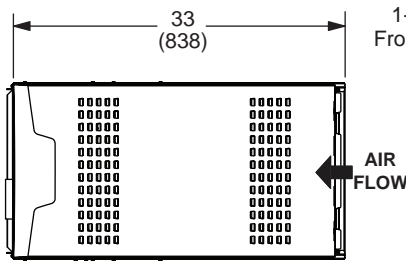

FRONT VIEW

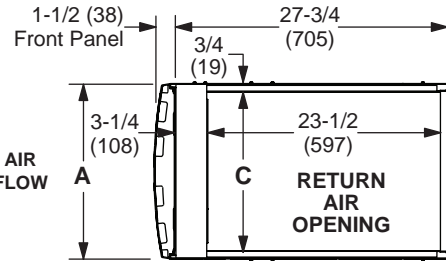

END VIEW

RIGHT-HAND AIR DISCHARGE

¹ Flue outlet may be horizontal but furnace must be vented vertically

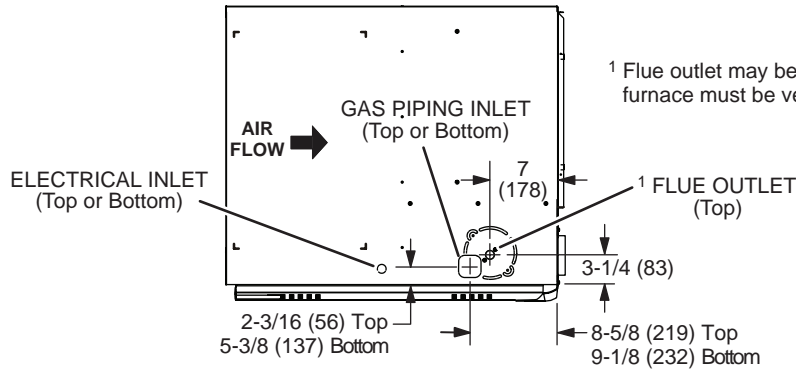

TOP VIEW

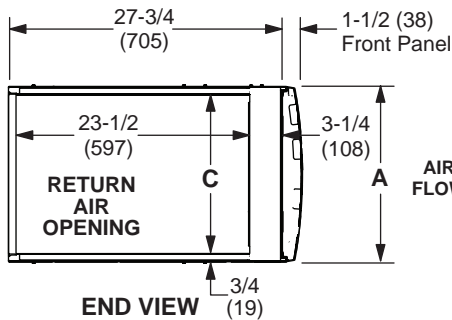

END VIEW

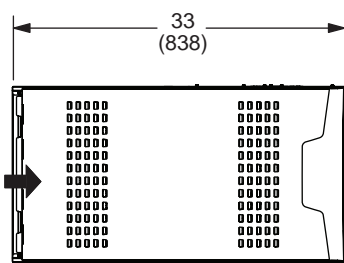

FRONT VIEW

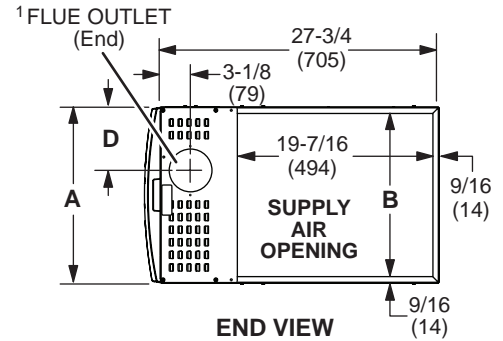

END VIEW

Model No.	A		B		C		D	
	in.	mm	in.	mm	in.	mm	in.	mm
SL280UH070V36A	14-1/2	368	13-3/8	340	13	330	4-3/4	121
SL280UH090V36B	17-1/2	446	16-3/8	416	16	406	6-1/4	159
SL280UH090V48B								
SL280UH090V60C	21	533	19-7/8	504	19-1/2	495	8	203
SL280UH110V60C								
SL280UH135V60D	24-1/2	622	23-3/8	594	23	584	9-3/4	248

DIMENSIONS - OPTIONAL ACCESSORIES

HORIZONTAL (END) FILTER KIT

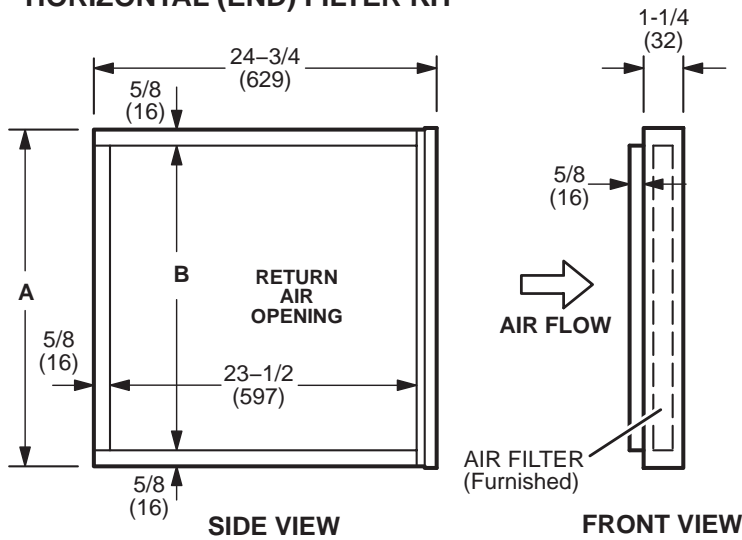

Furnace Cabinet Width	Catalog Number	A		B	
		in.	mm	in.	mm
A	87L95	14	356	12-3/4	324
B	87L96	18	457	16-3/4	425
C	87L97	21	533	18-3/4	476
D	87L98	25	635	23-3/4	603

Optional Return Air Base (Upflow Applications Only - For use with A, B, C and D cabinets)

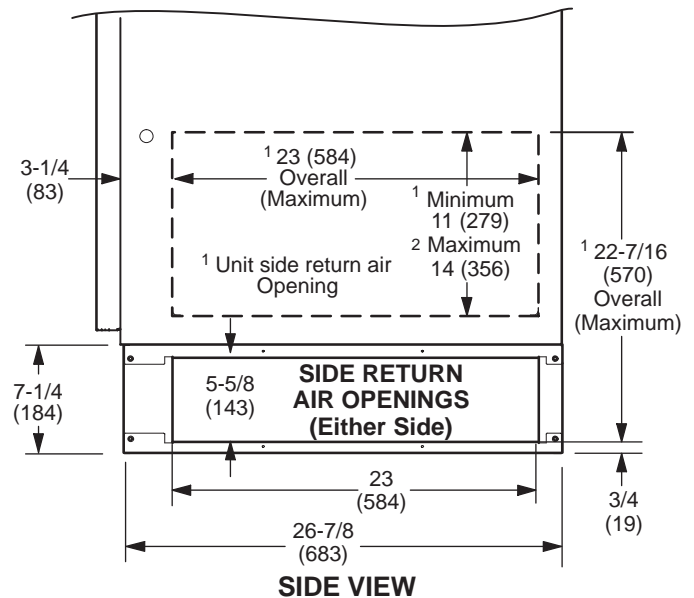
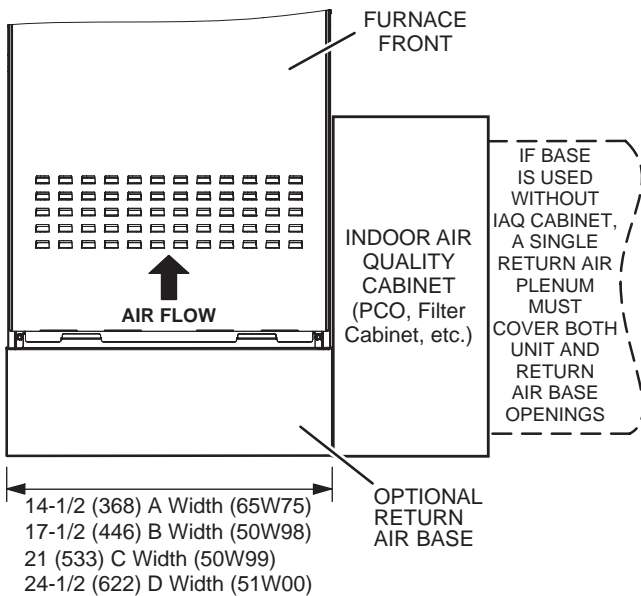

NOTE - Optional Side Return Air Filter Kits are not for use with Optional Return Air Base.

- ¹ Both the unit return air opening and the base return air opening must be covered by a single plenum or IAQ cabinet. Minimum unit side return air opening dimensions for units requiring 1800 cfm or more of air (W x H): 23 x 11 in. (584 x 279 mm). The opening can be cut as needed to accommodate plenum or IAQ cabinet while maintaining dimensions shown. Side return air openings must be cut in the field. There are cutting guides stenciled on the cabinet for the side return air opening. The size of the opening must not extend beyond the markings on the furnace cabinet.
- ² To minimize pressure drop, the largest opening height possible, up to 14 in. (356 mm), is preferred.

DIMENSIONS - FURNACE/COIL COMBINED DIMENSIONS

UPFLOW POSITION

Model No	C35/CX35 Cased				C35 Uncased			
	A		B		A		B	
C35/CX35	in.	mm	in.	mm	in.	mm	in.	mm
C35/CX35-18/24A C35/CX35-18/24B	16-1/2	419	49-1/2	1257	14-1/8	359	47-1/8	1197
C35/CX35-24A C35/CX35-24B	18-1/2	470	51-1/2	1308	16-3/8	416	49-3/8	1254
---	20-1/2	521	53-1/2	1359	---	---	---	---
C35/CX35-30A C35/CX35-30B	22-1/2	572	55-1/2	1410	20-3/4	527	53-3/4	1365
C35/CX35-30/36A C35/CX35-30/36B C35/CX35-30/36C	24-1/2	622	57-1/2	1461	22-1/4	565	55-1/4	1403
C35/CX35-36A C35/CX35-36B	24-1/2	622	57-1/2	1461	22-3/8	568	55-3/8	1407
---	24-1/2	622	57-1/2	1461	---	---	---	---
C35/CX35-48B C35/CX35-48C	27-1/2	699	60-1/2	1537	26-1/4	667	59-1/4	1505
---	24-1/2	622	57-1/2	1461	---	---	---	---
C35/CX35-49C	29-1/2	749	62-1/2	1588	28-1/2	724	61-1/2	1562
C35/CX35-50/60C	27-1/2	699	60-1/2	1537	25-7/8	657	58-7/8	1495
---	25-1/2	648	58-1/2	1486	---	---	---	---
CX35-60C	31-1/2	800	64-1/2	1638	30-5/8	778	63-5/8	1616
CX35-60D	29-1/2	749	62-1/2	1588	28	711	61	1549

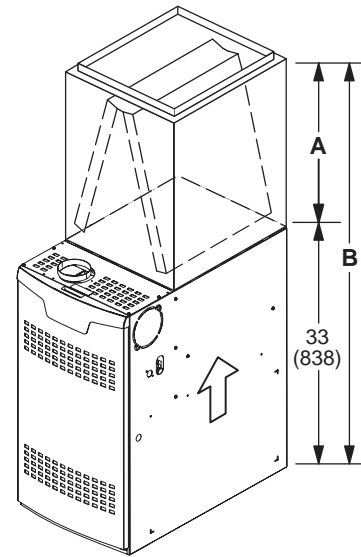

HORIZONTAL POSITION

Model No.		A		B	
		in.	mm	in.	mm
CH35					
CH35-18A, CH35-24A, CH35-24B, CH35-30B,	CH35-36A, CH35-36B, CH35-36C, CH35-42C, CH35-48C	26-1/2	673	59-1/2	1511
CH35-30A, CH35-42B, CH35-48B,	CH35-51C	31-1/2	880	64-1/2	1638
CHX35					
CHX35-18A, CHX35-24A, CHX35-24B, CHX35-30B,	CHX35-36A, CHX35-36B, CHX35-36C, CHX35-42C, CHX35-48C	26-1/2	673	59-1/2	1511
CHX35-30A, CHX35-42B, CHX35-48B,	CHX35-51/61C, CHX35-60D	31-1/2	880	64-1/2	1638

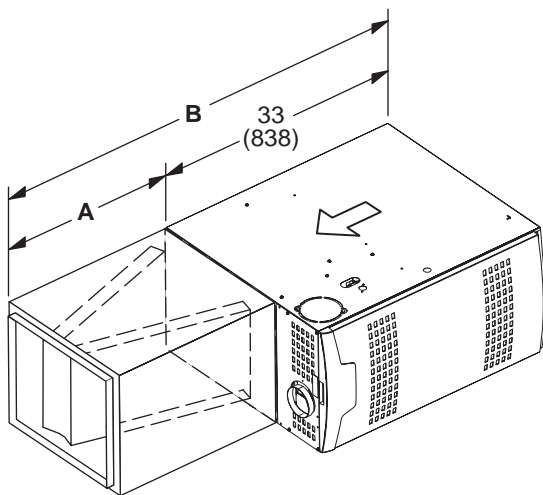

BLOWER DATA

SL280UH070V36A BLOWER PERFORMANCE (less filter)

BOTTOM RETURN AIR

0 through 0.8 in. w.g. (Heating) and 0 through 1.0 in. w.g. (Cooling) External Static Pressure Range

HEATING

¹ Heating Speed DIP Switch Settings	First Stage Heating Speed - cfm	Second Stage Heating Speed - cfm
+24%	1045	1145
+18%	985	1080
+12%	940	1035
+6%	880	960
Factory Default	850	925
-6%	785	875
-12%	745	815
-18%	680	745

COOLING

¹ Cooling Speed DIP Switch Settings	First Stage Cooling Speed - cfm				Second Stage Cooling Speed - cfm			
	Low	Medium-Low	Medium-High	² High	Low	Medium-Low	Medium-High	² High
+	781	819	872	981	1045	1139	1219	1372
Factory Default	695	734	797	883	943	1005	1114	1260
-	645	674	720	815	847	922	991	1144

¹ Cooling and heating speeds are based on a combination of DIP switch settings on the furnace control. Refer to Installation Instructions for specific DIP Switch Settings.

² Factory default setting.

NOTES - The effect of static pressure is included in air volumes shown.

First stage HEAT is approximately 91% of the same second stage HEAT.

First stage COOL (two-stage air conditioning units only) is approximately 70% of the same second stage COOL speed position.

Continuous Fan Only speed is selectable at 28% and 38% of the selected second stage cooling speed - minimum 250 cfm.

Lennox iHarmony® Zoning System Applications - Minimum blower speed is 250 cfm.

SL280UH070V36A BLOWER MOTOR WATTS (COOLING)

¹ Cooling Speed DIP Switch Settings	Motor Watts @ Various External Static Pressures - in. wg.																				
	First Stage										Second Stage										
	0	0.1	0.2	0.3	0.4	0.5	0.6	0.7	0.8	0	0.1	0.2	0.3	0.4	0.5	0.6	0.7	0.8	0.9	1.0	
+ Setting																					
Cooling Speed	Low	32	55	70	94	111	131	152	174	194	100	123	144	170	196	232	260	266	299	306	343
	Med-Low	43	66	87	103	128	147	167	190	217	134	153	185	211	241	266	291	316	342	367	384
	Med-High	53	74	97	120	143	165	184	209	228	181	198	234	261	289	316	342	367	390	411	436
	High	77	101	123	148	175	194	218	242	266	259	282	318	339	375	402	430	457	489	507	536
Factory Default																					
Cooling Speed	Low	26	44	61	78	94	114	138	152	163	66	86	112	139	160	174	199	223	247	270	296
	Med-Low	27	49	66	83	106	126	147	169	182	87	107	134	158	182	206	232	258	274	302	319
	Med-High	37	57	78	104	122	138	167	186	203	127	150	173	207	237	267	288	313	340	360	390
	High	60	85	101	123	148	167	193	211	236	197	218	249	277	306	333	358	388	412	434	454
- Setting																					
Cooling Speed	Low	19	34	54	69	86	105	119	144	149	45	66	91	105	138	150	176	189	213	237	266
	Med-Low	23	41	56	75	90	112	132	144	159	61	86	103	132	150	172	193	217	233	262	291
	Med-High	24	45	63	82	102	121	139	161	183	84	107	139	153	178	204	234	259	280	304	325
	High	38	59	81	104	123	145	170	188	208	136	158	190	213	236	268	290	318	339	367	390

BLOWER DATA

SL280UH070V36A BLOWER PERFORMANCE (less filter)

SINGLE SIDE RETURN AIR

0 through 0.8 in. w.g. (Heating) and 0 through 1.0 in. w.g. (Cooling) External Static Pressure Range

HEATING

¹ Heating Speed DIP Switch Settings	First Stage Heating Speed - cfm	Second Stage Heating Speed - cfm
+24%	1050	1165
+18%	1000	1110
+12%	940	1040
+6%	895	975
Factory Default	820	935
-6%	775	855
-12%	735	805
-18%	685	750

COOLING

¹ Cooling Speed DIP Switch Settings	First Stage Cooling Speed - cfm				Second Stage Cooling Speed - cfm			
	Low	Medium-Low	Medium-High	² High	Low	Medium-Low	Medium-High	² High
+	764	802	886	977	1035	1122	1248	1360
Factory Default	704	725	793	899	949	1029	1135	1257
-	642	680	717	812	874	933	1021	1133

¹ Cooling and heating speeds are based on a combination of DIP switch settings on the furnace control. Refer to Installation Instructions for specific DIP Switch Settings.

² Factory default setting.

NOTES - The effect of static pressure is included in air volumes shown.

First stage HEAT is approximately 91% of the same second stage HEAT.

First stage COOL (two-stage air conditioning units only) is approximately 70% of the same second stage COOL speed position.

Continuous Fan Only speed is selectable at 28% and 38% of the selected second stage cooling speed - minimum 250 cfm.

Lennox iHarmony® Zoning System Applications - Minimum blower speed is 250 cfm.

SL28UH070V36A BLOWER MOTOR WATTS (COOLING)

¹ Cooling Speed DIP Switch Settings	Motor Watts @ Various External Static Pressures - in. wg.																			
	First Stage										Second Stage									
	0	0.1	0.2	0.3	0.4	0.5	0.6	0.7	0.8	0	0.1	0.2	0.3	0.4	0.5	0.6	0.7	0.8	0.9	1.0

+ Setting

Cooling Speed	Low	36	54	73	95	113	130	147	170	186	90	112	138	159	190	213	236	263	284	305	329
	Med-Low	40	61	80	99	124	139	164	182	201	125	136	166	193	218	243	270	271	292	320	340
	Med-High	52	74	98	116	140	162	182	207	226	163	181	217	246	274	311	331	358	382	410	430
	High	77	100	123	144	165	187	213	234	259	236	259	290	327	354	381	413	448	467	496	519

Factory Default

Cooling Speed	Low	22	42	63	74	98	119	135	158	174	68	90	107	134	157	175	202	222	239	260	286
	Med-Low	30	49	68	83	111	126	139	160	184	86	109	135	153	178	204	232	258	273	292	321
	Med-High	32	53	74	92	116	136	154	177	199	115	137	165	197	221	247	272	300	326	348	370
	High	55	74	97	120	143	165	181	203	224	172	192	227	257	281	310	342	372	391	422	435

- Setting

Cooling Speed	Low	17	31	48	69	82	97	111	131	146	48	67	89	110	129	152	172	194	215	231	251
	Med-Low	22	43	57	74	84	109	130	140	163	62	84	103	124	151	173	196	212	233	258	277
	Med-High	28	49	64	78	104	117	136	156	176	87	112	132	151	180	203	228	251	273	292	317
	High	36	56	72	99	118	139	164	177	194	114	137	162	198	221	247	279	302	328	352	374

BLOWER DATA

SL280UH090V36B BLOWER PERFORMANCE (less filter)

BOTTOM RETURN AIR

0 through 0.8 in. w.g. (Heating) and 0 through 1.0 in. w.g. (Cooling) External Static Pressure Range

HEATING

¹ Heating Speed DIP Switch Settings	First Stage Heating Speed - cfm	Second Stage Heating Speed - cfm
+24%	1300	1420
+18%	1250	1335
+12%	1185	1285
+6%	1145	1240
Factory Default	1070	1170
-6%	1015	1100
-12%	970	1035
-18%	880	980

COOLING

¹ Cooling Speed DIP Switch Settings	First Stage Cooling Speed - cfm				Second Stage Cooling Speed - cfm			
	Low	Medium-Low	Medium-High	² High	Low	Medium-Low	Medium-High	² High
+	616	755	846	980	1018	1197	1291	1399
Factory Default	571	698	767	886	909	1083	1197	1284
-	489	627	681	812	834	968	1081	1179

¹ Cooling and heating speeds are based on a combination of DIP switch settings on the furnace control. Refer to Installation Instructions for specific DIP Switch Settings.

² Factory default setting.

NOTES - The effect of static pressure is included in air volumes shown.

First stage HEAT is approximately 91% of the same second stage HEAT.

First stage COOL (two-stage air conditioning units only) is approximately 70% of the same second stage COOL speed position.

Continuous Fan Only speed is selectable at 28% and 38% of the selected second stage cooling speed - minimum 250 cfm.

Lennox iHarmony® Zoning System Applications - Minimum blower speed is 250 cfm.

SL280UH090V36B BLOWER MOTOR WATTS (COOLING)

¹ Cooling Speed DIP Switch Settings	Motor Watts @ Various External Static Pressures - in. wg.																				
	First Stage										Second Stage										
	0	0.1	0.2	0.3	0.4	0.5	0.6	0.7	0.8	0	0.1	0.2	0.3	0.4	0.5	0.6	0.7	0.8	0.9	1.0	
+ Setting																					
Cooling Speed	Low	13	29	43	62	73	86	105	122	137	63	85	105	134	159	186	207	230	252	275	292
	Med-Low	27	46	64	84	102	119	137	159	177	112	136	157	193	224	247	277	300	321	350	372
	Med-High	43	59	80	104	119	143	159	178	191	145	163	199	233	264	289	316	345	374	397	417
	High	57	78	103	125	148	181	202	219	245	190	219	254	273	310	351	377	408	442	467	489
Factory Default																					
Cooling Speed	Low	12	25	42	55	65	86	93	115	123	51	70	97	113	139	155	176	199	221	242	261
	Med-Low	22	38	52	70	89	108	121	135	150	77	99	129	152	184	206	231	264	283	307	333
	Med-High	27	46	64	85	103	123	141	157	179	112	136	157	193	224	247	277	300	321	350	372
	High	51	68	90	110	136	150	172	198	211	145	164	197	232	257	290	320	351	362	396	411
- Setting																					
Cooling Speed	Low	9	21	35	45	60	74	89	100	119	41	59	80	96	116	136	159	176	195	204	230
	Med-Low	16	29	46	64	78	93	106	121	138	58	80	104	124	150	175	192	221	238	260	284
	Med-High	22	40	54	68	90	108	125	141	153	73	94	125	152	177	203	228	258	279	304	326
	High	36	53	72	91	112	131	150	169	185	99	125	154	182	207	234	266	296	320	344	369

BLOWER DATA

SL280UH090V36B BLOWER PERFORMANCE (less filter)

SINGLE SIDE RETURN AIR

0 through 0.8 in. w.g. (Heating) and 0 through 1.0 in. w.g. (Cooling) External Static Pressure Range

HEATING

¹ Heating Speed DIP Switch Settings	First Stage Heating Speed - cfm	Second Stage Heating Speed - cfm
+24%	1305	1425
+18%	1250	1350
+12%	1195	1290
+6%	1135	1230
Factory Default	1070	1165
-6%	995	1100
-12%	935	1030
-18%	870	960

COOLING

¹ Cooling Speed DIP Switch Settings	First Stage Cooling Speed - cfm				Second Stage Cooling Speed - cfm			
	Low	Medium-Low	Medium-High	² High	Low	Medium-Low	Medium-High	² High
+	611	731	830	971	995	1160	1274	1376
Factory Default	575	674	748	870	889	1075	1160	1270
-	519	604	691	786	808	952	1056	1147

¹ Cooling and heating speeds are based on a combination of DIP switch settings on the furnace control. Refer to Installation Instructions for specific DIP Switch Settings.

² Factory default setting.

NOTES - The effect of static pressure is included in air volumes shown.

First stage HEAT is approximately 91% of the same second stage HEAT.

First stage COOL (two-stage air conditioning units only) is approximately 70% of the same second stage COOL speed position.

Continuous Fan Only speed is selectable at 28% and 38% of the selected second stage cooling speed - minimum 250 cfm.

Lennox iHarmony® Zoning System Applications - Minimum blower speed is 250 cfm.

SL280UH090V36B BLOWER MOTOR WATTS (COOLING)

¹ Cooling Speed DIP Switch Settings	Motor Watts @ Various External Static Pressures - in. wg.																			
	First Stage										Second Stage									
	0	0.1	0.2	0.3	0.4	0.5	0.6	0.7	0.8	0	0.1	0.2	0.3	0.4	0.5	0.6	0.7	0.8	0.9	1.0

+ Setting

Cooling Speed	Low	10	27	41	57	72	88	105	123	135	55	82	99	123	148	173	199	220	244	266	290
	Med-Low	23	44	59	80	99	119	138	158	177	103	129	151	184	214	235	264	290	316	342	368
	Med-High	37	56	75	95	114	135	153	174	189	147	167	205	230	264	285	317	347	365	394	423
	High	54	81	95	120	144	170	191	217	234	189	219	249	273	312	339	379	404	431	459	485

Factory Default

Cooling Speed	Low	8	24	34	50	70	83	96	110	124	39	63	85	105	131	147	174	193	214	243	264
	Med-Low	16	36	50	68	86	106	121	144	159	73	92	123	148	173	203	221	249	266	297	317
	Med-High	23	43	61	81	106	123	144	160	182	103	129	151	184	214	235	264	290	316	342	368
	High	43	62	88	107	123	145	169	189	209	149	170	199	234	259	291	311	334	367	389	412

- Setting

Cooling Speed	Low	4	18	29	45	59	74	86	98	113	31	52	67	92	113	129	156	175	197	209	232
	Med-Low	11	29	44	58	79	93	111	129	141	50	76	97	116	141	159	185	206	235	250	282
	Med-High	15	36	52	67	86	108	126	144	161	68	89	121	139	167	192	219	243	269	292	310
	High	32	53	70	94	109	129	153	174	189	95	118	144	178	198	226	256	278	302	328	352

BLOWER DATA

SL280UH090V48B BLOWER PERFORMANCE (less filter)

BOTTOM RETURN AIR

0 through 0.8 in. w.g. (Heating) and 0 through 1.0 in. w.g. (Cooling) External Static Pressure Range

HEATING

¹ Heating Speed DIP Switch Settings	First Stage Heating Speed - cfm	Second Stage Heating Speed - cfm
+24%	1280	1410
+18%	1220	1340
+12%	1155	1270
+6%	1095	1205
Factory Default	1035	1135
-6%	970	1070
-12%	910	1000
-18%	845	930

COOLING

¹ Cooling Speed DIP Switch Settings	First Stage Cooling Speed - cfm				Second Stage Cooling Speed - cfm			
	Low	Medium-Low	Medium-High	² High	Low	Medium-Low	Medium-High	² High
+	670	890	1040	1210	1030	1335	1550	1755
Factory Default	605	815	965	1090	940	1205	1405	1,600
-	525	690	850	985	795	1060	1260	1435

¹ Cooling and heating speeds are based on a combination of DIP switch settings on the furnace control. Refer to Installation Instructions for specific DIP Switch Settings.

² Factory default setting.

NOTES - The effect of static pressure is included in air volumes shown.

First stage HEAT is approximately 91% of the same second stage HEAT.

First stage COOL (two-stage air conditioning units only) is approximately 70% of the same second stage COOL speed position.

Continuous Fan Only speed is selectable at 28% and 38% of the selected second stage cooling speed - minimum 380 cfm.

Lennox iHarmony® Zoning System Applications - Minimum blower speed is 380 cfm.

SL280UH090V48B BLOWER MOTOR WATTS (COOLING)

¹ Cooling Speed DIP Switch Settings	Motor Watts @ Various External Static Pressures - in. wg.																				
	First Stage										Second Stage										
	0	0.1	0.2	0.3	0.4	0.5	0.6	0.7	0.8	0	0.1	0.2	0.3	0.4	0.5	0.6	0.7	0.8	0.9	1.0	
+ Setting																					
Cooling Speed	Low	40	56	75	86	105	128	141	157	173	93	125	144	161	182	209	237	258	286	307	338
	Med-Low	64	86	105	122	146	169	187	207	227	167	196	240	262	299	328	367	398	433	467	492
	Med-High	93	119	141	163	189	213	237	261	286	259	287	321	374	410	451	481	518	555	581	611
	High	128	156	188	219	248	281	308	338	366	372	407	465	493	558	604	661	706	726	764	817
Factory Default																					
Cooling Speed	Low	35	51	64	79	92	107	122	138	159	81	105	122	139	159	186	200	221	247	263	286
	Med-Low	50	65	85	114	130	148	173	179	200	112	142	173	206	234	271	300	323	356	395	419
	Med-High	75	98	117	136	159	177	187	207	244	189	221	254	289	335	362	400	431	458	504	526
	High	98	122	149	180	194	230	252	278	300	288	321	372	398	433	470	507	554	598	623	653
- Setting																					
Cooling Speed	Low	32	44	57	71	82	95	107	121	132	74	94	112	130	147	174	189	206	226	245	264
	Med-Low	43	60	76	91	109	127	143	159	176	86	119	134	161	185	212	236	257	290	320	342
	Med-High	55	70	94	116	132	157	171	190	206	138	170	194	226	269	295	325	357	384	414	442
	High	80	100	123	147	166	187	210	231	253	204	235	269	312	342	376	425	450	482	516	546

BLOWER DATA

SL280UH090V48B BLOWER PERFORMANCE (less filter)

SINGLE SIDE RETURN AIR

0 through 0.8 in. w.g. (Heating) and 0 through 1.0 in. w.g. (Cooling) External Static Pressure Range

HEATING

¹ Heating Speed DIP Switch Settings	First Stage Heating Speed - cfm	Second Stage Heating Speed - cfm
+24%	1280	1410
+18%	1220	1340
+12%	1155	1270
+6%	1095	1205
Factory Default	1035	1135
-6%	970	1070
-12%	910	1000
-18%	845	930

COOLING

¹ Cooling Speed DIP Switch Settings	First Stage Cooling Speed - cfm				Second Stage Cooling Speed - cfm			
	Low	Medium-Low	Medium-High	² High	Low	Medium-Low	Medium-High	² High
+	640	900	1015	1175	1005	1295	1500	1670
Factory Default	570	780	930	1040	895	1160	1345	1500
-	530	700	810	955	795	1050	1210	1405

¹ Cooling and heating speeds are based on a combination of DIP switch settings on the furnace control. Refer to Installation Instructions for specific DIP Switch Settings.

² Factory default setting.

NOTES - The effect of static pressure is included in air volumes shown.

First stage HEAT is approximately 91% of the same second stage HEAT.

First stage COOL (two-stage air conditioning units only) is approximately 70% of the same second stage COOL speed position.

Continuous Fan Only speed is selectable at 28% and 38% of the selected second stage cooling speed - minimum 380 cfm.

Lennox iHarmony® Zoning System Applications - Minimum blower speed is 380 cfm.

SL280UH090V48B BLOWER MOTOR WATTS (COOLING)

¹ Cooling Speed DIP Switch Settings	Motor Watts @ Various External Static Pressures - in. wg.																			
	First Stage										Second Stage									
	0	0.1	0.2	0.3	0.4	0.5	0.6	0.7	0.8	0	0.1	0.2	0.3	0.4	0.5	0.6	0.7	0.8	0.9	1.0

+ Setting

Cooling Speed	Low	34	54	68	85	102	120	142	159	177	79	107	133	148	172	201	226	253	274	301	327
	Med-Low	64	85	105	124	145	166	186	206	227	151	179	214	247	276	312	339	370	399	433	464
	Med-High	85	112	135	157	184	208	233	258	284	230	261	305	348	379	421	453	490	523	565	602
	High	110	139	172	201	234	270	294	326	352	478	369	414	462	506	547	597	643	691	735	781

Factory Default

Cooling Speed	Low	30	46	59	77	87	106	118	143	152	70	93	115	134	153	172	195	219	242	260	286
	Med-Low	36	56	76	95	120	136	162	175	196	100	132	163	192	214	244	276	307	338	368	402
	Med-High	64	88	106	130	149	173	198	222	238	166	192	231	266	303	342	370	410	444	462	493
	High	87	118	141	161	194	223	248	275	302	245	273	333	365	396	432	460	503	546	579	635

- Setting

Cooling Speed	Low	28	43	53	70	83	97	110	120	135	53	72	88	112	133	150	175	191	205	230	245
	Med-Low	37	56	72	86	106	124	141	158	176	84	111	134	154	185	215	235	260	284	311	336
	Med-High	51	69	90	109	129	152	168	187	205	119	152	182	210	244	276	307	338	370	401	432
	High	71	94	119	138	158	181	207	233	250	180	211	248	284	316	355	385	419	450	487	521

BLOWER DATA

SL280UH090V48B BLOWER PERFORMANCE (less filter)

SIDE RETURN AIR WITH OPTIONAL RETURN AIR BASE

0 through 0.8 in. w.g. (Heating) and 0 through 1.0 in. w.g. (Cooling) External Static Pressure Range

HEATING

¹ Heating Speed DIP Switch Settings	First Stage Heating Speed - cfm	Second Stage Heating Speed - cfm
+24%	1295	1425
+18%	1235	1355
+12%	1170	1290
+6%	1110	1220
Factory Default	1045	1150
-6%	980	1080
-12%	920	1010
-18%	855	945

COOLING

¹ Cooling Speed DIP Switch Settings	First Stage Cooling Speed - cfm				Second Stage Cooling Speed - cfm			
	Low	Medium-Low	Medium-High	² High	Low	Medium-Low	Medium-High	² High
+	660	905	1030	1175	985	1290	1495	1675
Factory Default	600	760	930	1045	905	1125	1345	1525
-	535	700	850	970	815	1040	1225	1385

¹ Cooling and heating speeds are based on a combination of DIP switch settings on the furnace control. Refer to Installation Instructions for specific DIP Switch Settings.

² Factory default setting.

NOTES - The effect of static pressure is included in air volumes shown.

First stage HEAT is approximately 91% of the same second stage HEAT.

First stage COOL (two-stage air conditioning units only) is approximately 70% of the same second stage COOL speed position.

Continuous Fan Only speed is selectable at 28% and 38% of the selected second stage cooling speed - minimum 380 cfm.

Lennox iHarmony® Zoning System Applications - Minimum blower speed is 380 cfm.

SL280UH090V48B BLOWER MOTOR WATTS (COOLING)

¹ Cooling Speed DIP Switch Settings	Motor Watts @ Various External Static Pressures - in. wg.																				
	First Stage										Second Stage										
	0	0.1	0.2	0.3	0.4	0.5	0.6	0.7	0.8	0	0.1	0.2	0.3	0.4	0.5	0.6	0.7	0.8	0.9	1.0	
+ Setting																					
Cooling Speed	Low	34	54	65	84	101	122	138	156	169	75	104	128	146	170	193	224	244	266	300	326
	Med-Low	57	74	97	120	137	158	177	197	216	124	160	189	216	254	287	319	351	385	416	449
	Med-High	76	102	125	147	174	200	223	248	272	208	238	279	319	350	391	422	457	489	529	564
	High	106	134	165	193	224	259	283	313	340	302	346	386	426	470	510	554	596	640	680	722
Factory Default																					
Cooling Speed	Low	31	47	59	74	89	105	123	139	150	64	88	107	131	150	173	196	217	241	263	285
	Med-Low	43	61	82	101	118	144	158	177	194	94	123	150	183	213	243	279	300	331	353	393
	Med-High	62	85	104	130	151	173	196	216	239	150	180	219	250	294	333	368	399	428	463	497
	High	81	113	131	151	187	211	238	264	291	235	263	312	349	387	426	455	489	522	568	608
- Setting																					
Cooling Speed	Low	29	40	53	69	83	93	104	122	129	50	69	85	107	127	149	169	187	201	222	237
	Med-Low	32	50	66	84	101	116	136	153	172	78	105	126	146	174	199	223	247	272	295	319
	Med-High	46	65	86	109	127	146	167	187	207	105	135	166	195	227	262	289	319	348	380	411
	High	69	92	112	134	156	175	200	221	245	161	195	230	264	298	334	367	401	434	469	503

BLOWER DATA

SL280UH090V60C BLOWER PERFORMANCE (less filter)

BOTTOM RETURN AIR, RETURN AIR FROM BOTH SIDES OR RETURN AIR FROM BOTTOM AND ONE SIDE

0 through 0.8 in. w.g. (Heating) and 0 through 1.0 in. w.g. (Cooling) External Static Pressure Range

HEATING

¹ Heating Speed DIP Switch Settings	First Stage Heating Speed - cfm	Second Stage Heating Speed - cfm
+24%	1420	1565
+18%	1355	1490
+12%	1285	1415
+6%	1215	1335
Factory Default	1145	1260
-6%	1080	1185
-12%	1010	1110
-18%	940	1035

COOLING

¹ Cooling Speed DIP Switch Settings	First Stage Cooling Speed - cfm				Second Stage Cooling Speed - cfm			
	Low	Medium-Low	Medium-High	² High	Low	Medium-Low	Medium-High	² High
+	1110	1205	1420	1680	1575	1740	2000	2305
Factory Default	1005	1100	1280	1545	1440	1595	1820	2125
-	890	1015	1125	1380	1295	1450	1610	1930

¹ Cooling and heating speeds are based on a combination of DIP switch settings on the furnace control. Refer to Installation Instructions for specific DIP Switch Settings.

² Factory default setting.

NOTES - The effect of static pressure is included in air volumes shown.

First stage HEAT is approximately 91% of the same second stage HEAT.

First stage COOL (two-stage air conditioning units only) is approximately 70% of the same second stage COOL speed position.

Continuous Fan Only speed is selectable at 28% and 38% of the selected second stage cooling speed - minimum 450 cfm.

Lennox iHarmony® Zoning System Applications - Minimum blower speed is 450 cfm.

SL280UH090V60C BLOWER MOTOR WATTS (COOLING)

¹ Cooling Speed DIP Switch Settings	Motor Watts @ Various External Static Pressures - in. wg.																			
	First Stage										Second Stage									
	0	0.1	0.2	0.3	0.4	0.5	0.6	0.7	0.8	0	0.1	0.2	0.3	0.4	0.5	0.6	0.7	0.8	0.9	1.0

+ Setting

Cooling Speed	Low	89	113	136	159	182	204	228	251	275	218	245	291	327	372	398	436	474	505	532	579
	Med-Low	104	133	163	184	214	245	266	304	328	298	333	382	412	450	488	541	576	612	648	681
	Med-High	162	191	227	262	294	333	354	391	422	440	476	527	576	636	686	741	777	820	857	892
	High	279	316	355	394	432	473	509	547	584	772	808	877	946	1000	1056	1089	1146	1190	1255	1266

Factory Default

Cooling Speed	Low	70	92	108	134	159	174	196	215	242	160	195	228	265	291	340	364	397	442	469	500
	Med-Low	89	115	135	156	185	207	227	250	281	241	267	305	347	384	413	445	477	519	542	573
	Med-High	122	149	183	206	234	269	297	324	350	330	370	414	452	500	542	593	634	675	702	747
	High	214	241	277	318	350	388	423	449	469	553	591	655	713	781	819	868	922	967	1026	1066

- Setting

Cooling Speed	Low	54	70	91	110	129	154	166	185	200	107	151	177	206	245	272	298	332	398	423	449
	Med-Low	73	94	112	135	151	175	189	214	235	173	201	244	272	304	337	368	393	437	465	498
	Med-High	93	120	141	160	191	221	244	261	288	246	271	310	353	395	433	466	492	528	557	593
	High	149	185	217	251	284	314	352	386	422	410	456	505	543	595	635	692	729	777	829	867

BLOWER DATA

SL280UH090V60C BLOWER PERFORMANCE (less filter)

SINGLE SIDE RETURN AIR – Air volumes in bold require Optional Return Air Base and field fabricated transition to accommodate 20 x 25 x 1 in. air filter in order to maintain proper air velocity.

0 through 0.8 in. w.g. (Heating) and 0 through 1.0 in. w.g. (Cooling) External Static Pressure Range

HEATING

¹ Heating Speed DIP Switch Settings	First Stage Heating Speed - cfm	Second Stage Heating Speed - cfm
+24%	1360	1500
+18%	1295	1425
+12%	1230	1355
+6%	1165	1280
Factory Default	1100	1210
-6%	1030	1135
-12%	965	1065
-18%	900	990

COOLING

¹ Cooling Speed DIP Switch Settings	First Stage Cooling Speed - cfm				Second Stage Cooling Speed - cfm			
	Low	Medium-Low	Medium-High	² High	Low	Medium-Low	Medium-High	² High
+	1050	1165	1335	1620	1515	1680	1915	2225
Factory Default	955	1060	1215	1480	1390	1545	1735	2060
-	840	945	1090	1290	1220	1385	1580	1825

¹ Cooling and heating speeds are based on a combination of DIP switch settings on the furnace control. Refer to Installation Instructions for specific DIP Switch Settings.

² Factory default setting.

NOTES - The effect of static pressure is included in air volumes shown.

First stage HEAT is approximately 91% of the same second stage HEAT.

First stage COOL (two-stage air conditioning units only) is approximately 70% of the same second stage COOL speed position.

Continuous Fan Only speed is selectable at 28% and 38% of the selected second stage cooling speed - minimum 450 cfm.

Lennox iHarmony® Zoning System Applications - Minimum blower speed is 450 cfm.

SL280UH090V60C BLOWER MOTOR WATTS (COOLING)

¹ Cooling Speed DIP Switch Settings	Motor Watts @ Various External Static Pressures - in. wg.																				
	First Stage										Second Stage										
	0	0.1	0.2	0.3	0.4	0.5	0.6	0.7	0.8	0	0.1	0.2	0.3	0.4	0.5	0.6	0.7	0.8	0.9	1.0	
+ Setting																					
Cooling Speed	Low	75	104	122	142	163	189	214	239	264	219	243	283	317	363	384	424	441	484	511	543
	Med-Low	98	128	150	181	205	236	259	289	317	289	333	351	405	444	490	523	564	604	636	668
	Med-High	144	172	205	242	279	306	344	367	396	417	451	507	557	605	655	694	733	788	824	867
	High	245	272	307	359	386	421	447	473	520	709	743	795	855	906	955	1009	1049	1095	1131	1165
Factory Default																					
Cooling Speed	Low	66	88	109	127	150	165	189	209	236	157	185	219	259	290	328	353	394	425	452	480
	Med-Low	79	104	127	147	173	201	225	248	268	222	246	284	328	370	397	416	460	490	519	555
	Med-High	106	137	164	190	215	250	278	307	333	307	349	387	435	463	505	553	599	634	674	714
	High	192	224	260	298	338	365	400	438	467	563	597	664	717	756	820	881	907	972	1007	1039
- Setting																					
Cooling Speed	Low	44	65	80	103	121	142	163	180	199	114	141	173	200	230	259	289	318	347	374	401
	Med-Low	63	82	105	125	145	166	188	203	227	159	187	226	252	288	323	353	388	419	444	475
	Med-High	82	108	131	151	178	203	229	253	274	236	263	302	344	382	420	443	478	514	548	583
	High	127	159	187	213	252	281	305	338	371	361	393	450	494	537	586	616	672	711	752	787

BLOWER DATA

SL280UH110V60C BLOWER PERFORMANCE (less filter)

BOTTOM RETURN AIR, RETURN AIR FROM BOTH SIDES OR RETURN AIR FROM BOTTOM AND ONE SIDE

0 through 0.8 in. w.g. (Heating) and 0 through 1.0 in. w.g. (Cooling) External Static Pressure Range

HEATING

¹ Heating Speed DIP Switch Settings	First Stage Heating Speed - cfm				Second Stage Heating Speed - cfm			
	+24%	1690				1855		
+18%	1605				1765			
+12%	1525				1675			
+6%	1445				1585			
Factory Default	1360				1495			
-6%	1280				1405			
-12%	1200				1315			
-18%	1115				1230			

COOLING

¹ Cooling Speed DIP Switch Settings	First Stage Cooling Speed - cfm				Second Stage Cooling Speed - cfm			
	Low	Medium-Low	Medium-High	² High	Low	Medium-Low	Medium-High	² High
+	1060	1220	1330	1565	1535	1710	1910	2210
Factory Default	970	1075	1180	1430	1400	1565	1715	2015
-	875	980	1070	1255	1260	1400	1560	1815

¹ Cooling and heating speeds are based on a combination of DIP switch settings on the furnace control. Refer to Installation Instructions for specific DIP Switch Settings.

² Factory default setting.

NOTES - The effect of static pressure is included in air volumes shown.

First stage HEAT is approximately 91% of the same second stage HEAT.

First stage COOL (two-stage air conditioning units only) is approximately 70% of the same second stage COOL speed position.

Continuous Fan Only speed is selectable at 28% and 38% of the selected second stage cooling speed - minimum 450 cfm.

Lennox iHarmony® Zoning System Applications - Minimum blower speed is 450 cfm.

SL280UH110V60C BLOWER MOTOR WATTS (COOLING)

¹ Cooling Speed DIP Switch Settings	Motor Watts @ Various External Static Pressures - in. wg.																				
	First Stage										Second Stage										
	0	0.1	0.2	0.3	0.4	0.5	0.6	0.7	0.8	0	0.1	0.2	0.3	0.4	0.5	0.6	0.7	0.8	0.9	1.0	
+ Setting																					
Cooling Speed	Low	89	116	144	159	201	222	245	274	298	234	259	304	360	385	408	451	484	530	553	596
	Med-Low	108	135	170	196	228	259	286	320	343	297	340	380	409	459	502	539	570	616	660	702
	Med-High	136	164	202	236	269	300	331	370	392	390	420	497	530	585	630	677	727	777	815	854
	High	252	275	329	366	396	441	472	493	537	702	734	780	841	907	957	1013	1048	1100	1124	1148
Factory Default																					
Cooling Speed	Low	71	98	118	139	166	184	207	237	262	179	203	244	281	329	356	388	425	453	480	519
	Med-Low	86	118	138	154	187	212	237	266	291	223	251	288	342	377	399	449	474	513	548	578
	Med-High	99	132	160	184	222	254	277	308	343	299	341	384	420	472	497	540	599	632	674	709
	High	192	227	258	299	333	376	409	434	471	493	540	591	653	705	760	829	869	919	965	1005
- Setting																					
Cooling Speed	Low	60	78	104	122	144	168	187	205	226	133	162	191	225	262	289	324	357	385	410	436
	Med-Low	68	94	116	132	150	177	203	220	251	163	189	224	263	292	333	364	392	431	458	473
	Med-High	80	109	128	151	174	204	229	252	279	224	251	293	326	370	398	439	467	491	531	570
	High	131	165	196	226	265	300	336	356	397	365	406	460	511	558	603	643	705	743	792	835

BLOWER DATA

SL280UH110V60C BLOWER PERFORMANCE (less filter)

SINGLE SIDE RETURN AIR – Air volumes in **bold** require Optional Return Air Base and field fabricated transition to accommodate 20 x 25 x 1 in. air filter in order to maintain proper air velocity.

0 through 0.8 in. w.g. (Heating) and 0 through 1.0 in. w.g. (Cooling) External Static Pressure Range

HEATING

¹ Heating Speed DIP Switch Settings	First Stage Heating Speed - cfm	Second Stage Heating Speed - cfm
+24%	1640	1805
+18%	1560	1715
+12%	1480	1630
+6%	1400	1545
Factory Default	1325	1455
-6%	1245	1370
-12%	1165	1280
-18%	1085	1195

COOLING

¹ Cooling Speed DIP Switch Settings	First Stage Cooling Speed - cfm				Second Stage Cooling Speed - cfm			
	Low	Medium-Low	Medium-High	² High	Low	Medium-Low	Medium-High	² High
+	1020	1160	1285	1550	1505	1690	1855	2125
Factory Default	940	1050	1155	1400	1375	1525	1685	1935
-	835	945	1020	1250	1235	1380	1505	1730

¹ Cooling and heating speeds are based on a combination of DIP switch settings on the furnace control. Refer to Installation Instructions for specific DIP Switch Settings.

² Factory default setting.

NOTES - The effect of static pressure is included in air volumes shown.

First stage HEAT is approximately 91% of the same second stage HEAT.

First stage COOL (two-stage air conditioning units only) is approximately 70% of the same second stage COOL speed position.

Continuous Fan Only speed is selectable at 28% and 38% of the selected second stage cooling speed - minimum 450 cfm.

Lennox iHarmony® Zoning System Applications - Minimum blower speed is 450 cfm.

SL280UH110V60C BLOWER MOTOR WATTS (COOLING)

¹ Cooling Speed DIP Switch Settings	Motor Watts @ Various External Static Pressures - in. wg.																				
	First Stage										Second Stage										
	0	0.1	0.2	0.3	0.4	0.5	0.6	0.7	0.8	0	0.1	0.2	0.3	0.4	0.5	0.6	0.7	0.8	0.9	1.0	
+ Setting																					
Cooling Speed	Low	84	116	131	156	193	216	238	265	292	218	245	293	336	378	415	454	488	516	557	601
	Med-Low	99	128	156	195	216	245	280	309	335	292	333	381	412	454	490	535	577	618	662	704
	Med-High	128	157	193	226	266	293	321	360	387	373	412	475	518	573	617	661	710	771	800	857
	High	238	274	303	354	388	413	460	493	524	675	717	786	854	898	983	1017	1071	1112	1157	1186
Factory Default																					
Cooling Speed	Low	73	96	121	140	154	184	206	228	255	166	192	237	271	319	345	382	419	459	480	515
	Med-Low	81	108	133	156	175	207	230	253	285	220	248	290	328	372	405	447	474	513	540	577
	Med-High	92	123	148	185	209	246	277	302	331	290	328	374	415	452	487	536	576	605	653	701
	High	175	202	247	285	327	364	388	426	457	477	511	590	647	690	739	789	843	901	947	998
- Setting																					
Cooling Speed	Low	56	74	98	116	141	157	179	199	216	129	157	198	221	259	298	325	354	387	418	451
	Med-Low	69	92	111	132	155	174	197	214	243	166	186	232	268	289	339	365	389	429	454	479
	Med-High	78	107	128	149	172	203	230	249	278	204	225	282	312	353	383	406	452	489	519	552
	High	124	157	186	220	261	291	321	352	386	326	372	427	464	526	566	608	658	706	762	808

BLOWER DATA

SL280UH135V60D BLOWER PERFORMANCE (less filter)

BOTTOM RETURN AIR, RETURN AIR FROM BOTH SIDES OR RETURN AIR FROM BOTTOM AND ONE SIDE

0 through 0.8 in. w.g. (Heating) and 0 through 1.0 in. w.g. (Cooling) External Static Pressure Range

HEATING

¹ Heating Speed DIP Switch Settings	First Stage Heating Speed - cfm	Second Stage Heating Speed - cfm
+24%	1875	2065
+18%	1785	1965
+12%	1695	1865
+6%	1605	1765
Factory Default	1515	1665
-6%	1425	1565
-12%	1330	1465
-18%	1240	1365

COOLING

¹ Cooling Speed DIP Switch Settings	First Stage Cooling Speed - cfm				Second Stage Cooling Speed - cfm			
	Low	Medium-Low	Medium-High	² High	Low	Medium-Low	Medium-High	² High
+	1025	1120	1325	1650	1500	1600	1840	2235
Factory Default	965	1015	1180	1490	1420	1510	1700	2110
-	875	930	1060	1350	1225	1320	1505	1840

¹ Cooling and heating speeds are based on a combination of DIP switch settings on the furnace control. Refer to Installation Instructions for specific DIP Switch Settings.

² Factory default setting.

NOTES - The effect of static pressure is included in air volumes shown.

First stage HEAT is approximately 91% of the same second stage HEAT.

First stage COOL (two-stage air conditioning units only) is approximately 70% of the same second stage COOL speed position.

Continuous Fan Only speed is selectable at 28% and 38% of the selected second stage cooling speed - minimum 450 cfm.

Lennox iHarmony® Zoning System Applications - Minimum blower speed is 450 cfm.

SL280UH135V60D BLOWER MOTOR WATTS (COOLING)

¹ Cooling Speed DIP Switch Settings	Motor Watts @ Various External Static Pressures - in. wg.																			
	First Stage										Second Stage									
	0	0.1	0.2	0.3	0.4	0.5	0.6	0.7	0.8	0	0.1	0.2	0.3	0.4	0.5	0.6	0.7	0.8	0.9	1.0

+ Setting

Cooling Speed	Low	72	99	123	145	177	204	228	253	277	180	208	244	299	334	374	408	432	478	511	539
	Med-Low	80	108	137	164	194	224	252	280	308	214	249	291	340	384	422	450	493	530	579	619
	Med-High	119	154	180	227	259	298	328	363	392	309	359	404	464	509	560	622	661	715	757	809
	High	239	271	320	370	394	439	477	513	559	655	683	774	832	888	957	1022	1053	1122	1161	1206

Factory Default

Cooling Speed	Low	52	79	95	120	147	167	188	215	238	127	161	197	238	277	316	349	386	412	457	493
	Med-Low	63	87	116	137	158	188	210	239	262	160	194	229	280	317	350	395	431	451	502	540
	Med-High	86	115	152	174	203	236	270	298	328	227	266	333	369	373	405	445	541	579	601	642
	High	160	194	229	278	318	359	394	429	455	468	521	580	647	716	763	819	872	934	994	1053

- Setting

Cooling Speed	Low	45	65	87	107	128	152	170	191	210	103	133	167	199	235	268	294	325	366	391	425
	Med-Low	50	70	95	120	140	166	185	208	228	109	143	178	213	247	283	320	359	380	421	455
	Med-High	71	97	123	147	175	204	228	254	279	171	203	235	294	328	370	401	439	478	515	543
	High	127	160	196	232	265	299	334	369	403	294	343	402	457	510	576	619	673	720	781	835

BLOWER DATA

SL280UH135V60D BLOWER PERFORMANCE (less filter)

SINGLE SIDE RETURN AIR – Air volumes in bold require Optional Return Air Base and field fabricated transition to accommodate 20 x 25 x 1 in. air filter in order to maintain proper air velocity.

0 through 0.8 in. w.g. (Heating) and 0 through 1.0 in. w.g. (Cooling) External Static Pressure Range

HEATING

¹ Heating Speed DIP Switch Settings	First Stage Heating Speed - cfm	Second Stage Heating Speed - cfm
+24%	1850	2035
+18%	1760	1935
+12%	1670	1835
+6%	1580	1740
Factory Default	1490	1640
-6%	1400	1540
-12%	1310	1445
-18%	1225	1345

COOLING

¹ Cooling Speed DIP Switch Settings	First Stage Cooling Speed - cfm				Second Stage Cooling Speed - cfm			
	Low	Medium-Low	Medium-High	² High	Low	Medium-Low	Medium-High	² High
+	1030	1105	1305	1635	1525	1600	1840	2255
Factory Default	960	1005	1175	1480	1355	1435	1635	2035
-	845	925	1050	1340	1240	1315	1520	1850

¹ Cooling and heating speeds are based on a combination of DIP switch settings on the furnace control. Refer to Installation Instructions for specific DIP Switch Settings.

² Factory default setting.

NOTES - The effect of static pressure is included in air volumes shown.

First stage HEAT is approximately 91% of the same second stage HEAT.

First stage COOL (two-stage air conditioning units only) is approximately 70% of the same second stage COOL speed position.

Continuous Fan Only speed is selectable at 28% and 38% of the selected second stage cooling speed - minimum 450 cfm.

Lennox iHarmony® Zoning System Applications - Minimum blower speed is 450 cfm.

SL280UH135V60D BLOWER MOTOR WATTS (COOLING)

¹ Cooling Speed DIP Switch Settings	Motor Watts @ Various External Static Pressures - in. wg.																				
	First Stage										Second Stage										
	0	0.1	0.2	0.3	0.4	0.5	0.6	0.7	0.8	0	0.1	0.2	0.3	0.4	0.5	0.6	0.7	0.8	0.9	1.0	
+ Setting																					
Cooling Speed	Low	66	97	120	138	165	195	220	245	279	189	220	259	298	333	378	410	441	486	517	543
	Med-Low	82	111	140	161	190	218	255	269	306	224	255	298	354	389	422	455	499	549	571	616
	Med-High	114	148	177	218	254	288	320	359	381	317	359	418	459	511	557	615	655	701	747	795
	High	233	268	307	357	396	430	475	503	544	668	704	766	831	898	941	995	1048	1103	1144	1176
Factory Default																					
Cooling Speed	Low	49	76	97	121	146	170	198	223	246	130	166	200	238	281	318	350	398	425	462	490
	Med-Low	58	89	109	130	161	193	221	238	267	163	185	240	290	318	347	398	432	460	500	538
	Med-High	76	109	135	170	200	231	268	290	324	233	281	333	368	408	456	499	539	591	644	693
	High	162	195	230	282	318	356	391	425	457	484	529	603	651	721	783	832	898	951	994	1051
- Setting																					
Cooling Speed	Low	41	60	86	104	129	149	169	190	212	94	130	161	189	221	259	288	317	355	390	421
	Med-Low	50	72	96	120	139	160	184	201	235	114	147	177	211	256	290	330	354	385	422	453
	Med-High	73	101	123	147	167	196	221	250	274	177	207	245	291	331	370	413	431	475	509	543
	High	118	151	181	231	261	303	327	363	399	328	369	431	477	535	580	638	683	723	777	827

REVISIONS

Sections	Description of Change
Approvals and Warranty	Updated "California Only" section for Low NOx.
Dimensions - Furnace/Coil Combined Dimensions	Updated to show latest models
High Altitude Derate	Manifold Pressure updated for Low Fire with LPG/Propane.



Visit us at www.lennox.com

For the latest technical information, www.LennoxPros.com

Contact us at 1-800-4-LENNOX

NOTE - Due to Lennox' ongoing commitment to quality, Specifications, Ratings and Dimensions subject to change without notice and without incurring liability. Improper installation, adjustment, alteration, service or maintenance can cause property damage or personal injury. Installation and service must be performed by a qualified installer and servicing agency.

©2020 Lennox Industries, Inc.