



XC16

ELITE® Series

R-410A - Two-Stage Compressor - 60 Hz

**RESIDENTIAL
PRODUCT SPECIFICATIONS**

Bulletin No. 210841
November 2019
Supersedes March 2019



**ELITE®
SERIES**



**SEER up to 17.00
2 to 5 Tons**

Cooling Capacity - 22,800 to 58,500 Btuh

MODEL NUMBER IDENTIFICATION

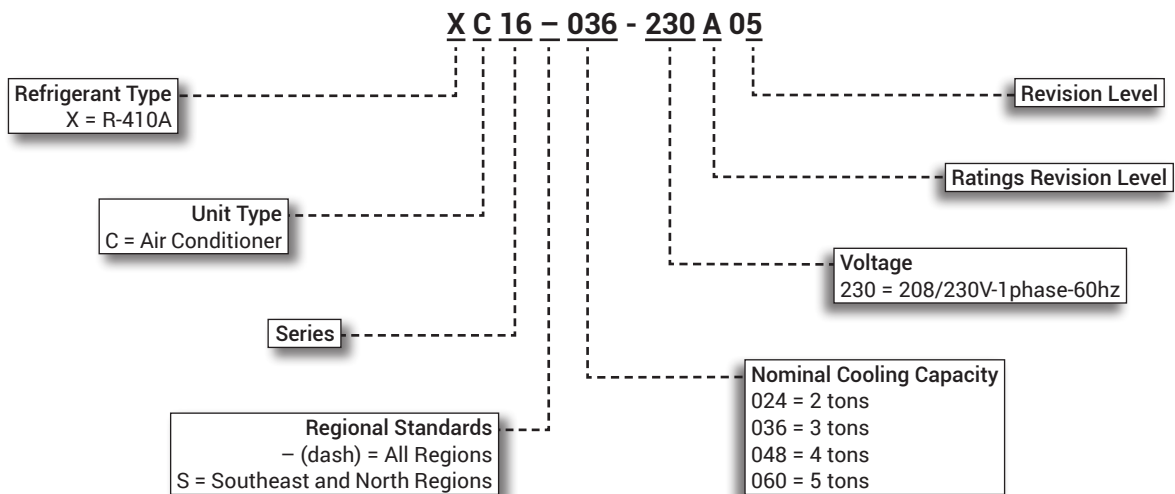

FEATURE HIGHLIGHTS

1. Outdoor Coil Fan
2. Copper Tube/Enhanced Fin Coil
3. High Pressure Switch
4. Low Pressure Switch
5. High Capacity Liquid Line Drier
6. Two-Stage Scroll Compressor
7. Heavy Gauge Steel Cabinet
8. SmartHinge™ Louvered Coil Protection
9. Refrigerant Line Connections and Access

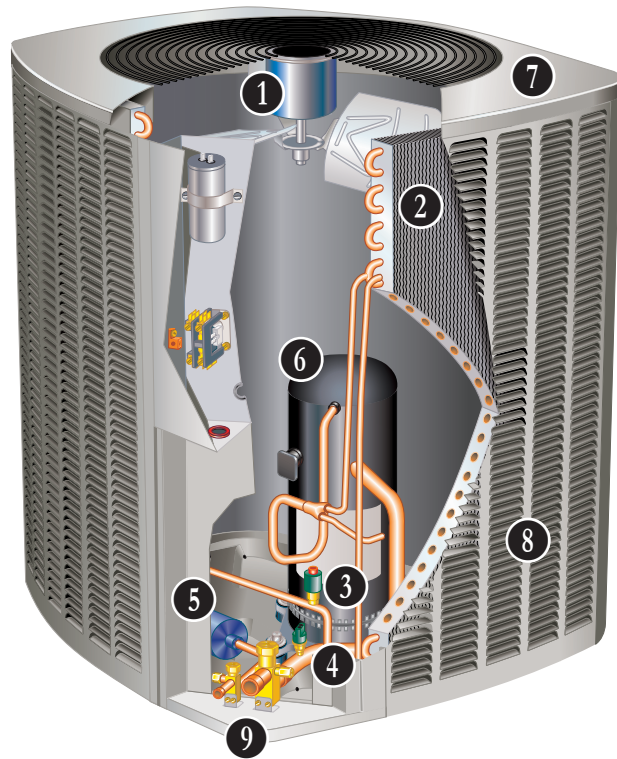

CONTENTS

Approvals and Warranty	3
Dimensions - Unit	9
Electrical Data	7
Features	3
Field Wiring	8
Installation Clearances	8
Optional Accessories - Order Separately	7
Sound Data	8
Specifications	7
TXV Usage	10

APPROVALS AND WARRANTY

APPROVALS

- AHRI Standard 210/240 certified
- AHRI Certified system match-ups and expanded ratings, visit www.LennoxPros.com
- ENERGY STAR® Certified (certain units)
- Sound rated to AHRI Standard 270-2008 test conditions
- Tested in Lennox' Research Laboratory environmental test room
- Rated According to U.S. Department of Energy (DOE) test procedures
- Region specific models meet the minimum efficiency requirements for U.S DOE Federal Regional Standards in that area
- Unit and components ETL, NEC and CEC bonded for grounding to meet safety standards for servicing
- ETL certified (U.S. and Canada)
- ISO 9001 Registered Manufacturing Quality System

WARRANTY

- Compressor:
 - Limited ten years in residential installations
 - Limited five years in non-residential installations
- **All other covered components:**
 - Limited five years in residential installations
 - Limited one year in non-residential installations

NOTE - Refer to Lennox Equipment Limited Warranty certificate included with unit for specific details.

FEATURES

APPLICATIONS

- 2 through 5 ton
- Sound levels as low as 73 dBA
- Single phase power supply
- Applicable to indoor air handlers or gas furnaces with indoor add-on coils
- Shipped completely factory assembled, piped and wired

REFRIGERATION SYSTEM

R-410A Refrigerant

- Non-chlorine, ozone friendly
- Unit is factory pre-charged

1 Outdoor Coil Fan

- Direct drive fan
- Vertical air discharge
- Sleeve bearings
- Inherently protected
- Totally enclosed fan motor
- PVC (polyvinyl chloride) coated steel fan guard

2 Copper Tube/Enhanced Fin Coil

- Lennox designed and fabricated coil
- Ripple-edged aluminum fins
- Copper tube construction
- Lanced fins for maximum fin surface exposure
- Fin collars grip tubing for maximum contact area
- Flared shoulder tubing connections
- Silver soldering construction
- Factory tested under high pressure
- Entire coil is accessible for cleaning

3 High Pressure Switch

- Protects the system from high pressure conditions
- Automatic reset

4 Low Pressure Switch

- Shuts off unit if suction pressure falls below setting
- Provides loss of charge and freeze-up protection
- Auto-reset

5 Hi-Capacity Liquid Line Drier

- Factory installed in the liquid line, the drier traps moisture or dirt that could contaminate the refrigerant system
- 100% molecular-sieve bead type drier

FEATURES

REFRIGERATION SYSTEM (continued)

Optional Accessories

Expansion Valve Kits

- Field installed on certain indoor units
- See TXV Usage table
- Chatleff style fitting

Freezestat

- Senses suction line temperature
- Cycles compressor off when suction line temperature falls below it's setpoint
- Opens at 29°F and closes at 58°F
- Installs on or near the discharge line of the evaporator or on the suction line

Refrigerant Line Kits

- Refrigerant lines are shipped refrigeration clean
- Lines are cleaned, dried, pressurized and sealed at factory
- Suction line fully insulated
- Lines are stubbed at both ends

NOTE - Not available for -060 models. Must be field fabricated.

COMPRESSOR

6 Two-Stage Scroll Compressor

- High volumetric efficiency
- Uniform suction flow
- Constant discharge flow
- Quiet operation

Compressor Operation

- Two involute spiral scrolls matched together generate a series of crescent shaped gas pockets between them
- During compression, one scroll remains stationary while the other scroll orbits around it
- Gas is drawn into the outer pocket, the pocket is sealed as the scroll rotates
- As the spiral movement continues, gas pockets are pushed to the center of the scrolls
- Volume between the pockets is simultaneously reduced
- When the pocket reaches the center, gas is now at high pressure and is forced out of a port located in the center of the fixed scrolls
- During compression, several pockets are compressed simultaneously resulting in a smooth continuous compression cycle
- Continuous flank contact, maintained by centrifugal force, minimizes gas leakage and maximizes efficiency
- Compressor is tolerant to the effects of slugging and contaminants

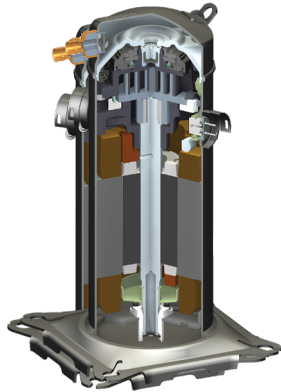

- If this occurs, scrolls separate, allowing liquid or contaminants to be worked toward the center and discharged
- During the compression process, there are several pockets in the scroll that are compressing gas
- Modulation is achieved by venting a portion of the gas in the first suction pocket back to the low side of the compressor thereby reducing the effective displacement of the compressor
- A 24-volt DC solenoid valve inside the compressor controls staging
- When the 3-way solenoid is energized it moves the lift ring assembly to block the ports and the compressor operates at full-load or 100% capacity
- When the solenoid is de-energized the lift ring assembly moves to unblock the compressor ports and the compressor operates at part-load or approximately 67% of its full-load capacity
- The "loading" and "unloading" of the two stage scroll is done "on the fly" without shutting off the single-speed compressor motor between stages
- Low gas pulses during compression reduces operational sound levels
- Compressor motor is internally protected from excessive current and temperature
- Compressor is installed in the unit on specially formulated, resilient rubber mounts for better sound dampening and vibration free operation

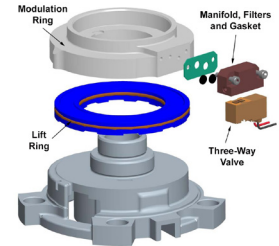

Crankcase Heater (048-060 models only)

- Prevents liquid refrigerant migration into compressor and ensures proper compressor lubrication

Optional Accessories

Crankcase Heater (Optional for 024-036 models)

- Prevents liquid refrigerant migration into compressor and ensures proper compressor lubrication

Compressor Hard Start Kit

- A PSC compressor motor does not normally need a potential relay and start capacitor
- In cases of low voltage, kit may be required to increase the compressor starting torque

NOTE - Compressor Hard start Kit is required in applications where the supply voltage is less than 230V.

Compressor Sound Cover

- Reinforced vinyl compressor cover
- Contains 1-1/2 inch thick batt of fiberglass insulation
- All open edges are sealed with a one-inch wide hook and loop fastening tape

FEATURES

CONTROLS

Optional Accessories

iComfort® E30 Smart Wi-Fi Thermostat

- Wi-Fi enabled, electronic 7-day, universal, multi-stage, programmable, touchscreen thermostat
- 3 Heat/2 Cool
- Auto-changeover
- Controls dehumidification during cooling mode and humidification during heating mode
- Offers enhanced capabilities including humidification / dehumidification / dewpoint measurement and control, Humiditrol® control, and equipment maintenance reminders
- Easy to read 7 in. color touchscreen (measured diagonally)
- LCD display with backlight shows the current and set temperature, time, inside relative humidity, system status (operating mode and schedules) and outside temperature (optional outdoor sensor required)
- Smooth Setback Recovery starts system early to achieve setpoint at start of program period
- Compressor short-cycle protection (5 minutes)
- Up to four separate schedules are available plus Schedule IQ™
- One-Touch Away Mode - A quick and easy way to set the cooling and heating setpoints while away
- Smart Away™ - Uses geo-fencing technology to determine when the homeowner is within a predetermined distance from the home to operate the system when leaving, away and arriving
- Wi-Fi remote monitoring and adjustment through a home wireless network for desktop PCs, laptops and apps for smartphones or tablets
- Smart home automation compatible with Apple HomeKit™, Amazon Alexa®, Google Assistant and IFTTT
- High Definition Color Display, Mag-Mount, Smart Hub Controller, wallplate (for retrofit installations) furnished for easy installation
- See the iComfort® E30 Smart Wi-Fi Thermostat Product Specifications bulletin for more information



Remote Outdoor Temperature Sensor

- Used with the iComfort® E30 Smart Wi-Fi Thermostat
- When installed outdoors, sensor allows thermostat to display outdoor temperature
- Sensor is auto-detected when connected to thermostat

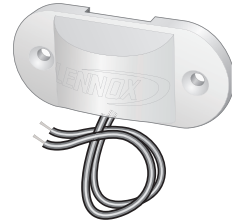

NOTE - Sensor is required for the Enhanced Dehumidification Accessory (EDA).

Thermostat

- Thermostat is not furnished with unit
- See Lennox Price Book for selection

Blower Relay Kit (for use with furnaces equipped with constant torque blower motors)

- Allows furnace blower speed changes when matched with two-stage air conditioners

Indoor Blower Off Delay Relay

- Delays the indoor blower-off time during the cooling cycle

Indoor Blower Speed Relay

- Relay kit provides the option of changing blower speeds on standard permanent split capacitor (PSC) multi-tap blower motors during cooling operation
- Provides optimum humidity control conditions by automatically reducing indoor blower speed during continuous fan operation or low stage compressor operation to reduce humidity levels

Low Ambient Kit

- Air conditioners can operate down to 45°F outdoor air temperature without additional controls
- Allows unit to operate properly down to 30°F

NOTE - Crankcase heater and freestat should be installed on compressors equipped with a low ambient kit.

NOTE - A Compressor Low Ambient Cut-Off Switch should be added to terminate compressor operation below recommended operation conditions.

FEATURES

CABINET

- 7 • Heavy-gauge steel construction
- Pre-painted cabinet finish
- Louvered heavy gauge steel panels surround unit on all four sides
- Control box is conveniently located with all controls factory wired
- Corner patch plate allows access to compressor components
- Drainage holes are provided in base section for moisture removal
- High density polyethylene unit support feet raise the unit off of the mounting surface, away from damaging moisture

PermaGuard™ Unit Base

- Durable zinc-coated base section resists rust and corrosion

8 SmartHinge™ Louvered Coil Protection

- Steel louvered panels provides complete coil protection
- Panels are hinged to allow easy cleaning and servicing of coils
- Panels may be completely removed
- Interlocking tabs and slots assure tight fit on cabinet



9 Refrigerant Line Connections, Electrical Inlets and Service Valves

- Sweat connection suction and liquid lines
- Located on corner of unit cabinet
- Suction valve can be fully shut off, while liquid valve may be front seated to manage refrigerant charge while servicing system
- Refrigerant line connections and field wiring inlets are located in one central area of the cabinet
- See dimension drawing

SPECIFICATIONS

General Data	Model No.	All Regions Southeast and North Regions	XC16-024	XC16-036	XC16-048	XC16-060
			XC16S024	XC16S036	XC16S048	XC16S060
		Nominal Tonnage	2	3	4	5
Connections (sweat)		Liquid line (o.d.) - in.	3/8	3/8	3/8	3/8
		Suction line (o.d.) - in.	3/4	7/8	7/8	1-1/8
Refrigerant		¹ R-410A charge furnished	7 lbs. 2 oz.	9 lbs. 0 oz.	10 lbs. 6 oz.	13 lbs. 2 oz.
Outdoor Coil	Net face area - sq. ft.	Outer coil	24.50	16.33	21.00	29.09
		Inner coil	- - -	15.76	20.27	28.24
		Tube diameter - in.	5/16	5/16	5/16	5/16
		No. of rows	1	2	2	2
		Fins per inch	26	22	22	22
Outdoor Fan		Diameter - in.	22	22	22	26
		No. of blades	4	4	4	3
		Motor hp	1/6	1/4	1/3	1/3
		Cfm	3260	3500	3700	4325
		Rpm	840	825	820	865
		Watts	220	300	300	240
	Shipping Data - lbs. 1 pkg.			249	243	268

ELECTRICAL DATA

Line voltage data - 60hz		⁴ 230V-1ph	⁴ 230V-1ph	⁴ 230V-1ph	⁴ 230V-1ph
² Maximum overcurrent protection (amps)		20	30	40	50
³ Minimum circuit ampacity		15.6	20.8	29.2	35.7
Compressor	Rated load amps	10.19	14.15	17.05	23.5
	Locked rotor amps	55.2	78.1	109	118
	Power factor	0.98	0.95	0.97	0.95
Outdoor Fan Motor	Full load amps	1.0	1.7	1.8	1.8
	Locked Rotor amps	1.9	3.1	2.9	2.9

CONTROLS

iComfort® E30 Smart Wi-Fi Thermostat	15S63	•	•	•	•
Remote Outdoor Temperature Sensor	X2658	•	•	•	•
⁶ Discharge Air Temperature Sensor	88K38	•	•	•	•

OPTIONAL ACCESSORIES - ORDER SEPARATELY

Blower Relay Kit (for constant torque gas furnaces)	85W66	•	•	•	•
Compressor Crankcase Heater	93M04	•	•		
	Factory			•	•
Compressor Sound Cover	27W55	•	•		
	27W56			•	•
Compressor Hard Start Kit - Required in applications with less than 230V	63W22	•			
	10J42		•	•	
	63W24				•
Compressor Low Ambient Cut-Off	45F08	•	•	•	•
Compressor Time-Off Control	47J27	•	•	•	•
Freezestat	3/8 in. tubing	93G35	•	•	•
	5/8 in. tubing	50A93	•	•	•
Indoor Blower Off Delay Relay	58M81	•	•	•	•
Indoor Blower Speed Relay Kit	40K58	•	•	•	•
⁵ Low Ambient Kit (Fan Cycling)	34M72	•	•	•	•
Refrigerant Line Sets	L15-41-20	L15-41-40	•		
	L15-41-30	L15-41-50			
	L15-65-30	L15-65-40		•	•
		L15-65-50			
	Field Fabricate				•

NOTE - Extremes of operating range are plus 10% and minus 5% of line voltage.

¹ Refrigerant charge sufficient for 15 ft. length of refrigerant lines. For longer line set requirements see the Installation Instructions for information about line set length and additional refrigerant charge required.

² HACR type breaker or fuse.

³ Refer to National or Canadian Electrical Code manual to determine wire, fuse and disconnect size requirements.

⁴ Hard Start Kit is required in applications where the supply voltage is less than 230V.

⁵ Crankcase Heater (if not furnished) and Freezestat are recommended with Low Ambient Kit.

⁶ Optional for service diagnostics.

SOUND DATA

1 Unit Model	Octave Band Sound Power Levels dB, re 10 ⁻¹² Watts Center Frequency - HZ							1 Sound Rating Number (dBA)	2 Estimated Sound Pressure Level at Distance From Unit (dBA at distance in ft.)				
	125	250	500	1000	2000	4000	8000		3	5	10	15	50
024	55.5	63	68	69	63	62	57	73	66	61	55	52	41
036	55.5	64	69	68	63	59	55.5	74	67	62	56	53	42
048	56	63	69	71.5	67	63	53.5	75	68	63	57	54	43
060	54.5	62	68	68.5	65.5	65	55.5	75	68	63	57	54	43

NOTE - the octave sound power data does not include tonal correction.

¹ Tested according to AHRI Standard 270-2008 test conditions.

² Estimated sound pressure level at distance based on AHRI Standard 275-2010 method for equipment located on the ground, roof, or on side of building wall with no adjacent reflective surface within 9.8 feet. Sound pressure levels will increase based on changes to assumptions. For other applications, refer to AHRI Standard 275.

FIELD WIRING

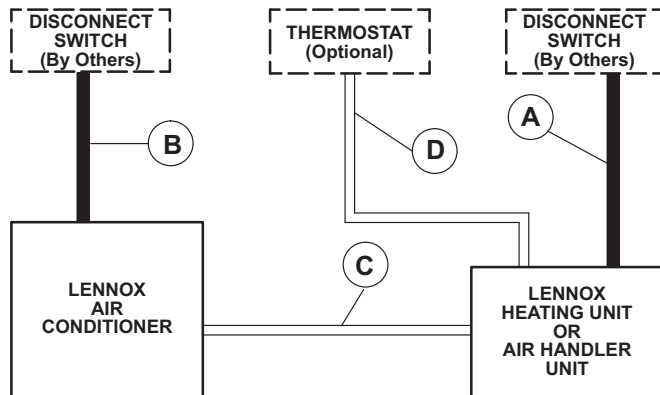

- A - Two Wire Power (not furnished)
 - B - Two Power (not furnished). See Electrical Data
 - C - Four Wire Low Voltage (not furnished). 18 ga. minimum
 - D - Six Wire Low Voltage (not furnished). 18 ga. minimum
- All wiring must conform to NEC or CEC and local electrical codes.*

INSTALLATION CLEARANCES

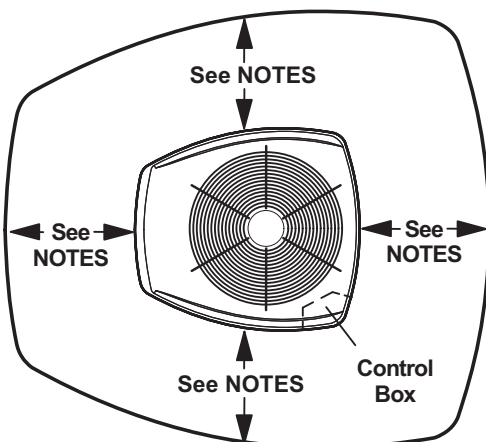

NOTES:

Service clearance of 30 in. (762 mm) must be maintained on one of the sides adjacent to the control box.

Clearance to one of the other three sides must be 36 in. (914 mm)

Clearance to one of the remaining two sides may be 12 in. (305 mm) and the final side may be 6 in. (152 mm).

A clearance of 24 in. (610 mm) must be maintained between two units.

48 in. (1219 mm) clearance required on top of unit.

DIMENSIONS - UNIT

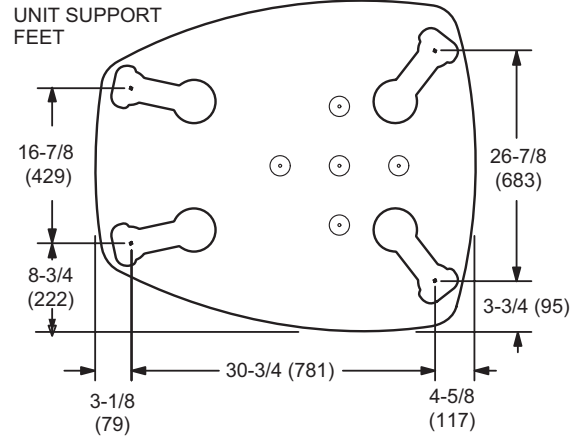
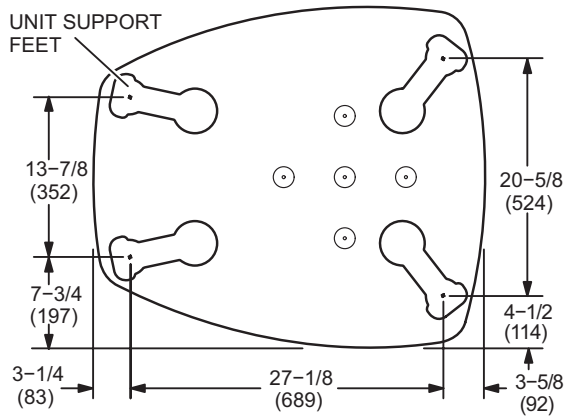
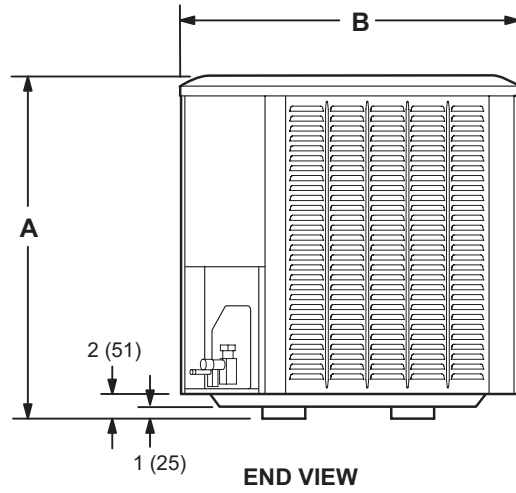
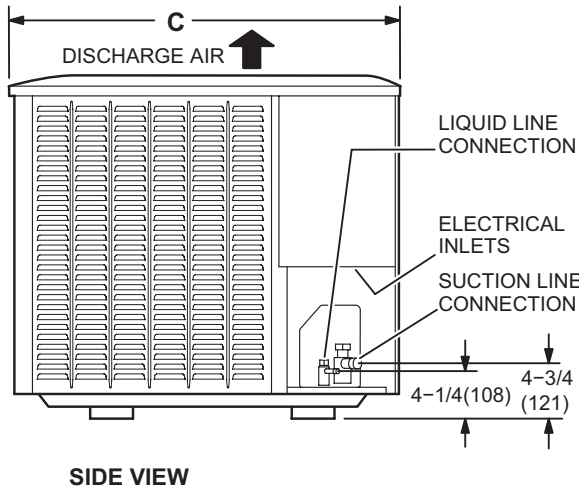
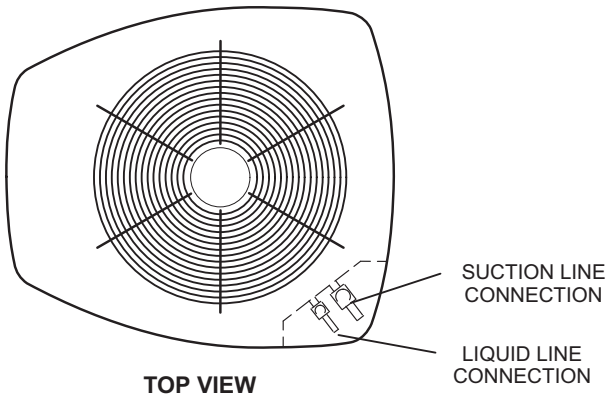

024 TO 048 BASE SECTION (Medium)

060 BASE SECTION (Large)

Model	A		B		C	
	in.	mm	in.	mm	in.	mm
024	45	1143	30-1/2	775	35	889
036	31	787	30-1/2	775	35	889
048	39	991	30-1/2	775	35	889
060	45	1143	35-1/2	902	39-1/2	1003

TXV USAGE

Use this table for C35, CH23, CH33, CH35 and CR33 Field Installed TXV Match-Ups.

Outdoor Unit Model No.	Order No.
XC16(-)(S)024	12J18
XC16(-)(S)036	12J19
XC16(-)(S)048	12J20
XC16(-)(S)060	12J20

CX35, CX38 and CHX35 coils and all Lennox air handlers are shipped with a factory installed TXV. In most cases, no change out of the valve is needed.

If a change out is required it will be listed in the "TXV SUBSTITUTION" table. The correct TXV must be ordered separately and field installed.

C35- Use the orifice shipped with the outdoor unit or replace the factory installed orifice with the expansion valve listed .

CR33 and CH23 coils - Use the orifice shipped with the outdoor unit or use the expansion valve listed.

CH35 coils - Factory installed orifice must be replaced with the expansion valve listed.

MOST POPULAR MATCHES

Outdoor Unit Model No.	Indoor Unit Model No
XC16(-)(S)024	CX38-36B with SL280UH090V36B
XC16(-)(S)036	CX38-43C with SL280UH090V60C
XC16(-)(S)048	CX38-62C with SL280UH090V60C
XC16(-)(S)060	CX38-62C with SL280UH090V60C

TXV SUBSTITUTION

A general guide for replacing the factory installed TXV if the indoor unit (coil/air handler) is larger than the outdoor unit.

Outdoor Unit		Indoor Unit		TXV	TXV
Size	Tons	Size	Tons	Furnished	Replacement
024	2	38	3.5	12J19	12J18
024	2	42	3.5	12J20	12J18
024	2	48	4	12J20	12J18
024	2	49	4	12J20	12J18

TXV Ranges:

12J18 - 1.5 to 2.5 ton systems - Use on 2.5 ton and lower systems.

12J19 - 3 ton systems - Use down to 2 ton systems.

12J20 - 3.5 to 5 ton systems - Use down to 3 ton systems.

AHRI STANDARD 210/240

Cooling or heating capacities are net values, including the effects of blower motor heat, and do not include supplementary heat. Power input is the total power input to the compressor(s) and fan(s), plus any controls and other items required as part of the system for normal operation.

Units which do not have an indoor air-circulating blower furnished as part of the model, i.e., split system with indoor coil only, is established by subtracting from the total cooling capacity 1250 Btu/h per 1,000 cfm, and by adding the same amount to the heating capacity. Total power input for both heating and cooling is increased by 365 W per 1,000 cfm of indoor air circulated.

REVISIONS

Sections	Description of Change
Optional Accessories	Revised Low Ambient kit usage for 048 models.



Visit us at www.lennox.com

For the latest technical information, www.LennoxPros.com

Contact us at 1-800-4-LENNOX

NOTE - Due to Lennox' ongoing commitment to quality, Specifications, Ratings and Dimensions subject to change without notice and without incurring liability. Improper installation, adjustment, alteration, service or maintenance can cause property damage or personal injury. Installation and service must be performed by a qualified installer and servicing agency.

©2019 Lennox Industries, Inc.