



XP20

ELITE® Series

Variable Capacity - R-410A - 60 Hz

**RESIDENTIAL
PRODUCT SPECIFICATIONS**

Bulletin No. 210852
May 2020
Supersedes April 2020

**ELITE®
SERIES**



iComfort®

So simple. So smart. So comfortable.



* iComfort® S30
Ultra-Smart
Wi-Fi Communicating
Thermostat
(not furnished)



**SEER up to 20.00
HSPF up to 10.00
2 to 5 Tons**

**Cooling Capacity - 21,600 to 58,000 Btuh
Heating Capacity - 21,400 to 55,000 Btuh**

MODEL NUMBER IDENTIFICATION

X P 20 - 036 - 230 A 05

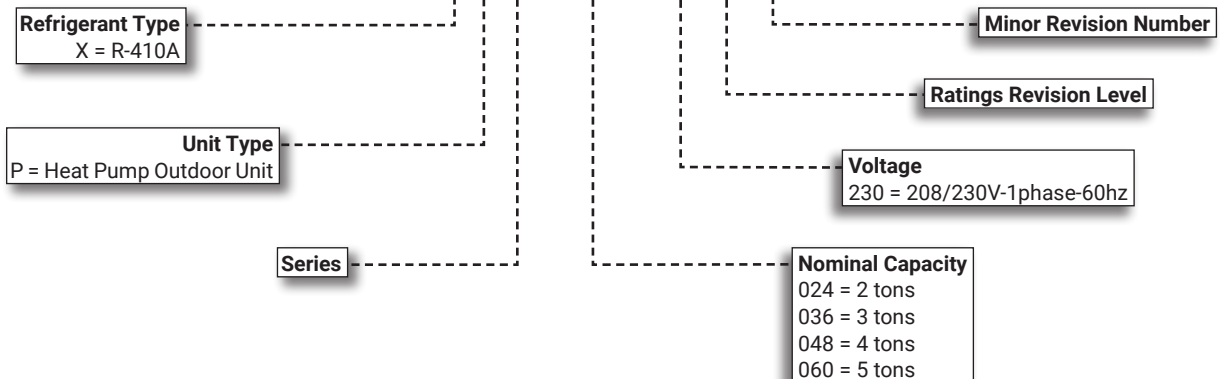

* iComfort® Communicating Thermostat required. Not furnished - Order separately.

FEATURE HIGHLIGHTS

1. Outdoor Coil Fan
2. Variable-Speed Outdoor Coil Fan Motor With Integrated Control
3. Copper Tube/Enhanced Fin Coil
4. Expansion Valve - Outdoor Unit
5. High Pressure Switch
6. Low Pressure Switch
7. Hi-Capacity Liquid Line Drier
8. Reversing Valve
9. Variable Capacity Scroll Compressor
10. DC Inverter Control
11. iComfort® Communicating Control
12. Heavy Gauge Steel Cabinet
13. SmartHinge™ Louvered Coil Protection
14. Refrigerant Line Connections

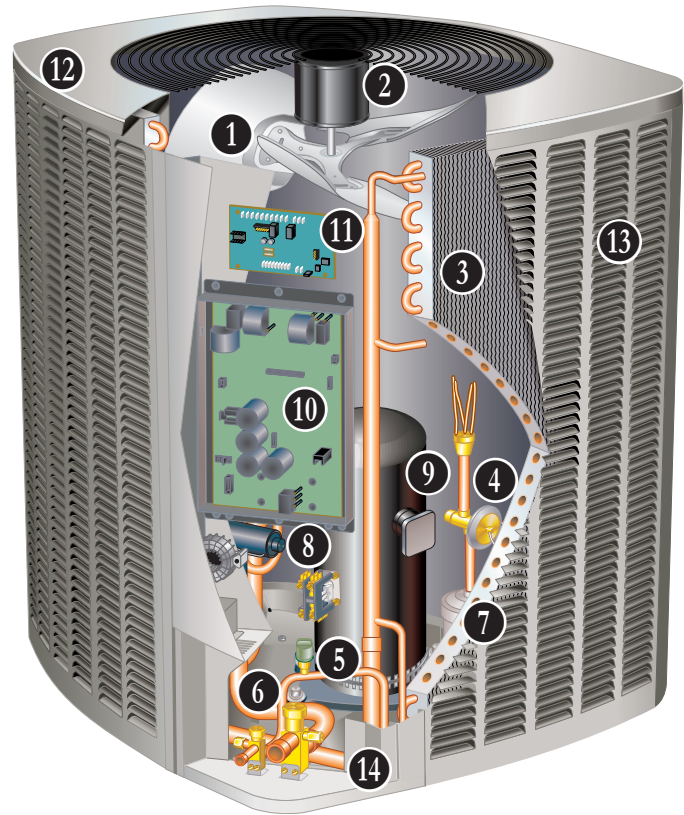

CONTENTS

Approvals And Warranty	3
Dimensions - Unit	9
Electrical Data	8
Features	3
Field Wiring	10
Installation Clearances	10
Optional Accessories - Order Separately	8
Sound Data	10
Specifications	8
TXV Usage.	11

APPROVALS AND WARRANTY

APPROVALS

- AHRI Standard 210/240 certified
- AHRI Certified system match-ups and expanded ratings, visit www.LennoxPros.com
- ENERGY STAR® Certified (certain units)
- Sound rated to AHRI Standard 270-2008 test conditions
- Tested in Lennox' Research Laboratory environmental test room
- Rated According to U.S. Department of Energy (DOE) test procedures
- Unit and components ETL, NEC and CEC bonded for grounding to meet safety standards for servicing
- ETL certified (U.S. and Canada)
- ISO 9001 Registered Manufacturing Quality System

WARRANTY

- Compressor:
 - Limited ten years in residential installations
 - Limited five years in non-residential installations
- All other covered components:
 - Limited five years in residential installations
 - Limited one year in non-residential installations

NOTE - Refer to Lennox Equipment Limited Warranty certificate included with unit for specific details.

FEATURES

APPLICATIONS

- 2 through 5 tons
- Sound levels - low as 65 dB
- Single phase power supply
- Applicable to indoor air handlers or gas furnaces with indoor add-on coils
- Shipped completely factory assembled, piped and wired
- Factory test operated

NOTE - When heat pumps are used with gas furnaces, a dual-fuel compatible thermostat or zone control system with dual-fuel capabilities must be used (order separately).

NOTE - Installer must set outdoor unit, connect refrigerant lines and make electrical connections to complete job.

NOTE - The XP20 heat pump can only be matched with iComfort® Communicating variable-speed indoor furnaces and air handlers.

REFRIGERATION SYSTEM

R-410A Refrigerant

- Non-chlorine, ozone friendly
- Unit is factory pre-charged

NOTE - Total system refrigerant charge is dependant on outdoor unit size, indoor unit size and refrigerant line length.

NOTE - Refer to the unit-mounted charging sticker to determine correct amount of charge required.

1 Outdoor Coil Fan

- Direct drive fan
- Vertical air discharge
- Ball bearings
- PVC (polyvinyl chloride) coated steel fan guard

2 Variable-Speed Outdoor Coil Fan Motor With Integrated Control

- Outdoor coil fan motor with integrated control is programmed for variable capacity operation
- Fan speed is directly controlled by communications between the outdoor unit iComfort® Communicating control and the iComfort® Communicating Thermostat
- Inherently protected
- Totally enclosed fan motor

3 Copper Tube/Enhanced Fin Coil

- Lennox designed and fabricated coil
- Ripple-edged aluminum fins
- Copper tube construction
- Lanced fins for maximum fin surface exposure
- Fin collars grip tubing for maximum contact area
- Inverted coil circuiting prevents ice buildup at coil base in low ambients
- Fin spacing for rapid and complete water drainage
- Flared shoulder tubing connections
- Silver soldering construction
- Factory tested under high pressure
- Entire coil is accessible for cleaning

FEATURES

REFRIGERATION SYSTEM (continued)

4 Expansion Valve - Outdoor Unit

- Designed and sized specifically for use in heat pump system
- Sensing bulb is located on the line between reversing valve and the coil
- Senses suction temperature during the heating cycle
- Factory installed and piped

Discharge Temperature Switch

- Shuts off unit if operating conditions cause the compressor discharge line temperature to rise above setpoint
- Protects compressor from excessive pressure / temperature
- Automatic reset when temperature drops below setpoint

5 High Pressure Switch

- Protects the system from high pressure conditions
- Automatic reset

6 Low Pressure Switch

- Shuts off unit if suction pressure falls below setting
- Provides loss of charge and freeze-up protection
- Auto-reset

7 Hi-Capacity Liquid Line Drier

- Factory installed in the liquid line
- Drier traps moisture or dirt
- 100% molecular-sieve, bead type, bi-flow drier

8 Four-Way Reversing Valve

- Rapid changeover of refrigerant flow direction from cooling to heating and vice versa
- Operates on pressure differential between outdoor unit and indoor coil
- Factory installed

Charge Compensator (036 model only)

- Maintains the proper amount of refrigerant circulating in the system during heating mode

Optional Accessories

Expansion Valve Kits

- Field installed on certain indoor units
- See TXV/Orifice Usage table
- Chatleff-style fitting

Freezestat

- Senses suction line temperature
- Cycles compressor off when suction line temperature falls below it's setpoint
- Opens at 29°F and closes at 58°F
- Installs on or near the discharge line of the evaporator or on the suction line

Refrigerant Line Kits

- Refrigerant lines are shipped refrigeration clean
- Lines are cleaned, dried, pressurized and sealed at factory
- Suction line fully insulated
- Lines are stubbed at both ends

NOTE - Not available for -060 models. Must be field fabricated.

NOTE - The XP20 is a variable capacity heat pump utilizing variable speed compressor technology. With the variable speed compressor and variable pumping capacity, additional consideration must be given to refrigerant piping sizing and application. Please refer to the Installation Instructions or Service Literature for Line Set Requirements and Refrigerant Piping Guidelines.

PRECISE COMFORT® TECHNOLOGY

The Variable Capacity Compressor and DC Inverter Control is an integrated system that operates together to reduce overall energy usage when compared to conventional heat pumps.

9 Variable Capacity Scroll Compressor

- Operates on a variable frequency determined by the DC Inverter Control to vary capacity based on the cooling load required
- Features high efficiency with uniform suction flow, constant discharge flow, high volumetric efficiency and quiet operation



Scroll Compressor Operation

- Two involute spiral scrolls matched together generate a series of crescent-shaped gas pockets between them
- During compression, one scroll remains stationary while the other scroll orbits around it
- Gas is drawn into the outer pocket, the pocket is sealed as the scroll rotates
- As the spiral movement continues, gas pockets are pushed to the center of the scrolls
- Volume between the pockets is simultaneously reduced
- When the pocket reaches the center, gas is now at high pressure and is forced out of a port located in the center of the fixed scrolls
- During compression, several pockets are compressed simultaneously resulting in a smooth continuous compression cycle
- Continuous flank contact, maintained by centrifugal force, minimizes gas leakage and maximizes efficiency
- Compressor is tolerant to the effects of slugging and contaminants
- If this occurs, scrolls separate, allowing liquid or contaminants to be worked toward the center and discharged

FEATURES

PRECISE COMFORT® TECHNOLOGY (continued)

Top Cap Thermal Sensor Switch

- Located on top of the compressor casing
- Discontinues compressor operation in case of abnormal operating conditions

Compressor Crankcase Heater

- Protects against refrigerant migration that can occur during low ambient operation
- Factory Installed

Compressor Sound Dampening System

- Polyethylene compressor
- 2 inch thick batt fiberglass insulation
- All open edges sealed with one-inch wide hook and loop fastening tape

10 DC Inverter Control

- Converts AC line voltage into filtered variable DC voltage
- Provides continuous compressor operation, while adjusting the capacity according to indoor temperature
- Adjusts compressor output in increments as small as 1%
- The accurate sensing of cooling load prevents frequent changes in capacity and ensures efficient, economical operation
- Power Factor Correction (PFC) circuit monitors the DC bus for high, low and abnormal voltage conditions to protect the compressor
- Two LEDs (red and green) indicate inverter operating status and aid in troubleshooting
- Noise filter reduces unwanted electromagnetic interference (EMI). Integrated on the control for 024 and 036 models, external to the control for 048 and 060 models
- The inverter reactor (mounted separately) adds inductance to the line between the inverter and the compressor to limit current rise and protect the compressor



CONTROLS

11 iComfort® Communicating Control

- Advanced control communicates information about various operating parameters in the outdoor unit to the iComfort® Communicating Thermostat to constantly maintain the highest level of comfort, performance and efficiency available
- **Auto Configuration** - On start-up the control automatically sends a description of the outdoor unit to the iComfort® Communicating Thermostat to automatically configure the features available
- Control also features:
 - Seven-Segment Display shows information about outdoor unit type and capacity and also displays alerts for common fault conditions (electrical and mechanical)
 - Low voltage protection prevents compressor operation when voltage is not within the specified range
 - Compressor defrost shift delay - Adjustable 0 (factory) or 30 seconds
 - Demand defrost using outdoor ambient air temperature, coil temperature and compressor run-time inputs - 14 minute maximum defrost time
 - Selectable defrost termination temperature - 50, 70, 90 or 100°F
 - Default setting is 50°F
 - High and low pressure switch monitoring with provisions for lockout
 - Five-Strike lockout protection protects compressor
 - Discharge line temperature and outdoor air temperature monitoring
 - EEPROM storage of all local configurations
 - Non-volatile memory storage of 100 alarm codes with display of last 10 codes for troubleshooting
 - Built-in low ambient control



Low Ambient Operation

- **Cooling Mode** - The heat pump can operate down to 0°F outdoor air temperature in the cooling mode

NOTE - A freezestat is recommended for extra protection during low ambient cooling operation.

- **Heating Mode (Low Temperature Protection)** - Outdoor unit will not operate in the heating mode when the outdoor temperature is at or below -4°F
- If the unit is operating and the outdoor temperature drops below -4°F, the unit will continue to operate until the room thermostat is satisfied or the outdoor temperature drops to -15°F

FEATURES

CONTROLS (continued)

Climate IQ™ Technology

- Optimizes dehumidification settings for specific climates to improve home comfort during cooling or heating operation
- iComfort® S30 Thermostat Setting:
 - **Climate IQ (Auto)** - Dry, Normal, Basic and Humid modes are automatically set based on the difference between the measured relative humidity and the relative humidity setting
- All modes are selected on the iComfort® Communicating Thermostat
- iComfort Wi-Fi® Thermostat Settings:

Cooling Mode

- Three climate settings are available:
 - **Dry** - The system supplies higher indoor airflow at all compressor capacities, increasing efficiency by operating at a higher sensible to total ratio
 - **Moderate** - The system supplies indoor airflow that balances efficiency and comfort
 - **Humid** - The system supplies lower indoor airflow at all compressor capacities, improving humidity removal by operating at a lower sensible to total ratio

Heating Mode

- Two climate settings are available:
 - **Comfort** - The system reduces indoor airflow, increasing supply air temperature
 - **Normal** - Standard system operation

Outdoor Air Temperature Sensor

- Used with iComfort® Communicating Thermostats
- Sensor allows thermostat to display outdoor temperature
- Sensor is auto-detected when connected to thermostat

REQUIRED COMPONENTS

NOTE - The XP20 heat pump can only be used with an iComfort® Communicating Thermostat.

iComfort® S30 Ultra-Smart Wi-Fi Thermostat (part of the iComfort® Residential Communicating Control System)

- Recognizes and connects to all iComfort® Communicating products to automatically configure and control the heating/cooling system (based on user-specified settings) for the highest level of comfort, performance and efficiency
- Recognizes model and serial number information for iComfort® Communicating products to simplify system setup
- Wi-Fi remote temperature monitoring and adjustment through a home wireless network for desktop PCs, laptops and apps for smartphones or tablets
- Service alerts and reminders sent via text message or e-mail
- Smart home automation compatible with Apple HomeKit™, Amazon Alexa®, Google Assistant and IFTTT
- Dealer Dashboard features online real-time monitoring of installed iComfort® Communicating systems
- Simple easy-to-use touchscreen allows complete system configuration
- Scheduled maintenance alerts, system warnings and troubleshooting are also displayed on thermostat screen
- Easy to read 7 inch high definition color display (measured diagonally)
- Conventional outdoor units (not iComfort® Communicating) can easily be added and controlled by the iComfort® S30 Thermostat
- Installer setup screens allow quick and simple system configuration without a manual, Installer can also run tests on complete system or individual components for easy maintenance and troubleshooting
- Serial communications bus (RSBus), with less wiring than a conventional heating/cooling system, allows system communication
- Uses 4-wire, 18-gauge standard thermostat wiring
- High Definition Color Display with Subbase, Smart Hub Controller, wallplate (for retrofit installations) furnished for easy installation
- See the iComfort® S30 Thermostat Product Specifications bulletin for more information



FEATURES

CABINET

- 12 Heavy-gauge steel construction
 - Pre-painted cabinet finish
 - Louvered heavy gauge steel panels surround unit on all four sides
 - Control box is conveniently located with all controls factory wired
 - Corner patch plate allows access to compressor components
 - Drainage holes are provided in base section for moisture removal
 - High density polyethylene unit support feet raise the unit off of the mounting surface, away from damaging moisture

PermaGuard™ Unit Base

- Durable zinc-coated base section resists rust and corrosion

13 **SmartHinge™ Louvered Coil Protection**

- Steel louvered panels provides complete coil protection
- Panels are hinged to allow easy cleaning and servicing of coils
- Panels may be completely removed
- Interlocking tabs and slots assure tight fit on cabinet



14 **Refrigerant Line Connections, Electrical Inlets and Service Valves**

- Sweat connection vapor and liquid lines
- Located on corner of unit cabinet
- Vapor valve can be fully shut off, while liquid valve may be front seated to manage refrigerant charge while servicing system
- Refrigerant line connections and field wiring inlets are located in one central area of the cabinet
- See dimension drawing

Optional Accessories

Snow Guard

- For use in locations where the possibility of heavy snow or freezing rain accumulation may occur
- Heavy gauge powder coated steel guard deflects snow and ice away from the outdoor fan and prevents build-up on the fan guard

SPECIFICATIONS

General Data		Model No.	XP20-024	XP20-036	XP20-048	XP20-060	
		Nominal Tonnage	2	3	4	5	
Connections (sweat)	Liquid line (o.d.) - in.		3/8	3/8	3/8	3/8	
	Vapor line (o.d.) - in.		3/4	7/8	7/8	1-1/8	
Refrigerant		¹ R-410A charge furnished	7 lbs. 9 oz.	12 lbs. 6 oz.	12 lbs. 11 oz.	13 lbs. 15 oz.	
Outdoor Coil	Net face area - sq. ft.		Outer coil	21.00	21	24.5	27.22
			Inner Coil	- - -	20.27	23.64	26.36
			Tube diameter - in.	5/16	5/16	5/16	5/16
			No. of rows	1	2	2	2
			Fins per inch	22	22	22	22
Outdoor Fan	Diameter - in.		26	26	26	26	
	No. of blades		3	3	3	3	
	Motor hp (W)		1/3	1/3	1/3	1/3	
	Cfm - Min. Speed		1500	2012	2900	2400	
	Max. Speed		2520	3678	3850	4160	
	Rpm - Min. Speed		400	405	600	480	
	Max. Speed		700	750	800	835	
	Watts - Min. Speed		30	29	77	47	
		Max .Speed	63	149	178	203	
Shipping Data - lbs. - 1 pkg.			247	280	326	330	

ELECTRICAL DATA

Line voltage data - 60hz	208/230V-1ph	208/230V-1ph	208/230V-1ph	208/230V-1ph		
² Maximum overcurrent protection (amps)	30	35	50	60		
³ Minimum circuit ampacity	19.1	20.8	29.3	34.9		
Compressor	Rated load amps		13.0	14.4	21.2	25.7
	Locked rotor amps		13	13	20	20
	Power factor		.98	.99	.99	.99
Outdoor Coil Fan Motor - Full load amps			2.8	2.8	2.8	2.8

REQUIRED COMPONENTS - ORDER SEPARATELY

iComfort® S30 Ultra-Smart Wi-Fi Thermostat	12U67	•	•	•	•
⁴ Discharge Temperature Sensor	88K38	•	•	•	•

OPTIONAL ACCESSORIES - ORDER SEPARATELY

⁵ Freezestat	3/8 in. tubing	93G35	•	•	•	•
	5/8 in. tubing	50A93	•	•	•	•
⁶ Refrigerant Line Sets	L15-41-20 , L15-41-30, L15-41-40, L15-41-50		•			
	L15-65-30, L15-65-40, L15-65-50			•	•	
	Field Fabricate					•
⁷ Snow Guard	39-1/2 x 35-5/8 in.	Y1033	•	•	•	•

NOTE - Extremes of operating range are plus 10% and minus 5% of line voltage.

¹ Refrigerant charge sufficient for 15 ft. length of refrigerant lines. For longer line set requirements see the Installation Instructions for information about line set length and additional refrigerant charge required.

² HACR type breaker or fuse.

³ Refer to National or Canadian Electrical Code manual to determine wire, fuse and disconnect size requirements.

⁴ Used with the iComfort® Communicating Thermostats for optional service diagnostics.

⁵ Freezestat is recommended for Low Ambient operation.

⁶ Refer to the Installation Instructions or Service Literature for Line Set Requirements and Refrigerant Piping Guidelines.

⁷ Adds 11-1/2 inches (292 mm) to unit height.

DIMENSIONS - UNIT

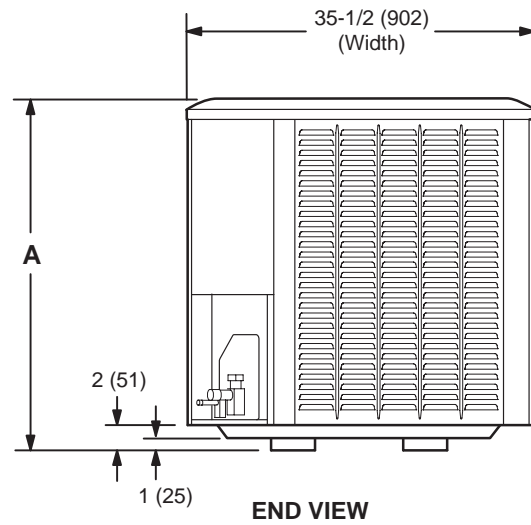
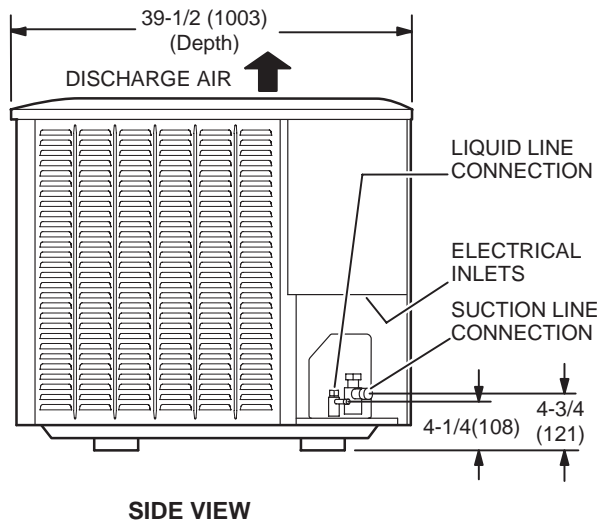
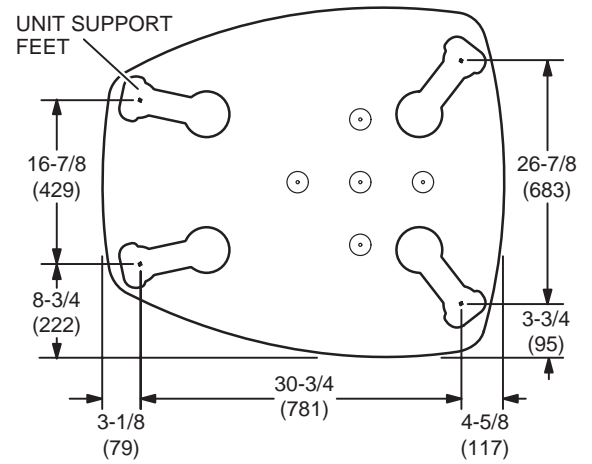
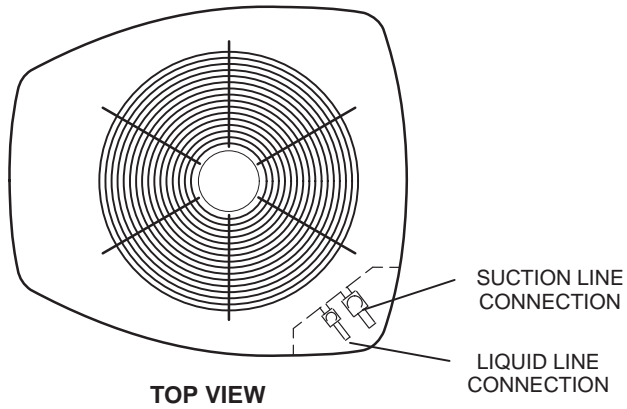

Model No.	A	
	in.	mm
XP20-024	39	991
XP20-036	39	991
XP20-048	45	1143
XP20-060	45	1143

FIELD WIRING

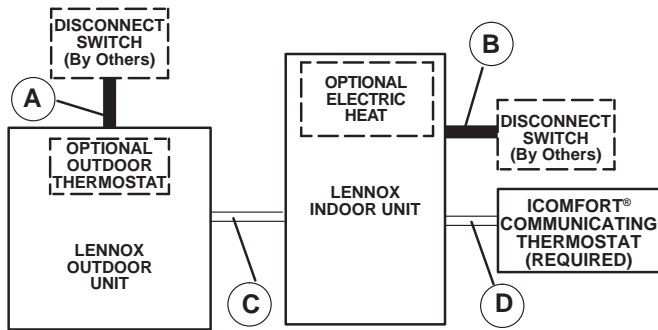

A - Two Wire Power

B - Two or Three Wire Power (size to heater capacity)

C - iComfort® Communicating Thermostat:
- Four Wire, 18AWG (RSBus)

D - iComfort® Communicating Thermostat:

- Two Wire, 18AWG (RSBus) unshielded thermostat cable for power terminals (R, C, 12+ AND 12-)

- Two Wire, 22AWG (RSBus) shielded thermostat cable recommended for communications terminals (I+, I-, A and B)

NOTE - All wiring must conform to NEC or CEC and local electrical codes.

NOTE - Field wiring is not furnished.

SOUND DATA

1 Unit Model	Octave Band Sound Power Levels dBA, re 10 ⁻¹² Watts Center Frequency - HZ							1 Sound Rating Number (dBA)	2 Estimated Sound Pressure Level at Distance From Unit (dB at distance in ft.)				
	125	250	500	1000	2000	4000	8000		3	5	10	15	50
024 Min.	50.7	50.8	48.9	50.6	47	46.9	53.3	65	58	53	47	44	33
024 Max.	51.7	54.5	58.2	60.9	60.2	58	58	72	65	60	54	51	40
036 Min.	50.6	51.1	52	52.3	45.8	43.5	48.7	67	60	55	49	46	35
036 Max.	54.1	59.6	65.5	64.6	60.4	57.9	58.7	75	68	63	57	54	43
048 Min.	52.8	54.7	59.9	57.8	51.9	50.6	58.2	68	61	56	50	47	36
048 Max.	57.7	59.2	65.6	64.6	60.2	59.6	58.4	75	68	63	57	54	43
060 Min.	51.1	53.5	56.8	55.3	49.7	50.4	56.7	69	62	57	51	48	37
060 Max.	53.8	59.8	66.5	65.5	61.7	60.7	59.4	75	68	63	57	54	43

NOTE - The octave sound power data does not include tonal correction.

¹ Tested according to AHRI Standard 270-2008 test conditions.

² Estimated sound pressure level at distance based on AHRI Standard 275-2010 method for equipment located on the ground, roof, or on side of building wall with no adjacent reflective surface within 9.8 feet. Sound pressure levels will increase based on changes to assumptions. For other applications, refer to AHRI Standard 275.

INSTALLATION CLEARANCES

NOTES:

Service clearance of 30 in. (762 mm) must be maintained on one of the sides adjacent to the control box.

Clearance to one of the other three sides must be 36 in. (914 mm)

Clearance to one of the remaining two sides may be 12 in. (305 mm) and the final side may be 6 in. (152 mm).

A clearance of 24 in. must be maintained between two units.

48 in. (1219 mm) clearance required on top of unit.

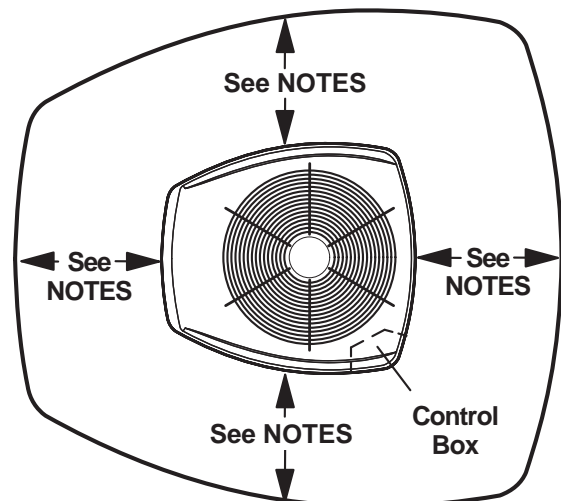

TXV USAGE

Use this table for C35, CH23, CH35 and CR33 Field Installed TXV Match-Ups.

Model No.	Order No.
XP20-024	12J18
XP20-036	12J19
XP20-048	12J20
XP20-060	12J20

CX35 and CHX35 coils and all Lennox air handlers are shipped with a factory installed TXV.

C35 and CH35 coils - Replace the factory installed RFC orifice with the expansion valve listed.

CH23 and CR33 - Use the expansion valve listed.

AHRI STANDARD 210/240

Cooling or heating capacities are net values, including the effects of blower motor heat, and do not include supplementary heat. Power input is the total power input to the compressor(s) and fan(s), plus any controls and other items required as part of the system for normal operation.

Units which do not have an indoor air-circulating blower furnished as part of the model, i.e., split system with indoor coil only, is established by subtracting from the total cooling capacity 1250 Btu/h per 1,000 cfm, and by adding the same amount to the heating capacity. Total power input for both heating and cooling is increased by 365 W per 1,000 cfm of indoor air circulated.

REVISIONS

Sections	Description of Change
Features	Added Charge Compensator for 036 model only.
Specifications	Refrigerant charge updated for 036 model only.



Visit us at www.lennox.com

For the latest technical information, www.LennoxPros.com

Contact us at 1-800-4-LENNOX

NOTE - Due to Lennox' ongoing commitment to quality, Specifications, Ratings and Dimensions subject to change without notice and without incurring liability. Improper installation, adjustment, alteration, service or maintenance can cause property damage or personal injury. Installation and service must be performed by a qualified installer and servicing agency.

©2020 Lennox Industries, Inc.