



**ZCA/ZCB**  
Raider® Rooftop Units  
60 Hz

**COMMERCIAL  
PRODUCT SPECIFICATIONS**

Bulletin No. 210819  
September 2019  
Supersedes April 2019



**RAIDER®**  
Value Without Compromise®



**ASHRAE 90.1  
COMPLIANT**

**7.5 to 12.5 Tons**  
**Net Cooling Capacity - 86,000 to 137,000 Btuh**  
**Optional Electric Heat - 7.5 to 60 kW**

**MODEL NUMBER IDENTIFICATION**

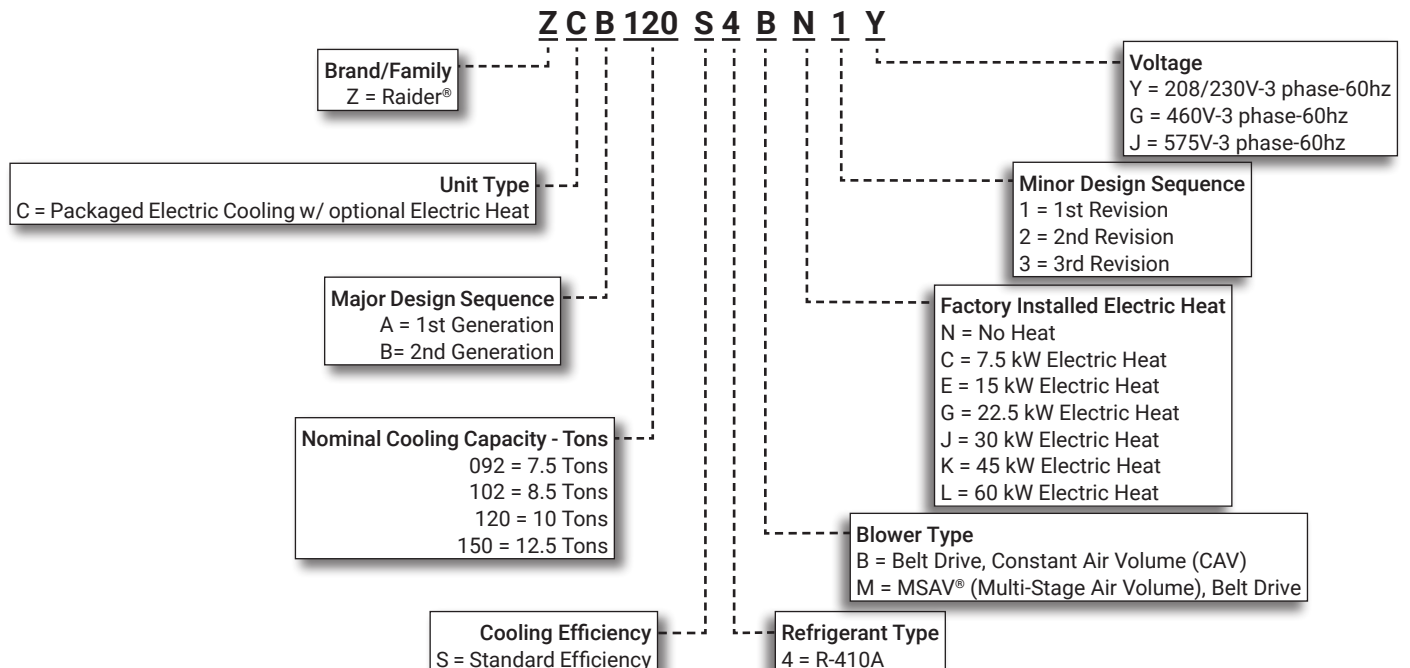

## FEATURE HIGHLIGHTS

Raider® rooftop units from Lennox Commercial are the new standard for cost efficient reliable, efficient rooftop units built for long-lasting performance that can significantly improve indoor environments.

1. Scroll Compressors
2. Lennox' Environ™ Coil System
3. Outdoor Coil Fans
4. Heavy Gauge Steel Cabinet
5. Supply Air Blower
6. Electric Heat (option)

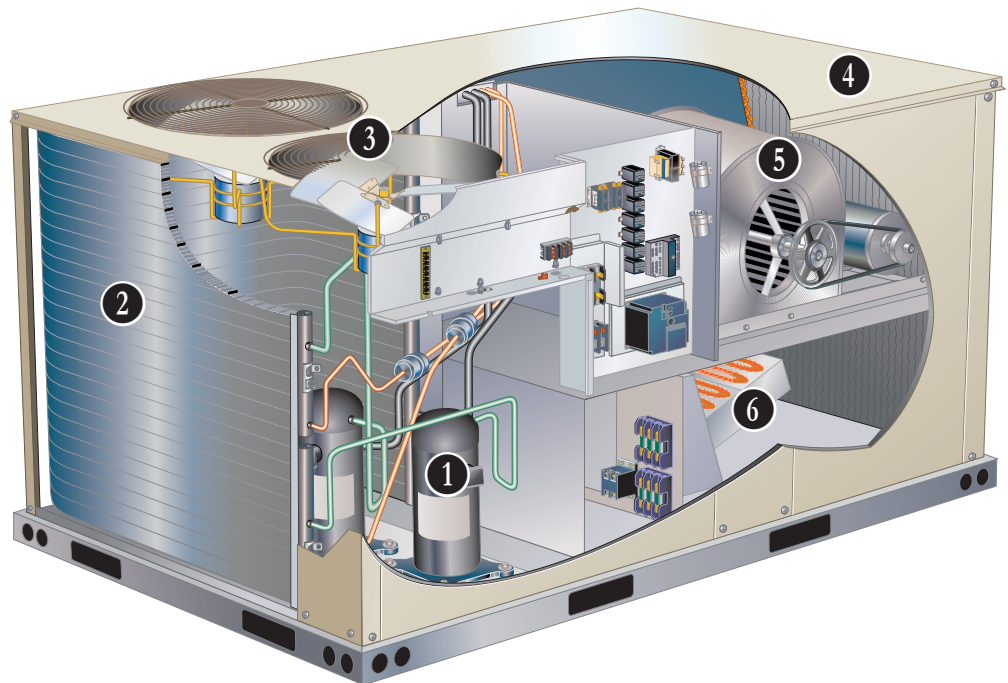

## CONTENTS

Approvals and Warranty . . . . .	3
Blower Data . . . . .	20
Dimensions - Accessories . . . . .	37
Dimensions - Unit . . . . .	36
Electrical/Electric Heat Data . . . . .	26
Electric Heat Capacities . . . . .	34
Features and Benefits . . . . .	3
Model Number Identification. . . . .	1
Optional Conventional Temperature Control Systems . . . . .	10
Options / Accessories . . . . .	11
Outdoor Sound Data . . . . .	34
Ratings . . . . .	16
Specifications . . . . .	14
Unit Clearances . . . . .	34
Weight Data . . . . .	35

## APPROVALS AND WARRANTY

### APPROVALS

- AHRI Standard 340/360 certified
- ETL Intertek listed
- Unit and components ETL, NEC, and CEC bonded for grounding to meet safety standards for servicing
- All models are ASHRAE 90.1-2010 energy efficiency compliant and meet or exceed requirements of Section 6.8
- All models meet DOE 2018 energy efficiency standards
- MSAV® equipped models meet California Code of Regulations, Title 24 and ASHRAE 90.1-2010 Section 6.4.3.10 requirements for staged airflow
- ISO 9001 Registered Manufacturing Quality System

### WARRANTY

- Compressors - Limited five years
- Lennox' Environ™ Coil System - Limited three years
- High Performance Economizers (optional) - Limited five years
- All other covered components - Limited one year

## FEATURES AND BENEFITS

### COOLING SYSTEM

- Designed to maximize sensible and latent cooling performance at design conditions
- System can operate from 40°F (50°F for 150 models) to 125°F without any additional controls

#### R-410A Refrigerant

- Non-chlorine based
- Ozone friendly

#### 1 Scroll Compressors

- Scroll compressors on all models for high performance, reliability and quiet operation
- Resiliently mounted on rubber grommets for quiet operation

#### Refrigerant Metering Orifice

- Accurately meters refrigerant in system
- Refrigerant control is accomplished by exact sizing of refrigerant metering orifice

#### Filter/Driers

- High capacity filter/drier protects the system from dirt and moisture

#### High Pressure Switches

- Protects the compressor from overload conditions such as dirty condenser coils, blocked refrigerant flow, or loss of outdoor fan operation

#### 2 Condenser Coil - Lennox' Environ™ Coil System (092 through 120 models and 150S4M models only)

- Lightweight, all aluminum brazed fin construction
- Constructed of three components:
  - A flat extrusion tube
  - Fins in-between the flat extrusion tube
  - Two refrigerant manifolds

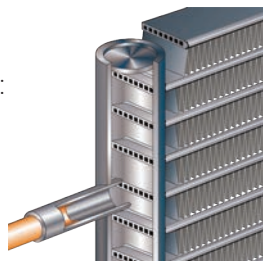

#### Environ™ Coil System Features:

- Improved heat transfer performance due to high primary surface area (flat tubes) versus secondary surface (fins)
- Smaller internal volume (reduced refrigerant charge)
- High durability (all aluminum construction)
- Fewer brazed joints
- Compact design (reduces unit weight)
- Easy maintenance/cleaning
- Face-split design
- Mounting brackets with rubber inserts secure coil to unit providing vibration dampening and corrosion protection

#### Conventional Fin/Tube Condenser Coils (150S4B models only)

- Copper tube construction
- Enhanced rippled-edge aluminum fins
- Flared shoulder tubing connections
- Silver soldered construction

#### Evaporator Coil

- Copper tube construction
- Enhanced rippled-edge aluminum fins
- Flared shoulder tubing connections
- Silver soldered construction
- Factory leak tested
- Cross row circuiting with rifled tubing

#### Condensate Drain Pan

- Plastic pan, sloped to meet drainage requirements per ASHRAE 62.1
- Side drain connections

## FEATURES AND BENEFITS

### **COOLING SYSTEM (continued)**

- 3 Outdoor Coil Fan Motors**
- Thermal overload protected
  - Totally enclosed
  - Permanently lubricated ball bearings
  - Shaft up
  - Wire basket mount

#### **Outdoor Coil Fans**

- PVC coated fan guard furnished

#### **Required Selections**

#### **Cooling Capacity**

- Specify nominal cooling capacity

#### **Options/Accessories**

#### **Field Installed**

##### **Condensate Drain Trap**

- Available in copper or PVC

##### **Drain Pan Overflow Switch**

- Monitors condensate level in drain pan
- Shuts down unit if drain becomes clogged

##### **Low Ambient Kit**

##### **(Includes Compressor Crankcase Heater)**

- Cycles the outdoor fans while allowing compressor operation in the cooling cycle
- Intermittent fan operation allows the system to operate without icing the evaporator coil and losing capacity
- Designed for use in ambient temperatures no lower than 0°F
- Controls the compressor crankcase heaters

**NOTE** - Compressor crankcase heater is furnished with the kit and protects against refrigerant migration that can occur during low ambient operation.

### **CABINET**

#### **Construction**

- 4**
- Heavy-gauge steel panels
  - Full perimeter heavy-gauge galvanized steel base rail
  - Base rails have rigging holes
  - Three sides of the base rail have forklift slots
  - Raised edges around duct and power entry openings in the bottom of the unit for water protection

#### **Airflow Choice**

- Units are shipped in downflow (vertical) return air flow configuration

**NOTE** - Units can be field converted to horizontal airflow.

#### **Duct Flanges**

- Provided for horizontal duct attachment

#### **Power Entry**

- Electrical lines can be brought through the unit base or through horizontal access knock-outs

**NOTE** - Optional Bottom Power Entry Kit is available.

#### **Exterior Panels**

- Constructed of heavy-gauge, galvanized steel
- Two-layer enamel paint finish

#### **Insulation**

- Fully insulated with non-hygroscopic fiberglass insulation (conditioned areas)

#### **Access Panels**

- Filter section
- Blower/heating section
- Compressor/controls section
- Recessed handles for easy service access

#### **Options/Accessories**

#### **Factory Installed**

##### **Corrosion Protection**

- Completely flexible immersed coating
- Electrodeposited dry film process (AST ElectroFin E-Coat)
- Meets Mil Spec MIL-P-53084, ASTM B117 Standard Method Salt Spray Testing
- Indoor Corrosion Protection
  - Coated coil
- Outdoor Corrosion Protection
  - Coated coil

#### **Field Installed**

##### **Combination Coil/Hail Guards**

- Heavy gauge steel frame
- Painted to match cabinet
- Expanded metal mesh protects outdoor coil

## FEATURES AND BENEFITS

### **BLOWER**

A wide selection of supply air blower options are available to meet a variety of airflow requirements.

#### **Motor**

- Overload protected
- Ball bearings
- Belt drive motors are offered on all models and are available in several different sizes to maximize air performance

#### **5 Supply Air Blower**

- Forward curved blades
- Double inlet
- Blower wheel statically and dynamically balanced
- Ball bearings
- Adjustable pulley (allows speed change)

#### **Required Selections**

#### **Select Constant Air Volume (CAV) or MSAV® (Multi-Stage Air Volume) Supply Air Blower Option**

- Order blower motor horsepower and drive kit number required when base unit is ordered
- See Drive Kit Specifications Table

#### **CAV Operation**

- Supply air blower provides a constant volume of air

#### **MSAV® Operation**

- Units utilize a Variable Frequency Drive (VFD) to stage the supply air blower airflow
- The VFD alters the frequency and voltage of the power supply to the blower to control blower speed
- The supply air blower has two speeds:
  - Low speed for part-load cooling operation

**NOTE** - Low speed is 67% of high speed

- High speed for full load cooling and all heat modes
- Full speed blower operation is set by adjusting the motor pulley to deliver the desired air volume
- The ventilation speed is selectable between high and low speed

**NOTE** - Part load airflow in cooling mode on MSAV® units should not be set below 220 cfm/nominal full load ton to reduce the risk of evaporator coil freeze-up.

- The VFD has an operational range of -40 to 125°F outdoor air ambient temperature
- Lower operating costs are obtained when the blower is operated on lower speeds

#### **MSAV® Sequence of Operation**

- Blower operates in low speed for mechanical cooling mode (Y1), ventilation mode (G), or free cooling mode
- Blower operates in high speed for any other mode - mechanical cooling (Y1+Y2), free cooling + Y2 or heating (W1 and W1+W2).
- Economizer damper minimum position is fully closed in unoccupied mode.
- In occupied mode, the economizer damper minimum position is determined by the setting of the economizer control.

**NOTE** - Two-minimum fresh-air settings are only available on MSAV® with the High Performance Economizer option.

### **CONTROLS**

#### **Unit Control**

- All control voltage is provided via a 24V (secondary) transformer with built-in circuit breaker protection
- **Heat/Cool Staging** - Capable of up to 2 heat / 2 cool staging with a third party DDC control system or thermostat
- **Low Voltage Terminal Block** - Provides screw terminal connections for thermostat or controller wiring
- **Night Setback Mode** - Saves energy by closing outdoor air dampers and operating supply fan on thermostat demand only

#### **Options/Accessories**

#### **Field Installed**

##### **Smoke Detectors**

**NOTE** - Smoke detectors are not furnished and must be field supplied.

#### **Commercial Control Systems**

##### **L Connection® Network**

- Complete building automation control system for single or multi-zone applications
- Options include local interface, software for local or remote communication, and hardware for networking other control functions
- See L Connection Network Product Specifications Bulletin for details

##### **Thermostats**

- Control system and thermostat options, see page 10.

## FEATURES AND BENEFITS

### **ELECTRICAL**

#### **Marked & Color-Coded Wiring**

- All electrical wiring is color-coded and marked to identify which components it is connecting

#### **Electrical Plugs**

- Positive connection electrical plugs are used to connect common accessories or maintenance parts for easy removal or installation

### **Required Selections**

#### **Voltage Choice**

- Specify when ordering base unit

### **Options/Accessories**

#### **Field Installed**

6

#### **Electric Heat**

- Helix wound nichrome elements
- Individual element limit controls
- Wiring harness

**NOTE** - See Options / Accessories tables for ordering information.

**NOTE** - Unit Fuse Block is required and must be ordered separately. See Electrical / Electric Heat tables for ordering information.

#### **Bottom Power Entry Kit**

- Reduces the number of penetrations in the roof
- Includes bulkhead connectors to provide power and control wiring routing through the roof curb

### **INDOOR AIR QUALITY**

#### **Air Filters**

- Disposable 2 inch filters furnished as standard

### **Options/Accessories**

#### **Field Installed**

#### **Healthy Climate® High Efficiency Air Filters**

- Disposable MERV 8 or MERV 13 (Minimum Efficiency Reporting Value based on ASHRAE 52.2) efficiency 2 inch pleated filters

#### **Replacement Filter Media Kit With Frame**

- Replaces existing pleated filter media
- Includes washable metal mesh screen and metal frame with clip for holding replaceable non-pleated filter

#### **Indoor Air Quality (CO<sub>2</sub>) Sensors**

- Monitors CO<sub>2</sub> levels
- Reports to the Unit Controller which adjusts economizer dampers as needed

## OPTIONS / ACCESSORIES

### **ECONOMIZER**

#### **Factory or Field Installed**

**NOTE** - Downflow Economizer is factory or field installed.  
Horizontal Economizer is field installed only.

#### **Economizer**

##### **(Standard and High Performance Common Features)**

- Downflow or Horizontal models with Barometric Relief Dampers and Hood
- Barometric Relief Dampers allow relief of excess air
- Aluminum blade dampers prevent blow back and outdoor air infiltration during off cycle
- Exhaust hood with bird screen furnished

**NOTE** - Outdoor Air and Barometric Relief Exhaust Hoods are included when economizer is factory installed and are furnished when ordered for field installation.

- Occupied/Unoccupied mode with field furnished setback thermostat
- Demand Control Ventilation (DCV) ready using optional CO<sub>2</sub> sensors
- Single temperature control is furnished with Economizer
- Outdoor air temperature sensor enables Economizer if the outdoor temperature is less than the setpoint of the control

#### **Standard Economizer Features (Not for Title 24)**

- Gear-driven action
- Return air and outdoor air dampers
- Plug-in connections to unit
- Nylon bearings
- Neoprene seals
- 24-volt
- Fully-modulating spring return motor

#### **Standard Economizer Control Module**

The Standard Economizer Control Module can be adjusted to operate based on outdoor air temperatures.



#### **Economizer Controls:**

- **Damper Minimum Position** - Can be set lower than traditional minimum air requirements resulting in cost savings
- **IAQ Sensor** - Signals dampers to modulate and maintain 55°F when CO<sub>2</sub> is higher than the CO<sub>2</sub> setpoint
- **Demand Control Ventilation (DCV) LED** - A steady green Demand Control Ventilation LED indicates the IAQ reading is higher than setpoint and requires more fresh air
- **Free Cool LED** - A steady green LED indicates outdoor air is suitable for free cooling

**NOTE** - Free Cooling runs when outdoor air temperature is lower than the set temperature on the economizer control.

**NOTE:** The Free Cooling default setting for outdoor air temperature sensor is 55°F.

### **ECONOMIZER (continued)**

#### **Factory or Field Installed (continued)**

##### **High Performance Economizer Features**

- Approved for California Title 24 building standards
- Low leakage dampers are Air Movement and Control Association International (AMCA) Class 1A Certified - Maximum 3 CFM per sq. ft. leakage at 1 in. w.g.
- ASHRAE 90.1-2010 compliant
- Gear-driven action
- High torque 24-volt fully-modulating spring return damper motor
- Return air and outdoor air dampers
- Plug-in connections to unit
- Stainless steel bearings
- Enhanced neoprene blade edge seals
- Flexible stainless steel jamb seals minimize air leakage

**NOTE** - High Performance Economizers are not approved for use with enthalpy controls in Title 24 applications.

**NOTE** - The Free Cooling setpoint for Title 24 applications must be set based on the Climate Zone where the system is installed. See Section 140.4 "Prescriptive Requirements for Space Conditioning Systems" of the California Energy Commission's 2013 Building Energy Efficiency Standards. Refer to Installation Instructions for complete setup information and menu parameters available.

##### **High Performance Economizer Control Module**

- Module provides inputs and outputs to control economizer based on parameter settings
- Module automatically detects sensors by polling to determine which sensors are installed in system
- Module displays any alarm messages (fault detection and diagnostics) as an aid in troubleshooting
- Non-volatile memory retains parameter settings in case of power failure
- Keypad with four navigation buttons and LCD screen is furnished for setting economizer parameters
  - Menu Up/Exit (↑) button returns to the main menu
  - Arrow Up ▲ button moves to the previous or next parameter within the selected menu
  - Arrow Down ▼ button moves to the next parameter within the selected menu
  - Select (enter) (↵) button confirms parameter selection



##### **Main Menu Structure:**

- STATUS (economizer and system operation status)
- SETPOINTS (settings for various setpoint parameters)
- SYSTEM SETUP (settings/information about the system)
- ADVANCED SETUP (freeze protection, CO<sub>2</sub> settings, stage 3 delay, and additional calibration settings)
- CHECKOUT (damper positions)
- ALARMS (output signal that can be configured for remote alarm monitoring)

**NOTE** - Refer to Installation Instructions for complete setup information and menu parameters available.

#### **Field Installed**

##### **Single Enthalpy Temperature Control (Not for Title 24)**

- Outdoor air enthalpy sensor enables Economizer if the outdoor enthalpy is less than the setpoint of the control

##### **Differential Enthalpy Control (Not for Title 24)**

- Order two Single Enthalpy Controls
- One is field installed in the return air section, the other in the outdoor air section
- Allows the economizer control board to select between outdoor air or return air, whichever has lower enthalpy



## OPTIONS / ACCESSORIES

### **EXHAUST**

#### **Field Installed**

##### **Horizontal Low Profile Barometric Relief Dampers**

- For use when unit is configured for horizontal applications in a reduced space requiring an Economizer
- Allows relief of excess air
- Aluminum blade dampers prevent blow back and outdoor air infiltration during off cycle
- Field installed in return air duct
- Exhaust hood with bird screen furnished

##### **Power Exhaust Fan**

- Installs internal to unit for downflow applications only with Economizer option
- Provides exhaust air pressure relief
- Interlocked to run when supply air blower is operating
- Fan runs when outdoor air dampers are 50% open (adjustable)
- Motor is overload protected
- Fan is 20 in. diameter
- Five fan blades
- One 1/3 hp motor

**NOTE** - Requires Economizer and Downflow Barometric Relief Dampers.

### **OUTDOOR AIR**

#### **Field Installed**

##### **Outdoor Air Damper**

- Downflow or Horizontal
- Linked mechanical dampers
- 0 to 25% (fixed) outdoor air adjustable
- Installs in unit
- Includes outdoor air hood
- Automatic model features fully modulating spring return damper motor with plug-in connection
- Manual model features a slide damper

**NOTE** - Maximum mixed air temperature in cooling mode is 100°F.

### **ROOF CURBS**

#### **Field Installed**

##### **Hybrid Roof Curbs, Downflow**

- Nail strip furnished; mates to unit
- US National Roofing Contractors approved
- Shipped knocked down
- Interlocking tabs fasten corners together; no tools required
- Can also be fastened together with furnished hardware
- Available in 8, 14, 18, and 24 inch heights

##### **Adaptor Curbs (not shown)**

- Curbs are regionally sourced
- Dimensions will vary based upon the source

**NOTE** - Contact your local sales representative for a detailed cut sheet with applicable dimensions.

### **CEILING DIFFUSERS**

#### **Field Installed**

- Flush or Step-Down
- White powder coat finish on diffuser face and grilles
- Insulated UL listed duct liner
- Diffuser box has collars for duct connection
- Step-down diffusers have double deflection blades
- Flush diffusers have fixed blades
- Provisions for suspending
- Internally sealed to prevent recirculation
- Removable return air grille
- Adapts to T-bar ceiling grids or plaster ceilings

##### **Transitions (Supply and Return)**

**NOTE** - Ceiling Diffuser Transitions are not furnished and must be field fabricated.

## OPTIONAL CONVENTIONAL TEMPERATURE CONTROL SYSTEMS

### ComfortSense® 7500 Commercial 7-Day Programmable Thermostat



- Four-Stage Heating / Two-Stage Cooling
- Universal Multi-Stage
- Intuitive Touchscreen Interface
- Automatic Changeover between Heating and Cooling
- Full Seven-Day Programming
- Four Time Periods Per Day
- Temperature and Humidity Control
- One-Touch Away Mode
- Holiday Scheduling
- Smooth Setback Recovery (SSR)
- Performance Reports
- Notifications/Reminders
- Economizer Relay Control
- Backlit Display
- Wallplate Furnished
- FDD, ASHRAE and IECC Compliant

### ComfortSense® 3000 Commercial 5-2 Day Programmable Thermostat

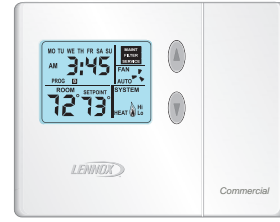

- Two-Stage Heating / Two-Stage Cooling
- Conventional Systems
- Intuitive Interface
- 5-2 Day Programming
- Program Hold
- Remote Indoor Temperature Sensing
- Smooth Setback Recovery (SSR)
- Economizer Relay Control
- Maintenance/Filter/Service Reminders
- Backlit Display
- Wallplate Furnished
- Simple Up and Down Temperature Control

### Bacnet Compatible Thermostat With Reheat Function



Description	Model No.	Catalog No.
<b>ComfortSense® 7500 7-Day Programmable</b>	C0STAT06FF2L	<b>17G74</b>
Universal thermostat locking guard (clear)	C0MISC15AE1-	<b>39P21</b>
<b>Temperature Sensors</b>	<sup>1</sup> Remote non-adjustable wall-mount 20k	<b>47W36</b>
	<sup>1</sup> Remote non-adjustable wall-mount 10k	<b>47W37</b>
	Remote non-adjustable discharge air (duct mount)	<b>19L22</b>
	Outdoor temperature sensor	<b>X2658</b>
<sup>1</sup> Remote wall-mount sensors can be applied in any of the following combinations: One Sensor - (1) 47W36, Two Sensors - (2) 47W37, Three Sensors - (2) 47W36 and (1) 47W37 Four Sensors - (4) 47W36, Five Sensors - (3) 47W36 and (2) 47W37		
<b>ComfortSense® 3000 5-2 Day Programmable</b>	C0STAT05FF1L	<b>11Y05</b>
Thermostat wall mounting plate	C0MISC17AE1-	<b>X2659</b>
<b>Temperature Sensor</b>	Remote non-adjustable wall mount 10k averaging	<b>47W37</b>
<b>BACnet Controls</b>	7-Day BACnet Thermostat	<b>Y8241</b>
	BACnet Module (factory or field)	<b>K0CTRL31B-2</b>
<sup>2</sup> <b>BACnet Room Sensors</b>	With Display	<b>K0SNSR01FF1</b>
	Without Display	<b>K0SNSR00FF1</b>
<b>BACnet Accessories</b>	Plenum Cable (RJ45/CAT5 75 ft.)	<b>K0MISC00FF1</b>

<sup>2</sup> Only compatible with BACnet Module (16X71).

- 7-Day Programmable
- BTL listed MS/TP ensures compatibility with any BACnet system
- Built-in control programs for conventional and heat pump applications
- Conventional systems up to 3-stage heat and 3-stage cool
- Heat pumps with 1 or 2 compressors and up to 2-stage auxiliary heat
- On-board temperature and humidity sensor
- Multiple configurable inputs and outputs enable advanced control strategies
- Set-up Wizard enables rapid system configuration
- No special tools required for installation or commissioning
- Seven-day (2, 4 or 6 event) occupancy scheduling per day
- Backlit 5-inch LCD touchscreen

## OPTIONS / ACCESSORIES

Item Description	Model Number	Catalog Number	Unit Model No			
			092	102	120	150
<b>COOLING SYSTEM</b>						
Condensate Drain Trap	PVC - C1TRAP20AD2	<b>76W26</b>	X	X	X	X
	Copper - C1TRAP10AD2	<b>76W27</b>	X	X	X	X
Corrosion Protection		Factory	O	O	O	O
Drain Pan Overflow Switch	Z1SNSR90A1	<b>99W59</b>	X	X	X	X
Low Ambient Kit (Includes Compressor Crankcase Heater)	208/230V-3ph - Z1LOAM02B-1Y	<b>10Z35</b>	X	X		
	460V-3ph - Z1LOAM02B-1G	<b>10Z36</b>	X	X		
	575V-3ph - Z1LOAM02B-1J	<b>10Z37</b>	X	X		
	208/230V-3ph - Z1LOAM12B-1Y	<b>10Z50</b>			X	X
	460V-3ph - Z1LOAM12B-1G	<b>10Z51</b>			X	X
	575V-3ph - Z1LOAM12B-1J	<b>10Z52</b>			X	X
Refrigerant Type		R-410A	O	O	O	O
<b>BLOWER - SUPPLY AIR</b>						
Blower Option	CAV (Constant Air Volume)	Factory	O	O	O	O
	MSAV® (Multi-Stage Air Volume)	Factory	O	O	O	O
Blower Motors	Belt Drive - 2 hp	Factory	O	O	O	O
	Belt Drive - 3 hp	Factory	O	O	O	O
	Belt Drive - 5 hp	Factory	O	O	O	O
Drive Kits See Blower Data Tables for selection	Kit #1 590-890 rpm	Factory	O	O	O	O
	Kit #2 800-1105 rpm	Factory	O	O	O	O
	Kit #3 795-1195 rpm	Factory	O	O	O	O
	Kit #4 730-970 rpm	Factory	O	O	O	O
	Kit #5 940-1200 rpm	Factory	O	O	O	O
	Kit #6 1015-1300 rpm	Factory	O	O	O	O
	Kit #10 900-1135 rpm	Factory	O	O	O	O
	Kit #11 1040-1315 rpm	Factory	O	O	O	O
	Kit #12 1125-1425 rpm	Factory	O	O	O	O
<b>CABINET</b>						
Combination Coil/Hail Guards	Z1GARD52B-1	<b>12X21</b>	X	X	X	X
<b>CONTROLS</b>						
<b>NOTE - Also see Conventional Thermostat Control Systems on page 10 for Additional Options.</b>						
	L Connection® Building Automation System	- - -	X	X	X	X

NOTE - Catalog and model numbers shown are for ordering field installed accessories.

OX - Configure To Order (Factory Installed) or Field Installed

O = Configure To Order (Factory Installed)

X = Field Installed

## OPTIONS / ACCESSORIES

Item Description	Model Number	Catalog Number	Unit Model No			
			092	102	120	150
<b>INDOOR AIR QUALITY</b>						
<b>Air Filters</b>						
Healthy Climate® High Efficiency Air Filters 20 x 24 x 2 (Order 4 per unit)	MERV 8 - Z1FLTR15B-1	<b>14C35</b>	X	X	X	X
	MERV 13 - Z1FLTR40B-1	<b>14C36</b>	X	X	X	X
Replacement Media Filter With Metal Mesh Frame (includes non-pleated filter media)	C1FLTR30B-1-	<b>Y3063</b>	X	X	X	X
<b>Indoor Air Quality (CO<sub>2</sub>) Sensors</b>						
Sensor - Wall-mount, off-white plastic cover with LCD display	C0SNSR50AE1L	<b>77N39</b>	X	X	X	X
Sensor - Wall-mount, off-white plastic cover, no display	C0SNSR52AE1L	<b>87N53</b>	X	X	X	X
Sensor - Black plastic case with LCD display, rated for plenum mounting	C0SNSR51AE1L	<b>87N52</b>	X	X	X	X
Sensor - Wall-mount, black plastic case, no display, rated for plenum mounting	C0MISC19AE1	<b>87N54</b>	X	X	X	X
CO <sub>2</sub> Sensor Duct Mounting Kit - for downflow applications	C0MISC19AE1-	<b>85L43</b>	X	X	X	X
Aspiration Box - for duct mounting non-plenum rated CO <sub>2</sub> sensors (87N53 or 77N39)	C0MISC16AE1-	<b>90N43</b>	X	X	X	X
<b>ELECTRICAL</b>						
Voltage 60 hz	208/230V - 3 phase	Factory	O	O	O	O
	460V - 3 phase	Factory	O	O	O	O
	575V - 3 phase	Factory	O	O	O	O
Bottom Power Entry Kit	Z1PEKT01B-1	<b>11H66</b>	X	X	X	X
<b>ELECTRIC HEAT</b>						
7.5 kW	208/230V-3ph - Z1EH0075B-1Y	<b>10Y97</b>	X	X		
	460V-3ph - Z1EH0075B-1G	<b>10Y98</b>	X	X		
	575V-3ph - Z1EH0075B-1J	<b>10Y99</b>	X	X		
15 kW	208/230V-3ph - Z1EH0150B-1Y	<b>10Z01</b>	X	X	X	X
	460V-3ph - Z1EH0150B-1G	<b>10Z03</b>	X	X	X	X
	575V-3ph - Z1EH0150B-1J	<b>10Z04</b>	X	X	X	X
22.5 kW	208/230V-3ph - Z1EH0225B-1Y	<b>10Z05</b>	X	X	X	X
	460V-3ph - Z1EH0225B-1G	<b>10Z06</b>	X	X	X	X
	575V-3ph - Z1EH0225B-1J	<b>10Z07</b>	X	X	X	X
30 kW	208/230V-3ph - Z1EH0300B-1Y	<b>10Z08</b>	X	X	X	X
	460V-3ph - Z1EH0300B-1G	<b>10Z09</b>	X	X	X	X
	575V-3ph - Z1EH0300B-1J	<b>10Z10</b>	X	X	X	X
45 kW	208/230V-3ph - Z1EH0450B-1Y	<b>10Z11</b>	X	X	X	X
	460V-3ph - Z1EH0450B-1G	<b>10Z12</b>	X	X	X	X
	575V-3ph - Z1EH0450B-1J	<b>10Z13</b>	X	X	X	X
60 kW	208/230V-3ph - Z1EH0600B-1Y	<b>10Z14</b>			X	X
	460V-3ph - Z1EH0600B-1G	<b>10Z15</b>			X	X
	575V-3ph - Z1EH0600B-1J	<b>10Z16</b>			X	X
<b>ELECTRIC HEAT ACCESSORIES</b>						
Unit Fuse Block (required) - See Electrical/Electric Heat Tables for Selection			X	X	X	X

NOTE - Catalog and model numbers shown are for ordering field installed accessories.

OX - Configure To Order (Factory Installed) or Field Installed

O = Configure To Order (Factory Installed)

X = Field Installed

## OPTIONS / ACCESSORIES

Item Description	Model Number	Catalog Number	Unit Model No			
			092	102	120	150
<b>ECONOMIZER</b>						
<b>Standard Economizer (Not for Title 24)</b>						
Standard Downflow Economizer with Single Temperature Control - With Barometric Relief Dampers and Air Hoods	Z1ECON30B-1	<b>10Z29</b>	OX	OX	OX	OX
Standard Horizontal Economizer with Single Temperature Control - With Barometric Relief Dampers and Air Hoods	Z1ECON16B-1	<b>11G98</b>	X	X	X	X
<b>Standard Economizer Controls (Not for Title 24)</b>						
Single Enthalpy Control	C1SNSR64FF1	<b>53W64</b>	X	X	X	X
Differential Enthalpy Control (order 2)	C1SNSR64FF1	<b>53W64</b>	X	X	X	X
<b>High Performance Economizer (Approved for California Title 24 Building Standards / AMCA Class 1A Certified)</b>						
High Performance Downflow Economizer with Single Temperature Control - With Barometric Relief Dampers and Air Hoods	Z1ECON32B-2	<b>16X73</b>	OX	OX	OX	OX
High Performance Horizontal Economizer with Single Temperature Control - With Barometric Relief Dampers and Air Hoods	Z1ECON33B-2	<b>16X74</b>	X	X	X	X
<b>High Performance Economizer Controls (Not for Title 24)</b>						
Single Enthalpy Control	C1SNSR61FF1	<b>11G21</b>	X	X	X	X
Differential Enthalpy Control (order 2)	C1SNSR61FF1	<b>11G21</b>	X	X	X	X
<b>Horizontal Low Profile Barometric Relief Dampers With Exhaust Hood</b>						
Horizontal Low Profile Barometric Relief Dampers With Exhaust Hood	LAGEDH03/15	<b>53K04</b>	X	X	X	X
<b>OUTDOOR AIR</b>						
<b>Outdoor Air Dampers</b>						
Motorized Dampers with outdoor air hood	Z1DAMP20B-2	<b>14G36</b>	X	X	X	X
Manual Dampers with outdoor air hood	Z1DAMP10B-2	<b>14G37</b>	X	X	X	X
<b>POWER EXHAUST</b>						
Standard Static (Downflow)	208/230V-3ph - Z1PWRE10B-1Y	<b>10Z70</b>	X	X	X	X
	460V-3ph - Z1PWRE10B-1G	<b>10Z71</b>	X	X	X	X
Standard Static (Horizontal)	208/230V-3ph - Z1PWRE15A-1P	<b>24E01</b>	X	X	X	X
	460V-3ph - Z1PWRE15A-1G	<b>28E01</b>	X	X	X	X
575V Transformer Kit	575V-3ph - Z1TRFM20A-1J	<b>59E02</b>	X	X	X	X
NOTE - Order 575V Transformer Kit with 208/230V Power Exhaust Fan for 575V applications. Order two kits for downflow models, order one kit for horizontal models.						
<b>ROOF CURBS</b>						
<b>Hybrid Roof Curbs, Downflow</b>						
8 in. height	Z1CURB40B-1	<b>10Z25</b>	X	X	X	X
14 in. height	Z1CURB41B-1	<b>10Z26</b>	X	X	X	X
18 in. height	Z1CURB42B-1	<b>10Z27</b>	X	X	X	X
24 in. height	Z1CURB43B-1	<b>10Z28</b>	X	X	X	X
<b>CEILING DIFFUSERS</b>						
Step-Down - Order one	RTD11-95S	<b>13K61</b>	X			
	RTD11-135S	<b>13K62</b>		X	X	
	RTD11-185S	<b>13K63</b>				X
Flush - Order one	FD11-95S	<b>13K56</b>	X			
	FD11-135S	<b>13K57</b>		X	X	
	FD11-185S	<b>13K58</b>				X

NOTE - Ceiling Diffuser Transitions are not furnished and must be field fabricated.

NOTE - Catalog and model numbers shown are for ordering field installed accessories.

OX - Configure To Order (Factory Installed) or Field Installed

O = Configure To Order (Factory Installed)

X = Field Installed

**SPECIFICATIONS**

**7.5 - 8.5 TON**

General Data		Nominal Tonnage	7.5 Ton	7.5 Ton	8.5 Ton	8.5 Ton
		<b>Model Number</b>	<b>ZCB092S4B</b>	<b>ZCA092S4M</b>	<b>ZCB102S4B</b>	<b>ZCA102S4M</b>
		<b>Efficiency Type</b>	<b>Standard</b>	<b>Standard</b>	<b>Standard</b>	<b>Standard</b>
		<b>Blower Type</b>	Constant Air Volume (CAV)	MSAV® (Multi-Stage Air Volume)	Constant Air Volume (CAV)	MSAV® (Multi-Stage Air Volume)
<b>Cooling Performance</b>	Gross Cooling Capacity - Btuh		91,100	88,200	99,900	99,900
	<sup>1</sup> Net Cooling Capacity - Btuh		88,000	86,000	97,000	97,000
	AHRI Rated Air Flow - cfm		2,750	2,800	3,250	3,250
	Total Unit Power - kW		8.0	7.7	8.8	8.7
	<sup>1</sup> EER (Btuh/Watt)		11.2	11.2	11.2	11.2
	<sup>1</sup> IEER (Btuh/Watt)		12.9	13.2	12.9	13.2
<b>Refrigerant Charge Furnished</b>	Refrigerant Type		R-410A	R-410A	R-410A	R-410A
	Circuit 1		4 lbs. 7 oz.	4 lbs. 7 oz.	4 lbs. 13 oz.	4 lbs. 13 oz.
	Circuit 2		3 lbs. 1 oz.	3 lbs. 1 oz.	4 lbs. 10 oz.	4 lbs. 10 oz.
<b>Electric Heat Available - See page 12</b>			7.5, 15, 22.5, 30 & 45 kW			
<b>Compressor Type (number)</b>			Scroll (2)	Scroll (2)	Scroll (2)	Scroll (2)
<b>Outdoor Coils</b>	Net face area (total) - sq. ft.		20.9	20.9	20.9	20.9
	Number of rows		1	1	1	1
	Fins per inch		23	23	23	23
<b>Outdoor Coil Fans</b>	Motor - (No.) hp		(2) 1/3	(2) 1/3	(2) 1/3	(2) 1/3
	Motor rpm		1075	1075	1075	1075
	Total Motor watts		740	740	740	740
	Diameter - (No.) in.		(2) 24	(2) 24	(2) 24	(2) 24
	Number of blades		3	3	3	3
	Total Air volume - cfm		8800	8800	8800	8800
<b>Indoor Coils</b>	Net face area (total) - sq. ft.		12.78	12.78	12.78	12.78
	Tube diameter - in.		3/8	3/8	3/8	3/8
	Number of rows		2	2	3	3
	Fins per inch		14	14	14	14
Drain connection - Number and size			(1) 1 in. NPT coupling			
Expansion device type			Refrigerant Metering Orifice (RFC)			
<sup>2</sup> <b>Indoor Blower and Drive Selection</b>	Nominal motor output		2 hp, 3 hp, 5 hp			
	Maximum usable motor output (US Only)		2.3 hp, 3.45 hp, 5.75 hp			
	Motor - Drive kit number		2 hp Kit 1 590-890 rpm Kit 2 800-1105 rpm Kit 3 795-1195 rpm 3 hp Kit 4 730-970 rpm Kit 5 940-1200 rpm Kit 6 1015-1300 rpm 5 hp Kit 10 900-1135 rpm Kit 11 1040-1315 rpm Kit 12 1125-1425 rpm			
Blower wheel nominal diameter x width - in.			(1) 15 X 15	(1) 15 X 15	(1) 15 X 15	(1) 15 X 15
<b>Filters</b>	Type of filter		Disposable			
	Number and size - in.		(4) 20 x 24 x 2			
<b>Electrical characteristics</b>			208/230V, 460V or 575V - 60 hertz - 3 phase			

NOTE - Net capacity includes evaporator blower motor heat deduction. Gross capacity does not include evaporator blower motor heat deduction.

<sup>1</sup> AHRI Certified to AHRI Standard 340/360; 95°F outdoor air temperature and 80°F db/67°F wb entering evaporator air; minimum external duct static pressure.

<sup>2</sup> Using total air volume and system static pressure requirements determine from blower performance tables rpm and motor output required. Maximum usable output of motors furnished are shown. In Canada, nominal motor output is also maximum usable motor output. If motors of comparable output are used, be sure to keep within the service factor limitations outlined on the motor nameplate.

NOTE – Units equipped with MSAV® (Multi-Stage Air Volume) option are limited to a motor service factor of 1.0.

**SPECIFICATIONS**

**10 - 12.5 TON**

General Data		Nominal Tonnage	10 Ton	10 Ton	12.5 Ton	12.5 Ton
		<b>Model Number</b>	<b>ZCB120S4B</b>	<b>ZCA120S4M</b>	<b>ZCB150S4B</b>	<b>ZCA150S4M</b>
		<b>Efficiency Type</b>	<b>Standard</b>	<b>Standard</b>	<b>Standard</b>	<b>Standard</b>
		<b>Blower Type</b>	Constant Air Volume (CAV)	MSAV® (Multi-Stage Air Volume)	Constant Air Volume (CAV)	MSAV® (Multi-Stage Air Volume)
<b>Cooling Performance</b>	Gross Cooling Capacity - Btuh		119,000	118,400	143,000	142,000
	<sup>1</sup> Net Cooling Capacity - Btuh		115,000	115,000	136,000	136,000
	AHRI Rated Air Flow - cfm		3100	3,800	3,700	4,400
	Total Unit Power - kW		10.3	10.3	12.7	12.4
	<sup>1</sup> EER (Btuh/Watt)		11.2	11.2	11.0	11.0
	<sup>1</sup> IEER (Btuh/Watt)		12.9	13.2	12.4	12.4
<b>Refrigerant Charge Furnished</b>	Refrigerant Type		R-410A	R-410A	R-410A	R-410A
	Circuit 1		6 lbs. 4 oz.	5 lbs 0 oz.	12 lbs. 6 oz.	7 lbs 0 oz.
	Circuit 2		5 lbs. 7 oz.	5 lbs 4 oz.	13 lbs. 6 oz.	6 lbs 12 oz.
<b>Electric Heat Available - See page 12</b>			15, 22.5, 30, 45 and 60 KW			
<b>Compressor Type (number)</b>			Scroll (2)	Scroll (2)	Scroll (2)	Scroll (2)
<b>Outdoor Coils</b>	Net face area (total) - sq. ft.		28.0	28.0	27.8	28.0
	Number of rows		1	1	3	1
	Fins per inch		23	23	20	20
<b>Outdoor Coil Fans</b>	Motor - (No.) hp		(2) 1/3	(2) 1/3	(2) 1/2	(2) 1/2
	Motor rpm		1075	1075	1075	1075
	Total Motor watts		700	700	910	950
	Diameter - (No.) in.		(2) 24	(2) 24	(2) 24	(2) 24
	Number of blades		3	3	3	3
	Total Air volume - cfm		9000	9000	9000	9600
<b>Indoor Coils</b>	Net face area (total) - sq. ft.		13.54	13.54	13.54	13.54
	Tube diameter - in.		3/8	3/8	3/8	3/8
	Number of rows		4	3	4	4
	Fins per inch		14	14	14	14
	Drain connection - Number and size		(1) 1 in. NPT coupling			
Expansion device type			Refrigerant Metering Orifice (RFC)			
<b><sup>2</sup> Indoor Blower and Drive Selection</b>	Nominal motor output		2 hp, 3 hp, 5 hp			
	Maximum usable motor output (US Only)		2.3 hp, 3.45 hp, 5.75 hp			
	Motor - Drive kit number		2 hp Kit 1 590-890 rpm Kit 2 800-1105 rpm Kit 3 795-1195 rpm 3 hp Kit 4 730-970 rpm Kit 5 940-1200 rpm Kit 6 1015-1300 rpm 5 hp Kit 10 900-1135 rpm Kit 11 1040-1315 rpm Kit 12 1125-1425 rpm			
	Blower wheel nominal diameter x width - in.		(1) 15 X 15	(1) 15 X 15	(1) 15 X 15	(1) 15 X 15
<b>Filters</b>	Type of filter		Disposable			
	Number and size - in.		(4) 20 x 24 x 2			
<b>Electrical characteristics</b>			208/230V, 460V or 575V - 60 hertz - 3 phase			

NOTE - Net capacity includes evaporator blower motor heat deduction. Gross capacity does not include evaporator blower motor heat deduction.  
 1 AHRI Certified to AHRI Standard 340/360; 95°F outdoor air temperature and 80°F db/67°F wb entering evaporator air; minimum external duct static pressure.  
 2 Using total air volume and system static pressure requirements determine from blower performance tables rpm and motor output required. Maximum usable output of motors furnished are shown. In Canada, nominal motor output is also maximum usable motor output. If motors of comparable output are used, be sure to keep within the service factor limitations outlined on the motor nameplate.  
 NOTE – Units equipped with MSAV® (Multi-Stage Air Volume)option are limited to a motor service factor of 1.0.

# RATINGS

NOTE - For Temperatures and Capacities not shown in tables, see bulletin - Cooling Unit Rating Table Correction Factor Data in Miscellaneous Engineering Data section.

## 7.5 TON STANDARD EFFICIENCY ZCB092S4B (1ST STAGE) - CONSTANT AIR VOLUME

Entering Wet Bulb Temperature	Total Air Volume	Outdoor Air Temperature Entering Outdoor Coil																							
		65°F						75°F						85°F						95°F					
		Total Cool Cap.	Comp. Motor Input	Sensible To Total Ratio (S/T)			Total Cool Cap.	Comp. Motor Input	Sensible To Total Ratio (S/T)			Total Cool Cap.	Comp. Motor Input	Sensible To Total Ratio (S/T)			Total Cool Cap.	Comp. Motor Input	Sensible To Total Ratio (S/T)						
				Dry Bulb					Dry Bulb					Dry Bulb					Dry Bulb						
cfm	kBtuh	kW	75°F	80°F	85°F	kBtuh	kW	75°F	80°F	85°F	kBtuh	kW	75°F	80°F	85°F	kBtuh	kW	75°F	80°F	85°F					
63°F	2400	63.6	2.73	0.66	0.77	0.9	60.9	3.06	0.66	0.78	0.91	57.8	3.43	0.67	0.8	0.93	54.5	3.86	0.68	0.82	0.96				
	3000	67.1	2.76	0.69	0.83	0.96	64.3	3.08	0.7	0.84	0.98	61.1	3.45	0.71	0.86	0.99	57.6	3.88	0.72	0.88	1				
	3600	70.2	2.78	0.72	0.88	1	67.1	3.1	0.73	0.89	1	63.7	3.47	0.74	0.91	1	60	3.9	0.76	0.94	1				
67°F	2400	66.8	2.76	0.53	0.64	0.74	64	3.08	0.54	0.64	0.75	60.9	3.45	0.54	0.65	0.76	57.4	3.88	0.54	0.66	0.78				
	3000	70.7	2.79	0.55	0.67	0.79	67.5	3.1	0.56	0.67	0.81	64.1	3.47	0.56	0.68	0.82	60.5	3.91	0.56	0.7	0.85				
	3600	73.5	2.8	0.57	0.7	0.84	70.2	3.12	0.57	0.71	0.86	66.6	3.49	0.58	0.72	0.88	62.6	3.92	0.58	0.74	0.9				
71°F	2400	69.7	2.78	0.42	0.52	0.61	66.8	3.1	0.42	0.52	0.62	63.6	3.47	0.41	0.52	0.63	60.1	3.9	0.4	0.53	0.64				
	3000	73.9	2.81	0.43	0.54	0.65	70.6	3.12	0.43	0.54	0.65	67.1	3.5	0.42	0.55	0.66	63.3	3.93	0.41	0.55	0.68				
	3600	77	2.83	0.44	0.56	0.68	73.5	3.14	0.44	0.56	0.69	69.6	3.51	0.41	0.57	0.7	65.6	3.95	0.42	0.57	0.72				

## 7.5 TON STANDARD EFFICIENCY ZCB092S4B (2ND STAGE) - CONSTANT AIR VOLUME

Entering Wet Bulb Temperature	Total Air Volume	Outdoor Air Temperature Entering Outdoor Coil																							
		85°F						95°F						105°F						115°F					
		Total Cool Cap.	Comp. Motor Input	Sensible To Total Ratio (S/T)			Total Cool Cap.	Comp. Motor Input	Sensible To Total Ratio (S/T)			Total Cool Cap.	Comp. Motor Input	Sensible To Total Ratio (S/T)			Total Cool Cap.	Comp. Motor Input	Sensible To Total Ratio (S/T)						
				Dry Bulb					Dry Bulb					Dry Bulb					Dry Bulb						
cfm	kBtuh	kW	75°F	80°F	85°F	kBtuh	kW	75°F	80°F	85°F	kBtuh	kW	75°F	80°F	85°F	kBtuh	kW	75°F	80°F	85°F					
63°F	2400	86	5.76	0.68	0.82	0.96	80.6	6.5	0.69	0.84	0.98	74.8	7.36	0.71	0.87	1	68.6	8.33	0.73	0.9	1				
	3000	90.8	5.8	0.73	0.89	1	85	6.54	0.74	0.92	1	78.8	7.4	0.76	0.95	1	72.2	8.38	0.79	0.98	1				
	3600	94.4	5.82	0.77	0.95	1	88.3	6.57	0.79	0.98	1	82	7.43	0.82	0.99	1	75.5	8.42	0.85	1	1				
67°F	2400	90.7	5.79	0.54	0.66	0.78	85.2	6.54	0.54	0.67	0.8	79.3	7.4	0.55	0.69	0.83	72.7	8.38	0.56	0.7	0.86				
	3000	96	5.83	0.57	0.7	0.85	89.9	6.58	0.57	0.72	0.88	83.5	7.45	0.58	0.74	0.91	76.7	8.43	0.59	0.77	0.95				
	3600	99.7	5.85	0.59	0.75	0.92	93.4	6.61	0.6	0.77	0.95	86.6	7.48	0.61	0.79	0.98	79.3	8.47	0.63	0.83	1				
71°F	2400	95	5.82	0.41	0.53	0.64	89.5	6.58	0.41	0.53	0.65	83.3	7.44	0.4	0.54	0.66	76.7	8.43	0.4	0.55	0.68				
	3000	100.7	5.86	0.43	0.56	0.68	94.5	6.62	0.42	0.56	0.7	87.9	7.49	0.41	0.57	0.72	80.8	8.48	0.41	0.58	0.74				
	3600	104.7	5.89	0.43	0.58	0.72	98.1	6.65	0.43	0.59	0.74	91.2	7.52	0.43	0.6	0.77	83.8	8.52	0.43	0.62	0.8				

## 7.5 TON STANDARD EFFICIENCY ZCA092S4M (1ST STAGE) - MSAV® (Multi-Stage Air Volume) SUPPLY AIR BLOWER

Entering Wet Bulb Temperature	Total Air Volume	Outdoor Air Temperature Entering Outdoor Coil																							
		65°F						75°F						85°F						95°F					
		Total Cool Cap.	Comp. Motor Input	Sensible To Total Ratio (S/T)			Total Cool Cap.	Comp. Motor Input	Sensible To Total Ratio (S/T)			Total Cool Cap.	Comp. Motor Input	Sensible To Total Ratio (S/T)			Total Cool Cap.	Comp. Motor Input	Sensible To Total Ratio (S/T)						
				Dry Bulb					Dry Bulb					Dry Bulb					Dry Bulb						
cfm	kBtuh	kW	75°F	80°F	85°F	kBtuh	kW	75°F	80°F	85°F	kBtuh	kW	75°F	80°F	85°F	kBtuh	kW	75°F	80°F	85°F					
63°F	1680	55.5	2.71	0.63	0.73	0.82	53.2	3.05	0.63	0.73	0.83	50.8	3.42	0.64	0.74	0.84	48	3.86	0.64	0.75	0.86				
	2100	59.7	2.75	0.66	0.76	0.87	57.2	3.08	0.66	0.77	0.88	54.3	3.45	0.66	0.78	0.9	51.3	3.88	0.67	0.8	0.92				
	2520	62.7	2.77	0.68	0.8	0.92	60	3.1	0.69	0.81	0.93	57	3.47	0.69	0.82	0.95	53.7	3.9	0.7	0.84	0.97				
67°F	1680	58.2	2.73	0.51	0.61	0.7	55.8	3.06	0.51	0.61	0.7	53.2	3.44	0.52	0.61	0.71	50.4	3.88	0.52	0.62	0.72				
	2100	62.5	2.77	0.53	0.63	0.73	59.9	3.09	0.54	0.64	0.74	57.1	3.47	0.54	0.64	0.75	53.9	3.9	0.54	0.65	0.76				
	2520	65.9	2.79	0.55	0.65	0.77	63	3.12	0.55	0.66	0.78	59.9	3.49	0.55	0.67	0.79	56.5	3.93	0.56	0.68	0.81				
71°F	1680	60.8	2.75	0.41	0.49	0.58	58.4	3.08	0.4	0.49	0.59	55.6	3.46	0.4	0.5	0.59	52.6	3.89	0.4	0.5	0.6				
	2100	65.3	2.79	0.42	0.52	0.61	62.6	3.11	0.42	0.52	0.61	59.6	3.49	0.42	0.52	0.62	56.3	3.92	0.41	0.53	0.63				
	2520	68.8	2.81	0.43	0.53	0.63	65.9	3.14	0.43	0.54	0.64	62.6	3.51	0.43	0.54	0.65	59.1	3.95	0.42	0.55	0.66				

## 7.5 TON STANDARD EFFICIENCY ZCA092S4M (2ND STAGE) - MSAV® (Multi-Stage Air Volume) SUPPLY AIR BLOWER

Entering Wet Bulb Temperature	Total Air Volume	Outdoor Air Temperature Entering Outdoor Coil																							
		85°F						95°F						105°F						115°F					
		Total Cool Cap.	Comp. Motor Input	Sensible To Total Ratio (S/T)			Total Cool Cap.	Comp. Motor Input	Sensible To Total Ratio (S/T)			Total Cool Cap.	Comp. Motor Input	Sensible To Total Ratio (S/T)			Total Cool Cap.	Comp. Motor Input	Sensible To Total Ratio (S/T)						
				Dry Bulb					Dry Bulb					Dry Bulb					Dry Bulb						
cfm	kBtuh	kW	75°F	80°F	85°F	kBtuh	kW	75°F	80°F	85°F	kBtuh	kW	75°F	80°F	85°F	kBtuh	kW	75°F	80°F	85°F					
63°F	2400	86	5.76	0.68	0.82	0.96	80.6	6.5	0.69	0.84	0.98	74.8	7.36	0.71	0.87	1	68.6	8.33	0.73	0.9	1				
	3000	90.8	5.8	0.73	0.89	1	85	6.54	0.74	0.92	1	78.8	7.4	0.76	0.95	1	72.2	8.38	0.79	0.98	1				
	3600	94.4	5.82	0.77	0.95	1	88.3	6.57	0.79	0.98	1	82	7.43	0.82	0.99	1	75.5	8.42	0.85	1	1				
67°F	2400	90.7	5.79	0.54	0.66	0.78	85.2	6.54	0.54	0.67	0.8	79.3	7.4	0.55	0.69	0.83	72.7	8.38	0.56	0.7	0.86				
	3000	96	5.83	0.57	0.7	0.85	89.9	6.58	0.57	0.72	0.88	83.5	7.45	0.58	0.74	0.91	76.7	8.43	0.59	0.77	0.95				
	3600	99.7	5.85	0.59	0.75	0.92	93.4	6.61	0.6	0.77	0.95	86.6	7.48	0.61	0.79	0.98	79.3	8.47	0.63	0.83	1				
71°F	2400	95	5.82	0.41	0.53	0.64	89.5	6.58	0.41	0.53	0.65	83.3	7.44	0.4	0.54	0.66	76.7	8.43	0.4	0.55	0.68				
	3000	100.7	5.86	0.43	0.56	0.68	94.5	6.62	0.42	0.56	0.7	87.9	7.49	0.41	0.57	0.72	80.8	8.48	0.41	0.58	0.74				
	3600	104.7	5.89	0.43	0.58	0.72	98.1	6.65	0.43	0.59	0.74	91.2	7.52	0.43	0.6	0.77	83.8	8.52	0.43	0.62	0.8				



# RATINGS

NOTE – For Temperatures and Capacities not shown in tables, see bulletin – Cooling Unit Rating Table Correction Factor Data in Miscellaneous Engineering Data section.

## 8.5 TON STANDARD EFFICIENCY ZCB102S4B (1ST STAGE) - CONSTANT AIR VOLUME

Entering Wet Bulb Temperature	Total Air Volume	Outdoor Air Temperature Entering Outdoor Coil																			
		65°F					75°F					85°F					95°F				
		Total Cool Cap.	Comp. Motor Input	Sensible To Total Ratio (S/T)			Total Cool Cap.	Comp. Motor Input	Sensible To Total Ratio (S/T)			Total Cool Cap.	Comp. Motor Input	Sensible To Total Ratio (S/T)			Total Cool Cap.	Comp. Motor Input	Sensible To Total Ratio (S/T)		
				Dry Bulb					Dry Bulb					Dry Bulb					Dry Bulb		
cfm	kBtuh	kW	75°F	80°F	85°F	kBtuh	kW	75°F	80°F	85°F	kBtuh	kW	75°F	80°F	85°F	kBtuh	kW	75°F	80°F	85°F	
63°F	2720	66.4	2.72	0.68	0.8	0.92	63.8	3.1	0.68	0.81	0.94	61	3.52	0.69	0.83	0.95	58.1	3.98	0.7	0.84	0.97
	3400	69.8	2.74	0.7	0.85	0.97	67.1	3.13	0.71	0.86	0.97	64.1	3.55	0.72	0.88	0.97	60.9	4.01	0.74	0.9	0.96
	4080	72.5	2.75	0.73	0.9	0.96	69.5	3.15	0.74	0.91	0.96	66.3	3.57	0.75	0.93	0.96	62.8	4.03	0.77	0.95	0.96
67°F	2720	69.5	2.74	0.53	0.65	0.76	66.8	3.12	0.53	0.65	0.78	63.9	3.55	0.54	0.67	0.79	60.8	4.01	0.54	0.68	0.81
	3400	73.1	2.76	0.54	0.68	0.81	70.2	3.15	0.54	0.69	0.83	67.1	3.57	0.55	0.7	0.84	63.7	4.04	0.56	0.71	0.86
	4080	75.8	2.77	0.55	0.71	0.86	72.7	3.16	0.55	0.72	0.87	69.3	3.59	0.56	0.73	0.89	65.6	4.05	0.56	0.74	0.91
71°F	2720	72.9	2.76	0.39	0.5	0.62	69.6	3.15	0.39	0.51	0.63	66.5	3.57	0.39	0.52	0.64	63.3	4.03	0.39	0.52	0.65
	3400	76.1	2.77	0.38	0.52	0.65	73.1	3.17	0.38	0.53	0.66	69.8	3.59	0.39	0.53	0.67	66	4.06	0.39	0.54	0.68
	4080	78.7	2.78	0.38	0.53	0.68	75.4	3.18	0.38	0.54	0.69	71.7	3.6	0.38	0.54	0.7	67.8	4.07	0.38	0.55	0.72

## 8.5 TON STANDARD EFFICIENCY ZCB102S4B (2ND STAGE) - CONSTANT AIR VOLUME

Entering Wet Bulb Temperature	Total Air Volume	Outdoor Air Temperature Entering Outdoor Coil																			
		85°F					95°F					105°F					115°F				
		Total Cool Cap.	Comp. Motor Input	Sensible To Total Ratio (S/T)			Total Cool Cap.	Comp. Motor Input	Sensible To Total Ratio (S/T)			Total Cool Cap.	Comp. Motor Input	Sensible To Total Ratio (S/T)			Total Cool Cap.	Comp. Motor Input	Sensible To Total Ratio (S/T)		
				Dry Bulb					Dry Bulb					Dry Bulb					Dry Bulb		
cfm	kBtuh	kW	75°F	80°F	85°F	kBtuh	kW	75°F	80°F	85°F	kBtuh	kW	75°F	80°F	85°F	kBtuh	kW	75°F	80°F	85°F	
63°F	2720	95.7	6.57	0.75	0.87	0.97	90.6	7.42	0.77	0.89	0.98	85.2	8.37	0.78	0.91	0.99	79.2	9.44	0.8	0.94	0.98
	3400	100.3	6.62	0.8	0.92	0.98	94.8	7.47	0.81	0.94	0.98	89.2	8.42	0.83	0.96	0.98	83.1	9.5	0.85	0.98	0.98
	4080	104	6.66	0.83	0.96	0.98	98.6	7.51	0.85	0.97	0.98	92.9	8.47	0.87	0.98	0.98	87.1	9.56	0.9	0.97	0.98
67°F	2720	101.3	6.63	0.59	0.72	0.84	96	7.48	0.6	0.74	0.86	90.3	8.44	0.61	0.76	0.88	84	9.51	0.62	0.78	0.91
	3400	106.4	6.68	0.61	0.77	0.9	100.5	7.54	0.62	0.79	0.92	94.4	8.5	0.64	0.81	0.94	87.7	9.57	0.65	0.83	0.96
	4080	109.9	6.72	0.64	0.81	0.94	103.9	7.57	0.65	0.83	0.96	97.3	8.53	0.66	0.85	0.97	90.2	9.6	0.68	0.88	0.97
71°F	2720	106.8	6.69	0.44	0.57	0.69	101.3	7.54	0.44	0.58	0.71	95.5	8.51	0.44	0.59	0.73	88.8	9.58	0.45	0.6	0.75
	3400	112.2	6.74	0.44	0.59	0.74	106.2	7.59	0.44	0.6	0.76	99.7	8.56	0.45	0.62	0.78	92.7	9.63	0.45	0.64	0.81
	4080	116.1	6.77	0.45	0.62	0.79	109.9	7.64	0.45	0.63	0.81	103.1	8.6	0.46	0.65	0.83	95.6	9.67	0.46	0.67	0.86

## 8.5 TON STANDARD EFFICIENCY ZCA102S4M (1ST STAGE) - MSAV® (Multi-Stage Air Volume) SUPPLY AIR BLOWER

Entering Wet Bulb Temperature	Total Air Volume	Outdoor Air Temperature Entering Outdoor Coil																			
		65°F					75°F					85°F					95°F				
		Total Cool Cap.	Comp. Motor Input	Sensible To Total Ratio (S/T)			Total Cool Cap.	Comp. Motor Input	Sensible To Total Ratio (S/T)			Total Cool Cap.	Comp. Motor Input	Sensible To Total Ratio (S/T)			Total Cool Cap.	Comp. Motor Input	Sensible To Total Ratio (S/T)		
				Dry Bulb					Dry Bulb					Dry Bulb					Dry Bulb		
cfm	kBtuh	kW	75°F	80°F	85°F	kBtuh	kW	75°F	80°F	85°F	kBtuh	kW	75°F	80°F	85°F	kBtuh	kW	75°F	80°F	85°F	
63°F	1920	61.5	2.67	0.65	0.75	0.85	59.2	3.05	0.65	0.76	0.86	56.9	3.47	0.66	0.77	0.87	54.2	3.93	0.67	0.78	0.89
	2400	65.5	2.7	0.67	0.78	0.89	63.1	3.09	0.68	0.8	0.91	60.4	3.51	0.68	0.81	0.93	57.4	3.97	0.7	0.82	0.95
	2880	68.7	2.73	0.69	0.82	0.94	66	3.11	0.7	0.83	0.96	63.1	3.53	0.71	0.85	0.97	60	4	0.72	0.87	0.97
67°F	1920	64.9	2.7	0.52	0.62	0.71	62.6	3.08	0.52	0.63	0.72	59.9	3.5	0.52	0.63	0.73	57.1	3.96	0.53	0.64	0.74
	2400	69.1	2.73	0.53	0.64	0.75	66.3	3.12	0.53	0.65	0.76	63.3	3.53	0.53	0.65	0.77	60.4	4	0.54	0.67	0.79
	2880	71.9	2.75	0.53	0.66	0.78	69.2	3.14	0.54	0.67	0.8	66.2	3.56	0.54	0.68	0.81	62.9	4.03	0.55	0.69	0.83
71°F	1920	68.2	2.73	0.4	0.5	0.59	65.7	3.11	0.4	0.5	0.6	63	3.53	0.39	0.5	0.6	60.1	4	0.4	0.51	0.61
	2400	72.6	2.75	0.39	0.51	0.62	69.8	3.14	0.39	0.51	0.62	66.7	3.56	0.39	0.51	0.63	63.4	4.03	0.39	0.52	0.64
	2880	75.8	2.77	0.39	0.52	0.63	72.7	3.16	0.39	0.52	0.65	69.5	3.59	0.39	0.53	0.66	65.8	4.05	0.39	0.53	0.67

## 8.5 TON STANDARD EFFICIENCY ZCA102S4M (2ND STAGE) - MSAV® (Multi-Stage Air Volume) SUPPLY AIR BLOWER

Entering Wet Bulb Temperature	Total Air Volume	Outdoor Air Temperature Entering Outdoor Coil																			
		85°F					95°F					105°F					115°F				
		Total Cool Cap.	Comp. Motor Input	Sensible To Total Ratio (S/T)			Total Cool Cap.	Comp. Motor Input	Sensible To Total Ratio (S/T)			Total Cool Cap.	Comp. Motor Input	Sensible To Total Ratio (S/T)			Total Cool Cap.	Comp. Motor Input	Sensible To Total Ratio (S/T)		
				Dry Bulb					Dry Bulb					Dry Bulb					Dry Bulb		
cfm	kBtuh	kW	75°F	80°F	85°F	kBtuh	kW	75°F	80°F	85°F	kBtuh	kW	75°F	80°F	85°F	kBtuh	kW	75°F	80°F	85°F	
63°F	2720	95.7	6.57	0.75	0.87	0.97	90.6	7.42	0.77	0.89	0.98	85.2	8.37	0.78	0.91	0.99	79.2	9.44	0.8	0.94	0.98
	3400	100.3	6.62	0.8	0.92	0.98	94.8	7.47	0.81	0.94	0.98	89.2	8.42	0.83	0.96	0.98	83.1	9.5	0.85	0.98	0.98
	4080	104	6.66	0.83	0.96	0.98	98.6	7.51	0.85	0.97	0.98	92.9	8.47	0.87	0.98	0.98	87.1	9.56	0.9	0.97	0.98
67°F	2720	101.3	6.63	0.59	0.72	0.84	96	7.48	0.6	0.74	0.86	90.3	8.44	0.61	0.76	0.88	84	9.51	0.62	0.78	0.91
	3400	106.4	6.68	0.61	0.77	0.9	100.5	7.54	0.62	0.79	0.92	94.4	8.5	0.64	0.81	0.94	87.7	9.57	0.65	0.83	0.96
	4080	109.9	6.72	0.64	0.81	0.94	103.9	7.57	0.65	0.83	0.96	97.3	8.53	0.66	0.85	0.97	90.2	9.6	0.68	0.88	0.97
71°F	2720	106.8	6.69	0.44	0.57	0.69	101.3	7.54	0.44	0.58	0.71	95.5	8.51	0.44	0.59	0.73	88.8	9.58	0.45	0.6	0.75
	3400	112.2	6.74	0.44	0.59	0.74	106.2	7.59	0.44	0.6	0.76	99.7	8.56	0.45	0.62	0.78	92.7	9.63	0.45	0.64	0.81
	4080	116.1	6.77	0.45	0.62	0.79	109.9	7.64	0.45	0.63	0.81	103.1	8.6	0.46	0.65	0.83	95.6	9.67	0.46	0.67	0.86

# RATINGS

NOTE - For Temperatures and Capacities not shown in tables, see bulletin - Cooling Unit Rating Table Correction Factor Data in Miscellaneous Engineering Data section.

## 10 TON STANDARD EFFICIENCY ZCB120S4B (1ST STAGE) - CONSTANT AIR VOLUME

Entering Wet Bulb Temperature	Total Air Volume	Outdoor Air Temperature Entering Outdoor Coil																			
		65°F					75°F					85°F					95°F				
		Total Cool Cap.	Comp. Motor Input	Sensible To Total Ratio (S/T)			Total Cool Cap.	Comp. Motor Input	Sensible To Total Ratio (S/T)			Total Cool Cap.	Comp. Motor Input	Sensible To Total Ratio (S/T)			Total Cool Cap.	Comp. Motor Input	Sensible To Total Ratio (S/T)		
				Dry Bulb					Dry Bulb					Dry Bulb					Dry Bulb		
cfm	kBtuh	kW	75°F	80°F	85°F	kBtuh	kW	75°F	80°F	85°F	kBtuh	kW	75°F	80°F	85°F	kBtuh	kW	75°F	80°F	85°F	
63°F	3200	68.6	2.92	0.7	0.83	0.96	64.5	3.29	0.7	0.84	0.97	60	3.72	0.71	0.85	0.99	55.4	4.2	0.71	0.87	1
	3600	70.9	2.94	0.72	0.86	0.99	66.6	3.31	0.73	0.88	1	62.3	3.74	0.74	0.9	1	57.3	4.22	0.74	0.92	1
	4000	72.9	2.95	0.74	0.89	1	68.6	3.33	0.75	0.91	1	63.9	3.75	0.76	0.93	1	59.1	4.23	0.78	0.96	1
67°F	3200	73.6	2.95	0.56	0.67	0.79	69.4	3.32	0.55	0.68	0.81	64.8	3.76	0.55	0.68	0.82	60.1	4.24	0.54	0.69	0.83
	3600	76.1	2.97	0.57	0.7	0.83	71.6	3.34	0.57	0.7	0.84	67.1	3.77	0.56	0.72	0.86	62	4.25	0.56	0.72	0.88
	4000	78.1	2.98	0.58	0.72	0.86	73.7	3.36	0.58	0.73	0.88	68.7	3.78	0.58	0.74	0.9	63.9	4.27	0.58	0.76	0.92
71°F	3200	78.6	2.98	0.43	0.54	0.65	74.4	3.36	0.42	0.54	0.65	69.8	3.79	0.41	0.53	0.66	64.8	4.27	0.38	0.53	0.66
	3600	81.3	2.98	0.43	0.56	0.68	76.7	3.38	0.42	0.56	0.68	71.8	3.8	0.41	0.55	0.69	66.7	4.29	0.4	0.55	0.7
	4000	83.4	3	0.44	0.57	0.7	78.8	3.38	0.43	0.57	0.71	73.9	3.82	0.42	0.57	0.72	68.7	4.3	0.41	0.57	0.73

## 10 TON STANDARD EFFICIENCY ZCB120S4B (2ND STAGE) - CONSTANT AIR VOLUME

Entering Wet Bulb Temperature	Total Air Volume	Outdoor Air Temperature Entering Outdoor Coil																			
		85°F					95°F					105°F					115°F				
		Total Cool Cap.	Comp. Motor Input	Sensible To Total Ratio (S/T)			Total Cool Cap.	Comp. Motor Input	Sensible To Total Ratio (S/T)			Total Cool Cap.	Comp. Motor Input	Sensible To Total Ratio (S/T)			Total Cool Cap.	Comp. Motor Input	Sensible To Total Ratio (S/T)		
				Dry Bulb					Dry Bulb					Dry Bulb					Dry Bulb		
cfm	kBtuh	kW	75°F	80°F	85°F	kBtuh	kW	75°F	80°F	85°F	kBtuh	kW	75°F	80°F	85°F	kBtuh	kW	75°F	80°F	85°F	
63°F	3200	120.1	7.36	0.71	0.85	0.99	110.9	8.31	0.71	0.87	1	101.3	9.36	0.72	0.9	1	91.2	10.53	0.74	0.93	1
	3600	124.4	7.41	0.74	0.9	1	114.8	8.34	0.75	0.92	1	104.9	9.39	0.76	0.95	1	94.5	10.56	0.78	0.98	1
	4000	128	7.43	0.76	0.94	1	118.3	8.37	0.78	0.96	1	108.2	9.43	0.8	0.99	1	98	10.59	0.82	1	1
67°F	3200	129.6	7.43	0.54	0.68	0.82	120.1	8.38	0.54	0.69	0.83	110.3	9.44	0.53	0.7	0.86	99.7	10.61	0.54	0.71	0.89
	3600	134.1	7.47	0.56	0.71	0.86	124.2	8.42	0.56	0.72	0.88	114	9.47	0.56	0.74	0.91	103.1	10.65	0.56	0.75	0.94
	4000	137.6	7.49	0.58	0.74	0.9	127.6	8.45	0.58	0.75	0.92	117.3	9.5	0.59	0.77	0.95	106.2	10.67	0.59	0.79	0.99
71°F	3200	139.7	7.5	0.41	0.53	0.66	129.9	8.46	0.39	0.53	0.67	119.6	9.52	0.37	0.52	0.67	108.7	10.69	0.36	0.53	0.69
	3600	143.8	7.53	0.41	0.55	0.69	133.7	8.48	0.4	0.55	0.7	123	9.53	0.39	0.55	0.71	112.1	10.72	0.38	0.56	0.73
	4000	147.6	7.55	0.42	0.57	0.72	137.2	8.5	0.41	0.57	0.73	126.4	9.57	0.4	0.58	0.75	115	10.75	0.39	0.58	0.77

## 10 TON STANDARD EFFICIENCY ZCA120S4M (1ST STAGE) - MSAV® (Multi-Stage Air Volume) SUPPLY AIR BLOWER

Entering Wet Bulb Temperature	Total Air Volume	Outdoor Air Temperature Entering Outdoor Coil																			
		65°F					75°F					85°F					95°F				
		Total Cool Cap.	Comp. Motor Input	Sensible To Total Ratio (S/T)			Total Cool Cap.	Comp. Motor Input	Sensible To Total Ratio (S/T)			Total Cool Cap.	Comp. Motor Input	Sensible To Total Ratio (S/T)			Total Cool Cap.	Comp. Motor Input	Sensible To Total Ratio (S/T)		
				Dry Bulb					Dry Bulb					Dry Bulb					Dry Bulb		
cfm	kBtuh	kW	75°F	80°F	85°F	kBtuh	kW	75°F	80°F	85°F	kBtuh	kW	75°F	80°F	85°F	kBtuh	kW	75°F	80°F	85°F	
63°F	2240	56.7	2.72	0.62	0.73	0.84	53	3.05	0.62	0.73	0.85	49	3.43	0.61	0.73	0.86	44.7	3.87	0.6	0.74	0.88
	2800	61.6	2.73	0.66	0.78	0.9	57.5	3.06	0.66	0.79	0.92	53.2	3.45	0.65	0.8	0.93	48.5	3.9	0.65	0.81	0.96
	3360	65.1	2.74	0.69	0.83	0.96	60.8	3.08	0.7	0.84	0.98	56.2	3.47	0.7	0.85	1	51.5	3.92	0.7	0.87	1
67°F	2240	61.1	2.73	0.5	0.6	0.7	57.2	3.06	0.49	0.6	0.7	53.1	3.45	0.48	0.59	0.7	48.7	3.9	0.46	0.58	0.71
	2800	66.1	2.74	0.53	0.64	0.75	61.9	3.09	0.51	0.64	0.75	57.5	3.48	0.51	0.63	0.76	52.7	3.93	0.49	0.63	0.77
	3360	69.8	2.75	0.55	0.67	0.8	65.4	3.11	0.54	0.67	0.8	60.7	3.5	0.53	0.68	0.82	55.7	3.95	0.52	0.68	0.84
71°F	2240	65.5	2.73	0.4	0.49	0.58	61.4	3.08	0.38	0.48	0.58	57.2	3.48	0.36	0.47	0.57	52.7	3.93	0.34	0.45	0.56
	2800	70.6	2.76	0.41	0.51	0.62	66.3	3.1	0.39	0.51	0.61	61.7	3.5	0.38	0.5	0.61	56.8	3.96	0.35	0.49	0.61
	3360	74.5	2.76	0.42	0.54	0.65	69.8	3.12	0.4	0.53	0.65	65	3.52	0.39	0.52	0.66	59.9	3.98	0.37	0.52	0.66

## 10 TON STANDARD EFFICIENCY ZCA120S4M (2ND STAGE) - MSAV® (Multi-Stage Air Volume) SUPPLY AIR BLOWER

Entering Wet Bulb Temperature	Total Air Volume	Outdoor Air Temperature Entering Outdoor Coil																			
		85°F					95°F					105°F					115°F				
		Total Cool Cap.	Comp. Motor Input	Sensible To Total Ratio (S/T)			Total Cool Cap.	Comp. Motor Input	Sensible To Total Ratio (S/T)			Total Cool Cap.	Comp. Motor Input	Sensible To Total Ratio (S/T)			Total Cool Cap.	Comp. Motor Input	Sensible To Total Ratio (S/T)		
				Dry Bulb					Dry Bulb					Dry Bulb					Dry Bulb		
cfm	kBtuh	kW	75°F	80°F	85°F	kBtuh	kW	75°F	80°F	85°F	kBtuh	kW	75°F	80°F	85°F	kBtuh	kW	75°F	80°F	85°F	
63°F	3200	114	7.38	0.68	0.83	0.98	104.2	8.32	0.68	0.85	1	93.9	9.38	0.68	0.87	1	83.2	10.57	0.69	0.91	1
	4000	121	7.42	0.73	0.92	1	111.1	8.38	0.74	0.94	1	100.5	9.44	0.76	0.97	1	89.4	10.64	0.78	1	1
	4800	126.9	7.46	0.79	0.99	1	116.4	8.42	0.81	1	1	106.5	9.5	0.83	1	1	96	10.71	0.86	1	1
67°F	3200	123.1	7.43	0.52	0.66	0.79	113	8.39	0.51	0.66	0.81	102.5	9.46	0.5	0.67	0.83	91.5	10.66	0.49	0.67	0.87
	4000	130.6	7.48	0.55	0.71	0.88	120	8.44	0.55	0.72	0.9	108.8	9.52	0.55	0.74	0.93	97	10.73	0.55	0.76	0.98
	4800	136	7.51	0.59	0.77	0.95	124.9	8.48	0.59	0.78	0.98	113.3	9.56	0.59	0.81	1	101.2	10.77	0.6	0.84	1
71°F	3200	131.9	7.49	0.38	0.51	0.64	121.6	8.45	0.36	0.5	0.64	110.7	9.53	0.34	0.5	0.65	99.4	10.75	0.32	0.49	0.65
	4000	139.7	7.54	0.4	0.55	0.69	128.7	8.5	0.39	0.55	0.7	117.5	9.6	0.37	0.55	0.72	105.4	10.82	0.35	0.55	0.74
	4800	145.4	7.58	0.42	0.58	0.75	134	8.56	0.41	0.59	0.76	122.3	9.65	0.39	0.59	0.78	109.7	10.88	0.38	0.6	0.82

# RATINGS

NOTE – For Temperatures and Capacities not shown in tables, see bulletin – Cooling Unit Rating Table Correction Factor Data in Miscellaneous Engineering Data section.

## 12.5 TON STANDARD EFFICIENCY ZCB150S4B (1ST STAGE) - CONSTANT AIR VOLUME

Entering Wet Bulb Temperature	Total Air Volume	Outdoor Air Temperature Entering Outdoor Coil																			
		65°F					75°F					85°F					95°F				
		Total Cool Cap.	Comp. Motor Input	Sensible To Total Ratio (S/T)			Total Cool Cap.	Comp. Motor Input	Sensible To Total Ratio (S/T)			Total Cool Cap.	Comp. Motor Input	Sensible To Total Ratio (S/T)			Total Cool Cap.	Comp. Motor Input	Sensible To Total Ratio (S/T)		
				Dry Bulb					Dry Bulb					Dry Bulb					Dry Bulb		
cfm	kBtuh	kW	75°F	80°F	85°F	kBtuh	kW	75°F	80°F	85°F	kBtuh	kW	75°F	80°F	85°F	kBtuh	kW	75°F	80°F	85°F	
63°F	4400	78.3	3.14	0.73	0.87	0.99	74	3.48	0.73	0.88	1	69.4	3.85	0.74	0.9	1	64.5	4.26	0.75	0.92	1
	4800	80.1	3.12	0.75	0.89	1	75.6	3.48	0.75	0.91	1	70.9	3.85	0.76	0.93	1	66	4.26	0.77	0.95	1
	5200	81.6	3.13	0.76	0.92	1	77.1	3.47	0.77	0.94	1	72.3	3.85	0.78	0.96	1	67.4	4.26	0.8	0.98	1
67°F	4400	83.6	3.13	0.58	0.7	0.83	79.2	3.48	0.57	0.71	0.85	74.4	3.84	0.57	0.72	0.86	69.3	4.25	0.57	0.72	0.88
	4800	85.5	3.13	0.59	0.72	0.86	80.9	3.47	0.58	0.73	0.87	75.9	3.84	0.6	0.74	0.89	71	4.25	0.58	0.75	0.91
	5200	87.1	3.12	0.6	0.74	0.89	82.4	3.47	0.6	0.75	0.9	77.4	3.84	0.59	0.76	0.92	72.3	4.26	0.6	0.78	0.94
71°F	4400	89.2	3.12	0.44	0.56	0.68	84.7	3.47	0.43	0.56	0.69	79.8	3.83	0.41	0.56	0.69	74.8	4.25	0.41	0.56	0.7
	4800	90.9	3.12	0.45	0.57	0.7	86.3	3.46	0.43	0.57	0.71	81.3	3.84	0.42	0.58	0.72	76.2	4.24	0.41	0.57	0.72
	5200	92.4	3.11	0.44	0.58	0.72	87.5	3.47	0.44	0.59	0.73	82.6	3.83	0.43	0.59	0.74	77.3	4.24	0.42	0.59	0.75

## 12.5 TON STANDARD EFFICIENCY ZCB150S4B (2ND STAGE) - CONSTANT AIR VOLUME

Entering Wet Bulb Temperature	Total Air Volume	Outdoor Air Temperature Entering Outdoor Coil																			
		85°F					95°F					105°F					115°F				
		Total Cool Cap.	Comp. Motor Input	Sensible To Total Ratio (S/T)			Total Cool Cap.	Comp. Motor Input	Sensible To Total Ratio (S/T)			Total Cool Cap.	Comp. Motor Input	Sensible To Total Ratio (S/T)			Total Cool Cap.	Comp. Motor Input	Sensible To Total Ratio (S/T)		
				Dry Bulb					Dry Bulb					Dry Bulb					Dry Bulb		
cfm	kBtuh	kW	75°F	80°F	85°F	kBtuh	kW	75°F	80°F	85°F	kBtuh	kW	75°F	80°F	85°F	kBtuh	kW	75°F	80°F	85°F	
63°F	4400	150.2	9.13	0.74	0.9	1	138.4	10.17	0.76	0.93	1	126.4	11.35	0.78	0.96	1	113.9	12.71	0.8	0.99	1
	4800	153.4	9.17	0.77	0.94	1	141.5	10.21	0.78	0.96	1	129.2	11.39	0.81	0.99	1	117	12.74	0.84	1	1
	5200	156.2	9.2	0.79	0.97	1	144.3	10.24	0.81	0.99	1	132.4	11.43	0.84	1	1	120.5	12.79	0.87	1	1
67°F	4400	160.4	9.25	0.57	0.72	0.87	148.4	10.29	0.57	0.74	0.9	135.9	11.47	0.57	0.75	0.93	122.6	12.82	0.58	0.78	0.97
	4800	163.6	9.28	0.59	0.75	0.9	151.3	10.33	0.59	0.76	0.93	138.7	11.52	0.6	0.78	0.97	124.9	12.85	0.61	0.81	1
	5200	166.4	9.32	0.6	0.77	0.93	153.8	10.36	0.6	0.79	0.97	140.6	11.53	0.62	0.81	0.99	126.9	12.88	0.63	0.85	1
71°F	4400	171.6	9.38	0.42	0.57	0.7	159.1	10.42	0.41	0.56	0.72	146	11.61	0.4	0.57	0.73	132.2	12.95	0.39	0.58	0.76
	4800	174.7	9.42	0.43	0.58	0.73	161.8	10.46	0.42	0.58	0.74	148.4	11.65	0.41	0.59	0.76	134.1	12.98	0.4	0.6	0.79
	5200	177.2	9.45	0.43	0.59	0.75	164.1	10.5	0.43	0.6	0.77	150.4	11.67	0.42	0.61	0.79	136	13.01	0.41	0.62	0.83

## 12.5 TON STANDARD EFFICIENCY ZCA150S4M (1ST STAGE) - MSAV® (Multi-Stage Air Volume) SUPPLY AIR BLOWER

Entering Wet Bulb Temperature	Total Air Volume	Outdoor Air Temperature Entering Outdoor Coil																			
		65°F					75°F					85°F					95°F				
		Total Cool Cap.	Comp. Motor Input	Sensible To Total Ratio (S/T)			Total Cool Cap.	Comp. Motor Input	Sensible To Total Ratio (S/T)			Total Cool Cap.	Comp. Motor Input	Sensible To Total Ratio (S/T)			Total Cool Cap.	Comp. Motor Input	Sensible To Total Ratio (S/T)		
				Dry Bulb					Dry Bulb					Dry Bulb					Dry Bulb		
cfm	kBtuh	kW	75°F	80°F	85°F	kBtuh	kW	75°F	80°F	85°F	kBtuh	kW	75°F	80°F	85°F	kBtuh	kW	75°F	80°F	85°F	
63°F	2560	67.1	3.22	0.63	0.73	0.84	62.6	3.61	0.62	0.73	0.84	58	4.05	0.62	0.74	0.86	53.1	4.55	0.61	0.74	0.87
	3200	72.7	3.25	0.66	0.78	0.9	68	3.65	0.66	0.79	0.91	62.9	4.09	0.66	0.8	0.93	57.8	4.59	0.66	0.81	0.96
	3840	76.9	3.28	0.69	0.83	0.95	71.8	3.68	0.7	0.84	0.97	66.6	4.12	0.7	0.85	1	61	4.62	0.7	0.87	1
67°F	2560	72.2	3.25	0.51	0.61	0.7	67.7	3.64	0.5	0.6	0.7	62.8	4.09	0.49	0.59	0.7	57.8	4.59	0.47	0.59	0.71
	3200	77.9	3.29	0.53	0.64	0.75	73	3.69	0.52	0.64	0.76	67.9	4.13	0.52	0.64	0.76	62.3	4.64	0.5	0.64	0.77
	3840	82.2	3.32	0.55	0.67	0.79	76.9	3.72	0.55	0.68	0.8	71.5	4.17	0.54	0.68	0.82	65.7	4.67	0.53	0.68	0.84
71°F	2560	77.7	3.28	0.4	0.49	0.59	73	3.68	0.39	0.48	0.58	68	4.13	0.37	0.48	0.58	62.8	4.64	0.35	0.46	0.57
	3200	83.3	3.32	0.41	0.52	0.62	78.3	3.73	0.4	0.51	0.62	73	4.18	0.39	0.51	0.62	67.3	4.69	0.37	0.5	0.62
	3840	87.6	3.36	0.42	0.54	0.65	82	3.77	0.42	0.53	0.65	76.4	4.21	0.4	0.53	0.66	70.4	4.72	0.38	0.53	0.67

## 12.5 TON STANDARD EFFICIENCY ZCA150S4M (2ND STAGE) - MSAV® (Multi-Stage Air Volume) SUPPLY AIR BLOWER

Entering Wet Bulb Temperature	Total Air Volume	Outdoor Air Temperature Entering Outdoor Coil																			
		85°F					95°F					105°F					115°F				
		Total Cool Cap.	Comp. Motor Input	Sensible To Total Ratio (S/T)			Total Cool Cap.	Comp. Motor Input	Sensible To Total Ratio (S/T)			Total Cool Cap.	Comp. Motor Input	Sensible To Total Ratio (S/T)			Total Cool Cap.	Comp. Motor Input	Sensible To Total Ratio (S/T)		
				Dry Bulb					Dry Bulb					Dry Bulb					Dry Bulb		
cfm	kBtuh	kW	75°F	80°F	85°F	kBtuh	kW	75°F	80°F	85°F	kBtuh	kW	75°F	80°F	85°F	kBtuh	kW	75°F	80°F	85°F	
63°F	3800	138.4	8.53	0.7	0.85	1	126.7	9.57	0.7	0.87	1	114.7	10.76	0.71	0.9	1	102.2	12.13	0.73	0.94	1
	4400	143.8	8.58	0.74	0.91	1	132	9.62	0.75	0.93	1	119.5	10.81	0.77	0.97	1	106.6	12.19	0.79	1	1
	5000	148.6	8.63	0.77	0.96	1	136.3	9.67	0.79	0.99	1	124	10.86	0.82	1	1	111.8	12.24	0.85	1	1
67°F	3800	148.6	8.63	0.54	0.68	0.82	136.8	9.67	0.54	0.69	0.84	124.2	10.86	0.53	0.7	0.86	111.2	12.23	0.53	0.71	0.9
	4400	154.2	8.68	0.56	0.72	0.87	142	9.72	0.56	0.73	0.89	129	10.92	0.56	0.74	0.93	115.4	12.29	0.56	0.77	0.97
	5000	158.9	8.73	0.58	0.75	0.92	146.1	9.77	0.59	0.77	0.95	132.8	10.96	0.59	0.79	0.99	118.9	12.33	0.6	0.82	1
71°F	3800	159.6	8.73	0.4	0.53	0.66	147.1	9.78	0.38	0.53	0.67	134.1	10.97	0.37	0.52	0.68	120.5	12.34	0.35	0.52	0.69
	4400	164.9	8.79	0.41	0.56	0.7	152.1	9.83	0.4	0.55	0.71	138.6	11.03	0.38	0.55	0.72	124.4	12.39	0.37	0.56	0.75
	5000	169.3	8.83	0.42	0.58	0.73	156	9.88	0.41	0.58	0.75	142.2	11.07	0.4	0.59	0.77	127.9	12.44	0.39	0.6	0.8

## BLOWER DATA

### 092S STANDARD EFFICIENCY BELT DRIVE BLOWER – BASE UNIT

BLOWER TABLE INCLUDES RESISTANCE FOR BASE UNIT ONLY (NO HEAT SECTION) WITH DRY INDOOR COIL AND AIR FILTERS IN PLACE. FOR ALL UNITS ADD:

- 1 – Wet indoor coil air resistance of selected unit.
- 2 – Any factory installed options air resistance (heat section, economizer, etc.)
- 3 – Any field installed accessories air resistance (duct resistance, diffuser, etc.)

Then determine from blower table blower motor output required.

See page 24 for blower motors and drives.

See page 24 for wet coil and option/accessory air resistance data.

**MINIMUM AIR VOLUME REQUIRED FOR USE WITH OPTIONAL ELECTRIC HEAT (Maximum Static Pressure - 2.0 in. w.g.):**

7.5 kW, 15 kW, 22.5 kW - 2065 cfm

30 kW - 2250 cfm

45 kW - 2625 cfm

Total Air Volume cfm	Total Static Pressure – in. w.g.																										
	0.2		0.4		0.6		0.8		1.0		1.2		1.4		1.6		1.8		2		2.2		2.4		2.6		
	RPM	BHP	RPM	BHP	RPM	BHP	RPM	BHP	RPM	BHP	RPM	BHP	RPM	BHP	RPM	BHP	RPM	BHP	RPM	BHP	RPM	BHP	RPM	BHP	RPM	BHP	RPM
1750	498	0.08	565	0.25	633	0.50	701	0.71	768	0.87	830	0.99	890	1.08	946	1.16	998	1.27	1049	1.41	1098	1.58	---	---	---	---	
2000	512	0.12	578	0.37	645	0.60	713	0.81	780	0.97	842	1.10	901	1.19	955	1.28	1007	1.40	1057	1.56	1105	1.74	1153	1.94	1201	2.16	
2250	527	0.24	592	0.49	659	0.72	727	0.92	793	1.08	855	1.21	913	1.32	966	1.42	1017	1.55	1066	1.72	1114	1.92	1162	2.13	1210	2.35	
2500	543	0.37	608	0.61	675	0.84	743	1.04	809	1.21	869	1.35	926	1.45	978	1.57	1028	1.72	1076	1.90	1124	2.11	1171	2.33	1221	2.57	
2750	560	0.51	625	0.75	693	0.98	761	1.18	826	1.35	885	1.49	939	1.60	990	1.73	1039	1.90	1087	2.10	1135	2.32	1183	2.55	1232	2.80	
3000	579	0.66	645	0.90	713	1.13	781	1.34	844	1.51	901	1.65	954	1.77	1004	1.92	1052	2.11	1100	2.32	1147	2.56	1195	2.80	1245	3.05	
3250	600	0.82	666	1.06	735	1.30	803	1.51	864	1.69	918	1.82	969	1.95	1018	2.12	1066	2.34	1113	2.57	1161	2.81	1209	3.06	1259	3.31	
3500	622	0.98	690	1.24	760	1.49	826	1.70	883	1.87	936	2.01	985	2.16	1033	2.35	1081	2.59	1128	2.84	1176	3.09	1224	3.34	1275	3.60	
3750	646	1.17	716	1.45	786	1.70	849	1.91	903	2.07	953	2.21	1002	2.38	1049	2.61	1097	2.87	1144	3.12	1192	3.38	1241	3.64	1292	3.91	
4000	674	1.38	746	1.68	814	1.93	872	2.12	923	2.28	971	2.43	1019	2.64	1067	2.90	1114	3.17	1161	3.43	1209	3.69	1259	3.96	1311	4.24	
4250	705	1.63	777	1.94	841	2.17	894	2.34	943	2.50	990	2.69	1038	2.93	1085	3.21	1132	3.49	1179	3.76	1228	4.03	1279	4.31	1332	4.60	

## BLOWER DATA

### 102S STANDARD EFFICIENCY BELT DRIVE BLOWER – BASE UNIT

**BLOWER TABLE INCLUDES RESISTANCE FOR BASE UNIT ONLY (NO HEAT SECTION) WITH DRY INDOOR COIL AND AIR FILTERS IN PLACE. FOR ALL UNITS ADD:**

- 1 – Wet indoor coil air resistance of selected unit.
- 2 – Any factory installed options air resistance (heat section, economizer, etc.)
- 3 – Any field installed accessories air resistance (duct resistance, diffuser, etc.)

Then determine from blower table blower motor output required.

See page 24 for blower motors and drives.

See page 24 for wet coil and option/accessory air resistance data.

**MINIMUM AIR VOLUME REQUIRED FOR USE WITH OPTIONAL ELECTRIC HEAT (Maximum Static Pressure - 2.0 in. w.g.):**

- 7.5 kW, 15 kW, 22.5 kW - 2065 cfm
- 30 kW - 2250 cfm
- 45 kW - 2625 cfm

Total Air Volume cfm	Total Static Pressure – in. w.g.																									
	0.2		0.4		0.6		0.8		1.0		1.2		1.4		1.6		1.8		2.0		2.2		2.4		2.6	
	RPM	BHP	RPM	BHP	RPM	BHP	RPM	BHP	RPM	BHP	RPM	BHP	RPM	BHP	RPM	BHP	RPM	BHP	RPM	BHP	RPM	BHP	RPM	BHP	RPM	BHP
1750	494	0.11	562	0.34	632	0.56	702	0.74	771	0.85	838	0.96	902	1.07	961	1.19	---	---	---	---	---	---	---	---	---	---
2000	514	0.26	581	0.49	650	0.70	719	0.87	786	0.98	852	1.09	915	1.20	972	1.32	1026	1.47	1076	1.65	---	---	---	---	---	---
2250	533	0.41	599	0.62	667	0.82	735	0.99	802	1.10	866	1.21	928	1.33	984	1.46	1037	1.63	1085	1.81	1132	2.01	1178	2.21	1226	2.43
2500	553	0.55	619	0.76	685	0.95	753	1.10	818	1.22	881	1.34	942	1.47	997	1.62	1048	1.80	1096	1.99	1142	2.20	1188	2.41	1237	2.64
2750	573	0.70	638	0.90	705	1.08	771	1.22	835	1.35	897	1.49	957	1.63	1011	1.80	1061	1.99	1108	2.19	1154	2.41	1200	2.63	1249	2.87
3000	594	0.85	659	1.05	725	1.22	791	1.36	853	1.50	915	1.65	973	1.81	1026	1.99	1075	2.20	1121	2.42	1167	2.64	1213	2.87	1262	3.12
3250	617	1.01	682	1.20	747	1.37	812	1.52	873	1.67	934	1.83	990	2.01	1042	2.21	1089	2.43	1135	2.66	1181	2.90	1228	3.13	1277	3.38
3500	640	1.17	706	1.36	771	1.53	834	1.70	895	1.86	954	2.03	1008	2.23	1058	2.46	1105	2.69	1150	2.93	1196	3.17	1243	3.41	1293	3.65
3750	665	1.34	731	1.54	796	1.72	857	1.89	917	2.07	975	2.26	1027	2.48	1076	2.72	1121	2.97	1166	3.22	1212	3.46	1261	3.71	1311	3.96
4000	692	1.54	758	1.75	822	1.93	882	2.11	940	2.30	996	2.51	1047	2.76	1094	3.02	1139	3.27	1184	3.52	1230	3.77	1280	4.03	1330	4.29
4250	722	1.76	787	1.97	849	2.15	908	2.35	965	2.56	1018	2.79	1067	3.06	1113	3.33	1157	3.59	1202	3.85	1250	4.11	1300	4.38	1352	4.65

## BLOWER DATA

### 120S4M STANDARD EFFICIENCY BELT DRIVE BLOWER – BASE UNIT

**BLOWER TABLE INCLUDES RESISTANCE FOR BASE UNIT ONLY (NO HEAT SECTION) WITH DRY INDOOR COIL AND AIR FILTERS IN PLACE. FOR ALL UNITS ADD:**

- 1 – Wet indoor coil air resistance of selected unit.
- 2 – Any factory installed options air resistance (heat section, economizer, etc.)
- 3 – Any field installed accessories air resistance (duct resistance, diffuser, etc.)

Then determine from blower table blower motor output required.

See page 24 for blower motors and drives.

See page 24 for wet coil and option/accessory air resistance data.

### MINIMUM AIR VOLUME REQUIRED FOR USE WITH OPTIONAL ELECTRIC HEAT (Maximum Static Pressure - 2.0 in. w.g.)

15 kW, 22.5 kW- 2065 cfm

30 kW - 2250 cfm

45 kW - 2625 cfm

60 kW - 3500 cfm

Total Air Volume cfm	Total Static Pressure – in. w.g.																									
	0.2		0.4		0.6		0.8		1.0		1.2		1.4		1.6		1.8		2		2.2		2.4		2.6	
	RPM	BHP	RPM	BHP	RPM	BHP	RPM	BHP	RPM	BHP	RPM	BHP	RPM	BHP	RPM	BHP	RPM	BHP	RPM	BHP	RPM	BHP	RPM	BHP	RPM	BHP
2000	535	0.28	596	0.49	660	0.69	724	0.87	788	1.00	851	1.11	913	1.23	971	1.37	1025	1.52	1076	1.69	1124	1.86	---	---	---	---
2250	552	0.43	613	0.63	675	0.81	738	0.98	802	1.11	864	1.22	925	1.36	982	1.51	1036	1.68	1085	1.85	1133	2.04	1180	2.23	1228	2.44
2500	570	0.57	630	0.76	692	0.94	754	1.10	817	1.22	879	1.35	939	1.51	995	1.67	1047	1.85	1096	2.04	1143	2.23	1190	2.43	1239	2.65
2750	589	0.72	648	0.91	709	1.08	772	1.22	833	1.36	894	1.50	954	1.67	1009	1.85	1059	2.04	1108	2.24	1154	2.44	1202	2.65	1251	2.87
3000	608	0.87	668	1.05	729	1.22	791	1.37	852	1.51	912	1.67	970	1.85	1023	2.05	1073	2.25	1120	2.46	1167	2.67	1215	2.89	1265	3.11
3250	629	1.03	688	1.21	749	1.37	811	1.52	871	1.68	930	1.86	987	2.06	1039	2.27	1088	2.49	1134	2.70	1181	2.92	1229	3.14	1279	3.37
3500	651	1.20	710	1.38	772	1.54	833	1.70	892	1.88	950	2.07	1004	2.28	1055	2.51	1103	2.74	1150	2.96	1196	3.19	1245	3.42	1295	3.65
3750	674	1.36	734	1.56	796	1.73	856	1.90	914	2.10	970	2.30	1023	2.53	1072	2.78	1120	3.02	1166	3.25	1213	3.47	1262	3.71	1313	3.95
4000	699	1.55	761	1.76	822	1.94	880	2.12	936	2.33	991	2.56	1042	2.81	1090	3.07	1137	3.31	1183	3.55	1231	3.78	1281	4.03	1333	4.28
4250	726	1.77	789	1.98	849	2.16	904	2.37	959	2.59	1012	2.84	1062	3.11	1109	3.38	1156	3.63	1202	3.87	1251	4.11	1302	4.37	1354	4.63
4500	756	2.01	818	2.22	875	2.41	929	2.63	983	2.88	1034	3.15	1082	3.44	1129	3.71	1175	3.96	1222	4.21	1271	4.46	1323	4.72	1376	5.00
4750	788	2.27	848	2.47	902	2.68	955	2.92	1006	3.20	1056	3.50	1104	3.79	1150	4.06	1196	4.32	1243	4.57	1293	4.83	1345	5.09	1399	5.37
5000	822	2.54	878	2.75	929	2.98	980	3.25	1031	3.56	1079	3.87	1126	4.16	1172	4.44	1218	4.70	1266	4.95	1315	5.20	1367	5.47	1421	5.74

## BLOWER DATA

### 120S4B AND 150S STANDARD EFFICIENCY BELT DRIVE BLOWER – BASE UNIT

**BLOWER TABLE INCLUDES RESISTANCE FOR BASE UNIT ONLY (NO HEAT SECTION) WITH DRY INDOOR COIL AND AIR FILTERS IN PLACE. FOR ALL UNITS ADD:**

- 1 – Wet indoor coil air resistance of selected unit.
- 2 – Any factory installed options air resistance (heat section, economizer, etc.)
- 3 – Any field installed accessories air resistance (duct resistance, diffuser, etc.)

Then determine from blower table blower motor output required.

See page 24 for blower motors and drives.

See page 24 for wet coil and option/accessory air resistance data.

### MINIMUM AIR VOLUME REQUIRED FOR USE WITH OPTIONAL ELECTRIC HEAT (Maximum Static Pressure - 2.0 in. w.g.)

15 kW, 22.5 kW- 2065 cfm

30 kW - 2250 cfm

45 kW - 2625 cfm

60 kW - 3500 cfm

Total Air Volume cfm	Total Static Pressure – in. w.g.																										
	0.2		0.4		0.6		0.8		1.0		1.2		1.4		1.6		1.8		2.0		2.2		2.4		2.6		
	RPM	BHP	RPM	BHP	RPM	BHP	RPM	BHP	RPM	BHP	RPM	BHP	RPM	BHP	RPM	BHP	RPM	BHP	RPM	BHP	RPM	BHP	RPM	BHP	RPM	BHP	RPM
2000	542	0.43	602	0.60	664	0.75	732	0.89	802	1.02	869	1.15	927	1.27	979	1.41	1029	1.57	1079	1.75	1129	1.95	1179	2.15	1230	2.37	
2250	560	0.55	619	0.71	681	0.86	748	1.00	817	1.14	882	1.27	939	1.41	991	1.57	1041	1.74	1090	1.93	1140	2.13	1190	2.35	1241	2.57	
2500	579	0.68	637	0.83	699	0.98	766	1.12	834	1.26	897	1.41	953	1.57	1005	1.74	1054	1.92	1103	2.12	1152	2.33	1202	2.55	1254	2.79	
2750	599	0.81	657	0.97	719	1.11	785	1.25	851	1.41	913	1.57	968	1.74	1020	1.93	1068	2.13	1116	2.34	1165	2.56	1215	2.78	1268	3.01	
3000	620	0.95	678	1.11	741	1.25	806	1.40	870	1.58	930	1.75	985	1.94	1036	2.14	1084	2.36	1131	2.58	1180	2.80	1230	3.02	1283	3.26	
3250	643	1.10	701	1.26	764	1.41	828	1.57	891	1.76	950	1.95	1003	2.16	1053	2.38	1100	2.61	1148	2.83	1196	3.06	1246	3.29	1299	3.52	
3500	667	1.26	726	1.43	788	1.58	851	1.77	913	1.97	970	2.17	1023	2.41	1071	2.65	1118	2.88	1165	3.11	1213	3.33	1264	3.57	1317	3.81	
3750	693	1.44	752	1.61	813	1.78	876	1.98	936	2.20	992	2.43	1043	2.68	1091	2.93	1137	3.17	1183	3.40	1232	3.64	1284	3.88	1338	4.13	
4000	720	1.65	779	1.82	840	2.00	902	2.22	961	2.46	1015	2.71	1064	2.98	1111	3.24	1156	3.48	1203	3.72	1253	3.96	1305	4.22	1359	4.48	
4250	748	1.86	807	2.04	868	2.24	929	2.48	986	2.75	1038	3.02	1086	3.30	1132	3.57	1177	3.81	1224	4.05	1274	4.31	1327	4.57	1382	4.85	
4500	778	2.09	837	2.28	898	2.51	957	2.78	1012	3.07	1062	3.37	1108	3.65	1154	3.92	1199	4.17	1247	4.41	1297	4.67	1350	4.94	1405	5.22	
4750	809	2.34	868	2.56	929	2.82	986	3.12	1038	3.43	1087	3.74	1132	4.03	1177	4.29	1223	4.54	1270	4.79	1321	5.04	1374	5.31	1428	5.58	
5000	841	2.62	901	2.87	960	3.17	1015	3.50	1065	3.83	1112	4.14	1157	4.43	1201	4.69	1247	4.94	1295	5.18	1345	5.42	1398	5.68	---	---	
5250	875	2.93	935	3.23	992	3.56	1044	3.91	1092	4.26	1138	4.57	1182	4.85	1226	5.10	1272	5.34	1320	5.57	---	---	---	---	---	---	
5500	911	3.30	969	3.63	1024	4.00	1074	4.37	1120	4.71	1165	5.02	1208	5.29	1253	5.53	---	---	---	---	---	---	---	---	---	---	
5750	948	3.71	1004	4.08	1056	4.48	1104	4.85	1148	5.19	1192	5.49	1235	5.74	---	---	---	---	---	---	---	---	---	---	---	---	
6000	985	4.18	1039	4.59	1088	5.00	1134	5.37	1177	5.69	---	---	---	---	---	---	---	---	---	---	---	---	---	---	---	---	
6250	1022	4.70	1073	5.14	1120	5.54	---	---	---	---	---	---	---	---	---	---	---	---	---	---	---	---	---	---	---	---	

## BLOWER DATA

### FACTORY INSTALLED BELT DRIVE KIT SPECIFICATIONS

Nominal hp	Maximum hp	Drive Kit Number	RPM Range
2	2.3	1	590 - 890
2	2.3	2	800 - 1105
2	2.3	3	795 - 1195
3	3.45	4	730 - 970
3	3.45	5	940 - 1200
3	3.45	6	1015 - 1300
5	5.75	10	900 - 1135
5	5.75	11	1040 - 1315
5	5.75	12	1125 - 1425

NOTE - Using total air volume and system static pressure requirements determine from blower performance tables rpm and motor output required. Maximum usable output of motors furnished are shown. In Canada, nominal motor output is also maximum usable motor output. If motors of comparable output are used, be sure to keep within the service factor limitations outlined on the motor nameplate.

NOTE - Units equipped with MSAV® (Multi-Stage Air Volume) option are limited to a motor service factor of 1.0.

### POWER EXHAUST FAN PERFORMANCE

Return Air System Static Pressure	Air Volume Exhausted
in. w.g.	cfm
0	3575
0.05	3405
0.10	3550
0.15	3245
0.20	3115
0.25	3020
0.30	2900
0.35	2785

### FACTORY INSTALLED OPTIONS/FIELD INSTALLED ACCESSORY AIR RESISTANCE - in. w.g.

Air Volume cfm	Wet Indoor Coil			Electric Heat	Economizer	Filters	
	092	102, 120S4M	120/S4B, 150			MERV 8	MERV 13
1750	0.02	0.03	0.04	0.03	0.03	0.01	0.03
2000	0.02	0.04	0.05	0.03	0.05	0.01	0.03
2250	0.03	0.05	0.06	0.04	0.06	0.01	0.04
2500	0.03	0.05	0.07	0.04	0.08	0.01	0.05
2750	0.04	0.06	0.08	0.05	0.09	0.02	0.05
3000	0.05	0.07	0.09	0.06	0.11	0.02	0.06
3250	0.05	0.08	0.10	0.06	0.13	0.02	0.06
3500	0.06	0.09	0.11	0.09	0.15	0.03	0.07
3750	0.07	0.10	0.13	0.09	0.17	0.03	0.08
4000	0.07	0.11	0.14	0.09	0.19	0.04	0.08
4250	0.08	0.13	0.15	0.13	0.21	0.04	0.09
4500	0.09	0.14	0.17	0.14	0.24	0.04	0.09
4750	0.10	0.15	0.18	0.17	0.26	0.05	0.10
5000	0.10	0.16	0.20	0.20	0.29	0.06	0.10
5250	0.11	0.17	0.22	0.22	0.32	0.06	0.11
5500	0.12	0.19	0.23	0.25	0.34	0.07	0.12
5750	0.13	0.20	0.25	0.31	0.37	0.07	0.12
6000	0.14	0.22	0.27	0.33	0.40	0.08	0.13



## BLOWER DATA

### CEILING DIFFUSERS AIR RESISTANCE - in. w.g.

Unit Size	RTD11 Step-Down Diffuser			FD11 Flush Diffuser	
	Air Volume cfm	2 Ends Open	1 Side, 2 Ends Open		All Ends & Sides Open
092 Models	2400	0.21	0.18	0.15	0.14
	2600	0.24	0.21	0.18	0.17
	2800	0.27	0.24	0.21	0.20
	3000	0.32	0.29	0.25	0.25
	3200	0.41	0.37	0.32	0.31
	3400	0.50	0.45	0.39	0.37
	3600	0.61	0.54	0.48	0.44
102 & 120S4M Models	3800	0.73	0.63	0.57	0.51
	3600	0.36	0.28	0.23	0.15
	3800	0.40	0.32	0.26	0.18
	4000	0.44	0.36	0.29	0.21
	4200	0.49	0.40	0.33	0.24
	4400	0.54	0.44	0.37	0.27
	4600	0.60	0.49	0.42	0.31
	4800	0.65	0.53	0.46	0.35
120S4B & 150 Models	5000	0.69	0.58	0.50	0.39
	5200	0.75	0.62	0.54	0.43
	4200	0.22	0.19	0.16	0.10
	4400	0.28	0.24	0.20	0.12
	4600	0.34	0.29	0.24	0.15
	4800	0.40	0.34	0.29	0.19
	5000	0.46	0.39	0.34	0.23
	5200	0.52	0.44	0.39	0.27
	5400	0.58	0.49	0.43	0.31
5600	0.64	0.54	0.47	0.35	
5800	0.70	0.59	0.51	0.39	

### CEILING DIFFUSER AIR THROW DATA

Model No.	Air Volume cfm	<sup>1</sup> Effective Throw Range	
		RTD11 Step-Down ft.	FD11 Flush ft.
092 Models	2600	24 - 29	19 - 24
	2800	25 - 30	20 - 28
	3000	27 - 33	21 - 29
	3200	28 - 35	22 - 29
	3400	30 - 37	22 - 30
102, 120 Models	3600	25 - 33	22 - 29
	3800	27 - 35	22 - 30
	4000	29 - 37	24 - 33
	4200	32 - 40	26 - 35
	4400	34 - 42	28 - 37
150 Models	5600	39 - 49	28 - 37
	5800	42 - 51	29 - 38
	6000	44 - 54	40 - 50
	6200	45 - 55	42 - 51
	6400	46 - 55	43 - 52
6600	47 - 56	45 - 56	

<sup>1</sup> Throw is the horizontal or vertical distance an air stream travels on leaving the outlet or diffuser before the maximum velocity is reduced to 50 ft. per minute. Four sides open.

**ELECTRICAL/ELECTRIC HEAT DATA**

**7.5 TON**

**7.5 TON STANDARD EFFICIENCY - CONSTANT AIR VOLUME**

**ZCB092S4B**

<sup>1</sup> Voltage - 60hz		208/230V - 3 Ph			460V - 3 Ph			575V - 3 Ph		
Compressor 1	Rated Load Amps	13.5			8			5		
	Locked Rotor Amps	109			59			40		
Compressor 2	Rated Load Amps	8.7			4			3.6		
	Locked Rotor Amps	70			31			27		
Outdoor Fan Motors (2)	Full Load Amps	2.4			1.3			1.0		
	(total)	(4.8)			(2.6)			(2.0)		
Power Exhaust (2) 0.5 HP	Full Load Amps	1.5			0.6			0.6		
	(total)	(3.0)			(1.2)			(1.2)		
Indoor Blower Motor	Horsepower	2	3	5	2	3	5	2	3	5
	Full Load Amps	7.5	10.6	16.7	3.4	4.8	7.6	2.7	3.9	6.1
<sup>2</sup> Maximum Overcurrent Protection	Unit Only	50	50	60	25	25	30	15	20	20
	With (2) 0.5 HP Power Exhaust	50	50	60	25	30	30	20	20	25
<sup>3</sup> Minimum Circuit Ampacity	Unit Only	38	41	48	20	22	25	15	16	19
	With (2) 0.5 HP Power Exhaust	41	44	51	22	23	26	16	17	20

**ELECTRIC HEAT DATA**

Electric Heat Voltage			208V	240V	208V	240V	208V	240V	480V	480V	480V	600V	600V	600V
<sup>2</sup> Maximum Overcurrent Protection	Unit+ Electric Heat	7.5 kW	50	50	50	50	60	60	25	25	30	15	20	20
		15 kW	<sup>4</sup> 50	60	60	60	<sup>4</sup> 60	70	30	30	35	25	25	30
		22.5 kW	<sup>4</sup> 70	80	<sup>4</sup> 80	90	<sup>4</sup> 80	90	40	40	45	35	35	35
		30 kW	<sup>4</sup> 90	100	<sup>4</sup> 100	110	<sup>4</sup> 100	125	50	60	60	40	45	45
		45 kW	150	150	150	150	<sup>4</sup> 150	175	80	80	80	60	60	70
<sup>3</sup> Minimum Circuit Ampacity	Unit+ Electric Heat	7.5 kW	38	38	41	41	48	48	20	22	25	15	16	19
		15 kW	49	55	53	59	60	66	27	29	33	22	23	26
		22.5 kW	69	78	72	81	80	89	39	40	44	31	32	35
		30 kW	88	100	92	104	100	112	50	52	55	40	41	44
		45 kW	127	145	131	149	139	157	72	74	78	58	60	62
<sup>2</sup> Maximum Overcurrent Protection	Unit+ Electric Heat and (2) 0.5 HP Power Exhaust	7.5 kW	50	50	50	50	60	60	25	30	30	20	20	25
		15 kW	60	60	<sup>4</sup> 60	70	70	70	30	35	35	25	25	30
		22.5 kW	<sup>4</sup> 80	90	<sup>4</sup> 80	90	<sup>4</sup> 90	100	40	45	45	35	35	40
		30 kW	<sup>4</sup> 100	110	<sup>4</sup> 100	110	<sup>4</sup> 110	125	60	60	60	45	45	50
		45 kW	150	150	<sup>4</sup> 150	175	<sup>4</sup> 150	175	80	80	80	60	70	70
<sup>3</sup> Minimum Circuit Ampacity	Unit+ Electric Heat and (2) 0.5 HP Power Exhaust	7.5 kW	41	41	44	44	51	51	22	23	26	16	17	20
		15 kW	53	59	57	63	64	70	29	31	34	23	25	28
		22.5 kW	72	81	76	85	84	93	40	42	45	32	34	37
		30 kW	92	104	96	108	103	115	51	53	57	41	43	46
		45 kW	131	149	135	153	142	160	74	76	79	60	61	64

**ELECTRIC HEAT ACCESSORIES**

Unit Fuse Block	Unit Only	10Z41	10Z41	10Z41	10Z41	10Z41	10Z41	10Z39	10Z39	10Z39	10Z38	10Z38	10Z38
	Unit + Power Exhaust	10Z41	10Z41	10Z41	10Z41	10Z42	10Z42	10Z39	10Z39	10Z40	10Z38	10Z38	10Z39

NOTE - All units have a minimum Short Circuit Current Rating (SCCR) of 5000 amps.

<sup>1</sup> Extremes of operating range are plus and minus 10% of line voltage.

<sup>2</sup> HACR type breaker or fuse.

<sup>3</sup> Refer to National or Canadian Electrical Code manual to determine wire, fuse and disconnect size requirements.

<sup>4</sup> Factory installed circuit breaker not available.

**ELECTRICAL/ELECTRIC HEAT DATA**

**7.5 TON**

**7.5 TON STANDARD EFFICIENCY - MSAV® (MULTI-STAGE AIR VOLUME) SUPPLY AIR**

**ZCA092S4M**

<sup>1</sup> Voltage - 60hz		208/230V - 3 Ph			460V - 3 Ph			575V - 3 Ph		
Compressor 1	Rated Load Amps	13.5			8			5		
	Locked Rotor Amps	109			59			40		
Compressor 2	Rated Load Amps	8.7			4			3.6		
	Locked Rotor Amps	70			31			27		
Outdoor Fan Motors (2)	Full Load Amps	2.4			1.3			1.0		
	(total)	(4.8)			(2.6)			(2.0)		
Power Exhaust (2) 0.5 HP	Full Load Amps	1.5			0.6			0.6		
	(total)	(3.0)			(1.2)			(1.2)		
Indoor Blower Motor	Horsepower	2	3	5	2	3	5	2	3	5
	Full Load Amps	7.5	10.6	16.7	3.4	4.8	7.6	2.7	3.9	6.1
<sup>2</sup> Maximum Overcurrent Protection	Unit Only	50	50	60	25	25	30	15	20	20
	With (2) 0.5 HP Power Exhaust	50	50	60	25	30	30	20	20	25
<sup>3</sup> Minimum Circuit Ampacity	Unit Only	38	41	48	20	22	25	15	16	19
	With (2) 0.5 HP Power Exhaust	41	44	51	22	23	26	16	17	20

**ELECTRIC HEAT DATA**

Electric Heat Voltage			208V	240V	208V	240V	208V	240V	480V	480V	480V	600V	600V	600V
<sup>2</sup> Maximum Overcurrent Protection	Unit+ Electric Heat	7.5 kW	50	50	50	50	60	60	25	25	30	15	20	20
		15 kW	<sup>4</sup> 50	60	60	60	<sup>4</sup> 60	70	30	30	35	25	25	30
		22.5 kW	<sup>4</sup> 70	80	<sup>4</sup> 80	90	<sup>4</sup> 80	90	40	40	45	35	35	35
		30 kW	<sup>4</sup> 90	100	<sup>4</sup> 100	110	<sup>4</sup> 100	125	50	60	60	40	45	45
		45 kW	150	150	150	150	<sup>4</sup> 150	175	80	80	80	60	60	70
<sup>3</sup> Minimum Circuit Ampacity	Unit+ Electric Heat	7.5 kW	38	38	41	41	48	48	20	22	25	15	16	19
		15 kW	49	55	53	59	60	66	27	29	33	22	23	26
		22.5 kW	69	78	72	81	80	89	39	40	44	31	32	35
		30 kW	88	100	92	104	100	112	50	52	55	40	41	44
		45 kW	127	145	131	149	139	157	72	74	78	58	60	62
<sup>2</sup> Maximum Overcurrent Protection	Unit+ Electric Heat and (2) 0.5 HP Power Exhaust	7.5 kW	50	50	50	50	60	60	25	30	30	20	20	25
		15 kW	60	60	<sup>4</sup> 60	70	70	70	30	35	35	25	25	30
		22.5 kW	<sup>4</sup> 80	90	<sup>4</sup> 80	90	<sup>4</sup> 90	100	40	45	45	35	35	40
		30 kW	<sup>4</sup> 100	110	<sup>4</sup> 100	110	<sup>4</sup> 110	125	60	60	60	45	45	50
		45 kW	150	150	<sup>4</sup> 150	175	<sup>4</sup> 150	175	80	80	80	60	70	70
<sup>3</sup> Minimum Circuit Ampacity	Unit+ Electric Heat and (2) 0.5 HP Power Exhaust	7.5 kW	41	41	44	44	51	51	22	23	26	16	17	20
		15 kW	53	59	57	63	64	70	29	31	34	23	25	28
		22.5 kW	72	81	76	85	84	93	40	42	45	32	34	37
		30 kW	92	104	96	108	103	115	51	53	57	41	43	46
		45 kW	131	149	135	153	142	160	74	76	79	60	61	64

**ELECTRIC HEAT ACCESSORIES**

Unit Fuse Block	Unit Only	10Z41	10Z41	10Z41	10Z41	10Z41	10Z41	10Z39	10Z39	10Z39	10Z38	10Z38	10Z38
	Unit + Power Exhaust	10Z41	10Z41	10Z41	10Z41	10Z42	10Z42	10Z39	10Z39	10Z40	10Z38	10Z38	10Z39

NOTE - All units have a minimum Short Circuit Current Rating (SCCR) of 5000 amps.

<sup>1</sup> Extremes of operating range are plus and minus 10% of line voltage.

<sup>2</sup> HACR type breaker or fuse.

<sup>3</sup> Refer to National or Canadian Electrical Code manual to determine wire, fuse and disconnect size requirements.

<sup>4</sup> Factory installed circuit breaker not available.

**ELECTRICAL/ELECTRIC HEAT DATA**

**8.5 TON**

**8.5 TON STANDARD EFFICIENCY - CONSTANT AIR VOLUME**

**ZCB102S4B**

<sup>1</sup> Voltage - 60hz		208/230V - 3 Ph			460V - 3 Ph			575V - 3 Ph		
Compressor 1	Rated Load Amps	13.5			8			5		
	Locked Rotor Amps	109			59			40		
Compressor 2	Rated Load Amps	11			5.5			4.7		
	Locked Rotor Amps	86			37			34		
Outdoor Fan Motors (2)	Full Load Amps	2.4			1.3			1.0		
	(total)	(4.8)			(2.6)			(2.0)		
Power Exhaust (2) 0.5 HP	Full Load Amps	1.5			0.6			0.6		
	(total)	(3.0)			(1.2)			(1.2)		
Indoor Blower Motor	Horsepower	2	3	5	2	3	5	2	3	5
	Full Load Amps	7.5	10.6	16.7	3.4	4.8	7.6	2.7	3.9	6.1
<sup>2</sup> Maximum Overcurrent Protection	Unit Only	50	50	60	25	30	30	20	20	25
	With (2) 0.5 HP Power Exhaust	50	50	60	30	30	30	20	20	25
<sup>3</sup> Minimum Circuit Ampacity	Unit Only	41	44	51	22	23	26	16	17	20
	With (2) 0.5 HP Power Exhaust	44	47	54	23	25	27	17	19	21

**ELECTRIC HEAT DATA**

Electric Heat Voltage			208V	240V	208V	240V	208V	240V	480V	480V	480V	600V	600V	600V
<sup>2</sup> Maximum Overcurrent Protection	Unit+ Electric Heat	7.5 kW	50	50	50	50	60	60	25	30	30	20	20	25
		15 kW	<sup>4</sup> 50	60	60	60	<sup>4</sup> 60	70	30	30	35	25	25	30
		22.5 kW	<sup>4</sup> 70	80	<sup>4</sup> 80	90	<sup>4</sup> 80	90	40	40	45	35	35	35
		30 kW	<sup>4</sup> 90	100	<sup>4</sup> 100	110	<sup>4</sup> 100	125	50	60	60	40	45	45
		45 kW	150	150	150	150	<sup>4</sup> 150	175	80	80	80	60	60	70
<sup>3</sup> Minimum Circuit Ampacity	Unit+ Electric Heat	7.5 kW	41	41	44	44	51	51	22	23	26	16	17	20
		15 kW	49	55	53	59	60	66	27	29	33	22	23	26
		22.5 kW	69	78	72	81	80	89	39	40	44	31	32	35
		30 kW	88	100	92	104	100	112	50	52	55	40	41	44
		45 kW	127	145	131	149	139	157	72	74	78	58	60	62
<sup>2</sup> Maximum Overcurrent Protection	Unit+ Electric Heat and (2) 0.5 HP Power Exhaust	7.5 kW	50	50	50	50	60	60	30	30	30	20	20	25
		15 kW	60	60	<sup>4</sup> 60	70	70	70	30	35	35	25	25	30
		22.5 kW	<sup>4</sup> 80	90	<sup>4</sup> 80	90	<sup>4</sup> 90	100	40	45	45	35	35	40
		30 kW	<sup>4</sup> 100	110	<sup>4</sup> 100	110	<sup>4</sup> 110	125	60	60	60	45	45	50
		45 kW	150	150	<sup>4</sup> 150	175	<sup>4</sup> 150	175	80	80	80	60	70	70
<sup>3</sup> Minimum Circuit Ampacity	Unit+ Electric Heat and (2) 0.5 HP Power Exhaust	7.5 kW	44	44	47	47	54	54	23	25	27	17	19	21
		15 kW	53	59	57	63	64	70	29	31	34	23	25	28
		22.5 kW	72	81	76	85	84	93	40	42	45	32	34	37
		30 kW	92	104	96	108	103	115	51	53	57	41	43	46
		45 kW	131	149	135	153	142	160	74	76	79	60	61	64

**ELECTRIC HEAT ACCESSORIES**

Unit Fuse Block	Unit Only	10Z41	10Z41	10Z41	10Z41	10Z41	10Z41	10Z39	10Z39	10Z39	10Z38	10Z38	10Z39
	Unit + Power Exhaust	10Z41	10Z41	10Z41	10Z41	10Z42	10Z42	10Z39	10Z39	10Z40	10Z38	10Z39	10Z39

NOTE - All units have a minimum Short Circuit Current Rating (SCCR) of 5000 amps.

<sup>1</sup> Extremes of operating range are plus and minus 10% of line voltage.

<sup>2</sup> HACR type breaker or fuse.

<sup>3</sup> Refer to National or Canadian Electrical Code manual to determine wire, fuse and disconnect size requirements.

<sup>4</sup> Factory installed circuit breaker not available.

**ELECTRICAL/ELECTRIC HEAT DATA**

**8.5 TON**

**8.5 TON STANDARD EFFICIENCY - MSAV® (MULTI-STAGE AIR VOLUME) SUPPLY AIR**

**ZCA102S4M**

<sup>1</sup> Voltage - 60hz		208/230V - 3 Ph			460V - 3 Ph			575V - 3 Ph		
Compressor 1	Rated Load Amps	13.5			8			5		
	Locked Rotor Amps	109			59			40		
Compressor 2	Rated Load Amps	11			5.5			4.7		
	Locked Rotor Amps	86			37			34		
Outdoor Fan Motors (2)	Full Load Amps	2.4			1.3			1.0		
	(total)	(4.8)			(2.6)			(2.0)		
Power Exhaust (2) 0.5 HP	Full Load Amps	1.5			0.6			0.6		
	(total)	(3.0)			(1.2)			(1.2)		
Indoor Blower Motor	Horsepower	2	3	5	2	3	5	2	3	5
	Full Load Amps	7.5	10.6	16.7	3.4	4.8	7.6	2.7	3.9	6.1
<sup>2</sup> Maximum Overcurrent Protection	Unit Only	50	50	60	25	30	30	20	20	25
	With (2) 0.5 HP Power Exhaust	50	50	60	30	30	30	20	20	25
<sup>3</sup> Minimum Circuit Ampacity	Unit Only	41	44	51	22	23	26	16	17	20
	With (2) 0.5 HP Power Exhaust	44	47	54	23	25	27	17	19	21

**ELECTRIC HEAT DATA**

Electric Heat Voltage			208V	240V	208V	240V	208V	240V	480V	480V	480V	600V	600V	600V
<sup>2</sup> Maximum Overcurrent Protection	Unit+ Electric Heat	7.5 kW	50	50	50	50	60	60	25	30	30	20	20	25
		15 kW	<sup>4</sup> 50	60	60	60	<sup>4</sup> 60	70	30	30	35	25	25	30
		22.5 kW	<sup>4</sup> 70	80	<sup>4</sup> 80	90	<sup>4</sup> 80	90	40	40	45	35	35	35
		30 kW	<sup>4</sup> 90	100	<sup>4</sup> 100	110	<sup>4</sup> 100	125	50	60	60	40	45	45
		45 kW	150	150	150	150	<sup>4</sup> 150	175	80	80	80	60	60	70
<sup>3</sup> Minimum Circuit Ampacity	Unit+ Electric Heat	7.5 kW	41	41	44	44	51	51	22	23	26	16	17	20
		15 kW	49	55	53	59	60	66	27	29	33	22	23	26
		22.5 kW	69	78	72	81	80	89	39	40	44	31	32	35
		30 kW	88	100	92	104	100	112	50	52	55	40	41	44
		45 kW	127	145	131	149	139	157	72	74	78	58	60	62
<sup>2</sup> Maximum Overcurrent Protection	Unit+ Electric Heat and (2) 0.5 HP Power Exhaust	7.5 kW	50	50	50	50	60	60	30	30	30	20	20	25
		15 kW	60	60	<sup>4</sup> 60	70	70	70	30	35	35	25	25	30
		22.5 kW	<sup>4</sup> 80	90	<sup>4</sup> 80	90	<sup>4</sup> 90	100	40	45	45	35	35	40
		30 kW	<sup>4</sup> 100	110	<sup>4</sup> 100	110	<sup>4</sup> 110	125	60	60	60	45	45	50
		45 kW	150	150	<sup>4</sup> 150	175	<sup>4</sup> 150	175	80	80	80	60	70	70
<sup>3</sup> Minimum Circuit Ampacity	Unit+ Electric Heat and (2) 0.5 HP Power Exhaust	7.5 kW	44	44	47	47	54	54	23	25	27	17	19	21
		15 kW	53	59	57	63	64	70	29	31	34	23	25	28
		22.5 kW	72	81	76	85	84	93	40	42	45	32	34	37
		30 kW	92	104	96	108	103	115	51	53	57	41	43	46
		45 kW	131	149	135	153	142	160	74	76	79	60	61	64

**ELECTRIC HEAT ACCESSORIES**

Unit Fuse Block	Unit Only	10Z41	10Z41	10Z41	10Z41	10Z41	10Z41	10Z39	10Z39	10Z39	10Z38	10Z38	10Z39
	Unit + Power Exhaust	10Z41	10Z41	10Z41	10Z41	10Z42	10Z42	10Z39	10Z39	10Z40	10Z38	10Z39	10Z39

NOTE - All units have a minimum Short Circuit Current Rating (SCCR) of 5000 amps.

<sup>1</sup> Extremes of operating range are plus and minus 10% of line voltage.

<sup>2</sup> HACR type breaker or fuse.

<sup>3</sup> Refer to National or Canadian Electrical Code manual to determine wire, fuse and disconnect size requirements.

<sup>4</sup> Factory installed circuit breaker not available.

**ELECTRICAL/ELECTRIC HEAT DATA**

**10 TON**

**10 TON STANDARD EFFICIENCY - CONSTANT AIR VOLUME**

**ZCB120S4B**

<sup>1</sup> Voltage - 60hz		208/230V - 3 Ph			460V - 3 Ph			575V - 3 Ph		
Compressor 1	Rated Load Amps	13.5			8			5		
	Locked Rotor Amps	109			59			40		
Compressor 2	Rated Load Amps	13.5			8			5		
	Locked Rotor Amps	109			59			40		
Outdoor Fan Motors (2)	Full Load Amps	2.4			1.3			1.0		
	(total)	(4.8)			(2.6)			(2.0)		
Power Exhaust (2) 0.5 HP	Full Load Amps	1.5			0.6			0.6		
	(total)	(3.0)			(1.2)			(1.2)		
Indoor Blower Motor	Horsepower	2	3	5	2	3	5	2	3	5
	Full Load Amps	7.5	10.6	16.7	3.4	4.8	7.6	2.7	3.9	6.1
<sup>2</sup> Maximum Overcurrent Protection	Unit Only	50	50	60	30	30	35	20	20	25
	With (2) 0.5 HP Power Exhaust	50	60	70	30	30	35	20	20	25
<sup>3</sup> Minimum Circuit Ampacity	Unit Only	43	46	53	24	26	29	16	18	20
	With (2) 0.5 HP Power Exhaust	46	49	56	26	27	30	18	19	21

**ELECTRIC HEAT DATA**

Electric Heat Voltage			208V	240V	208V	240V	208V	240V	480V	480V	480V	600V	600V	600V
<sup>2</sup> Maximum Overcurrent Protection	Unit+ 15 kW	Electric Heat	<sup>4</sup> 50	60	60	60	<sup>4</sup> 60	70	30	30	35	25	25	30
	22.5 kW		<sup>4</sup> 70	80	<sup>4</sup> 80	90	<sup>4</sup> 80	90	40	40	45	35	35	35
	30 kW		<sup>4</sup> 90	100	<sup>4</sup> 100	110	<sup>4</sup> 100	125	50	60	60	40	45	45
	45 kW		150	150	150	150	<sup>4</sup> 150	175	80	80	80	60	60	70
	60 kW		<sup>4</sup> 150	175	<sup>4</sup> 150	175	<sup>4</sup> 150	175	80	80	90	70	70	70
<sup>3</sup> Minimum Circuit Ampacity	Unit+ 15 kW	Electric Heat	49	55	53	59	60	66	27	29	33	22	23	26
	22.5 kW		69	78	72	81	80	89	39	40	44	31	32	35
	30 kW		88	100	92	104	100	112	50	52	55	40	41	44
	45 kW		127	145	131	149	139	157	72	74	78	58	60	62
	60 kW		135	154	139	158	146	166	77	79	82	62	63	66
<sup>2</sup> Maximum Overcurrent Protection	Unit+ 15 kW	Electric Heat and (2) 0.5 HP Power Exhaust	60	60	<sup>4</sup> 60	70	70	70	30	35	35	25	25	30
	22.5 kW		<sup>4</sup> 80	90	<sup>4</sup> 80	90	<sup>4</sup> 90	100	40	45	45	35	35	40
	30 kW		<sup>4</sup> 100	110	<sup>4</sup> 100	110	<sup>4</sup> 110	125	60	60	60	45	45	50
	45 kW		150	150	<sup>4</sup> 150	175	<sup>4</sup> 150	175	80	80	80	60	70	70
	60 kW		<sup>4</sup> 150	175	<sup>4</sup> 150	175	<sup>4</sup> 150	175	80	80	90	70	70	70
<sup>3</sup> Minimum Circuit Ampacity	Unit+ 15 kW	Electric Heat and (2) 0.5 HP Power Exhaust	53	59	57	63	64	70	29	31	34	23	25	28
	22.5 kW		72	81	76	85	84	93	40	42	45	32	34	37
	30 kW		92	104	96	108	103	115	51	53	57	41	43	46
	45 kW		131	149	135	153	142	160	74	76	79	60	61	64
	60 kW		139	158	143	162	150	169	78	80	84	63	65	67

**ELECTRIC HEAT ACCESSORIES**

Unit Fuse Block	Unit Only	<b>10Z41</b>	<b>10Z41</b>	<b>10Z41</b>	<b>10Z41</b>	<b>10Z41</b>	<b>10Z41</b>	<b>10Z39</b>	<b>10Z39</b>	<b>10Z40</b>	<b>10Z38</b>	<b>10Z38</b>	<b>10Z39</b>
	Unit + Power Exhaust	<b>10Z41</b>	<b>10Z41</b>	<b>10Z41</b>	<b>10Z41</b>	<b>10Z42</b>	<b>10Z42</b>	<b>10Z40</b>	<b>10Z40</b>	<b>10Z40</b>	<b>10Z38</b>	<b>10Z39</b>	<b>10Z39</b>

NOTE - All units have a minimum Short Circuit Current Rating (SCCR) of 5000 amps.

<sup>1</sup> Extremes of operating range are plus and minus 10% of line voltage.

<sup>2</sup> HACR type breaker or fuse.

<sup>3</sup> Refer to National or Canadian Electrical Code manual to determine wire, fuse and disconnect size requirements.

<sup>4</sup> Factory installed circuit breaker not available.

**ELECTRICAL/ELECTRIC HEAT DATA**

**10 TON**

**10 TON STANDARD EFFICIENCY - MSAV® (MULTI-STAGE AIR VOLUME) SUPPLY AIR**

**ZCA120S4M**

<sup>1</sup> Voltage - 60hz		208/230V - 3 Ph			460V - 3 Ph			575V - 3 Ph		
Compressor 1	Rated Load Amps	13.5			8			5		
	Locked Rotor Amps	109			59			40		
Compressor 2	Rated Load Amps	13.5			8			5		
	Locked Rotor Amps	109			59			40		
Outdoor Fan Motors (2)	Full Load Amps	2.4			1.3			1.0		
	(total)	(4.8)			(2.6)			(2.0)		
Power Exhaust (2) 0.5 HP	Full Load Amps	1.5			0.6			0.6		
	(total)	(3.0)			(1.2)			(1.2)		
Indoor Blower Motor	Horsepower	2	3	5	2	3	5	2	3	5
	Full Load Amps	7.5	10.6	16.7	3.4	4.8	7.6	2.7	3.9	6.1
<sup>2</sup> Maximum Overcurrent Protection	Unit Only	50	50	60	30	30	35	20	20	25
	With (2) 0.5 HP Power Exhaust	50	60	70	30	30	35	20	20	25
<sup>3</sup> Minimum Circuit Ampacity	Unit Only	43	46	53	24	26	29	16	18	20
	With (2) 0.5 HP Power Exhaust	46	49	56	26	27	30	18	19	21

**ELECTRIC HEAT DATA**

Electric Heat Voltage			208V	240V	208V	240V	208V	240V	480V	480V	480V	600V	600V	600V
<sup>2</sup> Maximum Overcurrent Protection	Unit+ Electric Heat	15 kW	<sup>4</sup> 50	60	60	60	<sup>4</sup> 60	70	30	30	35	25	25	30
		22.5 kW	<sup>4</sup> 70	80	<sup>4</sup> 80	90	<sup>4</sup> 80	90	40	40	45	35	35	35
		30 kW	<sup>4</sup> 90	100	<sup>4</sup> 100	110	<sup>4</sup> 100	125	50	60	60	40	45	45
		45 kW	150	150	150	150	<sup>4</sup> 150	175	80	80	80	60	60	70
		60 kW	<sup>4</sup> 150	175	<sup>4</sup> 150	175	<sup>4</sup> 150	175	80	80	90	70	70	70
<sup>3</sup> Minimum Circuit Ampacity	Unit+ Electric Heat	15 kW	49	55	53	59	60	66	27	29	33	22	23	26
		22.5 kW	69	78	72	81	80	89	39	40	44	31	32	35
		30 kW	88	100	92	104	100	112	50	52	55	40	41	44
		45 kW	127	145	131	149	139	157	72	74	78	58	60	62
		60 kW	135	154	139	158	146	166	77	79	82	62	63	66
<sup>2</sup> Maximum Overcurrent Protection	Unit+ Electric Heat and (2) 0.5 HP Power Exhaust	15 kW	60	60	<sup>4</sup> 60	70	70	70	30	35	35	25	25	30
		22.5 kW	<sup>4</sup> 80	90	<sup>4</sup> 80	90	<sup>4</sup> 90	100	40	45	45	35	35	40
		30 kW	<sup>4</sup> 100	110	<sup>4</sup> 100	110	<sup>4</sup> 110	125	60	60	60	45	45	50
		45 kW	150	150	<sup>4</sup> 150	175	<sup>4</sup> 150	175	80	80	80	60	70	70
		60 kW	<sup>4</sup> 150	175	<sup>4</sup> 150	175	<sup>4</sup> 150	175	80	80	90	70	70	70
<sup>3</sup> Minimum Circuit Ampacity	Unit+ Electric Heat and (2) 0.5 HP Power Exhaust	15 kW	53	59	57	63	64	70	29	31	34	23	25	28
		22.5 kW	72	81	76	85	84	93	40	42	45	32	34	37
		30 kW	92	104	96	108	103	115	51	53	57	41	43	46
		45 kW	131	149	135	153	142	160	74	76	79	60	61	64
		60 kW	139	158	143	162	150	169	78	80	84	63	65	67

**ELECTRIC HEAT ACCESSORIES**

Unit Fuse Block	Unit Only	10Z41	10Z41	10Z41	10Z41	10Z41	10Z41	10Z39	10Z39	10Z40	10Z38	10Z38	10Z39
	Unit + Power Exhaust	10Z41	10Z41	10Z41	10Z41	10Z42	10Z42	10Z40	10Z40	10Z40	10Z38	10Z39	10Z39

NOTE - All units have a minimum Short Circuit Current Rating (SCCR) of 5000 amps.

<sup>1</sup> Extremes of operating range are plus and minus 10% of line voltage.

<sup>2</sup> HACR type breaker or fuse.

<sup>3</sup> Refer to National or Canadian Electrical Code manual to determine wire, fuse and disconnect size requirements.

<sup>4</sup> Factory installed circuit breaker not available.

**ELECTRICAL/ELECTRIC HEAT DATA**

**12.5 TON**

**12.5 TON STANDARD EFFICIENCY - CONSTANT AIR VOLUME**

**ZCB150S4B**

<sup>1</sup> Voltage - 60hz		208/230V - 3 Ph			460V - 3 Ph			575V - 3 Ph		
Compressor 1	Rated Load Amps	19.6			8.2			6.6		
	Locked Rotor Amps	136			66.1			55.3		
Compressor 2	Rated Load Amps	22.4			10.6			7.7		
	Locked Rotor Amps	149			75			54		
Outdoor Fan Motors (2)	Full Load Amps	3.0			1.5			1.2		
	(total)	(6.0)			(3.0)			(2.4)		
Power Exhaust (2) 0.5 HP	Full Load Amps	1.5			0.6			0.6		
	(total)	(3)			(1.2)			(1.2)		
Indoor Blower Motor	Horsepower	2	3	5	2	3	5	2	3	5
	Full Load Amps	7.5	10.6	16.7	3.4	4.8	7.6	2.7	3.9	6.1
<sup>2</sup> Maximum Overcurrent Protection	Unit Only	80	80	90	35	35	40	25	30	30
	With (2) 0.5 HP Power Exhaust	80	80	90	35	40	40	30	30	30
<sup>3</sup> Minimum Circuit Ampacity	Unit Only	62	65	71	28	30	33	22	23	25
	With (2) 0.5 HP Power Exhaust	65	68	74	30	31	34	23	24	26

**ELECTRIC HEAT DATA**

Electric Heat Voltage			208V	240V	208V	240V	208V	240V	480V	480V	480V	600V	600V	600V
<sup>2</sup> Maximum Overcurrent Protection	Unit+ 15 kW	80	80	80	80	90	90	35	35	40	25	30	30	
	Electric Heat 22.5 kW	80	80	4 80	90	90	90	40	40	45	35	35	35	
	30 kW	4 90	100	4 100	110	4 100	125	50	60	60	40	45	45	
	45 kW	150	150	150	150	4 150	175	80	80	80	60	60	70	
	60 kW	4 150	175	4 150	175	4 150	175	80	80	90	70	70	70	
<sup>3</sup> Minimum Circuit Ampacity	Unit+ 15 kW	62	62	65	65	71	71	28	30	33	22	23	26	
	Electric Heat 22.5 kW	69	78	72	81	80	89	39	40	44	31	32	35	
	30 kW	88	100	92	104	100	112	50	52	55	40	41	44	
	45 kW	127	145	131	149	139	157	72	74	78	58	60	62	
	60 kW	135	154	139	158	146	166	77	79	82	62	63	66	
<sup>2</sup> Maximum Overcurrent Protection	Unit+ 15 kW	80	80	80	80	90	90	35	40	40	30	30	30	
	Electric Heat and (2) 0.5 HP Power Exhaust 22.5 kW	4 80	90	4 80	90	4 90	100	40	45	45	35	35	40	
	30 kW	4 100	110	4 100	110	4 110	125	60	60	60	45	45	50	
	45 kW	150	150	4 150	175	4 150	175	80	80	80	60	70	70	
	60 kW	4 150	175	4 150	175	4 150	175	80	80	90	70	70	70	
<sup>3</sup> Minimum Circuit Ampacity	Unit+ 15 kW	65	65	68	68	74	74	30	31	34	23	25	28	
	Electric Heat and (2) 0.5 HP Power Exhaust 22.5 kW	72	81	76	85	84	93	40	42	45	32	34	37	
	30 kW	92	104	96	108	103	115	51	53	57	41	43	46	
	45 kW	131	149	135	153	142	160	74	76	79	60	61	64	
	60 kW	139	158	143	162	150	169	78	80	84	63	65	67	

**ELECTRIC HEAT ACCESSORIES**

Unit Fuse Block	Unit Only	10Z42	10Z42	10Z42	10Z42	10Z42	10Z42	10Z39	10Z39	10Z40	10Z39	10Z39	10Z39
	Unit + Power Exhaust	10Z42	10Z42	10Z42	10Z42	10Z42	10Z42	10Z40	10Z40	10Z40	10Z39	10Z39	10Z39

NOTE - All units have a minimum Short Circuit Current Rating (SCCR) of 5000 amps.

<sup>1</sup> Extremes of operating range are plus and minus 10% of line voltage.

<sup>2</sup> HACR type breaker or fuse.

<sup>3</sup> Refer to National or Canadian Electrical Code manual to determine wire, fuse and disconnect size requirements.

<sup>4</sup> Factory installed circuit breaker not available.



**ELECTRICAL/ELECTRIC HEAT DATA**

**12.5 TON**

**12.5 TON STANDARD EFFICIENCY - MSAV® (MULTI-STAGE AIR VOLUME) SUPPLY AIR**

**ZCA150S4M**

<sup>1</sup> Voltage - 60hz		208/230V - 3 Ph			460V - 3 Ph			575V - 3 Ph		
Compressor 1	Rated Load Amps	19.6			8.2			6.6		
	Locked Rotor Amps	136			66.1			55.3		
Compressor 2	Rated Load Amps	19.6			8.2			6.6		
	Locked Rotor Amps	136			66.1			55.3		
Outdoor Fan Motors (2)	Full Load Amps	3.0			1.5			1.2		
	(total)	(6.0)			(3.0)			(2.4)		
Power Exhaust (2) 0.5 HP	Full Load Amps	1.5			0.6			0.6		
	(total)	(3.0)			(1.2)			(1.2)		
Indoor Blower Motor	Horsepower	2	3	5	2	3	5	2	3	5
	Full Load Amps	7.5	10.6	16.7	3.4	4.8	7.6	2.7	3.9	6.1
<sup>2</sup> Maximum Overcurrent Protection	Unit Only	70	80	80	30	30	35	25	25	25
	With (2) 0.5 HP Power Exhaust	80	80	80	30	35	35	25	25	30
<sup>3</sup> Minimum Circuit Ampacity	Unit Only	58	61	67	25	27	30	20	22	24
	With (2) 0.5 HP Power Exhaust	61	64	70	27	28	31	22	23	25

**ELECTRIC HEAT DATA**

Electric Heat Voltage			208V	240V	208V	240V	208V	240V	480V	480V	480V	600V	600V	600V
<sup>2</sup> Maximum Overcurrent Protection	Unit+ 15 kW	Electric Heat	70	70	80	80	80	80	30	30	35	25	25	30
	22.5 kW	Electric Heat	<sup>4</sup> 70	80	<sup>4</sup> 80	90	<sup>4</sup> 80	90	40	40	45	35	35	35
	30 kW	Electric Heat	<sup>4</sup> 90	100	<sup>4</sup> 100	110	<sup>4</sup> 100	125	50	60	60	40	45	45
	45 kW	Electric Heat	150	150	150	150	<sup>4</sup> 150	175	80	80	80	60	60	70
	60 kW	Electric Heat	<sup>4</sup> 150	175	<sup>4</sup> 150	175	<sup>4</sup> 150	175	80	80	90	70	70	70
<sup>3</sup> Minimum Circuit Ampacity	Unit+ 15 kW	Electric Heat	58	58	61	61	67	67	27	29	33	22	23	26
	22.5 kW	Electric Heat	69	78	72	81	80	89	39	40	44	31	32	35
	30 kW	Electric Heat	88	100	92	104	100	112	50	52	55	40	41	44
	45 kW	Electric Heat	127	145	131	149	139	157	72	74	78	58	60	62
	60 kW	Electric Heat	135	154	139	158	146	166	77	79	82	62	63	66
<sup>2</sup> Maximum Overcurrent Protection	Unit+ 15 kW	Electric Heat and (2) 0.5 HP Power Exhaust	80	80	80	80	80	80	30	35	35	25	25	30
	22.5 kW	Electric Heat and (2) 0.5 HP Power Exhaust	<sup>4</sup> 80	90	<sup>4</sup> 80	90	<sup>4</sup> 90	100	40	45	45	35	35	40
	30 kW	Electric Heat and (2) 0.5 HP Power Exhaust	<sup>4</sup> 100	110	<sup>4</sup> 100	110	<sup>4</sup> 110	125	60	60	60	45	45	50
	45 kW	Electric Heat and (2) 0.5 HP Power Exhaust	150	150	<sup>4</sup> 150	175	<sup>4</sup> 150	175	80	80	80	60	70	70
	60 kW	Electric Heat and (2) 0.5 HP Power Exhaust	<sup>4</sup> 150	175	<sup>4</sup> 150	175	<sup>4</sup> 150	175	80	80	90	70	70	70
<sup>3</sup> Minimum Circuit Ampacity	Unit+ 15 kW	Electric Heat and (2) 0.5 HP Power Exhaust	61	61	64	64	70	70	29	31	34	23	25	28
	22.5 kW	Electric Heat and (2) 0.5 HP Power Exhaust	72	81	76	85	84	93	40	42	45	32	34	37
	30 kW	Electric Heat and (2) 0.5 HP Power Exhaust	92	104	96	108	103	115	51	53	57	41	43	46
	45 kW	Electric Heat and (2) 0.5 HP Power Exhaust	131	149	135	153	142	160	74	76	79	60	61	64
	60 kW	Electric Heat and (2) 0.5 HP Power Exhaust	139	158	143	162	150	169	78	80	84	63	65	67

**ELECTRIC HEAT ACCESSORIES**

Unit Fuse Block	Unit Only	10Z42	10Z42	10Z42	10Z42	10Z42	10Z42	10Z42	10Z39	10Z39	10Z40	10Z39	10Z39	10Z39
	Unit + Power Exhaust	10Z42	10Z42	10Z42	10Z42	10Z42	10Z42	10Z42	10Z40	10Z40	10Z40	10Z39	10Z39	10Z39

NOTE - All units have a minimum Short Circuit Current Rating (SCCR) of 5000 amps.

<sup>1</sup> Extremes of operating range are plus and minus 10% of line voltage.

<sup>2</sup> HACR type breaker or fuse.

<sup>3</sup> Refer to National or Canadian Electrical Code manual to determine wire, fuse and disconnect size requirements.

<sup>4</sup> Factory installed circuit breaker not available.

## ELECTRIC HEAT CAPACITIES

Volts Input	7.5 kW			15 kW			22.5 kW			30 kW			45 kW			60 kW		
	kW Input	Btuh Output	No. of Stages	kW Input	Btuh Output	No. of Stages	kW Input	Btuh Output	No. of Stages	kW Input	Btuh Output	No. of Stages	kW Input	Btuh Output	No. of Stages	kW Input	Btuh Output	No. of Stages
208	5.6	19,100	1	11.3	38,600	1	16.9	57,700	2	22.5	76,800	2	33.8	115,300	2	45.0	153,600	2
220	6.3	21,500	1	12.6	43,000	1	18.9	64,500	2	25.2	86,000	2	37.8	129,000	2	50.4	172,000	2
230	6.9	23,600	1	13.8	47,100	1	20.7	70,700	2	27.5	93,900	2	41.3	141,000	2	55.1	188,000	2
240	7.5	25,600	1	15.0	51,200	1	22.5	76,800	2	30.0	102,400	2	45.0	153,600	2	60.0	204,800	2
440	6.9	21,500	1	12.6	43,000	1	18.9	64,500	2	25.2	86,000	2	37.8	129,000	2	50.4	172,000	2
460	6.9	23,600	1	13.8	47,100	1	20.7	70,700	2	27.5	93,900	2	41.3	141,000	2	55.1	188,000	2
480	7.5	25,600	1	15.0	51,200	1	22.5	76,800	2	30.0	102,400	2	45.0	153,600	2	60.0	204,800	2
550	6.3	21,500	1	12.6	43,000	1	18.9	64,500	2	25.2	86,000	2	37.8	129,000	2	50.4	172,000	2
575	6.9	23,600	1	13.8	47,100	1	20.7	70,700	2	27.5	93,900	2	41.3	141,000	2	55.1	188,000	2
600	7.5	25,600	1	15.0	51,200	1	22.5	76,800	2	30.0	102,400	2	45.0	153,600	2	60.0	204,800	2

## UNIT CLEARANCES

### UNIT WITH ECONOMIZER

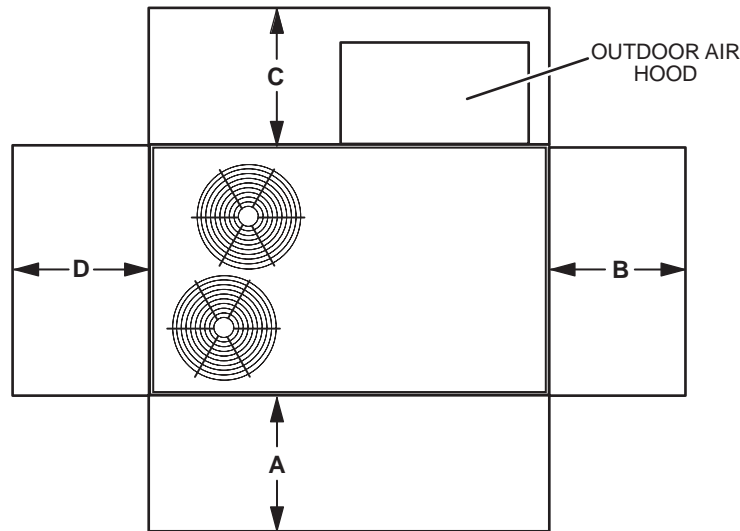

<sup>1</sup> Unit Clearance	A		B		C		D		Top Clearance
	in.	mm	in.	mm	in.	mm	in.	mm	
Service Clearance	60	1524	36	914	36	914	60	1524	Unobstructed
Minimum Operation Clearance	36	914	36	914	36	914	36	914	

NOTE - Entire perimeter of unit base requires support when elevated above the mounting surface.

<sup>1</sup> Service Clearance - Required for removal of serviceable parts.

Minimum Operation Clearance - Required clearance for proper unit operation.

## OUTDOOR SOUND DATA

Unit Model Number	Octave Band Sound Power Levels dBA, re 10 <sup>-12</sup> Watts - Center Frequency - Hz							<sup>1</sup> Sound Rating Number dBA
	125	250	500	1000	2000	4000	8000	
092, 102 and 120	72	74	79	80	76	70	63	84
150	76	81	87	86	80	77	76	91

<sup>1</sup> Sound Rating Number according to ARI Standard 270-2008. Sound Rating Number is the overall A-Weighted Sound Power Level, (LWA), dB (100 Hz to 10,000 Hz).

**WEIGHT DATA**

Model Number	Net		Shipping	
	lbs.	kg	lbs.	kg
092S Base Unit	854	387	939	426
092S Max. Unit	1011	459	1096	497
102S Base Unit	874	396	959	435
102S Max. Unit	1031	468	1116	506
120S4B Base Unit	1106	501	1191	540
120S4B Max. Unit	1270	576	1355	615
120S4M Base Unit	914	415	999	453
120S4M Max. Unit	1078	489	1163	528
150S Base Unit	1004	455	1089	494
150S Max. Unit	1168	530	1253	568

**OPTIONS / ACCESSORIES**

Model Number	Shipping Weight	
	lbs.	kg
<b>CABINET</b>		
Coil/Hail Guard	50	23
<b>CEILING DIFFUSERS</b>		
<b>Step-Down</b>		
RTD11-95S	118	54
RTD11-135S	135	61
RTD11-185S	168	76
<b>Flush</b>		
FD11-95S	118	54
FD11-135S	135	61
FD11-185S	168	76
<b>ECONOMIZER / OUTDOOR AIR / EXHAUST</b>		
<b>Economizer</b>		
Downflow with Barometric Relief Dampers and Hoods	90	41
Horizontal with Barometric Relief Dampers and Hoods	95	43
Horizontal Low Profile Barometric Relief Dampers with Hood	8	4
<b>Outdoor Air Dampers</b>		
Outdoor Air Damper Section with Hood - Automatic	44	20
Outdoor Air Damper Section with Hood - Manual	27	12
<b>Power Exhaust</b>		
Downflow	60	27
Horizontal	41	19
<b>ELECTRIC HEAT</b>		
7.5 kW	90	41
15 kW	90	41
22.5 kW	90	41
30 kW	90	41
45 kW	90	41
60 kW	90	41
<b>MSAV® (MULTI-STAGE AIR VOLUME) SUPPLY AIR BLOWER OPTION</b>		
Variable Frequency Drive (VFD) and associated components	10	5
<b>ROOF CURBS</b>		
<b>Hybrid Roof Curbs, Downflow</b>		
8 in. height	79	36
14 in. height	104	47
18 in. height	120	54
24 in. height	145	66
<b>PACKAGING</b>		
LTL Packaging (less than truck load)	105	48

# DIMENSIONS - UNIT

Model No.	CORNER WEIGHTS														CENTER OF GRAVITY									
	AA				BB				CC				DD				EE				FF			
	Base		Max.		Base		Max.		Base		Max.		Base		Max.		Base		Max.		Base		Max.	
	lbs.	kg	lbs.	kg	lbs.	kg	lbs.	kg	lbs.	kg	lbs.	kg	lbs.	kg	lbs.	kg	in.	mm	in.	mm	in.	mm	in.	mm
092S	244	111	287	130	181	82	227	103	182	83	220	100	247	112	278	126	47.5	1207	48.5	1232	25.5	648	26.5	673
102S	250	113	293	133	185	84	231	105	187	85	224	102	252	114	283	128	47.5	1207	48.5	1232	25.5	648	26.5	673
120S	262	119	306	139	193	88	242	110	195	88	234	106	264	120	296	134	47.5	1207	48.5	1232	25.5	648	26.5	673
150S	287	130	332	150	212	96	262	119	214	97	254	115	290	131	321	145	47.5	1207	48.5	1232	25.5	648	26.5	673

Base Unit - The unit with NO OPTIONS.

Max. Unit - The unit with ALL OPTIONS Installed. (Economizer, etc.)

## BOTTOM POWER ENTRY

Holes required for Optional Bottom Power Entry Kit

	Threaded Conduit Fittings (Provided in Kit)	Wire Use	Hole Diameter Required in Unit Base (Max.)
<b>A</b>	<sup>1</sup> 1/2	ACC	7/8 (23)
<b>B</b>	1/2	24V	7/8 (23)
<b>C</b>	1-1/4	POWER	1-3/4 (44)

<sup>1</sup> Field provided.

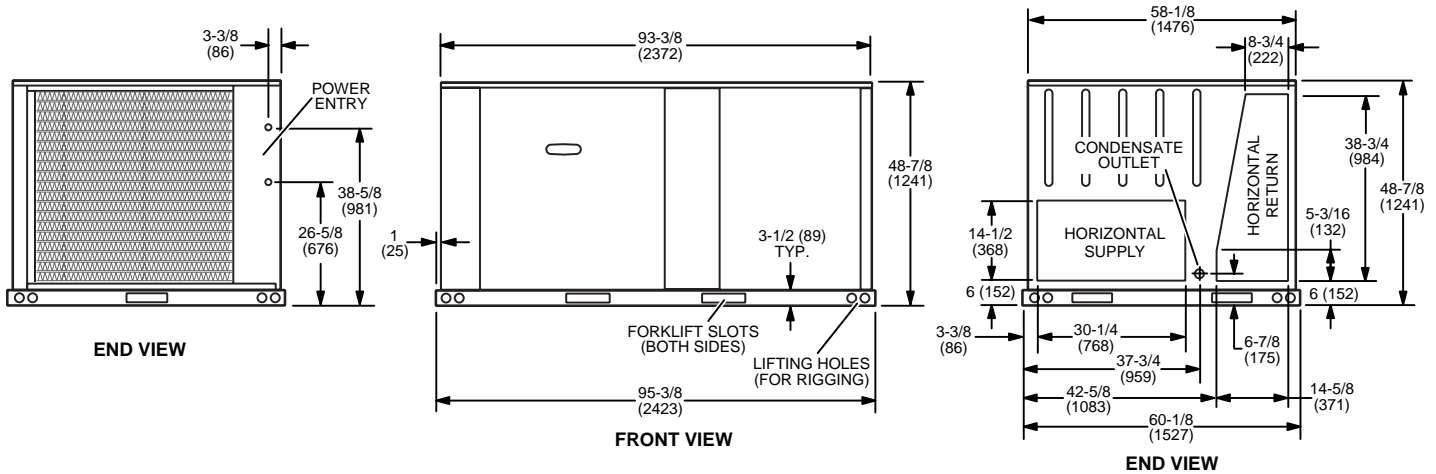
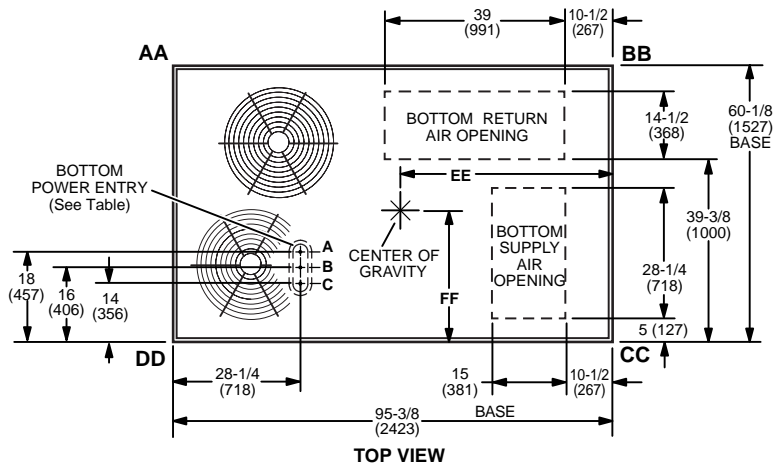

## DIMENSIONS - ACCESSORIES

### OUTDOOR AIR HOOD DETAIL FOR OPTIONAL DOWNFLOW ECONOMIZER (Downflow Applications)

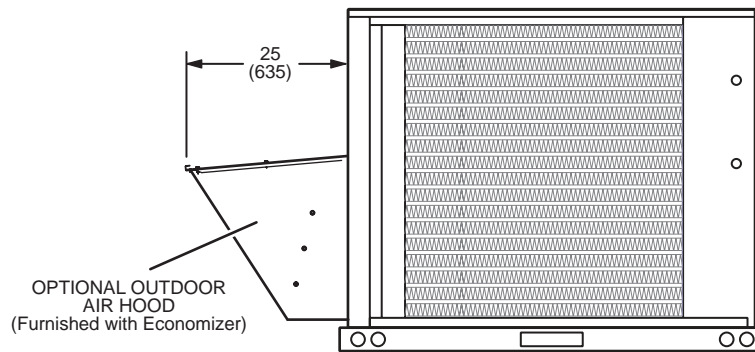

END VIEW

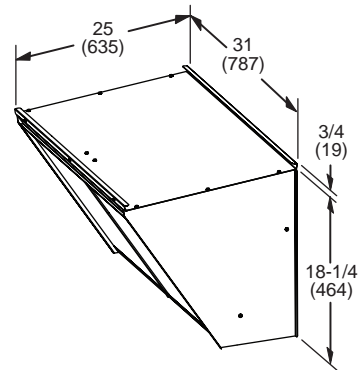

### OUTDOOR AIR DAMPER HOOD DETAIL FOR OPTIONAL MANUAL OR MOTORIZED OUTDOOR AIR DAMPERS (Downflow or Horizontal Applications)

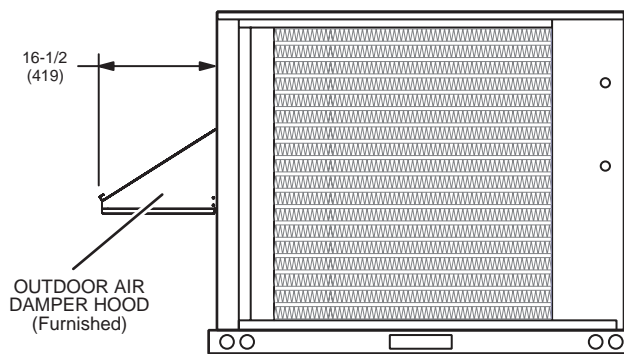

END VIEW

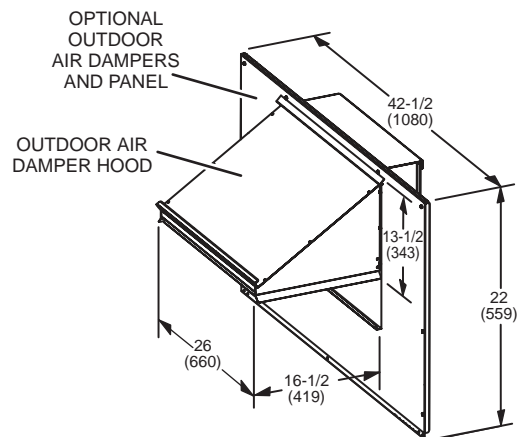

## DIMENSIONS - ACCESSORIES

### OUTDOOR AIR HOOD DETAIL WITH OPTIONAL HORIZONTAL ECONOMIZER AND BAROMETRIC RELIEF DAMPERS (Horizontal Applications)

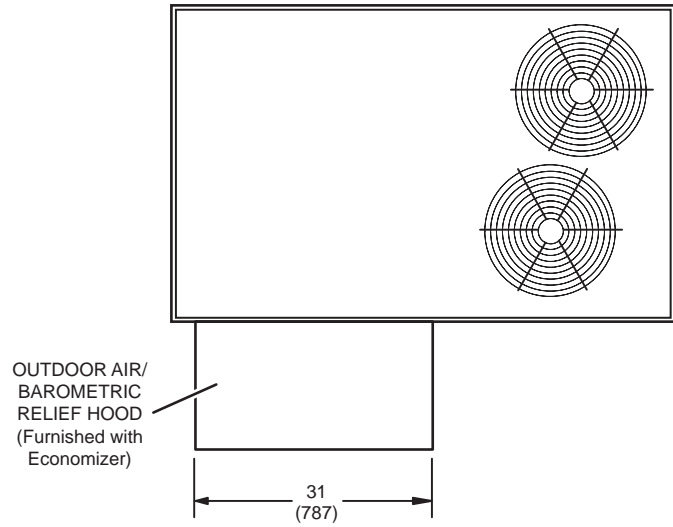

**TOP VIEW**

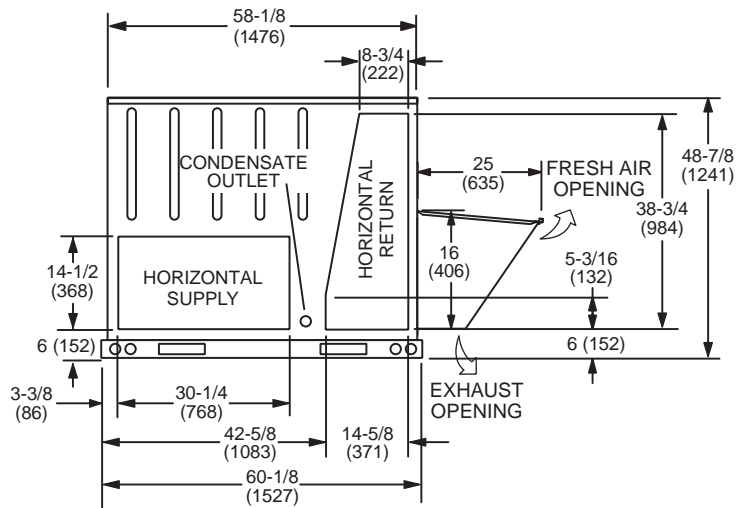

**END VIEW**

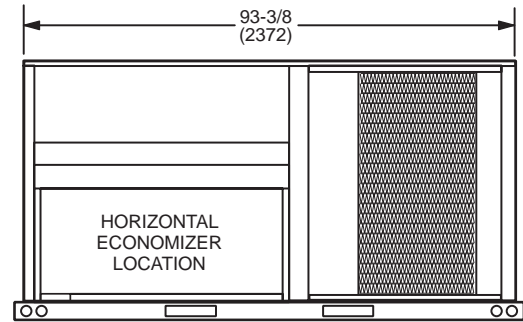

**BACK VIEW**

Note - Supply and Return Air Ducts must be supported.

# DIMENSIONS - ACCESSORIES

## HYBRID CURBS - DOUBLE DUCT OPENING

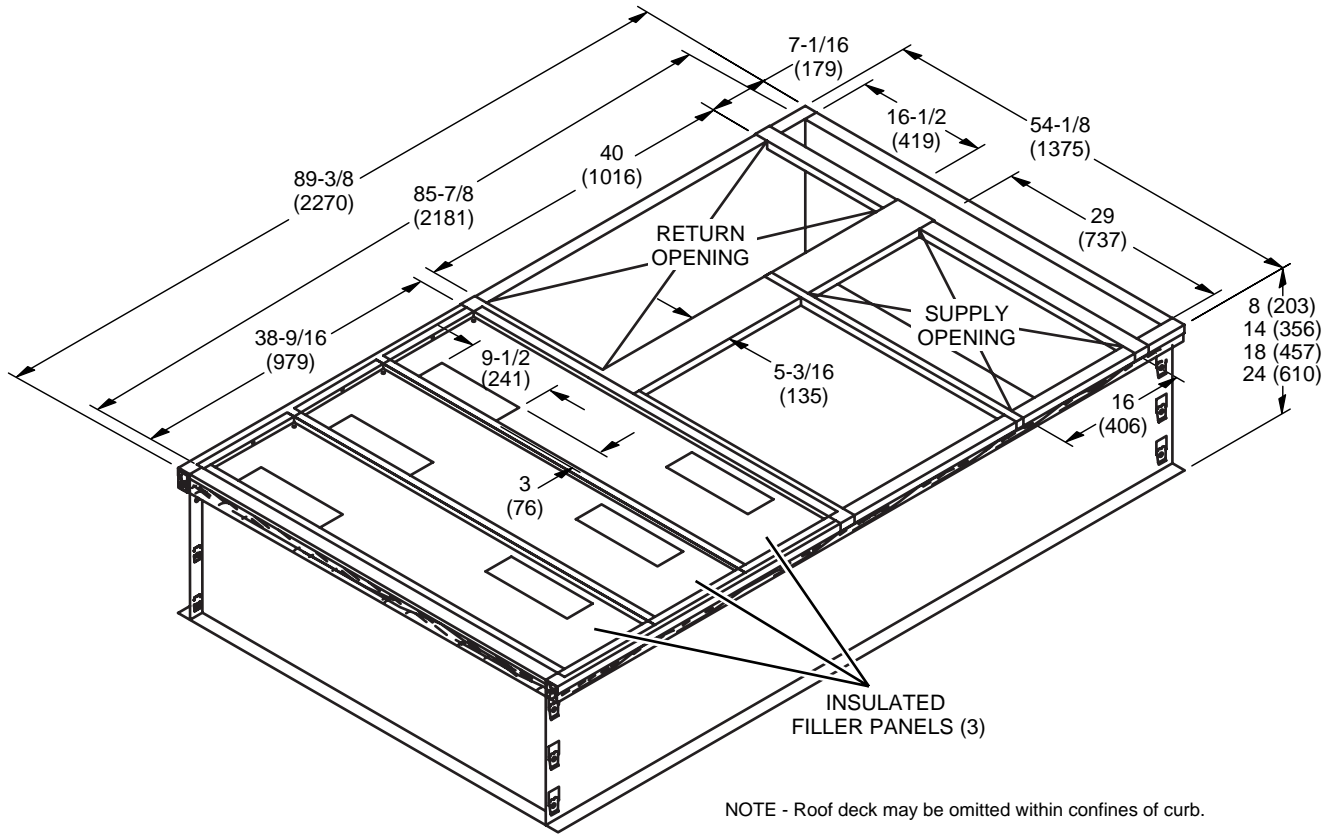

**TYPICAL FLASHING DETAIL FOR ROOF CURB**

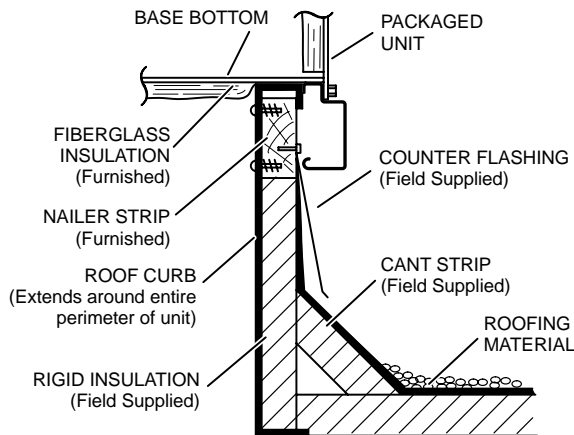

**DETAIL ROOF CURB**

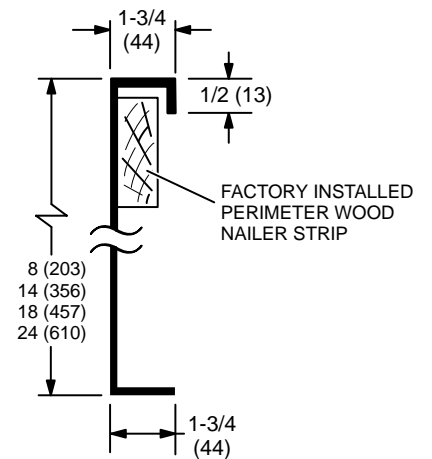

## DIMENSIONS - ACCESSORIES

### COMBINATION CEILING SUPPLY AND RETURN DIFFUSERS

#### STEP-DOWN CEILING DIFFUSER

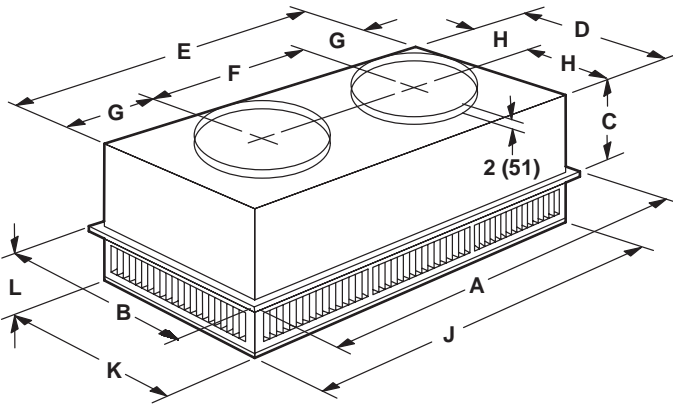

#### FLUSH CEILING DIFFUSER

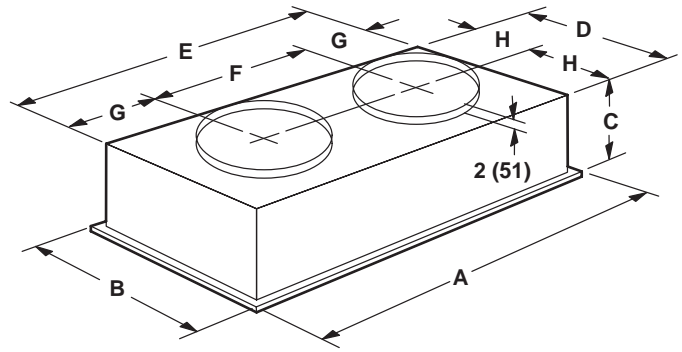

Model Number		RTD11-95S
A	in.	47-5/8
	mm	1159
B	in.	29-5/8
	mm	752
C	in.	14-3/8
	mm	365
D	in.	27-1/2
	mm	699
E	in.	45-1/2
	mm	1158
F	in.	22-1/2
	mm	572
G	in.	11-1/2
	mm	292
H	in.	13-3/4
	mm	349
J	in.	45-1/2
	mm	1156
K	in.	27-1/2
	mm	699
L	in.	8-1/8
	mm	206
Duct Size	in.	20 round
	mm	508 round

Model Number		FD11-95S
A	in.	47-5/8
	mm	1159
B	in.	29-5/8
	mm	752
C	in.	16-5/8
	mm	422
D	in.	27
	mm	686
E	in.	45
	mm	1143
F	in.	22-1/2
	mm	572
G	in.	11-1/4
	mm	286
H	in.	13-1/2
	mm	343
Duct Size	in.	20 round
	mm	508 round



## DIMENSIONS - ACCESSORIES

### COMBINATION CEILING SUPPLY AND RETURN DIFFUSERS

#### STEP-DOWN CEILING DIFFUSER

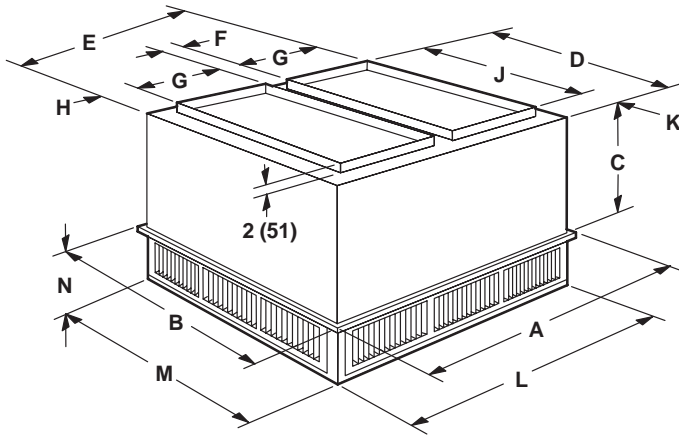

#### FLUSH CEILING DIFFUSER

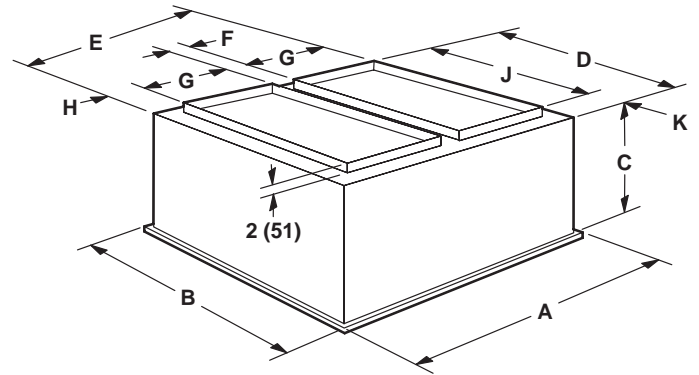

Model Number		RTD11-135S	RTD11-185S
A	in.	47-5/8	47-5/8
	mm	1210	1210
B	in.	35-5/8	47-5/8
	mm	905	1210
C	in.	20-5/8	24-5/8
	mm	524	625
D	in.	33-1/2	45-1/2
	mm	851	1156
E	in.	45-1/2	45-1/2
	mm	1156	1156
F	in.	4-1/2	4-1/2
	mm	114	114
G	in.	18	18
	mm	457	457
H	in.	2-1/2	2-1/2
	mm	64	64
J	in.	28	36
	mm	711	914
K	in.	2-3/4	4-3/4
	mm	70	121
L	in.	45-1/2	45-1/2
	mm	1156	1156
M	in.	33-1/2	45-1/2
	mm	851	1156
N	in.	9-1/8	10-1/8
	mm	232	257
Duct Size	in.	18 x 28	18 x 36
	mm	457 x 711	457 x 914

Model Number		FD11-135S	FD11-185S
A	in.	47-5/8	47-5/8
	mm	1210	1210
B	in.	35-5/8	47-5/8
	mm	905	1210
C	in.	23-1/4	29-1/4
	mm	591	743
D	in.	33	45
	mm	838	1143
E	in.	45	45
	mm	1143	1143
F	in.	4-1/2	4-1/2
	mm	114	114
G	in.	18	18
	mm	457	457
H	in.	2-1/4	2-1/4
	mm	57	57
J	in.	28	36
	mm	711	914
K	in.	2-1/2	4-1/2
	mm	64	114
Duct Size	in.	18 x 28	18 x 36
	mm	457 x 711	457 x 914





## REVISIONS

Section	Description
Specifications	Revised the IEER data for ZCA150S4M.



Visit us at [www.lennox.com](http://www.lennox.com)

For the latest technical information, [www.lennoxcommercial.com](http://www.lennoxcommercial.com)

Contact us at 1-800-4-LENNOX

NOTE - Due to Lennox' ongoing commitment to quality, Specifications, Ratings and Dimensions subject to change without notice and without incurring liability. Improper installation, adjustment, alteration, service or maintenance can cause property damage or personal injury. Installation and service must be performed by a qualified installer and servicing agency.

©2019 Lennox Industries, Inc.