



**COMMERCIAL  
PRODUCT SPECIFICATIONS**

Bulletin No. 210724  
March 2021  
Supersedes April 2019



**RAIDER®**  
Value Without Compromise®



**ASHRAE 90.1  
COMPLIANT**

**7.5 to 10 Tons**  
**Net Cooling Capacity - 87,000 to 118,000 Btuh**  
**Net Heating Capacity - 89,000 to 116,000 Btuh**  
**Optional Electric Heat - 7.5 to 60 kW**

**MODEL NUMBER IDENTIFICATION**

**Z H A 1 2 0 S 4 B N 1 Y**

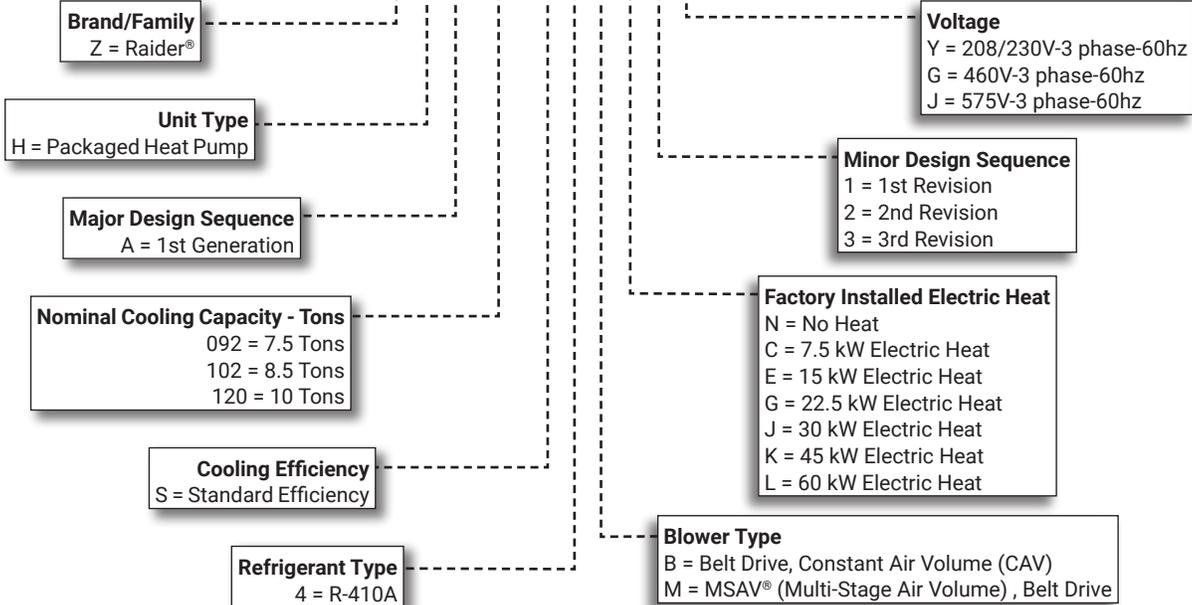

## FEATURE HIGHLIGHTS

Raider® rooftop units from Lennox Commercial are the new standard for cost efficient reliable, efficient rooftop units built for long-lasting performance that can significantly improve indoor environments.

1. Scroll Compressors
2. Copper Tube Coil Construction
3. Outdoor Coil Fans
4. Heavy Gauge Steel Cabinet
5. Supply Air Blower
6. Electric Heat (option)

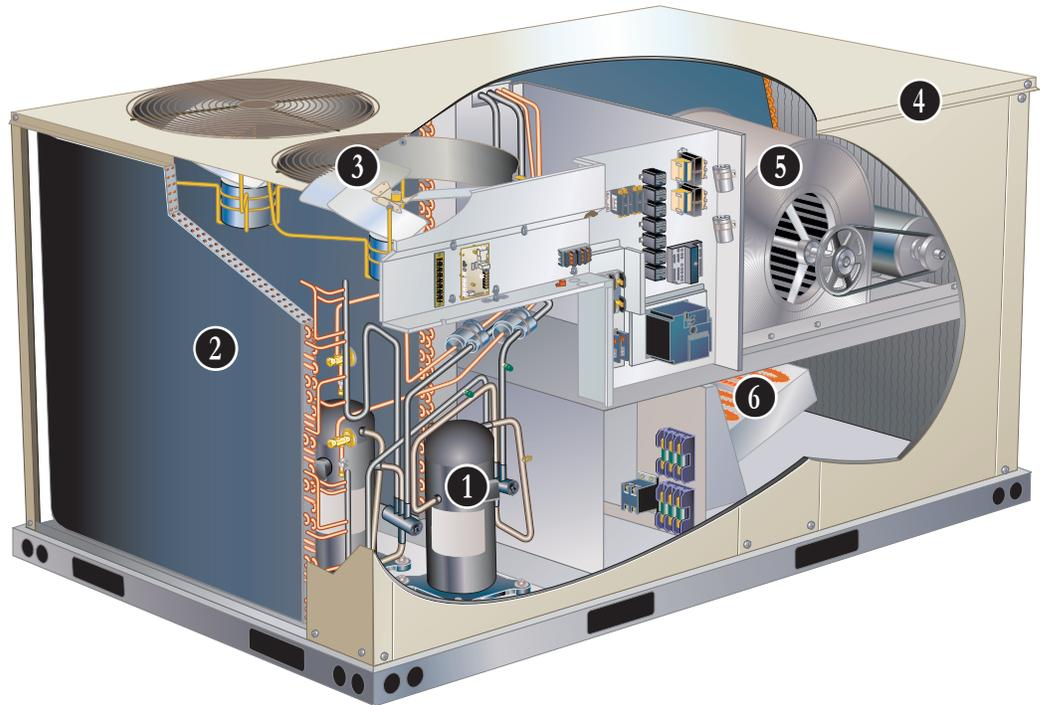

## CONTENTS

Approvals and Warranty . . . . .	3
Blower Data . . . . .	21
Dimensions - Accessories . . . . .	31
Dimensions - Unit . . . . .	30
Electrical/Electric Heat Data . . . . .	25
Electric Heat Capacities . . . . .	28
Features and Benefits . . . . .	3
Model Number Identification. . . . .	1
Options / Accessories . . . . .	10
Outdoor Sound Data . . . . .	28
Ratings . . . . .	15
Specifications . . . . .	13
Weight Data . . . . .	29

## APPROVALS AND WARRANTY

### APPROVALS

- AHRI Standard 340/360 certified
- ETL Intertek listed
- Unit and components ETL, NEC, and CEC bonded for grounding to meet safety standards for servicing
- All models are ASHRAE 90.1-2010 energy efficiency compliant and meet or exceed requirements of Section 6.8
- MSAV models meet California Code of Regulations, Title 24 and ASHRAE 90.1-2010 Section 6.4.3.10 requirements for staged airflow
- ISO 9001 Registered Manufacturing Quality System

### WARRANTY

- Compressors - Limited five years
- High Performance Economizers (optional) - Limited five years
- All other covered components - Limited one year

## FEATURES AND BENEFITS

### COOLING SYSTEM

- Designed to maximize sensible and latent cooling performance at design conditions
- System can operate from 30°F to 125°F without any additional controls

#### **R-410A Refrigerant**

- Non-chlorine based
- Ozone friendly

#### **1 Scroll Compressors**

- Scroll compressors on all models for high performance, reliability and quiet operation
- Resiliently mounted on rubber grommets for quiet operation

#### **Refrigerant Metering Orifice**

- Accurately meters refrigerant in system
- Refrigerant control is accomplished by exact sizing of refrigerant metering orifice

#### **Filter/Driers**

- High capacity filter/drier protects the system from dirt and moisture

#### **Reversing Valve**

- 4-way interchange reversing valve effects a rapid change in direction of refrigerant flow resulting in quick changeover from cooling to heating and vice versa

#### **Defrost Control**

- Provides a defrost cycle, if needed, every 30 or 60 or 90 minutes (adjustable) of compressor "on" time at outdoor coil temperature below 35°F
- Pressure and temperature switches terminate defrost cycle

#### **High Pressure Switches**

- Protects the compressor from overload conditions
- Auto-reset

#### **Coil Construction**

- 2** • Copper tube construction
- Enhanced rippled-edge aluminum fins
- Flared shoulder tubing connections
- Silver soldered construction
- Factory leak tested

#### **Indoor Coil**

- Cross row circuiting with rifled tubing optimizes both sensible and latent cooling capacity

#### **Condensate Drain Pan**

- Plastic pan, sloped to meet drainage requirements of ASHRAE 62.1
- Side drain connections

#### **Outdoor Coil Fan Motors**

- Thermal overload protected
- Totally enclosed
- Permanently lubricated ball bearings
- Shaft up
- Wire basket mount

#### **3 Outdoor Coil Fans**

- PVC coated fan guard furnished

#### **Required Selections**

##### **Cooling Capacity**

- Specify nominal cooling capacity

##### **Options/Accessories**

##### **Field Installed**

##### **Condensate Drain Trap**

- Available in copper or PVC

##### **Drain Pan Overflow Switch**

- Monitors condensate level in drain pan
- Shuts down unit if drain becomes clogged

## FEATURES AND BENEFITS

### COOLING SYSTEM (continued)

#### Options/Accessories (continued)

### Field Installed (continued)

#### Low Ambient Kit

- Cycles the outdoor fan while allowing compressor operation in the cooling cycle
- Intermittent fan operation allows the system to operate without icing the indoor coil and losing capacity
- Designed for use in ambient temperatures no lower than 0°F

### CABINET

#### Construction

- 4 • Heavy-gauge steel panels
- Full perimeter heavy-gauge galvanized steel base rail
- Base rails have rigging holes
- Three sides of the base rail have forklift slots
- Raised edges around duct and power entry openings in the bottom of the unit for water protection

#### Airflow Choice

- Units are shipped in downflow (vertical) return air flow configuration

#### Duct Flanges

- Provided for horizontal duct attachment.

#### Power Entry

- Electrical lines can be brought through the unit base or through horizontal access knock-outs

**NOTE** - Optional Bottom Power Entry Kit is available.

#### Exterior Panels

- Constructed of heavy-gauge, galvanized steel
- Two-layer enamel paint finish

#### Insulation

- Fully insulated with non-hygroscopic fiberglass insulation (conditioned areas)

#### Access Panels

- Filter section
- Blower/heating section
- Compressor/controls section
- Recessed handles for easy service access

#### Options/Accessories

### Factory Installed

#### Corrosion Protection

- Completely flexible immersed coating
- Electrodeposited dry film process (AST ElectroFin E-Coat)
- Meets Mil Spec MIL-P-53084, ASTM B117 Standard Method Salt Spray Testing
- Indoor Corrosion Protection:
  - Coated coil
- Outdoor Corrosion Protection:
  - Coated coil

### Field Installed

#### Combination Coil/Hail Guards

- Heavy gauge steel frame
- Painted to match cabinet
- Expanded metal mesh protects outdoor coil

### BLOWER

A wide selection of supply air blower options are available to meet a variety of airflow requirements.

#### Motor

- Overload protected
- Ball bearings
- Belt drive motors are offered on all models and are available in several different sizes to maximize air performance

### 5 Supply Air Blower

- Forward curved blades
- Double inlet
- Blower wheel statically and dynamically balanced
- Ball bearings
- Adjustable pulley (allows speed change)

#### Required Selections

#### Select Constant Air Volume (CAV) or MSAV® (Multi-Stage Air Volume) Supply Air Blower Option

- Order blower motor horsepower and drive kit number required when base unit is ordered
- See Drive Kit Specifications Table

#### CAV Operation

- Supply air blower provides a constant volume of air

#### MSAV Operation

- Units utilize a Variable Frequency Drive (VFD) to stage the supply air blower airflow
- The VFD alters the frequency and voltage of the power supply to the blower to control blower speed
- The supply air blower has two speeds:
  - Low speed for part-load cooling operation

**NOTE** - Low speed is 67% of high speed

- High speed for full load cooling and all heat modes
- Full speed blower operation is set by adjusting the motor pulley to deliver the desired air volume
- The ventilation speed is selectable between high and low speed

**NOTE** - Part load airflow in cooling mode on MSAV® units should not be set below 220 cfm/nominal full load ton to reduce the risk of evaporator coil freeze-up.

- The VFD has an operational range of -40 to 125°F outdoor air ambient temperature
- Lower operating costs are obtained when the blower is operated on lower speeds

## FEATURES AND BENEFITS

### **BLOWER (continued)**

#### **MSAV Sequence of Operation**

- Blower operates in low speed for mechanical cooling mode (Y1), ventilation mode (G), or free cooling mode
- Blower operates in high speed for any other mode - mechanical cooling (Y1+Y2), free cooling + Y2 or heating (W1 and W1+W2)
- Economizer damper minimum position is fully closed in unoccupied mode
- In occupied mode, the economizer damper minimum position is determined by the setting of the economizer control

**NOTE** - Two-minimum fresh-air settings are only available on MSAV® with the High Performance Economizer option.

**NOTE** - Units equipped a Variable Frequency Drive (VFD) are designed to operate on balanced, three-phase power. Operating units on unbalanced three-phase power will reduce the reliability of all electrical components in the unit. Unbalanced power is a result of the power delivery system supplied by the local utility company. Factory-installed inverters are sized to drive blower motors with an equivalent current rating using balanced three-phase power. If unbalanced three-phase power is supplied; the installer must replace the existing factory-installed inverter with an inverter that has a higher current rating to allow for the imbalance. Refer to the installation instructions for additional information and replacement information.

### **CONTROLS**

#### **Unit Control**

- All control voltage is provided via a 24V (secondary) transformer with built-in circuit breaker protection
- **Heat/Cool Staging** - Capable of up to 2 heat / 2 cool staging with a third party DDC control system or thermostat
- **Low Voltage Terminal Block** - Provides screw terminal connections for thermostat or controller wiring
- **Night Setback Mode** - Saves energy by closing outdoor air dampers and operating supply fan on thermostat demand only

#### **Options/Accessories**

#### **Field Installed**

##### **Smoke Detectors**

**NOTE** - Smoke detectors are not furnished and must be field supplied.

#### **Commercial Control Systems**

##### **L Connection® Network**

- Complete building automation control system for single or multi-zone applications
- Options include local interface, software for local or remote communication, and hardware for networking other control functions

- See L Connection Network Product Specifications Bulletin for details

#### **Thermostats**

- Control system and thermostat options, see page 9

### **ELECTRICAL**

#### **Marked & Color-Coded Wiring**

- All electrical wiring is color-coded and marked to identify which components it is connecting

#### **Electrical Plugs**

- Positive connection electrical plugs are used to connect common accessories or maintenance parts for easy removal or installation

#### **Required Selections**

##### **Voltage Choice**

- Specify when ordering base unit

##### **Options/Accessories**

#### **Field Installed**

##### **6 Electric Heat**

- Helix wound nichrome elements
- Individual element limit controls
- Wiring harness
- See Options / Accessories tables for ordering information

**NOTE** - Unit Fuse Block is required and must be ordered separately. See Electrical / Electric Heat tables for ordering information.

#### **Bottom Power Entry Kit**

- Reduces the number of penetrations in the roof
- Includes bulkhead connectors to provide power and control wiring routing through the roof curb

### **INDOOR AIR QUALITY**

#### **Air Filters**

- Disposable 2 inch filters furnished as standard

#### **Options/Accessories**

#### **Field Installed**

##### **Healthy Climate® High Efficiency Air Filters**

- Disposable MERV 8 or MERV 13 (Minimum Efficiency Reporting Value based on ASHRAE 52.2) efficiency 2 inch pleated filters

##### **Replacement Filter Media Kit With Frame**

- Replaces existing pleated filter media
- Includes washable metal mesh screen and metal frame with clip for holding replaceable non-pleated filter

##### **Indoor Air Quality (CO<sub>2</sub>) Sensors**

- Monitors CO<sub>2</sub> levels, reports to the Unit Controller which adjusts economizer dampers as needed

### ECONOMIZER

#### **Factory or Field Installed**

**NOTE** - Downflow Economizer is factory or field installed.  
Horizontal Economizer is field installed only.

#### Economizer

##### (Standard and High Performance Common Features)

- Downflow or Horizontal models with Barometric Relief Dampers and Hoods
- Barometric Relief Dampers allow relief of excess air
- Aluminum blade dampers prevent blow back and outdoor air infiltration during off cycle
- Exhaust hood with bird screen furnished

**NOTE** - Outdoor Air and Barometric Relief Exhaust Hoods are included when economizer is factory installed and are furnished with economizer when ordered for field installation.

- Occupied/Unoccupied mode with field furnished setback thermostat
- Demand Control Ventilation (DCV) ready using optional CO<sub>2</sub> sensors
- Single temperature control is furnished with Economizer
- Outdoor air temperature sensor enables Economizer if the outdoor temperature is less than the setpoint of the control

#### Standard Economizer Features (Not for Title 24)

- Gear-driven action
- Return air and outdoor air dampers
- Plug-in connections to unit
- Nylon bearings
- Neoprene seals
- 24-volt
- Fully-modulating spring return motor

#### Standard Economizer Control Module

The Standard Economizer Control Module can be adjusted to operate based on outdoor air temperatures.



#### Economizer Controls:

- **Damper Minimum Position** - Can be set lower than traditional minimum air requirements resulting in cost savings
- **IAQ Sensor** - Signals dampers to modulate and maintain 55°F when CO<sub>2</sub> is higher than the CO<sub>2</sub> setpoint
- **Demand Control Ventilation (DCV) LED** - A steady green Demand Control Ventilation LED indicates the IAQ reading is higher than setpoint and requires more fresh air
- **Free Cool LED** - A steady green LED indicates outdoor air is suitable for free cooling
- Free Cooling runs when outdoor air temperature is lower than the set temperature on the economizer control

**NOTE** - The Free Cooling default setting for outdoor air temperature sensor is 55°F.

### **ECONOMIZER (continued)**

#### **Factory or Field Installed (continued)**

##### **High Performance Economizer Features**

- Approved for California Title 24 building standards
- Low leakage dampers are Air Movement and Control Association International (AMCA) Class 1A Certified - Maximum 3 CFM per sq. ft. leakage at 1 in. w.g.
- ASHRAE 90.1-2010 compliant
- Gear-driven action
- High torque 24-volt fully-modulating spring return damper motor
- Return air and outdoor air dampers
- Plug-in connections to unit
- Stainless steel bearings
- Enhanced thermoplastic vulcanizate (TPV) seals
- Flexible stainless steel jamb seals minimize air leakage

**NOTE** - High Performance Economizers are not approved for use with enthalpy controls in Title 24 applications.

**NOTE** - The free cooling setpoint for Title 24 applications must be set based on the Climate Zone where the system is installed. See Section 140.4 "Prescriptive Requirements for Space Conditioning Systems" of the California Energy Commission's 2013 Building Energy Efficiency Standards.

##### **High Performance Economizer Control Module**

- Module provides inputs and outputs to control economizer based on parameter settings
- Module automatically detects sensors by polling to determine which sensors are installed in system
- Module displays any alarm messages (fault detection and diagnostics) as an aid in troubleshooting
- Non-volatile memory retains parameter settings in case of power failure
- Keypad with four navigation buttons and LCD screen is furnished for setting economizer parameters
  - Menu Up/Exit  button returns to the main menu
  - Arrow Up  button moves to the previous or next parameter within the selected menu
  - Arrow Down  button moves to the next parameter within the selected menu
  - Select (enter)  button confirms parameter selection



##### **Main Menu Structure:**

- STATUS (economizer and system operation status)
- SETPOINTS (settings for various setpoint parameters)
- SYSTEM SETUP (settings/information about the system)
- ADVANCED SETUP (freeze protection, CO<sub>2</sub> settings, stage 3 delay and additional calibration settings)
- CHECKOUT (damper positions)
- ALARMS (output signal that can be configured for remote alarm monitoring)

**NOTE** - Refer to Installation Instructions for complete setup information and menu parameters available.

#### **Field Installed**

##### **Single Enthalpy Temperature Control (Not for Title 24)**

- Outdoor air enthalpy sensor enables Economizer if the outdoor enthalpy is less than the setpoint of the control

##### **Differential Enthalpy Control (Not for Title 24)**

- Order two Single Enthalpy Controls
- One is field installed in the return air section, the other in the outdoor air section
- Allows the Economizer control board to select between outdoor air or return air, whichever has lower enthalpy

## OPTIONS / ACCESSORIES

### **EXHAUST**

#### **Field Installed**

##### **Horizontal Low Profile Barometric Relief Dampers**

- For use when unit is configured for horizontal applications in a reduced space requiring an economizer
- Allows relief of excess air
- Aluminum blade dampers prevent blow back and outdoor air infiltration during off cycle
- Field installed in return air duct
- Exhaust hood with bird screen furnished

##### **Power Exhaust Fan**

- Installs internal to unit for downflow applications only with Economizer option
- Provides exhaust air pressure relief
- Interlocked to run when supply air blower is operating
- Fan runs when outdoor air dampers are 50% open (adjustable)
- Motor is overload protected
- Fan is 20 in. diameter
- Five blades
- One 1/3 hp motor

**NOTE** - Requires Economizer with Outdoor Air Hood and Barometric Relief Dampers.

### **OUTDOOR AIR**

#### **Field Installed**

##### **Outdoor Air Damper**

- Downflow or Horizontal
- Linked mechanical dampers
- 0 to 25% (fixed) outdoor air adjustable
- Installs in unit
- Includes outdoor air hood
- Automatic model features fully modulating spring return damper motor with plug-in connection
- Manual model features a slide damper

**NOTE** - Maximum mixed air temperature in cooling mode: 100°F.

### **ROOF CURBS**

#### **Field Installed**

##### **Hybrid Roof Curbs, Downflow**

- Nailer strip furnished; mates to unit
- US National Roofing Contractors approved
- Shipped knocked down
- Interlocking tabs fasten corners together; no tools required
- Can also be fastened together with furnished hardware
- Available in 8, 14, 18, and 24 inch heights

### **CEILING DIFFUSERS**

#### **Field Installed**

##### **(Flush or Step-Down)**

- White powder coat finish on diffuser face and grilles
- Insulated UL listed duct liner
- Diffuser box has collars for duct connection
- Step-down diffusers have double deflection blades
- Flush diffusers have fixed blades
- Provisions for suspending
- Internally sealed to prevent recirculation
- Removable return air grille
- Adapts to T-bar ceiling grids or plaster ceilings

##### **Transitions (Supply and Return)**

**NOTE** - Ceiling Diffuser Transitions are not furnished and must be field fabricated.



## OPTIONAL CONVENTIONAL TEMPERATURE CONTROL SYSTEMS

### ComfortSense® 7500 Commercial 7-Day Programmable Thermostat



- Four-Stage Heating / Two-Stage Cooling
- Universal Multi-Stage
- Intuitive Touchscreen Interface
- Automatic Changeover between Heating and Cooling
- Full Seven-Day Programming
- Four Time Periods Per Day
- Temperature and Humidity Control
- One-Touch Away Mode
- Holiday Scheduling
- Smooth Setback Recovery (SSR)
- Performance Reports
- Notifications/Reminders
- Economizer Relay Control
- Backlit Display
- Wallplate Furnished
- FDD, ASHRAE and IECC Compliant

### ComfortSense® 3000 Commercial 5-2 Day Programmable Thermostat



- Two-Stage Heating / Two-Stage Cooling
- Conventional Systems
- Intuitive Interface
- 5-2 Day Programming
- Program Hold
- Remote Indoor Temperature Sensing
- Smooth Setback Recovery (SSR)
- Economizer Relay Control
- Maintenance/Filter/Service Reminders
- Backlit Display
- Wallplate Furnished
- Simple Up and Down Temperature Control

### Bacnet Compatible Thermostat With Reheat Function



- 7-Day Programmable
- BTL listed MS/TP ensures compatibility with any BACnet system
- Built-in control programs for conventional and heat pump applications
- Conventional systems up to 3-stage heat and 3-stage cool
- Heat pumps with 1 or 2 compressors and up to 2-stage auxiliary heat
- On-board temperature and humidity sensor
- Multiple configurable inputs and outputs enable advanced control strategies
- Set-up Wizard enables rapid system configuration
- No special tools required for installation or commissioning
- Seven-day (2, 4 or 6 event) occupancy scheduling per day
- Backlit 5-inch LCD touchscreen

Description	Catalog No.
<b>ComfortSense® 7500 Commercial 7-Day Programmable Thermostat</b>	
CS7500 7-Day Thermostat	<b>17G74</b>
Sensors/	<sup>1</sup> Remote non-adjustable wall-mount 20k <b>47W36</b>
Accessories	<sup>1</sup> Remote non-adjustable wall-mount 10k <b>47W37</b>
	Remote non-adjustable discharge air (duct mount) <b>19L22</b>
	Outdoor temperature sensor <b>X2658</b>
<b>ComfortSense® 3000 5-2 Day Programmable</b>	
CS3000 5-2 Day Thermostat	<b>11Y05</b>
Sensor/	Remote non-adjustable wall mount 10k averaging <b>47W37</b>
Accessories	Thermostat wall mounting plate <b>X2659</b>
BACnet	<sup>2</sup> 7-Day BACnet Thermostat <b>Y8241</b>
Controls	<sup>3</sup> BACnet Module (factory or field) <b>16X71</b>
<sup>4</sup> BACnet	With Display <b>97W23</b>
Room Sensors	Without Display <b>97W24</b>
<b>Universal Thermostat Guard with Lock (clear)</b>	
	Inside Dimensions (H x W) 5 7/8 x 8 3/8 in. <b>39P21</b>

<sup>1</sup> Remote wall-mount sensors can be applied in any of the following combinations:  
 One Sensor - (1) 47W36, Two Sensors - (2) 47W37, Three Sensors - (2) 47W36 and (1) 47W37  
 Four Sensors - (4) 47W36, Five Sensors - (3) 47W36 and (2) 47W37

<sup>2</sup> BACnet Thermostat (Y8241) will control units with and without the Humiditrol® option. If there is a mix of units equipped with and without Humiditrol on the same site, this thermostat can be used for all units if suitable.

<sup>3</sup> Not compatible with units equipped with Humiditrol® option.

<sup>4</sup> Only compatible with BACnet Module (16X70).

## OPTIONS / ACCESSORIES

Item Description	Catalog Number	Unit Model No			
		092	102	120	
<b>COOLING SYSTEM</b>					
Condensate Drain Trap	PVC	<b>22H54</b>	X	X	X
	Copper	<b>76W27</b>	X	X	X
Corrosion Protection	Factory		O	O	O
Drain Pan Overflow Switch		<b>99W59</b>	X	X	X
Low Ambient Kit		<b>10Z34</b>	X	X	X
Refrigerant Type		R-410A	O	O	O
<b>BLOWER - SUPPLY AIR</b>					
Blower Option	CAV (Constant Air Volume)	Factory	O	O	O
	MSAV (Multi-Stage Air Volume)	Factory	O	O	O
Blower Motors	Belt Drive - 2 hp	Factory	O	O	O
	Belt Drive - 3 hp	Factory	O	O	O
	Belt Drive - 5 hp	Factory	O	O	O
Drive Kits See Blower Data Tables for selection	Kit #1 590-890 rpm	Factory	O	O	O
	Kit #2 800-1105 rpm	Factory	O	O	O
	Kit #3 795-1195 rpm	Factory	O	O	O
	Kit #4 730-970 rpm	Factory	O	O	O
	Kit #5 940-1200 rpm	Factory	O	O	O
	Kit #6 1015-1300 rpm	Factory	O	O	O
	Kit #10 900-1135 rpm	Factory	O	O	O
	Kit #11 1040-1315 rpm	Factory	O	O	O
	Kit #12 1125-1425 rpm	Factory	O	O	O
<b>CABINET</b>					
Combination Coil/Hail Guards		<b>12X21</b>	X	X	X
<b>CONTROLS</b>					
<b>NOTE - Also see Conventional Thermostat Control Systems on page 9 for Additional Options.</b>					
	L Connection® Building Automation System	- - -	X	X	X

NOTE - Catalog numbers shown are for ordering field installed accessories.

OX - Configure To Order (Factory Installed) or Field Installed

O = Configure To Order (Factory Installed)

X = Field Installed

## OPTIONS / ACCESSORIES

Item Description	Catalog Number	Unit Model No			
		092	102	120	
<b>INDOOR AIR QUALITY</b>					
<b>Air Filters</b>					
Healthy Climate® High Efficiency Air Filters 20 x 24 x 2 in. (Order 4 per unit)	MERV 8	<b>14C35</b>	X	X	X
	MERV 13	<b>14C36</b>	X	X	X
Replacement Media Filter With Metal Mesh Frame (includes non-pleated filter media)		<b>Y3063</b>	X	X	X
<b>Indoor Air Quality (CO<sub>2</sub>) Sensors</b>					
Sensor - Wall-mount, off-white plastic cover with LCD display		<b>77N39</b>	X	X	X
Sensor - Wall-mount, off-white plastic cover, no display		<b>87N53</b>	X	X	X
Sensor - Black plastic case with LCD display, rated for plenum mounting		<b>87N52</b>	X	X	X
Sensor - Wall-mount, black plastic case, no display, rated for plenum mounting		<b>87N54</b>	X	X	X
CO <sub>2</sub> Sensor Duct Mounting Kit - for downflow applications		<b>85L43</b>	X	X	X
Aspiration Box - For duct mounting non-plenum rated CO <sub>2</sub> sensors ( <b>87N53</b> or <b>77N39</b> )		<b>90N43</b>	X	X	X
<b>ELECTRICAL</b>					
Voltage 60 hz	208/230V - 3 phase	Factory	O	O	O
	460V - 3 phase	Factory	O	O	O
	575V - 3 phase	Factory	O	O	O
Bottom Power Entry Kit	Z1PEKT01B-1	<b>11H66</b>	X	X	X
<b>ELECTRIC HEAT</b>					
7.5 kW	208/230V-3ph	<b>10Y97</b>	X	X	
	460V-3ph	<b>10Y98</b>	X	X	
	575V-3ph	<b>10Y99</b>	X	X	
15 kW	208/230V-3ph	<b>10Z01</b>	X	X	X
	460V-3ph	<b>10Z03</b>	X	X	X
	575V-3ph	<b>10Z04</b>	X	X	X
22.5 kW	208/230V-3ph	<b>10Z05</b>	X	X	X
	460V-3ph	<b>10Z06</b>	X	X	X
	575V-3ph	<b>10Z07</b>	X	X	X
30 kW	208/230V-3ph	<b>10Z08</b>	X	X	X
	460V-3ph	<b>10Z09</b>	X	X	X
	575V-3ph	<b>10Z10</b>	X	X	X
45 kW	208/230V-3ph	<b>10Z11</b>	X	X	X
	460V-3ph	<b>10Z12</b>	X	X	X
	575V-3ph	<b>10Z13</b>	X	X	X
60 kW	208/230V-3ph	<b>10Z14</b>			X
	460V-3ph	<b>10Z15</b>			X
	575V-3ph	<b>10Z16</b>			X
<b>ELECTRIC HEAT ACCESSORIES</b>					
Unit Fuse Block (required) - See Electrical/Electric Heat Tables for Selection			X	X	X

NOTE - Catalog numbers shown are for ordering field installed accessories.

OX - Configure To Order (Factory Installed) or Field Installed

O = Configure To Order (Factory Installed)

X = Field Installed

## OPTIONS / ACCESSORIES

Item Description	Catalog Number	Unit Model No			
		092	102	120	
<b>ECONOMIZER</b>					
<b>Standard Economizer (Not for Title 24)</b>					
Standard Downflow Economizer with Single Temperature Control - With Barometric Relief Dampers and Air Hoods	10Z29	OX	OX	OX	
Standard Horizontal Economizer with Single Temperature Control - With Barometric Relief Dampers and Air Hoods	11G98	X	X	X	
<b>Standard Economizer Controls (Not for Title 24)</b>					
Single Enthalpy Control	21Z09	X	X	X	
Differential Enthalpy Control (order 2)	21Z09	X	X	X	
<b>High Performance Economizer (Approved for California Title 24 Building Standards / AMCA Class 1A Certified)</b>					
High Performance Downflow Economizer with Single Temperature Control - With Barometric Relief Dampers and Air Hoods	20V25	OX	OX	OX	
High Performance Horizontal Economizer with Single Temperature Control - With Barometric Relief Dampers and Air Hoods	20V26	X	X	X	
<b>High Performance Economizer Controls (Not for Title 24)</b>					
Single Enthalpy Control	11G21	X	X	X	
Differential Enthalpy Control (order 2)	11G21	X	X	X	
<b>Horizontal Low Profile Barometric Relief Dampers With Exhaust Hood</b>					
Horizontal Low Profile Barometric Relief Dampers With Exhaust Hood	53K04	X	X	X	
<b>OUTDOOR AIR</b>					
<b>Outdoor Air Dampers</b>					
Motorized Dampers with outdoor air hood	14G36	X	X	X	
Manual Dampers with outdoor air hood	14G37	X	X	X	
<b>POWER EXHAUST</b>					
Standard Static (Downflow)	208/230V-3ph	10Z70	X	X	X
	460V-3ph	10Z71	X	X	X
Standard Static (Horizontal)	208/230V-3ph	24E01	X	X	X
	460V-3ph	28E01	X	X	X
575V Transformer Kit		59E02	X	X	X
NOTE - Order 575V Transformer Kit with 208/230V Power Exhaust Fan for 575V applications. Order two kits for downflow models, order one kit for horizontal models.					
<b>ROOF CURBS</b>					
<b>Hybrid Roof Curbs, Downflow</b>					
8 in. height		10Z25	X	X	X
14 in. height		10Z26	X	X	X
18 in. height		10Z27	X	X	X
24 in. height		10Z28	X	X	X
<b>CEILING DIFFUSERS</b>					
Step-Down - Order one	RTD11-95S	13K61	X		
	RTD11-135S	13K62		X	X
Flush - Order one	FD11-95S	13K56	X		
	FD11-135S	13K57		X	X
NOTE - Ceiling Diffuser Transitions are not furnished and must be field fabricated.					
NOTE - Catalog numbers shown are for ordering field installed accessories.					
OX - Configure To Order (Factory Installed) or Field Installed					
O = Configure To Order (Factory Installed)					
X = Field Installed					

**SPECIFICATIONS**

**7.5 - 8.5 TON**

General Data		Nominal Tonnage	7.5 Ton	7.5 Ton	8.5 Ton	8.5 Ton
		Model Number	ZHA092S4B	ZHA092S4M	ZHA102S4B	ZHA102S4M
		Efficiency Type	Standard	Standard	Standard	Standard
		Blower Type	CAV Constant Air Volume)	MSAV (Multi-Stage Air Volume)	CAV Constant Air Volume)	MSAV (Multi-Stage Air Volume)
<b>Cooling Performance</b>	Gross Cooling Capacity - Btuh		89,400	89,400	103,200	103,200
	<sup>1</sup> Net Cooling Capacity - Btuh		87,000	87,000	100,000	100,000
	AHRI Rated Air Flow - cfm		2800	2800	3150	3150
	Total Unit Power - kW		7.9	7.9	9.1	9.1
	<sup>1</sup> EER (Btuh/Watt)		11.0	11.0	11.0	11.0
	<sup>1</sup> IEER (Btuh/Watt)		12.2	12.5	12.2	12.5
<b>AHRI Reference No.</b>			202088983	202088984	202088985	202088986
<b>Refrigerant Charge Furnished</b>	Refrigerant Type		R-410A	R-410A	R-410A	R-410A
	Circuit 1		11 lbs. 12 oz.	11 lbs. 12 oz.	11 lbs. 10 oz.	11 lbs. 10 oz.
	Circuit 2		10 lbs. 8 oz.	10 lbs. 8 oz.	9 lbs. 14 oz.	9 lbs. 14 oz.
<b>Heating Performance</b>	<sup>1</sup> Total High Heat Capacity - Btuh		89,000	89,000	100,000	100,000
	Total Unit Power - kW		7.9	7.9	8.9	8.9
	<sup>1</sup> C.O.P.		3.3	3.3	3.3	3.3
	<sup>1</sup> Total Low Heat Capacity - Btuh		53,000	53,000	55,000	55000
	Total Unit Power (kW)		6.9	6.9	7.2	7.2
	<sup>1</sup> C.O.P.		2.25	2.25	2.25	2.25
<b>Electric Heat Available - See page 11</b>			7.5, 15, 22.5, 30 & 45 kW			
<b>Compressor Type (number)</b>			Scroll (2)	Scroll (2)	Scroll (2)	Scroll (2)
<b>Outdoor Coils</b>	Net face area (total) - sq. ft.		26.2	26.2	26.2	26.2
	Tube diameter - in.		3/8	3/8	3/8	3/8
	Number of rows		2	2	2	2
	Fins per inch		20	20	20	20
	Expansion device type		Balance port TXV, removable head			
<b>Outdoor Coil Fans</b>	Motor - (No.) hp		(2) 1/3	(2) 1/3	(2) 1/3	(2) 1/3
	Motor rpm		1075	1075	1075	1075
	Total Motor watts		650	650	650	650
	Diameter - (No.) in.		(2) 24	(2) 24	(2) 24	(2) 24
	Number of blades		3	3	3	3
	Total Air volume - cfm		8800	8800	8800	8800
<b>Indoor Coils</b>	Net face area (total) - sq. ft.		12.8	12.8	12.8	12.8
	Tube diameter - in.		3/8	3/8	3/8	3/8
	Number of rows		3	3	4	4
	Fins per inch		14	14	14	14
	Drain connection - Number and size		(1) 1 in. NPT coupling			
	Expansion device type		Refrigerant Metering Orifice (RFC)			
<b><sup>2</sup> Indoor Blower and Drive Selection</b>	Nominal motor output		2 hp, 3 hp, 5 hp			
	Maximum usable motor output (US Only)		2.3 hp, 3.45 hp, 5.75 hp			
	Motor - Drive kit number		2 hp <b>Kit 1</b> 590-890 rpm <b>Kit 2</b> 800-1105 rpm <b>Kit 3</b> 795-1195 rpm 3 hp <b>Kit 4</b> 730-970 rpm <b>Kit 5</b> 940-1200 rpm <b>Kit 6</b> 1015-1300 rpm 5 hp <b>Kit 10</b> 900-1135 rpm <b>Kit 11</b> 1040-1315 rpm <b>Kit 12</b> 1125-1425 rpm			
Blower wheel nominal diameter x width - in.			(1) 15 X 15	(1) 15 X 15	(1) 15 X 15	(1) 15 X 15
<b>Filters</b>	Type of filter		Disposable			
	Number and size - in.		(4) 20 x 24 x 2			
<b>Electrical characteristics</b>			208/230V, 460V or 575V - 60 hertz - 3 phase			

NOTE - Net capacity includes evaporator blower motor heat deduction. Gross capacity does not include evaporator blower motor heat deduction.

<sup>1</sup> AHRI Certified to AHRI Standard 340/360:

**Cooling Ratings** - 95°F outdoor air temperature and 80°F db/67°F wb entering indoor coil air.

**High Temperature Heating Ratings** - 47°F db/43°F wb outdoor air temperature and 70°F entering indoor coil air.

**Low Temperature Heating Ratings** - 17°F db/15°F wb outdoor air temperature and 70°F entering indoor coil air.

<sup>2</sup> Using total air volume and system static pressure requirements determine from blower performance tables rpm and motor output required. Maximum usable output of motors furnished are shown. In Canada, nominal motor output is also maximum usable motor output. If motors of comparable output are used, be sure to keep within the service factor limitations outlined on the motor nameplate.

NOTE - Units equipped with MSAV® (Multi-Stage Air Volume) option are limited to a motor service factor of 1.0.

**SPECIFICATIONS**

**10 TON**

General Data		Nominal Tonnage	10 Ton	10 Ton
		<b>Model Number</b>	<b>ZHA120S4B</b>	<b>ZHA120S4M</b>
		<b>Efficiency Type</b>	<b>Standard</b>	<b>Standard</b>
		<b>Blower Type</b>	CAV Constant Air Volume)	MSAV (Multi-Stage Air Volume)
<b>Cooling Performance</b>	Gross Cooling Capacity - Btuh		121,900	121,900
	<sup>1</sup> Net Cooling Capacity - Btuh		118,000	118,000
	AHRI Rated Air Flow - cfm		3600	3600
	Total Unit Power - kW		10.7	10.7
	<sup>1</sup> EER (Btuh/Watt)		11.0	11.0
	<sup>1</sup> IEER (Btuh/Watt)		11.3	12.5
<b>AHRI Reference No.</b>			7500055	202088987
<b>Refrigerant Charge Furnished</b>		<b>Refrigerant Type</b>	R-410A	R-410A
		Circuit 1	16 lbs. 0 oz.	16 lbs. 0 oz.
		Circuit 2	14 lbs. 12 oz.	14 lbs. 12 oz.
<b>Heating Performance</b>	<sup>1</sup> Total High Heat Capacity - Btuh		116,000	116,000
	Total Unit Power - kW		10.3	10.3
	<sup>1</sup> C.O.P.		3.3	3.3
	<sup>1</sup> Total Low Heat Capacity - Btuh		70,000	70,000
	Total Unit Power (kW)		9.1	9.1
		<sup>1</sup> C.O.P.	2.25	2.25
<b>Electric Heat Available - See page 11</b>			15, 22.5, 30, 45 and 60 KW	
<b>Compressor Type (number)</b>			Scroll (2)	Scroll (2)
<b>Outdoor Coils</b>	Net face area (total) - sq. ft.		26.2	26.2
	Tube diameter - in.		3/8	3/8
	Number of rows		3	3
	Fins per inch		20	20
	Expansion device type		Balance port TXV, removable head	
<b>Outdoor Coil Fans</b>	Motor - (No.) hp		(2) 1/2	(2) 1/2
	Motor rpm		1075	1075
	Total Motor watts		960	960
	Diameter - (No.) in.		(2) 24	(2) 24
	Number of blades		3	3
	Total Air volume - cfm		9000	9000
<b>Indoor Coils</b>	Net face area (total) - sq. ft.		13.54	13.54
	Tube diameter - in.		3/8	3/8
	Number of rows		4	4
	Fins per inch		14	14
	Drain connection - Number and size		(1) 1 in. NPT coupling	
		Expansion device type	Refrigerant Metering Orifice (RFC)	
<b><sup>2</sup> Indoor Blower and Drive Selection</b>	Nominal motor output		2 hp, 3 hp, 5 hp	
	Maximum usable motor output (US Only)		2.3 hp, 3.45 hp, 5.75 hp	
	Motor - Drive kit number		2 hp <b>Kit 1</b> 590-890 rpm <b>Kit 2</b> 800-1105 rpm <b>Kit 3</b> 795-1195 rpm 3 hp <b>Kit 4</b> 730-970 rpm <b>Kit 5</b> 940-1200 rpm <b>Kit 6</b> 1015-1300 rpm 5 hp <b>Kit 10</b> 900-1135 rpm <b>Kit 11</b> 1040-1315 rpm <b>Kit 12</b> 1125-1425 rpm	
	Blower wheel nominal diameter x width - in.		(1) 15 X 15	(1) 15 X 15
<b>Filters</b>	Type of filter		Disposable	
	Number and size - in.		(4) 20 x 24 x 2	
<b>Electrical characteristics</b>			208/230V, 460V or 575V - 60 hertz - 3 phase	

NOTE - Net capacity includes evaporator blower motor heat deduction. Gross capacity does not include evaporator blower motor heat deduction.

<sup>1</sup> AHRI Certified to AHRI Standard 340/360:

**Cooling Ratings** - 95°F outdoor air temperature and 80°F db/67°F wb entering indoor coil air.

**High Temperature Heating Ratings** - 47°F db/43°F wb outdoor air temperature and 70°F entering indoor coil air.

**Low Temperature Heating Ratings** - 17°F db/15°F wb outdoor air temperature and 70°F entering indoor coil air.

<sup>2</sup> Using total air volume and system static pressure requirements determine from blower performance tables rpm and motor output required. Maximum usable output of motors furnished are shown. In Canada, nominal motor output is also maximum usable motor output. If motors of comparable output are used, be sure to keep within the service factor limitations outlined on the motor nameplate.

NOTE - Units equipped with MSAV® (Multi-Stage Air Volume) option are limited to a motor service factor of 1.0.

## RATINGS

NOTE – For Temperatures and Capacities not shown in tables, see bulletin – Cooling Unit Rating Table Correction Factor Data in Miscellaneous Engineering Data section.

### 7.5 TON COOLING STANDARD EFFICIENCY ZHA092S4 (1ST STAGE) - CONSTANT AIR VOLUME

Entering Wet Bulb Temperature	Total Air Volume	Outdoor Air Temperature Entering Outdoor Coil																			
		65°F					75°F					85°F					95°F				
		Total Cool Cap.	Comp. Motor Input	Sensible To Total Ratio (S/T) Dry Bulb			Total Cool Cap.	Comp. Motor Input	Sensible To Total Ratio (S/T) Dry Bulb			Total Cool Cap.	Comp. Motor Input	Sensible To Total Ratio (S/T) Dry Bulb			Total Cool Cap.	Comp. Motor Input	Sensible To Total Ratio (S/T) Dry Bulb		
				75°F	80°F	85°F			75°F	80°F	85°F			75°F	80°F	85°F			75°F	80°F	85°F
cfm	kBtuh	kW				kBtuh	kW				kBtuh	kW				kBtuh	kW				
63°F	2400	52.4	2.75	0.57	0.85	1	49.6	3.17	0.58	0.92	1	46.7	3.63	0.59	0.99	1	43.9	4.14	0.61	1	1
	3000	54.9	2.76	0.61	1	1	52.4	3.18	0.63	1	1	49.5	3.64	0.64	1	1	46.6	4.15	0.74	1	1
	3600	57.5	2.76	0.71	1	1	54.7	3.19	0.79	1	1	51.8	3.65	0.87	1	1	48.7	4.16	0.96	1	1
67°F	2400	55.6	2.76	0.44	0.55	0.73	52.6	3.18	0.44	0.56	0.8	49.6	3.64	0.45	0.57	0.89	46.3	4.15	0.45	0.59	0.97
	3000	57.9	2.76	0.47	0.6	0.99	54.7	3.19	0.47	0.61	1	51.4	3.65	0.48	0.63	1	48.1	4.16	0.49	0.64	1
	3600	59.5	2.76	0.5	0.64	1	56.2	3.19	0.5	0.71	1	52.8	3.65	0.51	0.8	1	49.4	4.16	0.53	0.89	1
71°F	2400	59	2.76	0.32	0.43	0.54	56	3.19	0.32	0.44	0.55	52.7	3.65	0.32	0.44	0.56	49.3	4.16	0.32	0.45	0.57
	3000	61.3	2.76	0.34	0.46	0.58	58.1	3.19	0.34	0.47	0.6	54.7	3.65	0.34	0.48	0.61	51.2	4.17	0.34	0.49	0.63
	3600	63.1	2.76	0.35	0.49	0.63	59.6	3.19	0.35	0.5	0.64	56.2	3.66	0.35	0.51	0.72	52.6	4.17	0.35	0.52	0.81

### 7.5 TON COOLING STANDARD EFFICIENCY ZHA092S4 (2ND STAGE) - CONSTANT AIR VOLUME

Entering Wet Bulb Temperature	Total Air Volume	Outdoor Air Temperature Entering Outdoor Coil																			
		85°F					95°F					105°F					115°F				
		Total Cool Cap.	Comp. Motor Input	Sensible To Total Ratio (S/T) Dry Bulb			Total Cool Cap.	Comp. Motor Input	Sensible To Total Ratio (S/T) Dry Bulb			Total Cool Cap.	Comp. Motor Input	Sensible To Total Ratio (S/T) Dry Bulb			Total Cool Cap.	Comp. Motor Input	Sensible To Total Ratio (S/T) Dry Bulb		
				75°F	80°F	85°F			75°F	80°F	85°F			75°F	80°F	85°F			75°F	80°F	85°F
cfm	kBtuh	kW				kBtuh	kW				kBtuh	kW				kBtuh	kW				
63°F	2400	84.6	5.72	0.71	0.85	0.95	79	6.54	0.72	0.87	0.96	73.1	7.45	0.73	0.89	0.98	66.7	8.45	0.75	0.91	0.99
	3000	89.8	5.74	0.76	0.91	0.99	84.2	6.57	0.78	0.93	1	78.1	7.48	0.8	0.94	1	71.6	8.49	0.83	0.96	1
	3600	94.4	5.76	0.82	0.95	1	88.4	6.59	0.84	0.96	1	82.1	7.51	0.86	0.98	1	75.4	8.51	0.89	1	1
67°F	2400	90.4	5.74	0.56	0.69	0.82	84.6	6.56	0.56	0.7	0.84	78.4	7.49	0.56	0.71	0.86	71.7	8.49	0.56	0.73	0.89
	3000	95.6	5.77	0.59	0.74	0.89	89.4	6.59	0.59	0.76	0.91	82.9	7.52	0.6	0.77	0.92	75.6	8.52	0.61	0.8	0.94
	3600	99.4	5.79	0.62	0.79	0.93	93	6.61	0.63	0.81	0.94	86.1	7.53	0.64	0.84	0.96	78.6	8.54	0.65	0.87	0.98
71°F	2400	96	5.77	0.42	0.54	0.66	90.2	6.6	0.41	0.54	0.67	84	7.52	0.4	0.55	0.69	77	8.53	0.4	0.55	0.7
	3000	101.7	5.79	0.43	0.58	0.72	95.5	6.62	0.43	0.58	0.73	88.7	7.54	0.42	0.59	0.75	81.2	8.54	0.42	0.6	0.78
	3600	105.7	5.8	0.45	0.61	0.77	99.2	6.63	0.44	0.62	0.79	92.2	7.55	0.44	0.63	0.81	84.4	8.56	0.44	0.64	0.84

### 7.5 TON HEATING STANDARD EFFICIENCY ZHA092S4 - CONSTANT AIR VOLUME

Indoor Coil Air Volume 70°F Dry Bulb cfm	Air Temperature Entering Outdoor Coil									
	65°F		45°F		25°F		5°F		-15°F	
	Total Heating Capacity	Comp. Motor Input	Total Heating Capacity	Comp. Motor Input	Total Heating Capacity	Comp. Motor Input	Total Heating Capacity	Comp. Motor Input	Total Heating Capacity	Comp. Motor Input
	kBtuh	kW	kBtuh	kW	kBtuh	kW	kBtuh	kW	kBtuh	kW
2400	119.7	7.82	90.9	7.27	61.7	6.72	37.4	5.98	18.9	4.51
3000	121.6	7.26	92.8	6.71	63.6	6.16	39.3	5.41	20.8	3.95
3600	123	6.92	94.2	6.37	65	5.82	40.7	5.08	22.2	3.61

## RATINGS

NOTE - For Temperatures and Capacities not shown in tables, see bulletin - Cooling Unit Rating Table Correction Factor Data in Miscellaneous Engineering Data section.

### 8.5 TON COOLING STANDARD EFFICIENCY ZHA102S4 (1ST STAGE) - CONSTANT AIR VOLUME

Entering Wet Bulb Temperature	Total Air Volume	Outdoor Air Temperature Entering Outdoor Coil																			
		65°F					75°F					85°F					95°F				
		Total Cool Cap.	Comp. Motor Input	Sensible To Total Ratio (S/T) Dry Bulb			Total Cool Cap.	Comp. Motor Input	Sensible To Total Ratio (S/T) Dry Bulb			Total Cool Cap.	Comp. Motor Input	Sensible To Total Ratio (S/T) Dry Bulb			Total Cool Cap.	Comp. Motor Input	Sensible To Total Ratio (S/T) Dry Bulb		
				75°F	80°F	85°F			75°F	80°F	85°F			75°F	80°F	85°F			75°F	80°F	85°F
cfm	kBtuh	kW				kBtuh	kW				kBtuh	kW				kBtuh	kW				
63°F	2720	59.4	2.7	0.63	1	1	56.5	3.12	0.65	1	1	53.5	3.57	0.66	1	1	50.3	4.07	0.68	1	1
	3400	63.2	2.7	0.69	1	1	60	3.12	0.71	1	1	56.8	3.58	0.72	1	1	53.5	4.08	0.92	1	1
	4080	66	2.7	0.83	1	1	62.8	3.12	0.99	1	1	59.4	3.58	1	1	1	55.8	4.08	1	1	1
67°F	2720	62.7	2.7	0.48	0.62	0.83	59.4	3.12	0.49	0.63	1	55.7	3.58	0.5	0.65	1	52	4.07	0.5	0.66	1
	3400	65	2.7	0.52	0.67	1	61.4	3.12	0.53	0.69	1	57.8	3.58	0.54	0.71	1	53.9	4.08	0.55	0.73	1
	4080	66.9	2.7	0.56	0.72	1	63.2	3.12	0.57	0.87	1	59.4	3.58	0.58	1	1	55.8	4.08	0.6	1	1
71°F	2720	66.9	2.7	0.35	0.48	0.6	63.5	3.12	0.35	0.48	0.61	59.8	3.58	0.35	0.49	0.63	55.9	4.08	0.35	0.5	0.65
	3400	69.2	2.69	0.37	0.52	0.66	65.7	3.11	0.37	0.53	0.67	61.7	3.58	0.37	0.54	0.69	57.7	4.08	0.37	0.55	0.71
	4080	71.1	2.69	0.38	0.55	0.71	67.1	3.11	0.39	0.56	0.72	63.1	3.57	0.39	0.58	0.91	58.9	4.08	0.39	0.6	1

### 8.5 TON COOLING STANDARD EFFICIENCY ZHA102S4 (2ND STAGE) - CONSTANT AIR VOLUME

Entering Wet Bulb Temperature	Total Air Volume	Outdoor Air Temperature Entering Outdoor Coil																			
		85°F					95°F					105°F					115°F				
		Total Cool Cap.	Comp. Motor Input	Sensible To Total Ratio (S/T) Dry Bulb			Total Cool Cap.	Comp. Motor Input	Sensible To Total Ratio (S/T) Dry Bulb			Total Cool Cap.	Comp. Motor Input	Sensible To Total Ratio (S/T) Dry Bulb			Total Cool Cap.	Comp. Motor Input	Sensible To Total Ratio (S/T) Dry Bulb		
				75°F	80°F	85°F			75°F	80°F	85°F			75°F	80°F	85°F			75°F	80°F	85°F
cfm	kBtuh	kW				kBtuh	kW				kBtuh	kW				kBtuh	kW				
63°F	2720	99.6	6.85	0.68	0.83	0.97	92	7.8	0.68	0.86	0.99	83.9	8.85	0.69	0.89	1	75.3	10.04	0.71	0.93	1
	3400	106	6.89	0.73	0.92	1	97.9	7.83	0.75	0.95	1	89.8	8.9	0.77	0.97	1	81.3	10.1	0.81	0.99	1
	4080	111.4	6.91	0.8	0.98	1	103.5	7.87	0.82	0.99	1	95.2	8.94	0.86	1	1	86.7	10.13	0.9	1	1
67°F	2720	107.6	6.89	0.52	0.66	0.79	99.5	7.84	0.52	0.66	0.82	91.4	8.91	0.52	0.67	0.84	82.2	10.1	0.52	0.69	0.88
	3400	113.7	6.92	0.56	0.71	0.89	105.2	7.88	0.56	0.73	0.92	96.3	8.94	0.57	0.74	0.94	86.7	10.13	0.57	0.78	0.97
	4080	118.2	6.94	0.6	0.77	0.96	109.4	7.89	0.6	0.8	0.97	100.1	8.97	0.61	0.83	0.99	90	10.15	0.62	0.87	1
71°F	2720	115.5	6.93	0.39	0.51	0.63	107.4	7.89	0.38	0.51	0.64	98.9	8.96	0.37	0.51	0.65	89.3	10.15	0.35	0.51	0.67
	3400	122.1	6.95	0.41	0.55	0.69	113.3	7.91	0.4	0.55	0.7	104	8.98	0.39	0.56	0.72	94.1	10.18	0.38	0.57	0.75
	4080	126.5	6.96	0.42	0.58	0.75	117.6	7.93	0.41	0.59	0.77	108	9.01	0.41	0.6	0.8	97.5	10.2	0.4	0.62	0.85

### 8.5 TON HEATING STANDARD EFFICIENCY ZHA102S4 - CONSTANT AIR VOLUME

Indoor Coil Air Volume 70°F Dry Bulb cfm	Air Temperature Entering Outdoor Coil									
	65°F		45°F		25°F		5°F		-15°F	
	Total Heating Capacity	Comp. Motor Input	Total Heating Capacity	Comp. Motor Input	Total Heating Capacity	Comp. Motor Input	Total Heating Capacity	Comp. Motor Input	Total Heating Capacity	Comp. Motor Input
	kBtuh	kW	kBtuh	kW	kBtuh	kW	kBtuh	kW	kBtuh	kW
2720	127.2	7.97	95.8	7.33	63.7	6.67	38.8	5.97	19.6	4.5
3400	129.4	7.45	98	6.81	65.9	6.15	41	5.44	21.7	3.98
4080	131.1	7.12	99.7	6.48	67.6	5.82	42.7	5.11	23.4	3.65



## RATINGS

NOTE – For Temperatures and Capacities not shown in tables, see bulletin – Cooling Unit Rating Table Correction Factor Data in Miscellaneous Engineering Data section.

### 10 TON COOLING STANDARD EFFICIENCY ZHA120S4 (1ST STAGE) - CONSTANT AIR VOLUME

Entering Wet Bulb Temperature	Total Air Volume	Outdoor Air Temperature Entering Outdoor Coil																							
		65°F						75°F						85°F						95°F					
		Total Cool Cap.	Comp. Motor Input	Sensible To Total Ratio (S/T) Dry Bulb			Total Cool Cap.	Comp. Motor Input	Sensible To Total Ratio (S/T) Dry Bulb			Total Cool Cap.	Comp. Motor Input	Sensible To Total Ratio (S/T) Dry Bulb			Total Cool Cap.	Comp. Motor Input	Sensible To Total Ratio (S/T) Dry Bulb						
				75°F	80°F	85°F			75°F	80°F	85°F			75°F	80°F	85°F			75°F	80°F	85°F				
cfm	kBtuh	kW				kBtuh	kW				kBtuh	kW				kBtuh	kW								
63°F	3200	67.1	2.84	1	0.93	0.94	62.9	3.22	1	0.93	0.93	58.6	3.65	1	0.92	0.93	54	4.12	1	0.92	0.92				
	4000	71	2.88	1	0.92	0.93	66.6	3.26	1	0.91	0.92	61.9	3.68	1	0.91	0.91	57.3	4.16	0.91	0.91	0.91				
	4800	73.9	2.91	0.91	0.91	0.91	69.2	3.29	0.91	0.91	0.91	64.5	3.71	0.91	0.91	0.91	59.6	4.19	0.91	0.91	0.91				
67°F	3200	69.8	2.87	1	1	0.96	65.1	3.24	1	1	0.93	60.1	3.66	1	1	0.93	55.1	4.13	1	1	0.92				
	4000	72.3	2.89	1	1	0.93	67.3	3.27	1	1	0.92	62.3	3.69	1	1	0.91	57.3	4.16	1	0.91	0.91				
	4800	74.1	2.9	1	1	0.91	69.3	3.29	1	0.95	0.91	64.6	3.72	1	0.91	0.91	59.5	4.19	1	0.91	0.91				
71°F	3200	74.3	2.91	1	1	1	69.3	3.29	1	1	1	64.2	3.71	1	1	1	58.9	4.18	1	1	1				
	4000	76.4	2.94	1	1	1	71.4	3.32	1	1	1	66.1	3.73	1	1	1	60.5	4.2	1	1	0.93				
	4800	77.9	2.95	1	1	1	72.7	3.33	1	1	1	67.4	3.75	1	1	0.92	61.7	4.22	1	1	0.91				

### 10 TON COOLING STANDARD EFFICIENCY ZHA120S4 (2ND STAGE) - CONSTANT AIR VOLUME

Entering Wet Bulb Temperature	Total Air Volume	Outdoor Air Temperature Entering Outdoor Coil																							
		85°F						95°F						105°F						115°F					
		Total Cool Cap.	Comp. Motor Input	Sensible To Total Ratio (S/T) Dry Bulb			Total Cool Cap.	Comp. Motor Input	Sensible To Total Ratio (S/T) Dry Bulb			Total Cool Cap.	Comp. Motor Input	Sensible To Total Ratio (S/T) Dry Bulb			Total Cool Cap.	Comp. Motor Input	Sensible To Total Ratio (S/T) Dry Bulb						
				75°F	80°F	85°F			75°F	80°F	85°F			75°F	80°F	85°F			75°F	80°F	85°F				
cfm	kBtuh	kW				kBtuh	kW				kBtuh	kW				kBtuh	kW								
63°F	3200	118	7.62	0.68	0.84	0.99	108.4	8.63	0.69	0.86	1	98.3	9.77	0.7	0.89	1	87.3	11.08	0.72	0.94	1				
	4000	125.3	7.68	0.75	0.93	1	115.3	8.69	0.76	0.96	1	104.8	9.83	0.79	0.99	1	94.1	11.14	0.81	1	1				
	4800	131.2	7.74	0.81	1	1	121.4	8.75	0.83	1	1	111.7	9.9	0.86	1	1	101.1	11.23	0.9	1	1				
67°F	3200	127.3	7.71	0.53	0.66	0.81	117.4	8.71	0.53	0.67	0.83	106.7	9.86	0.52	0.69	0.85	95.4	11.16	0.52	0.7	0.89				
	4000	134.4	7.77	0.57	0.72	0.89	123.9	8.78	0.57	0.74	0.92	112.6	9.91	0.57	0.76	0.96	100.5	11.21	0.57	0.79	1				
	4800	139.7	7.82	0.6	0.79	0.97	128.4	8.82	0.61	0.81	1	116.9	9.96	0.62	0.84	1	104.4	11.25	0.63	0.88	1				
71°F	3200	136.7	7.79	0.39	0.52	0.64	126.4	8.8	0.38	0.52	0.65	115.4	9.94	0.36	0.52	0.66	103.7	11.24	0.34	0.52	0.68				
	4000	143.9	7.86	0.41	0.56	0.7	133.1	8.86	0.4	0.56	0.72	121.5	10.01	0.39	0.57	0.74	109	11.29	0.37	0.58	0.77				
	4800	149.1	7.92	0.43	0.6	0.77	137.8	8.92	0.42	0.6	0.79	125.4	10.05	0.41	0.61	0.82	112.4	11.35	0.4	0.63	0.86				

### 10 TON HEATING STANDARD EFFICIENCY ZH120S4 - CONSTANT AIR VOLUME

Indoor Coil Air Volume 70°F Dry Bulb cfm	Air Temperature Entering Outdoor Coil									
	65°F		45°F		25°F		5°F		-15°F	
	Total Heating Capacity	Comp. Motor Input	Total Heating Capacity	Comp. Motor Input	Total Heating Capacity	Comp. Motor Input	Total Heating Capacity	Comp. Motor Input	Total Heating Capacity	Comp. Motor Input
	kBtuh	kW	kBtuh	kW	kBtuh	kW	kBtuh	kW	kBtuh	kW
3200	145.4	9.22	112.8	8.29	79.6	7.31	51.1	6.44	25.3	4.9
4000	147.9	8.64	115.2	7.7	82.1	6.73	53.6	5.85	27.8	4.31
4800	149.8	8.28	117.1	7.34	84	6.37	55.5	5.49	29.7	3.95

## RATINGS

NOTE - For Temperatures and Capacities not shown in tables, see bulletin - Cooling Unit Rating Table Correction Factor Data in Miscellaneous Engineering Data section.

### 7.5 TON COOLING STANDARD EFFICIENCY ZHA092S4 (1ST STAGE) - MSAV (Multi-Stage Air Volume) SUPPLY AIR BLOWER

Entering Wet Bulb Temperature	Total Air Volume	Outdoor Air Temperature Entering Outdoor Coil																			
		65°F					75°F					85°F					95°F				
		Total Cool Cap.	Comp. Motor Input	Sensible To Total Ratio (S/T) Dry Bulb			Total Cool Cap.	Comp. Motor Input	Sensible To Total Ratio (S/T) Dry Bulb			Total Cool Cap.	Comp. Motor Input	Sensible To Total Ratio (S/T) Dry Bulb			Total Cool Cap.	Comp. Motor Input	Sensible To Total Ratio (S/T) Dry Bulb		
				75°F	80°F	85°F			75°F	80°F	85°F			75°F	80°F	85°F			75°F	80°F	85°F
cfm	kBtuh	kW	75°F	80°F	85°F	kBtuh	kW	75°F	80°F	85°F	kBtuh	kW	75°F	80°F	85°F	kBtuh	kW	75°F	80°F	85°F	
63°F	1680	47.6	2.68	0.57	0.73	0.96	45	3.09	0.58	0.76	0.99	42.3	3.54	0.58	0.8	1	39.5	4.03	0.59	0.83	1
	2100	50	2.69	0.61	0.86	1	47.3	3.11	0.62	0.89	1	44.5	3.56	0.63	0.93	1	41.5	4.05	0.66	0.97	1
	2520	51.9	2.7	0.67	0.96	1	49.2	3.12	0.69	0.99	1	46.4	3.57	0.73	1	1	43.6	4.07	0.77	1	1
67°F	1680	50.5	2.7	0.45	0.55	0.68	48	3.11	0.45	0.56	0.7	45.1	3.56	0.45	0.57	0.73	42.2	4.06	0.46	0.58	0.77
	2100	53.2	2.71	0.48	0.59	0.8	50.4	3.12	0.48	0.6	0.83	47.5	3.58	0.48	0.61	0.87	44.3	4.07	0.49	0.63	0.92
	2520	55.1	2.71	0.5	0.63	0.91	52.2	3.12	0.5	0.66	0.94	49.1	3.59	0.51	0.69	0.97	45.8	4.08	0.52	0.73	1
71°F	1680	53.6	2.71	0.35	0.44	0.53	50.8	3.12	0.34	0.44	0.54	48	3.58	0.34	0.44	0.55	45.1	4.08	0.33	0.45	0.56
	2100	56.4	2.71	0.36	0.47	0.57	53.4	3.13	0.35	0.47	0.58	50.4	3.59	0.35	0.47	0.59	47.2	4.09	0.35	0.48	0.61
	2520	58.4	2.71	0.37	0.49	0.61	55.4	3.13	0.36	0.5	0.62	52.1	3.59	0.36	0.5	0.65	48.8	4.09	0.36	0.51	0.69

### 7.5 TON COOLING STANDARD EFFICIENCY ZHA092S4 (2ND STAGE) - MSAV (Multi-Stage Air Volume) SUPPLY AIR BLOWER

Entering Wet Bulb Temperature	Total Air Volume	Outdoor Air Temperature Entering Outdoor Coil																			
		85°F					95°F					105°F					115°F				
		Total Cool Cap.	Comp. Motor Input	Sensible To Total Ratio (S/T) Dry Bulb			Total Cool Cap.	Comp. Motor Input	Sensible To Total Ratio (S/T) Dry Bulb			Total Cool Cap.	Comp. Motor Input	Sensible To Total Ratio (S/T) Dry Bulb			Total Cool Cap.	Comp. Motor Input	Sensible To Total Ratio (S/T) Dry Bulb		
				75°F	80°F	85°F			75°F	80°F	85°F			75°F	80°F	85°F			75°F	80°F	85°F
cfm	kBtuh	kW	75°F	80°F	85°F	kBtuh	kW	75°F	80°F	85°F	kBtuh	kW	75°F	80°F	85°F	kBtuh	kW	75°F	80°F	85°F	
63°F	2400	84.6	5.72	0.71	0.85	0.95	79	6.54	0.72	0.87	0.96	73.1	7.45	0.73	0.89	0.98	66.7	8.45	0.75	0.91	0.99
	3000	89.8	5.74	0.76	0.91	0.99	84.2	6.57	0.78	0.93	1	78.1	7.48	0.8	0.94	1	71.6	8.49	0.83	0.96	1
	3600	94.4	5.76	0.82	0.95	1	88.4	6.59	0.84	0.96	1	82.1	7.51	0.86	0.98	1	75.4	8.51	0.89	1	1
67°F	2400	90.4	5.74	0.56	0.69	0.82	84.6	6.56	0.56	0.7	0.84	78.4	7.49	0.56	0.71	0.86	71.7	8.49	0.56	0.73	0.89
	3000	95.6	5.77	0.59	0.74	0.89	89.4	6.59	0.59	0.76	0.91	82.9	7.52	0.6	0.77	0.92	75.6	8.52	0.61	0.8	0.94
	3600	99.4	5.79	0.62	0.79	0.93	93	6.61	0.63	0.81	0.94	86.1	7.53	0.64	0.84	0.96	78.6	8.54	0.65	0.87	0.98
71°F	2400	96	5.77	0.42	0.54	0.66	90.2	6.6	0.41	0.54	0.67	84	7.52	0.4	0.55	0.69	77	8.53	0.4	0.55	0.7
	3000	101.7	5.79	0.43	0.58	0.72	95.5	6.62	0.43	0.58	0.73	88.7	7.54	0.42	0.59	0.75	81.2	8.54	0.42	0.6	0.78
	3600	105.7	5.8	0.45	0.61	0.77	99.2	6.63	0.44	0.62	0.79	92.2	7.55	0.44	0.63	0.81	84.4	8.56	0.44	0.64	0.84

### 7.5 TON HEATING STANDARD EFFICIENCY ZHA092S4 - MSAV (Multi-Stage Air Volume) SUPPLY AIR BLOWER

Indoor Coil Air Volume 70°F Dry Bulb cfm	Air Temperature Entering Outdoor Coil									
	65°F		45°F		25°F		5°F		-15°F	
	Total Heating Capacity	Comp. Motor Input	Total Heating Capacity	Comp. Motor Input	Total Heating Capacity	Comp. Motor Input	Total Heating Capacity	Comp. Motor Input	Total Heating Capacity	Comp. Motor Input
2400	119.7	7.82	90.9	7.27	61.7	6.72	37.4	5.98	18.9	4.51
3000	121.6	7.26	92.8	6.71	63.6	6.16	39.3	5.41	20.8	3.95
3600	123	6.92	94.2	6.37	65	5.82	40.7	5.08	22.2	3.61

## RATINGS

NOTE – For Temperatures and Capacities not shown in tables, see bulletin – Cooling Unit Rating Table Correction Factor Data in Miscellaneous Engineering Data section.

### 8.5 TON COOLING STANDARD EFFICIENCY ZHA102S4 (1ST STAGE) - MSAV (Multi-Stage Air Volume) SUPPLY AIR BLOWER

Entering Wet Bulb Temperature	Total Air Volume	Outdoor Air Temperature Entering Outdoor Coil																							
		65°F						75°F						85°F						95°F					
		Total Cool Cap.	Comp. Motor Input	Sensible To Total Ratio (S/T)			Total Cool Cap.	Comp. Motor Input	Sensible To Total Ratio (S/T)			Total Cool Cap.	Comp. Motor Input	Sensible To Total Ratio (S/T)			Total Cool Cap.	Comp. Motor Input	Sensible To Total Ratio (S/T)						
				Dry Bulb					Dry Bulb					Dry Bulb					Dry Bulb						
cfm	kBtuh	kW	75°F	80°F	85°F	kBtuh	kW	75°F	80°F	85°F	kBtuh	kW	75°F	80°F	85°F	kBtuh	kW	75°F	80°F	85°F					
63°F	1920	56.1	2.69	0.6	0.79	1	53.1	3.1	0.61	0.83	1	49.9	3.55	0.62	0.87	1	46.6	4.04	0.64	0.93	1				
	2400	59	2.69	0.65	0.95	1	55.9	3.11	0.67	0.99	1	52.7	3.57	0.69	1	1	49.7	4.06	0.73	1	1				
	2880	61.7	2.7	0.73	1	1	58.8	3.12	0.77	1	1	55.7	3.57	0.81	1	1	52.4	4.07	0.87	1	1				
67°F	1920	60	2.7	0.47	0.59	0.72	56.9	3.11	0.47	0.59	0.75	53.5	3.57	0.48	0.61	0.8	49.9	4.06	0.48	0.62	0.85				
	2400	62.7	2.7	0.5	0.63	0.88	59.4	3.12	0.51	0.65	0.93	55.9	3.58	0.51	0.66	0.97	52.1	4.07	0.52	0.68	1				
	2880	64.8	2.7	0.53	0.69	1	61.3	3.12	0.54	0.72	1	57.6	3.58	0.55	0.77	1	53.8	4.08	0.56	0.82	1				
71°F	1920	64	2.7	0.35	0.46	0.57	60.7	3.12	0.35	0.47	0.58	57.3	3.58	0.35	0.47	0.59	53.6	4.07	0.34	0.47	0.6				
	2400	67	2.7	0.37	0.49	0.62	63.5	3.12	0.37	0.5	0.62	59.9	3.58	0.37	0.51	0.64	56	4.08	0.36	0.51	0.66				
	2880	69.2	2.7	0.38	0.53	0.66	65.5	3.12	0.38	0.53	0.68	61.6	3.58	0.38	0.54	0.72	57.7	4.08	0.38	0.55	0.77				

### 8.5 TON COOLING STANDARD EFFICIENCY ZHA102S4 (2ND STAGE) - MSAV (Multi-Stage Air Volume) SUPPLY AIR BLOWER

Entering Wet Bulb Temperature	Total Air Volume	Outdoor Air Temperature Entering Outdoor Coil																							
		85°F						95°F						105°F						115°F					
		Total Cool Cap.	Comp. Motor Input	Sensible To Total Ratio (S/T)			Total Cool Cap.	Comp. Motor Input	Sensible To Total Ratio (S/T)			Total Cool Cap.	Comp. Motor Input	Sensible To Total Ratio (S/T)			Total Cool Cap.	Comp. Motor Input	Sensible To Total Ratio (S/T)						
				Dry Bulb					Dry Bulb					Dry Bulb					Dry Bulb						
cfm	kBtuh	kW	75°F	80°F	85°F	kBtuh	kW	75°F	80°F	85°F	kBtuh	kW	75°F	80°F	85°F	kBtuh	kW	75°F	80°F	85°F					
63°F	2720	99.6	6.85	0.68	0.83	0.97	92	7.8	0.68	0.86	0.99	83.9	8.85	0.69	0.89	1	75.3	10.04	0.71	0.93	1				
	3400	106	6.89	0.73	0.92	1	97.9	7.83	0.75	0.95	1	89.8	8.9	0.77	0.97	1	81.3	10.1	0.81	0.99	1				
	4080	111.4	6.91	0.8	0.98	1	103.5	7.87	0.82	0.99	1	95.2	8.94	0.86	1	1	86.7	10.13	0.9	1	1				
67°F	2720	107.6	6.89	0.52	0.66	0.79	99.5	7.84	0.52	0.66	0.82	91.4	8.91	0.52	0.67	0.84	82.2	10.1	0.52	0.69	0.88				
	3400	113.7	6.92	0.56	0.71	0.89	105.2	7.88	0.56	0.73	0.92	96.3	8.94	0.57	0.74	0.94	86.7	10.13	0.57	0.78	0.97				
	4080	118.2	6.94	0.6	0.77	0.96	109.4	7.89	0.6	0.8	0.97	100.1	8.97	0.61	0.83	0.99	90	10.15	0.62	0.87	1				
71°F	2720	115.5	6.93	0.39	0.51	0.63	107.4	7.89	0.38	0.51	0.64	98.9	8.96	0.37	0.51	0.65	89.3	10.15	0.35	0.51	0.67				
	3400	122.1	6.95	0.41	0.55	0.69	113.3	7.91	0.4	0.55	0.7	104	8.98	0.39	0.56	0.72	94.1	10.18	0.38	0.57	0.75				
	4080	126.5	6.96	0.42	0.58	0.75	117.6	7.93	0.41	0.59	0.77	108	9.01	0.41	0.6	0.8	97.5	10.2	0.4	0.62	0.85				

### 8.5 TON HEATING STANDARD EFFICIENCY ZHA102S4 - MSAV (Multi-Stage Air Volume) SUPPLY AIR BLOWER

Indoor Coil Air Volume 70°F Dry Bulb cfm	Air Temperature Entering Outdoor Coil									
	65°F		45°F		25°F		5°F		-15°F	
	Total Heating Capacity	Comp. Motor Input	Total Heating Capacity	Comp. Motor Input	Total Heating Capacity	Comp. Motor Input	Total Heating Capacity	Comp. Motor Input	Total Heating Capacity	Comp. Motor Input
	kBtuh	kW	kBtuh	kW	kBtuh	kW	kBtuh	kW	kBtuh	kW
2720	127.2	7.97	95.8	7.33	63.7	6.67	38.8	5.97	19.6	4.5
3400	129.4	7.45	98	6.81	65.9	6.15	41	5.44	21.7	3.98
4080	131.1	7.12	99.7	6.48	67.6	5.82	42.7	5.11	23.4	3.65

# RATINGS

NOTE - For Temperatures and Capacities not shown in tables, see bulletin - Cooling Unit Rating Table Correction Factor Data in Miscellaneous Engineering Data section.

## 10 TON COOLING STANDARD EFFICIENCY ZHA120S4 (1ST STAGE) - MSAV (Multi-Stage Air Volume) SUPPLY AIR BLOWER

Entering Wet Bulb Temperature	Total Air Volume	Outdoor Air Temperature Entering Outdoor Coil																			
		65°F					75°F					85°F					95°F				
		Total Cool Cap.	Comp. Motor Input	Sensible To Total Ratio (S/T) Dry Bulb			Total Cool Cap.	Comp. Motor Input	Sensible To Total Ratio (S/T) Dry Bulb			Total Cool Cap.	Comp. Motor Input	Sensible To Total Ratio (S/T) Dry Bulb			Total Cool Cap.	Comp. Motor Input	Sensible To Total Ratio (S/T) Dry Bulb		
				75°F	80°F	85°F			75°F	80°F	85°F			75°F	80°F	85°F			75°F	80°F	85°F
cfm	kBtuh	kW				kBtuh	kW				kBtuh	kW				kBtuh	kW				
63°F	2240	61.6	2.77	0.62	0.82	1	57.3	3.14	0.62	0.87	1	52.9	3.56	0.64	0.94	1	48.4	4.03	0.65	1	1
	2800	64.8	2.8	0.67	1	1	60.8	3.18	0.68	1	1	56.5	3.6	0.7	1	1	52.2	4.07	0.75	1	1
	3360	68.2	2.83	0.75	1	1	63.9	3.21	0.8	1	1	59.5	3.63	0.87	1	1	54.9	4.1	0.95	1	1
67°F	2240	65.8	2.81	0.48	0.6	0.74	61.3	3.19	0.48	0.61	0.8	56.7	3.6	0.48	0.62	0.86	51.8	4.07	0.48	0.63	0.94
	2800	68.4	2.83	0.51	0.65	0.96	63.8	3.21	0.52	0.67	1	58.9	3.63	0.52	0.69	1	53.9	4.09	0.53	0.71	1
	3360	70.4	2.86	0.55	0.71	1	65.7	3.23	0.55	0.76	1	60.8	3.65	0.56	0.82	1	55.6	4.11	0.57	0.91	1
71°F	2240	70.1	2.85	0.36	0.47	0.58	65.5	3.23	0.35	0.47	0.59	60.8	3.65	0.34	0.47	0.6	55.7	4.11	0.33	0.48	0.62
	2800	72.9	2.88	0.37	0.51	0.64	68.2	3.26	0.37	0.51	0.65	63.2	3.68	0.36	0.52	0.67	57.9	4.14	0.35	0.53	0.69
	3360	74.8	2.9	0.39	0.54	0.69	70	3.28	0.38	0.55	0.71	64.8	3.69	0.38	0.56	0.78	59.5	4.16	0.37	0.57	0.86

## 10 TON COOLING STANDARD EFFICIENCY ZHA120S4 (2ND STAGE) - MSAV (Multi-Stage Air Volume) SUPPLY AIR BLOWER

Entering Wet Bulb Temperature	Total Air Volume	Outdoor Air Temperature Entering Outdoor Coil																			
		85°F					95°F					105°F					115°F				
		Total Cool Cap.	Comp. Motor Input	Sensible To Total Ratio (S/T) Dry Bulb			Total Cool Cap.	Comp. Motor Input	Sensible To Total Ratio (S/T) Dry Bulb			Total Cool Cap.	Comp. Motor Input	Sensible To Total Ratio (S/T) Dry Bulb			Total Cool Cap.	Comp. Motor Input	Sensible To Total Ratio (S/T) Dry Bulb		
				75°F	80°F	85°F			75°F	80°F	85°F			75°F	80°F	85°F			75°F	80°F	85°F
cfm	kBtuh	kW				kBtuh	kW				kBtuh	kW				kBtuh	kW				
63°F	3200	118	7.62	0.68	0.84	0.99	108.4	8.63	0.69	0.86	1	98.3	9.77	0.7	0.89	1	87.3	11.08	0.72	0.94	1
	4000	125.3	7.68	0.75	0.93	1	115.3	8.69	0.76	0.96	1	104.8	9.83	0.79	0.99	1	94.1	11.14	0.81	1	1
	4800	131.2	7.74	0.81	1	1	121.4	8.75	0.83	1	1	111.7	9.9	0.86	1	1	101.1	11.23	0.9	1	1
67°F	3200	127.3	7.71	0.53	0.66	0.81	117.4	8.71	0.53	0.67	0.83	106.7	9.86	0.52	0.69	0.85	95.4	11.16	0.52	0.7	0.89
	4000	134.4	7.77	0.57	0.72	0.89	123.9	8.78	0.57	0.74	0.92	112.6	9.91	0.57	0.76	0.96	100.5	11.21	0.57	0.79	1
	4800	139.7	7.82	0.6	0.79	0.97	128.4	8.82	0.61	0.81	1	116.9	9.96	0.62	0.84	1	104.4	11.25	0.63	0.88	1
71°F	3200	136.7	7.79	0.39	0.52	0.64	126.4	8.8	0.38	0.52	0.65	115.4	9.94	0.36	0.52	0.66	103.7	11.24	0.34	0.52	0.68
	4000	143.9	7.86	0.41	0.56	0.7	133.1	8.86	0.4	0.56	0.72	121.5	10.01	0.39	0.57	0.74	109	11.29	0.37	0.58	0.77
	4800	149.1	7.92	0.43	0.6	0.77	137.8	8.92	0.42	0.6	0.79	125.4	10.05	0.41	0.61	0.82	112.4	11.35	0.4	0.63	0.86

## 10 TON HEATING STANDARD EFFICIENCY ZHA120S4 - MSAV (Multi-Stage Air Volume) SUPPLY AIR BLOWER

Indoor Coil Air Volume 70°F Dry Bulb cfm	Air Temperature Entering Outdoor Coil									
	65°F		45°F		25°F		5°F		-15°F	
	Total Heating Capacity	Comp. Motor Input	Total Heating Capacity	Comp. Motor Input	Total Heating Capacity	Comp. Motor Input	Total Heating Capacity	Comp. Motor Input	Total Heating Capacity	Comp. Motor Input
	kBtuh	kW	kBtuh	kW	kBtuh	kW	kBtuh	kW	kBtuh	kW
3200	145.4	9.22	112.8	8.29	79.6	7.31	51.1	6.44	25.3	4.9
4000	147.9	8.64	115.2	7.7	82.1	6.73	53.6	5.85	27.8	4.31
4800	149.8	8.28	117.1	7.34	84	6.37	55.5	5.49	29.7	3.95

## BLOWER DATA

### 092S STANDARD EFFICIENCY BELT DRIVE BLOWER – BASE UNIT

**BLOWER TABLE INCLUDES RESISTANCE FOR BASE UNIT ONLY (NO HEAT SECTION) WITH DRY INDOOR COIL AND AIR FILTERS IN PLACE. FOR ALL UNITS ADD:**

- 1 – Wet indoor coil air resistance of selected unit.
- 2 – Any factory installed options air resistance (heat section, economizer, etc.)
- 3 – Any field installed accessories air resistance (duct resistance, diffuser, etc.)

Then determine from blower table blower motor output required.

See page 23 for blower motors and drives.

See page 23 for wet coil and option/accessory air resistance data.

**MINIMUM AIR VOLUME REQUIRED FOR USE WITH OPTIONAL ELECTRIC HEAT (Maximum Static Pressure - 2.0 in. w.g.):**

7.5 kW, 15 kW, 22.5 kW - 2065 cfm

30 kW - 2250 cfm

45 kW - 3000 cfm

Total Air Volume cfm	Total Static Pressure – in. w.g.																										
	0.2		0.4		0.6		0.8		1.0		1.2		1.4		1.6		1.8		2.0		2.2		2.4		2.6		
	RPM	BHP	RPM	BHP	RPM	BHP	RPM	BHP	RPM	BHP	RPM	BHP	RPM	BHP	RPM	BHP	RPM	BHP	RPM	BHP	RPM	BHP	RPM	BHP	RPM	BHP	RPM
1750	494	0.11	562	0.34	632	0.56	702	0.74	771	0.85	838	0.96	902	1.07	961	1.19	---	---	---	---	---	---	---	---	---	---	---
2000	514	0.26	581	0.49	650	0.70	719	0.87	786	0.98	852	1.09	915	1.20	972	1.32	1026	1.47	1076	1.65	---	---	---	---	---	---	---
2250	533	0.41	599	0.62	667	0.82	735	0.99	802	1.10	866	1.21	928	1.33	984	1.46	1037	1.63	1085	1.81	1132	2.01	1178	2.21	1226	2.43	---
2500	553	0.55	619	0.76	685	0.95	753	1.10	818	1.22	881	1.34	942	1.47	997	1.62	1048	1.80	1096	1.99	1142	2.20	1188	2.41	1237	2.64	---
2750	573	0.70	638	0.90	705	1.08	771	1.22	835	1.35	897	1.49	957	1.63	1011	1.80	1061	1.99	1108	2.19	1154	2.41	1200	2.63	1249	2.87	---
3000	594	0.85	659	1.05	725	1.22	791	1.36	853	1.50	915	1.65	973	1.81	1026	1.99	1075	2.20	1121	2.42	1167	2.64	1213	2.87	1262	3.12	---
3250	617	1.01	682	1.20	747	1.37	812	1.52	873	1.67	934	1.83	990	2.01	1042	2.21	1089	2.43	1135	2.66	1181	2.90	1228	3.13	1277	3.38	---
3500	640	1.17	706	1.36	771	1.53	834	1.70	895	1.86	954	2.03	1008	2.23	1058	2.46	1105	2.69	1150	2.93	1196	3.17	1243	3.41	1293	3.65	---
3750	665	1.34	731	1.54	796	1.72	857	1.89	917	2.07	975	2.26	1027	2.48	1076	2.72	1121	2.97	1166	3.22	1212	3.46	1261	3.71	1311	3.96	---
4000	692	1.54	758	1.75	822	1.93	882	2.11	940	2.30	996	2.51	1047	2.76	1094	3.02	1139	3.27	1184	3.52	1230	3.77	1280	4.03	1330	4.29	---
4250	722	1.76	787	1.97	849	2.15	908	2.35	965	2.56	1018	2.79	1067	3.06	1113	3.33	1157	3.59	1202	3.85	1250	4.11	1300	4.38	1352	4.65	---

## BLOWER DATA

### 102 AND 120S STANDARD EFFICIENCY BELT DRIVE BLOWER – BASE UNIT

**BLOWER TABLE INCLUDES RESISTANCE FOR BASE UNIT ONLY (NO HEAT SECTION) WITH DRY INDOOR COIL AND AIR FILTERS IN PLACE. FOR ALL UNITS ADD:**

- 1 – Wet indoor coil air resistance of selected unit.
- 2 – Any factory installed options air resistance (heat section, economizer, etc.)
- 3 – Any field installed accessories air resistance (duct resistance, diffuser, etc.)

Then determine from blower table blower motor output required.

See page 23 for blower motors and drives.

See page 23 for wet coil and option/accessory air resistance data.

#### MINIMUM AIR VOLUME REQUIRED FOR USE WITH OPTIONAL ELECTRIC HEAT (Maximum Static Pressure - 2.0 in. w.g.)

15 kW, 22.5 kW- 2065 cfm

30 kW - 2250 cfm

45 kW - 3000 cfm

60 kW - 4000 cfm

Total Air Volume cfm	Total Static Pressure – in. w.g.																										
	0.2		0.4		0.6		0.8		1.0		1.2		1.4		1.6		1.8		2		2.2		2.4		2.6		
	RPM	BHP	RPM	BHP	RPM	BHP	RPM	BHP	RPM	BHP	RPM	BHP	RPM	BHP	RPM	BHP	RPM	BHP	RPM	BHP	RPM	BHP	RPM	BHP	RPM	BHP	RPM
2000	542	0.43	602	0.60	664	0.75	732	0.89	802	1.02	869	1.15	927	1.27	979	1.41	1029	1.57	1079	1.75	1129	1.95	1179	2.15	1230	2.37	
2250	560	0.55	619	0.71	681	0.86	748	1.00	817	1.14	882	1.27	939	1.41	991	1.57	1041	1.74	1090	1.93	1140	2.13	1190	2.35	1241	2.57	
2500	579	0.68	637	0.83	699	0.98	766	1.12	834	1.26	897	1.41	953	1.57	1005	1.74	1054	1.92	1103	2.12	1152	2.33	1202	2.55	1254	2.79	
2750	599	0.81	657	0.97	719	1.11	785	1.25	851	1.41	913	1.57	968	1.74	1020	1.93	1068	2.13	1116	2.34	1165	2.56	1215	2.78	1268	3.01	
3000	620	0.95	678	1.11	741	1.25	806	1.40	870	1.58	930	1.75	985	1.94	1036	2.14	1084	2.36	1131	2.58	1180	2.80	1230	3.02	1283	3.26	
3250	643	1.10	701	1.26	764	1.41	828	1.57	891	1.76	950	1.95	1003	2.16	1053	2.38	1100	2.61	1148	2.83	1196	3.06	1246	3.29	1299	3.52	
3500	667	1.26	726	1.43	788	1.58	851	1.77	913	1.97	970	2.17	1023	2.41	1071	2.65	1118	2.88	1165	3.11	1213	3.33	1264	3.57	1317	3.81	
3750	693	1.44	752	1.61	813	1.78	876	1.98	936	2.20	992	2.43	1043	2.68	1091	2.93	1137	3.17	1183	3.40	1232	3.64	1284	3.88	1338	4.13	
4000	720	1.65	779	1.82	840	2.00	902	2.22	961	2.46	1015	2.71	1064	2.98	1111	3.24	1156	3.48	1203	3.72	1253	3.96	1305	4.22	1359	4.48	
4250	748	1.86	807	2.04	868	2.24	929	2.48	986	2.75	1038	3.02	1086	3.30	1132	3.57	1177	3.81	1224	4.05	1274	4.31	1327	4.57	1382	4.85	
4500	778	2.09	837	2.28	898	2.51	957	2.78	1012	3.07	1062	3.37	1108	3.65	1154	3.92	1199	4.17	1247	4.41	1297	4.67	1350	4.94	1405	5.22	
4750	809	2.34	868	2.56	929	2.82	986	3.12	1038	3.43	1087	3.74	1132	4.03	1177	4.29	1223	4.54	1270	4.79	1321	5.04	1374	5.31	1428	5.58	
5000	841	2.62	901	2.87	960	3.17	1015	3.50	1065	3.83	1112	4.14	1157	4.43	1201	4.69	1247	4.94	1295	5.18	1345	5.42	1398	5.68	---	---	
5250	875	2.93	935	3.23	992	3.56	1044	3.91	1092	4.26	1138	4.57	1182	4.85	1226	5.10	1272	5.34	1320	5.57	---	---	---	---	---	---	
5500	911	3.30	969	3.63	1024	4.00	1074	4.37	1120	4.71	1165	5.02	1208	5.29	1253	5.53	---	---	---	---	---	---	---	---	---	---	
5750	948	3.71	1004	4.08	1056	4.48	1104	4.85	1148	5.19	1192	5.49	1235	5.74	---	---	---	---	---	---	---	---	---	---	---	---	
6000	985	4.18	1039	4.59	1088	5.00	1134	5.37	1177	5.69	---	---	---	---	---	---	---	---	---	---	---	---	---	---	---	---	
6250	1022	4.70	1073	5.14	1120	5.54	---	---	---	---	---	---	---	---	---	---	---	---	---	---	---	---	---	---	---	---	

## BLOWER DATA

### FACTORY INSTALLED BELT DRIVE KIT SPECIFICATIONS

Nominal hp	Maximum hp	Drive Kit Number	RPM Range
2	2.3	1	590 - 890
2	2.3	2	800 - 1105
2	2.3	3	795 - 1195
3	3.45	4	730 - 970
3	3.45	5	940 - 1200
3	3.45	6	1015 - 1300
5	5.75	10	900 - 1135
5	5.75	11	1040 - 1315
5	5.75	12	1125 - 1425

NOTE - Using total air volume and system static pressure requirements determine from blower performance tables rpm and motor output required. Maximum usable output of motors furnished are shown. In Canada, nominal motor output is also maximum usable motor output. If motors of comparable output are used, be sure to keep within the service factor limitations outlined on the motor nameplate.

NOTE - Units equipped with MSAV® (Multi-Stage Air Volume) option are limited to a motor service factor of 1.0.

### POWER EXHAUST FAN PERFORMANCE

Return Air System Static Pressure	Air Volume Exhausted
in. w.g.	cfm
0	3575
0.05	3405
0.10	3550
0.15	3245
0.20	3115
0.25	3020
0.30	2900
0.35	2785

### FACTORY INSTALLED OPTIONS/FIELD INSTALLED ACCESSORY AIR RESISTANCE - in. w.g.

Air Volume cfm	Wet Indoor Coil		Electric Heat	Economizer	Filters	
	092	102, 120			MERV 8	MERV 13
1750	0.03	0.04	0.03	0.03	0.01	0.03
2000	0.04	0.05	0.03	0.05	0.01	0.03
2250	0.05	0.06	0.04	0.06	0.01	0.04
2500	0.05	0.07	0.04	0.08	0.01	0.05
2750	0.06	0.08	0.05	0.09	0.02	0.05
3000	0.07	0.09	0.06	0.11	0.02	0.06
3250	0.08	0.10	0.06	0.13	0.02	0.06
3500	0.09	0.11	0.09	0.15	0.03	0.07
3750	0.10	0.13	0.09	0.17	0.03	0.08
4000	0.11	0.14	0.09	0.19	0.04	0.08
4250	0.13	0.15	0.13	0.21	0.04	0.09
4500	0.14	0.17	0.14	0.24	0.04	0.09
4750	0.15	0.18	0.17	0.26	0.05	0.10
5000	0.16	0.20	0.20	0.29	0.06	0.10
5250	0.17	0.22	0.22	0.32	0.06	0.11
5500	0.19	0.23	0.25	0.34	0.07	0.12
5750	0.20	0.25	0.31	0.37	0.07	0.12
6000	0.22	0.27	0.33	0.40	0.08	0.13

## BLOWER DATA

### CEILING DIFFUSERS AIR RESISTANCE - in. w.g.

Unit Size	RTD11 Step-Down Diffuser				FD11 Flush Diffuser
	Air Volume cfm	2 Ends Open	1 Side, 2 Ends Open	All Ends & Sides Open	
092 Models	2400	0.21	0.18	0.15	0.14
	2600	0.24	0.21	0.18	0.17
	2800	0.27	0.24	0.21	0.20
	3000	0.32	0.29	0.25	0.25
	3200	0.41	0.37	0.32	0.31
	3400	0.50	0.45	0.39	0.37
	3600	0.61	0.54	0.48	0.44
	3800	0.73	0.63	0.57	0.51
102 & 120 Models	3600	0.36	0.28	0.23	0.15
	3800	0.40	0.32	0.26	0.18
	4000	0.44	0.36	0.29	0.21
	4200	0.49	0.40	0.33	0.24
	4400	0.54	0.44	0.37	0.27
	4600	0.60	0.49	0.42	0.31
	4800	0.65	0.53	0.46	0.35
	5000	0.69	0.58	0.50	0.39
	5200	0.75	0.62	0.54	0.43

### CEILING DIFFUSER AIR THROW DATA

Model No.	Air Volume cfm	<sup>1</sup> Effective Throw Range	
		RTD11 Step-Down	FD11 Flush
		ft.	ft.
092 Models	2600	24 - 29	19 - 24
	2800	25 - 30	20 - 28
	3000	27 - 33	21 - 29
	3200	28 - 35	22 - 29
	3400	30 - 37	22 - 30
102, 120 Models	3600	25 - 33	22 - 29
	3800	27 - 35	22 - 30
	4000	29 - 37	24 - 33
	4200	32 - 40	26 - 35
	4400	34 - 42	28 - 37

<sup>1</sup> Throw is the horizontal or vertical distance an air stream travels on leaving the outlet or diffuser before the maximum velocity is reduced to 50 ft. per minute. Four sides open.



**ELECTRICAL/ELECTRIC HEAT DATA**

**7.5 TON**

**7.5 TON STANDARD EFFICIENCY**

**ZHA092S4**

<sup>1</sup> Voltage - 60hz		208/230V - 3 Ph			460V - 3 Ph			575V - 3 Ph		
Compressor 1	Rated Load Amps	13.5			8			5		
	Locked Rotor Amps	109			59			40		
Compressor 2	Rated Load Amps	8.7			4			3.6		
	Locked Rotor Amps	70			31			27		
Outdoor Fan Motors (2)	Full Load Amps	2.4			1.3			1.0		
	(total)	(4.8)			(2.6)			(2.0)		
Power Exhaust (2) 0.5 HP	Full Load Amps	1.5			0.6			0.6		
	(total)	(3.0)			(1.2)			(1.2)		
Indoor Blower Motor	Horsepower	2	3	5	2	3	5	2	3	5
	Full Load Amps	7.5	10.6	16.7	3.4	4.8	7.6	2.7	3.9	6.1
<sup>2</sup> Maximum Overcurrent Protection	Unit Only	50	50	60	25	25	30	15	20	20
	With (2) 0.5 HP Power Exhaust	50	50	60	25	30	30	20	20	25
<sup>3</sup> Minimum Circuit Ampacity	Unit Only	38	41	48	20	22	25	15	16	19
	With (2) 0.5 HP Power Exhaust	41	44	51	22	23	26	16	17	20

**ELECTRIC HEAT DATA**

Electric Heat Voltage			208V	240V	208V	240V	208V	240V	480V	480V	480V	600V	600V	600V
<sup>2</sup> Maximum Overcurrent Protection	Unit+	<b>7.5 kW</b>	<sup>4</sup> 60	70	70	70	80	80	35	35	40	25	25	30
	Electric Heat	<b>15 kW</b>	<sup>4</sup> 80	90	90	90	<sup>4</sup> 90	100	45	45	50	35	35	40
		<b>22.5 kW</b>	<sup>4</sup> 100	110	<sup>4</sup> 100	110	<sup>4</sup> 110	125	60	60	60	45	45	50
		<b>30 kW</b>	<sup>4</sup> 125	150	<sup>4</sup> 125	150	150	150	70	70	70	60	60	60
		<b>45 kW</b>	175	175	<sup>4</sup> 175	200	<sup>4</sup> 175	200	90	90	100	70	70	80
<sup>3</sup> Minimum Circuit Ampacity	Unit+	<b>7.5 kW</b>	58	61	61	64	68	71	32	33	36	24	25	28
	Electric Heat	<b>15 kW</b>	77	83	81	87	87	93	43	44	47	33	34	37
		<b>22.5 kW</b>	97	106	100	109	107	116	54	56	59	42	43	46
		<b>30 kW</b>	117	129	120	132	127	139	66	67	70	51	52	55
		<b>45 kW</b>	156	174	159	177	166	184	88	90	92	69	70	73
<sup>2</sup> Maximum Overcurrent Protection	Unit+	<b>7.5 kW</b>	70	70	70	70	80	80	35	35	40	25	30	30
	Electric Heat and (2) 0.5 HP Power Exhaust	<b>15 kW</b>	<sup>4</sup> 80	90	90	90	<sup>4</sup> 90	100	45	50	50	35	35	40
		<b>22.5 kW</b>	<sup>4</sup> 100	110	<sup>4</sup> 110	125	<sup>4</sup> 110	125	60	60	60	45	45	50
		<b>30 kW</b>	<sup>4</sup> 125	150	<sup>4</sup> 125	150	150	150	70	70	80	60	60	60
		<b>45 kW</b>	<sup>4</sup> 175	200	<sup>4</sup> 175	200	<sup>4</sup> 175	200	90	100	100	70	80	80
<sup>3</sup> Minimum Circuit Ampacity	Unit+	<b>7.5 kW</b>	61	64	64	67	71	74	33	34	37	25	26	29
	Electric Heat and (2) 0.5 HP Power Exhaust	<b>15 kW</b>	80	86	84	90	90	96	44	46	48	34	35	38
		<b>22.5 kW</b>	100	109	103	112	110	119	56	57	60	43	45	47
		<b>30 kW</b>	120	132	123	135	130	142	67	68	71	52	54	56
		<b>45 kW</b>	159	177	162	180	169	187	89	91	94	70	72	74

**ELECTRIC HEAT ACCESSORIES**

Unit Fuse Block	Unit Only	<b>11M12</b>	<b>11M12</b>	<b>11M12</b>	<b>11M12</b>	<b>11M12</b>	<b>11M12</b>	<b>11M10</b>	<b>11M10</b>	<b>11M10</b>	<b>11M09</b>	<b>11M09</b>	<b>11M09</b>
	Unit + Power Exhaust	<b>11M12</b>	<b>11M12</b>	<b>11M12</b>	<b>11M12</b>	<b>11M13</b>	<b>11M13</b>	<b>11M10</b>	<b>11M10</b>	<b>11M11</b>	<b>11M09</b>	<b>11M09</b>	<b>11M10</b>

NOTE - All units have a minimum Short Circuit Current Rating (SCCR) of 5000 amps.

<sup>1</sup> Extremes of operating range are plus and minus 10% of line voltage.

<sup>2</sup> HACR type breaker or fuse.

<sup>3</sup> Refer to National or Canadian Electrical Code manual to determine wire, fuse and disconnect size requirements.

<sup>4</sup> Factory installed circuit breaker not available.

# ELECTRICAL/ELECTRIC HEAT DATA

8.5 TON

## 8.5 TON STANDARD EFFICIENCY

ZHA102S4

<sup>1</sup> Voltage - 60hz		208/230V - 3 Ph			460V - 3 Ph			575V - 3 Ph		
Compressor 1	Rated Load Amps	13.5			8			5		
	Locked Rotor Amps	109			59			40		
Compressor 2	Rated Load Amps	11			5.5			4.7		
	Locked Rotor Amps	86			37			34		
Outdoor Fan Motors (2)	Full Load Amps	2.4			1.3			1.0		
	(total)	(4.8)			(2.6)			(2.0)		
Power Exhaust (2) 0.5 HP	Full Load Amps	1.5			0.6			0.6		
	(total)	(3.0)			(1.2)			(1.2)		
Indoor Blower Motor	Horsepower	2	3	5	2	3	5	2	3	5
	Full Load Amps	7.5	10.5	16.7	3.4	4.8	7.6	2.7	3.9	6.1
<sup>2</sup> Maximum Overcurrent Protection	Unit Only	50	50	60	25	30	30	20	20	25
	With (2) 0.5 HP Power Exhaust	50	50	60	30	30	30	20	20	25
<sup>3</sup> Minimum Circuit Ampacity	Unit Only	41	44	51	22	23	26	16	17	20
	With (2) 0.5 HP Power Exhaust	44	47	54	23	25	27	17	19	21

## ELECTRIC HEAT DATA

Electric Heat Voltage			208V	240V	208V	240V	208V	240V	480V	480V	480V	600V	600V	600V
<sup>2</sup> Maximum Overcurrent Protection	Unit+ 7.5 kW	Electric Heat	<sup>4</sup> 60	70	70	70	80	80	35	35	40	25	30	30
	15 kW		<sup>4</sup> 80	90	90	90	<sup>4</sup> 90	100	45	50	50	35	35	40
	22.5 kW		<sup>4</sup> 100	110	<sup>4</sup> 110	125	<sup>4</sup> 110	125	60	60	60	45	45	50
	30 kW		<sup>4</sup> 125	150	<sup>4</sup> 125	150	150	150	70	70	80	60	60	60
	45 kW		<sup>4</sup> 175	200	<sup>4</sup> 175	200	<sup>4</sup> 175	200	90	100	100	70	80	80
<sup>3</sup> Minimum Circuit Ampacity	Unit+ 7.5 kW	Electric Heat	60	63	63	66	70	73	33	35	37	25	26	29
	15 kW		80	86	83	89	90	96	45	46	49	34	35	38
	22.5 kW		99	108	102	111	109	118	56	57	60	43	44	47
	30 kW		119	131	122	134	129	141	67	69	71	52	53	56
	45 kW		158	176	161	179	168	186	90	91	94	70	71	74
<sup>2</sup> Maximum Overcurrent Protection	Unit+ 7.5 kW	Electric Heat and (2) 0.5 HP Power Exhaust	70	70	70	70	80	80	35	40	40	30	30	30
	15 kW		90	90	<sup>4</sup> 90	100	100	100	50	50	50	35	40	40
	22.5 kW		<sup>4</sup> 110	125	<sup>4</sup> 110	125	125	125	60	60	70	45	50	50
	30 kW		<sup>4</sup> 125	150	<sup>4</sup> 125	150	150	150	70	70	80	60	60	60
	45 kW		<sup>4</sup> 175	200	<sup>4</sup> 175	200	<sup>4</sup> 175	200	100	100	100	80	80	80
<sup>3</sup> Minimum Circuit Ampacity	Unit+ 7.5 kW	Electric Heat and (2) 0.5 HP Power Exhaust	63	66	66	69	73	76	34	36	39	26	28	30
	15 kW		83	89	86	92	93	99	46	47	50	35	37	39
	22.5 kW		102	111	105	114	112	121	57	58	61	44	46	48
	30 kW		122	134	125	137	132	144	68	70	73	53	55	57
	45 kW		161	179	164	182	171	189	91	92	95	71	73	75

## ELECTRIC HEAT ACCESSORIES

Unit Fuse Block	Unit Only	11M12	11M12	11M12	11M12	11M12	11M12	11M10	11M10	11M10	11M09	11M09	11M10
	Unit + Power Exhaust	11M12	11M12	11M12	11M12	11M13	11M13	11M10	11M10	11M11	11M09	11M10	11M10

NOTE - All units have a minimum Short Circuit Current Rating (SCCR) of 5000 amps.

<sup>1</sup> Extremes of operating range are plus and minus 10% of line voltage.

<sup>2</sup> HACR type breaker or fuse.

<sup>3</sup> Refer to National or Canadian Electrical Code manual to determine wire, fuse and disconnect size requirements.

**ELECTRICAL/ELECTRIC HEAT DATA**

**10 TON**

**10 TON STANDARD EFFICIENCY**

**ZHA120S4**

<sup>1</sup> Voltage - 60hz		208/230V - 3 Ph			460V - 3 Ph			575V - 3 Ph		
Compressor 1	Rated Load Amps	15.6			7.8			5.8		
	Locked Rotor Amps	110			52			38.9		
Compressor 2	Rated Load Amps	15.6			7.8			5.8		
	Locked Rotor Amps	110			52			38.9		
Outdoor Fan Motors (2)	Full Load Amps	3.0			1.5			1.2		
	(total)	(6.0)			(3.0)			(2.4)		
Power Exhaust (2) 0.5 HP	Full Load Amps	1.5			0.6			0.6		
	(total)	(3.0)			(1.2)			(1.2)		
Indoor Blower Motor	Horsepower	2	3	5	2	3	5	2	3	5
	Full Load Amps	7.5	10.6	16.7	3.4	4.8	7.6	2.7	3.9	6.1
<sup>2</sup> Maximum Overcurrent Protection	Unit Only	60	60	70	30	30	35	20	25	25
	With (2) 0.5 HP Power Exhaust	60	70	70	30	30	35	25	25	25
<sup>3</sup> Minimum Circuit Ampacity	Unit Only	49	52	59	24	26	29	19	20	22
	With (2) 0.5 HP Power Exhaust	52	55	62	26	27	30	20	21	23

**ELECTRIC HEAT DATA**

Electric Heat Voltage			208V	240V	208V	240V	208V	240V	480V	480V	480V	600V	600V	600V
<sup>2</sup> Maximum Overcurrent Protection	Unit+	15 kW	<sup>4</sup> 90	100	100	100	<sup>4</sup> 100	110	50	50	60	40	40	40
	Electric Heat	22.5 kW	<sup>4</sup> 110	125	125	125	<sup>4</sup> 125	150	60	60	70	50	50	50
		30 kW	150	150	150	150	150	150	70	80	80	60	60	60
		45 kW	<sup>4</sup> 175	200	<sup>4</sup> 175	200	200	200	100	100	100	80	80	80
		60 kW	<sup>4</sup> 175	200	200	200	<sup>4</sup> 200	225	100	100	110	80	80	80
<sup>3</sup> Minimum Circuit Ampacity	Unit+	15 kW	88	94	91	97	98	104	47	48	51	37	38	40
	Electric Heat	22.5 kW	108	117	111	120	117	126	58	60	62	46	47	49
		30 kW	127	139	130	142	137	149	70	71	74	55	56	58
		45 kW	166	184	169	188	176	194	92	94	96	73	74	76
		60 kW	174	193	177	197	184	203	97	98	101	76	78	80
<sup>2</sup> Maximum Overcurrent Protection	Unit+	15 kW	100	100	100	100	110	110	50	50	60	40	40	45
	Electric Heat and (2) 0.5 HP Power Exhaust	22.5 kW	125	125	125	125	<sup>4</sup> 125	150	60	70	70	50	50	50
		30 kW	150	150	150	150	<sup>4</sup> 150	175	80	80	80	60	60	60
		45 kW	<sup>4</sup> 175	200	<sup>4</sup> 175	200	200	200	100	100	100	80	80	80
		60 kW	200	200	200	200	<sup>4</sup> 200	225	100	100	110	80	80	90
<sup>3</sup> Minimum Circuit Ampacity	Unit+	15 kW	91	97	94	100	101	107	48	50	52	38	39	41
	Electric Heat and (2) 0.5 HP Power Exhaust	22.5 kW	111	120	114	123	120	129	59	61	64	47	48	50
		30 kW	130	142	133	145	140	152	71	72	75	56	57	59
		45 kW	169	187	172	191	179	197	93	95	98	74	75	77
		60 kW	177	196	180	200	187	206	98	99	102	78	79	81

**ELECTRIC HEAT ACCESSORIES**

Unit Fuse Block	Unit Only	11M12	11M12	11M12	11M12	11M12	11M12	11M12	11M10	11M10	11M11	11M09	11M09	11M10
	Unit + Power Exhaust	11M12	11M12	11M12	11M12	11M13	11M13	11M11	11M11	11M11	11M09	11M10	11M10	11M10

NOTE - All units have a minimum Short Circuit Current Rating (SCCR) of 5000 amps.

<sup>1</sup> Extremes of operating range are plus and minus 10% of line voltage.

<sup>2</sup> HACR type breaker or fuse.

<sup>3</sup> Refer to National or Canadian Electrical Code manual to determine wire, fuse and disconnect size requirements.

## ELECTRIC HEAT CAPACITIES

Volts Input	7.5 kW			15 kW			22.5 kW			30 kW			45 kW			60 kW		
	kW Input	Btuh Output	No. of Stages	kW Input	Btuh Output	No. of Stages	kW Input	Btuh Output	No. of Stages	kW Input	Btuh Output	No. of Stages	kW Input	Btuh Output	No. of Stages	kW Input	Btuh Output	No. of Stages
208	5.6	19,100	1	11.3	38,600	1	16.9	57,700	1	22.5	76,800	1	33.8	115,300	1	45.0	153,600	1
220	6.3	21,500	1	12.6	43,000	1	18.9	64,500	1	25.2	86,000	1	37.8	129,000	1	50.4	172,000	1
230	6.9	23,600	1	13.8	47,100	1	20.7	70,700	1	27.5	93,900	1	41.3	141,000	1	55.1	188,000	1
240	7.5	25,600	1	15.0	51,200	1	22.5	76,800	1	30.0	102,400	1	45.0	153,600	1	60.0	204,800	1
440	6.9	21,500	1	12.6	43,000	1	18.9	64,500	1	25.2	86,000	1	37.8	129,000	1	50.4	172,000	1
460	6.9	23,600	1	13.8	47,100	1	20.7	70,700	1	27.5	93,900	1	41.3	141,000	1	55.1	188,000	1
480	7.5	25,600	1	15.0	51,200	1	22.5	76,800	1	30.0	102,400	1	45.0	153,600	1	60.0	204,800	1
550	6.3	21,500	1	12.6	43,000	1	18.9	64,500	1	25.2	86,000	1	37.8	129,000	1	50.4	172,000	1
575	6.9	23,600	1	13.8	47,100	1	20.7	70,700	1	27.5	93,900	1	41.3	141,000	1	55.1	188,000	1
600	7.5	25,600	1	15.0	51,200	1	22.5	76,800	2	30.0	102,400	2	45.0	153,600	2	60.0	204,800	1

## UNIT CLEARANCES

### UNIT WITH ECONOMIZER

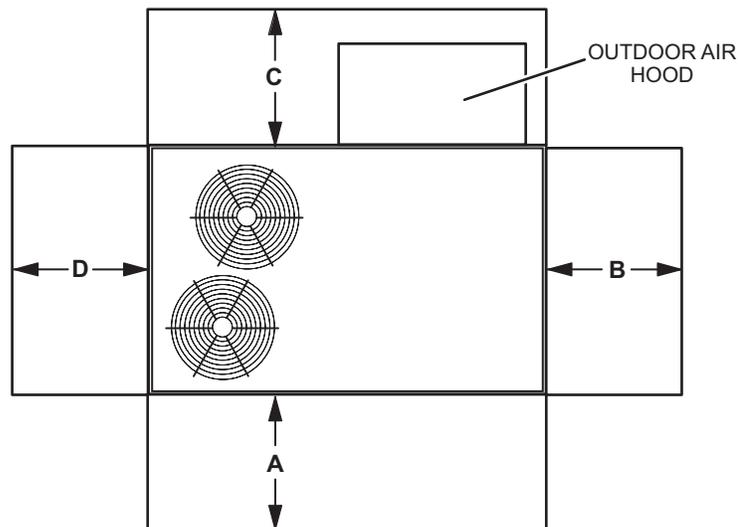

<sup>1</sup> Unit Clearance	A		B		C		D		Top Clearance
	in.	mm	in.	mm	in.	mm	in.	mm	
Service Clearance	60	1524	36	914	36	914	60	1524	Unobstructed
Minimum Operation Clearance	36	914	36	914	36	914	36	914	

NOTE - Entire perimeter of unit base requires support when elevated above the mounting surface.

<sup>1</sup> Service Clearance - Required for removal of serviceable parts.

Minimum Operation Clearance - Required clearance for proper unit operation.

## OUTDOOR SOUND DATA

Unit Model Number	Octave Band Sound Power Levels dBA, re 10 <sup>-12</sup> Watts - Center Frequency - Hz							<sup>1</sup> Sound Rating Number (dBA)
	125	250	500	1000	2000	4000	8000	
092, 102	76	79	84	83	79	73	66	88
120	77	80	85	84	79	74	66	88

<sup>1</sup> Sound Rating Number according to AHRI Standard 270-2008. Sound Rating Number is the overall A-Weighted Sound Power Level, (LWA), dB (100 Hz to 10,000 Hz).

**WEIGHT DATA**

Model Number	Net		Shipping	
	lbs.	kg	lbs.	kg
092S Base Unit	1036	470	1121	508
092S Max. Unit	1193	541	1278	580
102S Base Unit	1068	484	1153	523
102S Max. Unit	1225	556	1310	594
120S Base Unit	1126	511	1211	549
120S Max. Unit	1290	585	1375	624

**OPTIONS / ACCESSORIES**

Model Number	Shipping Weight	
	lbs.	kg

**CABINET**

Coil/Hail Guard	50	23
-----------------	----	----

**CEILING DIFFUSERS**

Step-Down		
RTD11-95S	118	54
RTD11-135S	135	61
Flush		
FD11-95S	118	54
FD11-135S	135	61

**ECONOMIZER / OUTDOOR AIR / EXHAUST****Economizer**

Downflow with Barometric Relief Dampers and Hoods	90	41
Horizontal with Barometric Relief Dampers and Hoods	95	43
Horizontal Low Profile Barometric Relief Dampers with Hood	8	4

**Outdoor Air Dampers**

Outdoor Air Damper Section with Hood - Automatic	44	20
Outdoor Air Damper Section with Hood - Manual	27	12

**Power Exhaust**

Downflow	60	27
Horizontal	41	19

**ELECTRIC HEAT**

7.5 kW	90	41
15 kW	90	41
22.5 kW	90	41
30 kW	90	41
45 kW	90	41
60 kW	90	41

**MSAV® (MULTI-STAGE AIR VOLUME) SUPPLY AIR BLOWER OPTION**

Variable Frequency Drive (VFD) and associated components	10	5
--	----	---

**ROOF CURBS****Hybrid Roof Curbs, Downflow**

8 in. height	79	36
14 in. height	104	47
18 in. height	120	54
24 in. height	145	66

**PACKAGING**

LTL Packaging (less than truck load)	105	48
--------------------------------------	-----	----

# DIMENSIONS - UNIT

Model No.	CORNER WEIGHTS														CENTER OF GRAVITY									
	AA				BB				CC				DD				EE				FF			
	Base		Max.		Base		Max.		Base		Max.		Base		Max.		Base		Max.		Base		Max.	
	lbs.	kg	lbs.	kg	lbs.	kg	lbs.	kg	lbs.	kg	lbs.	kg	lbs.	kg	lbs.	kg	in.	mm	in.	mm	in.	mm	in.	mm
092S	276	125	315	143	226	103	276	125	240	109	281	127	294	133	321	146	46.25	1174	47.25	1200	27	686	28	711
102S	285	129	324	147	233	106	283	128	248	112	289	131	303	137	330	150	46.25	1174	47.25	1200	27	686	285	711
120S	283	128	322	146	228	103	277	126	274	124	320	145	341	155	372	169	43.25	1099	43.25	1099	26.75	679	27.75	705

Base Unit - The unit with NO OPTIONS.

Max. Unit - The unit with ALL OPTIONS Installed. (Economizer, etc.)

## BOTTOM POWER ENTRY

Holes required for Optional Bottom Power Entry Kit

	Threaded Conduit Fittings (Provided in Kit)	Wire Use	Hole Diameter Required in Unit Base (Max.)
<b>A</b>	<sup>1</sup> 1/2	ACC	7/8 (23)
<b>B</b>	1/2	24V	7/8 (23)
<b>C</b>	1-1/4	POWER	1-3/4 (44)

<sup>1</sup> Field provided.

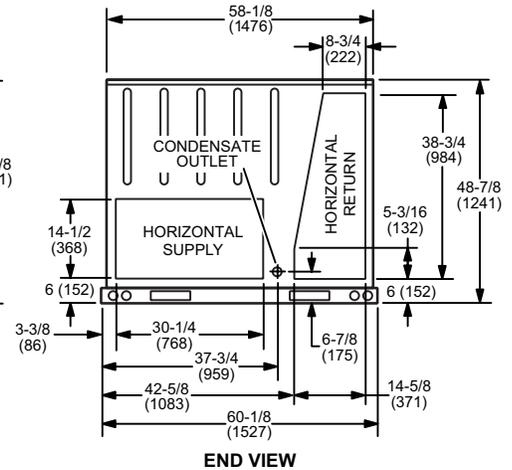
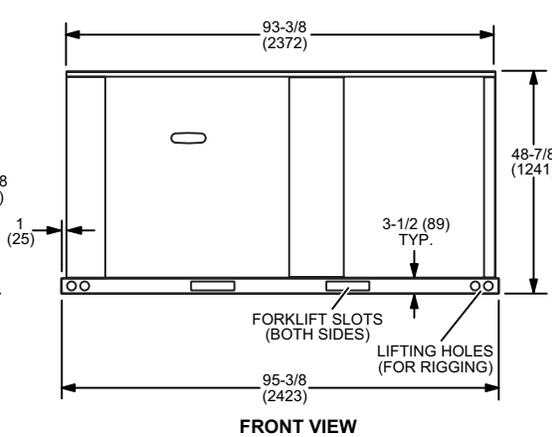
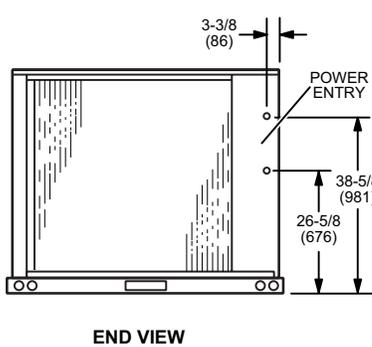
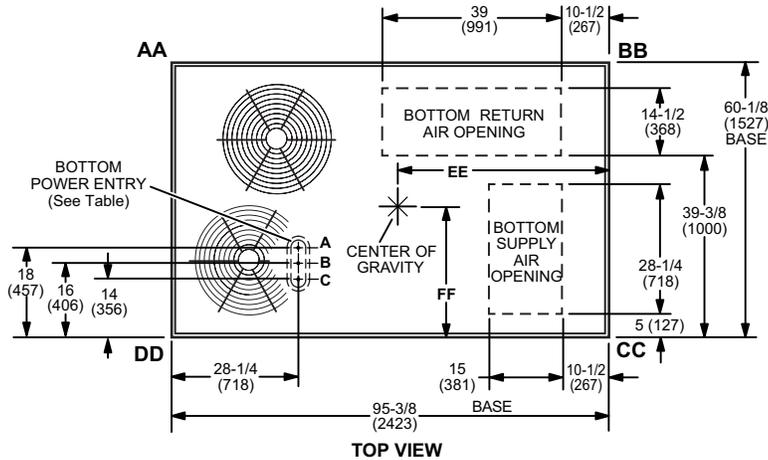

## DIMENSIONS - ACCESSORIES

### OUTDOOR AIR HOOD DETAIL FOR OPTIONAL DOWNFLOW ECONOMIZER (Downflow Applications)

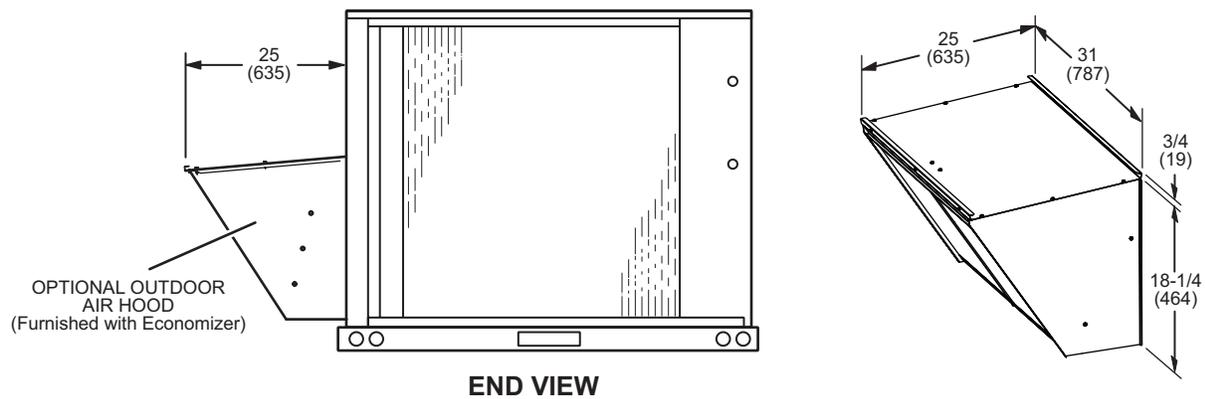

### OUTDOOR AIR DAMPER HOOD DETAIL FOR OPTIONAL MANUAL OR MOTORIZED OUTDOOR AIR DAMPERS (Downflow or Horizontal Applications)

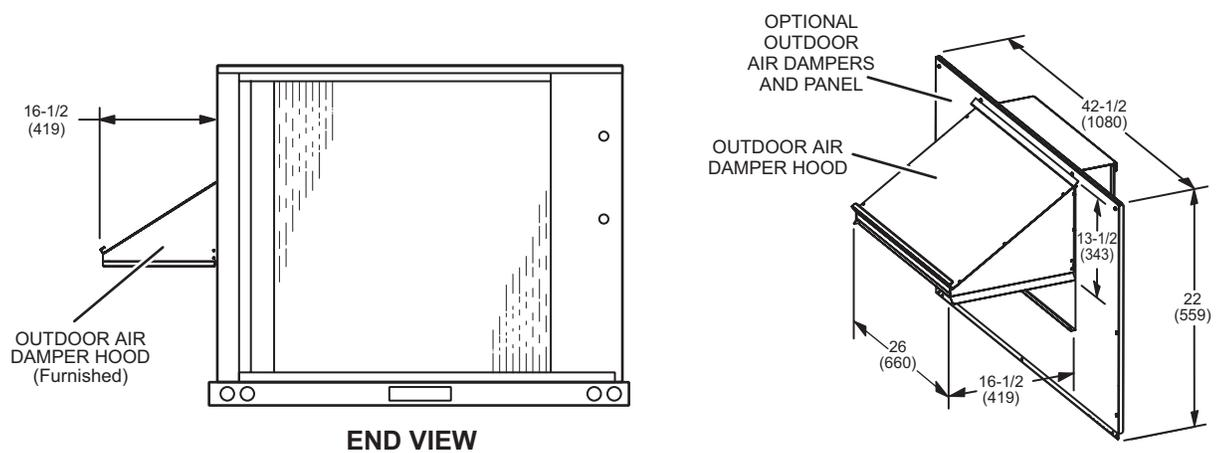

## DIMENSIONS - ACCESSORIES

### OUTDOOR AIR HOOD DETAIL WITH OPTIONAL HORIZONTAL ECONOMIZER AND BAROMETRIC RELIEF DAMPERS (Horizontal Applications)

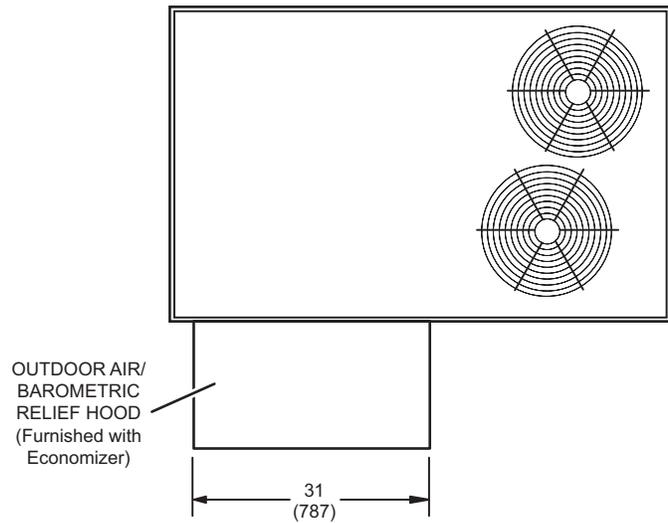

**TOP VIEW**

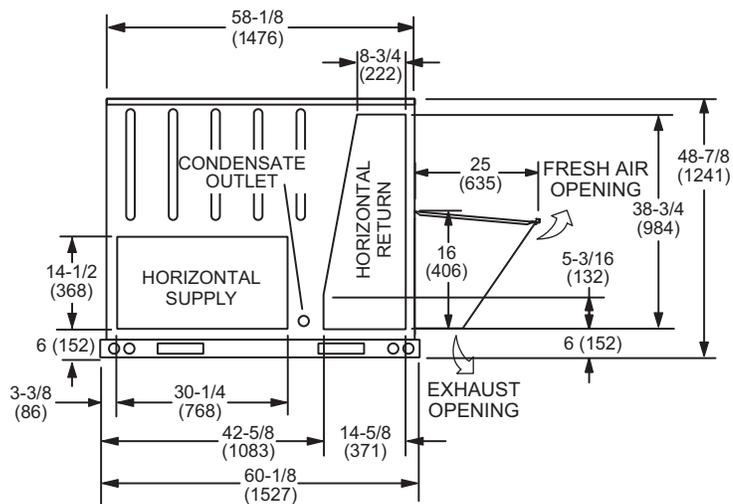

**END VIEW**

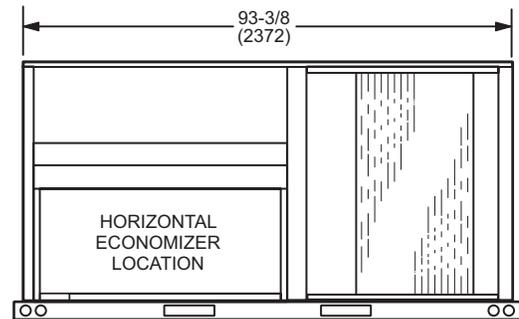

**BACK VIEW**

Note - Supply and Return Air Ducts must be supported.



# DIMENSIONS - ACCESSORIES

## HYBRID CURBS - DOUBLE DUCT OPENING

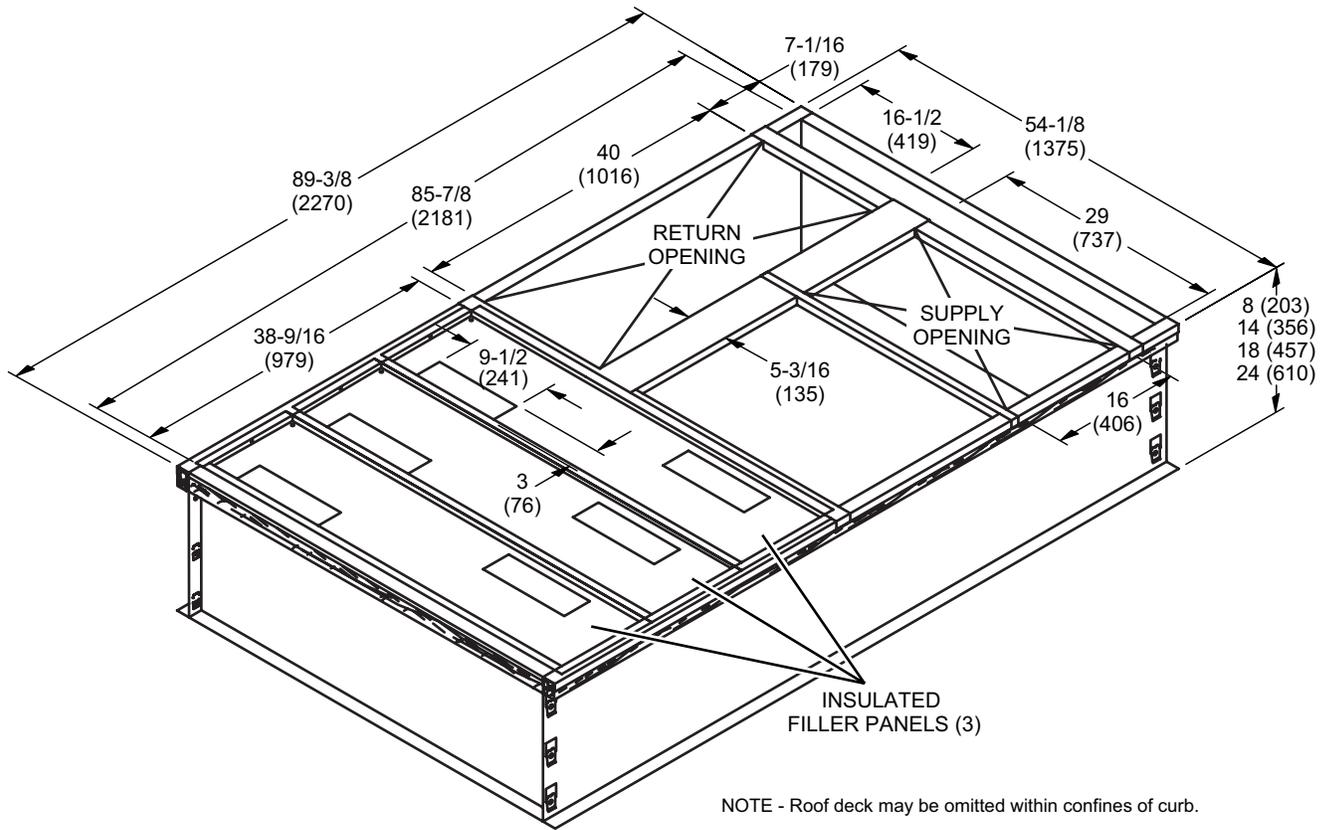

### TYPICAL FLASHING DETAIL FOR ROOF CURB

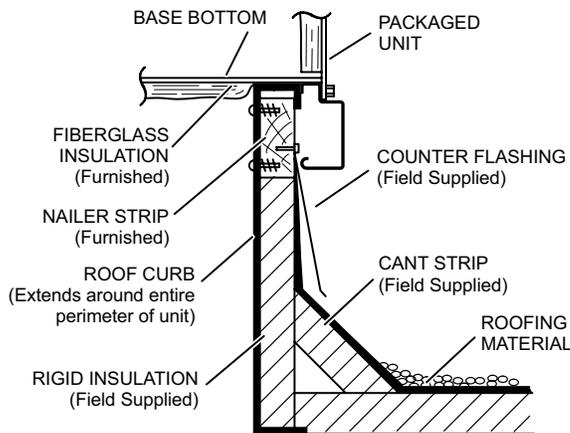

### DETAIL ROOF CURB

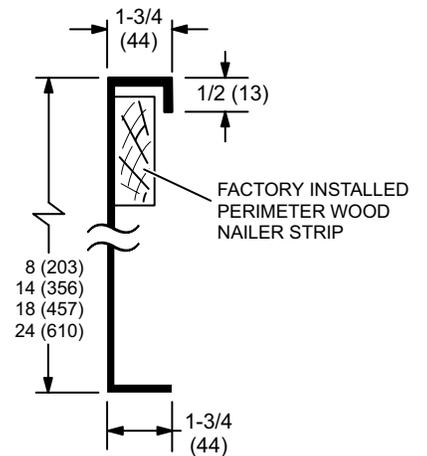

## DIMENSIONS - ACCESSORIES

### COMBINATION CEILING SUPPLY AND RETURN DIFFUSERS

#### STEP-DOWN CEILING DIFFUSER

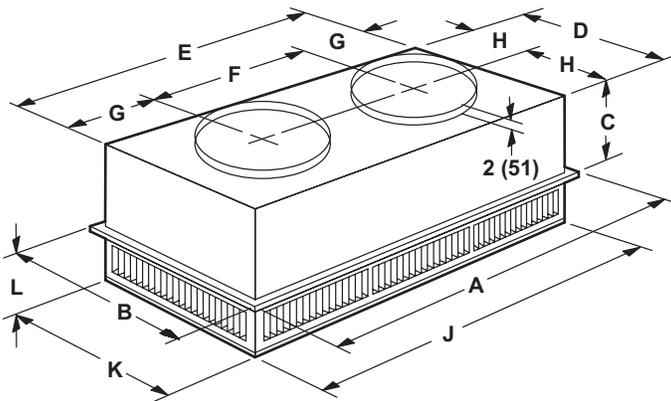

#### FLUSH CEILING DIFFUSER

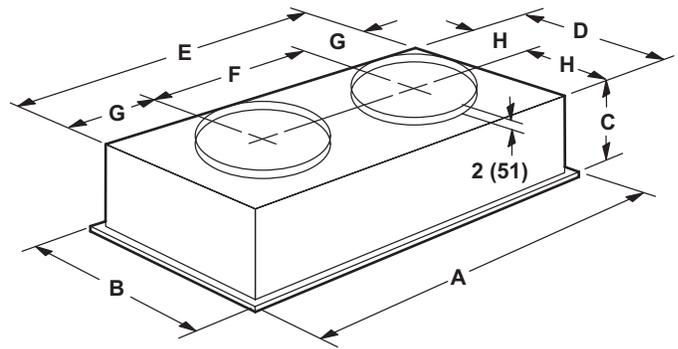

Model Number		RTD11-95S
A	in.	47-5/8
	mm	1159
B	in.	29-5/8
	mm	752
C	in.	14-3/8
	mm	365
D	in.	27-1/2
	mm	699
E	in.	45-1/2
	mm	1158
F	in.	22-1/2
	mm	572
G	in.	11-1/2
	mm	292
H	in.	13-3/4
	mm	349
J	in.	45-1/2
	mm	1156
K	in.	27-1/2
	mm	699
L	in.	8-1/8
	mm	206
Duct Size	in.	20 round
	mm	508 round

Model Number		FD11-95S
A	in.	47-5/8
	mm	1159
B	in.	29-5/8
	mm	752
C	in.	16-5/8
	mm	422
D	in.	27
	mm	686
E	in.	45
	mm	1143
F	in.	22-1/2
	mm	572
G	in.	11-1/4
	mm	286
H	in.	13-1/2
	mm	343
Duct Size	in.	20 round
	mm	508 round

## DIMENSIONS - ACCESSORIES

### COMBINATION CEILING SUPPLY AND RETURN DIFFUSERS

#### STEP-DOWN CEILING DIFFUSER

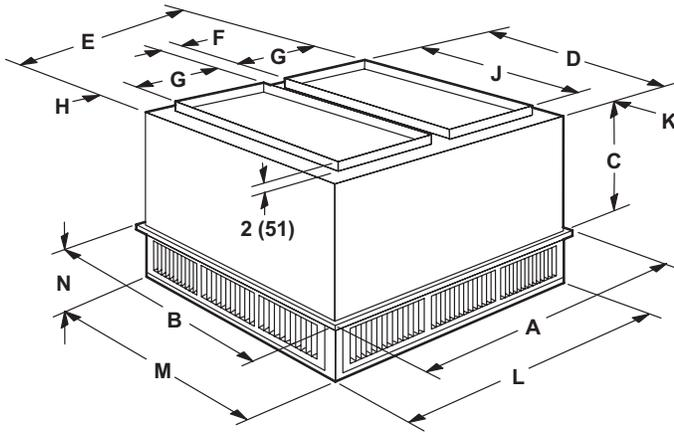

#### FLUSH CEILING DIFFUSER

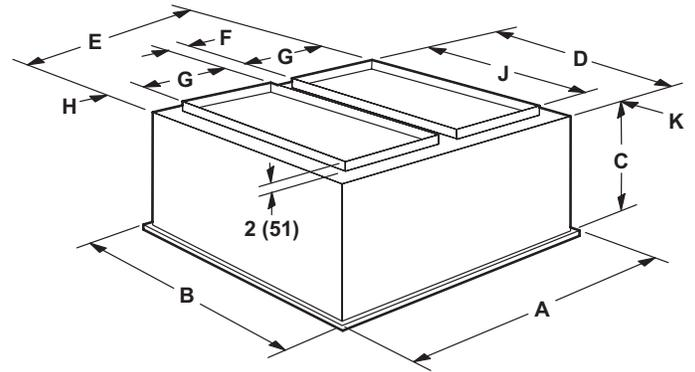

Model Number		RTD11-135S
A	in.	47-5/8
	mm	1210
B	in.	35-5/8
	mm	905
C	in.	20-5/8
	mm	524
D	in.	33-1/2
	mm	851
E	in.	45-1/2
	mm	1156
F	in.	4-1/2
	mm	114
G	in.	18
	mm	457
H	in.	2-1/2
	mm	64
J	in.	28
	mm	711
K	in.	2-3/4
	mm	70
L	in.	45-1/2
	mm	1156
M	in.	33-1/2
	mm	851
N	in.	9-1/8
	mm	232
Duct Size	in.	18 x 28
	mm	457 x 711

Model Number		FD11-135S
A	in.	47-5/8
	mm	1210
B	in.	35-5/8
	mm	905
C	in.	23-1/4
	mm	591
D	in.	33
	mm	838
E	in.	45
	mm	1143
F	in.	4-1/2
	mm	114
G	in.	18
	mm	457
H	in.	2-1/4
	mm	57
J	in.	28
	mm	711
K	in.	2-1/2
	mm	64
Duct Size	in.	18 x 28
	mm	457 x 711

## REVISIONS

Sections	Description of Change
Options/Accessories	<b>Catalog numbers revised for:</b> Condensate Drain Trap Economizers Single Enthalpy



Visit us at [www.lennox.com](http://www.lennox.com)

For the latest technical information, [www.lennoxcommercial.com](http://www.lennoxcommercial.com)

Contact us at 1-800-4-LENNOX

NOTE - Due to Lennox' ongoing commitment to quality, Specifications, Ratings and Dimensions subject to change without notice and without incurring liability. Improper installation, adjustment, alteration, service or maintenance can cause property damage or personal injury. Installation and service must be performed by a qualified installer and servicing agency.

©2021 Lennox Industries, Inc.