

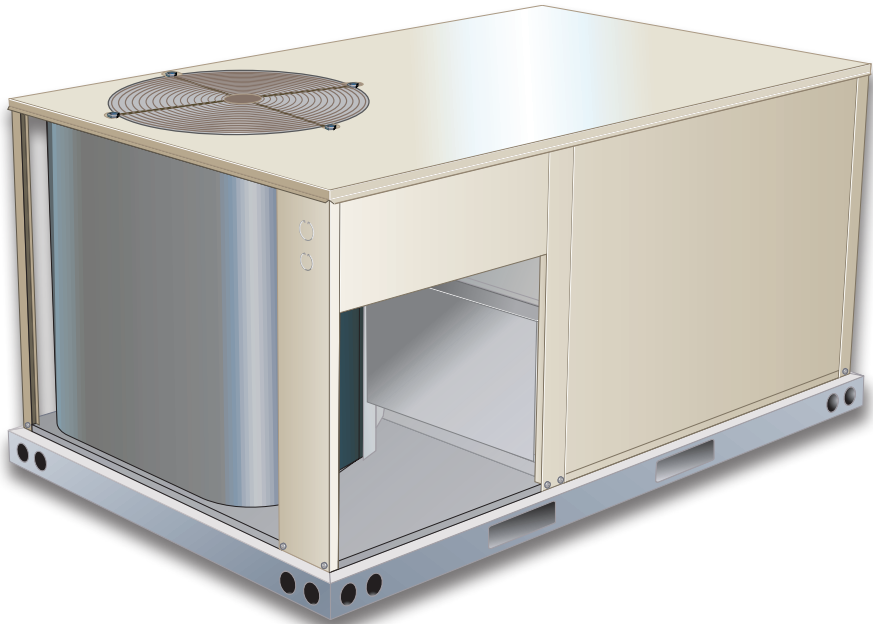

ZHB
Raider® Rooftop Units
60 Hz

**COMMERCIAL
PRODUCT SPECIFICATIONS**

Bulletin No. 210954
January 2021
Supersedes 210749



RAIDER®
Value Without Compromise™



**ASHRAE 90.1
COMPLIANT**

3 to 6 Tons
Net Cooling Capacity - 35,000 to 69,000 Btuh
Net Heating Capacity - 34,200 to 70,000 Btuh
Optional Electric Heat - 5 to 30 kW

MODEL NUMBER IDENTIFICATION

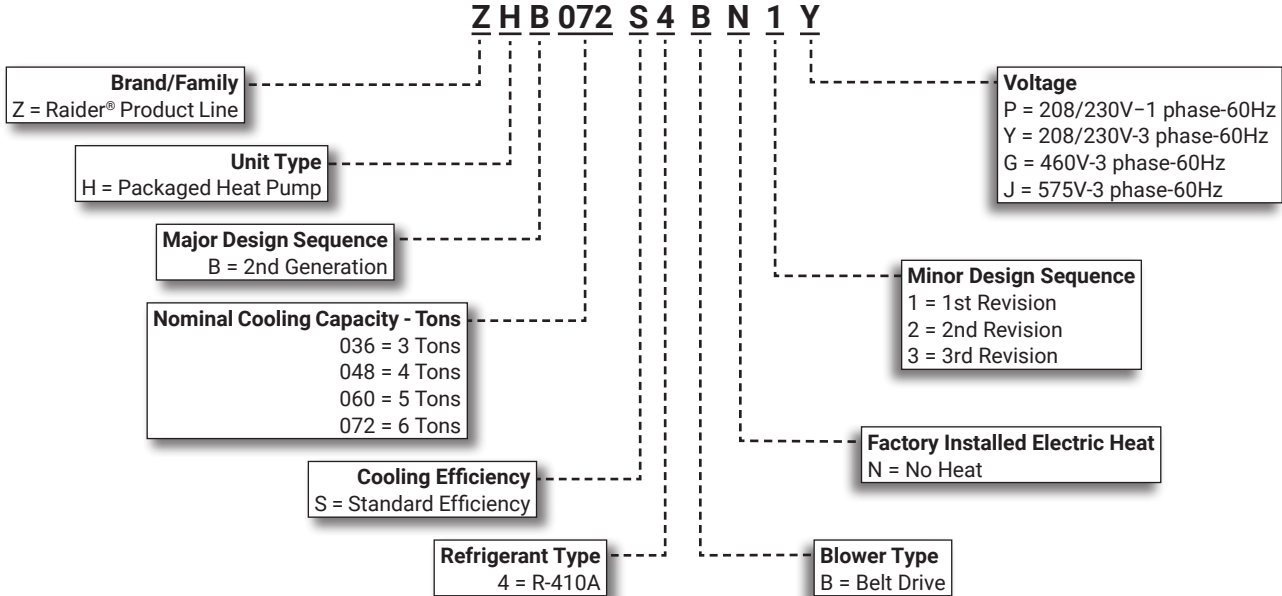

FEATURE HIGHLIGHTS

Raider® rooftop units from Lennox Commercial are the new standard for cost efficient reliable, efficient rooftop units built for long-lasting performance that can significantly improve indoor environments.

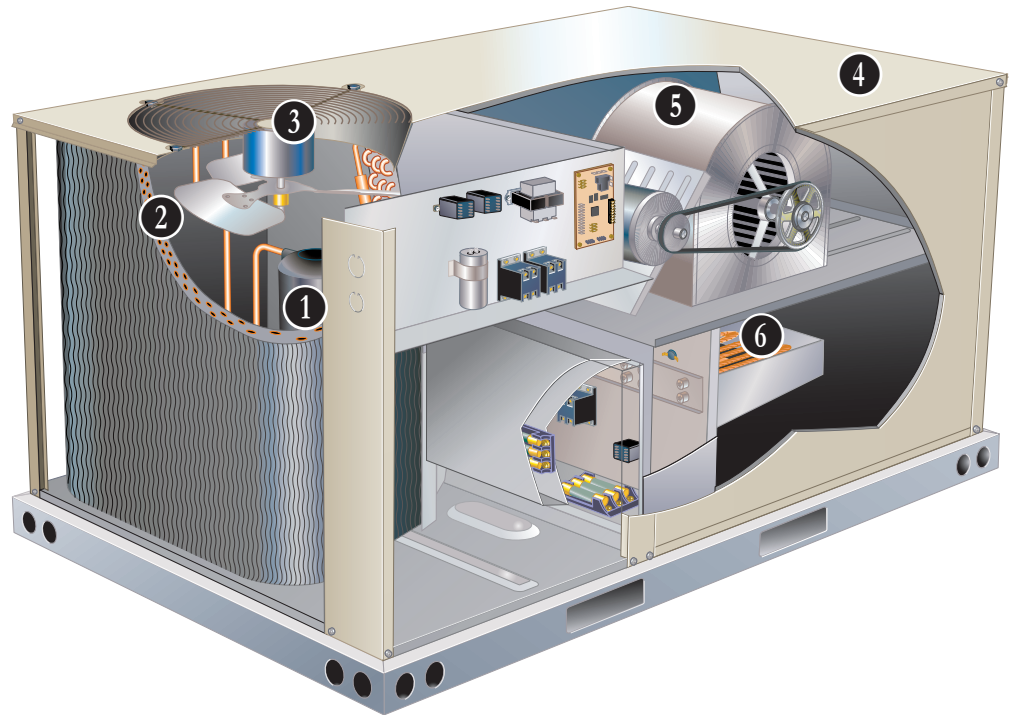

1. Scroll Compressor
2. Lennox' Environ™ Coil System
3. Outdoor Coil Fan Motor
4. Heavy Gauge Steel Cabinet
5. Supply Air Blower
6. Electric Heat (option)

CONTENTS

Approvals And Warranty	3
Cooling / Heating Ratings	12
Dimensions - Accessories	29
Electric Heat Capacities	25
Features And Benefits	3
Model Number Identification.	1
Optional Conventional Temperature Control Systems	8
Options / Accessories	9
Outdoor Sound Data	25
Unit Clearances	26
Weight Data	27

APPROVALS AND WARRANTY

APPROVALS

- AHRI Certified to AHRI Standard 210/240-2008 (3 - 5 ton models)
- AHRI Standard 340/360-2007 (6 ton models)
- CSA certified and listed
- Unit and components are UL, ULC, CEC and National and Canadian Electrical Codes bonded for grounding to meet safety standards for servicing
- All models are ASHRAE 90.1-2010 compliant
- All models meet DOE 2018 energy efficiency standards
- MSAV® equipped models meet California Code of Regulations, Title 24 and ASHRAE 90.1-2010 Section 6.4.3.10 requirements for staged airflow
- ISO 9001 Registered Manufacturing Quality System

WARRANTY

- Compressors - Limited five years
- Lennox' Environ™ Coil System - Limited three years
- High Performance Economizers (optional) - Limited five years
- All other covered components - Limited one year

FEATURES AND BENEFITS

COOLING / HEATING SYSTEM

- Designed to maximize sensible and latent cooling performance at design conditions
- System can operate from 35°F to 125°F without any additional controls

R-410A Refrigerant

- Non-chlorine based
- Ozone friendly

1 Compressor

- Scroll compressors for high performance, reliability and quiet operation
- Resiliently mounted on rubber grommets for quiet operation

Compressor Crankcase Heater

- Protects against refrigerant migration that can occur during low ambient operation

Refrigerant Metering Orifice (All 036 to 060 Models)

- Accurately meters refrigerant in system
- Refrigerant control is accomplished by exact sizing of refrigerant metering orifice

Thermal Expansion Valve (072 Models)

- Assures optimal performance throughout the application range
- Removable element head

Filter/Drier

High capacity filter/drier protects the system from dirt and moisture **High Pressure Switch**

- Protects the compressor from overload conditions such as dirty condenser coils, blocked refrigerant flow, or loss of outdoor fan operation
- Automatic reset

Reversing Valve

- 4-way interchange reversing valve effects a rapid change in direction of refrigerant flow resulting in quick changeover from cooling to heating and vice versa

Defrost Control

- Provides a defrost cycle, if needed, every 30 or 60 or 90 minutes (adjustable) of compressor "on" time at outdoor coil temperature below 35°F
- Temperature switch mounted on outdoor coil liquid line terminates defrost cycle

2 Coil Construction

- Copper tube construction
- Enhanced rippled-edge aluminum fins
- Flared shoulder tubing connections
- Silver soldered construction
- Factory leak tested

Indoor Coil

- Cross row circuiting with rifled tubing optimizes both sensible and latent cooling capacity

Condensate Drain Pan

- Plastic pan, sloped to meet drainage requirements of ASHRAE 62.1
- End drain connection

3 Outdoor Coil Fan Motor

- Thermal overload protected
- Totally enclosed
- Permanently lubricated bearings
- Shaft down (all 036 to 060 models)
- Shaft up (072 models)
- Fan guard mount

Outdoor Coil Fan Guard

- PVC coated fan guard furnished

FEATURES AND BENEFITS

COOLING / HEATING SYSTEM (continued)

Required Selections

Cooling Capacity

- Specify nominal cooling capacity

Options/Accessories

Field Installed

Condensate Drain Trap

- Available in copper or PVC

Drain Pan Overflow Switch

- Monitors condensate level in drain pan
- Shuts down unit if drain becomes clogged

Low Ambient Kit

- Cycles the outdoor fans while allowing compressor operation in the cooling cycle
- Intermittent fan operation allows the system to operate without icing the evaporator coil and losing capacity
- Designed for use in ambient temperatures no lower than 0°F

CABINET

4 Construction

- Heavy-gauge steel panels
- Full perimeter heavy-gauge galvanized steel base rail
- Base rails have rigging holes
- Three sides of the base rail have forklift slots
- Raised edges around duct and power entry openings in the bottom of the unit for water protection

Airflow Choice

- Units are shipped in downflow (vertical) return air flow configuration

NOTE - Units can be field converted to horizontal airflow.

Power Entry

- Electrical lines can be brought through the unit base or through horizontal access knock-outs (end of unit on 036-060 model, side of unit on ZHB072 models)
- ZHB072 models feature three mounting locations for the disconnect:
 - Side mounting on an adjustable panel (removable corner base rail allows access for installation)
 - Side mounting directly over the side power entry knockouts
 - End mounting on an adjustable panel (alternate location)
- See dimension drawing

NOTE - Optional Bottom Power Entry Kit is available.

Exterior Panels

- Constructed of heavy-gauge, galvanized steel
- Two-layer enamel paint finish

Insulation

- All panels adjacent to conditioned air are fully insulated with non-hygroscopic fiberglass insulation

Access Panels

- Compressor
- Heating
- Controls
- Blower
- Air filter/economizer section

Options/Accessories

Factory Installed

Corrosion Protection

- Completely flexible immersed coating
- Electrodeposited dry film process (AST ElectroFin E-Coat)
- Meets Mil Spec MIL-P-53084, ASTM B117 Standard Method Salt Spray Testing
- Indoor Corrosion Protection
 - Coated coil
- Outdoor Corrosion Protection
 - Coated coil

Field Installed

Combination Coil/Hail Guards

- Heavy gauge steel frame
- Painted to match cabinet
- Expanded metal mesh protects outdoor coil

CONTROLS

Unit Control

- All control voltage is provided via a 24V (secondary) transformer with inline fuse protection
- **Heat/Cool Staging** - Capable of up to 2 heat / 2 cool staging with a thermostat
- **Night Setback Mode** - Saves energy by closing outdoor air dampers and operating supply fan on thermostat demand only

Smoke Detectors

NOTE - Smoke detectors are not available and must be field provided by installer.

Options / Accessories

Field Installed

Commercial Control Systems

L Connection® Network

- Complete building automation control system for single or multi-zone applications
- Options include local interface, software for local or remote communication, and hardware for networking other control functions
- See L Connection Network Product Specifications Bulletin for details

FEATURES AND BENEFITS

BLOWER

A wide selection of supply air blower options are available to meet a variety of air flow requirements

5 Motor

- Overload protected
- Ball bearings
- Belt drive motors are offered on all models and are available in several different sizes to maximize air performance

Supply Air Blower

- Forward curved blades
- Blower wheel statically and dynamically balanced.
- Ball bearings
- Adjustable pulley (allows speed change)

Required Selections

Supply Air Blower

- Order blower motor horsepower and drive kit number required when base unit is ordered
- See Drive Kit Specifications Table

ELECTRICAL

Marked & Color-Coded Wiring

- All electrical wiring is color-coded and marked to identify which components it is connecting.

Electrical Plugs

- Positive connection electrical plugs are used to connect common accessories or maintenance parts for easy removal or installation.

Required Selections

Voltage Choice

- Specify when ordering base unit.

Field Installed

Bottom Power Entry Kit

- Kit reduces the number of penetrations in the roof
- Kit includes bulkhead connectors to provides power and control wiring routing through the roof curb

6 Electric Heat

- Helix wound nichrome elements
- Individual element limit controls
- Wiring harness

NOTE - See Options / Accessories tables for ordering information.

NOTE - Unit Fuse Block is required and must be ordered separately. See Electrical / Electric Heat tables for ordering information.

INDOOR AIR QUALITY

Air Filters

- Disposable 2 inch filters furnished as standard

Options/Accessories

Field Installed

Indoor Air Quality (CO₂) Sensor

- Monitors CO₂ levels adjusts economizer dampers as needed for Demand Control Ventilation

OPTIONS / ACCESSORIES

ECONOMIZER

Factory or Field Installed

Economizer (Downflow or Horizontal) (Standard and High Performance Common Features)

- Outdoor Air Hood is furnished
- Includes Barometric Relief Dampers with Exhaust Hood
- Barometric Relief Dampers allow relief of excess air,
- Aluminum blade dampers prevent blow back and outdoor air infiltration during off cycle
- Exhaust hood with bird screen furnished
- Demand Control Ventilation (DCV) ready using optional CO₂ sensors
- Single temperature control is furnished with Economizer
- Outdoor air sensor enables Economizer if the outdoor temperature is less than the setpoint of the control

NOTE - Horizontal Economizer is field installed only.

Standard Economizer Features (Not for Title 24)

- Gear-driven action
- Return air and outdoor air dampers
- Plug-in connections to unit
- Nylon bearings
- Neoprene seals
- 24-volt
- Fully-modulating spring return motor

Standard Economizer Control Module

The Standard Economizer Control Module can be adjusted to operate based on outdoor air temperatures



Economizer Controls:

- **Damper Minimum Position** - Can be set lower than traditional minimum air requirements resulting in cost savings
- **IAQ Sensor** - Signals dampers to modulate and maintain 55°F when CO₂ is higher than the CO₂ setpoint
- **Demand Control Ventilation (DCV) LED** - A steady green Demand Control Ventilation LED indicates the IAQ reading is higher than setpoint and requires more fresh air
- **Free Cool LED** - A steady green LED indicates outdoor air is suitable for free cooling

NOTE - Free Cooling runs when outdoor air temperature is lower than the set temperature on the economizer control.

NOTE: The Free Cooling default setting for outdoor air temperature sensor is 55°F.

High Performance Economizer Features

- Approved for California Title 24 building standards
- Low leakage dampers are Air Movement and Control Association International (AMCA) Class 1A Certified - Maximum 3 CFM per sq. ft. leakage at 1 in. w.g.
- ASHRAE 90.1-2010 compliant
- Gear-driven action
- High torque 24-volt fully-modulating spring return damper motor
- Return air and outdoor air dampers
- Plug-in connections to unit
- Stainless steel bearings
- Enhanced neoprene blade edge seals
- Flexible stainless steel jamb seals minimize air leakage

NOTE - High Performance Economizers are not approved for use with enthalpy controls in Title 24 applications.

NOTE - The Free Cooling setpoint for Title 24 applications must be set based on the Climate Zone where the system is installed. See Section 140.4 "Prescriptive Requirements for Space Conditioning Systems" of the California Energy Commission's 2013 Building Energy Efficiency Standards. Refer to Installation Instructions for complete setup information and menu parameters available.

High Performance Economizer Control Module

- Module provides inputs and outputs to control economizer based on parameter settings
- Module automatically detects sensors by polling to determine which sensors are installed in system
- Module displays any alarm messages (fault detection and diagnostics) as an aid in troubleshooting
- Non-volatile memory retains parameter settings in case of power failure
- Keypad with four navigation buttons and LCD screen is furnished for setting economizer parameters
 - Menu Up/Exit (↑) button returns to the main menu
 - Arrow Up (▲) button moves to the previous or next parameter within the selected menu
 - Arrow Down (▼) button moves to the next parameter within the selected menu
 - Select (enter) (↵) button confirms parameter selection



OPTIONS / ACCESSORIES

ECONOMIZER (continued)

High Performance Economizer Control Module (continued)

Main Menu Structure:

- STATUS (economizer and system operation status)
- SETPOINTS (settings for various setpoint parameters)
- SYSTEM SETUP (settings/information about the system)
- ADVANCED SETUP (freeze protection, CO₂ settings, stage 3 delay, and additional calibration settings)
- CHECKOUT (damper positions)
- ALARMS (output signal that can be configured for remote alarm monitoring)

NOTE - Refer to Installation Instructions for complete setup information and menu parameters available.

Field Installed

Single Enthalpy Temperature Control (Not for Title 24)

- Outdoor air enthalpy sensor enables Economizer if the outdoor enthalpy is less than the setpoint of the control

EXHAUST

Field Installed

Power Exhaust Fan - Downflow or Horizontal

- Installs external to unit for applications with Economizer option
- Provides exhaust air pressure relief
- Interlocked to run when supply air blower is operating
- Fan runs when outdoor air dampers are 50% open (adjustable)
- Motor is overload protected
- Fan is 12 in. diameter
- Five fan blades
- 1/2 hp motor.

OUTDOOR AIR

Field Installed

Outdoor Air Dampers - Downflow

- Single blade damper
- 0 to 25% (fixed) outdoor air adjustable
- Installs in unit
- Automatic model features fully modulating spring return damper motor with plug-in connection
- Manual model features a slide damper

NOTE - Maximum mixed air temperature in cooling mode is 100°F.

ROOF CURBS

Field Installed

Hybrid Roof Curbs, Downflow

- Nail strip furnished; mates to unit
- US National Roofing Contractors approved
- Shipped knocked down
- Interlocking tabs fasten corners together; no tools required
- Can also be fastened together with furnished hardware
- Available in 8, 14, 18, and 24 inch heights

Adaptor Curbs (not shown)

- Curbs are regionally sourced
- Dimensions will vary based upon the source

NOTE - Contact your local sales representative for a detailed cut sheet with applicable dimensions.

CEILING DIFFUSERS

Field Installed

- Flush or Step-Down
- White powder coat finish on diffuser face and grilles
- Insulated UL listed duct liner
- Diffuser box has collars for duct connection
- Step-down diffusers have double deflection blades
- Flush diffusers have fixed blades
- Provisions for suspending
- Internally sealed to prevent recirculation
- Removable return air grille
- Adapts to T-bar ceiling grids or plaster ceilings

Transitions (Supply and Return)

NOTE - Ceiling Diffuser Transitions are not furnished and must be field fabricated.

OPTIONAL CONVENTIONAL TEMPERATURE CONTROL SYSTEMS

ComfortSense® 7500 Commercial 7-Day Programmable Thermostat



- Four-Stage Heating / Two-Stage Cooling
- Universal Multi-Stage
- Intuitive Touchscreen Interface
- Automatic Changeover between Heating and Cooling
- Full Seven-Day Programming
- Four Time Periods Per Day
- Temperature and Humidity Control
- One-Touch Away Mode
- Holiday Scheduling
- Smooth Setback Recovery (SSR)
- Performance Reports
- Notifications/Reminders
- Economizer Relay Control
- Backlit Display
- Wallplate Furnished
- FDD, ASHRAE and IECC Compliant

ComfortSense® 3000 Commercial 5-2 Day Programmable Thermostat

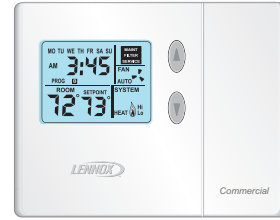

- Two-Stage Heating / Two-Stage Cooling
- Conventional Systems
- Intuitive Interface
- 5-2 Day Programming
- Program Hold
- Remote Indoor Temperature Sensing
- Smooth Setback Recovery (SSR)
- Economizer Relay Control
- Maintenance/Filter/Service Reminders
- Backlit Display
- Wallplate Furnished
- Simple Up and Down Temperature Control

Bacnet Compatible Thermostat With Reheat Function



Description	Model No.	Catalog No.
ComfortSense® 7500 7-Day Programmable	C0STAT06FF2L	17G74
Universal thermostat locking guard (clear)	C0MISC15AE1-	39P21
Temperature Sensors	¹ Remote non-adjustable wall-mount 20k	47W36
	¹ Remote non-adjustable wall-mount 10k	47W37
	Remote non-adjustable discharge air (duct mount)	19L22
	Outdoor temperature sensor	X2658
¹ Remote wall-mount sensors can be applied in any of the following combinations: One Sensor - (1) 47W36, Two Sensors - (2) 47W37, Three Sensors - (2) 47W36 and (1) 47W37 Four Sensors - (4) 47W36, Five Sensors - (3) 47W36 and (2) 47W37		
ComfortSense® 3000 5-2 Day Programmable	C0STAT05FF1L	11Y05
Thermostat wall mounting plate	C0MISC17AE1-	X2659
Temperature Sensor	Remote non-adjustable wall mount 10k averaging	47W37
BACnet Controls	7-Day BACnet Thermostat	Y8241
	BACnet Module (factory or field)	K0CTRL31B-2
² BACnet Room Sensors	With Display	K0SNSR01FF1
	Without Display	K0SNSR00FF1
BACnet Accessories	Plenum Cable (RJ45/CAT5 75 ft.)	K0MISC00FF1

² Only compatible with BACnet Module (16X71).

- 7-Day Programmable
- BTL listed MS/TP ensures compatibility with any BACnet system
- Built-in control programs for conventional and heat pump applications
- Conventional systems up to 3-stage heat and 3-stage cool
- Heat pumps with 1 or 2 compressors and up to 2-stage auxiliary heat
- On-board temperature and humidity sensor
- Multiple configurable inputs and outputs enable advanced control strategies
- Set-up Wizard enables rapid system configuration
- No special tools required for installation or commissioning
- Seven-day (2, 4 or 6 event) occupancy scheduling per day
- Backlit 5-inch LCD touchscreen

OPTIONS / ACCESSORIES

Item	Catalog No.	ZHB 036	ZHB 048	ZHB 060	ZHB 072
COOLING SYSTEM					
Condensate Drain Trap	PVC - C1TRAP20AD2 Copper - C1TRAP10AD2	76W26 76W27	X X	X X	X X
Drain Pan Overflow Switch	Z1SNSR90A1	99W59	X	X	X
Low Ambient Kit	Z1SNSR34A-1	99W68	X	X	X
BLOWER - SUPPLY AIR					
Motors	Belt Drive - 0.75 hp (208/230V-1ph) Standard Efficiency	Factory	³ O	³ O	³ O
	Belt Drive - 1 hp (208/230V, 460V, 575V-3ph) Standard Efficiency	Factory	O	O	O
	Belt Drive - 1.5 hp (208/230V-1ph or 3 ph, 460V, 575V-3ph) Standard Efficiency	Factory	O	O	O
	Belt Drive-2 hp (208/230V, 460V, 575V-3ph) Standard Efficiency	Factory			O
Drive Kits	Kit #ZA01 - 678-1035 rpm	Factory	O		
See Blower Data Tables for selection	Kit #ZA02 - 803-1226 rpm	Factory		O	
	Kit #ZA03 - 906-1383 rpm	Factory			O
	Kit #ZA04 - 964-1471 rpm	Factory	O		
	¹ Kit #ZA05 - 1098-1490 rpm	Factory		O	
	¹ Kit #ZA06 - 1262-1634 rpm	Factory			
	Kit #ZAA01 - 522-784 rpm	Factory			³ O
	Kit #ZAA02 - 632-875 rpm	Factory		³ O	O
	¹ Kit #ZAA03 - 798-1105 rpm	Factory		³ O	O
	Kit #ZAA04 - 921-1228 rpm	Factory			² O
ELECTRICAL					
Voltage	208/230V - 1 phase	Factory	³ O	³ O	³ O
60 Hz	208/230V - 3 phase	Factory	O	O	O
	460V - 3 phase	Factory	O	O	O
	575V - 3 phase	Factory	O	O	O
Bottom Power Entry Kit	Z1PEKT01A-1	98W08	X	X	X
ELECTRIC HEAT					
5 kW	208/230V-1ph - Z1EH0050AN1P	98W96	X	X	X
	208/230V-3ph - Z1EH0050AN1Y	99W01	X	X	X
	460V-3ph - Z1EH0050AN1G	99W06	X	X	X
	575V-3ph - Z1EH0050AN1J	99W11	X	X	X
7.5 kW	208/230V-1ph - Z1EH0075AN1P	98W97	X	X	X
	208/230V-3ph - Z1EH0075AN1Y	99W02	X	X	X
	460V-3ph - Z1EH0075AN1G	99W07	X	X	X
	575V-3ph - Z1EH0075AN1J	99W12	X	X	X
10 kW	208/230V-1ph - Z1EH0100AN1P	98W98	X	X	X
	208/230V-3ph - Z1EH0100AN1Y	99W03	X	X	X
	460V-3ph - Z1EH0100AN1G	99W08	X	X	X
	575V-3ph - Z1EH0100AN1J	99W13	X	X	X
15 kW	208/230V-1ph - Z1EH0150AN1P	98W99	X	X	X
	208/230V-3ph - Z1EH0150AN1Y	99W04	X	X	X
	460V-3ph - Z1EH0150AN1G	99W09	X	X	X
	575V-3ph - Z1EH0150AN1J	99W14	X	X	X
22.5 kW	208/230V-1ph - Z1EH0225AN1P	99W00		X	X
	208/230V-3ph - Z1EH0225AN1Y	99W05		X	X
	460V-3ph - Z1EH0225AN1G	99W10		X	X
	575V-3ph - Z1EH0225AN1J	99W15		X	X
30 kW	208/230V-3ph - Z1EH0300AN1Y	13U01			X
	460V-3PH - Z1EH0300AN1G	13U02			X
	575V-3PH - Z1EH0300AN1J	13U03			X
ELECTRIC HEAT ACCESSORIES					
Unit Fuse Block (required) - See Electrical/Electric Heat Tables for Selection			X	X	X

¹ 1.5 hp blower motor is the minimum required with the ZA05, ZA06 and ZAA03 drive kits.

² 2 hp blower motor is required with the ZAA04 drive kit.

³ ZHB models only.

NOTE - The catalog and model numbers that appear here are for ordering field installed accessories only.

OX - Field Installed or Configure to Order (Factory Installed)

O - Configure to Order (Factory Installed)

X - Field Installed.

OPTIONS / ACCESSORIES

Item	Catalog No.	ZHB 036	ZHB 048	ZHB 060	ZHB 072
CABINET					
Coil/Hail Guards	Z1GARD20AT1	12X20	X	X	X
	Z1GARD20AL1	16A41			X
Corrosion Protection	Factory	O	O	O	O
ECONOMIZER					
Standard Economizer With Outdoor Air Hood (Not for Title 24)					
Standard Economizer (Downflow) Includes Barometric Relief Dampers and Exhaust Hood	Z1ECON30A-2	14D94	OX	OX	OX
Standard Economizer (Horizontal) Includes Barometric Relief Dampers and Exhaust Hood	Z1ECON16A-2	14D92	X	X	X
Standard Economizer Controls (Not for Title 24)					
Single Enthalpy Control	C1SNSR64FF1	53W64	X	X	X
High Performance Economizer With Outdoor Air Hood (Approved for California Title 24 Building Standards / AMCA Class 1A Certified)					
High Performance Economizer (Downflow) Includes Barometric Relief Dampers and Exhaust Hood	Z1ECON32A-2	14D95	OX	OX	OX
High Performance Economizer (Horizontal) Includes Barometric Relief Dampers and Exhaust Hood	Z1ECON33A-2	14D93	X	X	X
High Performance Economizer Controls (Not for Title 24)					
Single Enthalpy Control	C1SNSR61FF1	11G21	X	X	X
OUTDOOR AIR					
Outdoor Air Dampers - Includes Outdoor Air Hood					
Motorized	Z1DAMP21A-2	15D19	X	X	X
Manual	Z1DAMP11A-2	15D20	X	X	X
POWER EXHAUST FAN					
Standard Static (Downflow)	208/230V-1 or 3ph - Z1PWRE10A-1P	21E01	X	X	X
	460V-3ph - Z1PWRE10A-1G	23E01	X	X	X
Standard Static (Horizontal)	208/230V-1 or 3ph - Z1PWRE15A-1P	24E01	X	X	X
	460V-3ph - Z1PWRE15A-1G	28E01	X	X	X
575V Transformer Kit	575V-3ph - Z1TRFM20A-1J	59E02	X	X	X
NOTE - Order 575V Transformer Kit with 208/230V Power Exhaust Fan for 575V applications.					
INDOOR AIR QUALITY					
Indoor Air Quality (CO₂) Sensors					
Sensor - Wall-mount, off-white plastic cover with LCD display	C0SNSR50AE1L	77N39	X	X	X
Sensor - Wall-mount, black plastic case, no display, rated for plenum mounting	C0SNSR53AE1L	87N54	X	X	X
CO ₂ Sensor Duct Mounting Kit - for downflow applications	C0MISC19AE1	85L43	X	X	X
Aspiration Box - for duct mounting non-plenum rated CO ₂ sensor (77N39)	C0MISC16AE1	90N43	X	X	X
ROOF CURBS					
Hybrid Roof Curbs, Downflow					
8 in. height	Z1CURB70A-1	11F76	X	X	X
14 in. height	Z1CURB71A-1	11F77	X	X	X
18 in. height	Z1CURB72A-1	11F78	X	X	X
24 in. height	Z1CURB73A-1	11F79	X	X	X
CEILING DIFFUSERS					
Step-Down - Order one	RTD9-65S	13K60	X	X	X
	RTD11-95S	13K61			X
Flush - Order one	FD9-65S	13K55	X	X	X
	FD11-95S	13K56			X

NOTE - Ceiling Diffuser Transitions are not furnished and must be field fabricated.

NOTE - The catalog and model numbers that appear here are for ordering field installed accessories only.

OX - Field Installed or Configure to Order (Factory Installed)

O - Configure to Order (Factory Installed)

X - Field Installed.

SPECIFICATIONS

General Data		Nominal Tonnage	3 Ton	4 Ton	5 Ton	6 Ton
		Model No.	ZHB036S4B	ZHB048S4B	ZHB060S4B	ZHB072S4B
		Efficiency Type	Standard	Standard	Standard	Standard
Cooling Performance	Gross Cooling Capacity - Btuh		36,300	47,900	59,700	71,000
	Net Cooling Capacity - Btuh		¹ 35,000	¹ 46,500	¹ 58,000	² 69,000
	AHRI Rated Air Flow - cfm		1260	1520	2015	1860
	³ Sound Rating Number (SRN) (dBA) Cooling		79	78	82	86
	Total Unit Power - kW		3.1	4.2	5.2	6.4
	SEER (Btuh/Watt)		¹ 14.00	¹ 14.00	¹ 14.00	---
	IEER (Btuh/Watt)		---	---	---	² 12.20
	EER (Btuh/Watt)		¹ 11.40	¹ 11.20	¹ 11.20	² 11.00
Heating Performance	Total High Heating Capacity - Btuh		34,200	45,000	55,000	70,000
	Total Unit Power - kW		2.9	3.8	4.5	6.3
	¹ COP		3.50	3.50	3.60	3.30
	HSPF - Region IV (Region V)		8.00 (6.70)	8.00 (6.70)	8.00 (6.70)	---
	Total Low Heating Capacity - Btuh		20,000	26,100	32,500	40,000
	Total Unit Power - kW		2.7	3.5	4.2	5.4
	COP		2.20	2.20	2.25	2.25
Refrigerant	Type		R-410A	R-410A	R-410A	R-410A
	Charge Furnished		14 lbs. 8 oz.	16 lbs. 5 oz.	14 lbs. 4 oz.	18 lbs. 0 oz.
Electric Heat Available - See page 9			5, 7.5, 10, 15 kW	5, 7.5, 10, 15, 22.5 kW	7.5, 10, 15, 22.5, 30 kW	
Compressor Type (one per unit)			Scroll	Scroll	Scroll	Scroll
Outdoor Coil	Net face area - sq. ft.		19.9	19.9	19.9	25.0
	Tube diameter - in.		3/8	3/8	3/8	3/8
	Number of rows		2	2	2	2
	Fins / inch		20	20	20	20
	Expansion device type		Balanced port TXV, removable head			
Outdoor Coil Fan	Motor HP		(1) 1/4	(1) 1/4	(1) 1/3	(1) 1/3
	Motor rpm		825	825	1075	1050
	Total motor watts		300	300	350	350
	Diameter - in.		(1) 22	(1) 22	(1) 22	(1) 24
	Number of blades		4	4	3	3
	Total air volume - cfm		3335	3335	3600	4350
Indoor Coil	Net face area - sq. ft.		9.6	10.8	10.8	10.8
	Tube diameter - in.		3/8	3/8	3/8	3/8
	Number of rows		3	3	3	3
	Fins per inch		14	14	14	14
	Drain Connection (no. and size) - in.		(1) 1 NPT	(1) 1 NPT	(1) 1 NPT	(1) 1 NPT
	Expansion device type		Fixed Orifice	Fixed Orifice	Fixed Orifice	Balanced port TXV, removable power head
⁴ Indoor Blower & Drive Selection	Nominal Motor HP		⁵ 0.75 hp, ⁶ 1 hp, 1.5 hp	⁵ 0.75 hp, ⁶ 1 hp, 1.5 hp	⁵ 0.75 hp, ⁶ 1 hp, 1.5 hp	1 hp, 1.5 hp, 2 hp
	Maximum Usable Motor HP		0.86 hp, 1.15 hp, 1.7 hp	0.86 hp, 1.15 hp, 1.7 hp	0.86 hp, 1.15 hp, 1.7 hp	1.15 hp, 1.7 hp, 2.3 hp
	Available Drive Kits		Kit #ZAA01 678-1035 rpm	Kit #ZAA02 803-1226 rpm	Kit #ZAA01 522-784 rpm	Kit #ZAA02 632-875 rpm
			Kit #ZAA04 964-1471 rpm	⁷ Kit #ZAA05 1098-1490 rpm	Kit #ZAA02 632-875 rpm	⁷ Kit #ZAA03 798-1105 rpm
		Wheel nominal diameter x width - in.		10 x 10	10 x 10	15 x 9
Filters	Type		Disposable			
	Number and size - in.		(4) 16 x 20 x 2	(2) 16 x 20 x 2 (2) 20 x 20 x 2	(2) 16 X 20 X 2 (2) 20 X 20 X 2	(2) 20 x 20 x 2 (2) 16 x 20 x 2
Electrical Characteristics - 60 Hz			208/230V 1 phase 208/230V, 460V & 575V 3 phase	208/230V, 1 phase 208/230V 460V & 575V 3 phase	208/230V, 1 phase 208/230V 460V & 575V 3 phase	208/230V 460V & 575V 3 Phase

NOTE - Net capacity includes evaporator blower motor heat deduction. Gross capacity does not include evaporator blower motor heat deduction.

^{1,2} AHRI Certified to AHRI Standard ¹210/240 or ²340/360:

Cooling Ratings - 95°F outdoor air temperature and 80°F db/67°F wb entering indoor coil air.

High Temperature Heating Ratings - 47°F db/43°F wb outdoor air temperature and 70°F entering indoor coil air.

Low Temperature Heating Ratings - 17°F db/15°F wb outdoor air temperature and 70°F entering indoor coil air.

³ Sound Rating Number (SRN) rated in accordance with test conditions included in ANSI/AHRI Standard 270-2008.

⁴ Using total air volume and system static pressure requirements determine from blower performance tables rpm and motor hp required. Maximum usable hp of motors furnished are shown. In Canada, nominal motor hp is also maximum usable motor hp output. If motors of comparable hp are used, be sure to keep within the service factor limitations outlined on the motor nameplate.

⁵ 0.75 hp motor is only available for 208/230V-1ph applications.

⁶ 1 hp blower motor is not available for 208/230V-1ph applications.

⁷ 1.5 hp motor is the minimum required with ZAA05 and ZAA03 drive kits.

⁸ 2.0 hp motor is required with ZAA04 drive kits.

COOLING / HEATING RATINGS

NOTE – For Temperatures and Capacities not shown in tables, see bulletin – Cooling Unit Rating Table Correction Factor Data in Miscellaneous Engineering Data section.

3 TON COOLING STANDARD EFFICIENCY ZHB036S4

Entering Wet Bulb Temperature	Total Air Volume	Outdoor Air Temperature Entering Outdoor Coil																			
		85°F					95°F					105°F					115°F				
		Total Cool Cap.	Comp. Motor Input	Sensible To Total Ratio (S/T)			Total Cool Cap.	Comp. Motor Input	Sensible To Total Ratio (S/T)			Total Cool Cap.	Comp. Motor Input	Sensible To Total Ratio (S/T)			Total Cool Cap.	Comp. Motor Input	Sensible To Total Ratio (S/T)		
				Dry Bulb					Dry Bulb					Dry Bulb					Dry Bulb		
cfm	kBtuh	kW	75°F	80°F	85°F	kBtuh	kW	75°F	80°F	85°F	kBtuh	kW	75°F	80°F	85°F	kBtuh	kW	75°F	80°F	85°F	
63°F	960	34.7	2.11	0.7	0.85	1	31.7	2.38	0.7	0.88	1	28.6	2.7	0.72	0.92	1	25.4	3.08	0.74	0.96	1
	1200	36.9	2.12	0.76	0.95	1	33.8	2.39	0.78	0.98	1	30.7	2.71	0.8	1	1	27.7	3.09	0.84	1	1
	1440	38.9	2.13	0.83	1	1	36	2.4	0.85	1	1	33	2.73	0.89	1	1	29.7	3.09	0.93	1	1
67°F	960	37.3	2.12	0.54	0.68	0.82	34.3	2.4	0.53	0.68	0.84	31.1	2.71	0.53	0.7	0.87	27.7	3.08	0.53	0.72	0.92
	1200	39.6	2.13	0.58	0.74	0.91	36.3	2.4	0.58	0.76	0.94	32.9	2.73	0.58	0.78	0.98	29.4	3.09	0.59	0.81	1
	1440	41.2	2.14	0.61	0.8	0.99	37.8	2.41	0.62	0.83	1	34.3	2.73	0.63	0.86	1	30.5	3.09	0.64	0.91	1
71°F	960	40	2.13	0.39	0.53	0.66	36.8	2.41	0.38	0.52	0.66	33.6	2.72	0.37	0.52	0.68	30	3.09	0.35	0.52	0.7
	1200	42.4	2.15	0.41	0.57	0.72	39	2.42	0.4	0.57	0.73	35.5	2.73	0.39	0.58	0.75	31.8	3.1	0.38	0.58	0.79
	1440	44	2.16	0.43	0.61	0.78	40.5	2.43	0.42	0.62	0.81	36.9	2.74	0.42	0.62	0.84	33	3.11	0.41	0.64	0.88

3 TON HEATING STANDARD EFFICIENCY ZHB036S4

Indoor Coil Air Volume 70°F Dry Bulb cfm	Air Temperature Entering Outdoor Coil									
	65°F		45°F		25°F		5°F		-15°F	
	Total Heating Capacity	Comp. Motor Input	Total Heating Capacity	Comp. Motor Input	Total Heating Capacity	Comp. Motor Input	Total Heating Capacity	Comp. Motor Input	Total Heating Capacity	Comp. Motor Input
	kBtuh	kW	kBtuh	kW	kBtuh	kW	kBtuh	kW	kBtuh	kW
960	41.2	2.49	32	2.38	22.6	2.27	15.1	2.07	7.5	1.54
1200	41.9	2.32	32.7	2.22	23.3	2.11	15.9	1.91	8.2	1.38
1440	42.5	2.23	33.3	2.13	23.8	2.02	16.4	1.82	8.7	1.29

4 TON COOLING STANDARD EFFICIENCY ZHB048S4

Entering Wet Bulb Temperature	Total Air Volume	Outdoor Air Temperature Entering Outdoor Coil																			
		85°F					95°F					105°F					115°F				
		Total Cool Cap.	Comp. Motor Input	Sensible To Total Ratio (S/T)			Total Cool Cap.	Comp. Motor Input	Sensible To Total Ratio (S/T)			Total Cool Cap.	Comp. Motor Input	Sensible To Total Ratio (S/T)			Total Cool Cap.	Comp. Motor Input	Sensible To Total Ratio (S/T)		
				Dry Bulb					Dry Bulb					Dry Bulb					Dry Bulb		
cfm	kBtuh	kW	75°F	80°F	85°F	kBtuh	kW	75°F	80°F	85°F	kBtuh	kW	75°F	80°F	85°F	kBtuh	kW	75°F	80°F	85°F	
63°F	1280	45.5	2.92	0.69	0.85	1	41.9	3.32	0.7	0.87	1	38.2	3.78	0.71	0.9	1	34.1	4.32	0.73	0.95	1
	1600	48.4	2.93	0.75	0.94	1	44.7	3.32	0.77	0.97	1	40.9	3.78	0.79	1	1	37	4.32	0.82	1	1
	1920	50.9	2.93	0.81	1	1	47.4	3.35	0.84	1	1	43.7	3.81	0.87	1	1	39.7	4.32	0.91	1	1
67°F	1280	49	2.93	0.53	0.67	0.81	45.3	3.33	0.53	0.68	0.83	41.3	3.78	0.52	0.69	0.86	37.1	4.33	0.53	0.71	0.9
	1600	51.7	2.93	0.57	0.73	0.9	47.8	3.35	0.57	0.74	0.93	43.7	3.79	0.57	0.76	0.97	39.2	4.33	0.58	0.79	1
	1920	53.8	2.94	0.6	0.79	0.98	49.7	3.35	0.61	0.81	1	45.4	3.8	0.62	0.84	1	40.8	4.33	0.63	0.88	1
71°F	1280	52.3	2.93	0.39	0.52	0.65	48.5	3.35	0.38	0.52	0.66	44.5	3.8	0.37	0.52	0.67	40.1	4.35	0.35	0.52	0.69
	1600	55.3	2.94	0.41	0.56	0.71	51.3	3.35	0.4	0.56	0.72	47	3.82	0.39	0.57	0.74	42.3	4.35	0.38	0.58	0.77
	1920	57.4	2.95	0.43	0.6	0.77	53.1	3.37	0.42	0.6	0.79	48.8	3.84	0.41	0.62	0.82	43.8	4.35	0.41	0.63	0.86

4 TON HEATING STANDARD EFFICIENCY ZHB048S4

Indoor Coil Air Volume 70°F Dry Bulb cfm	Air Temperature Entering Outdoor Coil									
	65°F		45°F		25°F		5°F		-15°F	
	Total Heating Capacity	Comp. Motor Input	Total Heating Capacity	Comp. Motor Input	Total Heating Capacity	Comp. Motor Input	Total Heating Capacity	Comp. Motor Input	Total Heating Capacity	Comp. Motor Input
	kBtuh	kW	kBtuh	kW	kBtuh	kW	kBtuh	kW	kBtuh	kW
1280	50.8	3.58	43.4	3.18	36.2	2.77	25.6	2.42	12.2	1.85
1600	51.8	3.35	44.3	2.95	37.1	2.55	26.5	2.19	13.1	1.62
1920	52.5	3.21	45	2.82	37.9	2.41	27.3	2.06	13.9	1.48

COOLING / HEATING RATINGS

NOTE – For Temperatures and Capacities not shown in tables, see bulletin – Cooling Unit Rating Table Correction Factor Data in Miscellaneous Engineering Data section.

5 TON COOLING STANDARD EFFICIENCY ZHB060S4

Entering Wet Bulb Temperature	Total Air Volume	Outdoor Air Temperature Entering Outdoor Coil																			
		85°F					95°F					105°F					115°F				
		Total Cool Cap.	Comp. Motor Input	Sensible To Total Ratio (S/T)			Total Cool Cap.	Comp. Motor Input	Sensible To Total Ratio (S/T)			Total Cool Cap.	Comp. Motor Input	Sensible To Total Ratio (S/T)			Total Cool Cap.	Comp. Motor Input	Sensible To Total Ratio (S/T)		
				Dry Bulb					Dry Bulb					Dry Bulb					Dry Bulb		
cfm	kBtuh	kW	75°F	80°F	85°F	kBtuh	kW	75°F	80°F	85°F	kBtuh	kW	75°F	80°F	85°F	kBtuh	kW	75°F	80°F	85°F	
63°F	1600	56.7	3.61	0.68	0.86	1	50.2	4.08	0.68	0.87	1	43.5	4.65	0.68	0.9	1	36.6	5.32	0.68	0.94	1
	2000	61.2	3.63	0.75	0.95	1	54.6	4.11	0.76	0.98	1	47.7	4.68	0.78	1	1	41.2	5.36	0.8	1	1
	2400	65.3	3.66	0.82	1	1	58.9	4.14	0.84	1	1	52.4	4.7	0.86	1	1	45.4	5.38	0.9	1	1
67°F	1600	62.3	3.64	0.51	0.67	0.82	55.6	4.12	0.49	0.66	0.84	48.7	4.69	0.46	0.66	0.86	41.3	5.34	0.43	0.67	0.9
	2000	66.8	3.66	0.56	0.74	0.91	59.7	4.14	0.54	0.74	0.94	52.4	4.71	0.53	0.76	0.97	44.7	5.38	0.51	0.78	1
	2400	69.9	3.68	0.6	0.8	0.99	62.7	4.16	0.59	0.82	1	55.1	4.72	0.59	0.84	1	47.1	5.39	0.58	0.88	1
71°F	1600	67.9	3.66	0.36	0.51	0.65	61.2	4.15	0.33	0.49	0.65	53.9	4.71	0.28	0.47	0.65	46.5	5.4	0.24	0.45	0.65
	2000	72.6	3.69	0.39	0.56	0.72	65.4	4.18	0.36	0.55	0.73	57.8	4.74	0.33	0.54	0.74	49.8	5.41	0.28	0.52	0.76
	2400	75.9	3.71	0.41	0.6	0.78	68.4	4.19	0.39	0.6	0.8	60.5	4.76	0.36	0.59	0.82	52.2	5.44	0.32	0.6	0.86

5 TON HEATING STANDARD EFFICIENCY ZHB060S4

Indoor Coil Air Volume 70°F Dry Bulb cfm	Air Temperature Entering Outdoor Coil									
	65°F		45°F		25°F		5°F		-15°F	
	Total Heating Capacity	Comp. Motor Input	Total Heating Capacity	Comp. Motor Input	Total Heating Capacity	Comp. Motor Input	Total Heating Capacity	Comp. Motor Input	Total Heating Capacity	Comp. Motor Input
	kBtuh	kW	kBtuh	kW	kBtuh	kW	kBtuh	kW	kBtuh	kW
1600	61.7	3.84	52.8	3.65	44.4	3.46	31.7	3.14	15.1	2.34
2000	62.7	3.59	53.9	3.4	45.5	3.21	32.8	2.9	16.2	2.1
2400	63.7	3.45	54.8	3.26	46.4	3.07	33.7	2.75	17.1	1.95

6 TON COOLING STANDARD EFFICIENCY ZHB072S4

Entering Wet Bulb Temperature	Total Air Volume	Outdoor Air Temperature Entering Outdoor Coil																			
		85°F					95°F					105°F					115°F				
		Total Cool Cap.	Comp. Motor Input	Sensible To Total Ratio (S/T)			Total Cool Cap.	Comp. Motor Input	Sensible To Total Ratio (S/T)			Total Cool Cap.	Comp. Motor Input	Sensible To Total Ratio (S/T)			Total Cool Cap.	Comp. Motor Input	Sensible To Total Ratio (S/T)		
				Dry Bulb					Dry Bulb					Dry Bulb					Dry Bulb		
cfm	kBtuh	kW	75°F	80°F	85°F	kBtuh	kW	75°F	80°F	85°F	kBtuh	kW	75°F	80°F	85°F	kBtuh	kW	75°F	80°F	85°F	
63°F	1800	69.3	4.91	0.71	0.84	0.97	64.8	5.48	0.71	0.86	0.99	60	6.1	0.73	0.88	1	54.9	6.83	0.75	0.91	1
	2300	73.6	4.96	0.76	0.92	1	68.8	5.52	0.78	0.94	1	63.8	6.14	0.8	0.97	1	58.5	6.85	0.82	1	1
	2800	76.9	4.98	0.82	0.99	1	72.1	5.55	0.84	1	1	67.2	6.18	0.86	1	1	62	6.87	0.89	1	1
67°F	1800	73.8	4.96	0.56	0.68	0.81	69.1	5.52	0.56	0.69	0.83	64.2	6.14	0.56	0.71	0.85	58.7	6.85	0.56	0.72	0.88
	2300	78.1	4.99	0.59	0.74	0.89	73.1	5.56	0.6	0.76	0.91	67.6	6.17	0.6	0.78	0.94	62	6.86	0.61	0.8	0.98
	2800	81	5.01	0.62	0.8	0.96	75.7	5.57	0.63	0.82	0.98	70.2	6.19	0.64	0.84	1	64.4	6.89	0.66	0.87	1
71°F	1800	78.2	4.99	0.42	0.54	0.66	73.4	5.56	0.41	0.55	0.67	68.1	6.18	0.41	0.55	0.68	62.7	6.87	0.4	0.55	0.7
	2300	82.6	5.02	0.44	0.58	0.72	77.6	5.59	0.43	0.59	0.74	72	6.22	0.43	0.6	0.76	66.1	6.9	0.43	0.61	0.78
	2800	85.7	5.05	0.45	0.62	0.78	80.3	5.61	0.45	0.63	0.8	74.5	6.23	0.45	0.64	0.82	68.3	6.91	0.45	0.66	0.85

6 TON HEATING STANDARD EFFICIENCY ZHB072S4

Indoor Coil Air Volume 70°F Dry Bulb cfm	Air Temperature Entering Outdoor Coil									
	65°F		45°F		25°F		5°F		-15°F	
	Total Heating Capacity	Comp. Motor Input	Total Heating Capacity	Comp. Motor Input	Total Heating Capacity	Comp. Motor Input	Total Heating Capacity	Comp. Motor Input	Total Heating Capacity	Comp. Motor Input
	kBtuh	kW	kBtuh	kW	kBtuh	kW	kBtuh	kW	kBtuh	kW
1800	89.1	5.92	68.6	5.47	48.1	5.01	29.3	4.43	14.7	3.33
2300	90.5	5.56	70.1	5.1	49.5	4.64	30.8	4.06	16.1	2.97
2800	91.5	5.35	71	4.89	50.5	4.43	31.7	3.85	17.1	2.76

BLOWER TABLE INCLUDES RESISTANCE FOR BASE UNIT ONLY WITH DRY INDOOR COIL AND AIR FILTERS IN PLACE.

FOR ALL UNITS ADD:

1 - Any factory installed options air resistance (heat section, economizer, wet coil, etc.).

2 - Any field installed accessories air resistance (duct resistance, diffuser, etc.).

See page 19 for blower motors and drives and wet coil and options/accessory air resistance data.

DOWNFLOW

Air Volume cfm	External Static - in. w.g.															
	0.10		0.20		0.30		0.40		0.50		0.60		0.70		0.80	
	RPM	BHP	RPM	BHP	RPM	BHP	RPM	BHP	RPM	BHP	RPM	BHP	RPM	BHP	RPM	BHP
900	562	0.11	621	0.13	685	0.16	752	0.18	818	0.21	883	0.24	944	0.27	1001	0.30
1000	584	0.13	644	0.16	707	0.18	773	0.21	838	0.24	901	0.27	960	0.3	1015	0.33
1100	609	0.16	669	0.18	732	0.21	796	0.24	860	0.27	921	0.30	978	0.34	1031	0.37
1200	635	0.19	696	0.21	758	0.24	821	0.27	883	0.31	942	0.34	997	0.38	1049	0.42
1300	664	0.22	725	0.25	786	0.28	848	0.31	908	0.35	965	0.39	1018	0.43	1068	0.47
1400	696	0.26	756	0.29	816	0.32	876	0.36	935	0.40	989	0.44	1041	0.48	1089	0.52
1500	729	0.30	788	0.33	848	0.37	906	0.41	962	0.45	1015	0.50	1065	0.54	1112	0.58

Air Volume cfm	External Static - in. w.g.															
	0.90		1.00		1.10		1.20		1.30		1.40		1.50		1.60	
	RPM	BHP	RPM	BHP	RPM	BHP	RPM	BHP	RPM	BHP	RPM	BHP	RPM	BHP	RPM	BHP
900	1053	0.32	1103	0.35	1149	0.38	1193	0.41	1234	0.43	1274	0.47	1312	0.50	1351	0.53
1000	1066	0.36	1114	0.39	1160	0.42	1204	0.45	1245	0.48	1284	0.51	1322	0.54	1361	0.58
1100	1081	0.40	1128	0.43	1173	0.46	1216	0.49	1257	0.53	1296	0.56	1334	0.60	1372	0.63
1200	1097	0.45	1144	0.48	1188	0.51	1231	0.54	1271	0.58	1310	0.62	1347	0.66	1385	0.69
1300	1115	0.50	1161	0.53	1204	0.56	1246	0.60	1286	0.64	1325	0.68	1362	0.72	1399	0.76
1400	1135	0.56	1179	0.59	1222	0.62	1264	0.66	1303	0.70	1341	0.75	1378	0.79	1415	0.83
1500	1157	0.62	1200	0.65	1242	0.69	1282	0.73	1321	0.77	1359	0.82	1396	0.86	1431	0.91

HORIZONTAL

Air Volume cfm	External Static - in. w.g.															
	0.10		0.20		0.30		0.40		0.50		0.60		0.70		0.80	
	RPM	BHP	RPM	BHP	RPM	BHP	RPM	BHP	RPM	BHP	RPM	BHP	RPM	BHP	RPM	BHP
900	560	0.16	624	0.18	692	0.20	761	0.21	830	0.23	896	0.25	956	0.27	1012	0.29
1000	583	0.18	647	0.20	715	0.22	783	0.24	850	0.25	914	0.27	972	0.30	1025	0.33
1100	609	0.20	673	0.22	740	0.24	808	0.26	873	0.28	934	0.31	990	0.34	1041	0.37
1200	637	0.23	702	0.25	769	0.27	835	0.29	898	0.32	956	0.35	1009	0.38	1058	0.41
1300	669	0.26	734	0.28	800	0.30	863	0.33	924	0.36	979	0.39	1030	0.43	1077	0.46
1400	704	0.29	768	0.32	832	0.35	894	0.37	951	0.41	1004	0.44	1052	0.48	1097	0.52
1500	742	0.33	805	0.36	867	0.39	925	0.42	980	0.46	1030	0.50	1076	0.54	1119	0.58

Air Volume cfm	External Static - in. w.g.															
	0.90		1.00		1.10		1.20		1.30		1.40		1.50		1.60	
	RPM	BHP	RPM	BHP	RPM	BHP	RPM	BHP	RPM	BHP	RPM	BHP	RPM	BHP	RPM	BHP
900	1064	0.32	1114	0.35	1162	0.38	1208	0.41	1251	0.45	1293	0.49	1333	0.52	1373	0.56
1000	1076	0.36	1124	0.39	1170	0.42	1216	0.46	1259	0.49	1300	0.53	1340	0.57	1379	0.61
1100	1089	0.40	1136	0.43	1181	0.46	1225	0.50	1268	0.54	1308	0.58	1347	0.62	1386	0.66
1200	1104	0.45	1150	0.48	1194	0.51	1237	0.55	1279	0.59	1319	0.63	1357	0.67	1394	0.71
1300	1121	0.5	1165	0.53	1209	0.57	1251	0.61	1292	0.65	1331	0.69	1368	0.73	1405	0.78
1400	1140	0.56	1183	0.59	1225	0.63	1266	0.67	1306	0.71	1345	0.76	1382	0.8	1417	0.85
1500	1161	0.62	1202	0.65	1243	0.69	1284	0.73	1323	0.78	1360	0.83	1396	0.87	1432	0.92

BLOWER DATA

ZHB048

BLOWER TABLE INCLUDES RESISTANCE FOR BASE UNIT ONLY WITH DRY INDOOR COIL AND AIR FILTERS IN PLACE.

FOR ALL UNITS ADD:

1 - Any factory installed options air resistance (heat section, economizer, wet coil, etc.).

2 - Any field installed accessories air resistance (duct resistance, diffuser, etc.).

See page 19 for blower motors and drives and wet coil and options/accessory air resistance data.

DOWNFLOW

Air Volume cfm	External Static - in. w.g.															
	0.10		0.20		0.30		0.40		0.50		0.60		0.70		0.80	
	RPM	BHP	RPM	BHP	RPM	BHP	RPM	BHP	RPM	BHP	RPM	BHP	RPM	BHP	RPM	BHP
1200	620	0.23	681	0.29	744	0.34	809	0.39	875	0.43	941	0.47	1004	0.51	1060	0.54
1300	652	0.28	713	0.34	775	0.39	839	0.44	903	0.48	967	0.51	1025	0.55	1078	0.59
1400	687	0.33	747	0.39	809	0.44	871	0.49	934	0.53	994	0.57	1048	0.61	1098	0.64
1500	724	0.40	784	0.45	844	0.50	905	0.54	965	0.59	1021	0.62	1071	0.66	1118	0.70
1600	764	0.46	823	0.51	882	0.56	940	0.60	997	0.65	1048	0.69	1094	0.72	1140	0.75
1700	806	0.53	863	0.58	919	0.62	975	0.67	1028	0.71	1075	0.75	1119	0.78	1164	0.81
1800	849	0.60	903	0.65	957	0.69	1010	0.74	1058	0.78	1102	0.82	1145	0.85	1189	0.88
1900	892	0.68	944	0.72	995	0.77	1045	0.82	1089	0.86	1131	0.89	1174	0.92	1217	0.95
2000	935	0.76	984	0.81	1033	0.86	1079	0.91	1122	0.95	1163	0.97	1204	1.00	1247	1.03

Air Volume cfm	External Static - in. w.g.															
	0.90		1.00		1.10		1.20		1.30		1.40		1.50		1.60	
	RPM	BHP	RPM	BHP	RPM	BHP	RPM	BHP	RPM	BHP	RPM	BHP	RPM	BHP	RPM	BHP
1200	1111	0.58	1156	0.60	1199	0.62	1241	0.63	1284	0.65	1326	0.67	1367	0.71	1408	0.74
1300	1127	0.62	1172	0.65	1214	0.66	1256	0.68	1299	0.70	1341	0.73	1381	0.77	1421	0.81
1400	1145	0.68	1189	0.70	1231	0.72	1274	0.74	1316	0.76	1357	0.79	1397	0.83	1436	0.88
1500	1164	0.73	1208	0.75	1251	0.78	1293	0.80	1334	0.83	1374	0.86	1413	0.91	1451	0.95
1600	1185	0.79	1229	0.81	1271	0.84	1313	0.86	1354	0.90	1393	0.94	1431	0.98	1468	1.03
1700	1208	0.84	1252	0.87	1294	0.90	1335	0.94	1375	0.98	1413	1.02	1449	1.07	1485	1.12
1800	1233	0.91	1276	0.94	1318	0.98	1358	1.02	1397	1.06	1434	1.11	1469	1.16	1504	1.21
1900	1261	0.98	1303	1.02	1343	1.06	1382	1.11	1420	1.16	1455	1.21	1490	1.26	1525	1.31
2000	1289	1.07	1330	1.11	1370	1.16	1407	1.21	1444	1.27	1478	1.32	1513	1.37	1547	1.42

HORIZONTAL

Air Volume cfm	External Static - in. w.g.															
	0.10		0.20		0.30		0.40		0.50		0.60		0.70		0.80	
	RPM	BHP	RPM	BHP	RPM	BHP	RPM	BHP	RPM	BHP	RPM	BHP	RPM	BHP	RPM	BHP
1200	614	0.21	681	0.25	752	0.30	821	0.34	888	0.39	950	0.43	1006	0.46	1057	0.49
1300	644	0.24	712	0.29	782	0.34	850	0.39	915	0.43	974	0.47	1027	0.51	1076	0.53
1400	677	0.29	746	0.34	814	0.39	880	0.44	942	0.48	998	0.52	1049	0.55	1097	0.58
1500	714	0.34	781	0.40	848	0.45	911	0.49	970	0.53	1023	0.57	1072	0.60	1119	0.63
1600	752	0.40	818	0.45	882	0.50	943	0.55	999	0.59	1050	0.62	1097	0.66	1142	0.69
1700	792	0.46	855	0.52	917	0.56	975	0.61	1028	0.64	1077	0.68	1123	0.72	1166	0.75
1800	832	0.53	894	0.58	952	0.63	1007	0.67	1058	0.70	1105	0.74	1149	0.78	1192	0.82
1900	873	0.60	932	0.65	988	0.69	1040	0.73	1088	0.77	1134	0.81	1177	0.85	1219	0.90
2000	914	0.67	970	0.72	1023	0.76	1073	0.80	1120	0.85	1163	0.89	1205	0.94	1246	0.99

Air Volume cfm	External Static - in. w.g.															
	0.90		1.00		1.10		1.20		1.30		1.40		1.50		1.60	
	RPM	BHP	RPM	BHP	RPM	BHP	RPM	BHP	RPM	BHP	RPM	BHP	RPM	BHP	RPM	BHP
1200	1105	0.51	1152	0.53	1197	0.55	1240	0.58	1280	0.61	1320	0.64	1358	0.68	1395	0.72
1300	1123	0.55	1169	0.57	1213	0.60	1255	0.63	1295	0.67	1334	0.70	1372	0.74	1409	0.79
1400	1142	0.60	1187	0.63	1230	0.66	1272	0.69	1312	0.73	1350	0.77	1388	0.82	1424	0.86
1500	1163	0.66	1207	0.69	1249	0.72	1290	0.76	1330	0.80	1368	0.85	1405	0.90	1441	0.94
1600	1185	0.72	1228	0.75	1270	0.79	1310	0.83	1349	0.88	1387	0.93	1423	0.98	1459	1.03
1700	1209	0.78	1251	0.82	1292	0.87	1331	0.92	1370	0.97	1407	1.02	1443	1.07	1478	1.12
1800	1234	0.86	1275	0.91	1315	0.96	1354	1.01	1391	1.06	1428	1.11	1463	1.17	1498	1.22
1900	1260	0.95	1300	1.00	1340	1.05	1377	1.11	1414	1.16	1450	1.22	1485	1.27	1519	1.32
2000	1287	1.04	1326	1.10	1365	1.16	1402	1.21	1437	1.27	1472	1.33	1507	1.38	1541	1.43

BLOWER DATA

ZHB060

BLOWER TABLE INCLUDES RESISTANCE FOR BASE UNIT ONLY WITH DRY INDOOR COIL AND AIR FILTERS IN PLACE.

FOR ALL UNITS ADD:

1 - Any factory installed options air resistance (heat section, economizer, wet coil, etc.).

2 - Any field installed accessories air resistance (duct resistance, diffuser, etc.).

See page 19 for blower motors and drives and wet coil and options/accessory air resistance data.

DOWNFLOW

Air Volume cfm	External Static - in. w.g.															
	0.10		0.20		0.30		0.40		0.50		0.60		0.70		0.80	
	RPM	BHP	RPM	BHP	RPM	BHP	RPM	BHP	RPM	BHP	RPM	BHP	RPM	BHP	RPM	BHP
1600	522	0.27	552	0.32	585	0.37	619	0.43	656	0.48	693	0.53	732	0.59	771	0.64
1700	539	0.32	570	0.37	603	0.43	638	0.48	674	0.53	711	0.59	749	0.64	787	0.69
1800	558	0.38	589	0.43	623	0.48	658	0.54	694	0.59	730	0.64	767	0.70	803	0.75
1900	578	0.44	610	0.49	643	0.54	678	0.60	714	0.65	749	0.70	785	0.76	819	0.82
2000	600	0.50	632	0.56	665	0.61	699	0.66	734	0.71	769	0.77	803	0.83	837	0.90
2100	623	0.57	655	0.62	688	0.68	721	0.73	755	0.79	789	0.84	822	0.91	854	0.98
2200	647	0.65	678	0.70	711	0.75	743	0.81	776	0.86	809	0.93	841	1.00	872	1.06
2300	671	0.73	702	0.78	734	0.83	766	0.89	798	0.95	829	1.02	860	1.09	890	1.16
2400	696	0.81	726	0.87	757	0.92	788	0.98	819	1.04	850	1.11	880	1.19	909	1.26

Air Volume cfm	External Static - in. w.g.															
	0.90		1.00		1.10		1.20		1.30		1.40		1.50		1.60	
	RPM	BHP	RPM	BHP	RPM	BHP	RPM	BHP	RPM	BHP	RPM	BHP	RPM	BHP	RPM	BHP
1600	809	0.69	844	0.74	877	0.80	908	0.85	936	0.91	963	0.97	989	1.02	1014	1.08
1700	823	0.75	857	0.80	889	0.86	919	0.92	947	0.97	973	1.03	999	1.09	1024	1.14
1800	838	0.81	870	0.87	901	0.92	931	0.98	958	1.04	984	1.10	1009	1.16	1034	1.22
1900	853	0.88	885	0.94	915	0.99	944	1.05	971	1.11	996	1.17	1021	1.23	1045	1.29
2000	869	0.96	899	1.01	929	1.07	957	1.13	984	1.19	1009	1.25	1033	1.31	1058	1.38
2100	885	1.04	915	1.10	944	1.15	971	1.22	997	1.28	1022	1.34	1046	1.40	1070	1.46
2200	902	1.13	931	1.19	959	1.24	986	1.31	1012	1.37	1036	1.43	1060	1.50	1084	1.56
2300	920	1.23	948	1.29	975	1.35	1001	1.41	1027	1.47	1051	1.53	1075	1.60	1098	1.66
2400	938	1.33	965	1.39	992	1.45	1017	1.52	1042	1.58	1066	1.64	1090	1.70	1113	1.77

HORIZONTAL

Air Volume cfm	External Static - in. w.g.															
	0.10		0.20		0.30		0.40		0.50		0.60		0.70		0.80	
	RPM	BHP	RPM	BHP	RPM	BHP	RPM	BHP	RPM	BHP	RPM	BHP	RPM	BHP	RPM	BHP
1600	525	0.30	561	0.34	597	0.39	635	0.43	673	0.47	711	0.51	748	0.56	784	0.61
1700	543	0.34	578	0.39	615	0.43	653	0.48	691	0.52	728	0.57	765	0.62	800	0.67
1800	561	0.39	597	0.44	635	0.49	672	0.53	710	0.58	746	0.63	782	0.68	816	0.73
1900	581	0.44	618	0.49	655	0.54	692	0.59	729	0.64	765	0.69	800	0.75	833	0.80
2000	602	0.50	639	0.55	676	0.61	713	0.66	749	0.71	784	0.76	818	0.82	850	0.88
2100	625	0.57	661	0.62	698	0.67	735	0.73	770	0.78	804	0.84	837	0.90	868	0.96
2200	648	0.64	685	0.69	721	0.75	757	0.80	791	0.86	824	0.92	856	0.98	886	1.05
2300	673	0.71	709	0.77	745	0.83	780	0.88	813	0.94	845	1.01	876	1.08	905	1.15
2400	699	0.79	734	0.85	769	0.91	803	0.97	835	1.04	866	1.11	896	1.18	924	1.25

Air Volume cfm	External Static - in. w.g.															
	0.90		1.00		1.10		1.20		1.30		1.40		1.50		1.60	
	RPM	BHP	RPM	BHP	RPM	BHP	RPM	BHP	RPM	BHP	RPM	BHP	RPM	BHP	RPM	BHP
1600	819	0.66	851	0.72	883	0.77	913	0.83	943	0.89	971	0.95	998	1.01	1024	1.07
1700	833	0.72	865	0.78	896	0.84	926	0.90	954	0.96	982	1.02	1009	1.08	1034	1.14
1800	848	0.79	880	0.85	910	0.92	939	0.98	967	1.04	994	1.10	1020	1.16	1045	1.23
1900	864	0.87	895	0.93	924	0.99	953	1.06	980	1.12	1007	1.18	1032	1.25	1056	1.31
2000	881	0.95	911	1.01	940	1.08	967	1.14	994	1.21	1020	1.27	1044	1.34	1068	1.40
2100	898	1.03	927	1.10	955	1.17	982	1.23	1008	1.30	1033	1.37	1057	1.43	1080	1.50
2200	916	1.12	944	1.19	971	1.26	998	1.33	1023	1.40	1047	1.47	1071	1.54	1093	1.60
2300	934	1.22	961	1.29	988	1.36	1014	1.43	1038	1.50	1062	1.58	1085	1.65	1107	1.71
2400	952	1.32	979	1.40	1005	1.47	1030	1.54	1054	1.62	1077	1.69	1099	1.76	1121	1.83

BLOWER DATA

DRIVE KIT SPECIFICATIONS - ZHB036-048

Model No.	Motor HP		No. of Speeds	Drive Kits and RPM Range					
	Nominal	Maximum		ZA01	ZA02	ZA03	ZA04	³ ZA05	³ ZA06
ZHB036	¹ 0.75	0.86	1	678 - 1035	---	---	964 - 1471	---	---
	² 1	1.15	1	678 - 1035	---	---	964 - 1471	---	---
	¹ 1.5	1.7	1	678 - 1035	---	---	964 - 1471	---	---
ZHB048	¹ 0.75	0.86	1	---	803 - 1226	---	---	---	---
	² 1	1.15	1	---	803 - 1226	---	---	---	---
	¹ 1.5	1.7	1	---	803 - 1226	---	---	1098 - 1490	---

DRIVE KIT SPECIFICATIONS - ZHB060-072

Model No.	Motor HP		No. of Speeds	Drive Kits and RPM Range			
	Nominal	Maximum		ZAA01	ZAA02	³ ZAA03	⁴ ZAA04
ZHB060	¹ 0.75	0.86	1	522 - 784	632 - 875	---	---
	² 1	1.15	1	522 - 784	632 - 875	---	---
	1.5	1.7	1	522 - 784	632 - 875	798 - 1105	---
ZHB072	1	1.15	1	---	632 - 875	---	---
	1.5	1.7	1	---	632 - 875	798 - 1105	---
	2	2.3	1	---	632 - 875	798 - 1105	921 - 1228

NOTE - Using total air volume and system static pressure requirements determine from blower performance tables rpm and motor hp required. Maximum usable hp of motors furnished are shown. In Canada, nominal motor hp is also maximum usable motor hp. If motors of comparable hp are used, be sure to keep within the service factor limitations outlined on the motor nameplate.

¹ 0.75 and 1.5 hp motors are only available for ZHB036-060 208/230V-1ph applications.

² 1 hp blower motor is not available for ZHB060 208/230V-1ph applications.

³ 1.5 hp blower motor is the minimum required with the ZA05, ZA06, and ZAA03 drive kits.

⁴ 2 hp blower motor is required with the ZAA04 drive kit.

POWER EXHAUST FAN PERFORMANCE

Return Air System Static Pressure - in. w.g.	Air Volume Exhausted cfm
0.00	1865
0.05	1785
0.10	1710
0.15	1630
0.20	1545
0.25	1450
0.30	1350
0.35	1240

BLOWER DATA

OPTIONS / ACCESSORIES AIR RESISTANCE - in. w.g.

Air Volume cfm				Electric Heat	Economizer	
	036	048, 060	072		Downflow	Horizontal
900	0.01	---	---	0.05	0.03	0.04
1000	0.01	---	---	0.06	0.03	0.05
1100	0.02	---	---	0.08	0.04	0.05
1200	0.02	0.01	---	0.09	0.05	0.06
1300	0.02	0.02	---	0.12	0.05	0.07
1400	0.03	0.02	---	0.17	0.06	0.08
1500	0.03	0.02	---	0.22	0.07	0.08
1600	0.03	0.03	0.03	0.26	0.08	0.09
1700	0.04	0.03	0.03	0.30	0.09	0.10
1800	0.04	0.03	0.03	0.33	0.10	0.11
1900	0.05	0.04	0.04	0.33	0.11	0.12
2000	0.05	0.04	0.04	0.31	0.12	0.13
2100	0.06	0.05	0.05	0.27	0.13	0.14
2200	0.06	0.05	0.05	0.29	0.14	0.15
2300	0.07	0.05	0.05	0.31	0.15	0.16
2400	0.07	0.06	0.06	0.32	0.16	0.18
2500	---	---	0.06	0.34	0.18	0.19
2600	---	---	0.07	0.38	0.19	0.20
2700	---	---	0.07	0.42	0.20	0.21
2800	---	---	0.07	0.45	0.22	0.23
2900	---	---	0.08	0.49	0.23	0.24

BLOWER DATA

CEILING DIFFUSERS AIR RESISTANCE (in. w.g.)

Air Volume cfm	RTD9-65S Step-Down Diffuser			FD9-65S Flush Diffuser	RTD11-95S Step-Down Diffuser			FD11-95S Flush Diffuser
	2 Ends Open	1 Side & 2 Ends Open	All Ends & Sides Open		2 Ends Open	1 Side & 2 Ends Open	All Ends & Sides Open	
800	0.15	0.13	0.11	0.11	---	---	---	---
1000	0.19	0.16	0.14	0.14	---	---	---	---
1200	0.25	0.20	0.17	0.17	---	---	---	---
1400	0.33	0.26	0.20	0.20	---	---	---	---
1600	0.43	0.32	0.20	0.24	---	---	---	---
1800	0.56	0.40	0.30	0.30	0.13	0.11	0.09	0.09
2000	0.73	0.50	0.36	0.36	0.15	0.13	0.11	0.10
2200	0.95	0.63	0.44	0.44	0.18	0.15	0.12	0.12
2400	---	----	---	---	0.21	0.18	0.15	0.14
2600	---	----	---	---	0.24	0.21	0.18	0.17
2800	---	----	---	---	0.27	0.24	0.21	0.20
3000	---	----	---	---	0.32	0.29	0.25	0.25
3200	---	----	---	---	0.41	0.37	0.32	0.31
3400	---	----	---	---	0.50	0.45	0.39	0.37
3600	---	----	---	---	0.61	0.54	0.48	0.44

CEILING DIFFUSER AIR THROW DATA

Air Volume - cfm	¹ Effective Throw - ft.	
Model No.	RTD9-65S	FD9-65S
800	10 - 17	14 - 18
1000	10 - 17	15 - 20
1200	11 - 18	16 - 22
1400	12 - 19	17 - 24
1600	12 - 20	18 - 25
1800	13 - 21	20 - 28
2000	14 - 23	21 - 29
2200	16 - 25	22 - 30
Model No.	RTD11-95S	FD11-95S
2600	24 - 29	19 - 24
2800	25 - 30	20 - 28
3000	27 - 33	21 - 29
3200	28 - 35	22 - 29
3400	30 - 37	22 - 30
3600	25 - 33	22 - 24

¹ Effective throw based on terminal velocities of 75 ft. per minute.

ELECTRICAL/ELECTRIC HEAT DATA

3 TON

Model No.		ZHB036S4							
¹ Voltage - 60Hz		208/230V - 1 Ph		208/230V - 3 Ph		460V - 3 Ph		575V - 3 Ph	
Compressor	Rated Load Amps	15.3		8.7		4		3.6	
	Locked Rotor Amps	70		70		31		27	
Outdoor Fan Motor	Full Load Amps	1		1		0.6		0.45	
Power Exhaust (1) 0.5 HP	Full Load Amps	1.5		1.5		0.6		0.6	
Indoor Blower Motor	Horsepower	0.75	1.5	1	1.5	1	1.5	1	1.5
	Full Load Amps	7.6	11	4.6	6.6	2.1	3	1.7	2.4
² Maximum Overcurrent Protection	Unit Only	40	45	25	25	15	15	15	15
	With (1) 0.5 HP Power Exhaust	40	45	25	25	15	15	15	15
³ Minimum Circuit Ampacity	Unit Only	28	32	17	19	8	9	7	8
	With (1) 0.5 HP Power Exhaust	30	33	18	20	9	10	8	8

ELECTRIC HEAT DATA

Electric Heat Voltage			208	240	208	240	240	240	480	480	600	600
² Maximum Overcurrent Protection	Unit+ Electric Heat	5 kW	60	60	60	60	35	35	15	20	15	15
		7.5 kW	70	70	70	80	40	45	20	20	20	20
		10 kW	80	80	80	90	50	50	25	25	20	20
		15 kW	100	110	100	110	70	70	30	35	25	30
³ Minimum Circuit Ampacity	Unit+ Electric Heat	5 kW	51	54	54	58	32	34	15	17	13	14
		7.5 kW	62	67	65	71	40	42	19	20	16	17
		10 kW	73	80	77	84	47	49	23	24	19	20
		15 kW	96	106	99	110	62	64	30	32	25	26
² Maximum Overcurrent Protection	Unit+ Electric Heat and (1) 0.5 HP Power Exhaust	5 kW	60	60	60	60	35	40	20	20	15	15
		7.5 kW	70	70	70	80	45	45	20	25	20	20
		10 kW	80	90	80	90	50	60	25	25	20	20
		15 kW	100	110	110	125	70	70	35	35	25	30
³ Minimum Circuit Ampacity	Unit+ Electric Heat and (1) 0.5 HP Power Exhaust	5 kW	52	56	56	59	34	36	16	17	13	14
		7.5 kW	64	69	67	72	41	43	20	21	16	17
		10 kW	75	82	78	85	49	51	23	25	19	20
		15 kW	97	108	101	111	64	66	31	32	25	26

ELECTRIC HEAT ACCESSORIES

Unit Fuse Block	Unit Only	10A26	10A26	10A27	10A29	10A29
	Unit + Power Exhaust	10A26	10A26	10A27	10A29	10A29

NOTE - All units have a minimum Short Circuit Current Rating (SCCR) of 5000 amps.

¹ Extremes of operating range are plus and minus 10% of line voltage.

² HACR type breaker or fuse.

³ Refer to National or Canadian Electrical Code manual to determine wire, fuse and disconnect size requirements.

ELECTRICAL/ELECTRIC HEAT DATA

4 TON

Model No.		ZHB048S4							
¹ Voltage - 60Hz		208/230V - 1 Ph		208/230V - 3 Ph		460V - 3 Ph		575V - 3 Ph	
Compressor	Rated Load Amps	20		11		5.5		4.7	
	Locked Rotor Amps	99		86		37		34	
Outdoor Fan Motor	Full Load Amps	1.7		1.7		0.9		0.7	
Power Exhaust (1) 0.5 HP	Full Load Amps	1.5		1.5		0.6		0.6	
Indoor Blower Motor	Horsepower	0.75	1.5	1	1.5	1	1.5	1	1.5
	Full Load Amps	7.6	11	4.6	6.6	2.1	3	1.7	2.4
² Maximum Overcurrent Protection	Unit Only	50	50	30	30	15	15	15	15
	With (1) 0.5 HP Power Exhaust	50	50	30	30	15	15	15	15
³ Minimum Circuit Ampacity	Unit Only	35	38	21	23	10	11	9	9
	With (1) 0.5 HP Power Exhaust	36	40	22	24	11	12	9	10

ELECTRIC HEAT DATA

Electric Heat Voltage			208	240	208	240	208	240	208	240	480	480	600	600
² Maximum Overcurrent Protection	Unit+ Electric Heat	5 kW	70	70	70	70	40	40	40	45	20	20	15	15
		7.5 kW	80	80	80	80	45	45	45	50	25	25	20	20
		10 kW	90	90	90	90	50	60	50	60	25	30	25	25
		15 kW	110	125	110	125	60	70	70	70	35	35	30	30
		22 kW	150	175	150	175	80	90	90	90	45	45	40	40
³ Minimum Circuit Ampacity	Unit+ Electric Heat	5 kW	57	61	61	64	34	36	36	38	18	19	15	15
		7.5 kW	69	74	72	77	40	43	42	45	22	23	18	18
		10 kW	80	87	83	90	47	51	49	53	25	26	21	22
		15 kW	103	113	106	116	60	66	62	68	33	34	27	28
		22 kW	136	152	140	155	79	88	81	90	44	45	36	37
² Maximum Overcurrent Protection	Unit+ Electric Heat and (1) 0.5 HP Power Exhaust	5 kW	70	70	70	80	40	40	40	45	20	20	15	20
		7.5 kW	80	80	80	90	45	50	50	50	25	25	20	20
		10 kW	90	90	90	100	50	60	50	60	30	30	25	25
		15 kW	110	125	110	125	70	70	70	70	35	35	30	30
		22 kW	150	175	150	175	90	90	90	100	45	50	40	40
³ Minimum Circuit Ampacity	Unit+ Electric Heat and (1) 0.5 HP Power Exhaust	5 kW	59	62	62	66	35	37	37	39	18	19	15	16
		7.5 kW	70	75	74	79	42	45	44	47	22	23	18	19
		10 kW	81	88	85	92	48	52	50	54	26	27	21	22
		15 kW	104	114	107	118	61	67	63	69	34	34	27	28
		22 kW	138	153	141	157	81	90	83	92	45	46	36	37

ELECTRIC HEAT ACCESSORIES

Unit Fuse Block	Unit Only	10A26	10A26	10A27	10A27	10A29	10A29
	Unit + Power Exhaust	10A26	10A26	10A27	10A27	10A29	10A29

NOTE - All units have a minimum Short Circuit Current Rating (SCCR) of 5000 amps.

¹ Extremes of operating range are plus and minus 10% of line voltage.

² HACR type breaker or fuse.

³ Refer to National or Canadian Electrical Code manual to determine wire, fuse and disconnect size requirements.

ELECTRICAL/ELECTRIC HEAT DATA

5 TON

Model No.		ZHB060S4							
¹ Voltage - 60Hz		208/230V - 1 Ph		208/230V - 3 Ph		460V - 3 Ph		575V - 3 Ph	
Compressor	Rated Load Amps	22.1		13.5		8		5	
	Locked Rotor Amps	125		109		59		40	
Outdoor Fan Motor	Full Load Amps	1.7		1.7		1		0.9	
Power Exhaust (1) 0.5 HP	Full Load Amps	1.5		1.5		0.6		0.6	
Indoor Blower Motor	Horsepower	0.75	1.5	1	1.5	1	1.5	1	1.5
	Full Load Amps	7.6	11	4.6	6.6	2.1	3	1.7	2.4
² Maximum Overcurrent Protection	Unit Only	50	60	35	35	20	20	15	15
	With (1) 0.5 HP Power Exhaust	60	60	35	40	20	20	15	15
³ Minimum Circuit Ampacity	Unit Only	37	41	24	26	14	14	9	10
	With (1) 0.5 HP Power Exhaust	39	42	25	27	14	15	10	11

ELECTRIC HEAT DATA

Electric Heat Voltage			208	240	208	240	208	240	208	240	480	480	600	600
² Maximum Overcurrent Protection	Unit+ Electric Heat	5 kW	70	70	80	80	45	45	45	50	25	25	15	20
		7.5 kW	80	90	80	90	50	50	50	50	25	30	20	20
		10 kW	90	100	90	100	50	60	60	60	30	30	25	25
		15 kW	110	125	110	125	70	70	70	80	40	40	30	30
		22 kW	150	175	150	175	90	90	90	100	50	50	40	40
³ Minimum Circuit Ampacity	Unit+ Electric Heat	5 kW	60	63	63	67	36	38	39	41	21	22	15	16
		7.5 kW	71	76	75	80	42	45	45	48	24	26	18	19
		10 kW	83	90	86	93	49	53	52	56	28	30	21	22
		15 kW	105	116	109	119	62	68	65	71	36	37	27	28
		22 kW	139	155	142	158	81	90	84	93	47	48	36	37
² Maximum Overcurrent Protection	Unit+ Electric Heat and (1) 0.5 HP Power Exhaust	5 kW	70	80	80	80	45	45	50	50	25	25	20	20
		7.5 kW	80	90	90	90	50	50	50	50	30	30	20	20
		10 kW	90	100	100	100	50	60	60	60	30	30	25	25
		15 kW	110	125	110	125	70	70	70	80	40	40	30	30
		22 kW	150	175	150	175	90	100	90	100	50	50	40	40
³ Minimum Circuit Ampacity	Unit+ Electric Heat and (1) 0.5 HP Power Exhaust	5 kW	61	65	65	68	37	39	40	42	21	23	16	17
		7.5 kW	73	78	76	81	44	47	47	50	25	26	19	20
		10 kW	84	91	87	94	50	54	53	57	29	30	22	23
		15 kW	107	117	110	120	63	69	66	72	36	38	28	29
		22 kW	140	156	144	160	83	92	86	95	48	49	37	38

ELECTRIC HEAT ACCESSORIES

Unit Fuse Block	Unit Only	10A26	10A26	10A28	10A28	10A29	10A29
	Unit + Power Exhaust	10A26	10A26	10A28	10A28	10A29	10A29

NOTE - All units have a minimum Short Circuit Current Rating (SCCR) of 5000 amps.

¹ Extremes of operating range are plus and minus 10% of line voltage.

² HACR type breaker or fuse.

³ Refer to National or Canadian Electrical Code manual to determine wire, fuse and disconnect size requirements.

ELECTRICAL/ELECTRIC HEAT DATA

6 TON

Model No.		ZHB072S4								
¹ Voltage - 60Hz		208/230V - 3 Ph			460V - 3 Ph			575V - 3 Ph		
Compressor	Rated Load Amps	22.4			10.6			7.7		
	Locked Rotor Amps	149			75			54		
Outdoor Fan Motor	Full Load Amps	2.4			1.3			1		
Power Exhaust (1) 0.5 HP	Full Load Amps	1.5			0.6			0.6		
Indoor Blower Motor	Horsepower	1	1.5	2	1	1.5	2	1	1.5	2
	Full Load Amps	4.6	6.6	7.5	2.1	3	3.4	1.7	2.4	2.7
² Maximum Overcurrent Protection	Unit Only	50	50	60	25	25	25	20	20	20
	With (1) 0.5 HP Power Exhaust	50	60	60	25	25	25	20	20	20
³ Minimum Circuit Ampacity	Unit Only	35	37	38	17	18	18	13	14	14
	With (1) 0.5 HP Power Exhaust	37	39	40	18	19	19	13	14	14

ELECTRIC HEAT DATA

Electric Heat Voltage			208	240	208	240	208	240	480	480	480	600	600	600
² Maximum Overcurrent Protection	Unit+ Electric Heat	7.5 kW	70	70	70	70	70	70	35	35	35	25	25	25
		10 kW	70	80	80	80	80	80	35	40	40	25	30	30
		15 kW	80	90	90	90	90	90	45	45	45	35	35	35
		22 kW	100	110	100	110	100	110	60	60	60	40	45	45
		30 kW	125	150	125	150	125	150	70	70	70	50	50	50
³ Minimum Circuit Ampacity	Unit+ Electric Heat	7.5 kW	55	58	57	60	58	61	28	29	30	22	23	23
		10 kW	62	66	64	68	64	68	32	33	33	25	26	26
		15 kW	75	81	77	83	77	84	40	41	41	31	32	32
		22 kW	94	103	96	105	97	106	51	52	52	40	41	41
		30 kW	114	126	116	128	117	129	62	63	64	49	50	50
² Maximum Overcurrent Protection	Unit+ Electric Heat and (1) 0.5 HP Power Exhaust	7.5 kW	70	70	70	70	70	70	35	35	35	25	25	25
		10 kW	70	80	80	80	80	80	35	40	40	30	30	30
		15 kW	90	90	90	90	90	90	45	45	45	35	35	35
		22 kW	100	110	100	110	100	110	60	60	60	40	45	45
		30 kW	125	150	125	150	125	150	70	70	70	50	50	60
³ Minimum Circuit Ampacity	Unit+ Electric Heat and (1) 0.5 HP Power Exhaust	7.5 kW	57	60	59	62	59	62	29	30	30	22	23	23
		10 kW	63	67	65	69	66	70	33	34	34	25	26	26
		15 kW	76	82	78	84	79	85	40	41	42	31	32	32
		22 kW	96	105	98	107	99	108	52	52	53	40	41	41
		30 kW	115	127	117	129	118	130	63	64	64	50	50	51

ELECTRIC HEAT ACCESSORIES

Unit Fuse Block	Unit Only	10A28	10A28	10A28	10A29	10A29
	Unit + Power Exhaust	10A28	10A28	10A28	10A29	10A29

NOTE - All units have a minimum Short Circuit Current Rating (SCCR) of 5000 amps.

¹ Extremes of operating range are plus and minus 10% of line voltage.

² HACR type breaker or fuse.

³ Refer to National or Canadian Electrical Code manual to determine wire, fuse and disconnect size requirements.

ELECTRIC HEAT CAPACITIES

Input Voltage	5 kW			7.5 kW			10 kW		
	No of Stages	kW input	Btuh Output	No of Stages	kW input	Btuh Output	No of Stages	kW input	Btuh Output
208	1	3.8	12,800	1	5.6	19,200	1	7.5	25,600
220	1	4.2	14,300	1	6.3	21,500	1	8.4	28,700
230	1	4.6	15,700	1	6.9	23,500	1	9.2	31,400
240	1	5.0	17,100	1	7.5	25,600	1	10.0	34,200
440	1	4.2	14,300	1	6.3	21,500	1	8.4	28,700
460	1	4.6	15,700	1	6.9	23,500	1	9.2	31,400
480	1	5.0	17,100	1	7.5	25,600	1	10.0	34,200
550	1	4.2	14,300	1	6.3	21,500	1	8.4	28,700
575	1	4.6	15,700	1	6.9	23,500	1	9.2	31,400
600	1	5.0	17,100	1	7.5	25,600	1	10.0	34,200
Input Voltage	15 kW			22.5 kW			30 kW		
	No of Stages	kW input	Btuh Output	No of Stages	kW input	Btuh Output	No of Stages	kW input	Btuh Output
208	1	11.2	38,400	1	16.9	57,700	1	22.5	76,800
220	1	12.6	43,000	1	18.9	64,500	1	25.2	86,000
230	1	13.8	47,000	1	20.7	70,700	1	27.5	93,900
240	1	15.0	51,200	1	22.5	76,800	1	30.0	102,400
440	1	12.6	43,000	1	18.9	64,500	1	25.2	86,000
460	1	13.8	47,000	1	20.7	70,700	1	27.5	93,900
480	1	15.0	51,200	1	22.5	76,800	1	30.0	102,400
550	1	12.6	43,000	1	18.9	64,500	1	25.2	86,000
575	1	13.8	47,000	1	20.7	70,700	1	27.5	93,900
600	1	15.0	51,200	1	22.5	76,800	1	30.0	102,400

OUTDOOR SOUND DATA

Unit Model No.	Octave Band Sound Power Levels dBA, re 10 ⁻¹² Watts - Center Frequency - Hz							¹ Sound Rating Number dBA
	125	250	500	1000	2000	4000	8000	
ZHB036	66	70	75	73	71	67	60	79
ZHB048	62	69	73	72	69	65	57	78
ZHB060	70	72	78	75	72	70	66	82
ZHB072	70	77	81	80	76	73	69	86

¹ Sound Rating Number according to AHRI Standard 270-2008. Sound Rating Number is the overall A-Weighted Sound Power Level, (LWA), dB (100 Hz to 10,000 Hz).

UNIT CLEARANCES

UNIT WITH DOWNFLOW ECONOMIZER

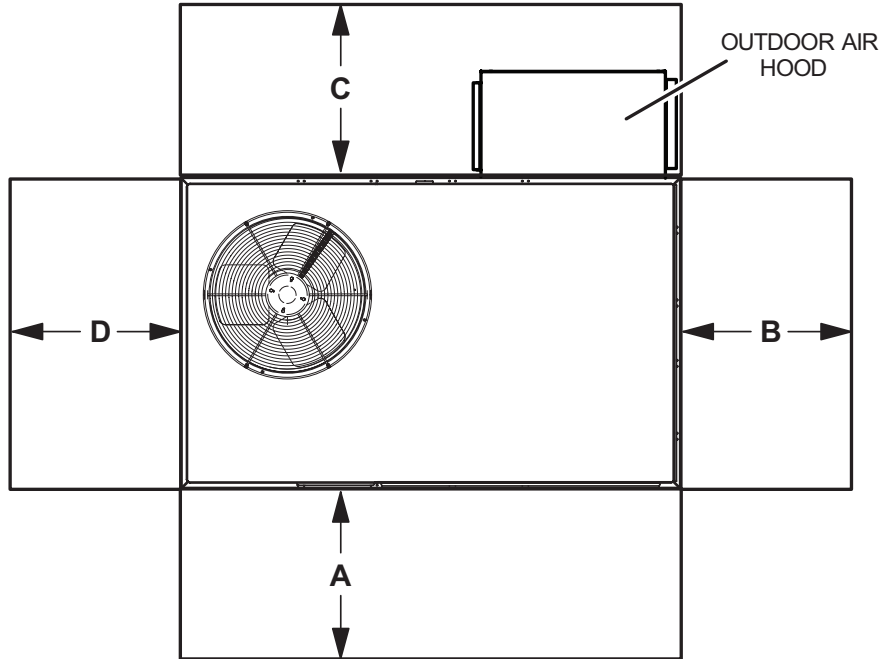

UNIT WITH HORIZONTAL ECONOMIZER

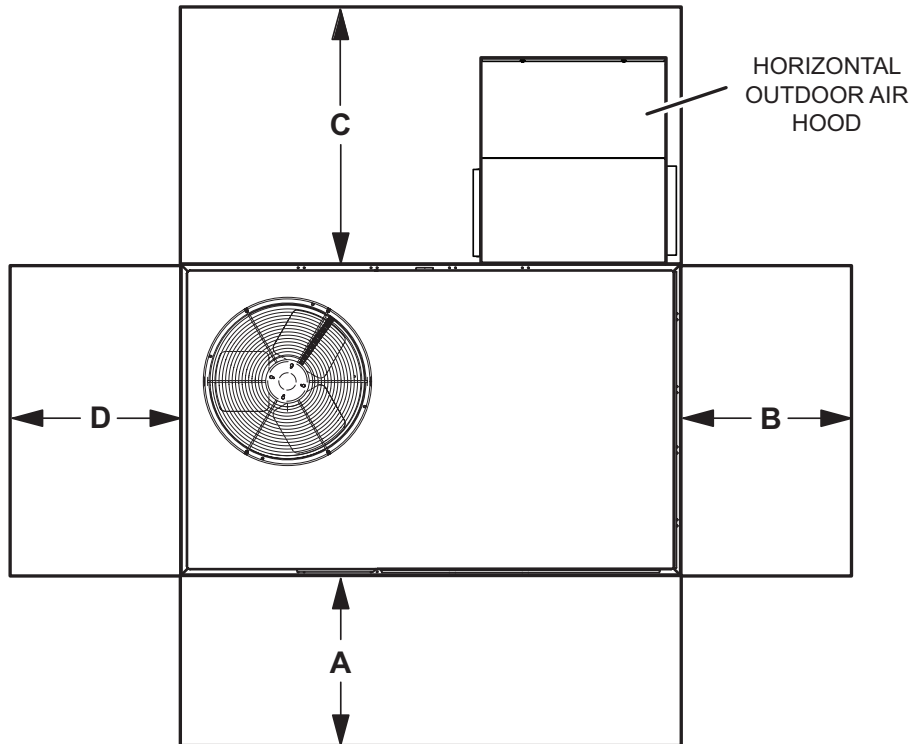

¹ Unit Clearance	A		B		C Downflow		C Horizontal		D		Top Clearance
	in.	mm	in.	mm	in.	mm	in.	mm	in.	mm	
Service Clearance	36	914	36	914	36	914	60	1524	36	914	Unobstructed
Minimum Operation Clearance	36	914	36	914	36	914	60	1524	36	914	

NOTE - Entire perimeter of unit base requires support when elevated above the mounting surface.

¹ Service Clearance - Required for removal of serviceable parts.

Minimum Operation Clearance - Required clearance for proper unit operation.

WEIGHT DATA

Model Number	Net				Shipping			
	Base		Max.		Base		Max.	
	lbs.	kg	lbs.	kg	lbs.	kg	lbs.	kg
ZHB036S	580	263	634	288	585	265	639	290
ZHB048S	585	265	639	290	590	268	644	292
ZHB060S	610	277	664	301	615	279	669	303
ZHB072S	683	310	702	318	715	324	735	333

Base Unit - The unit with NO OPTIONS.

Max. Unit - The unit with ALL OPTIONS Installed. (Economizer, etc.)

OPTIONS / ACCESSORIES

		Shipping Weights	
		lbs.	kg
ECONOMIZER			
Economizer			
Economizer, Includes Outdoor Air Hood and Barometric Relief Dampers with Hood	Downflow	62	28
	Horizontal	92	42
OUTDOOR AIR			
Outdoor Air Dampers			
Motorized		39	18
Manual		29	13
POWER EXHAUST			
Standard Static	Downflow	54	24
	Horizontal	41	19
ELECTRIC HEAT			
		5 kW	11
		7.5 kW	12
		10 kW	12
		15 kW	12
		22.5 kW	13
		30 kW	14
ROOF CURBS			
Hybrid Roof Curbs, Downflow			
8 in. height	Z1CURB70A-1	63	29
14 in. height	Z1CURB71A-1	83	38
18 in. height	Z1CURB72A-1	93	42
24 in. height	Z1CURB73A-1	113	51
CEILING DIFFUSERS			
Step-Down	RTD9-65S	80	36
	RTD11-95S	118	54
Flush	FD9-65S	80	36
	FD11-95S	118	54

DIMENSIONS - UNIT

Model No.	CORNER WEIGHTS																CENTER OF GRAVITY							
	AA				BB				CC				DD				EE				FF			
	Base		Max.		Base		Max.		Base		Max.		Base		Max.		Base		Max.		Base		Max.	
	lbs.	kg	lbs.	kg	lbs.	kg	lbs.	kg	lbs.	kg	lbs.	kg	lbs.	kg	lbs.	kg	in.	mm	in.	mm	in.	mm	in.	mm
036	158	72	173	78	133	60	145	66	124	56	135	61	147	67	160	73	41.25	1048	39.25	997	24.5	622	25.75	654
048	168	76	183	83	136	62	148	67	120	54	130	59	148	67	161	73	42	1067	40	1016	25	635	26.5	673
060	163	74	177	80	142	64	155	70	142	64	155	70	163	74	177	80	40.5	1029	38.5	978	23.5	597	25	635
072	149	68	143	65	200	91	200	91	191	87	209	95	143	65	150	68	42	1067	41	1041	24	610	23	584

Base Unit - The unit with NO OPTIONS.

Max. Unit - The unit with ALL OPTIONS Installed. (Economizer, largest blower motor, etc.).

BOTTOM POWER ENTRY

Holes required for Optional Bottom Power Entry Kit

	Threaded Conduit Fittings (Provided in Kit)	Wire Use	Hole Diameter Required in Unit Base (Max.)
E	1/2	ACC	7/8 (23)
F	1/2	24V	7/8 (23)
G	3/4	POWER	1-1/8 (29)

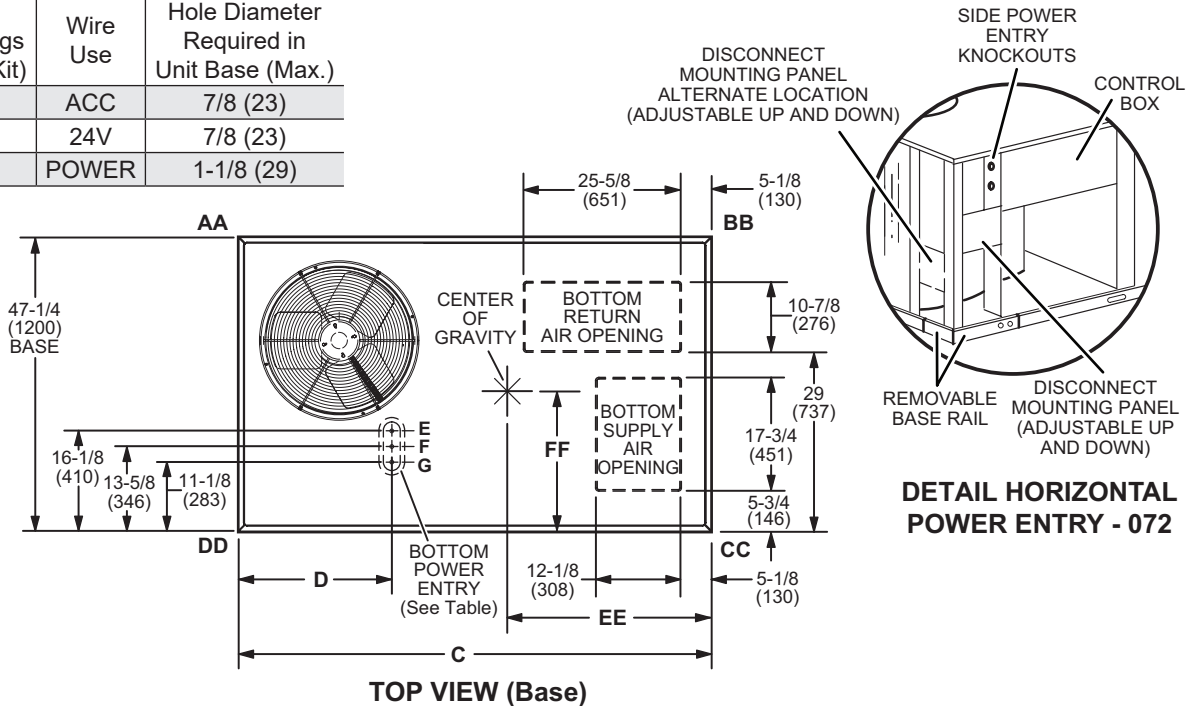

DETAIL HORIZONTAL POWER ENTRY - 072

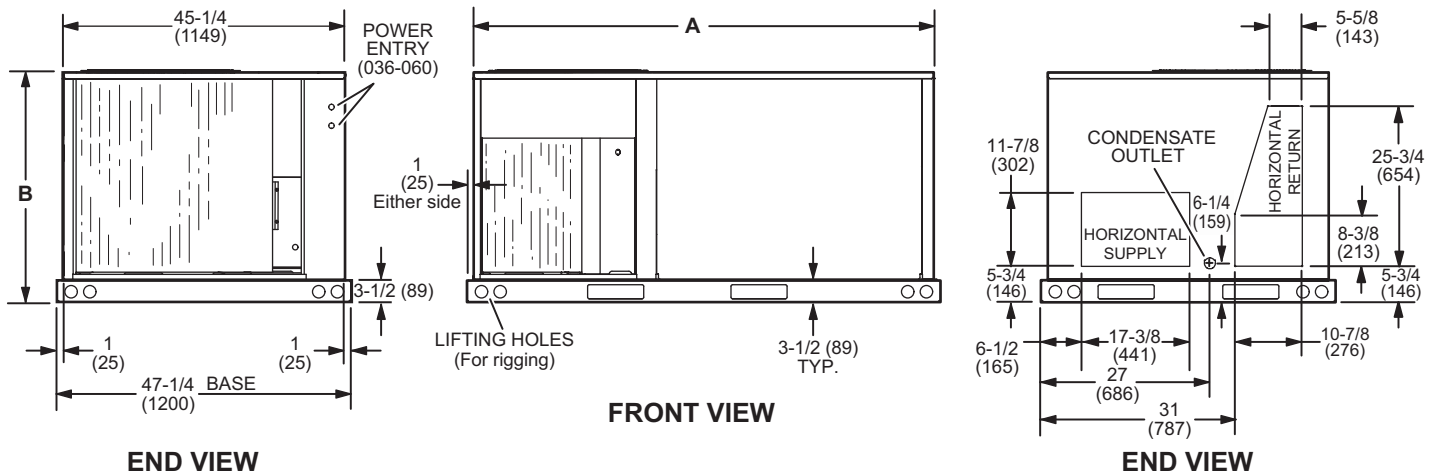

Model Number	A		B		C	
	in.	mm	in.	mm	in.	mm
ZHB036, 048	73-3/4	1873	75-7/8	1927	24-5/8	625
ZHB060	73-3/4	1873	75-7/8	1927	24-5/8	625
ZHB072	83-1/4	2115	85-1/4	2165	34	864

**OUTDOOR AIR HOOD DETAIL FOR OPTIONAL ECONOMIZER
(Downflow Applications)**

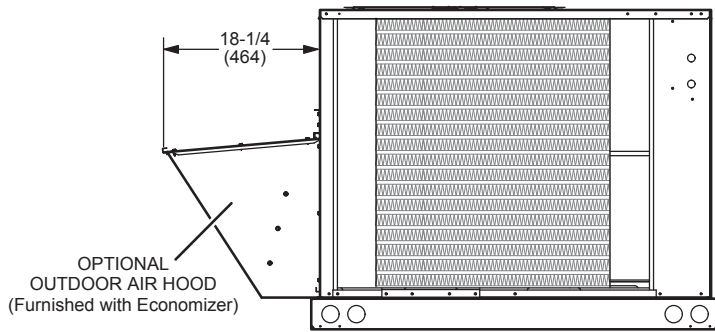

SIDE VIEW

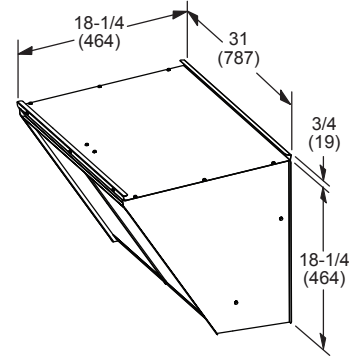

OUTDOOR AIR DAMPER HOOD DETAIL (Downflow or Horizontal Applications)

MANUAL OUTDOOR AIR DAMPER HOOD

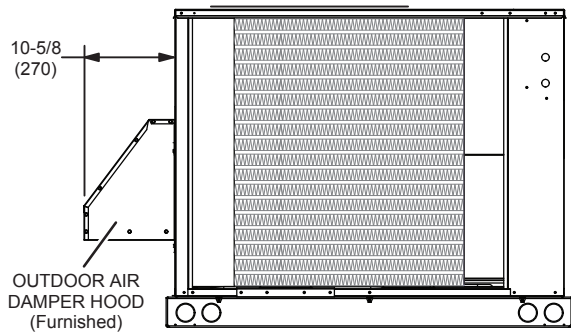

END VIEW

MOTORIZED OUTDOOR AIR DAMPER HOOD

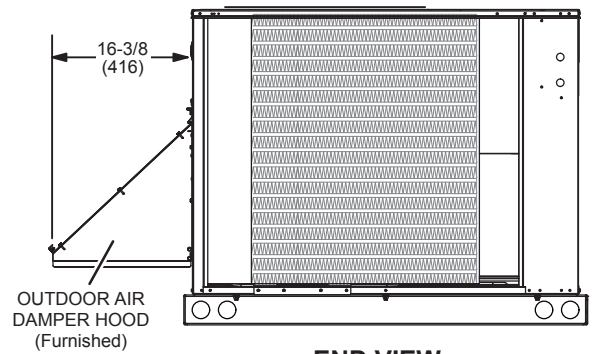

END VIEW

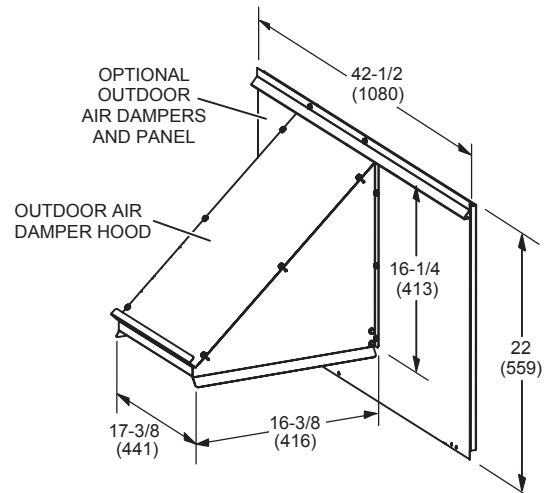
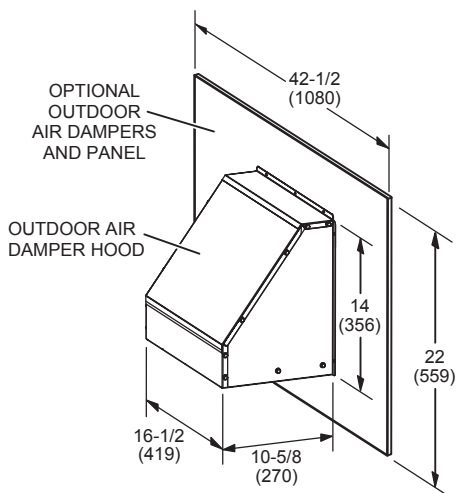

**OUTDOOR AIR HOOD DETAIL WITH OPTIONAL ECONOMIZER AND BAROMETRIC RELIEF DAMPERS
(Horizontal Applications)**

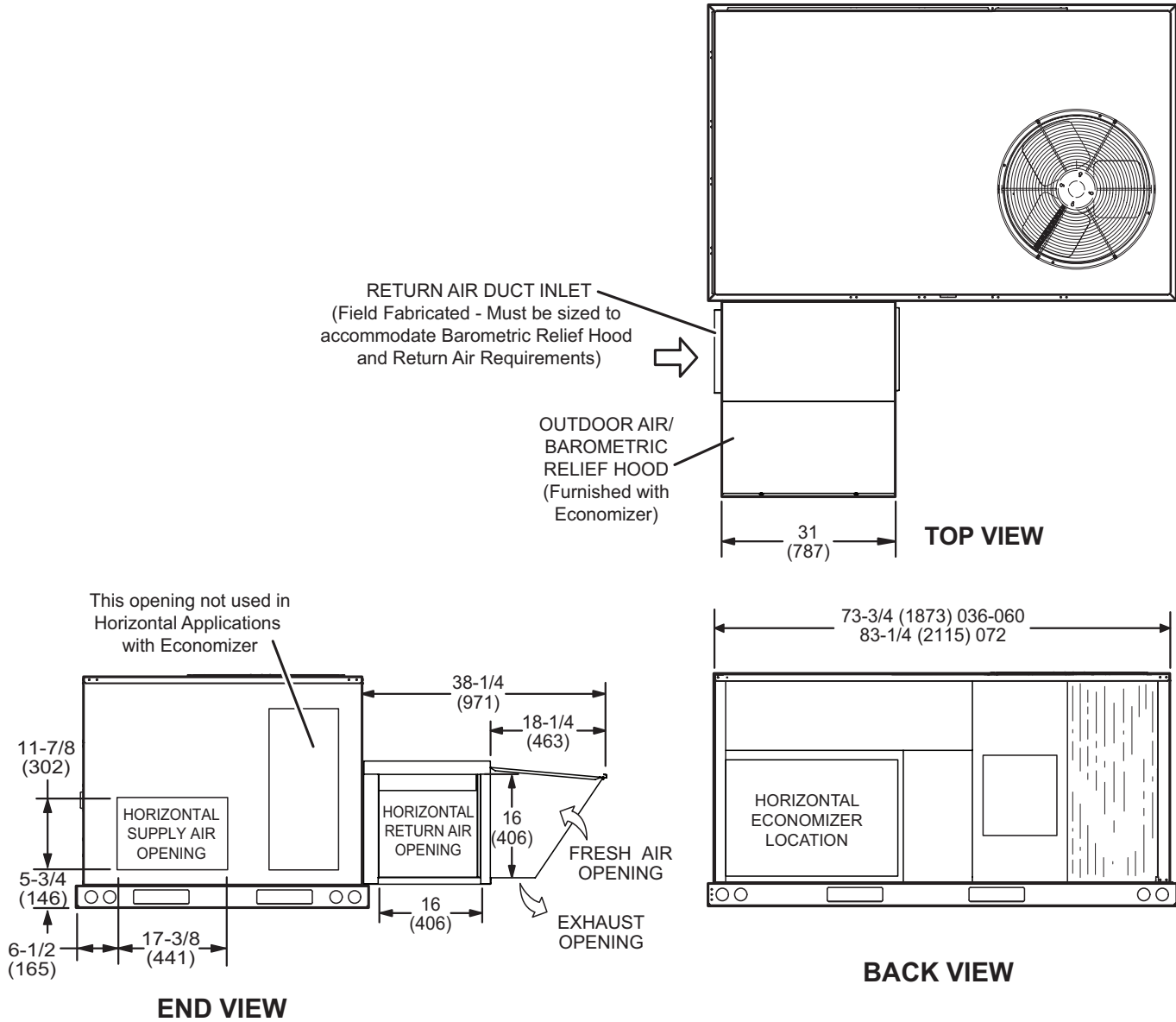

Note - Return Air Duct and Transition must be supported.

DIMENSIONS - ACCESSORIES

HYBRID ROOF CURBS - DOUBLE DUCT OPENING

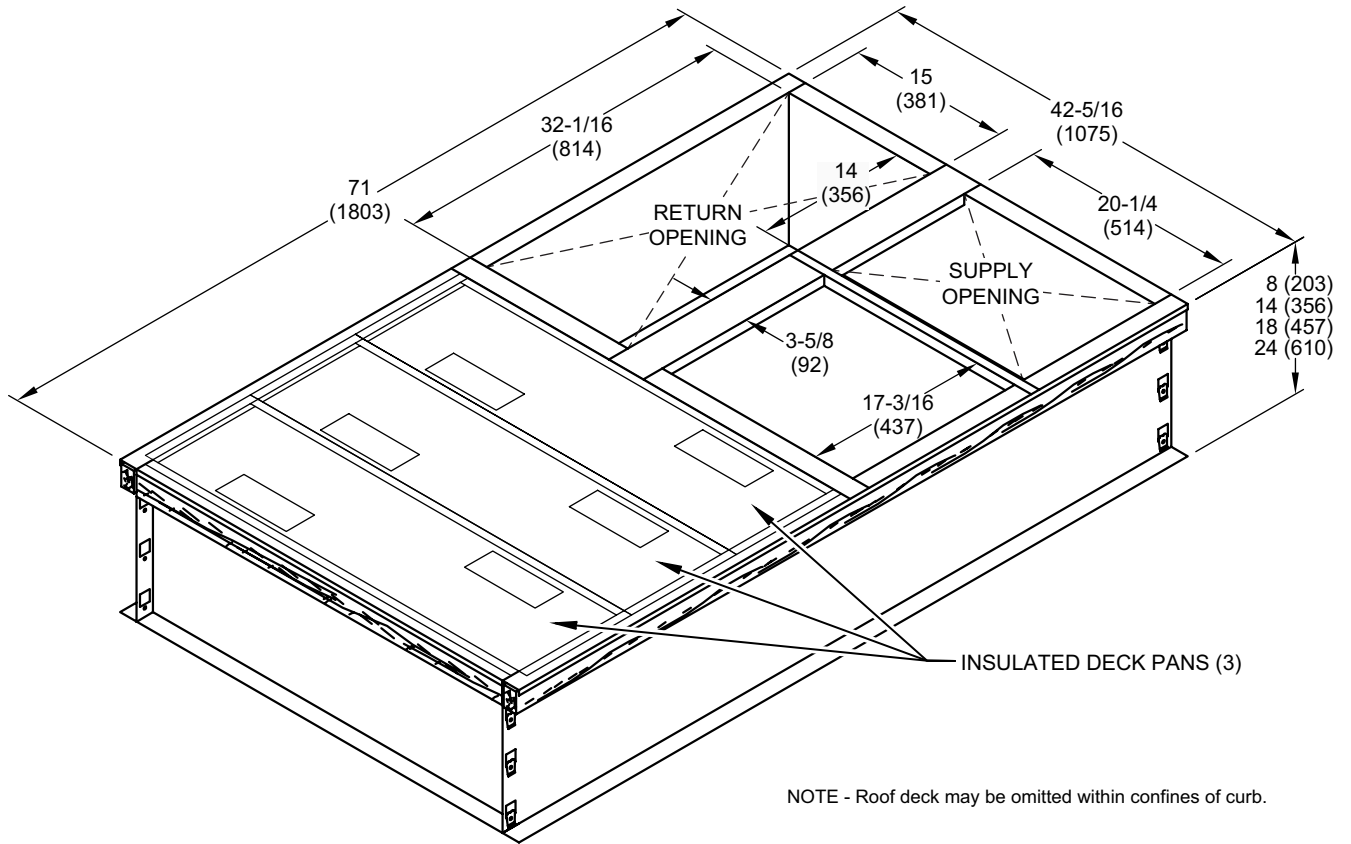

TYPICAL FLASHING DETAIL FOR ROOF CURB

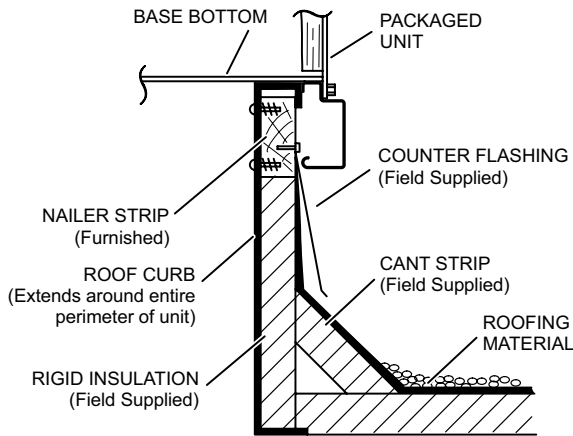

DETAIL ROOF CURB

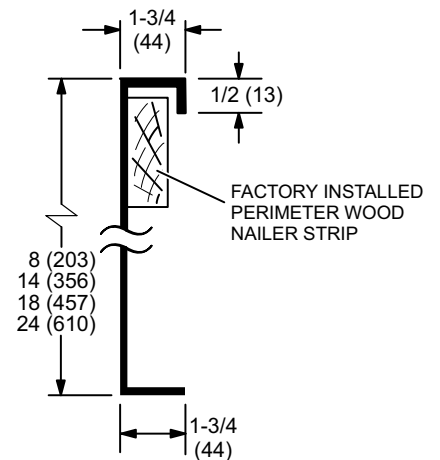

DIMENSIONS - ACCESSORIES

COMBINATION CEILING SUPPLY AND RETURN DIFFUSERS

STEP-DOWN CEILING DIFFUSER

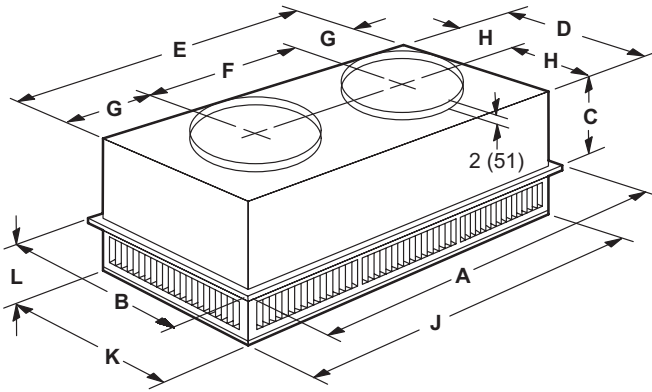

FLUSH CEILING DIFFUSER

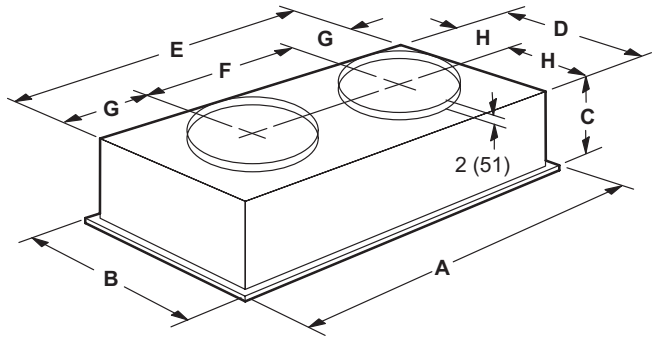

Model Number		RTD9-65S	RTD11-95S
A	in.	47-5/8	47-5/8
	mm	1159	1159
B	in.	23-5/8	29-5/8
	mm	600	752
C	in.	11-3/8	14-3/8
	mm	289	365
D	in.	21-1/2	27-1/2
	mm	546	699
E	in.	45-1/2	45-1/2
	mm	1156	1158
F	in.	22-1/2	22-1/2
	mm	572	572
G	in.	11-1/2	11-1/2
	mm	292	292
H	in.	10-3/4	13-3/4
	mm	273	349
J	in.	45-1/2	45-1/2
	mm	1156	1156
K	in.	21-1/2	27-1/2
	mm	546	699
L	in.	7-1/8	8-1/8
	mm	181	206
Duct Size	in.	18 round	20 round
	mm	457 round	508 round

Model Number		FD9-65S	FD11-95S
A	in.	47-5/8	47-5/8
	mm	1159	1159
B	in.	23-5/8	29-5/8
	mm	600	752
C	in.	13-1/2	16-5/8
	mm	343	422
D	in.	21	27
	mm	533	686
E	in.	45	45
	mm	1143	1143
F	in.	22-1/2	22-1/2
	mm	572	572
G	in.	11-1/4	11-1/4
	mm	286	286
H	in.	10-1/2	13-1/2
	mm	267	343
Duct Size	in.	18 round	20 round
	mm	457 round	508 round



Visit us at www.lennox.com
For the latest technical information, www.lennoxcommercial.com
Contact us at 1-800-4-LENNOX

NOTE - Due to Lennox' ongoing commitment to quality, Specifications, Ratings and Dimensions subject to change without notice and without incurring liability. Improper installation, adjustment, alteration, service or maintenance can cause property damage or personal injury. Installation and service must be performed by a qualified installer and servicing agency.

©2021 Lennox Industries, Inc.