



SUBMITTAL DATA - CEILING CASSETTE

M22A012S4-2P

MULTI-ZONE MINI-SPLIT HEAT PUMP

Job: _____
Location: _____
Schedule No.: _____
System Designation: _____

Engineer: _____
Architect: _____
Date: _____
For: Reference Approval Review Construction

FEATURES

- Pre Heat Function
- Auto Restart
- 360° Airflow Panel
- Built-In Condensate Pump
- Flare Connections
- LED Readout Panel
- Refrigerant R-410A
- Wireless Remote Controller included

Product Warranty

All covered components - Twelve year limited warranty.
 Product registration required.

SPECIFICATIONS

PERFORMANCE

Cooling Capacity ¹ (Btu/h)		12,000
Heating Capacity ¹ (Btu/h)		12,000
Airflow (CFM)	High	400
	Medium	340
	Low	280
External Static Pressure (in. w.g.)		-
Sound Pressure (dBA)	High	41
	Medium	38
	Low	35

ELECTRICAL DATA

Power Supply (V/Hz/Φ)	208-230/60/1
Rated load amps (RLA)	1.0
Power Output (W)	46

DIMENSIONS

Unit Dimensions (in)	Height	10-3/8
	Width	22-1/2
	Depth	22-1/2
Liquid Pipe Connection (in)		1/4
Gas Pipe Connection (in)		1/2
Condensate drain connection (in)		1
Unit Shipping Weight (lb)		42
Unit Net Weight (lb)		36



OPTIONAL ACCESSORIES

Non-Programmable Controller (M0STAT61Q-1):	
Wireless Remote Controller (M0STAT60Q-1):	1+
Programmable Controller (M0STAT64Q-1):	

NOTES

- Cooling and Heating capacity data is rated at the following conditions:
 Cooling: 80°FDB / 67°FWB Indoor, 95°FDB Outdoor
 Heating: 70°FDB Indoor, 47°FDB / 43°FWB Outdoor
- Cassette Panel (M0STAT62Q-1) ordered separately.



NOTE - Due to Lennox' ongoing commitment to quality, Specifications, Ratings and Dimensions subject to change without notice and without incurring liability. Improper installation, adjustment, alteration, service or maintenance can cause property damage or personal injury. Installation and service must be performed by a qualified installer and servicing agency.



SUBMITTAL DATA - **CEILING CASSETTE**

M22A012S4-2P

MULTI-ZONE MINI-SPLIT HEAT PUMP

DIMENSIONAL DRAWINGS - INCHES (MM)

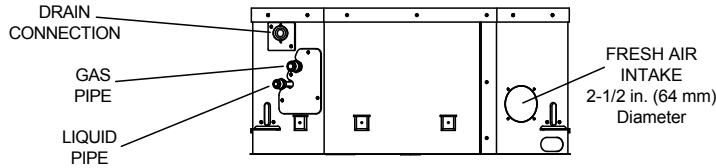

SIDE VIEW

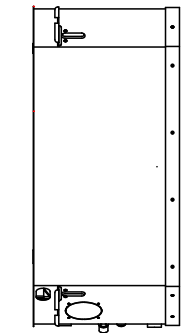

LEFT SIDE VIEW

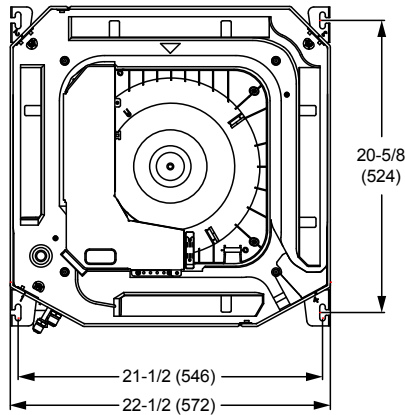

BOTTOM VIEW (Body)

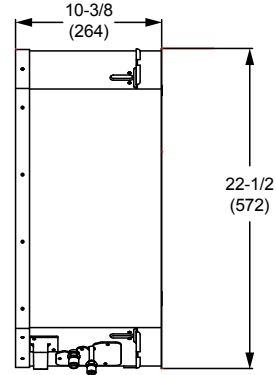

RIGHT SIDE VIEW

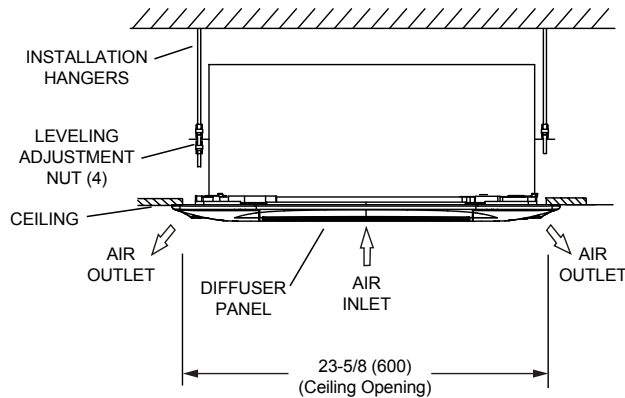

SIDE VIEW

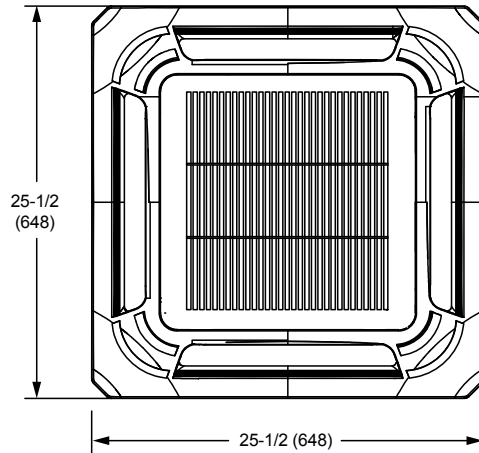

BOTTOM VIEW (Panel)

NOTE - Due to Lennox' ongoing commitment to quality, Specifications, Ratings and Dimensions subject to change without notice and without incurring liability. Improper installation, adjustment, alteration, service or maintenance can cause property damage or personal injury. Installation and service must be performed by a qualified installer and servicing agency.