



SUBMITTAL DATA – **DUCTED**
MPB018S4S-1P – MMDB018S4-2P
 SINGLE ZONE MINI-SPLIT HEAT PUMP

Job: _____
Location: _____
Schedule No.: _____
System Designation: _____

Engineer: _____
Architect: _____
Date: _____
For: Reference Approval Review Construction

FEATURES

Outdoor Unit: MPB018S4S-1P



- DC Inverter Control
- Base Panel Heater
- Defrost Control
- Low Ambient Cooling/Heating

Indoor Unit: MMDB018S4-2P

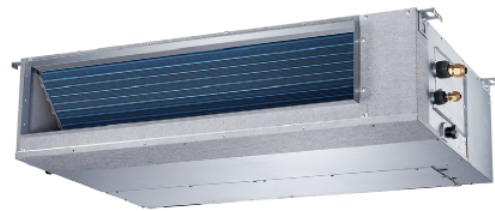

- Auxiliary Heat Function
- Auto Restart
- Built-in Condensate Dump
- Three Selectable Fan Speeds
- Flare Connections
- LED Floodlight Panel
- Wired Remote Controller Included

PIPING

Line Set and Elevation Guidelines

Maximum Line Set Length ft. (m)	98 ft. (30 m)
Maximum Elevation - Outdoor Unit Below/Above Indoor Unit ft. (m)	66 ft. (20m)
Liquid Line Set Diameter (in.)	1/4
Gas Line Set Diameter (in.)	1/2
Pre-Charged (ft.)	25
Additional Charge of Refrigerant (oz/ft.)	0.161

PRODUCT WARRANTY

Compressor – Twelve year limited warranty*
 All other covered components - Twelve year limited warranty*
 *Product registration required

OPTIONAL ACCESSORIES

Hail Guards (M9GARD15Q-1)
 Programmable Controller (M0STAT64Q-1)



NOTE – Due to Lennox' ongoing commitment to quality, Specifications, Ratings, and Dimensions are subject to change without notice and without incurring liability. Improper installation, adjustment, alteration, service or maintenance can cause property damage or personal injury. Installation and service must be performed by a qualified installer and servicing agency.



SUBMITTAL DATA - DUCTED
MPB018S4S-1P – MMDB018S4-2P
 SINGLE ZONE MINI-SPLIT HEAT PUMP

OUTDOOR SPECIFICATIONS

PERFORMANCE	
Cooling Capacity (Btu/h) ¹	18,000
EER	12.5
SEER	19.0
Heating Capacity (Btu/h) ¹	18,000
HSPF	10.5
Outdoor Fan Total Air Volume (CFM)	1,200
Ambient Temperature Operating Range	
Cooling	-13°F - 122°F
Heating	-13°F - 86°F
ELECTRICAL DATA	
Power Supply (V/Hz/Φ)	208-230/60/1
Minimum Circuit Ampacity (A)	15
Maximum Overcurrent Protection (A)	20
Outdoor Fan Motor RLA (A)	0.6
Compressor RLA (A)	10.5
No. of Compressors	1

GENERAL DATA	
Connection Ratio (%)	100%
Max. # of Indoor Units	1 unit
Sound Data (dBA) - Cooling/Heating	60/60
Refrigerant type	R-410A
Factory refrigerant charge	4 lbs. 5 oz.
DIMENSIONS	
Unit Dimensions (in)	Height 27-1/2
	Width 33-1/4
	Depth 13
Shipping Weight (lb)	113
Net Weight (lb)	107

NOTES

1. Cooling and Heating Capacity data is rated at the following conditions:
 Cooling: 80°FDB / 67°FWB Indoor, 95°FDB Outdoor
 Heating: 70°FDB Indoor, 47°FDB / 43°FWB Outdoor

OUTDOOR DIMENSIONAL DRAWINGS - INCHES (MM)

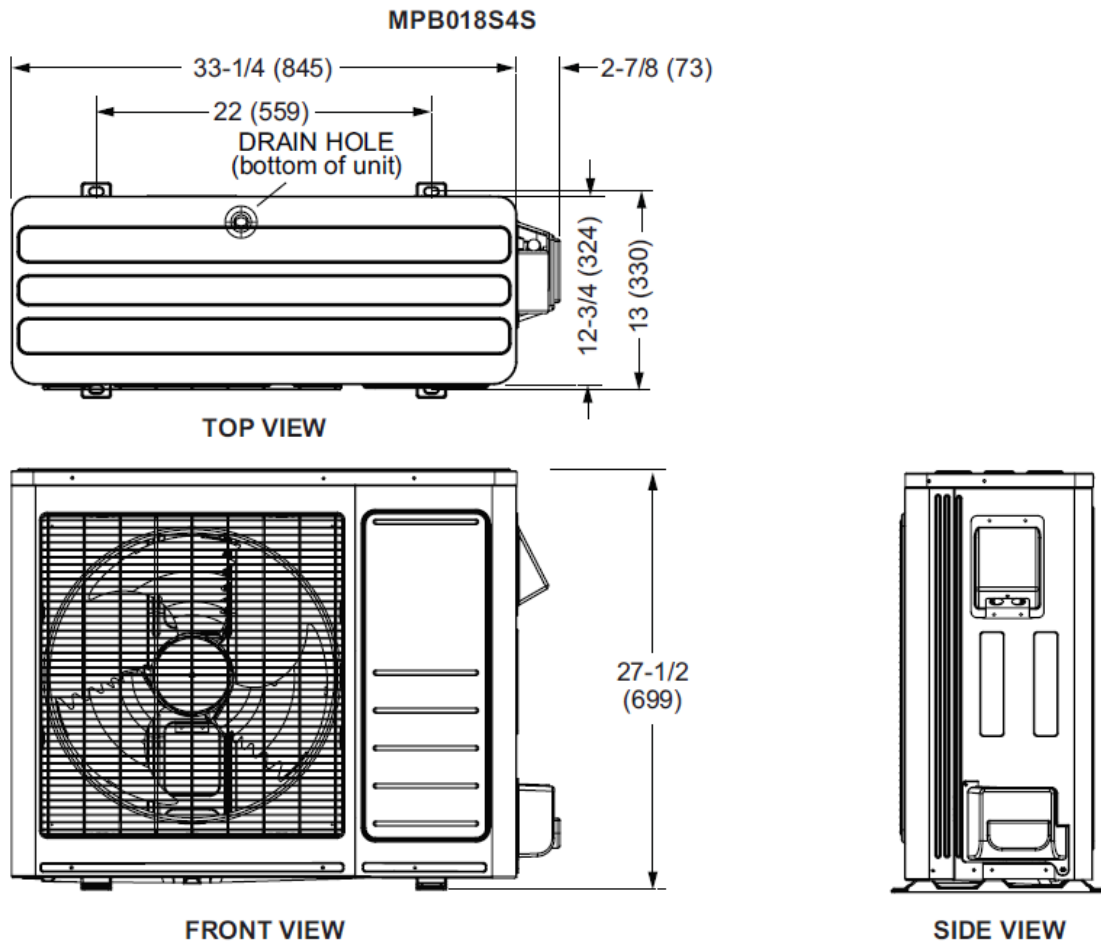

NOTE – Due to Lennox’ ongoing commitment to quality, Specifications, Ratings, and Dimensions are subject to change without notice and without incurring liability. Improper installation, adjustment, alteration, service or maintenance can cause property damage or personal injury. Installation and service must be performed by a qualified installer and servicing agency.



SUBMITTAL DATA - **DUCTED**

MPB018S4S-1P – MMDB018S4-2P

SINGLE ZONE MINI-SPLIT HEAT PUMP

INDOOR SPECIFICATIONS

PERFORMANCE

Airflow (CFM)	High	505
	Medium	430
	Low	350
External Static Pressure (in. w.g.)		0 - 0.40
Sound Pressure (dBA)	High	39
	Medium	37
	Low	35

ELECTRICAL DATA

Power Supply (V/Hz/Φ)	Supplied by ODU
Rated load amps (RLA)	1.2
Power Output (W)	160

DIMENSIONS

Unit Dimensions (in)	Height	8-1/4
	Width	37-7/8
	Depth	26-1/2

Unit Net/Shipping Weight (lb)	54/66
-------------------------------	-------

PIPING

Liquid/Gas O.D. Flare (in.)	1/4 , 1/2
Drain Connection O.D. (in.)	1

WIRED REMOTE CONTROLLER SPECIFICATIONS

M0STAT61Q-1

Input Voltage (V)	5Vdc
Communication Cabling	Factory 4-wire harness
Operating Temperature Range	23°F to 110°F
Operating Humidity Range (RH)	40% ~ 90%
Setpoint Range	62°F ~ 86°F

DISPLAY

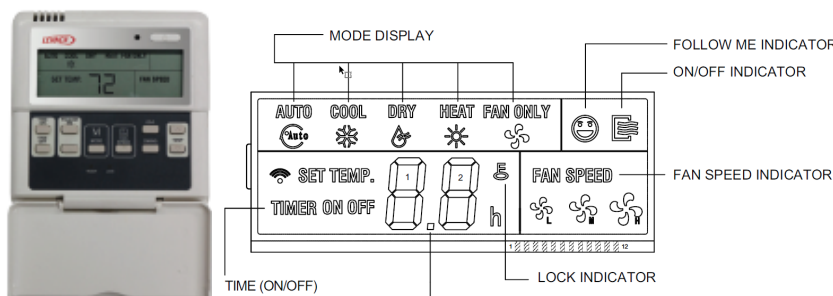

INDOOR DIMENSIONAL DRAWINGS - INCHES (MM)

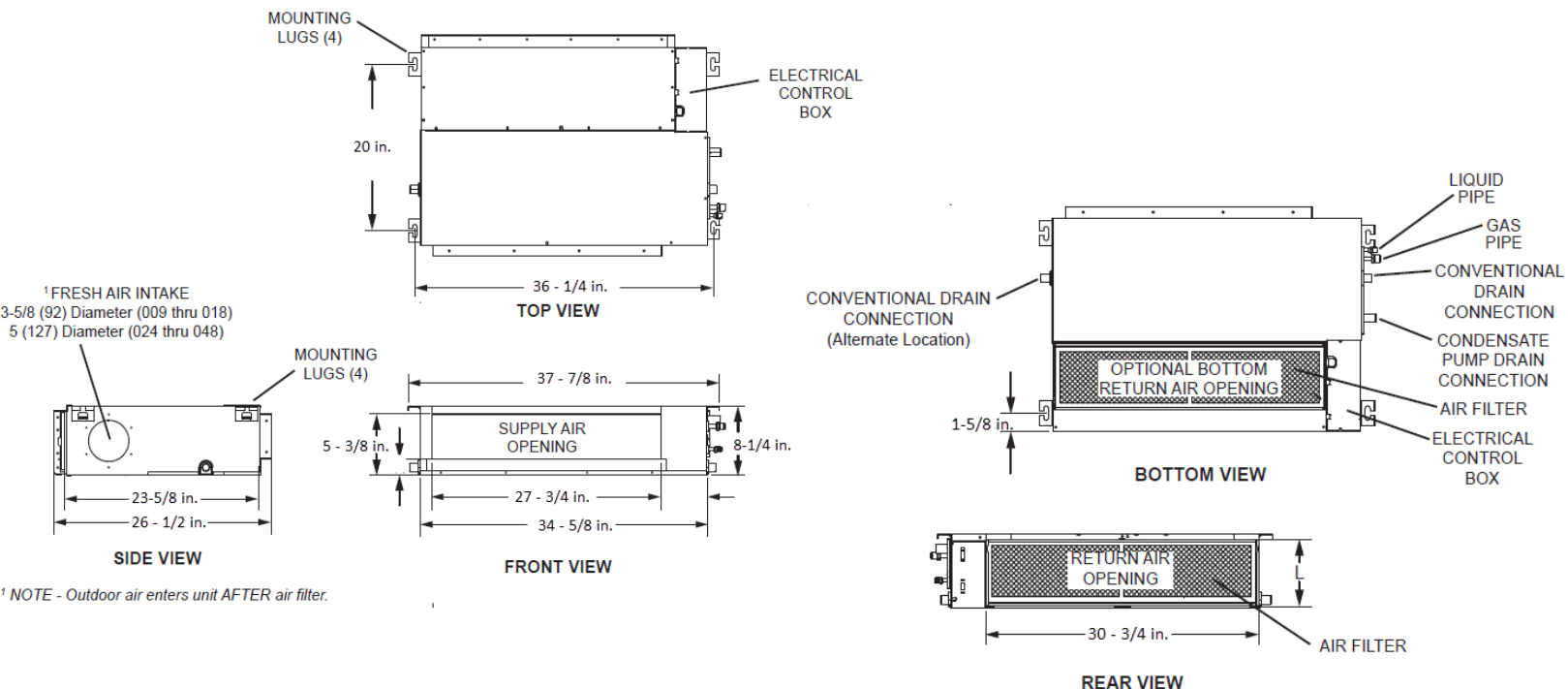

¹ NOTE - Outdoor air enters unit AFTER air filter.

NOTE – Due to Lennox' ongoing commitment to quality, Specifications, Ratings, and Dimensions are subject to change without notice and without incurring liability. Improper installation, adjustment, alteration, service or maintenance can cause property damage or personal injury. Installation and service must be performed by a qualified installer and servicing agency.