

Job: _____
 Location: _____
 Schedule No.: _____
 System Designation: _____

Engineer: _____
 Architect: _____
 Location: _____
 Date: _____

Heat Pump Outdoor Unit

For: Reference Approval Review Construction

FEATURES

- Two-pipe heat pump
- High efficiency twin toary compressor
- Intelligent soft start
- Built-in base pan heater
- Power meter interface

WARRANTY

- Compressor - 10-year limited warranty
 - All other components - 10-year limited warranty
- *See warranty for details

SPECIFICATIONS

PERFORMANCE

Cooling Capacity ¹ (Btu/h)	Nominal	36,000
	Rated ²	36,000
EER	Ducted	11.9
	Non-Ducted	12.1
SEER	Ducted	17.8
	Non-Ducted	19.2
Heating Capacity ¹ (Btu/h)		40,000
	HSPF	
	Ducted	10.4
	Non-Ducted	11.4

ELECTRICAL DATA

Power Supply (Volts/Phase/Hertz)	208-230/1/60
Minimum Circuit Ampacity (A)	36
Maximum Overcurrent Protection (A)	60
Compressor RLA (A)	26.5
Number of Compressors	1
Outdoor Fan Power Output (W)	90+90
Outdoor Fan FLA (A)	1.2/1.2

GENERAL DATA

Connection Ratio	45% to 130%
Maximum Number of Indoor Units	5
Outdoor Fan Total Air Volume (cfm)	4100
Sound Pressure Level (dBA)	61
Refrigerant Type	R-410A
Factory Refrigerant Charge (each unit)	8.6 lbs.

NOTES

1. Cooling and Heating capacity data is rated at the following conditions:
 Cooling: 80°FDB / 67°FWB Indoor, 95°FDB Outdoor
 Heating: 70°FDB Indoor, 47°FDB / 43°FWB Outdoor
2. Complies with AHRI 210/240 testing standards
3. Operating Voltage Range 191V to 247V



DIMENSIONS

Unit	Height	52-1/4
Dimensions (in)	Width	35-3/8
	Depth	13-1/4

Main System Piping (in)

Liquid Pipe Connection	3/8
Gas Pipe Connection	3/4
Unit Net Weight (lb)	220
Unit Shipping Weight (lb.)	245





VRF

SUBMITTAL DATA - OUTDOOR UNIT

VPB036H4M-3P

Mini-VRF Heat Pump

DIMENSIONAL DRAWINGS - INCHES (MM)

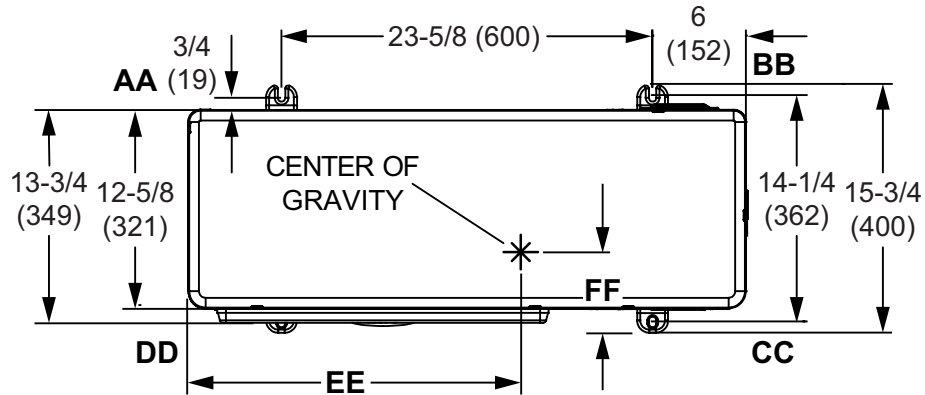

TOP VIEW

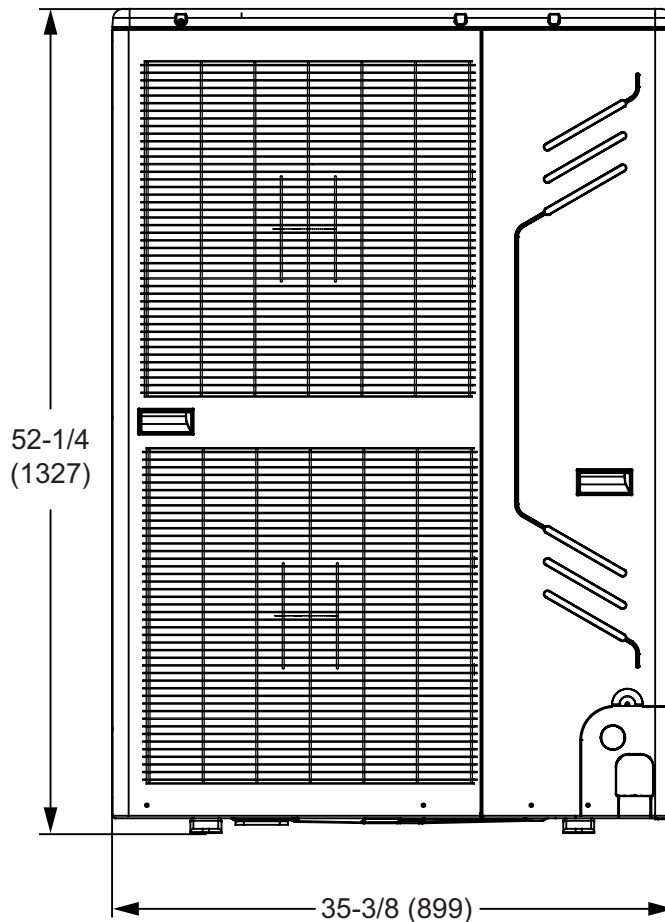

FRONT VIEW

NOTE - Due to Lennox' ongoing commitment to quality, Specifications, Ratings and Dimensions subject to change without notice and without incurring liability. Improper installation, adjustment, alteration, service or maintenance can cause property damage or personal injury. Installation and service must be performed by a qualified installer and servicing agency.

495828 (201911)

©2019 Lennox Industries Inc.