

Job: _____
 Location: _____
 Schedule No.: _____
 System Designation: _____

Engineer: _____
 Architect: _____
 Location: _____
 Date: _____

For: Reference Approval Review Construction

Heat Recovery Outdoor Unit

FEATURES

- Split coil heat exchanger
- Dual hinged electrical boxes for ease of maintenance
- High-efficiency vapor injection inverter compressors
- Intelligent Duty Cycle operation
- Night Silent operation
- Hinged service doors
- Built-in service console
- Built-in base pan heater
- Low Ambient Cooling

WARRANTY

- Compressor - 10-year limited warranty
 - All other components - 10-year limited warranty
- *See warranty for details

SPECIFICATIONS

PERFORMANCE

Cooling Capacity ¹ (Btu/h)	Nominal	192,000
	Rated ²	184,000
EER	Ducted	11.2
	Non-Ducted	10.9
IEER	Ducted	21.3
	Non-Ducted	21.2
Simultaneous Heating and Cooling Efficiency (SCHE)	Ducted	29.5
	Non-Ducted	30.7
Heating Capacity ¹ (Btu/h)		206,000
	COP47	
	Ducted	3.32
	Non-Ducted	3.25
COP17	Ducted	2.28
	Non-Ducted	2.25

ELECTRICAL DATA

Power Supply (Volts/Phase/Hz)	208-230/3/60
Minimum Circuit Ampacity (A)	85.4
Maximum Overcurrent Protection (A)	90
Compressor RLA (A)	34.5/34
Number of Compressors	2
Outdoor Fan Power Input (W)	1200/1200
Outdoor Fan FLA (A)	4.0/4.3

GENERAL DATA

Connection Ratio	50% to 130%
Maximum Number of Indoor Units	35
Refrigerant Type	R-410A
Factory Refrigerant Charge (each unit)	23.8 lbs.

NOTES

1. Cooling and Heating capacity data is rated at the following conditions:
 Cooling: 80°FDB / 67°FWB Indoor, 95°FDB Outdoor
 Heating: 70°FDB Indoor, 47°FDB / 43°FWB Outdoor
2. Complies with AHRI 1230-2014 testing standards
3. Operating Voltage Range 175V to 263V
4. To achieve cooling lower than 5°F a Low ambient hood must be installed. This is purchased as an accessory.
5. A local 115V power outlet is available as an accessory to provide local power for maintenance.



DIMENSIONS

Unit	Height	72
Dimensions (in)	Width	68-1/2
	Depth	32-5/8

Main System Piping (in)

Liquid Pipe Connection	3/4
High Pressure Gas Pipe	1-3/8
Low Pressure Gas Pipe	1-3/8

Balancing Pipework between Modules (in)

Gas Balance Pipe Connection	3/4
Oil Balance Pipe Connection	1/4
Unit Net Weight (lb)	1118



NOTE - Due to Lennox' ongoing commitment to quality, Specifications, Ratings and Dimensions subject to change without notice and without incurring liability. Improper installation, adjustment, alteration, service or maintenance can cause property damage or personal injury. Installation and service must be performed by a qualified installer and servicing agency.

DIMENSIONAL DRAWINGS - INCHES (MM)

CORNER WEIGHTS								CENTER OF GRAVITY			
AA		BB		CC		DD		EE		FF	
lbs.	kg	lbs.	kg	lbs.	kg	lbs.	kg	in.	mm	in.	mm
172	78	264	120	330	150	321	146	37-3/4	953	12	305

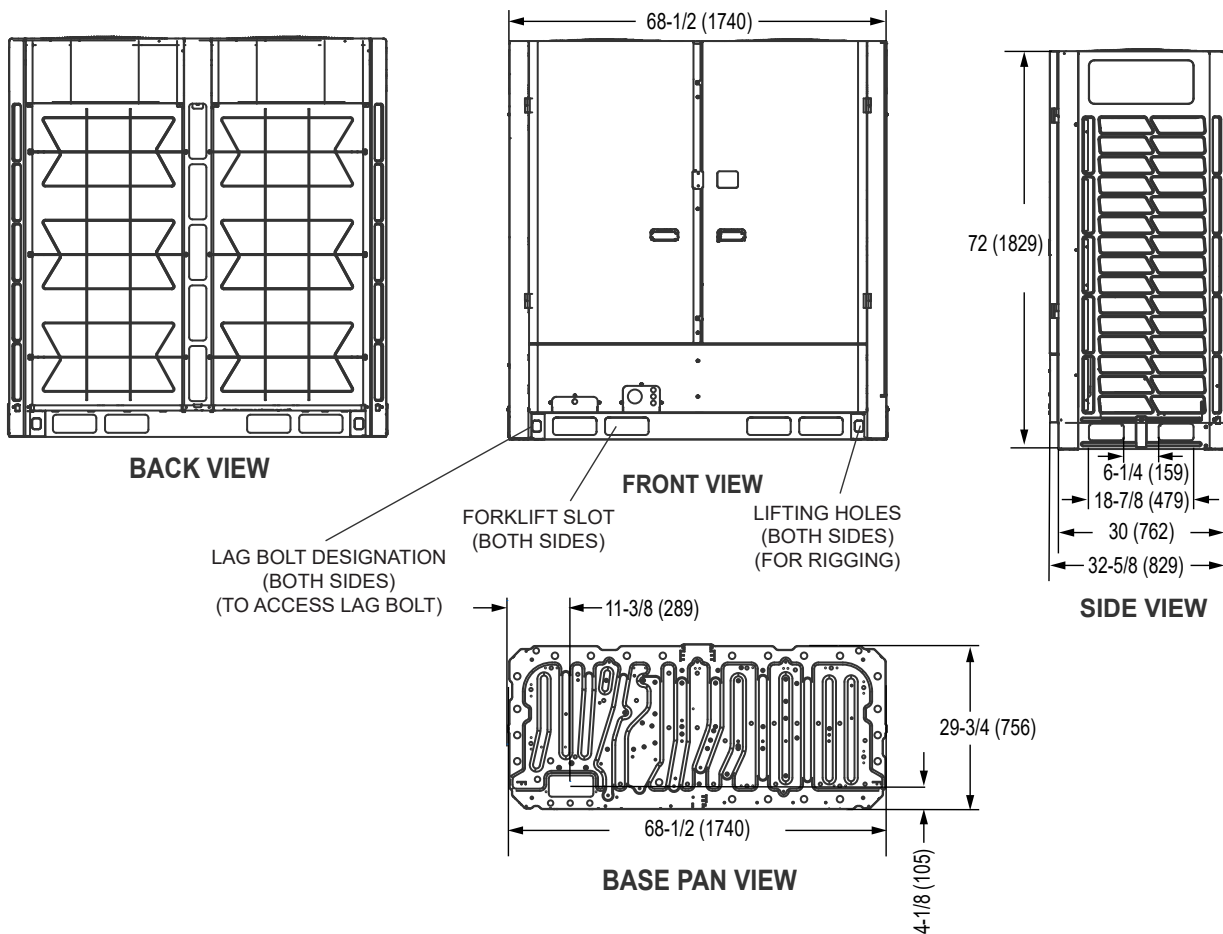
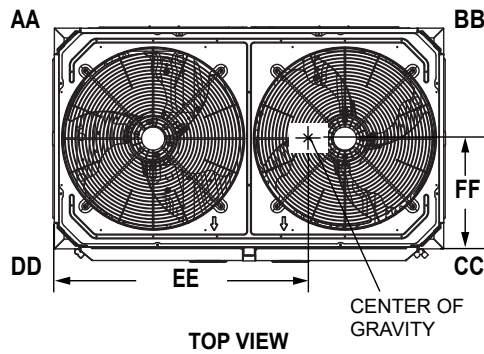

NOTE - Due to Lennox' ongoing commitment to quality, Specifications, Ratings and Dimensions subject to change without notice and without incurring liability. Improper installation, adjustment, alteration, service or maintenance can cause property damage or personal injury. Installation and service must be performed by a qualified installer and servicing agency.