

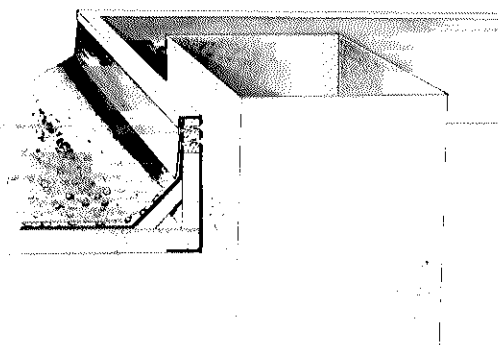

**SINGLE PACKAGE HEAT PUMPS
CHP8-511-513 AND CHP8-651-653
HORIZONTAL AND DOWN-FLO**

***48,000 to 59,000 Btuh Total Cooling Capacity**
***48,000 to 62,000 Btuh Total Heating Capacity**
21,000 to 112,500 Btuh Optional Electric Heat

*ARI Certified Ratings

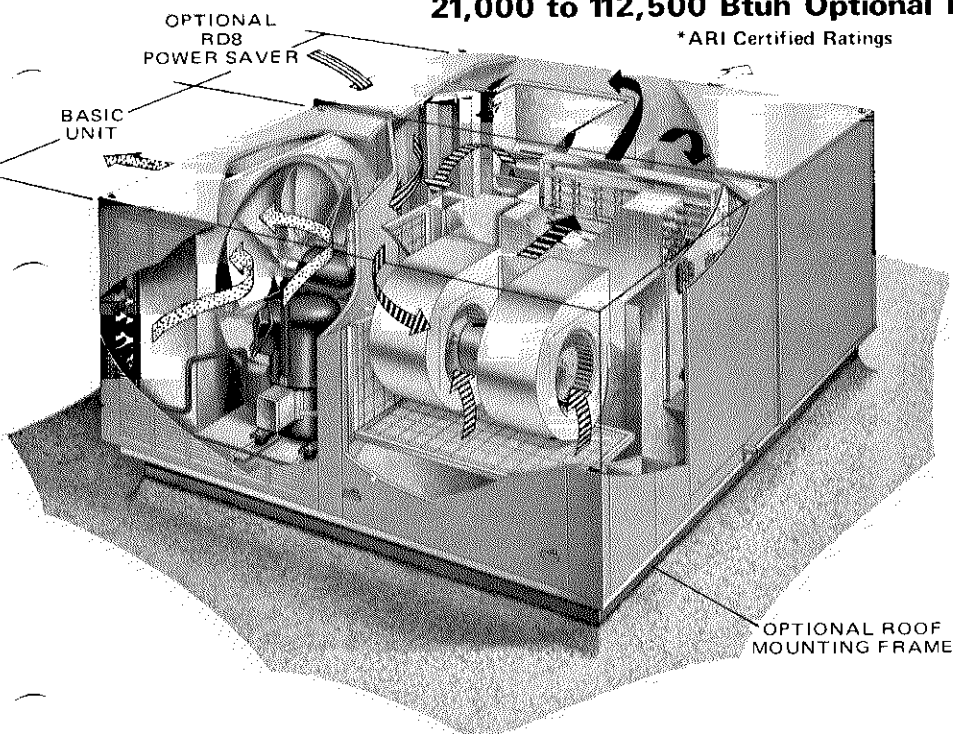

Optional Roof Mounting Frame Detail

Weatherproof frame (RMF3-65) is used whenever RT8 duct enclosure or RD8 POWER SAVER T.M. is used. The frame extends around the entire perimeter of the CHP8 and RT8 or RD8. Duct connection and entry into the conditioned area are accomplished within the confines of the frame.

CHP8-651-653
(With optional POWER SAVER T.M., electric heat and roof mounting frame)

Installation Flexibility Featured in Single Package Heat Pump Unit

The CHP8 series heat pump units are designed primarily for rooftop installation with the RT8 duct enclosure or RD8 POWER SAVER and RMF3 roof mounting frame. The separate roof frame mates to the bottom of the CHP8 and RT8 or RD8 and when flashed into the roof permits weatherproof duct connection and entry into the conditioned area. No additional roof curbing or flashing is required. The assembled CHP8 and RT8 or RD8 are easily hoisted to rooftop level by lifting lugs factory installed on the equipment. The single package unit can also be installed on a slab at grade level with end handling of conditioned air. The insulated single cabinet houses highly efficient air cooled DX cooling, power-

ful direct drive blowers, air filters and optional electric heat. Complete factory sealed refrigeration system consists of compressor, indoor coil and twin blowers, outdoor coil and fan, reversing valve, refrigerant drier, refrigerant lines connected and a full charge of refrigerant. Controls consist of high and low pressure switches, de-frost control, compressor relay and overload protection. Optional POWER SAVER (RD8) and controls reduce cooling costs. Externally mounted fresh air damper (manual) is also available. A heating-cooling thermostat is furnished. Units are shipped completely assembled, wired and piped ready to install. Installer has only to set unit, connect ductwork, power supply and thermostat field wiring connections.

Typical Applications

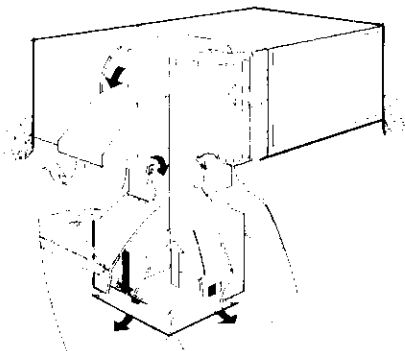

Combination ceiling supply and return air application. Step-down or flush diffuser available.

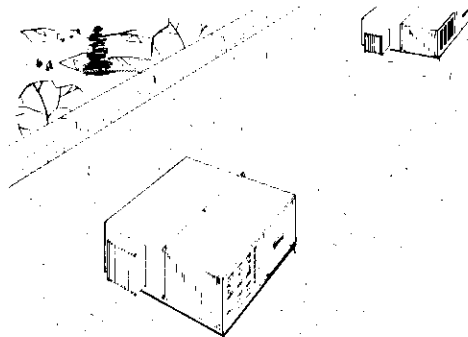

Rooftop installation with optional RD8 POWER SAVER. Use of optional RD8 POWER SAVER or RT8 duct enclosure allows bottom handling of conditioned air.

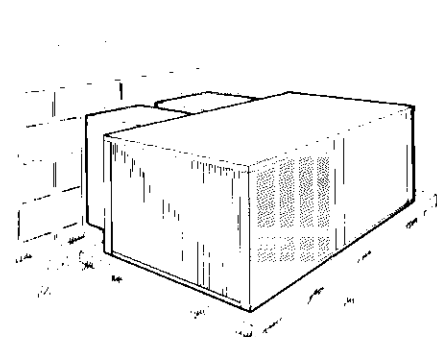

Basic unit on a slab at grade level with end delivery of conditioned air.

NOTE: Specifications, ratings and dimensions subject to change without notice.

Thoroughly Tested and Approved—Heat pump system has been completely tested in the Lennox environmental test room and accurately rated according to ARI Standard 240 conditions. In addition unit has been sound tested in the Lennox reverberant sound test room and rated according to ARI Standard 270 conditions. Units coming within the scope of this standard (135,000 Btuh or less) carry the ARI certification seal. Heat pump equipment and optional electric heat are U.L. Listed. Units and components within are bonded for grounding to meet safety standards for servicing required by U.L. and NEC. Units are test operated at the factory before shipment.

Dependable Compressor—Resiliently mounted in unit and the running gear assembly is spring mounted within the sealed can. It is suction cooled and equipped with suction and discharge pressure test ports. Overload protected and equipped with effective slugging protection.

Lennox Coils—Extra large coils (indoor and outdoor) are constructed of ripple-edge aluminum fins machine "flat" fitted to seamless copper tubes. This provides more contact area and excellent heat transfer. Coils are pressure leak tested at 450 to 500 psi.

Rugged Cabinet—Heavy gauge galvanized hot dipped steel cabinet panels. A five station wash metal preparation assures a perfect bonding surface for the finish coat of baked-on enamel. Large removable panels provide complete service access to interior of cabinet.

Thick Interior Insulation—All of the interior panels where conditioned air is handled are lined with thick fiberglass insulation. This results in quiet and efficient operation due to the excellent acoustical and insulating qualities of fiberglass. In addition the entire bottom of unit is insulated with thick fiberglass insulation.

Efficient Outdoor Fan—Direct drive axial flow fan moves large air volumes through the entire outdoor coil resulting in high refrigerant cooling capacity. Air enters unit through louvered panel and is discharged through coil at side of unit. An optional top exhaust hood is available for top discharge of outdoor coil air. Order No. BM-4186.

Powerful Blowers—Twin direct drive blowers deliver large air volumes with low power consumption. Equipped with a transformer speed controller giving a choice of three blower speeds, high-medium-low.

Cleanable Air Filter—One inch frame filters are furnished as standard. Media is washable or vacuum cleanable polyurethane. It is easily accessible for cleaning and is coated with oil for increased efficiency. Use RP products filter coating No. 418 when reoilng.

Defrost Control—A clock timer defrost control is furnished as standard equipment. It gives a defrost cycle (if needed) for every 90 minutes of on time. A sensing element on the outdoor coil determines when the defrost cycle is required and also when to terminate a cycle.

Thermostat—A deluxe wall mounted heating-cooling (two-stage heat-single stage cool) thermostat is furnished as standard. It is equipped with a system selector switch, blower switch for automatic or continuous operation and built in heat and cool anticipation. The four separate mercury bulbs control cooling cycle, first stage heating (heat pump), second stage heating (electric heat) and reversing valve operation. An optional emergency heat thermostat sub-base (P-8-8893) is available and must be ordered extra. Sub-base permits auxiliary electric heat only to operate in case of compressor malfunction.

Mounting Frame (Optional)—The RMF3-65 mounting frame is available for mounting the RT8 or RD8 duct enclosure and CHP8 unit. Frame provides an automatic weather sealed rooftop installation. Approved by National Roofing Contractors Association. A securing bolt kit (BM-6909), containing bolts to secure unit to frame, is available and must be ordered extra.

Electric Heat (Optional)—Available for field installation in 9.4 thru 33.0 kw sizes. See electric heat table. The heating elements are helix wound Nichrome wire exposed to the air stream resulting in rapid heat transfer, lower coil temperatures and a long life. The elements are accurately located and insulated from the plated supporting frame by high quality insulators.

Outdoor Thermostat (Optional)—Maintains heating load on the heat pump as long as possible before allowing the optional auxiliary heat to come on the line. Order number M-1595 thermostat box and P-8-3261 outdoor thermostat. See bulletin (Page 19) in Accessory section.

Mild Weather Control (Optional)—Allows heating operation of unit during mild weather when heating cycle is required. Order number M-2374.

Low Temperature Kit (Optional)—Consists of remote bulb thermostat and thermostat box. Order number BM-6773. Mounts exterior to the unit and prevents compressor operation below 15°F. A crankcase heater is required on the compressor and must be ordered in addition to the kit. Order number P-8-7160.

Supply and Return Duct (Optional)—Provides connection of combination supply and return diffuser. Furnished in nominal 4 ft. lengths and constructed of 1" thick fiberglass duct board with an aluminum exterior. Shipped knocked down with the tape, staples and installing instructions for field assembly. See specification table for order no. and mounting detail drawing for dimensions.

Combination Supply and Return Diffusers (Optional)—Lennox offers two different styles of air diffusers. The RTD step down model extends below ceiling level when installed. The FD model is almost flush with the ceiling when installed. Supply air is discharged thru the outside grilles and return air enters thru the center grille on both models. Adjustable grilles are available, on both models, for air distribution.

Optional Minimum Fresh Air Damper—Externally mounted in RT8-65 duct enclosure. Equipped with manually operated damper and necessary fittings for installing.

Optional RD8 POWER SAVER And RT8 Duct Enclosure—Application flexibility is possible with the options available as follows:

- 1 Completely assembled RD8-65 Power Saver and Duct Enclosure:
 - A—With wired and linked Power Saver Installed.
 - a—With hole cut for combination ceiling supply and return distribution.
 - b With holes cut for distribution ducts.
 - 2 Completely assembled RT8-65 duct enclosure:
 - A—Without Power Saver (Power Saver cannot be added to RT8, if Power Saver is required order RD8-65)
 - a—With hole cut for combination ceiling supply and return distribution.
 - b—With holes cut for distribution ducts.

POWER SAVER Operation—The entire Power Saver control system is factory installed and wired, simply make plug-in connections to complete the job. The basic control system consists of:

1—**LENNOX DO-3-S-24** volt, spring return multi-position damper motor with motor and gear train sealed in non-temperature sensitive oil. It controls the position of the outdoor air, recirculated air and pressure relief dampers as dictated by the room thermostat and controlled by the following:

2—**Mixed Air Temperature Controller**—This adjustable highly sensitive device controls the damper motor to position the dampers to give the selected mixed air temperature. The inherent quick sensing of this control coupled with the fast acting Lennox damper motor gives in effect modulated control of the entering mixed air temperature.

3—**Compressor Monitor**—An outdoor thermostat switch (adjustable) which locks out compressor operation below approximately 58F outdoor air temperature. This allows the outdoor air to handle the entire cooling load below 58F.

4—**Outdoor Air Monitor**—A temperature sensing control (adjustable) which returns the outdoor air dampers to minimum when the outdoor air has more heat than recirculated room air, usually set at 70F.

5—**Climate Selection Switch**—A manually operated toggle switch with one position labeled "Dry Climate Maximum Power Saving" and the other labeled "Humid Climate—Maximum De-humidification." In the "Dry Climate" position, above the Compressor Monitor temperature setting (usually 58F) and below the Outdoor Air Monitor setting (usually 70F) the outdoor air damper can open 100% as dictated by the mixed air temperature controller. This provides the maximum "Free Cooling" benefits from the outdoor air. In the "Humid Climate" position above 58F and below 70F, the outdoor air damper can open 100% (controlled by mixed air temperature controller) only when the compressor is operating. This gives maximum dehumidification because in moist climates the humid outdoor air enters the structure in maximum quantity only when the compressor is operating, thus "drying out" the air.

6—**Room Thermostat**—The Lennox Power Saver will co-operate perfectly with the heating-cooling thermostat furnished. The thermostat commands the aforementioned heating, cooling, cooling with outdoor air and ventilation cycles.

SPECIFICATIONS

Model No.		CHP8-511-513	CHP8-651-653
††ARI Certified Cooling Capacity	Total capacity (Btuh)	48,000	59,000
	Total unit watts	7300	8300
	Dehumidifying capacity	22%	26%
††ARI Certified Heating Capacity	Total capacity (Btuh)	48,000	62,000
	Total unit watts	6100	7000
††ARI Certified Heating Application Capacity	Total capacity (Btuh)	28,000	37,000
	Total unit watts	5200	5600
Blower wheel nominal diam. x wid. (in.)		(2) 10 x 6	(2) 10 x 6
Blower motor hp.		1/2	1/2
Outdoor Coil	Net face area (sq ft)	6.95	8.33
	Tube diam. (in.) & No. of rows	1/2-3	1/2-3
	Fins per inch	13	13
Outdoor Coil Fan	Diam. (in.) & No. of blades	26-5	26-5
	Air volume (cfm)	4100	4320
	Motor hp	1/2	1/2
	Watts input	670	670
Indoor Coil	Net face area (sq ft)	3.75	4.58
	Tube diam. (in.) & No. of rows	1/2-4	1/2-4
	Fins per inch	10	10
†No. & size of air filters		(1) 16-1/2 x 31-1/2 x 1 (1) 16-1/2 x 27-7/8 x 1	(1) 16-1/2 x 31-1/2 x 1 (1) 16-1/2 x 27-7/8 x 1
Refrigerant 22 charge furnished		9 lbs. 12 oz.	12 lbs.
Condensate drain size MPT (in.)		3/4	3/4
Net weight of basic unit (lbs.)		720	750
Optional Duct Enclosure (Without Power Saver)		RT8-65 - *229 lbs.	
Optional Duct Enclosure with Power Saver & controls installed		RD8-65 - *350 lbs.	
Optional Roof Mounting Frame		RMF3-65 - *100 lbs.	
Optional Minimum Fresh Air Damper		OAD3-65 - *7 lbs.	
Optional Combination Ceiling Supply And Return Step Down Diffuser		RTD-65 - *52 lbs.	
Optional Combination Ceiling Supply And Return Flush Diffuser		FD-65 - *26 lbs. **FD-65-D - *33 lbs.	
Combination Supply & Return Air Duct	RTD Diffuser	P-8-9592- *36 lbs.	
	FD Diffuser		

††ARI ratings are in accordance with ARI Standard 240;

Cooling Rating—450 cfm indoor coil air volume per ton of cooling capacity, 95F outdoor air temperature and 80db/67wb entering indoor coil air.

Heating Rating—450 cfm indoor coil air volume, 45F outdoor air temperature and 70db entering indoor coil air.

Heating Application Rating—450 cfm indoor coil air volume, 20F outdoor air temperature and 70db entering indoor coil air.

† Cleanable polyurethane filter media.

* Net weight. ** Flush diffuser with adjustable baffle blades.

ELECTRICAL DATA

Model No.		CHP8-511	CHP8-513		CHP8-651	CHP8-653	
Line voltage data		208/230v 60cy, 1ph	208/240v 60cy, 3ph	440/480v 60cy, 3ph	230v 60cy, 1ph	208/240v 60cy, 3ph	440/480v 60cy, 3ph
Compressor	Full load amps	28.0	19.3	9.6	33.8	23.3	11.7
	Power factor	.92	.85	.85	.92	.85	.85
	Locked rotor amps	125.0	100.0	45.0	135.0	110.0	56.0
Outdoor Coil Fan	Full load amps	3.4	3.4	*1.7	3.4	3.4	*1.7
	Locked rotor amps	7.1	7.1	7.1	7.1	7.1	7.1
Indoor Coil Blower	Full load amps	4.0	4.0	*2.0	4.0	4.0	*2.0
	Locked rotor amps	9.6	9.6	9.6	9.6	9.6	9.6
Maximum unit amps		35.4	26.7	13.3	41.2	30.7	15.4
AWG Wire Size	1' to 100' run	6	8	12	6	8	12
	101' to 200' run	4	6	10	4	6	10
Time delay fuse, fusetron (amps)		45	35	20	60	40	20
Maximum allowable fuse (amps)		70	50	25	80	50	30
Disconnect rating (hp)		7-1/2	15	15	10	15	15

* Motors are rated at 230v, FLA shown is for step down transformer.

NOTE—If other than time delay fuses are used the next larger amp rating may be required.

NOTE—All fuses, disconnect and wiring must conform to NEC and local codes. Wire sizes are according to NEC for copper conductors.

NOTE—Extremes of operating range are plus and minus 10% of line voltage.

FIELD WIRING

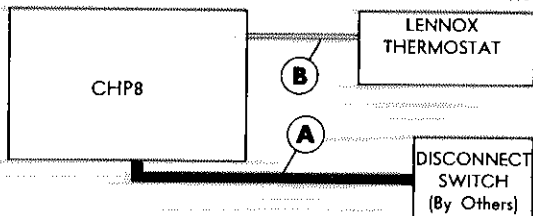

Additional field wiring is not required when POWER SAVER is used. All wiring is provided in CHP8 and in POWER SAVER, simply make plug-in connections to complete the job.

All wiring must conform to NEC and local electrical codes.

If local electrical code permits may be class 2 wiring.

A—Two or three wire power—see electrical data table

B—Five wire low voltage-18 ga. minimum

CHP8-511-513 OPTIONAL ELECTRIC HEAT

CHP8-511-513 OPTIONAL ELECTRIC HEAT

CHP8 Model No.	*Optional Electric Unit Model No.	No. of Steps	Volts Input	Electric Heat Kw Input	Electric Heat Btuh Output	Electric Heat Amps	Maximum Unit Amps	AWG Wire Size	Time Delay Fuse Fusetron (Amps)	Disconnect Rating Hp
CHP8-511	ECH8-65-321 (55 lbs.)	2	208	7.1	24,000	34.0	69.4	3	80	20
			220	7.9	27,000	35.9	71.3	2	90	20
			230	8.6	29,500	37.6	73.0	2	90	20
			240	9.4	32,000	39.2	74.6	2	90	20
	ECH8-65-641 (59 lbs.)	4	208	14.1	48,000	68.0	103.4	0	125	30
			220	15.8	54,000	71.8	107.2	00	150	30
			230	17.3	59,000	75.2	110.6	00	150	30
			240	18.8	64,000	78.4	113.8	00	150	30
	ECH8-65-961 (63 lbs.)	6	208	21.2	72,000	102.0	137.4	000	175	40
			220	23.8	81,000	107.8	143.2	0000	200	40
			230	26.0	88,500	112.8	148.2	0000	200	40
			240	28.2	96,000	117.6	153.0	0000	200	40
CHP8-513	ECH8-65-293 (65 lbs.)	1	208	6.2	21,000	17.2	43.9	6	60	20
			220	6.9	23,600	18.2	44.9	6	60	20
			230	7.6	25,900	19.1	45.8	6	60	20
			240	8.3	28,200	19.9	46.4	6	60	20
	ECH8-65-593 (69 lbs.)	2	208	12.4	42,200	34.5	61.2	4	70	30
			220	13.9	47,200	36.6	63.3	3	80	30
			230	15.2	51,800	38.3	65.0	3	80	30
			240	16.6	56,400	39.9	66.6	3	80	30
	ECH8-65-883 (73 lbs.)	3	208	18.6	63,300	51.6	78.3	2	100	40
			220	20.8	70,800	54.7	81.4	1	110	40
			230	22.7	77,700	57.1	83.8	1	110	40
			240	24.8	84,800	59.7	86.4	1	110	40
	ECH8-65-373-480 (63 lbs.)	1	440	9.2	31,500	12.1	25.3	10	30	20
			480	11.0	37,500	13.2	26.5	10	30	20
	ECH8-65-753-480 (65 lbs.)	2	440	18.5	63,000	24.3	37.6	6	50	30
			480	22.0	75,000	26.5	39.8	6	50	30
	ECH8-65-1123-480 (67 lbs.)	3	440	27.7	94,500	36.4	49.7	4	70	40
			480	33.0	112,500	39.7	53.0	4	70	50

*Includes net weight of electric unit.

CHP8-651-653 OPTIONAL ELECTRIC HEAT

CHP8 Model No.	*Optional Electric Unit Model No.	No. of Steps	Volts Input	Electric Heat Kw Input	Electric Heat Btuh Output	Electric Heat Amps	Maximum Unit Amps	AWG Wire Size	Time Delay Fuse Fusetron (Amps)	Disconnect Rating Hp
CHP8-651	ECH8-65-321 (55 lbs.)	2	208	7.1	24,000	34.0	75.2	2	90	20
			220	7.9	27,000	35.9	77.1	2	90	20
			230	8.6	29,500	37.6	78.8	2	90	20
			240	9.4	32,000	39.2	80.4	2	90	20
	ECH8-65-641 (59 lbs.)	4	208	14.1	48,000	68.0	109.2	00	150	30
			220	15.8	54,000	71.8	113.0	00	150	30
			230	17.3	59,000	75.2	116.4	00	150	30
			240	18.8	64,000	78.4	119.6	00	150	30
	ECH8-65-961 (63 lbs.)	6	208	21.2	72,000	102.0	143.2	000	175	40
			220	23.8	81,000	107.8	149.0	0000	200	40
			230	26.0	88,500	112.8	154.0	0000	200	40
			240	28.2	96,000	117.6	158.8	0000	200	40
ECH8-65-1121 (65 lbs.)	7	208	24.7	84,000	119.0	160.2	0000	200	40	
		220	27.7	94,500	125.7	166.9	250M	225	40	
		230	30.3	103,250	131.6	172.8	250M	225	40	
		240	32.9	112,000	137.2	178.4	250M	225	50	
CHP8-653	ECH8-65-293 (65 lbs.)	1	208	6.2	21,100	17.2	47.9	4	60	20
			220	6.9	23,600	18.2	48.9	4	60	20
			230	7.6	25,900	19.1	49.8	4	60	20
			240	8.3	28,200	19.9	50.6	4	60	20
	ECH8-65-593 (69 lbs.)	2	208	12.4	42,200	34.5	65.2	3	80	30
			220	13.9	47,200	36.6	67.3	3	80	30
			230	15.2	51,800	38.3	69.0	3	80	30
			240	16.6	56,400	39.9	70.6	3	80	30
	ECH8-65-883 (73 lbs.)	3	208	18.6	63,300	51.6	82.3	1	100	40
			220	20.8	70,800	54.7	85.4	1	110	40
			230	22.7	77,700	57.1	87.8	1	110	40
			240	24.8	84,800	59.7	90.4	1	110	40
ECH8-65-373-480 (63 lbs.)	1	440	9.2	31,500	12.1	27.5	8	40	25	
		480	11.0	37,500	13.2	28.6	8	40	25	
ECH8-65-753-480 (65 lbs.)	2	440	18.5	63,000	24.3	39.7	6	50	40	
		480	22.0	75,000	26.5	41.9	6	50	40	
ECH8-65-1123-480 (67 lbs.)	3	440	27.7	94,500	36.4	51.8	4	70	50	
		480	33.0	112,500	39.7	55.1	4	70	50	

*Includes net weight of electric unit.

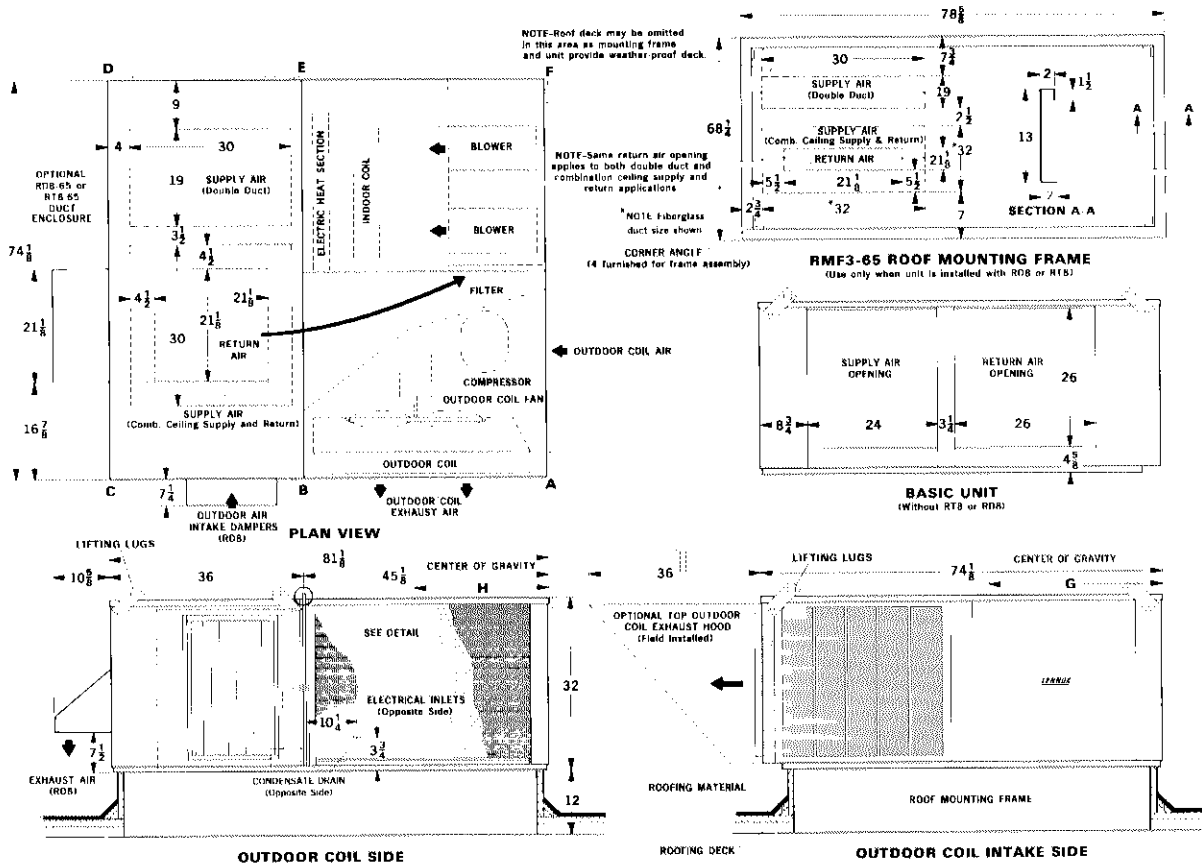

CORNER WEIGHTS (lbs.)

Unit	A	B	C	D	E	F
Basic unit	217	159	---	---	158	216
With RT8	314	---	152	145	---	299
With RD8	343	---	194	167	---	296

CENTER OF GRAVITY

Unit	G	H
Basic unit	37 1/4	19
With RT8	38	26 3/8
With RD8	39 7/8	29-1/2

COMBINATION CEILING SUPPLY & RETURN AIR DISTRIBUTION SYSTEM
Rooftop Unit With Optional Fiberglass Duct

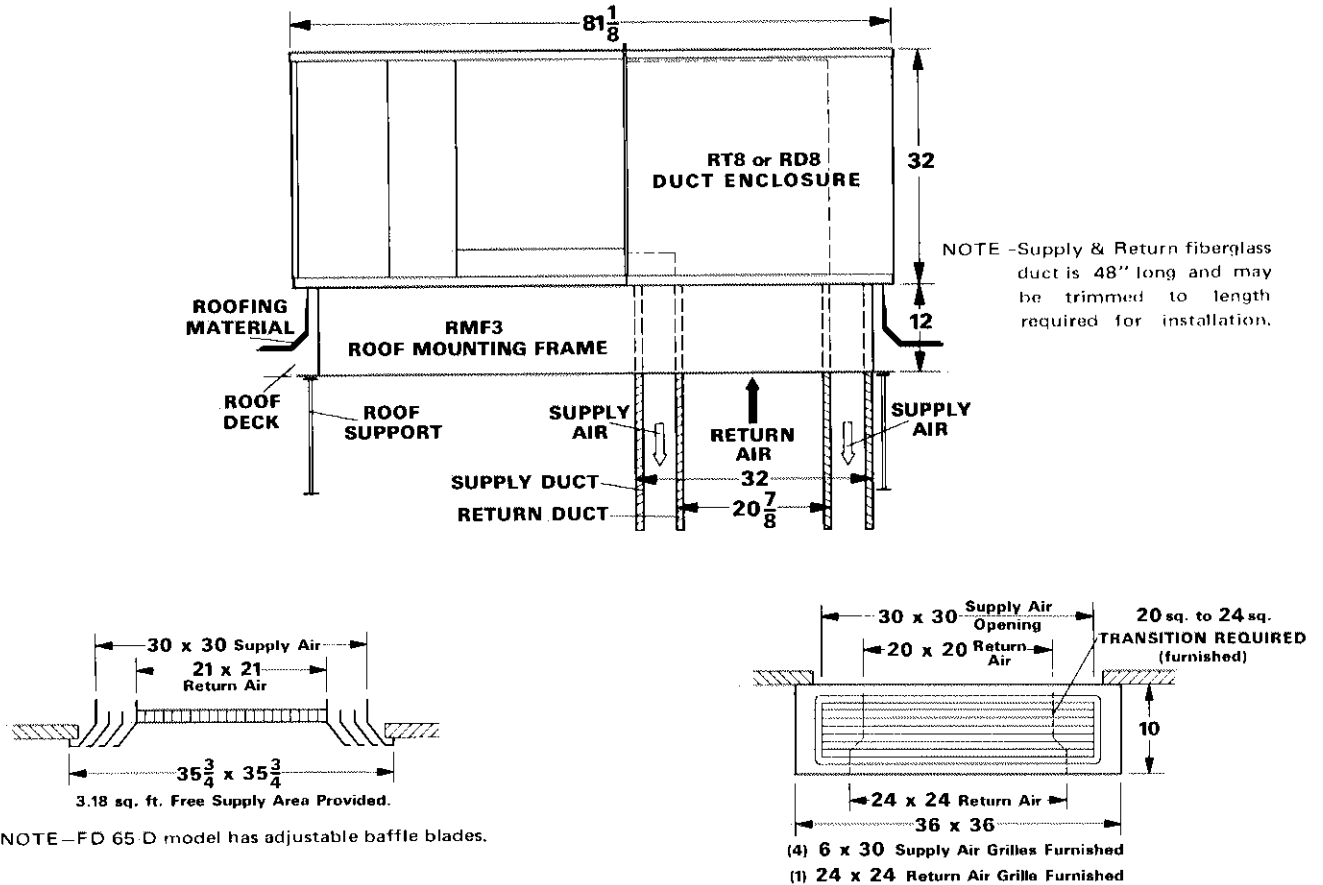

OPTIONAL OAD3-65

MINIMUM FRESH AIR DAMPER

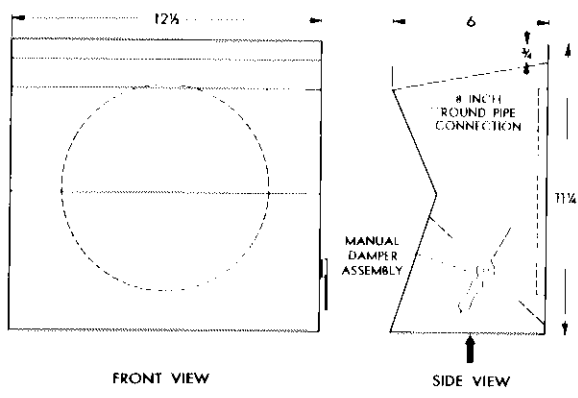

RECOMMENDED FLASHING FOR RMF3 ROOF MOUNTING FRAME

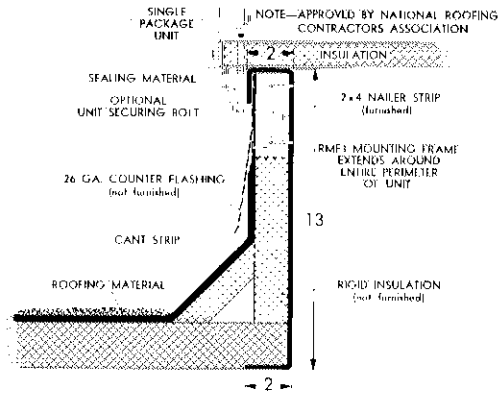

RD8 or RT8 MOUNTING DETAIL

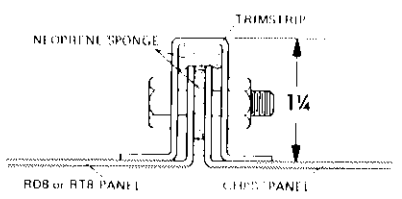

RD8 or RT8 is attached to the CHP8 unit with a minimum amount of time and labor. Trim strips and five bolts, in pre-punched holes, provide a weatherproof seal between the cabinets.

RATINGS

CHP8-511-513 HEAT PUMP COOLING CAPACITY

Indoor Coil 80F Dry Bulb		Air Temperature Entering Outdoor Coil (F)											
Entering Wet Bulb (F)	Total Air Volume (Cfm)	85			95			105			115		
		Total Cooling Capacity (Btuh)	Sensible To Total Ratio (S/T)	Comp. Motor Watts Input	Total Cooling Capacity (Btuh)	Sensible To Total Ratio (S/T)	Comp. Motor Watts Input	Total Cooling Capacity (Btuh)	Sensible To Total Ratio (S/T)	Comp. Motor Watts Input	Total Cooling Capacity (Btuh)	Sensible To Total Ratio (S/T)	Comp. Motor Watts Input
63	1600	49,200	.89	5310	45,700	.92	5620	41,300	.96	5980	35,500	1.00	6140
	1800	50,300	.90	5380	47,200	.93	5720	42,700	.98	6080	37,000	1.00	6260
	2000	51,400	.92	5440	48,400	.95	5800	44,000	.99	6170	38,200	1.00	6370
67	1600	52,200	.71	5480	49,000	.74	5840	44,200	.78	6190	38,500	.81	6400
	1800	53,100	.75	5530	50,000	.78	5900	45,200	.81	6270	39,400	.86	6480
	2000	54,000	.77	5580	51,200	.80	5980	46,300	.84	6350	40,400	.89	6560
71	1600	54,100	.56	5590	51,500	.57	6000	47,400	.61	6430	41,700	.62	6670
	1800	55,100	.59	5650	52,500	.61	6070	48,500	.63	6510	43,300	.64	6810
	2000	56,100	.61	5700	53,700	.63	6150	49,700	.65	6610	44,600	.69	6920

CHP8-511-513 HEAT PUMP HEATING CAPACITY

Indoor Coil Air Volume (Cfm) 70F DB	Air Temperature Entering Outdoor Coil (F)							
	65		45		25		5	
	Total Heating Capacity (Btuh)	Comp. Motor Watts Input	Total Heating Capacity (Btuh)	Comp. Motor Watts Input	Total Heating Capacity (Btuh)	Comp. Motor Watts Input	Total Heating Capacity (Btuh)	Comp. Motor Watts Input
1600	53,000	5450	46,500	4780	29,800	4060	20,000	3320
1800	55,000	5300	48,000	4700	30,800	3970	20,800	3250
2000	57,500	5220	50,200	4610	32,200	3900	21,500	3200

NOTE—Heating capacities include the effect of defrost cycles in the temperature range where they occur.

**CHP8-511-513 HEATING PERFORMANCE
at 1800 Cfm Indoor Coil Air Volume**

*Outdoor Temp. °F	Comp. Motor Watts Input	Total Output (Btuh)
65	5300	55,000
60	5150	53,500
55	5000	51,800
50	4860	50,000
45	4200	48,000
40	4500	40,600
35	4310	35,800
30	4140	33,100
25	3970	30,800
20	3790	28,300
15	3600	26,000
10	3430	23,200
5	3260	20,800
0	3100	18,000

*Outdoor temperature at 85% relative humidity.
Indoor temperature at 70°.

RATINGS

CHP8-651-653 HEAT PUMP COOLING CAPACITY

Indoor Coil 80F Dry Bulb		Air Temperature Entering Outdoor Coil (F)											
		85			95			105			115		
Entering Wet Bulb (F)	Total Air Volume (CFM)	Total Cooling Capacity (Btuh)	Sensible To Total Ratio (S/T)	Comp. Motor Watts Input	Total Cooling Capacity (Btuh)	Sensible To Total Ratio (S/T)	Comp. Motor Watts Input	Total Cooling Capacity (Btuh)	Sensible To Total Ratio (S/T)	Comp. Motor Watts Input	Total Cooling Capacity (Btuh)	Sensible To Total Ratio (S/T)	Comp. Motor Watts Input
63	2000	59,000	.85	6600	54,900	.88	6940	48,700	.92	7160	39,000	.98	7280
	2250	60,500	.87	6670	57,000	.90	7060	51,400	.94	7340	41,500	.99	7460
	2500	61,800	.90	6750	58,600	.92	7160	53,200	.97	7460	44,000	1.00	7650
67	2000	62,000	.71	6750	59,000	.73	7190	53,700	.76	7500	44,500	.81	7690
	2250	63,100	.72	6810	60,300	.74	7260	55,500	.77	7610	46,400	.82	7820
	2500	63,800	.74	6850	61,800	.75	7350	57,000	.78	7710	47,800	.84	7960
71	2000	64,900	.53	6900	62,100	.54	7360	57,300	.56	7740	48,400	.58	7970
	2250	66,000	.55	6970	63,400	.56	7440	58,600	.57	7820	49,800	.60	8070
	2500	66,900	.56	7010	64,800	.57	7530	60,200	.58	7930	51,500	.62	8200

CHP8-651-653 HEAT PUMP HEATING CAPACITY

Indoor Coil Air Volume (Cfm) 70F DB	Air Temperature Entering Outdoor Coil (F)							
	65		45		25		5	
	Total Heating Capacity (Btuh)	Comp. Motor Watts Input	Total Heating Capacity (Btuh)	Comp. Motor Watts Input	Total Heating Capacity (Btuh)	Comp. Motor Watts Input	Total Heating Capacity (Btuh)	Comp. Motor Watts Input
2000	78,500	7250	58,500	6010	40,000	4780	29,500	3800
2250	83,500	7080	61,000	5910	42,000	4680	30,000	3720
2500	88,500	6900	64,000	5780	43,500	4590	31,000	3680

NOTE—Heating capacities include the effect of defrost cycles in the temperature range where they occur.

CHP8-651-653 HEATING PERFORMANCE at 2250 Indoor Coil Air Volume

*Outdoor Temp. °F	Comp. Motor Watts Input	Total Output (Btuh)
65	7080	81,500
60	6800	75,800
55	6500	60,000
50	6200	64,500
45	5910	59,000
40	5600	52,000
35	5300	47,000
30	4970	43,200
25	4680	40,000
20	4400	36,500
15	4160	33,500
10	3950	31,000
5	3720	28,000
0	3500	25,500

*Outdoor temperature at 85% relative humidity.
Indoor temperature at 70°.

BLOWER DATA

CHP8-511-513 BLOWER PERFORMANCE

External Static Pressure (in. wg)	Air Volume (cfm) @ Various Controller Speeds		
	High	Medium	Low
0	2165	1810	1490
.05	2120	1775	1465
.10	2070	1745	1440
.15	2025	1710	1420
.20	1980	1675	1390
.25	1930	1640	1365
.30	1880	1605	1335
.40	1780	1550	1270
.50	1680	1435	1180
.60	1570	1340	1050
.70	1450	1230	---

NOTE—All Cfm data is measured external to the unit using standard return air opening and with the air filter in place.

CHP8-511-513 BLOWER PERFORMANCE WITH RD8-65 AND DUCT DISTRIBUTION

External Static Pressure (in. wg)	Air Volume (cfm) @ Various Controller Speeds		
	High	Medium	Low
0	2065	1755	1470
.05	2025	1720	1440
.10	1980	1685	1415
.15	1930	1655	1390
.20	1890	1620	1355
.25	1840	1585	1325
.30	1795	1545	1290
.40	1695	1470	1215
.50	1595	1380	1110
.60	1485	1285	---
.70	1370	1175	---

NOTE—All Cfm data is measured external to the unit using standard return air opening and with the air filter in place.

CHP8-651-653 BLOWER PERFORMANCE

External Static Pressure (in. wg)	Air Volume (cfm) @ Various Controller Speeds		
	High	Medium	Low
0	2380	1960	1590
.05	2320	1925	1570
.10	2270	1885	1545
.15	2220	1850	1520
.20	2165	1810	1490
.25	1110	1770	1460
.30	2060	1730	1430
.40	1950	1640	1360
.50	1840	1550	1280
.60	1715	1450	---
.70	1585	---	---

NOTE—All Cfm data is measured external to the unit using standard return air opening and with the air filter in place.

CHP8-651-653 BLOWER PERFORMANCE WITH RD8-65 AND DUCT DISTRIBUTION

External Static Pressure (in. wg)	Air Volume (cfm) @ Various Controller Speeds		
	High	Medium	Low
0	2235	1885	1560
.05	2190	1850	1535
.10	2145	1815	1510
.15	2100	1775	1480
.20	2055	1740	1450
.25	2005	1700	1410
.30	1955	1660	1380
.40	1850	1575	1300
.50	1735	1485	1225
.60	1615	1390	---
.70	1490	---	---

NOTE—All Cfm data is measured external to the unit using standard return air opening and with the air filter in place.

RTD-65 CEILING DIFFUSER AIR THROW DATA

RTD-65 Step Down Model	Air Volume (cfm)	*Effective Throw (ft)		
		Horizontal Vanes 180° Straight	Horizontal Vanes 22° Down	Horizontal Vanes 45° Down
Two	2000	51	45	31
Sides	2250	56	50	34
Open	2500	61	54	37
Three	2000	35	31	22
Sides	2250	40	35	25
Open	2500	44	39	28
Four	2000	28	25	17
Sides	2250	30	27	18
Open	2500	33	29	20

*Effective throw is terminated at a point where conditioned air velocity has decreased to 50 fpm.

FD-65 AND FD-65-D CEILING DIFFUSER AIR THROW DATA

Air Volume (cfm)	*Effective Throw (ft)
800	7
900	8
1000	9
1200	11
1350	12
1500	14
2000	18
2250	20
2500	22

*Terminated at the point where conditioned air velocity has decreased to 50 fpm.

CHP8-511-513 WITH RD8-65 AND CEILING SUPPLY & RETURN

Blower Speed Controller Setting	Cfm @ Various Controller Speeds With Various Discharge Grille Arrangements			
	FD-65 or FD-65-D Flush Model	RTD-65 Step-Down Model		
		2 Sides Open	3 Sides Open	4 Sides Open
High	1790	1850	1895	1930
Medium	1590	1640	1650	1670
Low	1395	1395	1420	1435

CHP8-651-653 WITH RD8-65 AND CEILING SUPPLY & RETURN

Blower Speed Controller Setting	Cfm @ Various Controller Speeds With Various Discharge Grille Arrangements			
	FD-65 or FD-65-D Flush Model	RTD-65 Step-Down Model		
		2 Sides Open	3 Sides Open	4 Sides Open
High	1900	1970	2025	2060
Medium	1700	1725	1765	1790
Low	1480	1480	1510	1520