

HPXA19 SERIES UNITS

The HPXA19 is a high efficiency residential split-system heat pump unit, which features a two-step scroll compressor and R410A refrigerant. HPXA19 units are available in 2, 3 (-036 and -038 models), 4 and 5 ton sizes. The series includes the HPXA19-038, a 3 ton unit equipped with a variable speed condenser fan motor. The series is designed for use with an expansion valve only (approved for use with R410A) in the indoor unit. This manual is divided into sections which discuss the major components, refrigerant system, charging procedure, maintenance and operation sequence.

Information contained in this manual is intended for use by qualified service technicians only. All specifications are subject to change.



⚠ IMPORTANT
Operating pressures of this R410A unit are higher than pressures in R22 units. Always use service equipment rated for R410A.

⚠ WARNING
Improper installation, adjustment, alteration, service or maintenance can cause property damage, personal injury or loss of life. Installation and service must be performed by a qualified installer or service agency.

⚠ IMPORTANT
The Clean Air Act of 1990 bans the intentional venting of (CFC's and HFC's) as of July 1, 1992. Approved methods of recovery, recycling or reclaiming must be followed. Fines and/or incarceration may be levied for noncompliance.

⚠ DANGER
Shock Hazard
Remove all power at disconnect before removing access panel. HPXA19 units use single-pole contactors. Potential exists for electrical shock resulting in injury or death. Line voltage exists at all components (even when unit is not in operation).



Table of Contents

General	1	IV Charging	18
Specifications / Electrical Data	2	V Service and Recovery	22
I Application	3	VI Maintenance	22
II Unit Components	3	VII Diagrams and Operating Sequence	23
III Refrigerant System	16		

SPECIFICATIONS

General Data		Model No.	HPXA19-024	HPXA19-036	HPXA19-038	HPXA19-048	HPXA19-060
Nominal Tonnage (kW)			2 (7.0)	3 (10.6)	3 (10.6)	4 (14.1)	5 (17.6)
Connections (sweat)	Liquid line o.d. - in. (mm)		3/8 (9.5)	3/8 (9.5)	3/8 (9.5)	3/8 (9.5)	3/8 (9.5)
	Vapor line o.d. - in. (mm)		7/8 (22.2)	7/8 (22.2)	7/8 (22.2)	7/8 (22.2)	1-1/8 (28.5)
Refrigerant	¹ R-410A furnished		10 lbs. 4 oz. (4.65 kg)	11 lbs. 0 oz. (5.00 kg)	13 lbs. 15 oz. (6.32 kg)	12 lbs. 14 oz. (5.84 kg)	14 lbs. 6 oz. (6.52 kg)
Outdoor Coil	Net face area sq. ft. (m ²) - Outer Coil		16.04 (1.49)	16.04 (1.49)	24.06 (2.24)	24.06 (2.24)	24.06 (2.24)
	Inner Coil		15.56 (1.45)	15.56 (1.45)	23.33 (2.17)	23.33 (2.17)	23.33 (2.17)
	Tube diameter - in. (mm)		5/16 (0.52)	5/16 (0.52)	5/16 (0.52)	5/16 (0.52)	5/16 (0.52)
	Number of rows		2	2	2	2	2
	Fins per inch (m)		22	22	22	22	22
Outdoor Fan	Diameter in. (mm) and no. of blades		24 (610) - 3	24 (610) - 3	24 (610) - 4	24 (610) - 4	24 (610) - 4
	Motor hp (W)		1/10 (74.8)	1/10 (74.8)	1/3 (249)	1/4 (187)	1/4 (187)
	Cfm (L/s)		3159 (1485)	3159 (1485)	3135 (1480) first-stage 3600 (1700) second-stage	3900 (1840)	4200 (1980)
	Rpm		825	825	700 first-stage 820 second-stage	820	820
	Watts		170	170	105 first-stage 150 second-stage	300	350
Shipping Data - lbs. (kg) 1 package			261 (118)	262 (119)	316 (143)	318 (144)	340 (154)

ELECTRICAL DATA

Electrical Data	Line voltage data - 60hz	208/230V-1p h	208/230V-1p h	208/230V-1ph	208/230V-1p h	208/230V-1p h
³ Maximum overcurrent protection (amps)		20	35	40	45	60
² Minimum circuit ampacity		13.7	22.1	23.7	28.2	33.8
Compressor	Rated load amps	10.3	16.7	16.7	21.2	25.7
	Locked rotor amps	52	82	82	96	118
	Power factor	0.99	0.98	0.98	0.99	0.99
Outdoor Coil Fan Motor	Full load amps	0.8	0.8	2.8	1.7	1.7
	Locked rotor amps	2	2	Not Applicable	3.1	3.1

OPTIONAL ACCESSORIES - MUST BE ORDERED EXTRA

Compressor Hard Start Kit	Factory Installed	10J42	10J42	10J42	81J69	81J69
Compressor Low Ambient Cut-off		45F08	45F08	45F08	45F08	45F08
Freezestat	3/8 in. tubing	93G35	93G35	93G35	93G35	93G35
	1/2 in. tubing	39H29	39H29	39H29	39H29	39H29
	5/8 in. tubing	50A93	50A93	50A93	50A93	50A93
³ Indoor Blower Speed Relay Kit		40K58	40K58	40K58	40K58	40K58
Low Ambient Kit		54M89	54M89	68M04	54M89	54M89
Mild Weather Kit		33M07	33M07	33M07	33M07	33M07
Monitor Kit - Service Light		76F53	76F53	76F53	76F53	76F53
Mounting Base	Part No. - Catalog No.	MB2-L (69J07)	MB2-L (69J07)	MB2-L (69J07)	MB2-L (69J07)	MB2-L (69J07)
	Net Weight	15 lbs. (7 kg)	15 lbs. (7 kg)	15 lbs. (7 kg)	15 lbs. (7 kg)	15 lbs. (7 kg)
Outdoor Thermostat Kit	Thermostat	56A87	56A87	56A87	56A87	56A87
	Mounting Box - US	31461	31461	31461	31461	31461
	Canada	33A09	33A09	33A09	33A09	33A09
Refrigerant Line Set	15 ft. (4.6 m) length	L15-65-15	L15-65-15	L15-65-15	L15-65-15	Field Fabricate
	30 ft. (9 m) length	L15-65-30	L15-65-30	L15-65-30	L15-65-30	Field Fabricate
	40 ft. (12 m) length	L15-65-40	L15-65-40	L15-65-40	L15-65-40	Field Fabricate
	50 ft. (15 m) length	L15-65-50	L15-65-50	L15-65-50	L15-65-50	Field Fabricate
SignatureStat™ Programmable Thermostat		51M28	51M28	51M28	51M28	51M28
Time Delay Relay Kit		58M81	58M81	58M81	58M81	58M81

NOTE — Extremes of operating range are plus 10% and minus 5% of line voltage.

¹ Refrigerant charge sufficient for 15 ft. (4.6 m) length of refrigerant lines.

² Refer to National or Canadian Electrical Code manual to determine wire, fuse and disconnect size requirements.

³ HACR type breaker or fuse.

I-APPLICATION

All major components (indoor blower and coil) must be matched according to Lennox recommendations for the compressor to be covered under warranty. Refer to the Engineering Handbook for approved system matchups. A misapplied system will cause erratic operation and can result in early compressor failure.

II-Unit Components

ELECTROSTATIC DISCHARGE (ESD)

Precautions and Procedures

⚠ CAUTION

Electrostatic discharge can affect electronic components. Take precautions during unit installation and service to protect the unit's electronic controls. Precautions will help to avoid control exposure to electrostatic discharge by putting the unit, the control and the technician at the same electrostatic potential. Neutralize electrostatic charge by touching hand and all tools on an unpainted unit surface before performing any service procedure.

A-Two-Stage Scroll Compressor (B1)

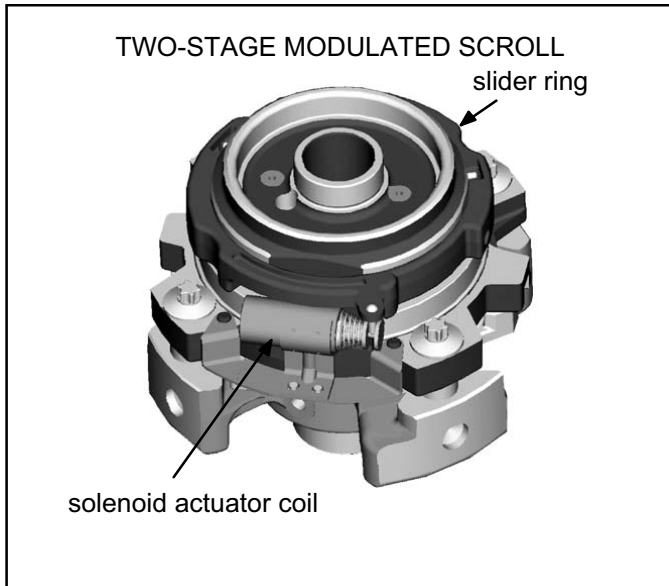

FIGURE 1

The scroll compressor design is simple, efficient and requires few moving parts. A cutaway diagram of the scroll compressor is shown in figure 1. The scrolls are located in the top of the compressor can and the motor is located just below. The oil level is immediately below the motor.

The scroll is a simple compression concept centered around the unique spiral shape of the scroll and its inherent properties. Figure 2 shows the basic scroll form. Two identical scrolls are mated together forming concentric spiral shapes (figure 3). One scroll remains stationary, while the other is allowed to "orbit" (figure 4). Note that the orbiting scroll does not rotate or turn but merely "orbits" the stationary scroll.

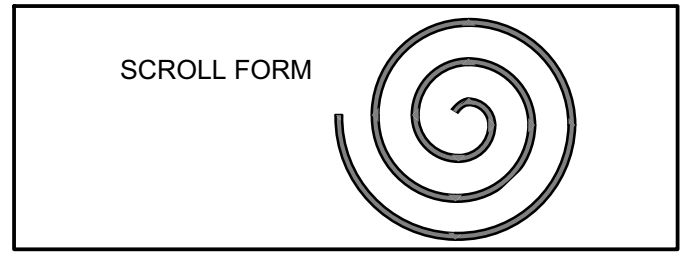

FIGURE 2

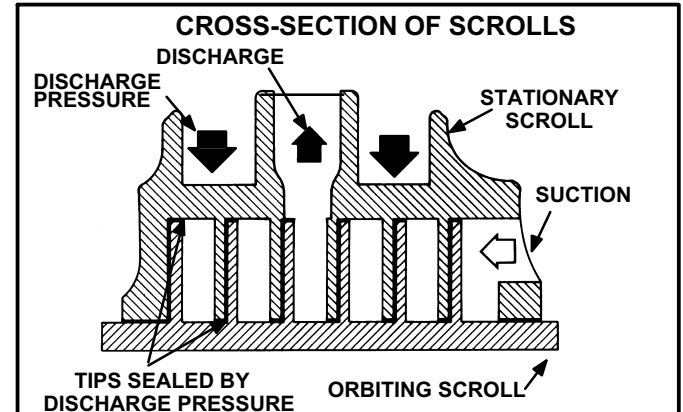

FIGURE 3

The counterclockwise orbiting scroll draws gas into the outer crescent shaped gas pocket created by the two scrolls (figure 4 - 1). The centrifugal action of the orbiting scroll seals off the flanks of the scrolls (figure 4 - 2). As the orbiting motion continues, the gas is forced toward the center of the scroll and the gas pocket becomes compressed (figure 4 - 3). When the compressed gas reaches the center, it is discharged vertically into a chamber and discharge port in the top of the compressor (figure 1). The discharge pressure forcing down on the top scroll helps seal off the upper and lower edges (tips) of the scrolls (figure 3). During a single orbit, several pockets of gas are compressed simultaneously providing smooth continuous compression.

The scroll compressor is tolerant to the effects of liquid return. If liquid enters the scrolls, the orbiting scroll is allowed to separate from the stationary scroll. The liquid is worked toward the center of the scroll and is discharged.

Due to its efficiency, the scroll compressor is capable of drawing a much deeper vacuum than reciprocating compressors. Deep vacuum operation can cause internal fusite arcing resulting in damaged internal parts and will result in compressor failure. This type of damage can be detected and will result in denial of warranty claims. The scroll compressor can be used to pump down refrigerant as long as the pressure is not reduced below 7 psig.

NOTE - During operation, the head of a scroll compressor may be hot since it is in constant contact with discharge gas.

The scroll compressors in all HPXA19 model units are designed for use with R410A refrigerant and operation at high pressures. Compressors are shipped from the factory with 3MA (32MMA) P.O.E. oil. See electrical section in this manual for compressor specifications.

TWO-STAGE OPERATION

The two-stage scroll compressor operates like any standard scroll compressor with the exception the two-stage compressor modulates between first stage (low capacity approximately 67%) and second stage (high capacity). Modulation occurs when gas is bypassed through bypass ports (figure 5 bypass ports open) in the first suction pocket. This bypassing of gas allows the compressor to operate on first stage (low capacity) if thermostat demand allows. Indoor thermostat setting will determine first or second

stage operation. The compressor will operate on first-stage until demand is satisfied or the indoor temperature reaches the thermostat set point calling for second-stage.

Second-stage (high capacity) is achieved by blocking the bypass ports (figure 5 bypass ports closed) with a slider ring. The slider ring begins in the open position and is controlled by a **24VDC** internal solenoid. On a Y2 call the internal solenoid closes the slider ring, blocking the bypass ports and bringing the compressor to high capacity. Two-stage modulation can occur during a single thermostat demand as the motor runs continuously while the compressor modulates from first-stage to second-stage.

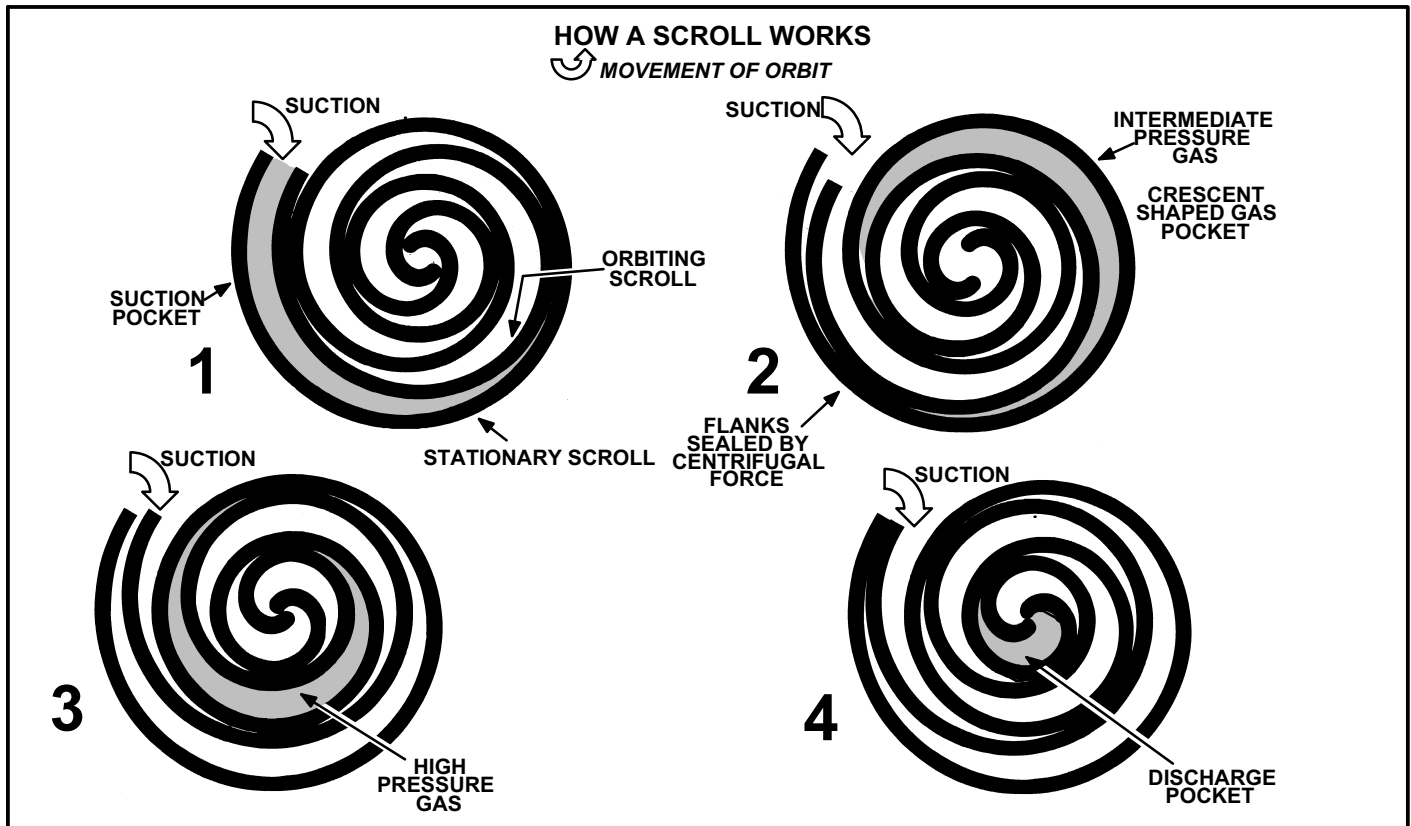

FIGURE 4

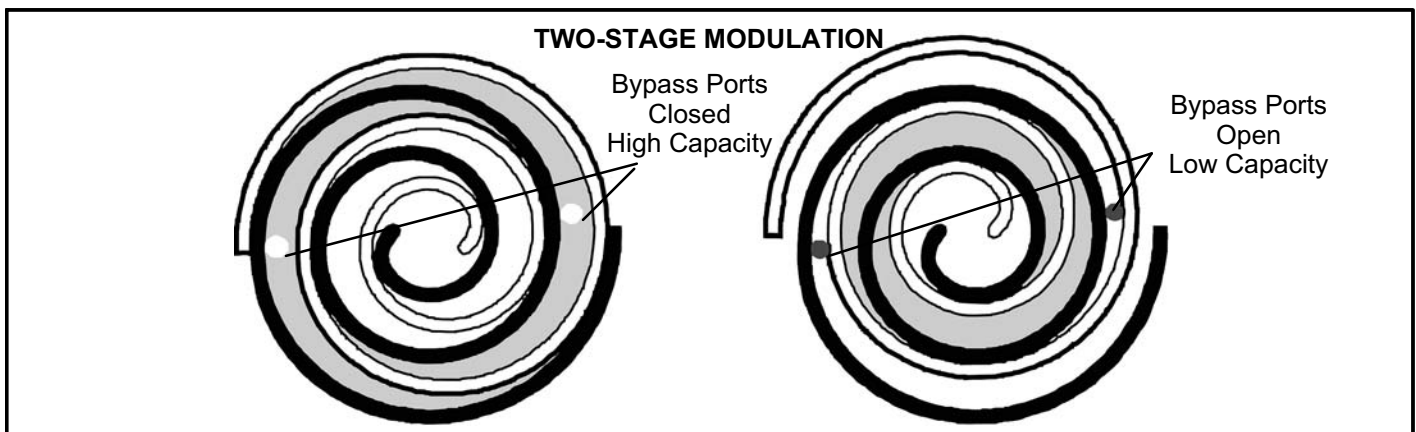

FIGURE 5

INTERNAL SOLENOID (L34)

The internal unloader solenoid controls the two-stage operation of the compressor by shifting a slide ring mechanism to open two by-pass ports in the first compression pocket of the scrolls in the compressor. The internal solenoid is activated by a **24 volt direct current solenoid coil**. The coil power requires 20VAC. The internal wires from the solenoid in the compressor are routed to a 2 pin fusite connection on the side of the compressor shell. The external electrical connection is made to the compressor with a molded plug assembly. This plug contains a full wave rectifier that converts 24 volt AC into 24 volt DC power to power the unloader solenoid. Refer to unit diagram for internal circuitry view of plug.

If it is suspected the unloader is not operating properly, check the following

IMPORTANT

This performance check is ONLY valid on systems that have clean indoor and outdoor coils, proper airflow over coils, and correct system refrigerant charge. All components in the system must be functioning proper to correctly perform compressor modulation operational check. (Accurate measurements are critical to this test as indoor system loading and outdoor ambient can affect variations between low and high capacity readings).

STEP 1 Confirm low to high capacity compressor operation

Tools required

Refrigeration gauge set

Digital volt/amp meter

Electronic temperature thermometer

On-off toggle switch

Procedure

1. Turn main power "OFF" to outdoor unit.
2. Adjust room thermostat set point above (heating operation on heat pump) or below (cooling operation) the room temperature 5°F.
3. Remove control access panel. Install refrigeration gauges on unit. Attach the amp meter to the common (black wire) wire of the compressor harness. Attach thermometer to discharge line as close as possible to the compressor.
4. Turn toggle switch "OFF" and install switch in series with Y2 wire from room thermostat.
5. Cycle main power "ON."
6. Allow pressures and temperatures to stabilize before taking any measured reading (may take up to 10 minutes).

NOTE - Block outdoor coil to maintain a minimum of 375 psig during testing).

7. Record all of the readings for the Y1 demand on table 1.
8. Close switch to energize Y2 demand.
9. Allow pressures and temperatures to stabilize before taking any measured reading (this may take up to 10 minutes).
10. Record all of the readings of Y2 demand on table 1.

NOTE - On new installations or installations that have shut down for an extended period of time, if the compressor does not cycle from low stage to high stage on the first attempt, it may be necessary to recycle the compressor back down to low stage and back up to high stage a few times in order to get the bypass seals to properly seat

Compare Y1 readings with Y2 readings in table 1. Some readings should be higher, lower or the same. If the readings follow what table 1 specifies, the compressor is operating and shifting to high capacity as designed. If the readings do not follow what table 1 specifies, continue to step 2 to determine if problem is with external solenoid plug power.

TABLE 1

Unit Readings	Compressor Operation		
	Y1 - 1st-Stage	Expected Results	Y2 - 2nd-Stage
Compressor			
Voltage		Same	
Amperage		Higher	
Condenser Fan motor			
Amperage		Same or Higher	
Temperature			
Ambient		Same	
Outdoor Coil Discharge Air		Higher in Cooling Lower in Heating	
Compressor Discharge Line		Higher	
Indoor Return Air		Same	
Indoor Coil Discharge Air		Lower in Cooling Higher in Heating	
Pressures			
Suction (Vapor)		Lower	
Liquid		Higher	

STEP 2 Confirm DC voltage output on compressor solenoid plug

A - Compressor solenoid plug **WITH** built in full wave-rectifier (LSOM I) that converts 24 volt AC into 24 volt DC power. See Table 1 for units equipped with the LSOM I.

1. Shut power off to outdoor unit.
2. Supply 24 volts AC control voltage to the wire ends of the full wave rectifier plug. Listen for a “click” as the solenoid is energized. See figure 6.

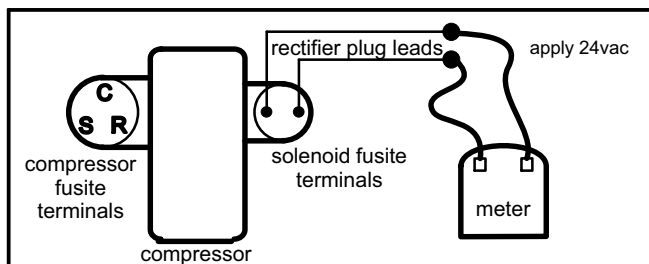

FIGURE 6

3. Unplug the full wave rectifier plug from the fusite connection on the compressor.

4. Turn the low voltage power back onto the unit. Supply 24VAC to the wires of the full wave rectifier plug. Set volt meter to DC volts and measure the DC voltage at the female connector end of the full wave rectifier plug. The DC voltage reading should be 1.5 to 3 volts lower than the input voltage to the plug wire leads. (EX: Input voltage is 24VAC output voltage is 22VDC). See figure 7.

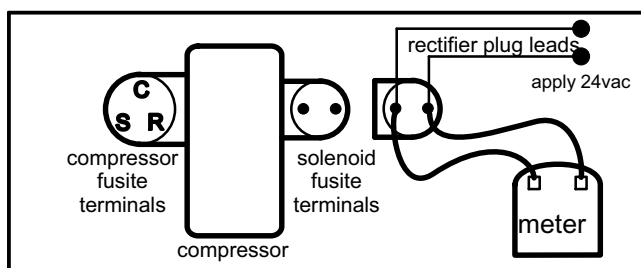

FIGURE 7

If the above checks verify that the solenoid plug is providing power to cycle into high capacity operation, continue to step 3 to determine if problem is with solenoid coil in compressor

STEP 3 Confirm internal unloader solenoid has proper resistance

1. Shut all power off to unit (main and low voltage)
2. Unplug the molded plug from the compressor solenoid 2-pin fusite.
3. Using a volt meter set on the 200 ohm scale

Replace the Compressor under these conditions:

Bad Solenoid

- a. Measure the resistance at the 2-pin fusite. The resistance should be 32 to 60 ohms depending on compressor temperature. If no resist ancereplace compressor.
- b. Measure the resistance from each fusite pin to ground. There should **not be** continuity to ground. If solenoid coil is grounded, replace compressor.

Good Solenoid

- a. Seals not shifting, replace compressor
- b. Slider ring not shifting, replace compressor.

B-Contactor (K1)

The compressor is energized by a contactor located in the control box. All XP19 units are single phase and use single-pole contactors.

C-Low Pressure Switch (S87)

The XP19 is equipped with an auto-reset low pressure switch which is located on the suction line. The switch shuts off the compressor when the suction pressure falls below the factory setting. This switch is ignored during the first 90 seconds of compressor start up, during defrost operation, 90 seconds after defrost operation, during test mode and when the outdoor temperature drops below 15°F.

The switch closes when it is exposed to 55 psig and opens at 25 psig. It is not adjustable.

D-High Pressure Switch (S4)

IMPORTANT

Pressure switch settings for R410A refrigerant will be significantly higher than units with R22.

An auto-reset, single-pole/single-throw high pressure switch is located in the liquid line. This switch shuts off the compressor when liquid line pressure rises above the factory setting. The switch is normally closed and is permanently adjusted to trip (open) at 640 ± 10 psi and close at 448 ± 10 psi. See figure 13 for switch location.

E-Capacitor (C12)

The compressor in XP19-024, -036, -048 and -060 units use a permanent split capacitor (see unit wiring diagram). The capacitor is located inside the unit control box. Ratings are on capacitor side.

F-Condenser Fan with Variable Speed Motor(B4)

The variable speed condenser fan motor (figure 14) used in all units is a three-phase, electronically controlled d.c. brushless motor (controller converts single phase a.c. to three phase d.c.), with a permanent-magnet-type rotor, manufactured by GE. Because this motor has a permanent magnet rotor it does not need brushes like conventional D.C. motors. The motors consist of a control module and motor. Internal components are shown in figure 15. The stator windings are split into three poles which are electrically connected to the controller. This arrangement allows motor windings to be turned on and off in sequence by the controller.

The controller is primarily an a.c. to d.c. converter. Converted d.c. power is used to drive the motor. The controller contains a microprocessor which monitors varying conditions inside the motor (such as motor workload).

G-Contactor (K1)

The compressor is energized by a contactor located in the control box. All HPXA19 units are single phase and use single-pole contactors.

H-Low Pressure Switch (S87)

The HPXA19 is equipped with an auto-reset low pressure switch which is located on the suction line. The switch shuts off the compressor when the suction pressure falls below the factory setting. This switch is ignored during the first 90 seconds of compressor start up, during defrost operation, 90 seconds after defrost operation, during test mode and when the outdoor temperature drops below 15°F.

The switch closes when it is exposed to 55 psig and opens at 25 psig. It is not adjustable.

I-High Pressure Switch (S4)

⚠ IMPORTANT

Pressure switch settings for R410A refrigerant will be significantly higher than units with R22.

An auto-reset, single-pole/single-throw high pressure switch is located in the liquid line. This switch shuts off the compressor when liquid line pressure rises above the factory setting. The switch is normally closed and is permanently adjusted to trip (open) at 640 ± 10 psi and close at 448 ± 10 psi. See figure 13 for switch location.

J-Low Ambient Thermostat (S23) (Second-Stage)

Second-stage low ambient thermostat S23 (figure 8) is a SPST thermostat located in the compressor compartment. The control uses a cap-tube sensor to monitor the temperature inside the compressor compartment. The cap-tube sensor is coiled adjacent to the control.

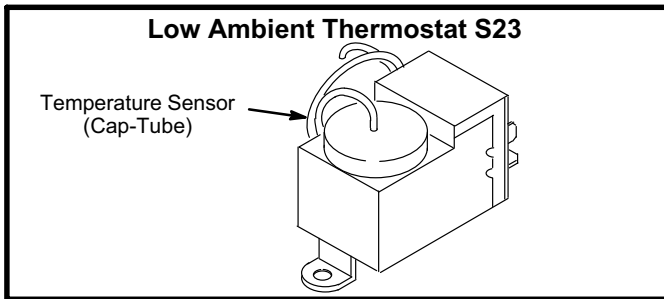

FIGURE 8

S23 continually monitors the temperature inside the compressor compartment. When compressor compartment temperature drops below the control setpoint, the control closes. When the control closes, the contacts shunt across Y1 and Y2 inside the unit. When Y1 heating demand is present and S23 is closed, the compressor will run in high capacity. The compressor will operate in high capacity mode anytime there is a Y1 heating call from indoor thermostat, until the units control box warms and S23 opens.

S23 has field adjustable setpoints. Temperature differential (difference between cut-in and cut-out) is fixed and cannot be adjusted. Table 2 shows S23 control setpoints. The control is factory set to close at $40 \pm 2^\circ\text{F}$ on a temperature drop and reset at $50 \pm 2^\circ\text{F}$ on a temperature rise.

TABLE 2
Control Setpoints

Low Ambient Thermostat Adjustable Range	Factory Setting	Min.	Max.
Cut-In (Close on Temperature Drop)	$40 \pm 2^\circ\text{F}$	$37 \pm 2^\circ\text{F}$	$55 \pm 2^\circ\text{F}$
Cut-Out (Open on Temperature Rise)	$50 \pm 2^\circ\text{F}$	$47 \pm 2^\circ\text{F}$	$65 \pm 2^\circ\text{F}$

Regional climatic conditions may require the control to be adjusted to a different setting. The adjustment screw is located on the control. A hole cut into the bottom shelf of the control box provides access to the control from the compressor compartment. See figure 9.

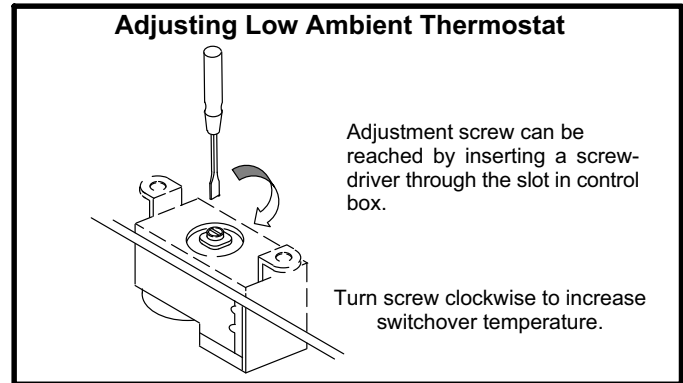

FIGURE 9

Figure 10 shows the adjustment range of the control. Turn adjustment screw clockwise to raise the switchover temperature and counterclockwise to lower the switchover temperature.

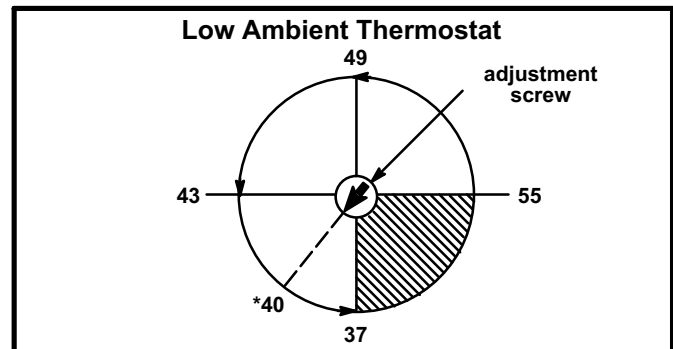

FIGURE 10

K-Reversing Valve (L1)

A refrigerant reversing valve with an electromechanical solenoid is used to reverse refrigerant flow during unit operation. The reversing valve is energized during cooling demand and during defrost.

L-Transformer (T46)

Transformer T46 is located in the control box and is energized any time the compressor is operating.

M-Solenoid Relay (K195)

Relay K195 is N.O. SPDT relay located in the control box. On a Y2 call K195-1 closes allowing AC voltage from (T46) to the two pin full wave rectifier plug (D4).

N-Rectifier Plug (D4)

D4 is a molded assembly that plugs into the compressor. On a Y2 call D4 converts 24 volts AC to 24 volts DC. The DC voltage energizes solenoid L34, allowing the compressor to operate at full capacity.

O-Discharge Line Thermostat (S5)

S5 is an automatic reset SPST N.C. switch which opens on temperature rise. S5 is located on the discharge line and wired in series with S4 high pressure switch on the defrost control board. When discharge line temperature rises to $275^{\circ} \pm 8^{\circ}\text{F}$ the switch opens and shuts down the compressor. The switch resets when discharge line temperature drops to $225^{\circ} \pm 11^{\circ}\text{F}$.

P-Dual Capacitor (C12)

The compressor and fan in HPXA19-024, -036, -048 and -060 units use permanent split capacitor motors. A single "dual" capacitor is used for both the fan motor and the compressor (see unit wiring diagram). The two sides (fan and compressor) of the capacitor have different mfd ratings and may change with each compressor. The capacitor is located inside the unit control box.

Q-Condenser Fan Motor (B4)

HPXA19-024, -036, -048 and -060 units use single-phase PSC fan motors which require a run capacitor. The "FAN" side of the dual capacitor is used for this purpose. In all units, the outdoor fan is controlled by the compressor contactor. See ELECTRICAL DATA and SPECIFICATIONS section for more information. See figure 11 if condenser fan motor replacement is necessary. Rain shield location is critical on the condenser fan assembly. Two shields are used in unison to prevent moisture from entering the motor bearings. Installing the shields to close to the bearing hub will create noise and may affect operation. Installing too far away will allow moisture to enter the bearing, resulting in motor failure. See figure 12.

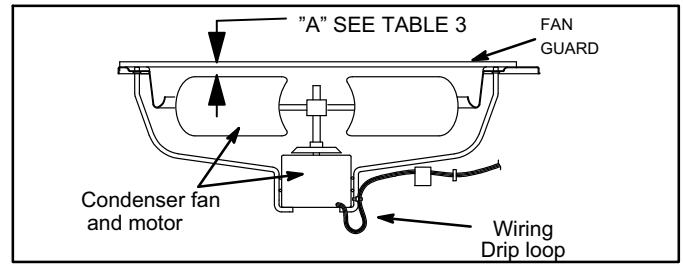

FIGURE 11

TABLE 3

HPXA19 UNIT	"A" DIM. $\pm 1/8$ "
-024, -036	1 1/16"
-038	1 3/16"
-048	
-060	

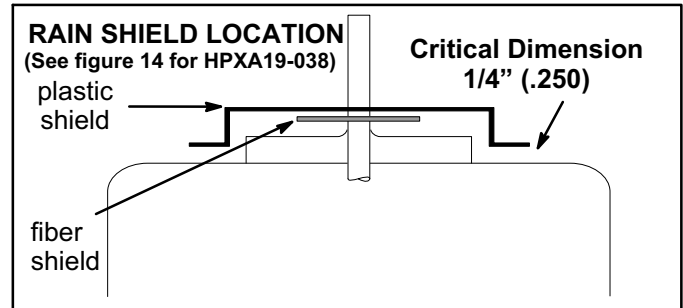

FIGURE 12

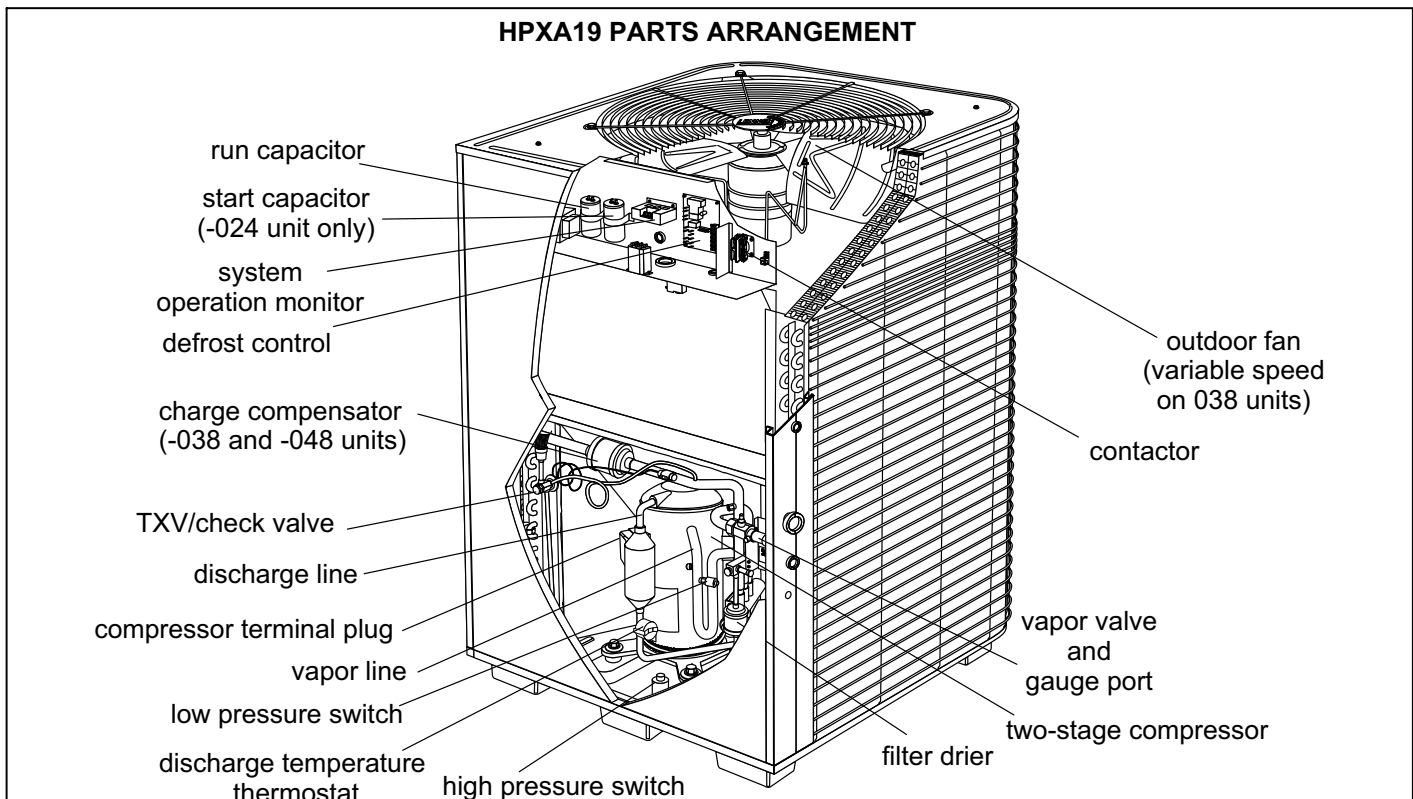

FIGURE 13

R-Condenser Fan with Variable Speed Motor(B4) (-038 only)

The variable speed condenser fan motor (figure 14) used in all HPXA19-038 units is a three-phase, electronically controlled d.c. brushless motor (controller converts single phase a.c. to three phase d.c.), with a permanent-magnet-type rotor, manufactured by GE. Because this motor has a permanent magnet rotor it does not need brushes like conventional D.C. motors. The motors consist of a control module and motor. Internal components are shown in figure 15. The stator windings are split into three poles which are electrically connected to the controller. This arrangement allows motor windings to be turned on and off in sequence by the controller.

The controller is primarily an a.c. to d.c. converter. Converted d.c. power is used to drive the motor. The controller contains a microprocessor which monitors varying conditions inside the motor (such as motor workload).

The controller uses sensing devices to know what position the rotor is in at any given time. By sensing the position of the rotor and then switching the motor windings on and off in sequence, the rotor shaft turns the blower.

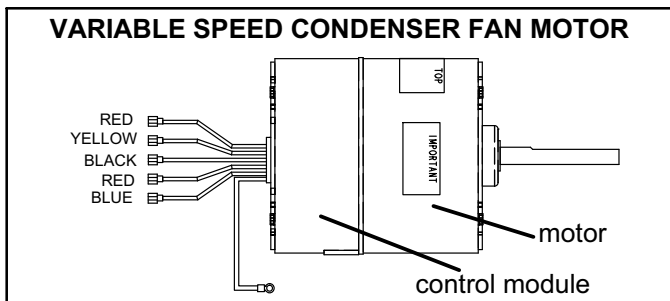

FIGURE 14

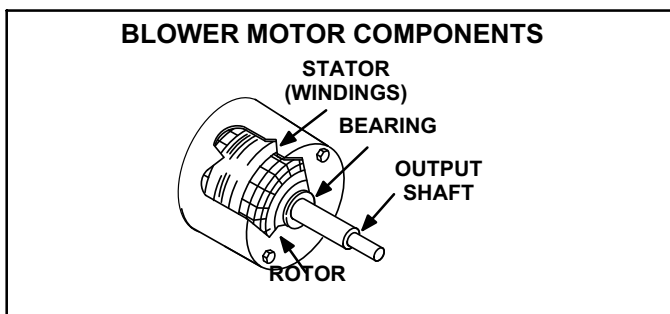

FIGURE 15

Internal Operation

The condenser fan motor is a variable speed motor with RPM settings at 700 (Y1) and 820 (Y2). The variation in speed is accomplished each time the controller switches a stator winding (figure 14) on and off, it is called a "pulse." The length of time each pulse stays on is called the "pulse width." By varying the pulse width the controller varies motor speed (called "pulse-width modulation"). This allows for precise control of motor speed and allows the motor to

compensate for varying load conditions as sensed by the controller. In this case, the controller monitors the static workload on the motor and varies motor rpm in order to maintain constant airflow (cfm).

Motor rpm is continually adjusted internally to maintain constant static pressure against the fan blade. The controller monitors the static work load on the motor and motor amp-draw to determine the amount of rpm adjustment. Blower rpm is adjusted internally to maintain a constant cfm. The amount of adjustment is determined by the incremental taps which are used and the amount of motor loading sensed internally. The motor constantly adjusts rpm to maintain a specified cfm.

Initial Power Up

When line voltage is applied to the motor, there will be a large inrush of power lasting less than 1/4 second. This inrush charges a bank of DC filter capacitors inside the controller. If the disconnect switch is bounced when the disconnect is closed, the disconnect contacts may become welded. Try not to bounce the disconnect switch when applying power to the unit.

The DC filter capacitors inside the controller are connected electrically to the speed tap wires. The capacitors take approximately 5 minutes to discharge when the disconnect is opened. For this reason it is necessary to wait at least 5 minutes after turning off power to the unit before attempting to service motor.

⚠ DANGER

Disconnect power from unit and wait at least five minutes to allow capacitors to discharge before attempting to service motor. Failure to wait may cause personal injury or death.

Motor Start-Up

At start-up, the motor may gently rock back and forth for a moment. This is normal. During this time the electronic controller is determining the exact position of the rotor. Once the motor begins turning, the controller slowly eases the motor up to speed (this is called "soft-start"). The motor may take as long as 10-15 seconds to reach full speed. If the motor does not reach 200rpm within 13 seconds, the motor shuts down. Then the motor will immediately attempt a restart. The shutdown feature provides protection in case of a frozen bearing or blocked fan blade. The motor may attempt to start eight times. If the motor does not start after the eighth try, the controller locks out. Reset controller by momentarily turning off power to unit.

Rain shield location is critical on the condenser fan assembly. Installing the shields too close to the bearing hub will create noise and may affect operation. Installing too far away will allow moisture to enter the bearing resulting in motor failure. See figure 16 .

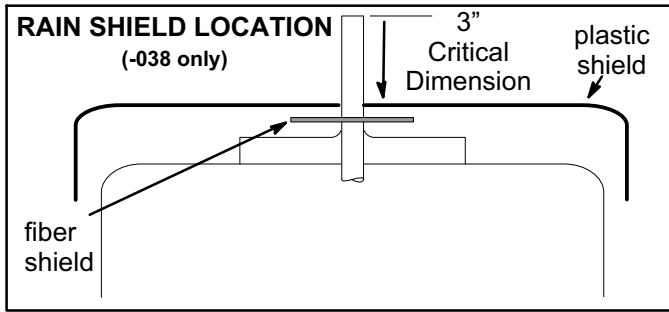

FIGURE 16

Troubleshooting

If first or second stage thermostat call for cool is present and the variable speed condenser fan motor does not energize, check voltage at the breaker box. If voltage is present do the following and reference figure 17.

- 1- Check for 240 volts between the compressor RED wires.
- 2- Initiate a first stage call for cool. Check for 24 volts between the fan motor YELLOW wire and fan motor BLACK wire.
- 3- Initiate a second stage call for cool. Check for 24 volts between the fan motor YELLOW wire and fan motor BLACK wire, then check for 24 volts between the fan motor BLUE wire and fan motor BLACK.
- 4- Repeat steps 1 through 3 with a HEAT call.

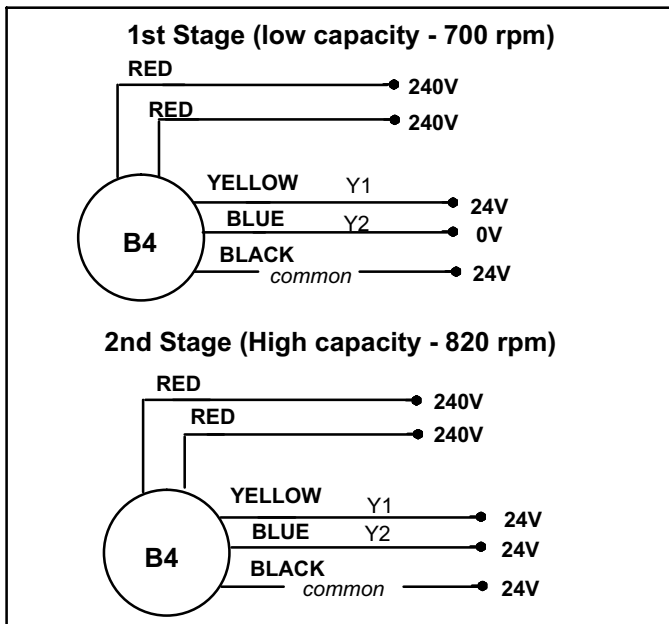

FIGURE 17

S-Filter Drier

A filter drier designed for all HPXA19 model units is factory installed in the liquid line. The filter drier is designed to remove moisture and foreign matter, which can lead to compressor failure.

Moisture and / or Acid Check

Because POE oils absorb moisture, the dryness of the system must be verified any time the refrigerant system is exposed to open air. A compressor oil sample must be taken to determine if excessive moisture has been introduced to the oil. Table 4 lists kits available from Lennox to check POE oils.

If oil sample taken from a system that has been exposed to open air does not test in the dry color range, the filter drier **MUST** be replaced.

⚠ IMPORTANT

Replacement filter drier MUST be approved for R410A refrigerant and POE application.

Foreign Matter Check

It is recommended that a liquid line filter drier be replaced when the pressure drop across the filter drier is greater than 4 psig.

T-Accumulator (HPXA19-060 only)

ALL 5 ton HPXA19 units are equipped with an accumulator. The purpose of the accumulator is to trap and evaporate all liquid refrigerant returning to the compressor.

U-Charge Compensator

HPXA19-038 and -048 series units are equipped with a charge compensator located in the vapor line between the reversing valve and outdoor coil manifold. The compensator is used to collect and store excess refrigerant in the heating mode. Figure 18 shows operation of the charge compensator.

In heating mode, the vapor line passing through the charge compensator tank is cooler than the liquid line. Excess refrigerant (condensed liquid) from the indoor coil is trapped by the compensator. The vapor line is cooler than the liquid line so liquid migrates from the liquid line to the compensator tank where it is stored. In cooling mode, the vapor line passing through the charge compensator tank is hotter than the liquid line. Stored liquid is boiled and forced back into the liquid line for circulation.

TABLE 4

KIT	CONTENTS	TUBE SHELF LIFE
10N46 - Refrigerant Analysis	Checkmate-RT700	
10N45 - Acid Test Tubes	Checkmate-RT750A (three pack)	2 - 3 years @ room temperature. 3+ years refrigerated
10N44 - Moisture Test Tubes	Checkmate - RT751 Tubes (three pack)	6 - 12 months @ room temperature. 2 years refrigerated
74N40 - Easy Oil Test Tubes	Checkmate - RT752C Tubes (three pack)	2 - 3 years @ room temperature. 3+ years refrigerated
74N39 - Acid Test Kit	Sporlan One Shot - TA-1	

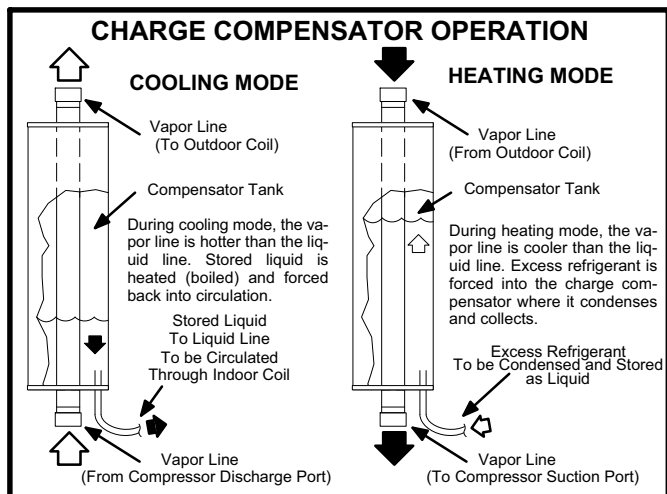

FIGURE 18

V-Lennox System Operation Monitor (A132)

The Lennox system operation monitor (LSOM) is a 24 volt powered module wired directly to the indoor unit. See diagnostic module A132 on wiring diagram and figure 19. The LSOM is located in the control box and is used to troubleshoot problems in the system. The module has three LED's for troubleshooting: GREEN indicates power status, YELLOW indicates an abnormal condition and RED indicates thermostat demand, but compressor not operating. See table 5 for troubleshooting codes.

⚠ IMPORTANT

The LSOM is not a safety component and cannot shut down or control the HPXA19. The LSOM is a monitoring device only.

W-Crankcase Heater (HR1)

Compressors in all units are equipped with a 70 watt belly-band type crankcase heater. HR1 prevents liquid from accumulating in the compressor. HR1 is controlled by the crankcaseheater thermostat.

X- Crankcase heater Thermostat (S40)

Thermostat S40 controls the crankcase heater in all units. S40 is located on the liquid line. When liquid line temperature drops below 50° F the thermostat S40 closes energizing HR1. The thermostat will open, de-energizing HR1 once liquid line temperature reaches 70° F.

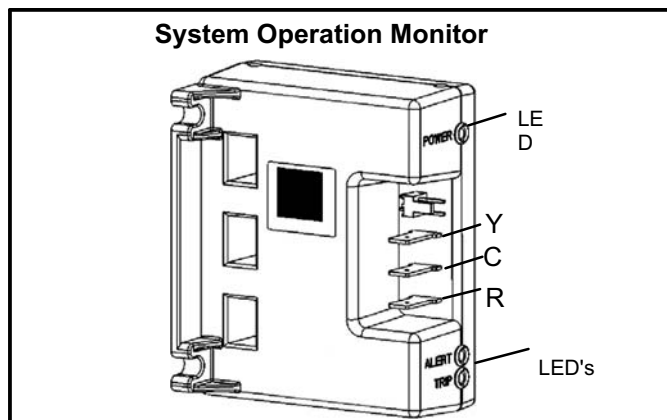

FIGURE 19

Y-Defrost System

The demand defrost controller uses basic differential temperature means to detect when the system performs poorly because of ice build-up on the outdoor coil. The controller also uses "self-calibrating" principles to calibrate itself when the system starts and after every time the system defrosts. The control board has the following components: defrost relays, anti-short cycle timed-off control, pressure switch/safety control, 5-trip lockout circuit, test mode pins, ambient and coil temperature sensors, field selectable termination temperature pins, and a field low voltage connection terminal strip. See figure 20.

The control monitors ambient temperature, outdoor coil temperature and total run time to determine when a defrost cycle is required. Two temperature probes are permanently attached to the control. The coil temperature probe is designed with a spring clip to allow mounting to the outside coil tubing. The location of the coil sensor is important for proper defrost operation. See figure 21 for coil sensor location. The ambient temperature sensor is located in the PVC tube next to the filter drier.

NOTE - The logic of the demand defrost board accurately measures the performance of the system as frost accumulates on the outdoor coil. This typically will translate into longer running time between defrost cycles as more frost accumulates on the outdoor coil before the board initiates defrost cycles.

TABLE 5
System Operation Monitor LED Troubleshooting Codes

Status LED	Status LED Description	Status LED Troubleshooting Information
Green "Power"	Module has power.	24VAC control power is present at the module terminal.
Red "Trip"	Thermostat demand signal Y1 is present, but the compressor is not running. Heat pump only-Trip light will be on during defrost board 5 minute delay with Y thermostat call.	<ol style="list-style-type: none"> 1 Compressor protector is open. 2 Outdoor unit power disconnect is open. 3 Compressor circuit breaker or fuse(s) is open. 4 Broken wire or connector is not making contact. 5 Low pressure switch open if present in the system. 6 Compressor contactor has failed to close.
Yellow "Alert" Flash Code 1 (Does not apply to heat pump or to two-stage split systems)	Long Run Time Compressor is running extremely long run cycles	<ol style="list-style-type: none"> 1 Low refrigerant charge. 2 Evaporator blower is not running. 3 Evaporator coil is frozen. 4 Faulty metering device. 5 Condenser coil is dirty 6 Liquid line restriction (filter drier blocked if present) 7 Thermostat is malfunctioning.
Yellow "Alert" Flash Code 2	System Pressure Trip Discharge or suction pressure out of limits or compressor overloaded	<ol style="list-style-type: none"> 1 High head pressure. 2 Condenser coil poor air circulation (dirty, blocked, damaged). 3 Condenser fan is not running. 4 Return air duct has substantial leakage. 5 If low pressure switch is present, check Flash Code 1 information.
Yellow "Alert" Flash Code 3	Short Cycling Compressor is running only briefly	<ol style="list-style-type: none"> 1 Thermostat demand signal is intermittent. 2 Time delay relay or control board is defective. 3 If high pressure switch is present, check Flash Code 2 information. 4 If low pressure switch is present, check Flash Code 1 information.
Yellow "Alert" Flash Code 4	Locked Rotor	<ol style="list-style-type: none"> 1 Run capacitor has failed. 2 Low line voltage (contact utility if voltage at disconnect is low). 3 Excessive liquid refrigerant in the compressor. 4 Compressor bearings are seized.
Yellow "Alert" Flash Code 5	Open Circuit	<ol style="list-style-type: none"> 1 Outdoor unit power disconnect is open. 2 Unit circuit breaker or fuse(s) is open. 3 Unit contactor has failed to close. 4 High pressure switch is open and requires manual reset. 5 Open circuit in compressor supply wiring or connections. 6 Unusually long compressor protector reset time due to extreme ambient temperature. 7 Compressor windings are damaged.
Yellow "Alert" Flash Code 6	Open Start Circuit Current only in run circuit	<ol style="list-style-type: none"> 1 Run capacitor has failed. 2 Open circuit in compressor start wiring or connections. 3 Compressor start winding is damaged.
Yellow "Alert" Flash Code 7	Open Run Circuit Current only in start circuit	<ol style="list-style-type: none"> 1 Open circuit in compressor start wiring or connections. 2 Compressor start winding is damaged.
Yellow "Alert" Flash Code 8	Welded Contactor Compressor always runs	<ol style="list-style-type: none"> 1 Compressor contactor failed to open. 2 Thermostat demand signal not connected to module.
Yellow "Alert" Flash Code 9	Low Voltage Control circuit < 17VAC	<ol style="list-style-type: none"> 1 Control circuit transformer is overloaded 2 Low line voltage (contact utility if voltage at disconnect is low.)

- Flash code number corresponds to a number of LED flashes, followed by a pause, and then repeated.
- TRIP and ALERT LEDs flashing at the same time indicates that the control circuit voltage is too low for operation.
- Reset ALERT flash code by removing 24VAC power from monitor. Last ALERT flash code will display for 1 minute after monitor is powered on.

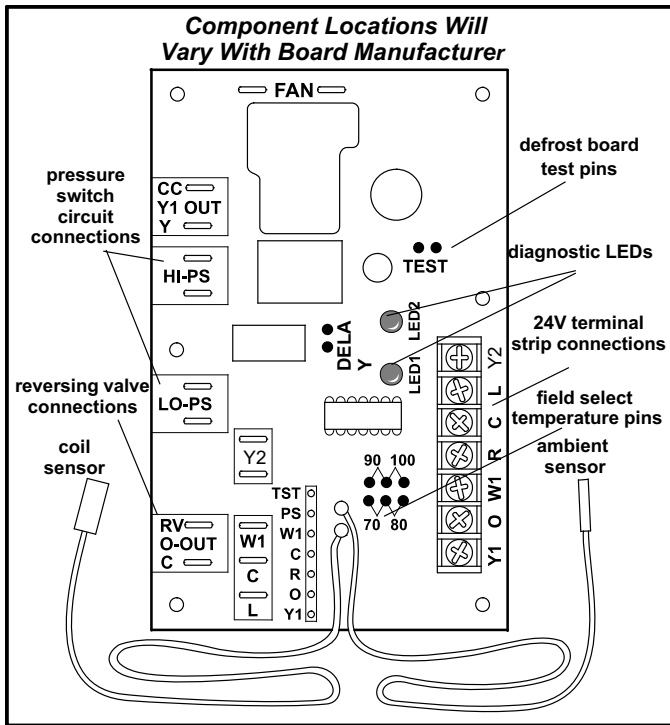

FIGURE 20

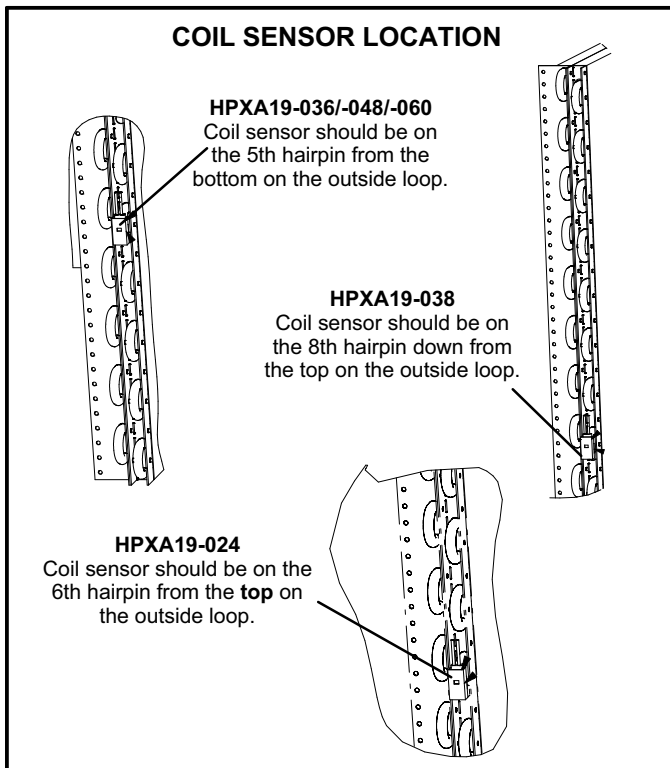

FIGURE 21

The temperature probes cannot be removed from the control. The control and the attached probes **MUST** be replaced as a unit. Do not attempt to cut or splice probe wires.

Diagnostic LEDs

The defrost board uses two LEDs for diagnostics. The LEDs flash a specific sequence according to the diagnostic condition. See table 6.

HI-PS/LO-PS Terminals

High pressure switch (S4) is factory wired into the defrost board HI-PS terminals. When (S4) trips, the defrost board will cycle off the compressor and the strike counter in the board will count one strike.

Low pressure switch (S87) is factory wired into the defrost board LO-PS terminals. When (S87) trips, the defrost board will cycle off the compressor and the strike counter in the board will count one strike.

(S87) is ignored during certain conditions:

- During the defrost cycle and 90 seconds after the termination of defrost
- When the average ambient sensor temperature is below 15 F (-9)
- For 90 seconds following the start up of the compressor
- During "Test" mode

5-Strike Lockout Feature

- The internal control logic of the board counts the pressure switch trips only while the Y1 (Input) line is active. If a pressure switch opens and closes four times during a Y1 (Input), the control logic will reset the pressure switch trip counter to zero at the end of the Y1 (Input). If the pressure switch opens for a fifth time during the current Y1 (Input), the control will enter a lockout condition.
- The 5-strike pressure switch lockout condition can be reset by cycling OFF the 24-volt power to the control board or by shorting the TEST pins. All timer functions (run times) will also be reset.
- If a pressure switch or discharge line thermostat switch opens while the Y1 Out line is engaged, a 5-minute short cycle will occur after the switch closes.

"DELAY" Option

The defrost board has a field selectable function to reduce occasional noise that may occur while the unit is cycling in and out of defrost mode. When a jumper is installed on the "DELAY" pins, the compressor will cycle off for 30 seconds going in and out of defrost mode.

NOTE - 30 second off cycle is not functional when jumpering "TEST" pins.

TABLE 6
Defrost Control Board Diagnostic (5 strike)

LED 1	LED 2	Condition	Possible Cause(s)	Solution
OFF	OFF	Power problem	1 No power (24V) to board terminals R & C. 2 Board failure.	1 Check control transformer power (24V). 2 If power is available and LED(s) are unlit, replace board and all sensors.
ON	ON	Coil sensor problem	1 Coil temperature outside of sensor range. 2 Faulty sensor wiring connections at board or poor sensor contact on coil. 3 Sensor failure.	1 Sensor function will resume when coil temperature is between -20°F and 110°F. 2 Check sensor wiring connections at board and sensor contact on coil. 3 Replace board and all sensors.
OFF	ON	Ambient sensor problem	1 Ambient temperature outside of sensor range. 2 Faulty sensor wiring connections at board or sensor. 3 Sensor failure.	1 Sensor function will resume when coil temperature is between -20°F and 110°F. 2 Check sensor wiring connections at board and sensor. 3 Replace board and all sensors.
FLASH	FLASH	Normal operation	Unit operating normally or in standby mode.	None required.
ON	OFF	5-Strike pressure lockout (Short test pins or reset 24V power to board to override lockout)	1 Restricted air flow over indoor or outdoor coil.	1 Remove any blockages or restrictions. Check outdoor fan motor for proper operation.
ON	FLASH	Low pressure switch circuit open during Y1 demand	2 Improper refrigerant charge. 3 Improper metering device operation.	2 Check approach, superheat & sub-cooling temperatures. 3 Check system pressures. Repair leaks. Replace metering device.
FLASH	ON	High pressure switch or discharge thermostat switch circuit open during Y1 demand	4 Poor contact between coil sensor and coil.	4 Make sure that sensor is properly positioned on coil and that firm contact is established. Refer to service manual for proper placement.
ALTERNATING FLASH	ALTERNATING FLASH	5-minute delay (Jumper test pins to override delay)	Thermostat demand for cooling or heat pump operation. Unit operating in 5-minute anti-short-cycle mode.	None required.

Demand Defrost Operation

The demand defrost control board initiates a defrost cycle based on either frost detection or time.

Frost Detection - If the compressor runs longer than 34 minutes and the actual difference between the clear coil and frosted coil temperatures exceeds the maximum difference allowed by the control, a defrost cycle will be initiated.

IMPORTANT - The demand defrost control board will allow a greater accumulation of frost and will initiate fewer defrost cycles than a time/temperature defrost system.

Time - If 6 hours of heating mode compressor run time has elapsed since the last defrost cycle while the coil temperature remains below 35°F (2°C), the demand defrost control will initiate a defrost cycle.

Action - When the reversing valve is de-energized, the Y1 circuit is energized, and the coil temperature is below 35°F (2°C), the board logs the compressor run time. If the board is not calibrated, a defrost cycle will be initiated after 34 minutes of heating mode compressor run time. The control will attempt to self-calibrate after this (and all other) defrost cycle(s). Calibration success depends on stable system temperatures during the 20-minute calibration period. If the board fails to calibrate, another defrost cycle will be initiated after 90 minutes of heating mode compressor run time. Once the defrost board is calibrated, it will use demand defrost logic to initiate a defrost cycle. A demand defrost system initiates defrost when the difference between the clear coil and frosted coil temperatures exceeds the maximum difference allowed by the control OR after 6 hours of heating mode compressor run time has been logged since the last defrost cycle.

Termination - The defrost cycle ends when the coil temperature exceeds the termination temperature or after 14 minutes of defrost operation. If the defrost is terminated by the 14-minute timer, another defrost cycle will be initiated after 34 minutes of run time.

Test Mode - When Y1 is energized and 24V power is being applied to the board, a test cycle can be initiated by placing the termination temperature jumper across the "Test" pins for 2 to 5 seconds. If the jumper remains across the "Test" pins longer than 5 seconds, the control will ignore the test pins and revert to normal operation. The jumper will initiate one cycle per test.

Operational Description

The defrost control board has three basic operational modes: normal, defrost, and calibration.

Normal Mode

The demand defrost board monitors the O line, to determine the system operating mode (heat/cool), outdoor ambient temperature, coil temperature (outdoor coil) and compressor run time to determine when a defrost cycle is required.

Defrost Mode

When a defrost cycle is initiated, the control energizes the reversing valve solenoid and turns off the condenser fan. The control will also put 24VAC on the W1 (auxiliary heat) line. The unit will stay in this mode until either the coil sensor temperature is above the selected termination temperature, the defrost time of 14 minutes has been completed, or the room thermostat demand cycle has been satisfied. (If the temperature select shunt is not installed, the default termination temperature will be 100°F.) If the room

thermostat demand cycle terminates the cycle, the defrost cycle will be held until the next room thermostat demand cycle. If the coil sensor temperature is still below the selected termination temperature, the control will continue the defrost cycle until the cycle is terminated in one of the methods mentioned above. If a defrost is terminated by time and the coil temperature did not remain above 35°F (2°C) for 4 minutes, the control will go into the 34-minute Time/Temperature mode.

Calibration Mode

The board is considered uncalibrated when power is applied to the board, after cool mode operation, or if the coil temperature exceeds the termination temperature when it is in heat mode.

Calibration of the board occurs after a defrost cycle to ensure that there is no ice on the coil. During calibration, the temperature of both the coil and the ambient sensor are measured to establish the temperature differential which is required to allow a defrost cycle.

Z-Start Capacitor (C7) -024 model only

All 2 ton HPXA19 units are equipped with a start capacitor (C7). The capacitor is located in the control box and wired in parallel with the compressor side of the dual capacitor. C7 is de-energized by potential relay K31 when the compressor nears full speed.

AA-Potential Relay (K31) -024 model only

All 2 ton HPXA19 units are equipped with potential relay K31, which controls the operation of the starting circuit. The relay is located inside the control box and is normally closed when contactor K1 is de-energized. When K1 is energized the compressor begins start up. K31 remains closed during start up and capacitor C7 remains in the circuit. When the compressor reaches 75% of its speed, K31 is energized, de-energizing capacitor C7.

III-REFRIGERANT SYSTEM

Field refrigerant piping consists of liquid and vapor lines from the outdoor unit (sweat connections). Use Lennox L15 series line sets as shown in table 7.

Separate liquid and suction service ports are provided at the service valves for connection of gauge manifold during charging procedure. Figure 22 shows HPXA19 refrigerant flow and gauge manifold connections.

TABLE 7

Model	Valve Field Size Connections		Recommended Line Set		
	Liquid Line	Vapor Line	Liquid Line	Vapor Line	L15 Line Sets
-024,-036	3/8 in. 10 mm	7/8 in. 22 mm	3/8 in. 10 mm	7/8 in. 19 mm	L15-65 15 ft. - 50 ft. 4.6 m - 15 m
-038	3/8 in. 10 mm	7/8 in. 22 mm	3/8 in. 10 mm	7/8 in. 22 mm	L15-65 15 ft. - 50 ft. 4.6 m - 15 m
-048	3/8 in. 10 mm	1-1/8 in. 29 mm	3/8 in. 10 mm	7/8 in. 22 mm	L15-65 15 ft. - 50 ft. 4.6 m - 15 m
-060	3/8 in. 10 mm	1-1/8 in. 29 mm	3/8 in. 10 mm	1-1/8 in. 29 mm	Field Fabricated

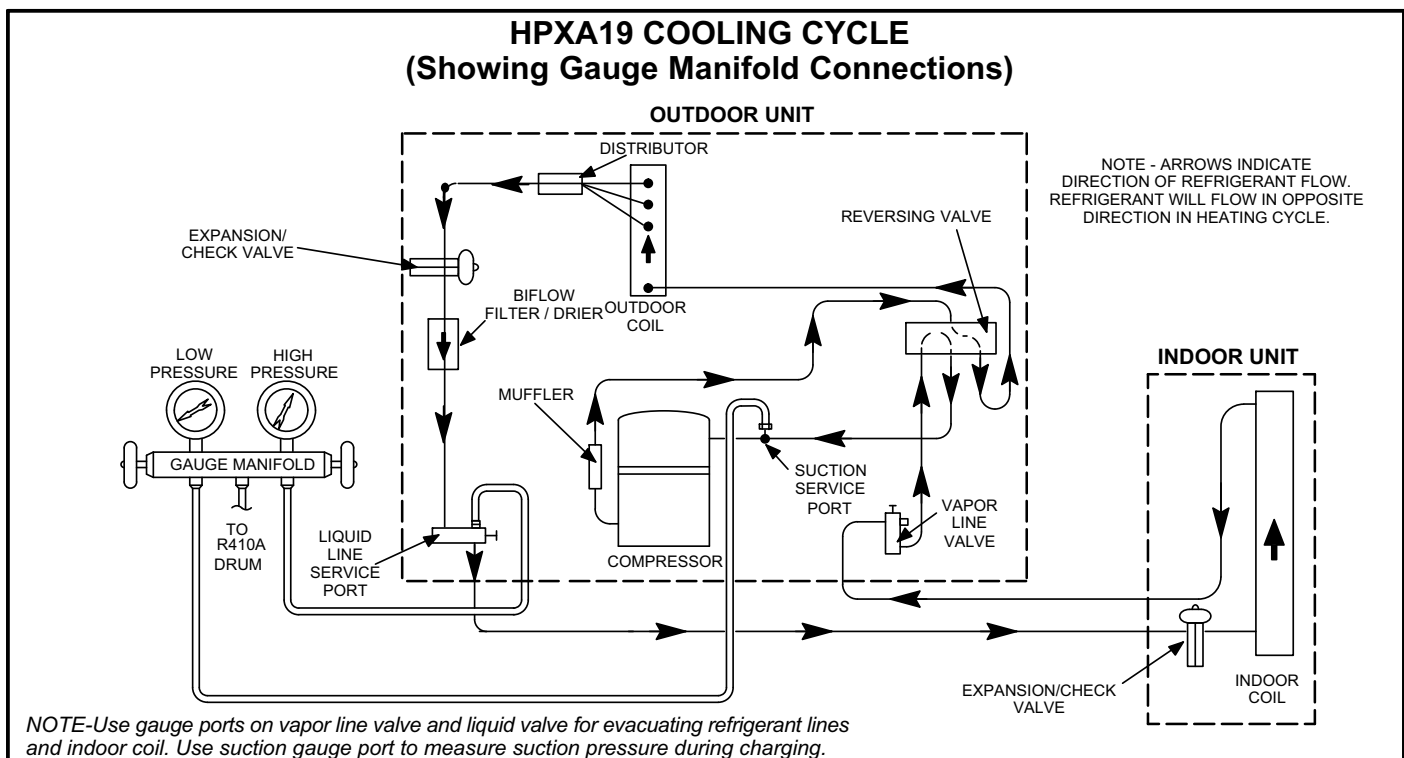

FIGURE 22

A-Service Valves

⚠ IMPORTANT

Only use Allen wrenches of sufficient hardness (50Rc - Rockwell Harness Scale min). Fully insert the wrench into the valve stem recess. Service valve stems are factory torqued (from 9 ft lbs for small valves, to 25 ft lbs for large valves) to prevent refrigerant loss during shipping and handling. Using an Allen wrench rated at less than 50Rc risks rounding or breaking off the wrench, or stripping the valve stem recess.

Access the liquid line and vapor line service valves (figures 23 and 24) and gauge ports are used for leak testing, evacuating, charging and checking charge. See table 8 for torque requirements.

Each valve is equipped with a service port which has a factory-installed Schrader valve. A service port cap protects the Schrader valve from contamination and serves as the primary leak seal.

TABLE 8

Part	Recommended Torque	
Service valve cap	8 ft.- lb.	11 NM
Sheet metal screws	16 in.- lb.	2 NM
Machine screws #10	28 in.- lb.	3 NM
Compressor bolts	90 in.- lb.	10 NM
Gauge port seal cap	8 ft.- lb.	11 NM

⚠ IMPORTANT

Service valves are closed to the outdoor unit and open to line set connections. Do not open the valves until refrigerant lines have been leak tested and evacuated. All precautions should be exercised to keep the system free from dirt, moisture and air.

To Access Schrader Port:

- 1 - Remove service port cap with an adjustable wrench.
- 2 - Connect gauge to the service port.
- 3 - When testing is complete, replace service port cap. Tighten finger tight, then an additional 1/6 turn.

To Open Service Valve:

- 1 - Remove stem cap with an adjustable wrench.
- 2 - Using service wrench and hex head extension, back the stem out counterclockwise as far as it will go.
NOTE - Use a 3/16" hex head extension for liquid line size.
- 3 - Replace stem cap and tighten it firmly. Tighten finger tight, then tighten an additional 1/6 turn.

To Close Service Valve:

- 1 - Remove stem cap with an adjustable wrench.
- 2 - Using service wrench and hex head extension, turn stem clockwise to seat valve. Tighten it firmly.
NOTE - Use a 3/16" hex head extension for liquid line size.
- 3 - Replace stem cap. Tighten finger tight, then tighten an additional 1/6 turn.

Vapor Line (Ball Type) Valve

Vapor line service valves function the same way as the other valves, the difference is in the construction. These valves are not rebuildable. If a valve has failed, you must replace it. A ball valve valve is illustrated in figure 24.

The ball valve is equipped with a service port with a factory-installed Schrader valve. A service port cap protects the Schrader valve from contamination and assures a leak-free seal.

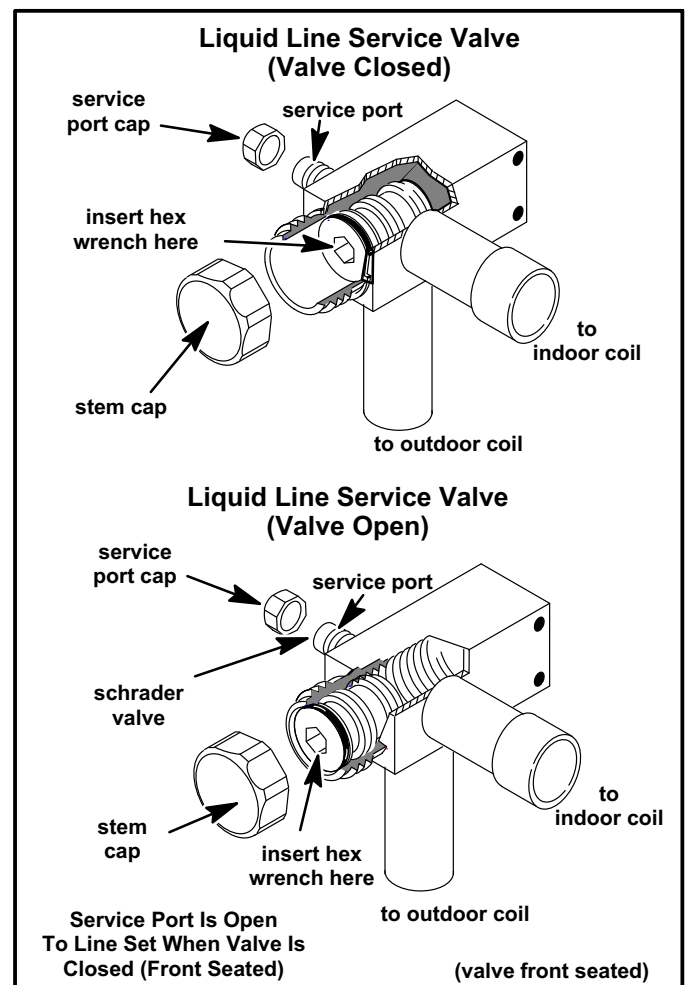

FIGURE 23

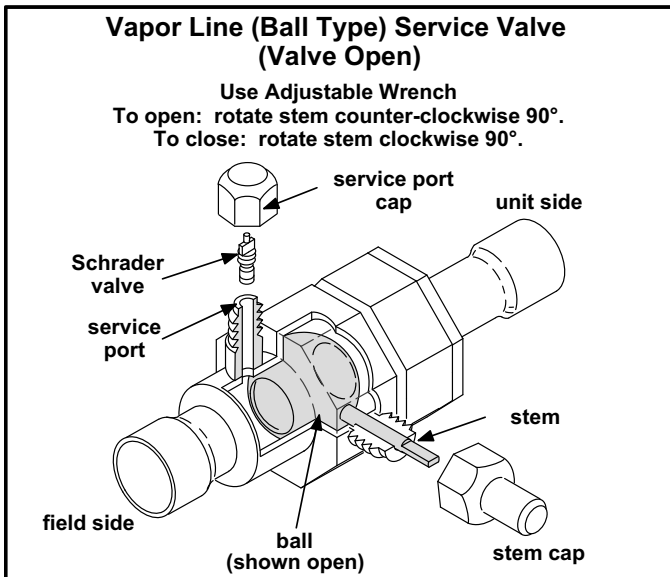

FIGURE 24

IV-CHARGING

Units are factory charged with the amount of R410A refrigerant indicated on the unit rating plate. This charge is based on a matching indoor coil and outdoor coil with 15 ft. (4.6m) line set. For varying lengths of line set, refer to table 9 for refrigerant charge adjustment.

TABLE 9

Liquid Line Set Diameter	Ozs. per 5 ft. (grams per 1.5m) adjust from 15 ft. (4.6m) line set*
3/8 in. (10mm)	3 ounces per 5 feet (85g per 1.5m)

*If line length is greater than 15 ft. (4.6m), add this amount. If line length is less than 15 ft. (4.6), subtract this amount.

A-Leak Testing

After the line set has been connected to the indoor and outdoor units, the line set connections and indoor unit must be checked for leaks.

⚠ WARNING

Refrigerant can be harmful if inhaled. Refrigerant must be used and recovered responsibly. Failure to follow this warning can lead to injury or death.

⚠ WARNING

Danger of explosion!

When using a high pressure gas such as dry nitrogen to pressurize a refrigerant or air conditioning system, use a regulator that can control the pressure down to 1 or 2 psig (6.9 to 13.8 kPa).

⚠ WARNING



Fire, Explosion and Personal Safety Hazard.

Failure to follow this warning could result in damage, personal injury or death.

Never use oxygen to pressurize or purge refrigeration lines. Oxygen, when exposed to a spark or open flame, can cause damage by fire and / or an explosion, that can result in personal injury or death.

Using an Electronic Leak Detector

- 1 - Connect a cylinder of R410A to the center port of the manifold gauge set.
- 2 - With both manifold valves closed, open the valve on the R410A cylinder (vapor only).
- 3 - Open the high pressure side of the manifold to allow the R410A into the line set and indoor unit. Weigh in a trace amount of R410A. [A trace amount is a maximum of 2 ounces (57 g) or 3 pounds (31 kPa) pressure.] Close the valve on the R410A cylinder and the valve on the high pressure side of the manifold gauge set. Disconnect the R410A cylinder.
- 4 - Connect a cylinder of nitrogen with a pressure regulating valve to the center port of the manifold gauge set.
- 5 - Connect the manifold gauge set high pressure hose to the vapor valve service port. (Normally, the high pressure hose is connected to the liquid line port; however, connecting it to the vapor port better protects the manifold gauge set from high pressure damage.)
- 6 - Adjust the nitrogen pressure to 150 psig (1034 kPa). Open the valve on the high side of the manifold gauge set which will pressurize line set and indoor unit.
- 7 - After a few minutes, open a refrigerant port to ensure the refrigerant you added is adequate to be detected. (Amounts of refrigerant will vary with line lengths.) Check all joints for leaks. Purge nitrogen and R410A mixture. Correct any leaks and recheck.

⚠ IMPORTANT

Leak detector must be capable of sensing HFC refrigerant.

B-Evacuating

Evacuating the system of noncondensables is critical for proper operation of the unit. Noncondensables are defined as any gas that will not condense under temperatures and pressures present during operation of an air conditioning system. Noncondensables and water vapor combine with refrigerant to produce substances that corrode copper piping and compressor parts.

⚠ IMPORTANT

Use a thermocouple or thermistor electronic vacuum gauge that is calibrated in microns. Use an instrument that reads from 50 microns to at least 23,000 microns.

- 1 - Connect the manifold gauge set to the service valve ports as follows:
 - low pressure gauge to *vapor* line service valve
 - high pressure gauge to *liquid* line service valve

2 - Connect micron gauge.

3 - Connect the vacuum pump (with vacuum gauge) to the center port of the manifold gauge set.

4 - Open both manifold valves and start vacuum pump.

5 - Evacuate the line set and indoor unit to an **absolute pressure** of 23,000 microns (29.01 inches of mercury). During the early stages of evacuation, it is desirable to close the manifold gauge valve at least once to determine if there is a rapid rise in **absolute pressure**. A rapid rise in pressure indicates a relatively large leak. If this occurs, repeat the leak testing procedure.

NOTE - The term absolute pressure means the total actual pressure within a given volume or system, above the absolute zero of pressure. Absolute pressure in a vacuum is equal to atmospheric pressure minus vacuum pressure.

6 - When the absolute pressure reaches 23,000 microns (29.01 inches of mercury), close the manifold gauge valves, turn off the vacuum pump and disconnect the manifold gauge center port hose from vacuum pump. Attach the manifold center port hose to a nitrogen cylinder with pressure regulator set to 150 psig (1034 kPa) and purge the hose. Open the manifold gauge valves to break the vacuum in the line set and indoor unit. Close the manifold gauge valves.

⚠ WARNING

Danger of Equipment Damage. Avoid deep vacuum operation. Do not use compressors to evacuate a system. Extremely low vacuums can cause internal arcing and compressor failure. Damage caused by deep vacuum operation will void warranty.

7 - Shut off the nitrogen cylinder and remove the manifold gauge hose from the cylinder. Open the manifold gauge valves to release the nitrogen from the line set and indoor unit.

8 - Reconnect the manifold gauge to the vacuum pump, turn the pump on, and continue to evacuate the line set and indoor unit until the absolute pressure does not rise above 500 microns (29.9 inches of mercury) within a 20-minute period after shutting off the vacuum pump and closing the manifold gauge valves.

9 - When the absolute pressure requirement above has been met, disconnect the manifold hose from the vacuum pump and connect it to an upright cylinder of R410A refrigerant. Open the manifold gauge valves to break the vacuum from 1 to 2 psig positive pressure in the line set and indoor unit. Close manifold gauge valves and shut off the R410A cylinder and remove the manifold gauge set.

C-Charging

This system is charged with R410A refrigerant which operates at much higher pressures than R22. The check/expansion valve provided with the unit is approved for use with R410A. Do not replace it with a valve designed for use with R22. This unit is NOT approved for use with coils which include metering orifices or capillary tubes.

Processing Procedure

The unit is factory-charged with the amount of R410A refrigerant indicated on the unit rating plate. This charge is based on a matching indoor coil and outdoor coil with a 15 foot (4.6m) line set. For varying lengths of line set, refer to table 9 for refrigerant charge adjustment. .

⚠ IMPORTANT

Mineral oils are not compatible with R410A. If oil must be added, it must be a polyol ester oil.

It is desirable to charge the system in the cooling cycle if weather conditions permit. However, if the unit must be charged in the heating season, one of the following procedures must be followed to ensure proper system charge.

Weighing in the Charge TXV Systems – Outdoor Temp. < 65°F (18°C)

If the system is void of refrigerant, or if the outdoor ambient temperature is cool, the refrigerant charge should be weighed into the unit. Do this after any leaks have been repaired.

- 1 - Recover the refrigerant from the unit.
- 2 - Conduct a leak check, then evacuate as previously outlined.
- 3 - Weigh in the unit nameplate charge.

If weighing facilities are not available or if you are charging the unit during warm weather, follow one of the other procedures outlined below.

Subcooling Method Outdoor Temp. < 65°F (18°C)

When the outdoor ambient temperature is below 65°F (18°C), use the subcooling method to charge the unit. It may be necessary to restrict the air flow through the outdoor coil to achieve pressures in the 325-375 psig (2240-2585 kPa) range. These higher pressures are necessary for checking the charge. Block equal sections of air intake panels and move obstructions sideways until the liquid pressure is in the 325-375 psig (2240-2585 kPa) range. Figure 25 shows a four sided unit for example..

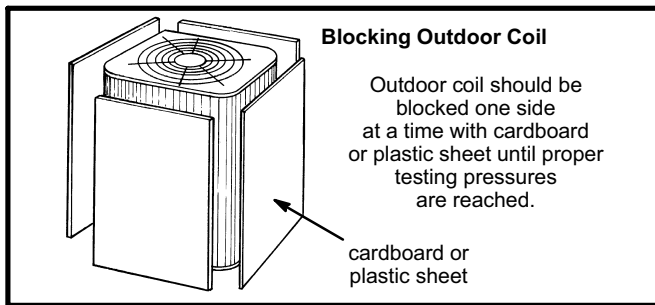

FIGURE 25

- 1 - With the manifold gauge hose still on the liquid service port and the unit operating stably, use a digital thermometer to record the liquid line temperature.
- 2 - At the same time, record the liquid line pressure reading.
- 3 - Use a temperature/pressure chart for R410A to determine the saturation temperature for the liquid line pressure reading. See table 14.
- 4 - Subtract the liquid line temperature from the saturation temperature (according to the chart) to determine subcooling. **(Saturation temperature - Liquid line temperature = Subcooling)**
- 5 - Compare the subcooling value with those in table 10. If subcooling is greater than shown, recover some refrigerant. If subcooling is less than shown, add some refrigerant. Be aware of the R410A refrigerant cylinder. It will be light maroon-colored. Refrigerant should be added through the vapor line valve in the liquid state. **Some R410A cylinders are equipped with a dip tube that allows you to draw liquid refrigerant from the bottom of the cylinder without turning the cylinder upside-down. The cylinder will be marked if it is equipped with a dip tube.**

TABLE 10
2nd stage High Capacity

Model Number	Subcooling Values Conversion Temp. - Liquid Line Temp. °F (°C)
HPXA19-024	11.0 ± 1 (6 ± .5)
HPXA19-036	8.5 ± 1 (4.7 ± .5)
HPXA19-038	10.5 ± 1 (5.8 ± .5)
HPXA19-048	7.5 ± 1 (4.1 ± .5)
HPXA19-060	7.0 ± 1 (3.9 ± .5)

Charging Using Normal Operating Pressures and the Approach Method

Outdoor Temp. ≥ 65°F (18°C)

The following procedure is intended as a general guide and is for use on expansion valve systems only. For best results, indoor temperature should be 70°F (21°C) to 80°F (26°C). Monitor system pressures while charging.

- 1 - Record outdoor ambient temperature using a digital thermometer.
- 2 - Attach high pressure gauge set and operate unit for several minutes to allow system pressures to stabilize.
- 3 - Compare stabilized pressures with those provided in tables 12 and 13, "Normal Operating Pressures." Minor variations in these pressures may be expected due to differences in installations. Significant differences could mean that the system is not properly charged or that a problem exists with some component in the system. Pressures higher than those listed indicate that the system is overcharged. Pressures lower than those listed indicate that the system is undercharged. Verify adjusted charge using the approach method.

Approach Method

- 4 - Use the same digital thermometer used to check outdoor ambient temperature to check liquid line temperature. Verify the unit charge using the approach method.
- 5 - The difference between the ambient and liquid temperatures should match values given in table 11. If the values don't agree with the those in table 11, add refrigerant to lower the approach temperature or recover refrigerant from the system to increase the approach temperature.

TABLE 11
2nd Stage High Capacity

Model Number	Approach Temperature Liquid Line Temp. - Outdoor Ambient °F (°C)
HPXA19-024	4.0 ± 1 (2.2 ± .5)
HPXA19-036	7.0 ± 1 (3.9 ± .5)
HPXA19-038	4.0 ± 1 (2.2 ± .5)
HPXA19-048	8.0 ± 1 (4.4 ± .5)
HPXA19-060	10.0 ± 1 (5.6 ± .5)

! IMPORTANT

Use table 12 and table 13 as a general guide when performing maintenance checks. This is not a procedure for charging the unit (Refer to Charging/Checking Charge section). Minor variations in these pressures may be expected due to differences in installations. Significant differences could mean that the system is not properly charged or that a problem exists with some component in the system.

**TABLE 12
NORMAL OPERATING PRESSURES
COOLING OPERATION
(Liquid ±10 and Vapor ±5 psig)**

First Stage (Low Capacity)										
Outdoor Coil Entering Air Temp. °F (°C)	HPXA19-024		HPXA19-036		HPXA19-038		HPXA19-048		HPXA19-060	
	Liquid	Vapor	Liquid	Vapor	Liquid	Vapor	Liquid	Vapor	Liquid	Vapor
65 (18.3)	217	143	227	142	222	142	222	140	225	140
75 (23.9)	250	145	262	145	255	145	258	143	259	142
85 (29.4)	291	147	305	146	295	146	298	145	293	146
95 (35.0)	336	149	352	148	343	148	343	147	356	147
105 (40.6)	386	151	403	152	390	153	402	147	408	147
115 (49.0)	440	153	458	155	446	156	452	152	455	151
Second Stage (High Capacity)										
Outdoor Coil Entering Air Temp. °F (°C)	HPXA19-024		HPXA19-036		HPXA19-038		HPXA19-048		HPXA19-060	
	Liquid	Vapor	Liquid	Vapor	Liquid	Vapor	Liquid	Vapor	Liquid	Vapor
65 (18.3)	222	143	244	136	231	133	232	134	249	126
75 (23.9)	256	145	282	139	263	139	266	136	289	134
85 (29.4)	302	145	325	142	305	142	309	139	330	140
95 (35.0)	349	147	377	144	354	145	359	142	378	143
105 (40.6)	403	149	428	146	403	147	410	144	433	146
115 (49.0)	464	152	488	148	461	149	468	147	492	149

**TABLE 13
NORMAL OPERATING PRESSURES
HEATING OPERATION
(Liquid ±10 and Vapor ±5 psig)**

First Stage (Low Capacity)										
Outdoor Coil Entering Air	HPXA19-024		HPXA19-036		HPXA19-038		HPXA19-048		HPXA19-060	
	Liquid	Vapor	Liquid	Vapor	Liquid	Vapor	Liquid	Vapor	Liquid	Vapor
40 (4.4)	321	99	296	95	308	97	315	97	319	93
50 (10)	340	120	310	112	323	116	330	114	335	111
Second Stage (High Capacity)										
Outdoor Coil Entering Air Temp.	HPXA19-024		HPXA19-036		HPXA19-038		HPXA19-048		HPXA19-060	
	Liquid	Vapor	Liquid	Vapor	Liquid	Vapor	Liquid	Vapor	Liquid	Vapor
20 (-7.0)	273	68	277	60	288	59	294	60	300	57
30 (-1.0)	296	80	296	74	308	74	303	75	312	70
40 (4.4)	321	95	321	88	316	90	314	90	323	83
50 (10)	341	115	341	104	330	108	325	106	339	97

**Table 14
R410A Temperature/Pressure Chart**

Temperature °F	Pressure Psig	Temperature °F	Pressure Psig	Temperature °F	Pressure Psig	Temperature °F	Pressure Psig
32	100.8	63	178.5	94	290.8	125	445.9
33	102.9	64	181.6	95	295.1	126	451.8
34	105.0	65	184.3	96	299.4	127	457.6
35	107.1	66	187.7	97	303.8	128	463.5
36	109.2	67	190.9	98	308.2	129	469.5
37	111.4	68	194.1	99	312.7	130	475.6
38	113.6	69	197.3	100	317.2	131	481.6
39	115.8	70	200.6	101	321.8	132	487.8
40	118.0	71	203.9	102	326.4	133	494.0
41	120.3	72	207.2	103	331.0	134	500.2
42	122.6	73	210.6	104	335.7	135	506.5
43	125.0	74	214.0	105	340.5	136	512.9
44	127.3	75	217.4	106	345.3	137	519.3
45	129.7	76	220.9	107	350.1	138	525.8
46	132.2	77	224.4	108	355.0	139	532.4
47	134.6	78	228.0	109	360.0	140	539.0
48	137.1	79	231.6	110	365.0	141	545.6
49	139.6	80	235.3	111	370.0	142	552.3
50	142.2	81	239.0	112	375.1	143	559.1
51	144.8	82	242.7	113	380.2	144	565.9
52	147.4	83	246.5	114	385.4	145	572.8
53	150.1	84	250.3	115	390.7	146	579.8
54	152.8	85	254.1	116	396.0	147	586.8
55	155.5	86	258.0	117	401.3	148	593.8
56	158.2	87	262.0	118	406.7	149	601.0
57	161.0	88	266.0	119	412.2	150	608.1
58	163.9	89	270.0	120	417.7	151	615.4
59	166.7	90	274.1	121	423.2	152	622.7
60	169.6	91	278.2	122	428.8	153	630.1
61	172.6	92	282.3	123	434.5	154	637.5
62	195.5	93	286.5	124	440.2	155	645.0

V-SERVICE AND RECOVERY

⚠ WARNING

Polyol ester (POE) oils used with R410A refrigerant absorb moisture very quickly. It is very important that the refrigerant system be kept closed as much as possible. **DO NOT** remove line set caps or service valve stub caps until you are ready to make connections.

⚠ IMPORTANT

Use recovery machine rated for R410 refrigerant.

If the HPXA19 system must be opened for any kind of service, such as compressor or filter drier replacement, you must take extra precautions to prevent moisture from entering the system. The following steps will help to minimize the amount of moisture that enters the system during recovery of R410A.

- 1 - Use a regulator-equipped nitrogen cylinder to break the system vacuum. Do not exceed 5 psi. The dry nitrogen will fill the system, and will help purge any moisture.
- 2 - Remove the faulty component and quickly seal the system (using tape or some other means) to prevent additional moisture from entering the system.
- 3 - Do not remove the tape until you are ready to install new component. Quickly install the replacement component.
- 4 - Evacuate the system to remove any moisture and other non-condensables.

The HPXA19 system MUST be checked for moisture any time the sealed system is opened.

Any moisture not absorbed by the polyol ester oil can be removed by triple evacuation. Moisture that has been absorbed by the compressor oil can be removed by replacing the filter drier.

⚠ IMPORTANT

Evacuation of system only will not remove moisture from oil. Filter drier must be replaced to eliminate moisture from POE oil.

VI-MAINTENANCE

⚠ WARNING



Electric shock hazard. Can cause injury or death. Before attempting to perform any service or maintenance, turn the electrical power to unit OFF at disconnect switch(es). Unit may have multiple power supplies.

Maintenance and service must be performed by a qualified installer or service agency. At the beginning of each cooling or heating season, the system should be checked as follows:

Outdoor Unit

- 1 - Clean and inspect outdoor coil (may be flushed with a water hose). Ensure power is off before cleaning.
- 2 - Outdoor unit fan motor is prelubricated and sealed. No further lubrication is needed.
- 3 - Visually inspect all connecting lines, joints and coils for evidence of oil leaks.
- 4 - Check all wiring for loose connections.
- 5 - Check for correct voltage at unit (unit operating).
- 6 - Check amp-draw on outdoor fan motor and compressor (high and low capacity).
- 7 - Inspect drain holes in coil compartment base and clean if necessary.

NOTE - If owner complains of insufficient cooling, the unit should be gauged and refrigerant charge checked. Refer to section on refrigerant charging in this instruction.

Indoor Coil

- 1 - Clean coil if necessary.
- 2 - Check connecting lines, joints and coil for evidence of oil leaks.
- 3 - Check condensate line and clean if necessary.

Indoor Unit

- 1 - Clean or change filters.
- 2 - Lennox blower motors are prelubricated and permanently sealed. No more lubrication is needed.
- 3 - Adjust blower speed for cooling. Measure the pressure drop over the coil to determine the correct blower CFM. Refer to the unit information service manual for pressure drop tables and procedure.
- 4 - *Belt Drive Blowers* - Check belt for wear and proper tension.
- 5 - Check all wiring for loose connections.
- 6 - Check for correct voltage at unit.
- 7 - Check amp-draw on blower motor.

VII-DIAGRAM / OPERATING SEQUENCE

HPXA19-024, 036, -048 & -060

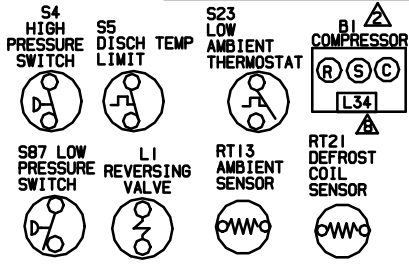
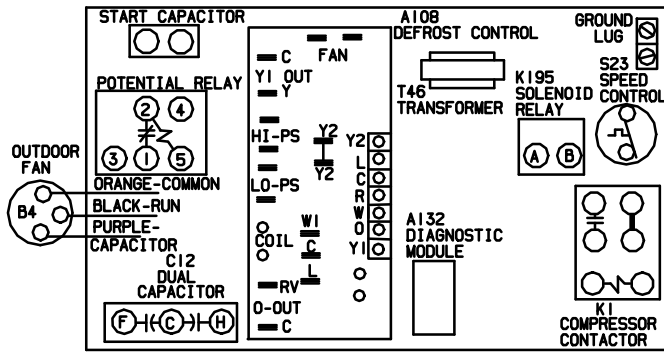

NOTE- FOR USE WITH COPPER CONDUCTORS ONLY. REFER TO UNIT RATING PLATE FOR MINIMUM CIRCUIT AMPACITY AND MAXIMUM OVER-CURRENT PROTECTION SIZE

REFER TO COMPRESSOR IN UNIT FOR ACTUAL TERMINAL ARRANGEMENT.

WARNING- ELECTRIC SHOCK HAZARD, CAN CAUSE INJURY OR DEATH. UNIT MUST BE GROUNDED IN ACCORDANCE WITH NATIONAL AND LOCAL CODES.

← DENOTES OPTIONAL COMPONENTS
 — LINE VOLTAGE FIELD INSTALLED
 - - - CLASS II VOLTAGE FIELD INSTALLED

- ▲ REMOVE JUMPER FOR TWO STAGE COOL
- ▲ RT14 SENSOR, OUTDOOR TEMP (OPTIONAL)
- ▲ S23 CLOSES AT LOW AMBIENT TEMPERATURES TO OPERATE SECOND STAGE COMPRESSOR ON HEATING
- ▲ S11 AND K58 ARE OPTIONAL LOW AMBIENT CONTROLS
- ▲ L34 SECOND STAGE SOLENOID IS LOCATED IN COMPRESSOR. COIL IS 24VDC, DO NOT CONNECT 24VAC TO COIL TERMINALS.
- ▲ K31 AND C7 ARE USED ON 024 UNITS ONLY

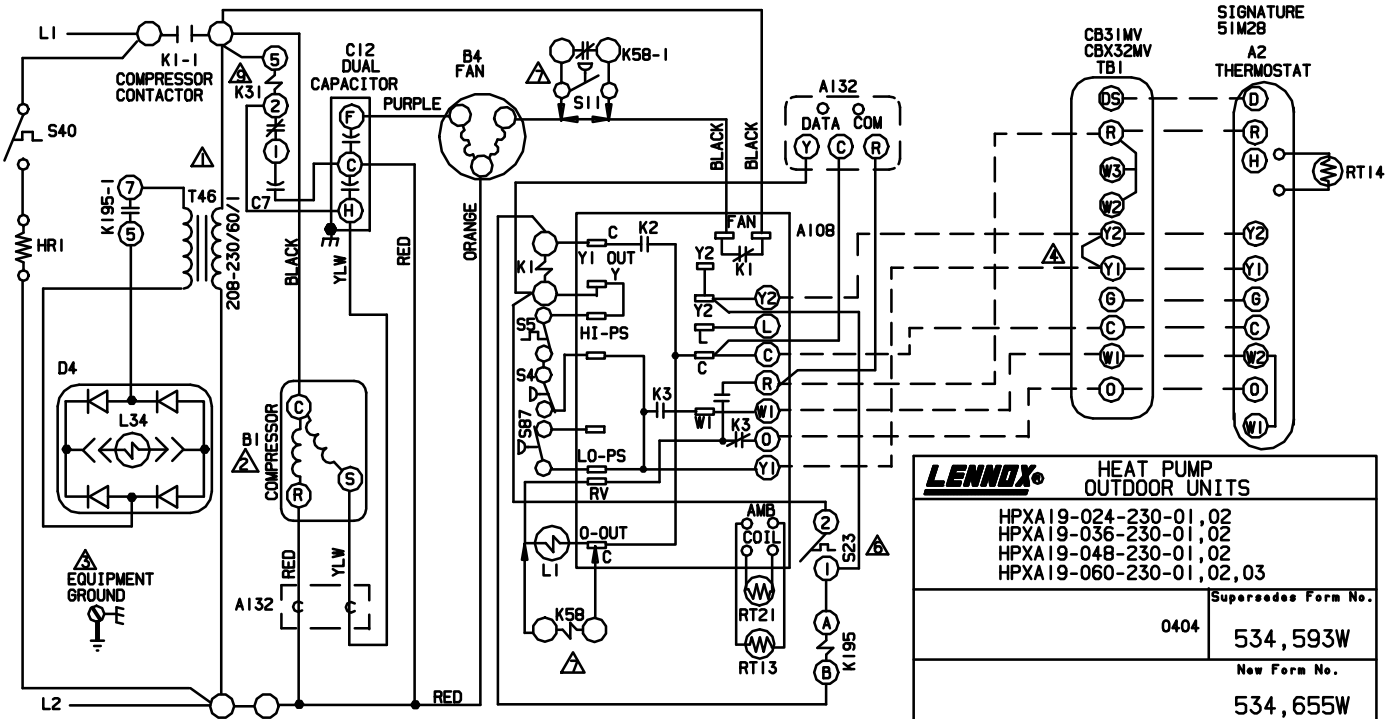

LENNOX HEAT PUMP OUTDOOR UNITS	
HPXA19-024-230-01, 02 HPXA19-036-230-01, 02 HPXA19-048-230-01, 02 HPXA19-060-230-01, 02, 03	
0404	Supersedes Form No. 534, 593W
New Form No. 534, 655W	

©2004 Lennox Industries Inc. Litho U.S.A.

Sequence of Operation HPXA19-024/060

First Stage Cool (low capacity)

Transformer from indoor unit supplies 24VAC power to the thermostat and outdoor unit controls.

- 1- Internal wiring energizes terminal O by cooling mode selection, energizing the reversing valve. Cooling demand initiates at Y1 in the thermostat.
- 2- 24VAC passes through high pressure switch S4 and discharge thermostat switch S5 energizing compressor contactor K1.
HPXA19-024 - Compressor begins start up. Relay K31 remains closed during start up and capacitor C7 remains in the circuit. As compressor speeds up K31 is energized, de-energizing capacitor C7.
- 3- K1-1 N.O. closes energizing compressor B1 and outdoor fan motor B4. Transformer T46 is also energized.
- 4- Solenoid L34 is NOT energized. The slider ring remains open limiting compressor to low capacity.

Second Stage Cool (high capacity)

- 5- Second stage thermostat demand energizes solenoid relay K195. K195-1 closes sending voltage to rectifier plug D4. D4 converts the AC voltage to DC voltage and energizes L34 unloader solenoid. L34 then closes the slider ring, allowing the compressor to operate at high capacity.

Heating

A- Ambient temperature ABOVE S23 low ambient thermostat setting. S23 remains open.

- 1- Internal wiring de-energizes terminal O by heating mode selection, de-energizing the reversing valve. Heating demand initiates at Y1.
- 2- 24VAC passes through high pressure switch S4 and discharge thermostat switch S5 energizing compressor contactor K1.
- 3- K1-1 N.O. closes, energizing compressor, outdoor fan motor and transformer T46.
- 4- Solenoid L34 is NOT energized. The slider ring remains open limiting compressor to low capacity.

B- Ambient temperature BELOW S23 low ambient thermostat setting. S23 closes shunting Y1 and Y2.

- 1- Internal wiring de-energizes terminal O by heating mode selection, de-energizing the reversing valve. Thermostat calls for heating demand.
- 2- 24VAC passes through high pressure switch S4 and discharge thermostat switch S5 energizing compressor contactor K1.
- 3- K1-1 N.O. closes, energizing compressor, outdoor fan motor and transformer T46.
- 4- Heat demand energizes solenoid relay K195. K195-1 closes sending voltage to rectifier plug D4. D4 converts the AC voltage to DC voltage and energizes L34 unloader solenoid. L34 then closes the slider ring, allowing the compressor to operate at full capacity.

Defrost Mode

When a defrost cycle is initiated, the control energizes the reversing valve solenoid and turns off the condenser fan. The control will also put 24VAC on the "W1" (auxiliary heat) line. The unit will stay in this mode until either the coil sensor temperature is above the selected termination temperature, the defrost time of 14 minutes has been completed, or the room thermostat demand cycle has been satisfied. (If the temperature select shunt is not installed, the default termination temperature will be 100°F.) If the room thermostat demand cycle terminates the cycle, the defrost cycle will be held until the next room thermostat demand cycle. If the coil sensor temperature is still below the selected termination temperature, the control will continue the defrost cycle until the cycle is terminated in one of the methods mentioned above. If a defrost is terminated by time and the coil temperature did not remain above 35°F (2°C) for 4 minutes the control will go to the 34-minute Time/Temperature mode.

HPXA19-038 with Variable Speed Motor

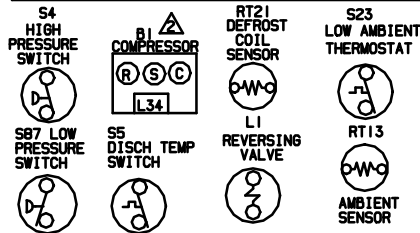
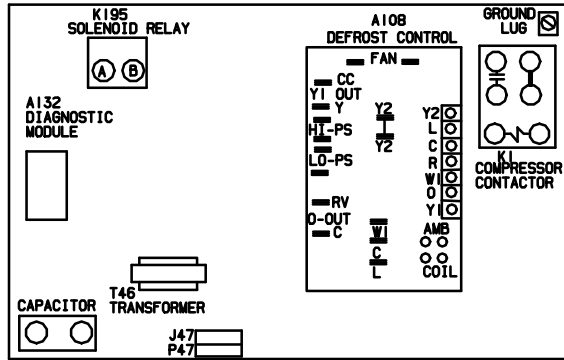

NOTE- FOR USE WITH COPPER CONDUCTORS ONLY. REFER TO UNIT RATING PLATE FOR MINIMUM CIRCUIT AMPACITY AND MAXIMUM OVER-CURRENT PROTECTION SIZE

REFER TO COMPRESSOR IN UNIT FOR ACTUAL TERMINAL ARRANGEMENT.

WARNING- ELECTRIC SHOCK HAZARD, CAN CAUSE INJURY OR DEATH. UNIT MUST BE GROUNDED IN ACCORDANCE WITH NATIONAL AND LOCAL CODES.

REMOVE JUMPER FOR TWO STAGE COOL

RT14 SENSOR, OUTDOOR TEMP (OPTIONAL)

S23 CLOSES AT LOW AMBIENT TEMPERATURES TO OPERATE SECOND STAGE COMPRESSOR ON HEATING

L34 SOLENOID IS LOCATED IN COMPRESSOR. COIL IS 24VDC. DO NOT CONNECT 24VAC TO COIL TERMINALS

S11, K159 AND K58 ARE OPTIONAL LOW AMBIENT CONTROLS

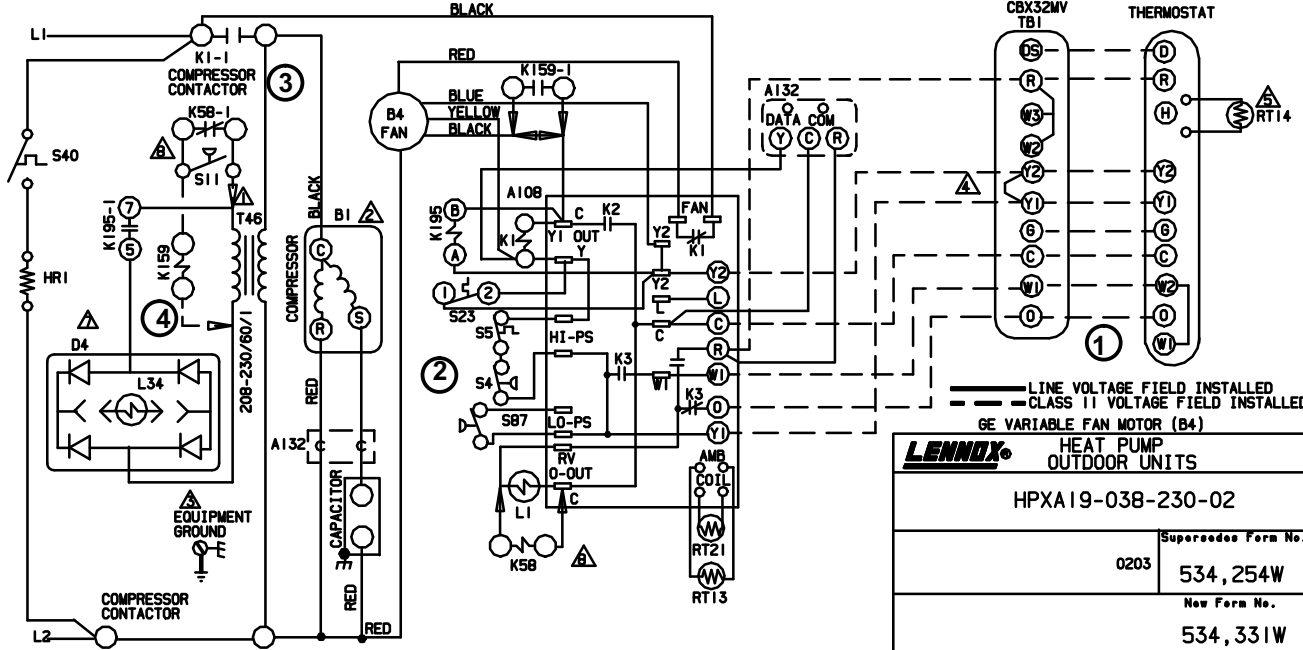

©2005 Lennox Industries Inc. Litho U.S.A.

Sequence of Operation HPXA19-038

First Stage Cool (low capacity)

Transformer from indoor unit supplies 24VAC power to the thermostat and outdoor unit controls.

- 1- Internal wiring energizes terminal O by cooling mode selection, energizing the reversing valve. Cooling demand initiates at Y1 in the thermostat.
- 2- 24VAC passes through high pressure switch S4 and discharge thermostat switch S5 energizing compressor contactor K1.
- 3- K1-1 N.O. closes energizing compressor B1, transformer T46 and outdoor fan motor B4. Variable speed condenser fan motor operates on low speed (yellow tap).
- 4- Solenoid L34 is NOT energized. The slider ring remains open limiting compressor to low capacity.

Second Stage Cool (high Capacity)

- 5- Second stage thermostat demand energizes solenoid relay K195. K195-1 closes sending voltage to rectifier plug D4. D4 converts the AC voltage to DC voltage and energizes L34 unloader solenoid. L34 then closes the slider ring, allowing the compressor to operate at full capacity. Variable speed condenser fan motor operates on high speed (blue tap).

Heating

A- Ambient temperature ABOVE S23 low ambient thermostat setting. S23 remains open.

- 1- Internal wiring de-energizes terminal O by heating mode selection, de-energizing the reversing valve. Heating demand initiates at Y1.
- 2- 24VAC passes through high pressure switch S4 and discharge thermostat switch S5 energizing compressor contactor K1.
- 3- K1-1 N.O. closes, energizing compressor B1, transformer T46 and outdoor fan motor B4. Variable speed condenser fan motor operates on low speed (yellow tap).
- 4- Solenoid L34 is NOT energized. The slider ring remains open limiting compressor to low capacity.

B- Ambient temperature BELOW S23 low ambient setting. S23 closes shunting Y1 and Y2.

- 1- Internal wiring de-energizes terminal O by heating mode selection, de-energizing the reversing valve. Indoor thermostat calls for heating demand.
- 2- 24VAC passes through high pressure switch S4 and discharge thermostat switch S5 energizing compressor contactor K1.
- 3- K1-1 N.O. closes, energizing compressor B1, transformer T46 and outdoor fan motor B4. Variable speed condenser fan motor operates on high speed (blue tap).
- 4- Heat demand energizes solenoid relay K195. K195-1 closes sending voltage to rectifier plug D4. D4 converts the AC voltage to DC voltage and energizes L34 unloader solenoid. L34 then closes the slider ring, allowing the compressor to operate at full capacity.

Defrost Mode

When a defrost cycle is initiated, the control energizes the reversing valve solenoid and turns off the condenser fan. The control will also put 24VAC on the "W1" (auxiliary heat) line. The unit will stay in this mode until either the coil sensor temperature is above the selected termination temperature, the defrost time of 14 minutes has been completed, or the room thermostat demand cycle has been satisfied. (If the temperature select shunt is not installed, the default termination temperature will be 100°F.) If the room thermostat demand cycle terminates the cycle, the defrost cycle will be held until the next room thermostat demand cycle. If the coil sensor temperature is still below the selected termination temperature, the control will continue the defrost cycle until the cycle is terminated in one of the methods mentioned above. If a defrost is terminated by time and the coil temperature did not remain above 35°F (2°C) for 4 minutes, the control will go to the 34-minute Time/Temperature mode.