

HORIZONTAL ECONOMIZERS

Z1ECON33 (14D93) HIGH PERFORMANCE ECONOMIZER

INSTALLATION INSTRUCTIONS FOR ECONOMIZERS USED WITH ZC,ZG,ZH 036, 048, 060, 072, 074 UNITS

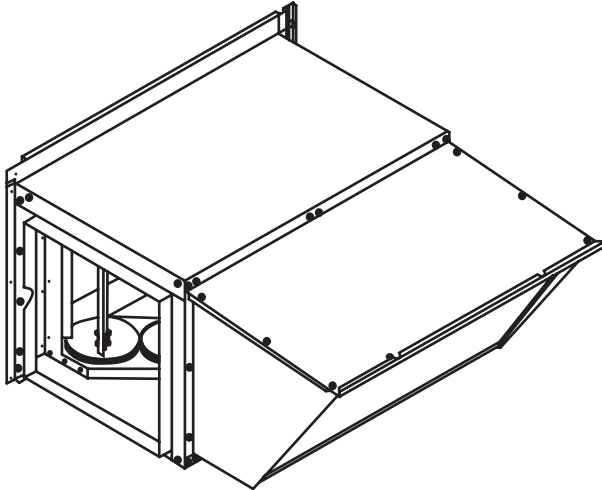

Figure 1

Application

The Z1ECON33 (14D93) high performance economizer is used with ZC, ZG, ZH 036, 048, 060, 072, 074 units in horizontal air discharge applications. Economizer dampers will modulate to maintain 55°F (31°C) supply air when outdoor air is suitable. The mixed air temperature sensor measures the supply air sensible temperature.

An outdoor air sensor is used to determine whether outdoor air is suitable for free cooling. The outdoor air sensor is factory-installed in all economizers. The high performance economizer is equipped with W7220 control module A6. The default OA temperature sensor or high limit sensor (RT26) is a CEC approved, California Title 24 fixed dry bulb device.

See Table 1 for outdoor and return air (OA and RA) sensor options. Refer to manufacturer's instructions provided for more detail.

TABLE 1

Sensors	Dampers modulate to maintain 55°F mixed air (R1) when:
Single OA Sensible DEFAULT - approved for CA Title 24	OA temperature (RT26) is lower than free cooling setpoint
Single OA Enthalpy Not approved for CA Title 24	OA temperature and humidity (A7) is lower than free cooling setpoint
Differential Enthalpy - 1 in OA & 1 in RA Not approved for CA Title 24	OA temperature and humidity (A7) is lower than RA temperature and humidity (A62).
IAQ Sensor	CO ₂ sensed (A63) is higher than CO ₂ setpoint

INDOOR AIR QUALITY SENSOR

An IAQ sensor is used when demand control ventilation (DCV) is specified. Damper minimum position can be set lower than traditional minimum air requirements resulting in cost savings. The IAQ sensor allows the economizer control module to open dampers to traditional ventilation requirements as room occupancy (CO₂) increases.

For proper operation, the IAQ sensor must provide a 2-10VDC, 100 ohm impedance signal. Connect sensors to the green IAQ leads provided on the economizer control module in the filter section as shown in Figure 9.

Shipping and Packing List

Package 1 of 1 contains:

- 1 - Economizer damper assembly
 - 1 - Outdoor air damper
 - 1 - Return air damper
 - 1 - Gravity exhaust damper
 - 1 - Return Air Cover
 - 1 - Economizer actuator
 - 1 - Economizer control module
 - 1 - Outdoor air temperature sensor
- 1 - Hardware bag
 - 1 - Mixed air sensor
 - 3 - #10-14 x 3/4" screws with washer
 - 11 - #10-16 x 5/8" screws
- 1 - Side economizer panel
- 1 - Bottom return air cover panel

Order Of Installation

- Bottom return air cover
- Economizer
- Mixed air sensor
- Optional OA and RA sensors
- Power Exhaust fans (optional)
- Side economizer panel



WARNING

Improper installation, adjustment, alteration, service or maintenance can cause property damage, personal injury or loss of life. Installation and service must be performed by a qualified installer, service agency or the gas supplier



CAUTION

Danger of sharp metallic edges. Can cause injury. Take care when servicing unit to avoid accidental contact with sharp edges.

Install Economizer

1. Disconnect all power sources to the unit
2. Remove the following panels from the unit;
 - Filter door panel
 - Return chamber panel
 - Indoor fan panel
3. Locate return air cover included in kit. Place a bead of silicone sealant on the underside of the return air cover flanges. Position the cover over the down flow return air opening. (See Fig. 3.) Secure covers with self-drilling screw in at least 4 places.

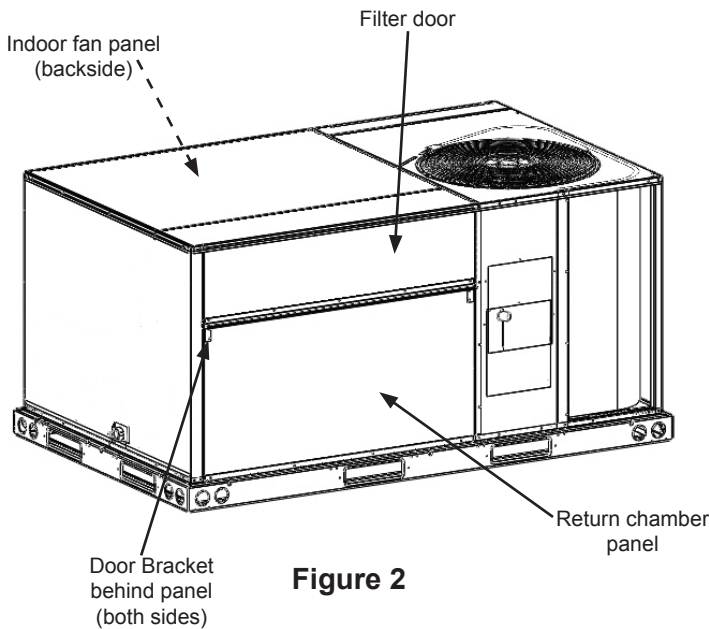

Figure 2

4. Install damper assembly on to unit where return chamber panel was. Economizer will sit outside of unit, and will rest on base rail. (See Fig. 4.)
5. Screw left side flange on economizer to HVAC unit using provided (3) #10-14 x 3/4" screws with washer.
6. Align the holes in the base flange of the economizer into the holes in the base rail of the HVAC unit. Secure in place using (5) #10-16 x 5/8" screws.
7. **Horizontal Economizer module is not entirely supported by fastening methods to HVAC unit. Field provided support on outer edge of economizer is required.**
8. Install field supplied horizontal return duct. Return duct must be 16 1/2" x 16 1/2". Screw to economizer duct flanges. Caulk or gasket seam to ensure water tight seal. See Fig. 6.

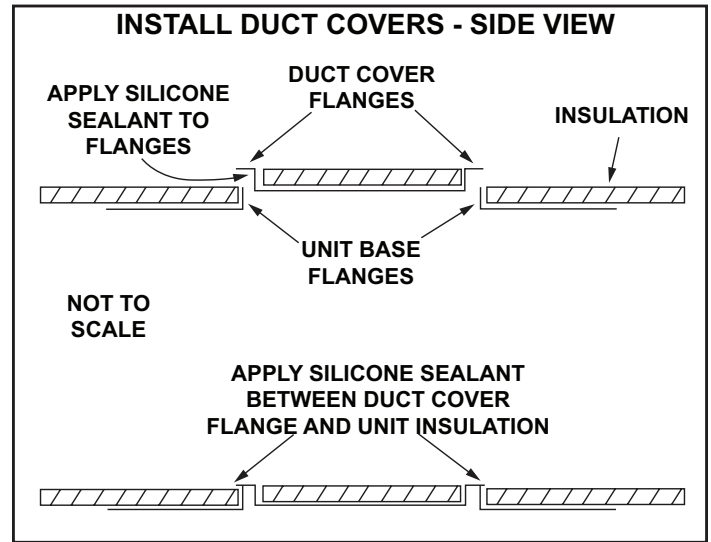

Figure 3

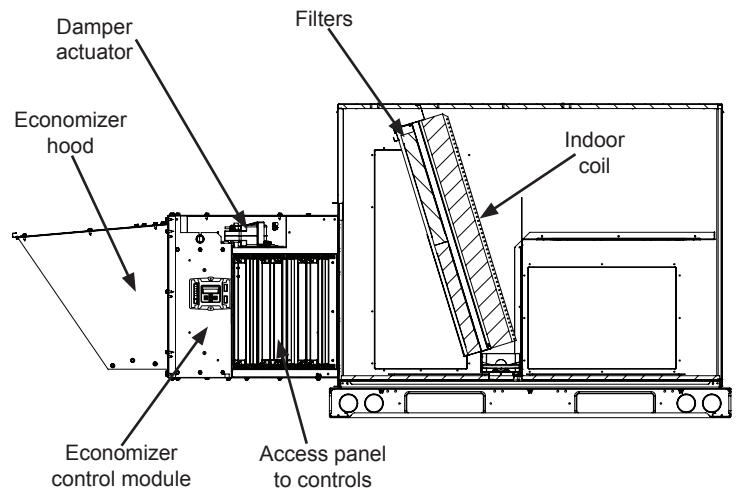

Figure 4

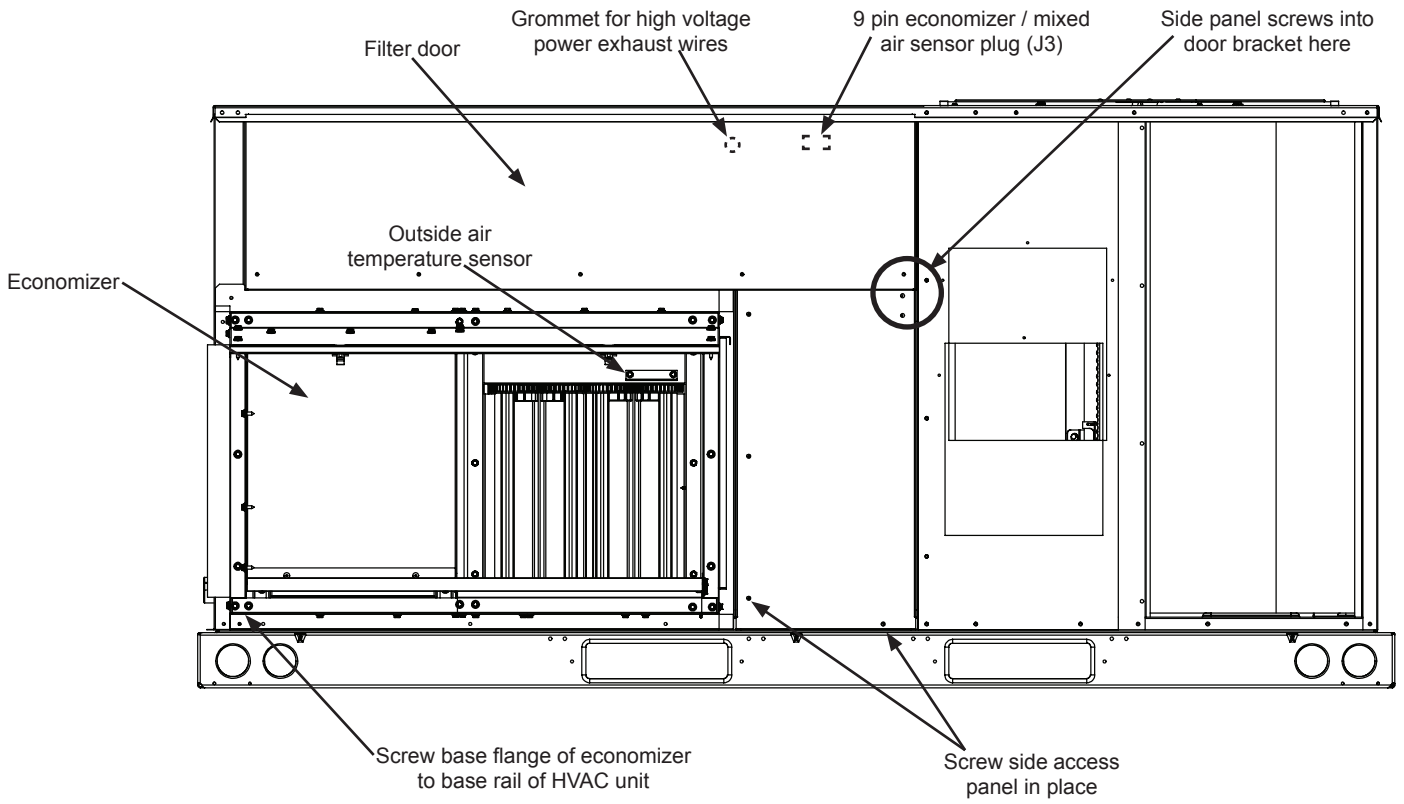

Figure 5

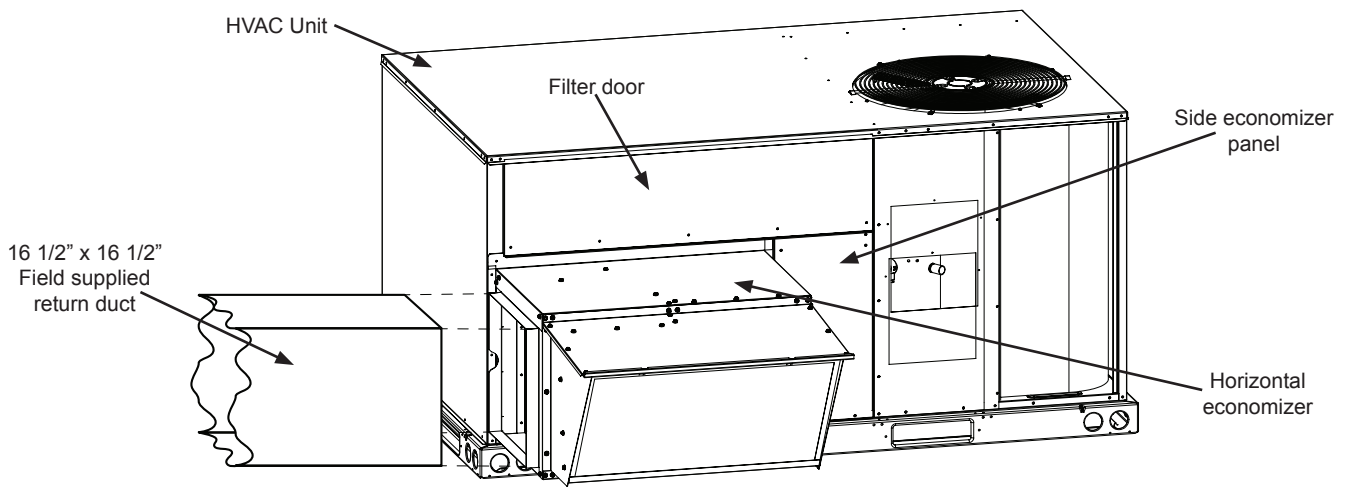

Figure 6

Economizer Wiring

1. Locate 9-pin J3 economizer jack harness seated in upper right panel inside filter compartment. Disconnect P3 jumper plug from J3 and retain jumper plug for future troubleshooting. Connect 9-pin P4 economizer plug from economizer control module harness to J3 economizer jack. Secure P4 harness with push in wire tie from parts bag and insert it into the 1/4" hole on top of filter rack. Refer to figures 5 and 9.
2. Connect any optional sensors as shown in figure 9.
3. If optional power exhaust is installed, wire according to instructions provided with power exhaust.
4. Use wiring diagram provided in kit and affix over the economizer portion of the main unit diagram located on the inside of the control panel cover.

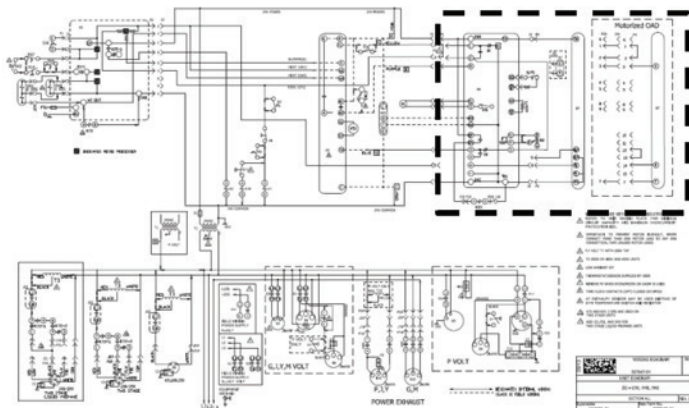

Figure 7

Install Mixed Air Sensor

1. Remove the mixed air sensor and mixed air sensor harness from the economizer parts bag.
2. Remove the panel covering the indoor fan. Locate the 2 mixed air sensors wires in the unit from plug J3. The mixed air sensor wire colors are green and violet. Attach these 2 wires to the mixed air sensor adapter wire harness provided in kit and connect the other end of the mixed air sensor.
3. Using the wire ties provided, tie the mixed air sensor to the wire bundle running down the wall of the inside of the blower deck.
4. Secure wires in place so they don't interfere with unit operation.
5. Replace the panel covering the indoor fan.

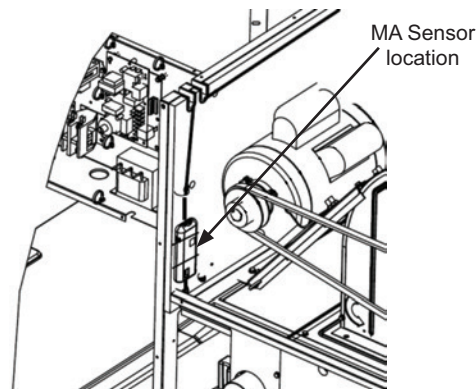

Figure 8

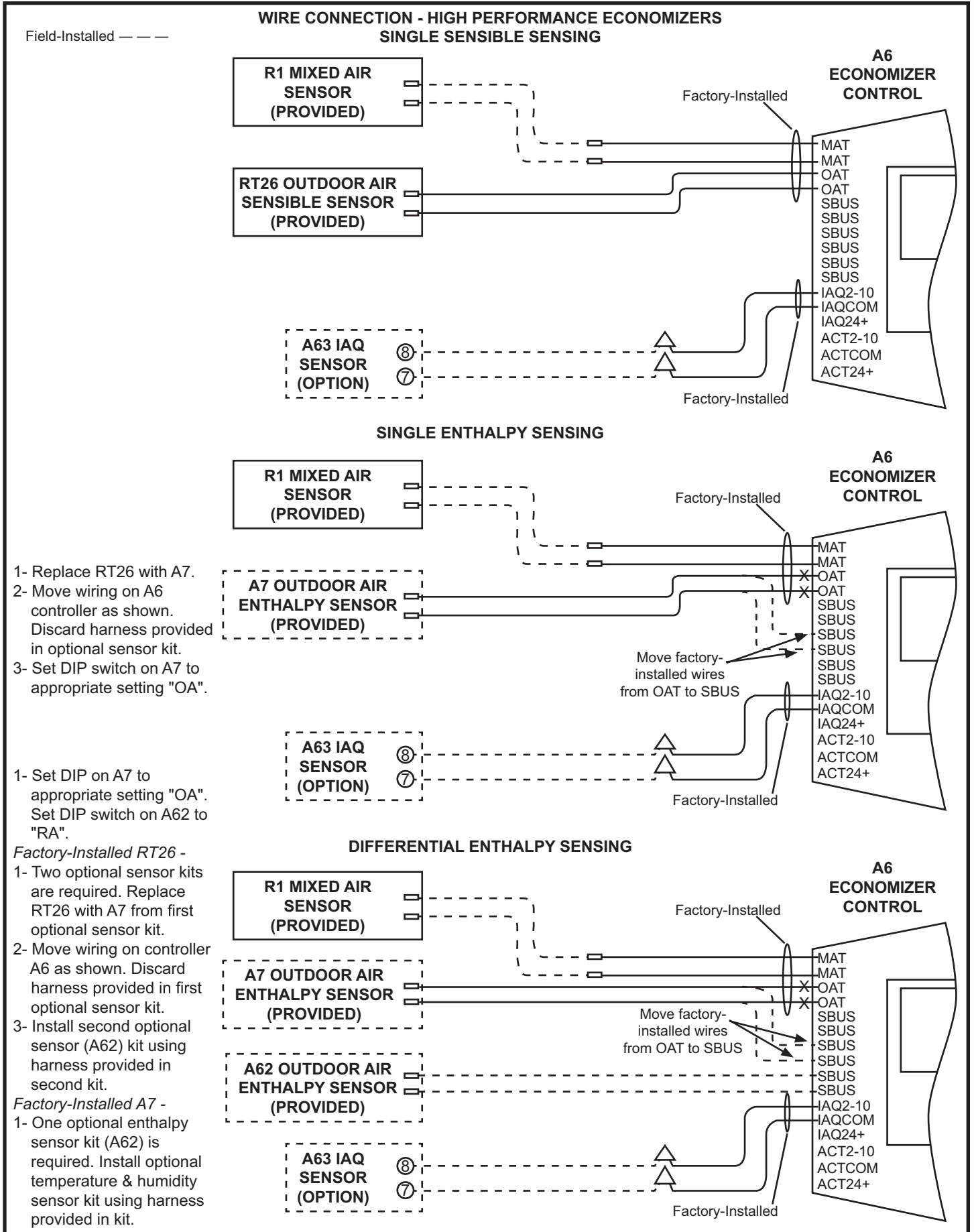

Figure 9

Economizer Side Panel

1. Before installing economizer side panel make all necessary job specific settings to the economizer control module, including minimum position setting.
2. Install side panel to the right side of hood, see figures 5 and 6. Screw panel to economizer on left side, and into door bracket on right side of panel.
3. Reinstall unit's filter access door.
4. Caulk all seams and gaps along sides and bottom of economizer and economizer side panel sheet metal. Allow time for caulk to cure prior to placing unit into operation.

Economizer Control Module

Note - The A6 economizer control will be in the "setup" mode for the first sixty minutes after powered. If a sensor for outdoor air or SBUS device (sensor, actuator) is disconnected during the set up mode, the A6 will not alarm that failure. The R1 mixed air sensor is a system "critical" sensor; if the mixed air sensor is removed during the set up mode, the A6 will alarm. After sixty minutes the A6 will change to operation mode and all components removed or failed will alarm in the operation mode.

INITIAL SETUP

A default program must be modified for proper operation in each application. See 'Setup and Configuration' section.

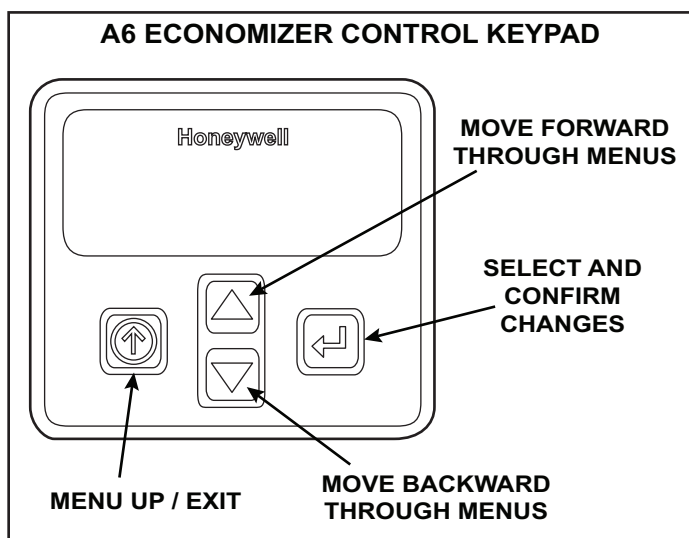

USING THE KEYPAD

Use the keypad as follows:

- Navigate to the desired menu.
- Press the button (enter) to display the first item in the currently displayed menu.
- Use the and buttons to scroll to the desired parameter.
- Press the enter button (enter) to display the value of the currently displayed item.

- Press the button to increase (change) the displayed parameter value.a
- Press the button to decrease (change) the displayed parameter value.a
- Press the enter button (enter) to accept the displayed value and store it in non-volatile RAM.
- CHANGE STORED displays.
- Press the button (enter) to return to the current menu parameter.
- Press the button (Menu Up/Exit) to return to the previous menu.

When values are displayed, pressing and holding the and button causes the display to automatically increment.

MENU STRUCTURE

The menus in display order are:

- STATUS
- SETPOINTS
- SYSTEM SETUP
- ADVANCED SETUP
- CHECKOUT
- ALARMS

For a complete list of parameters refer to the Honeywell installation manual provided in this kit.

IMPORTANT - Menu parameters will be different depending on each configuration. For example: if a DCV (CO2) sensor is not used, none of the DCV parameters will appear and only MIN POS will display. If CO2 sensor is used, the DCV SET, VENTMIN and VENTMAX will appear.

SETUP AND CONFIGURATION

Program the following parameters into the controller. Navigate to the specific menus to make the changes required.

IMPORTANT - During setup, the economizer control is live at all times.

The setup process uses a hierarchical structure.

Press the and arrow buttons to move forward and backward through the menus and press the button to select and confirm setup item changes.

In the SYSTEM SETUP Menu

INSTALL (MM/DD/YY) enter installation date

EQUIPMENT (CONV)

AUX2 IN (HEAT W1)

FAN SPEED (1SPEED)

FAN CFM () enter rooftop unit indoor blower CFM

AUX1 OUT (NONE) change to SYS if A6 controller is wired for remote alarm monitoring.

OCC (INPUT)

In the **ADVANCED SETUP** Menu

MA LO SET (45°F)

FREEZE POS (CLOSE)

STG3 DLY (2HRS)

SD DMPR POS (CLOSED)

In the **SETPOINTS** Menu

See Damper Minimum Position section for details

ALARM MONITORING

The controller is equipped with a 24V output signal that can be configured for remote alarm monitoring.

In the "SYSTEM SETUP" menu change the "AUX1 OUT" setting to "SYS".

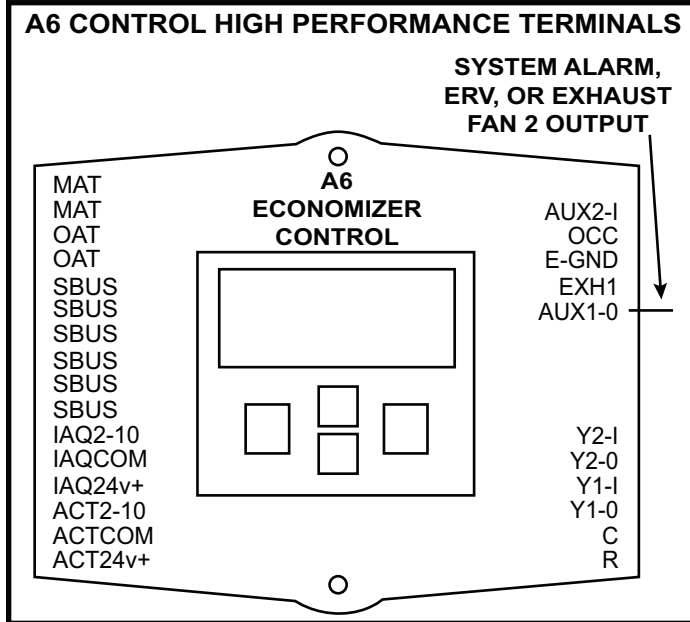

High Performance Economizer - Settings

FREE COOLING SETPOINT Single OA Sensible Sensing (Default)

The default free cooling setpoint or high limit setpoint is 63°F. This means that the outdoor air is suitable for free cooling at 62°F and below and not suitable at 64°F and above. This setpoint is adjustable.

For California Title 24 compliance, adjust the free cooling setpoint based on:

- The climate zone where the unit is installed. See Table 1.
- The setpoint requirement published by the California Energy Commission. See Section 140.4 - Prescriptive Requirements for Space Conditioning Systems of 2013 Building Energy Efficiency Standards.

Note - Values in the referenced standard will supersede values listing shown.

FREE COOLING SETPOINT - SINGLE SENSIBLE

Climate Zone	Setpoint
1, 3, 5, 11-16	75°F
2, 4, 10	73°F
6, 8, 9	71°F
7	69°F

To adjust the setpoint, navigate to the "SETPOINTS" menu and change the "DRYBLB SET" parameter accordingly.

Single OA Enthalpy Sensing (Optional) -

The controller uses enthalpy boundary "curves" for economizing when used with an enthalpy sensor. Refer to the Honeywell installation instruction for details.

Differential Sensing (Optional) -

Two sensors can be used to compare outdoor air to return air. When outdoor air is cooler than return air, outdoor air is suitable for free cooling. When return air is cooler than outdoor air, the damper will modulate to the minimum position.

DAMPER MINIMUM POSITION

Note - 24 volts must be provided at unit thermostat connection leads R and OC to enable economizer operation (allowing minimum fresh air). Typically a separately ordered thermostat or energy management system with and occupied/unoccupied output is connected between leads R and OC. The thermostat will provide 24 volts to the A6 economizer control during the occupied time period to enable economizer minimum position. If a device is not used to enable the economizer, install a jumper wire between leads R and OC to maintain minimum position continuously.

Make wire connection to leads R and OC as shown in literature provided with thermostat or energy management system.

- 1- Set thermostat to occupied mode if the feature is available. Make sure jumper is in place between leads R and OC if using a thermostat which does not have the feature.
- 2- Turn on the blower using the thermostat or a jumper between leads R and G.
- 3- Navigate to the "SETPOINTS" menu and select "MIN POS". Adjust value (2-10VDC) to approximate desired fresh air percentage.

- 3.0 VDC - 12% Open Damper
- 3.5 VDC - 18% Open Damper
- 4.0 VDC - 25% Open Damper
- 4.5 VDC - 31% Open Damper
- 5.0 VDC - 37% Open Damper
- 5.5 VDC - 43% Open Damper
- 6.0 VDC - 50% Open Damper

Note - Damper minimum position can be set lower than traditional minimum air requirements when an IAQ sensor is specified.

- 4- Measure outdoor air temperature. Mark the point on the bottom line of chart 1 and label the point "A" (40°F, 4°C shown).
- 5- Measure return air temperature. Mark that point on the top line of chart 1 and label the point "B" (74°F, 23°C shown).
- 6- Measure mixed air (outdoor and return air) temperature. Mark that point on the top line of chart 1 and label point "C" (70°F, 21°C shown).
- 7- Draw a straight line between points A and B.
- 8- Draw a vertical line through point C.
- 9- Draw a horizontal line where the two lines meet. Read the percent of fresh air intake on the side.
- 10- Repeat steps 3 through 8 until calculation reads desired fresh air percentage.

If fresh air percentage is less than desired, use the A6 keypad to adjust "MIN POS" values higher (further open). If fresh air percentage is more than desired, adjust "MIN POS" values lower (less open). Repeat steps 3 through 8 until calculation reads desired fresh air percentage.

DEMAND CONTROL VENTILATION (DCV)

When a 2- 10VDC CO2 sensor is wired to the controller (leads provided), the DCV SET, VENTMIN, and VENTMAX parameter will appear under "SETPOINTS" menu. Navigate to the "SETPOINTS" menu to adjust setpoints as desired. Refer to the Honeywell manual provided for more details.

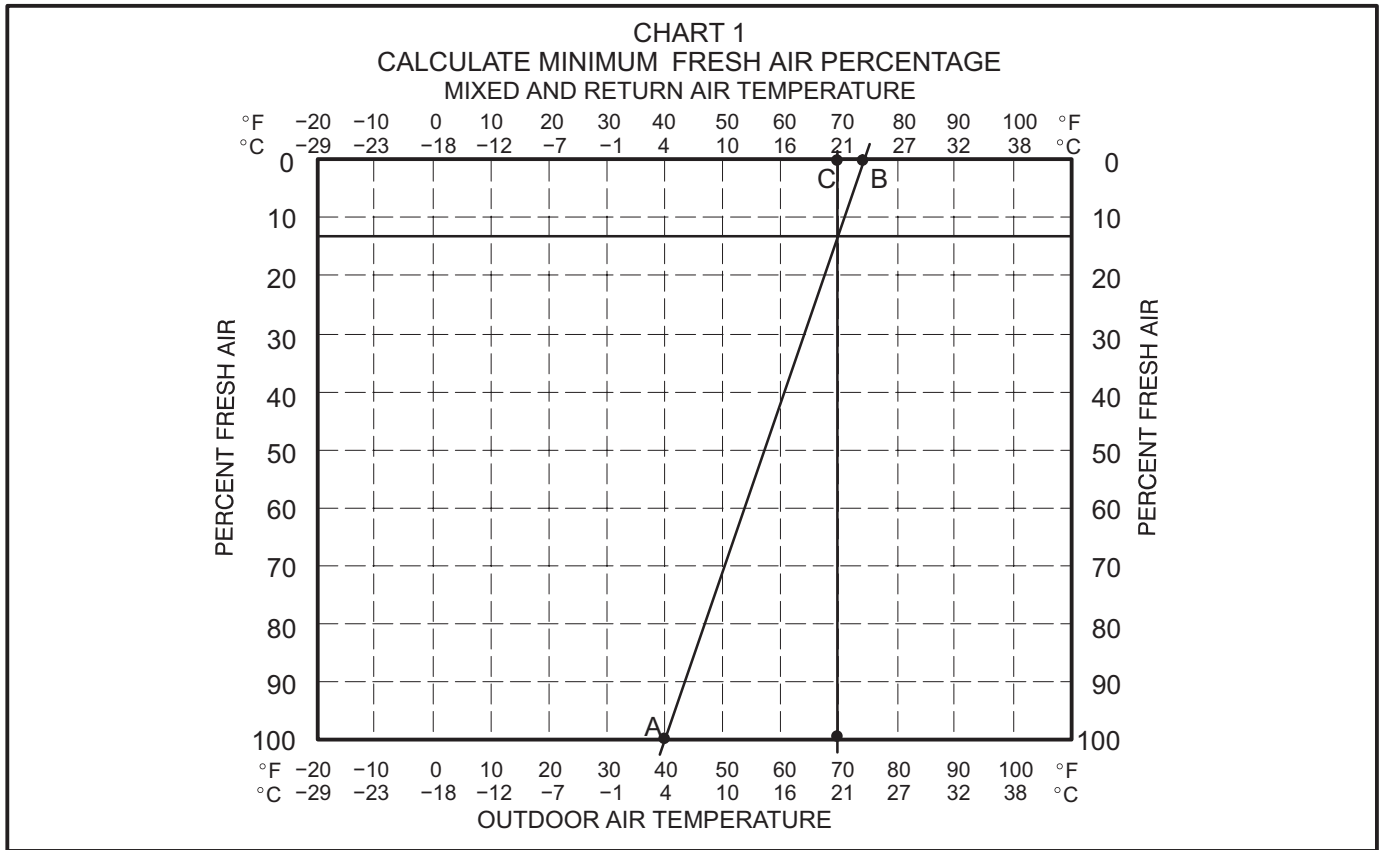

High Performance Economizer - Sequence of Operation

When the outdoor air is suitable and a thermostat demand calls for 1st. stage cooling (Y1), the economizer will modulate the dampers between the minimum and fully open positions to maintain a 55°F (12.8°C) mixed air temperature. When there is an increased thermostat demand for second stage cooling (Y2), the economizer damper opens 100% and the economizer controller (A6) will bring on the compressor. At that point, K8 relay will switch from the R1 mixed air sensor to R51 resistor allowing the economizer damper to stay open 100%. The damper will stay open 100% with the compressor running simultaneously until Y2 demand is met.

NOTE - Because of the sensor location, the mixed air temperature displayed on the economizer controller (A6) is only true when no mechanical cooling or heating is initiated. During mechanical cooling (compressor running), the MA temperature displayed will be the temperature equivalent of the fixed resistor and not the actual MA temperature.

TROUBLESHOOTING, ALARMS AND CHECKOUT TESTS

Refer to the Honeywell manual provided for details.

ECONOMIZER OPERATION - NO DCV (CO₂ SENSOR)

DCV	OA Good to Economizer?	Y1-I	Y2-I	Y1-O	Y2-O	Occupied	Unoccupied
None	No	Off	Off	0-v/Off	0-v/Off	MIN POS	Closed
		On	Off	24-v/On	0-v/Off	MIN POS	Closed
		On	On	24-v/On	24-v/On	MIN POS	Closed
None	Yes	Off	Off	0-v/Off	0-v/Off	MIN POS	Closed
		On	Off	0-v/Off	0-v/Off	MIN POS to Full-Open	Closed to Full-Open
		On	On	24-v/On	0-v/Off	Full-Open	Full-Open

ECONOMIZER OPERATION - WITH DCV (CO₂ SENSOR)

DCV	OA Good to Economizer?	Y1-I	Y2-I	Y1-O	Y2-O	Occupied	Unoccupied
Below set	No	Off	Off	0-v/Off	0-v/Off	VENTMIN	Closed
		On	Off	24-v/On	0-v/Off	VENTMIN	Closed
		On	On	24-v/On	24-v/On	VENTMIN	Closed
	Yes	Off	Off	0-v/Off	0-v/Off	VENTMIN	Closed
		On	Off	0-v/Off	0-v/Off	VENTMIN to Full-Open	Closed to Full-Open
		On	On	24-v/On	0-v/Off	Full-Open	Full-Open
Above set	No	Off	Off	0-v/Off	0-v/Off	VENTMIN to VENTMAX	Closed
		On	Off	24-v/On	0-v/Off	VENTMIN to VENTMAX	Closed
		On	On	24-v/On	24-v/On	VENTMIN to VENTMAX	Closed
	Yes	Off	Off	0-v/Off	0-v/Off	VENTMIN to VENTMAX	Closed
		On	Off	0-v/Off	0-v/Off	VENTMIN to Full-Open	Closed to Full-Open
		On	On	24-v/On	0-v/Off	Full-Open	Full-Open