



VENTILATORS

505,007M
8/2015
Supersedes 5/2013

LVCS VENTILATION CONTROL SYSTEM

INSTALLATION, OPERATION AND MAINTENANCE INSTRUCTIONS FOR HEALTHY CLIMATE® LENNOX VENTILATION CONTROL SYSTEM (LVCS) FOR USE WITH FURNACES AND AIR HANDLERS



THIS MANUAL MUST BE LEFT WITH THE HOMEOWNER FOR FUTURE REFERENCE

⚠ WARNING

Improper installation, adjustment, alteration, service or maintenance can cause personal injury, loss of life, or damage to property.

Installation and service must be performed by a licensed professional installer (or equivalent) or a service agency.

Shipping and Packing List

Check unit for shipping damage. Consult last carrier immediately if damage is found.

Qty.	Part Description
1	Digital ventilation controller (includes outdoor temperature sensor)
1	Motorized damper (spring-closed, power-open)
1	24VAC transformer

Application

Healthy Climate LVCS Ventilation Control System provides fresh air intake which can be used with any furnace or air handler. Fresh air is brought into the return air system, where it can be filtered. The controller allows fresh air intake using a motorized damper when outdoor conditions are appropriate. In very cold climates, balanced

ventilation is recommended. Ventilation control system can be used with an exhaust fan to provide balanced ventilation. Per ASHRAE 62.2-2010, very cold climates are those that have more than 9000 annual heating degree-days based on 65°F day.

Specification

Operating temperature range	20 - 160°F
Maximum current through VENT relay	2A
Input voltage	22 - 30 VAC
Minimum VA required	2.0 VA
Ventilation time/hour	0-60 minutes

Operation Principles

Working in conjunction with a normally closed motorized damper, the digital digital ventilation controller makes decisions regarding when – and how long – to ventilate. It does this through continuous monitoring of indoor relative humidity, outdoor temperature, and user-adjusted timer settings. Ventilation time may be satisfied by a heating, cooling, or fan call initiated by the thermostat, or from a fan call initiated by the ventilation controller itself.

Indoor relative humidity is monitored to help prevent high humidity conditions inside your home.

If the indoor RH is above 55% and the outdoor temperature is above 50°F the damper will not open due to the potential of introducing excess humidity into the conditioned space unless mode A (time-based ventilating regardless of temperature or humidity) is selected on the controller.

If the outdoor air temperature is

- Below 0°F or above 100°F in modes B, and C
- Below 0°F or above 90°F in mode D.

The normally closed motorized damper to the outside will not open. This function can be disabled by selecting mode A on the 4-way mode selector (see figure 8) were the outdoor air temperature and indoor humidity is not used as an input.

⚠ CAUTION

Improper wiring to the HVAC equipment could cause damage to the digital digital ventilation controller and/or the HVAC equipment.



⚠ WARNING



Electric Shock Hazard. Can cause injury or death. Unit must be grounded in accordance with national and local codes.

Line voltage is present at all components when unit is not in operation on units with single-pole contactors. Disconnect all remote electric power supplies before opening access panel. Unit may have multiple power supplies.

Installation

LVCS requires installation of a motorized damper, fresh air intake (such as wall-mounted hood), fresh air intake duct, digital ventilation controller, and 24VAC transformer.

Fresh air intake duct and damper should be installed between the outdoor wall and the return side of the HVAC equipment. The digital ventilation controller should be mounted in the return/mixing plenum and wired to the thermostat and the HVAC equipment.

INSTALLATION OF FRESH AIR INTAKE

NOTE - Fresh air intake should be located in accordance with local codes. Refer to installation guidelines as follows:

- At least 6 feet* away from dryer vents and furnace exhaust (high efficiency furnaces)
- A minimum of at least 6 feet* from sources of contaminated air (including driveways, oil fill pipes, gas meters, garbage containers or swimming pools)
- At least 18 inches* above the ground, or the depth of expected snow accumulation, whichever is higher
- At least 3 feet* from the inside/outside corner of the building
- Do not locate in any indoor space
- Provide 1/4" mesh screen or similar in the fresh air intake.

* **Local code may require greater distances.**

Refer to figures 1 and 2 for typical attic and basement installations.

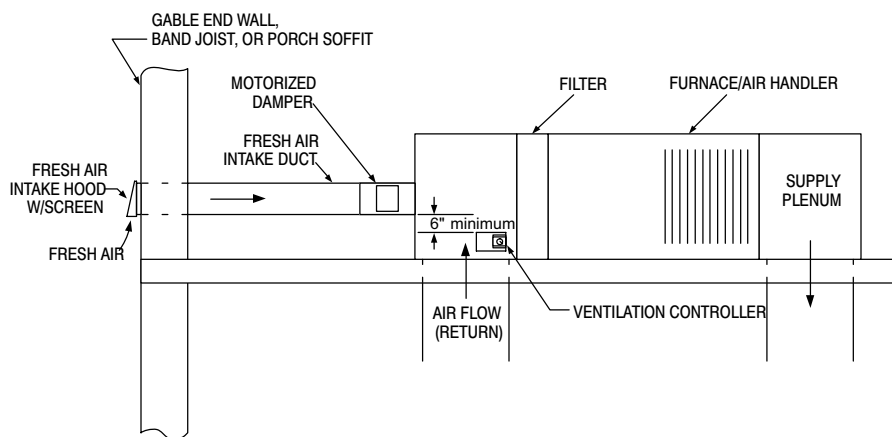

Figure 1. Typical Fresh Air Intake for Attic Installation

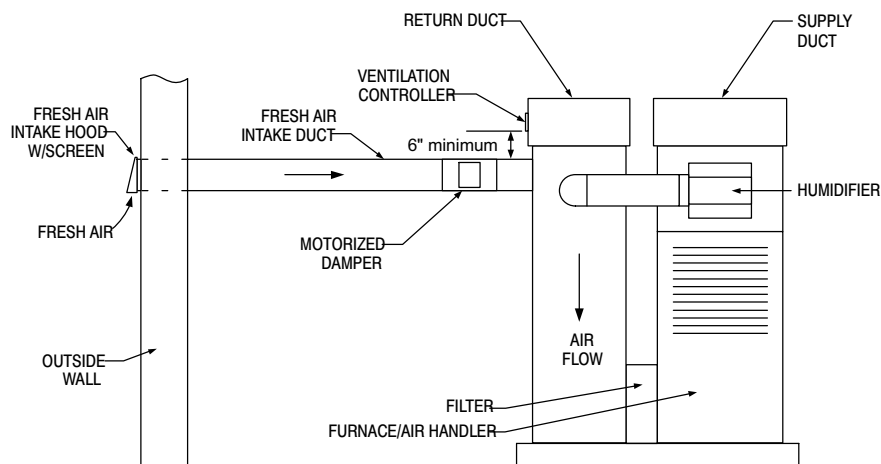

Figure 2. Typical Fresh Air Intake for Basement Installation

INSTALLATION OF DAMPER AND FRESH AIR INTAKE DUCT

NOTE - Support all ducts in accordance with local code or SMACNA standards.

⚠ CAUTION

Damper should be installed in fresh air duct only, and should be installed as close to the return duct as possible.

⚠ CAUTION

Do not force damper blades by hand, as damage may occur.

1. The motorized damper must be installed on a rigid return air duct or plenum. If flexible duct has been used rather than rigid duct for the return air, a field-provided return air mixing box must be installed. Position damper so that crimped end is downstream and attach damper to a return air duct, plenum, or mixing box.
2. Install 6 inches fresh air intake duct between the fresh air intake and damper. If metal fresh air duct is used, secure duct using 1/2 inch sheet metal screws (not included) and duct tape. If flexible fresh air duct is used, use proper strapping material to attach the duct to damper. Fresh air intake duct run should be as short as possible
3. The fresh air intake duct and damper must be fully insulated and all seams must be sealed to prevent condensation from forming. Refer to figure 3.

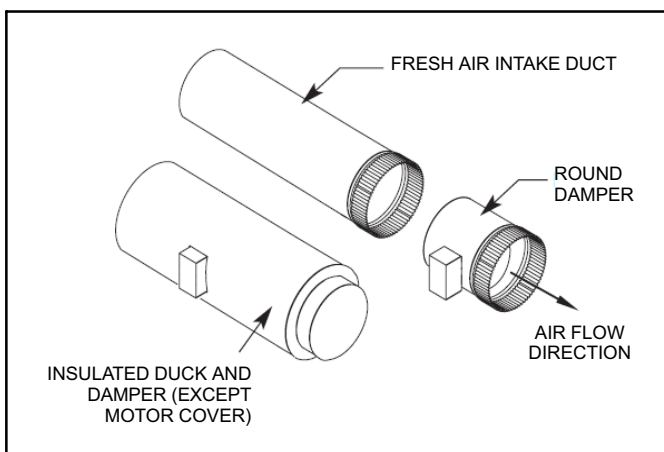

Figure 3. Damper and Fresh Air Duct Installation

INSTALLATION OF DIGITAL VENTILATION CONTROLLER

⚠ CAUTION

1. Do not mount the digital ventilation controller on the supply plenum duct. The unit will not withstand the supply temperatures.
2. When installing the digital ventilation controller on down-flow furnaces, ensure blower continues to run after a heat call is satisfied to eliminate high temperatures from damaging the digital ventilation controller.
3. Do not mount the digital ventilation controller downstream of a fresh air intake, humidifier or bypass outlet. False humidity conditions will cause the digital ventilation controller to operate incorrectly
4. UVC light may damage ventilation control system components. Do not install ventilation control system components where they may be exposed to UVC light.

The digital ventilation controller must be mounted in the return duct. For proper operation, the digital ventilation controller must be at least 6 inches upstream from the following:

- Fresh air intake duct connection
- Humidifier
- Humidifier bypass duct connection



Figure 4. digital ventilation controller

In installations where it is difficult to mount the digital ventilation controller 6 inches upstream from the fresh air intake duct (when using a mixing box with flex duct returns for example), then mount the digital ventilation controller as close to the main return duct as possible.

Do not install the digital ventilation controller on the bottom side of duct. Also, do not install the digital ventilation controller within 6 feet of direct UVC light exposure or within 3 feet of indirect UVC light exposure.

NOTE - Make sure the digital ventilation controller sensor gasket is sealed tightly around the drilled hole. Do not install the digital ventilation controller without the gasket.

1. Remove the knob.
2. Remove the cover by pulling at the bottom and swingout and up.
3. After the location of the digital ventilation controller is selected, drill a 3/4 inch hole for the RH sensor (the RH sensor extends from the back of the controller).

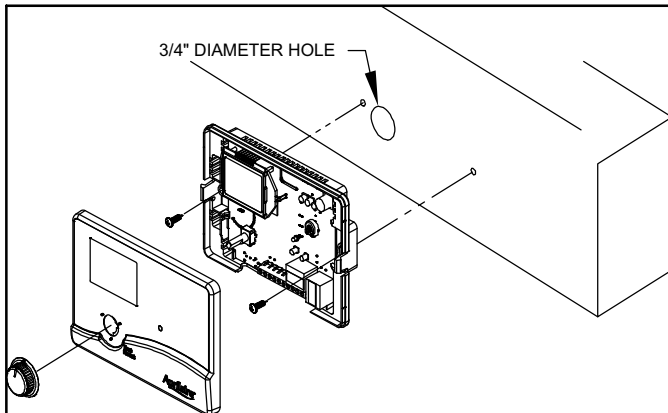

Figure 5. Mounting Digital Ventilation Controller (Metal Duct)

4. Before removing the adhesive backing, use the controller to mark the mounting holes and place anchors if applicable.
5. Clean the mounting surface of the duct, remove the adhesive backing from the gasket on the digital ventilation controller, and secure the digital ventilation controller to the duct making sure to align mounting holes and the RH sensor with the drilled hole.
 - **Mounting to Metal Duct:** use field-provided sheet metal screws to secure controller to duct.
 - **Mounting to Duct Board:** Use field-provided screws and anchors to secure controller to duct.

NOTE - Digital Ventilation Controller Replacement - When replacing an X4153 with an Y5862, the duct opening left by the removed digital ventilation controller must be covered completely. Locate and install the new controller as instructed above.

Field Wiring

DIGITAL VENTILATION CONTROLLER

NOTE - 18-22 AWG thermostat wire should be used.

⚠ CAUTION

Improper wiring to the HVAC equipment could cause damage to the digital digital ventilation controller and/or the HVAC equipment.

- Route wire from the **R**, **C** and **W** terminals on the digital ventilation controller to the corresponding terminals on the furnace / air handler/heat pump control. Do not remove any existing **R**, **C**, and **W** leads already connected. See figure 6 for the terminal locations.

*NOTE - Due to the digital ventilation controller being wired to **W** and **G**, ventilation would initiate with a call just from the heat pump. In the case where the digital ventilation controller is setup with an outdoor temperature sensor and the temperature is below 20°F (mode B), ventilation would only be allowed when there is an electric heat call.*

- Disconnect the thermostat wire from the HVAC terminal **G** and connect it to the digital ventilation control **G** terminal.
- Wire **Gf** on the digital ventilation control to the HVAC terminal **G**. The only wire connected to HVAC **G** will be from the ventilation control **Gf** terminal.
- Wire the 24VAC transformer (provided with the ventilation control only). The transformer should be continuously energized, do not wire into the HVAC blower circuit. The transformer, damper and the digital ventilation controller **VENT** terminals will be wired in series.

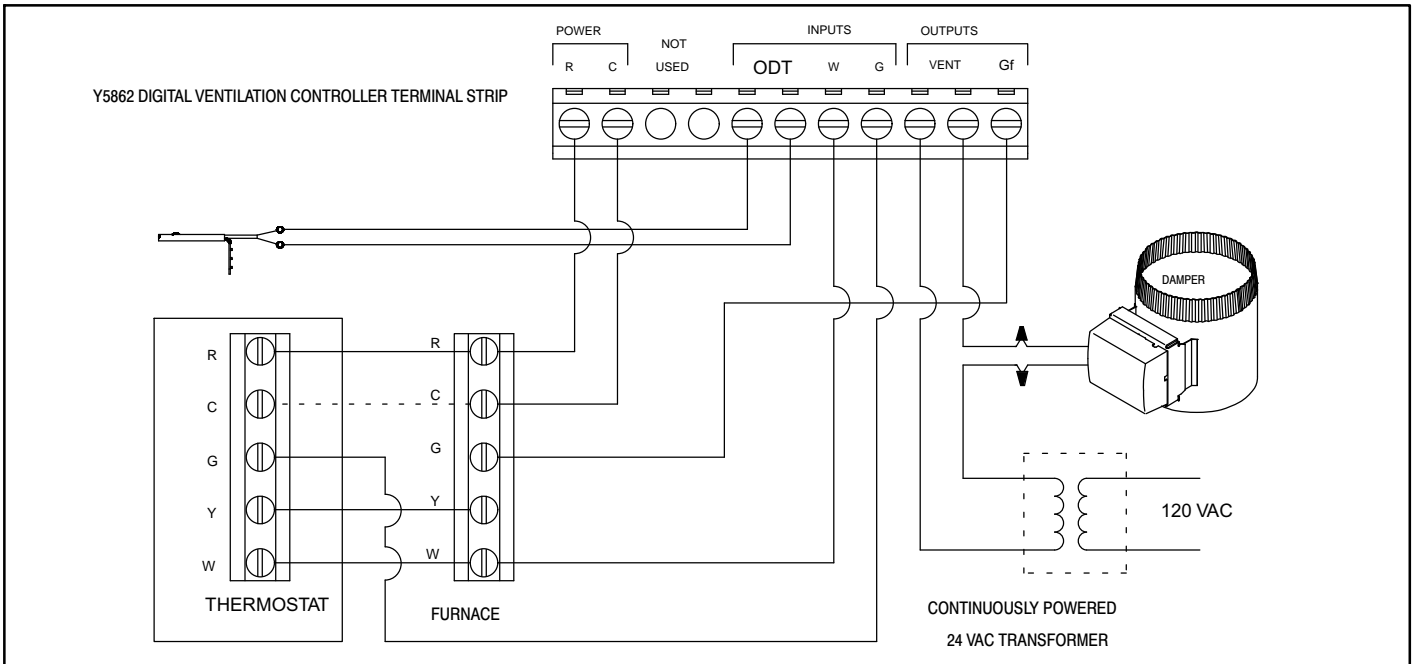

Figure 6. Wiring the Digital Ventilation Controller (Conventional 24VAC Thermostat Used)

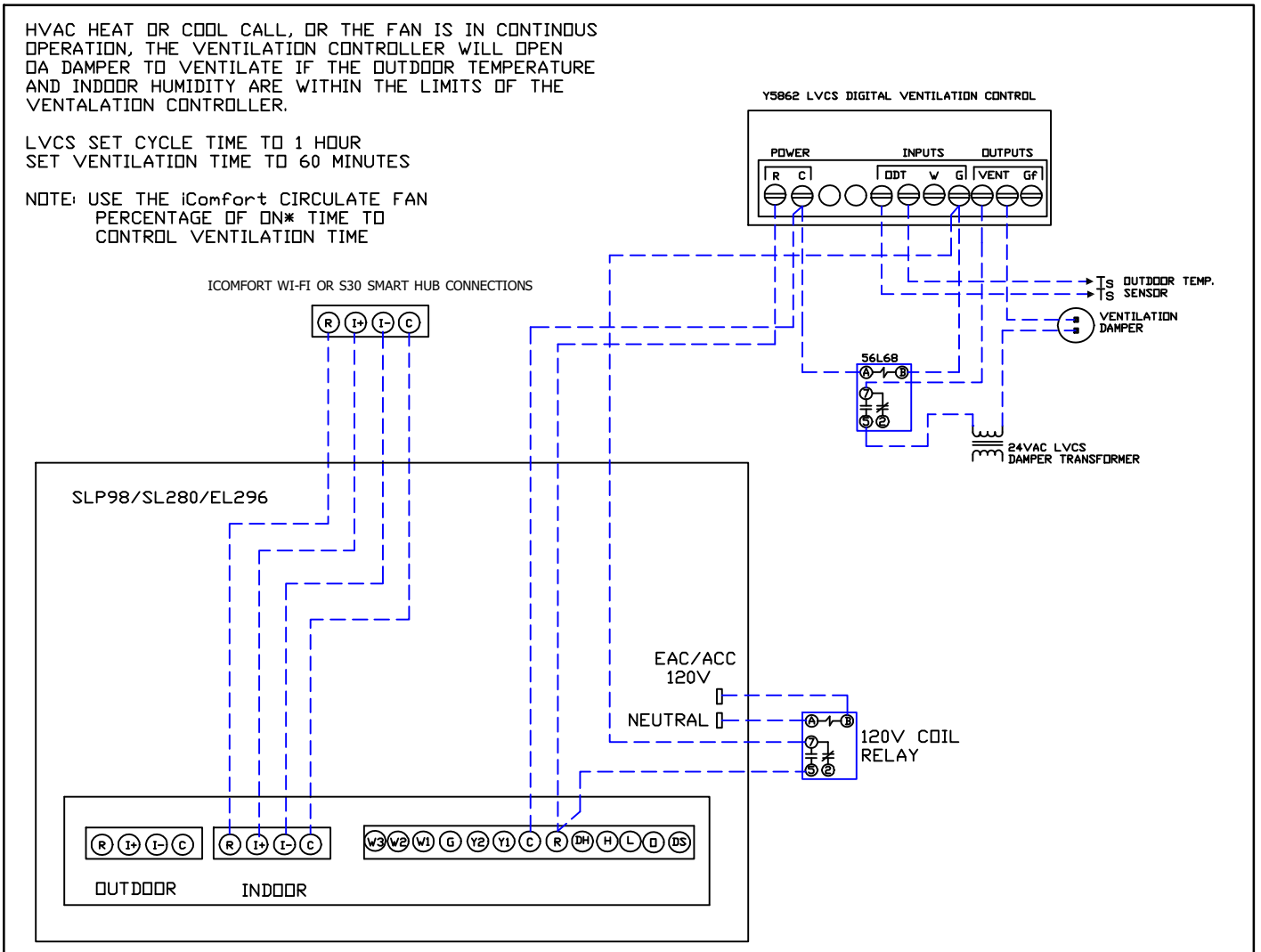

Figure 7. Wiring the Digital Ventilation Controller (iComfort Series Thermostat)

MOTORIZED DAMPER AND 24VAC TRANSFORMER

The normally closed damper should be wired in series with a continuously energized 24VAC transformer (provided) and connected to the terminals labeled **VENT** of the digital ventilation controller. See figure 6.

The 24VAC transformer will require 110VAC power supply and should be installed according to the local codes. Wire 24VAC transformer to power source other than furnace fan motor circuit. The transformer can be powered off the 120VAC line at the junction box before it enters the furnace. See furnace manufacturer's recommendations for wiring. 24VAC transformer is rated for use with one fresh air damper only and no additional components.

OUTDOOR TEMPERATURE SENSOR

The temperature sensor should be installed in the fresh air intake hood (not provided) or in the fresh air intake duct.

NOTE - The outdoor temperature sensor should be within 3 feet of the outside wall when mounted inside the fresh air intake duct.



- Use standard 18-22 AWG thermostat wire to field wire outdoor temperature sensor to the digital ventilation controller.

- The outdoor temperature sensor is not affected by field wire length up to 300 feet between the sensor and controller. Do not route the wire alongside wires carrying high voltage (120VAC or greater) as interference may occur.
- Strip wire 1/4 inch, and insert the field wires from the sensor into the terminals labeled **ODT** on the digital ventilation controller. See Figure 6 for terminal locations.
- Do not mount in direct sunlight or below the expected snow line on exterior wall.

Mode Selection

This digital ventilation controller is equipped with rotary DIP switch (see figure 8).

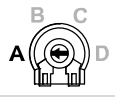
- The **A** mode allows the controller to ventilate based on time only.
- The **B**, **C** and **D** modes allow the digital ventilation controller to ventilate based upon time, outdoor temperature and indoor humidity.

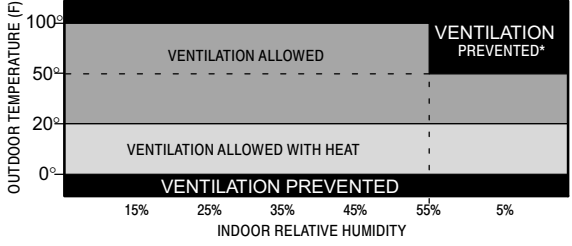
Position	Description	Chart
A (Time Only) 	Timer controlled ventilation (no temperature or humidity limits).	This setting can be calculated with ASHRAE 62-2-2010 standards. (Temperature and humidity sensors are ignored)
B (Default) 	Timer controlled ventilation with humidity and temperature limits	

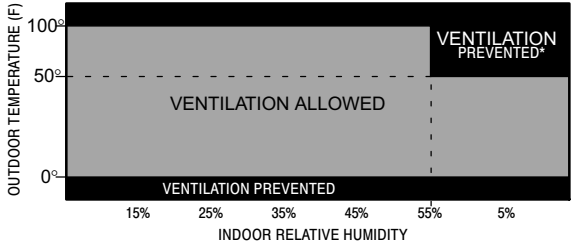
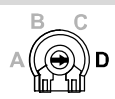
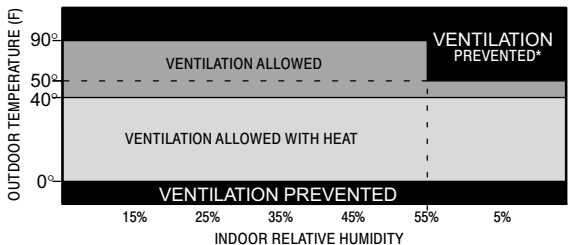
Position	Description	Chart
C (Cold Climate) 	Timer controlled ventilation with humidity and temperature limits	
D (Warm Climate) 	Timer controlled ventilation with humidity and temperature limits	

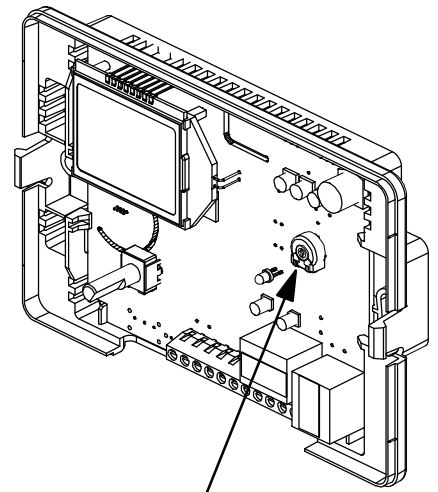

ROTARY DIP SWITCH

*If the indoor RH is above 55% and the outdoor temperature is above 50°F the damper will not open because of the potential of introducing excess humidity into the conditioned space.

Figure 8. Operating Modes

Determining Ventilation Requirements

Calculate ventilation time requirements and select ventilation time settings.

1. Determine the minimum ventilation requirements. This is calculated using ASHRAE 62.2.-2010.

Airflow in CFM = [house area in square feet x 0.01] + [number of bedrooms + 1 x 7.5] (Use the number of bedrooms plus 1 or the number of occupants, whichever is larger.

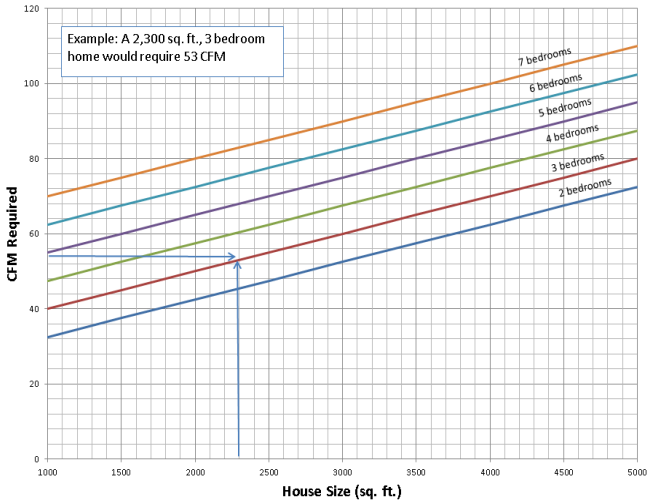

Figure 9

- A. Find square footage of house on horizontal axis. Draw a vertical line up from the bottom to the point that intersects the line for the number of bedrooms in the house.

NOTE - Additional ventilation may be required for pets, hobbies, fireplaces and attached garage, etc.

- B. From the point where the house size and bedroom lines intersect, draw a horizontal line to the left (vertical) axis to determine how much ventilation air (CFM) is required.

Indicate the required CFM _____

2. Determine how much ventilation air the system will deliver.

Table 1. Ventilation Air the System will Deliver - (CFM)

See Note	Negative Static Pressure ("w.c.) as Measured for Return Duct or Plenum											
	0.05		0.1		0.15		0.2		0.25		0.3	
	Flex	Pipe	Flex	Pipe	Flex	Pipe	Flex	Pipe	Flex	Pipe	Flex	Pipe
10 ft.	60	65	85	90	105	110	120	125	135	140	150	160
20 ft.	55	60	80	85	100	105	115	120	130	135	140	150
30 ft.	50	55	75	80	95	100	110	115	125	130	130	140

Note: Length of 6 inch diameter fresh air intake duct.

- A. Measure the negative static pressure of the return system and consult table 1 for approximate inlet airflow. These values are not absolute. An airflow measuring device will give the digital ventilation controller's airflow exactly.

- For table 1, the flex duct is laid loose with two wide 90° bends, and the damper is full open.
- For the rigid pipe the values are based on two 90° elbows, and the damper is open.
- For both cases the air intake is through a metal vent hood with a bird screen.

- B. Adjust airflow up or down for variations, including elbows or bends, or if the length of duct you are using is not listed, etc.

- C. Measure the delivered airflow or determine from table 1 and record _____.

3. Determining the digital ventilation controller knob setting.

- A. Using the value obtained in step 1, locate the CFM required on the left (vertical) axis and draw a horizontal line to the end of the chart.

- B. Using the value obtained in step 2, locate the CFM delivered on the horizontal axis and draw a vertical line up from the bottom to a point beyond the vertical CFM required line/

- C. The point where the two lines intersect indicates where the ventilation Time should be set. It may be necessary to estimate the precise setting if the intersection point falls between two lines.

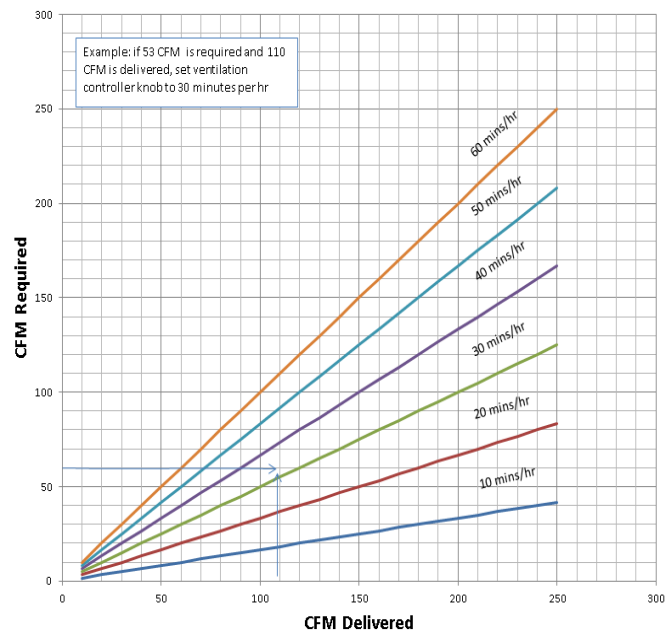

Figure 10

- D. If more outdoor air is required than the digital ventilation controller can deliver, increase delivered CFM by reducing bends in duct, increasing duct size, adding a second duct or adding a powered fan.

System Checkout

Turn the time setting knob to the TEST/RESET position. If the installation is correct the HVAC blower will turn on (independent of heat or cooling operations) and the damper will open for 1 minute unless the knob is turned off of TEST/RESET. If the system does not operate, then see the troubleshooting section.

Return the time setting knob to the calculated setting. **Do not leave in TEST/RESET, the digital ventilation controller will not operate.**

System Checkout

Repair Part	Lennox Catalog Number
Digital ventilation controller	Y5862
Motorized damper (spring-closed, power-open)	X4152
24VAC transformer	22N03
Outdoor temperature sensor	58N66

Troubleshooting

Table 2. Troubleshooting

Symptom	Troubleshooting Procedure
HVAC blower does not turn on in Test Mode.	<ol style="list-style-type: none"> 1. Make sure HVAC equipment has power. 2. Check the wiring for R, C, W, G and Gf at both the HVAC equipment and the digital ventilation controller. 3. Check voltage across the digital ventilation controller R & C and C & Gf terminals. Voltage should be in the 22 to 30VAC range.
Damper does not open in Test Mode	<ol style="list-style-type: none"> 1. Make sure HVAC equipment has power. 2. Check the wiring for R, C, W, G and Gf at both the HVAC equipment and the digital ventilation controller. 3. Check voltage across the digital ventilation controller R & C and C & Gf terminals. Voltage should be in the 22 to 30VAC range. 4. Check wiring diagram to make sure the damper is wired in series with the circuit board and transformer.
The damper does not open with the blower operating.	<ol style="list-style-type: none"> 1. The damper will not operate once the ventilation time interval has been met. For example, if the knob is turned to 5 minutes and 5 minutes has elapsed, the damper will close and it will stay closed until the next 1-hour interval. <p>FOR ALL MODES EXCEPT MODE A</p> <ol style="list-style-type: none"> 2. If the indoor RH is above 55% and the outdoor temperature is above 50°F the damper will not open because of the potential of introducing excess humidity into the conditioned space. 3. If the outdoor temperature is below 0°F or above 100°F the damper stays closed. 4. Verify that the outdoor temperature sensor is installed properly. 5. Turbulence in the return duct, plenum or mixing box can give false readings. Confirm proper location. 6. In Mode B, a heat call is required for ventilation under 20°F. 7. In Mode D, a heat call is required for ventilation under 40°F.
Blower turns on unexpectedly.	If ventilation time has not been met, the controller will activate the blower. This is normal operation.

Table 3. Error Codes

Error Code	Troubleshooting Procedure																														
E1 - RH Sensor	Rotate knob to the TEST/RESET position. After 5 seconds, the green indicator will blink, resetting the error. If E1 returns, replace the controller.																														
E2 - Controller Knob	Rotate knob to the TEST/RESET position. After 5 seconds, the green indicator will blink, resetting the error. If E2 returns, replace the controller.																														
E3 - Outdoor Temperature Sensor	<ol style="list-style-type: none"> 1. Make sure that the outdoor temperature sensor (ODT) is properly connected to the ODT terminals on the controller. 2. Measure the resistance of the ODT sensor by removing the wires from the terminals and measuring the resistance across the wires with an ohmmeter. Confirm the reading with the temperature in the table. If the resistance values does not match the temperature valve, replace the ODT sensor. 3. Reset error by rotating knob to TEST/RESET then back to the normal settings. <p><i>NOTE - ODT must be installed for modes B, C and D.</i></p> <table border="1" style="float: right; margin-left: 20px;"> <thead> <tr> <th>Outdoor Temperature (°f)</th> <th>Resistance (kΩ) ±10</th> </tr> </thead> <tbody> <tr><td>-30</td><td>231.8</td></tr> <tr><td>-20</td><td>163.4</td></tr> <tr><td>-10</td><td>117.3</td></tr> <tr><td>0</td><td>84.3</td></tr> <tr><td>10</td><td>62.3</td></tr> <tr><td>20</td><td>46.1</td></tr> <tr><td>30</td><td>34.4</td></tr> <tr><td>40</td><td>26.1</td></tr> <tr><td>50</td><td>19.9</td></tr> <tr><td>60</td><td>15.3</td></tr> <tr><td>70</td><td>11.9</td></tr> <tr><td>80</td><td>9.3</td></tr> <tr><td>90</td><td>7.3</td></tr> <tr><td>100</td><td>5.8</td></tr> </tbody> </table>	Outdoor Temperature (°f)	Resistance (kΩ) ±10	-30	231.8	-20	163.4	-10	117.3	0	84.3	10	62.3	20	46.1	30	34.4	40	26.1	50	19.9	60	15.3	70	11.9	80	9.3	90	7.3	100	5.8
Outdoor Temperature (°f)	Resistance (kΩ) ±10																														
-30	231.8																														
-20	163.4																														
-10	117.3																														
0	84.3																														
10	62.3																														
20	46.1																														
30	34.4																														
40	26.1																														
50	19.9																														
60	15.3																														
70	11.9																														
80	9.3																														
90	7.3																														
100	5.8																														