

UP-FLOW — CASSED AND UNCASSED

INSTALLATION INSTRUCTIONS

C33/CX34 Series Coils

EVAPORATOR COILS
 505,060M (065594210)
 9/2014
 Supersedes 9/2012

TP Technical
 Publications
 Litho U.S.A.

Table of Contents

Shipping and Packing List	1
General	1
Model Number Identification	2
Dimensions	2
C33 Optional Coil Adaptor / Seal Applications	11
Releasing Air Charge	12
Unit Installation	12
Refrigerant Line Set	13
Replacement Parts	14
Connections	14
Refrigerant Metering Device	15
Leaking Testing, Evacuating and Charging	17
Sealing Ducts	17
Condensate Drain Connection	17
Blower Speed Connection	18
Maintenance	19

THIS MANUAL MUST BE LEFT WITH THE HOMEOWNER FOR FUTURE REFERENCE

General

These instructions are intended as a general guide and do not supersede local or national codes in any way. Authorities who have jurisdiction should be consulted before installation.

The C33 and CX34 upflow evaporator coils are designed to be used with air conditioner or heat pump units

- The C33 coil include a factory-installed HFC-410A fixed orifice (RFC) metering device and is available either cased or uncased.
- The CX34 coil includes a factory-installed HFC-410A check expansion valve (externally equalized) and is only available cased.

Refer to the Product Specification bulletin (EHB) for the proper use of these coils with specific furnaces, air handlers, and line sets.

⚠ WARNING

The State of California has determined that this product may contain or produce a chemical or chemicals, in very low doses, which may cause serious illness or death. It may also cause cancer, birth defects, or reproductive harm.

⚠ WARNING

Improper installation, adjustment, alteration, service or maintenance can cause personal injury, loss of life, or damage to property.

Installation and service must be performed by a licensed professional installer (or equivalent) or a service agency.

⚠ CAUTION

Physical contact with metal edges and corners while applying excessive force or rapid motion can result in personal injury. Be aware of, and use caution when working near these areas during installation or while servicing this equipment.

⚠ IMPORTANT

The Clean Air Act of 1990 bans the intentional venting of refrigerant (CFCs, HCFCs and HFCs) as of July 1, 1992. Approved methods of recovery, recycling or reclaiming must be followed. Fines and/or incarceration may be levied for non-compliance.

Shipping and Packing List

Check the components for shipping damage. If you find any damage, immediately contact the last carrier.

Package 1 of 1 contains the following:

C33

- 1 — Evaporator coil
- 1 — Patch plate with nameplate label (uncased coils only)
- 1 — Metering device label (uncased coils only)

OR

CX34

- 1 — Evaporator coil



Model Number Identification

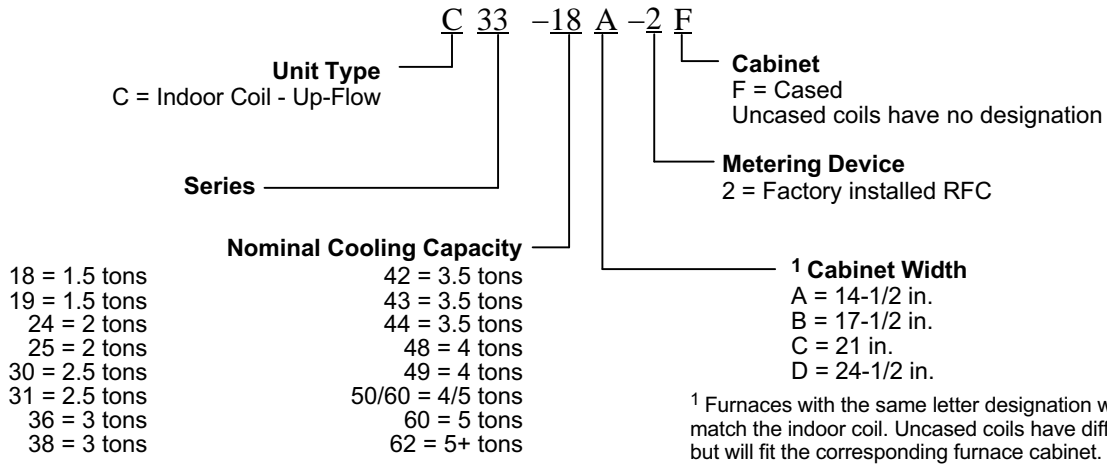

Dimensions - Inches (MM)

UNCASED COILS

C33-18A, -19A, -25, -31, -43, 48 and 50/60C Coils

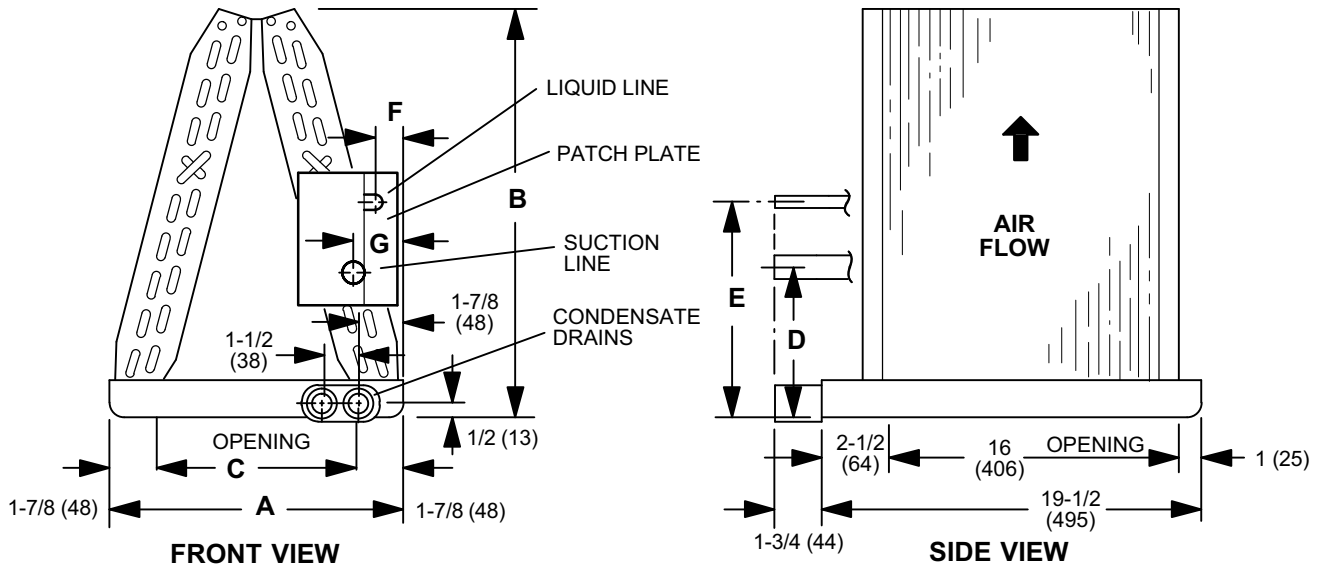

Model No.	A		B		C		D		E		F		G	
	in.	mm	in.	mm	in.	mm	in.	mm	in.	mm	in.	mm	in.	mm
C33-18A-2	13	330	9-3/4	248	10-1/4	260	6-7/8	175	9-7/8	251	7/8	22	2	51
C33-19A-2	13	330	14	356	10-1/4	260	10-1/8	257	13-1/8	333	2-1/4	57	3-1/8	79
C33-25A-2	13	330	16-1/4	413	10-1/4	260	12-1/8	308	15-1/8	384	2-1/4	57	3-1/8	79
C33-25B-2	15-1/2	394	15-7/8	403	11-3/4	298	12-1/8	308	15-1/8	321	2-1/4	57	3-1/8	79
C33-31A-2	13	330	21-1/4	540	10-1/4	260	11-5/8	295	14-5/8	371	3/4	19	1-5/8	41
C33-31B-2	15-1/2	394	20-1/4	514	11-3/4	298	11-5/8	295	14-5/8	371	2-1/4	57	2-7/8	73
C33-43B-2	15-1/2	394	26-1/4	667	11-3/4	298	15-7/8	403	18-7/8	479	2-1/4	57	3-1/8	79
C33-43C-2	20	508	25-3/4	654	15-3/4	400	15-7/8	403	18-7/8	479	2-1/4	57	3-1/8	79
C33-48B-2	15-1/2	394	22-1/8	562	11-3/4	298	9-1/8	232	12-1/8	308	2	51	3-1/8	79
C33-48C-2	20	508	21-1/2	546	15-3/4	400	12-1/8	308	15-1/8	384	2	51	3-1/8	79
C33-50/60C-2	20	508	26-3/4	679	15-3/4	400	15-7/8	403	18-7/8	479	2	51	3-1/8	79

C33-24, -30, -36, -38, -42B and 44C Coils

(NOTE - See next page for C33-49C-2 and C33-62C-2 Coils)

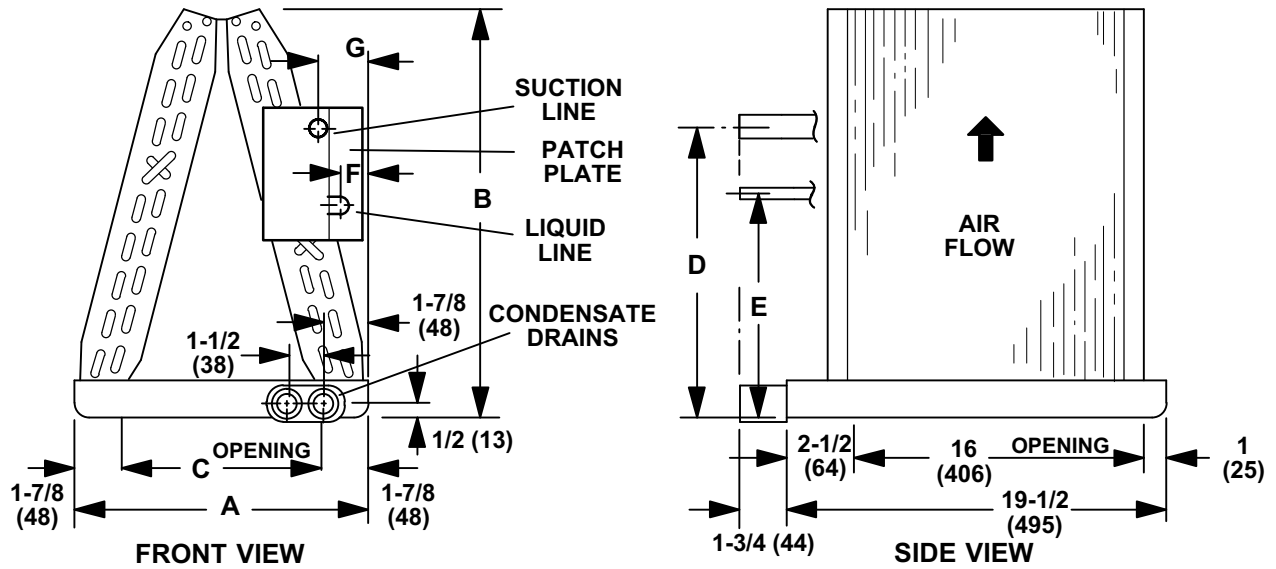

Model No.	A		B		C		D		E		F		G	
	in.	mm	in.	mm	in.	mm	in.	mm	in.	mm	in.	mm	in.	mm
C33-24A-2	13	330	14	356	10-1/4	260	10-3/8	264	7-3/8	187	2-1/4	57	3-1/8	79
C33-24B-2	15-1/2	394	13-7/8	352	11-3/4	298	10-1/2	267	7-1/2	191	2-1/4	57	3-1/8	79
C33-24C-2	20	508	13-7/8	352	15-3/4	400	10-1/2	267	7-1/2	191	2-1/4	57	3-1/8	79
C33-30A-2	13	330	18	457	10-1/4	260	14-1/2	368	11-1/2	292	2-1/4	57	3-1/8	79
C33-30B-2	15-1/2	394	17-3/4	451	11-3/4	298	14-1/2	368	11-1/2	292	2-1/4	57	3-1/8	79
C33-30C-2	20	508	17-3/4	451	15-3/4	400	14-1/2	368	11-1/2	292	2-1/4	51	3-1/8	79
C33-36A-2	13	330	22-1/8	562	10-1/4	260	18-1/2	470	15-5/8	397	2-1/4	57	3-1/8	79
C33-36B-2	15-1/2	394	21-7/8	556	11-3/4	298	17-7/8	454	14-7/8	378	2-1/4	57	3-1/8	79
C33-36C-2	20	508	21-1/4	540	15-3/4	400	18-7/8	479	15-7/8	403	2-1/4	57	3-1/8	79
C33-38A-2	13	330	22-1/4	565	10-1/4	260	17-1/2	445	14-5/8	371	2	51	3-1/8	79
C33-38B-2	15-1/2	394	22	559	11-3/4	298	17-5/8	448	14-3/4	375	1-3/4	44	2-7/8	73
C33-42B-2	15-1/2	394	21-7/8	556	11-3/4	298	17-7/8	454	14-7/8	378	2	51	3-1/8	79
C33-44C-2	20	508	21-1/2	546	15-3/4	400	18-3/4	476	15-3/4	400	3-3/4	95	4-7/8	124

C33-49C and C33-62C Coils

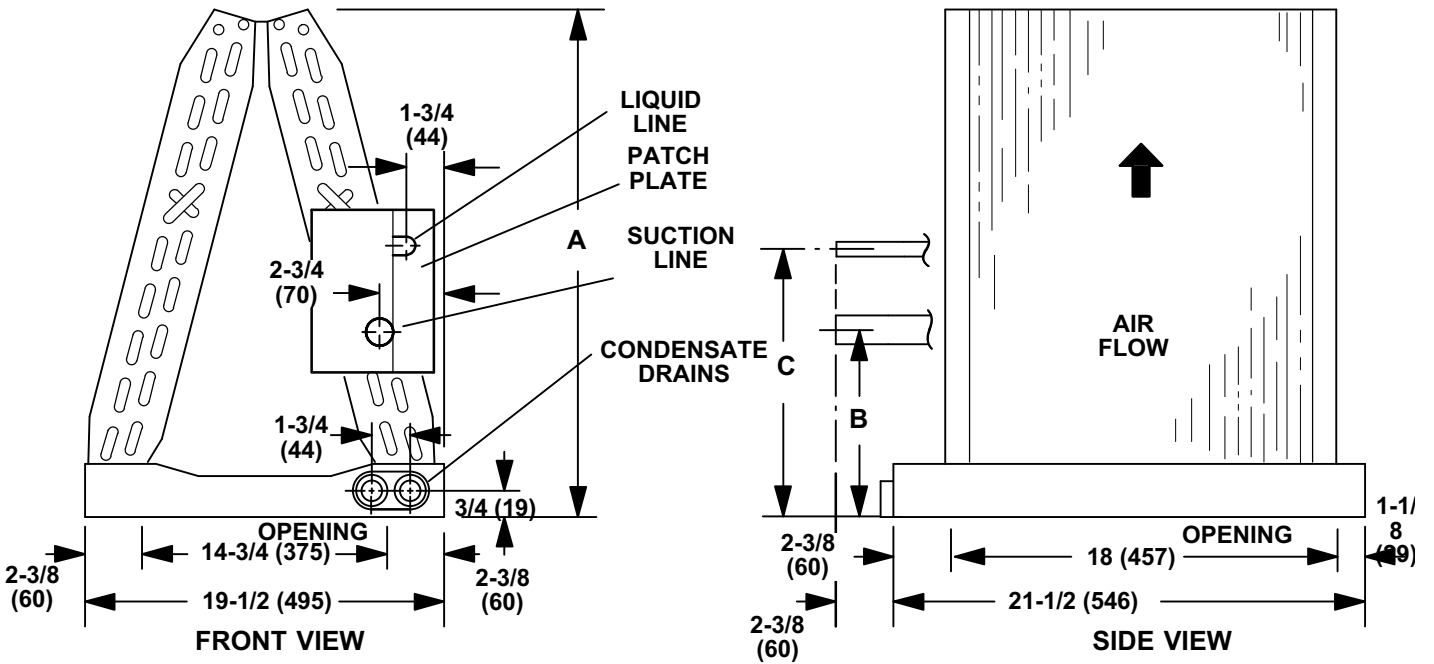

Model No.	A		B		C	
	in.	mm	in.	mm	in.	mm
C33-49C-2	28-1/2	724	15-1/8	384	18-1/8	460
C33-62C-2	30-5/8	778	18-1/8	460	21-1/8	537

C33-60D and C33-62D Coils

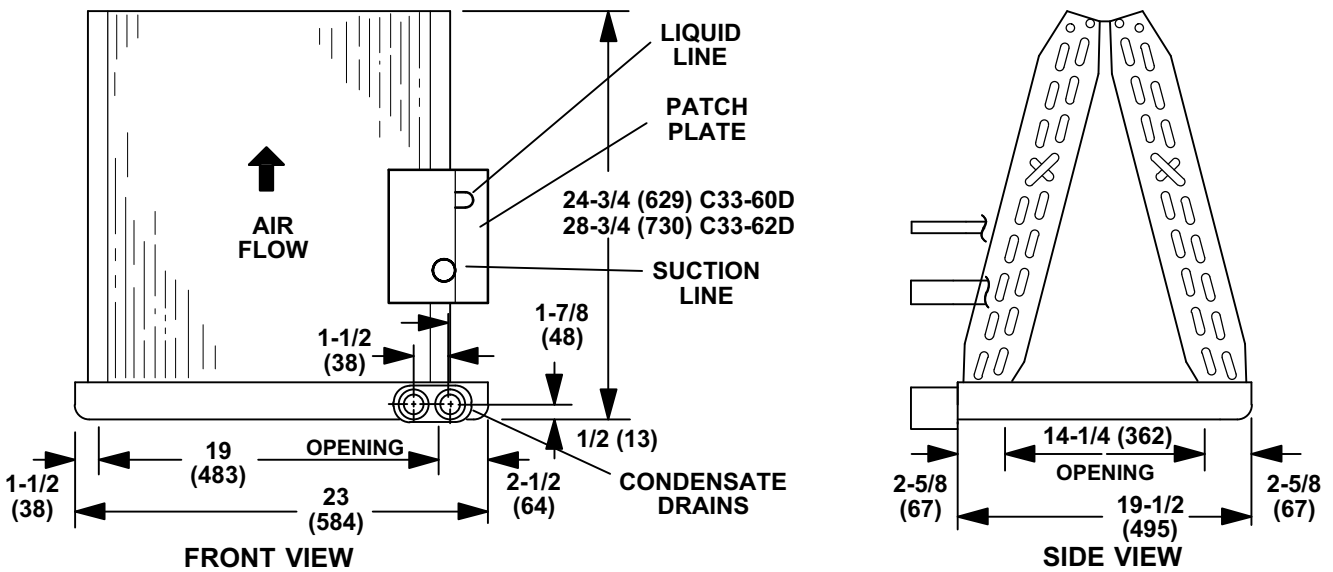

C33-24, -30, -36, -38, -42B and -44C Coils

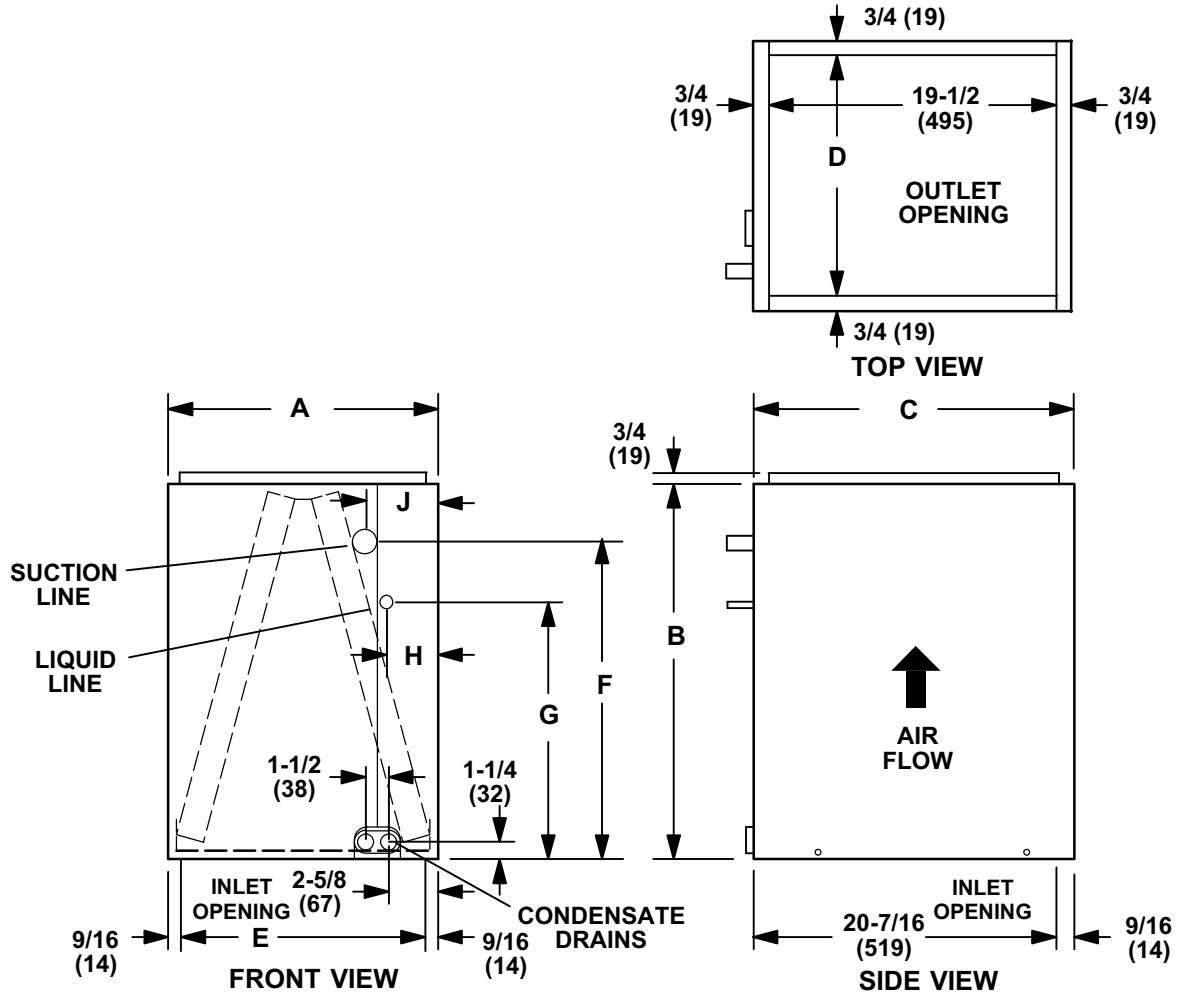

Model No.	A		B		C		D		E		F		G		H		J	
	in.	mm	in.	mm	in.	mm	in.	mm	in.	mm	in.	mm	in.	mm	in.	mm	in.	mm
C33-24A-2F	14-1/2	368	16-1/2	419	21	533	13	330	13-3/8	340	11-1/8	283	8-1/8	206	3	76	3-7/8	98
C33-24B-2F	17-1/2	445	16-1/2	419	21	533	16	406	16-3/8	416	11-1/4	286	8-1/4	210	3	76	4-1/8	105
C33-24C-2F	21	533	16-1/2	419	21	533	19-1/2	495	19-7/8	505	11-1/4	286	8-1/4	210	3	76	4-1/8	105
C33-30A-2F	14-1/2	368	20-1/2	521	21	533	13	330	13-3/8	340	15-1/4	387	12-1/4	311	2-3/4	70	3-7/8	98
C33-30B-2F	17-1/2	445	20-1/2	521	21	533	16	406	16-3/8	416	15-1/4	387	12-1/4	311	3	76	4-1/8	105
C33-30C-2F	21	533	20-1/2	521	21	533	19-1/2	495	19-7/8	505	15-1/4	387	12-1/4	311	3	76	4-1/8	105
C33-36A-2F	14-1/2	368	24-1/2	622	21	533	13	330	13-3/8	340	19-1/4	489	16-3/8	416	2-3/4	70	3-7/8	98
C33-36B-2F	17-1/2	445	24-1/2	622	21	533	16	406	16-3/8	416	18-5/8	473	15-5/8	397	3	76	4-1/8	105
C33-36C-2F	21	533	24-1/2	622	21	533	19-1/2	495	19-7/8	505	19-5/8	498	16-5/8	422	4-3/4	121	3-5/8	92
C33-38A-2F	14-1/2	368	24-1/2	622	21	533	13	330	13-3/8	340	18-1/4	464	15-3/8	391	2-3/4	70	3-7/8	98
C33-38B-2F	17-1/2	445	24-1/2	622	21	533	16	406	16-3/8	416	18-3/8	467	15-1/2	394	2-3/4	70	3-7/8	98
C33-42B-2F	17-1/2	445	24-1/2	622	21	533	16	406	16-3/8	416	18-5/8	467	15-5/8	397	3	76	4-1/8	105
C33-44C-2F	21	533	24-1/2	622	21	533	19-1/2	495	19-7/8	505	19-1/2	495	16-1/2	419	4-1/4	108	5-3/8	137

C33-18A, 19A, -25, -31, -43, -48, -50/60C, -60D and -62D Coils
 (NOTE - See next page for C33-49C-2F and C33-62C-2F Coils)

NOTE- C33-60D and C33-62D coils are positioned in cabinet with coil running left to right, all other coil sizes are positioned like drawing.

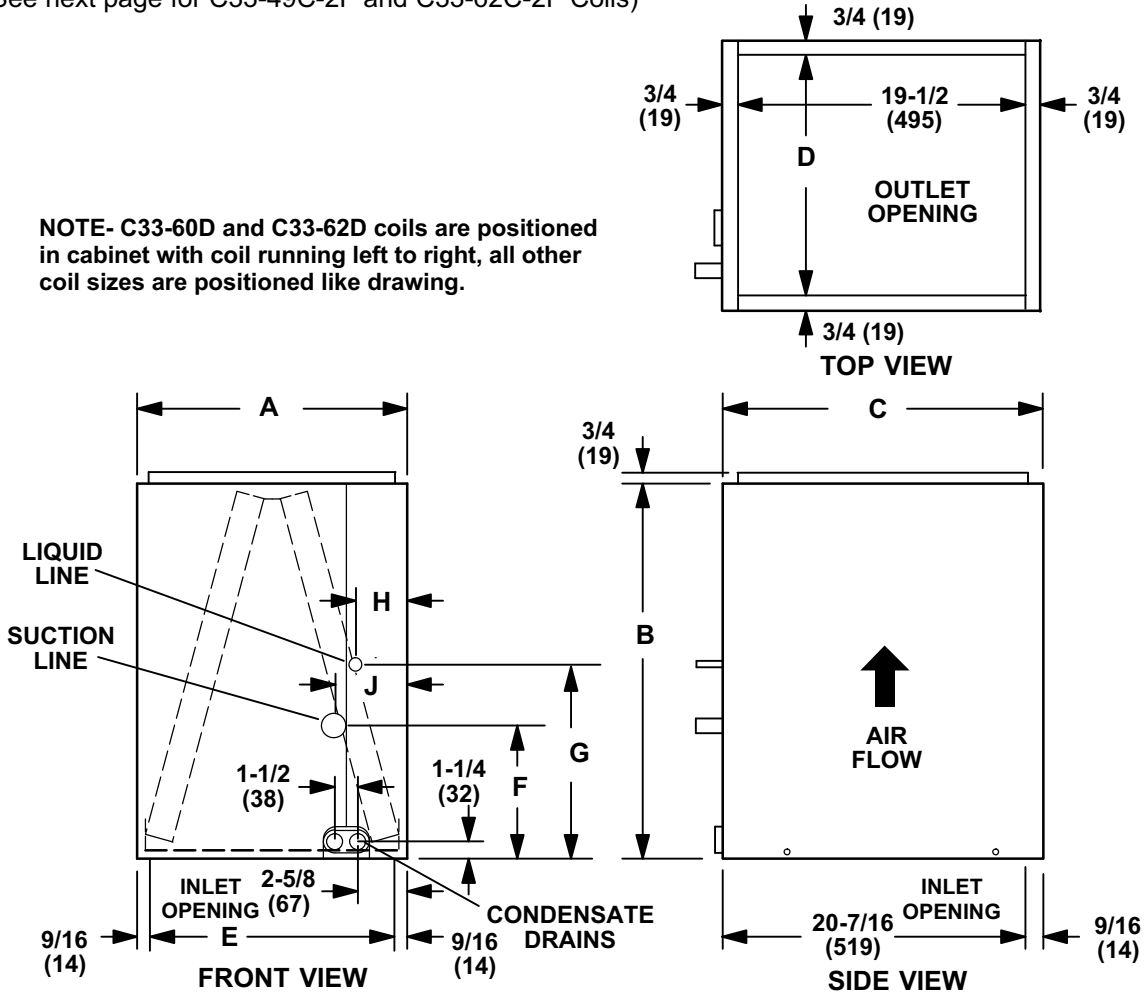

Model No.	A		B		C		D		E		F		G		H		J	
	in.	mm	in.	mm	in.	mm	in.	mm	in.	mm	in.	mm	in.	mm	in.	mm	in.	mm
C33-18A-2F	14-1/2	368	12-1/2	318	21	533	13	330	13-3/8	340	7-1/2	191	10-1/2	267	1-3/4	44	2-7/8	73
C33-19A-2F	14-1/2	368	16-1/2	419	21	533	13	330	13-3/8	340	10-7/8	276	13-7/8	353	3	76	3-7/8	98
C33-25A-2F	14-1/2	368	18-1/2	470	21	533	13	330	13-3/8	340	12-7/8	327	15-7/8	403	3	76	3-7/8	98
C33-25B-2F	17-1/2	445	18-1/2	470	21	533	16	406	16-3/8	416	12-7/8	327	15-7/8	403	3-1/4	83	4-1/8	105
C33-31A-2F	14-1/2	368	22-1/2	572	21	533	13	330	13-3/8	340	12-3/8	314	15-3/8	391	1-1/2	38	2-3/8	60
C33-31B-2F	17-1/2	445	22-1/2	572	21	533	16	406	16-3/8	416	12-3/8	314	15-3/8	391	3-1/4	83	4-1/8	105
C33-43B-2F	17-1/2	445	27-1/2	699	21	533	16	406	16-3/8	416	16-3/4	425	19-3/4	502	3-1/4	83	4-1/8	105
C33-43C-2F	21	533	27-1/2	699	21	533	19-1/2	495	19-7/8	505	16-3/4	425	19-3/4	502	2-3/4	70	3-5/8	92
C33-48B-2F	17-1/2	445	24-1/2	622	21	533	16	406	16-3/8	416	9-3/4	248	12-3/4	324	3	76	4-1/8	105
C33-48C-2F	21	533	24-1/2	622	21	533	19-1/2	495	19-7/8	505	12-3/4	324	15-3/4	400	2-1/2	64	3-5/8	92
C33-50/60C-2F	21	533	27-1/2	699	21	533	19-1/2	495	19-7/8	505	16-1/2	419	19-1/2	495	2-1/2	64	3-5/8	92
C33-60D-2F	24-1/2	622	25-1/2	648	21	533	23	584	23-3/8	594	11-7/8	302	14-7/8	518	1-5/8	41	2-3/4	70
C33-62D-2F	24-1/2	622	29-1/2	749	21	533	23	584	23-3/8	594	18-7/8	479	21-7/8	556	1-5/8	41	2-3/4	70

C33-49C-2F and C33-62C-2F

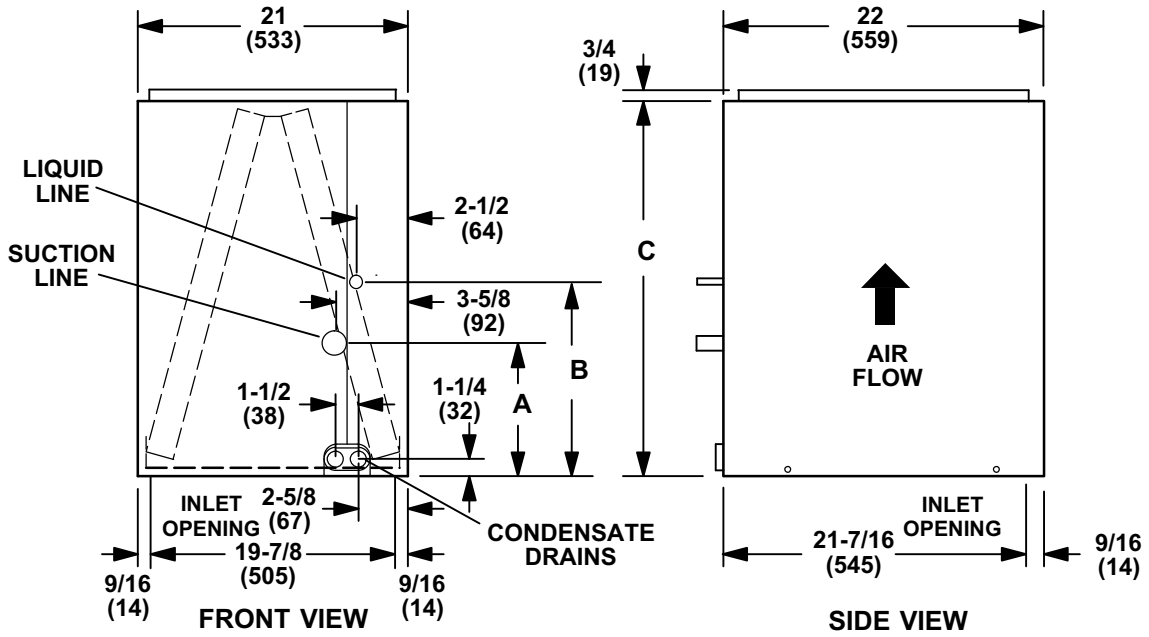
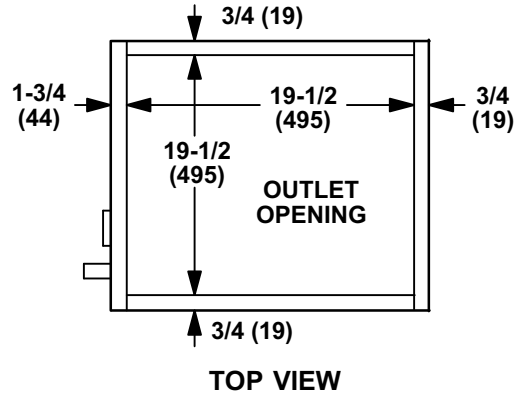

Model No.	A		B		C	
	in.	mm	in.	mm	in.	mm
C33-49C-2F	15-7/8	403	18-3/4	476	29-1/2	749
C33-62C-2F	18-7/8	479	21-7/8	556	31-1/2	800

Dimensions - Inches (MM)

CX34-18/24, -30, -36, -38 and -42B Coils

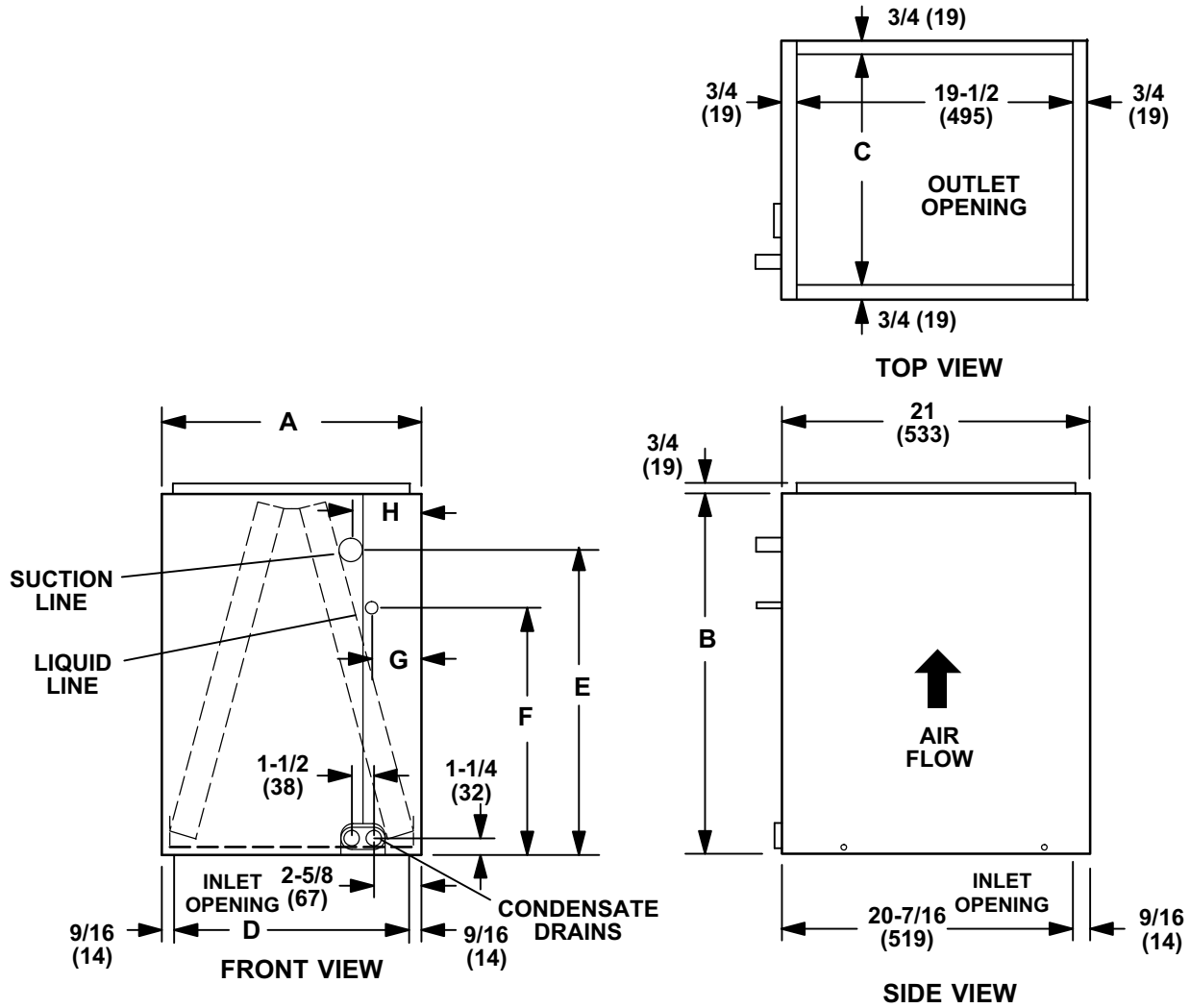

Model No.	A		B		C		D		E		F		G		H	
	in.	mm	in.	mm	in.	mm	in.	mm	in.	mm	in.	mm	in.	mm	in.	mm
CX34-18/24A-6F	14-1/2	368	16-1/2	419	13	330	13-3/8	340	11-1/8	283	8-1/8	206	2-3/4	70	3-7/8	98
CX34-18/24B-6F	17-1/2	445	16-1/2	419	16	406	16-3/8	416	11-1/4	286	8-1/4	210	3	76	4-1/8	105
CX34-18/24C-6F	21	533	16-1/2	419	19-1/2	495	19-7/8	505	11-1/4	286	8-1/4	210	3	76	4-1/8	105
CX34-30A-6F	14-1/2	368	20-1/2	521	13	330	13-3/8	340	15-1/4	387	12-1/4	311	2-3/4	70	3-7/8	98
CX34-30B-6F	17-1/2	445	20-1/2	521	16	406	16-3/8	416	15-1/4	387	12-1/4	311	3	76	4-1/8	105
CX34-30C-6F	21	533	20-1/2	521	19-1/2	495	19-7/8	505	15-1/4	387	12-1/4	311	3	76	4-1/8	105
CX34-36A-6F	14-1/2	368	24-1/2	622	13	330	13-3/8	340	19-1/4	489	16-3/8	416	2-3/4	70	3-7/8	98
CX34-36B-6F	17-1/2	445	24-1/2	622	16	406	16-3/8	416	18-5/8	473	15-5/8	397	3	76	4-1/8	105
CX34-36C-6F	21	533	24-1/2	622	19-1/2	495	19-7/8	505	19-5/8	498	16-5/8	422	4-3/4	121	3-5/8	92
CX34-38A-6F	14-1/2	368	24-1/2	622	13	330	13-3/8	340	18-1/8	464	15-3/8	391	2-3/4	70	3-7/8	98
CX34-38B-6F	17-1/2	445	24-1/2	622	16	406	16-3/8	416	18-3/8	467	15-1/2	394	2-3/4	70	3-7/8	98
CX34-42B-6F	17-1/2	445	24-1/2	622	16	406	16-3/8	416	18-5/8	467	15-5/8	397	3	76	4-1/8	105

Dimensions - Inches (MM)

CX34-19A, -25, -31, -43, -44/48, -50/60C, -60D and -62D Coils

(NOTE - See next page for CX34-49C-6F and CX34-62C-6F Coils)

NOTE- CX34-60D and CX34-62D coils are positioned in cabinet with coil face running left to right, all other coil sizes are positioned like drawing.

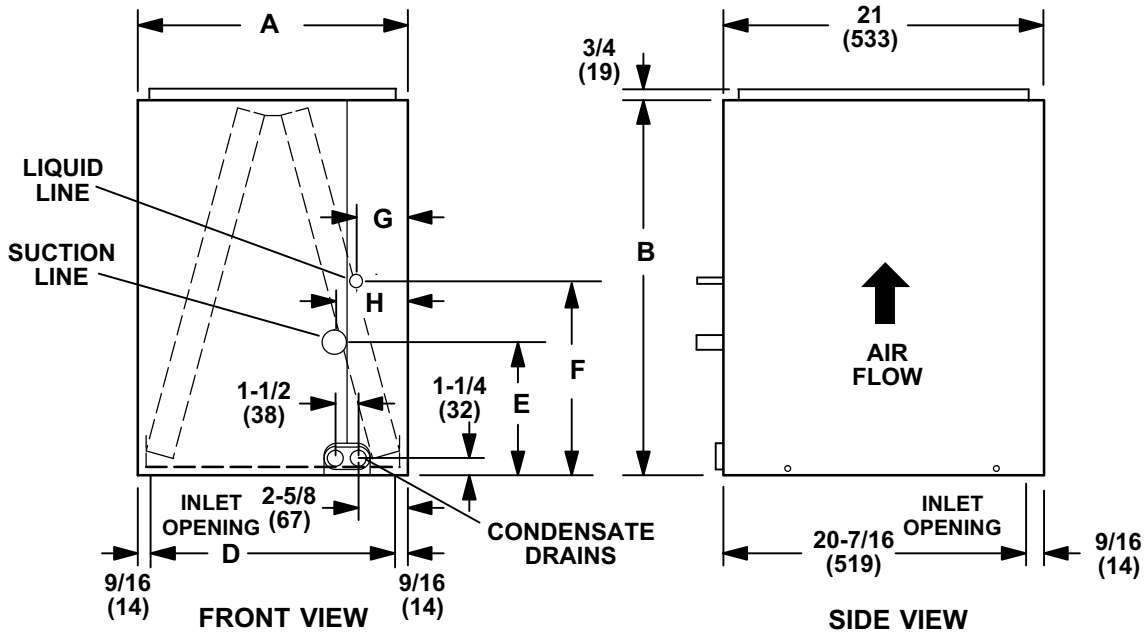
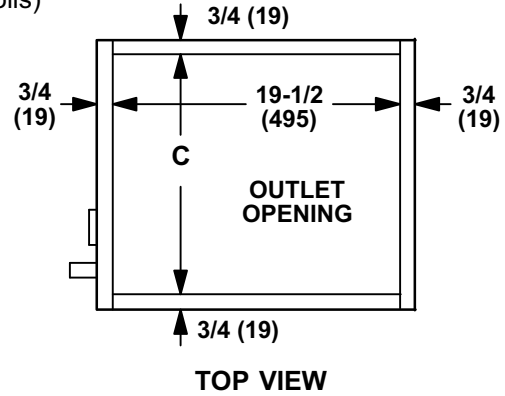

Model No.	A		B		C		D		E		F		G		H	
	in.	mm	in.	mm	in.	mm	in.	mm	in.	mm	in.	mm	in.	mm	in.	mm
CX34-19A-6F	14-1/2	368	16-1/2	419	13	330	13-3/8	340	10-7/8	276	13-7/8	353	3	76	3-7/8	98
CX34-25A-6F	14-1/2	368	18-1/2	470	13	330	13-3/8	340	12-7/8	327	15-7/8	403	3	76	3-7/8	98
CX34-25B-6F	17-1/2	445	18-1/2	470	16	406	16-3/8	416	12-7/8	327	15-7/8	403	3-1/4	83	4-1/8	105
CX34-31A-6F	14-1/2	368	22-1/2	572	13	330	13-3/8	340	12-3/8	314	15-3/8	391	1-1/2	38	2-3/8	60
CX34-31B-6F	17-1/2	445	22-1/2	572	16	406	16-3/8	416	12-3/8	314	15-3/8	391	3-1/4	83	4-1/8	105
CX34-43B-6F	17-1/2	445	27-1/2	699	16	406	16-3/8	416	16-3/4	425	19-3/4	502	3-1/4	83	4-1/8	105
CX34-43C-6F	21	533	27-1/2	699	19-1/2	495	19-7/8	505	16-3/4	425	19-3/4	502	2-3/4	70	3-5/8	92
CX34-44/48B-6F	17-1/2	445	24-1/2	622	16	406	16-3/8	416	9-3/4	248	12-3/4	324	3	76	4-1/8	105
CX34-44/48C-6F	21	533	24-1/2	622	19-1/2	495	19-7/8	505	12-3/4	324	15-3/4	400	4-1/4	108	5-3/8	137
CX34-50/60C-6F	21	533	27-1/2	699	19-1/2	495	19-7/8	505	16-1/2	419	19-1/2	495	2-1/2	64	3-5/8	92
CX34-60D-6F	24-1/2	622	25-1/2	648	23	584	23-3/8	594	11-7/8	302	14-7/8	518	1-5/8	41	2-3/4	70
CX34-62D-6F	24-1/2	622	29-1/2	749	23	584	23-3/8	594	18-7/8	479	21-7/8	556	1-5/8	41	2-3/4	70

Dimensions - Inches (MM)

CX34-49C-6F and CX34-62C-6F

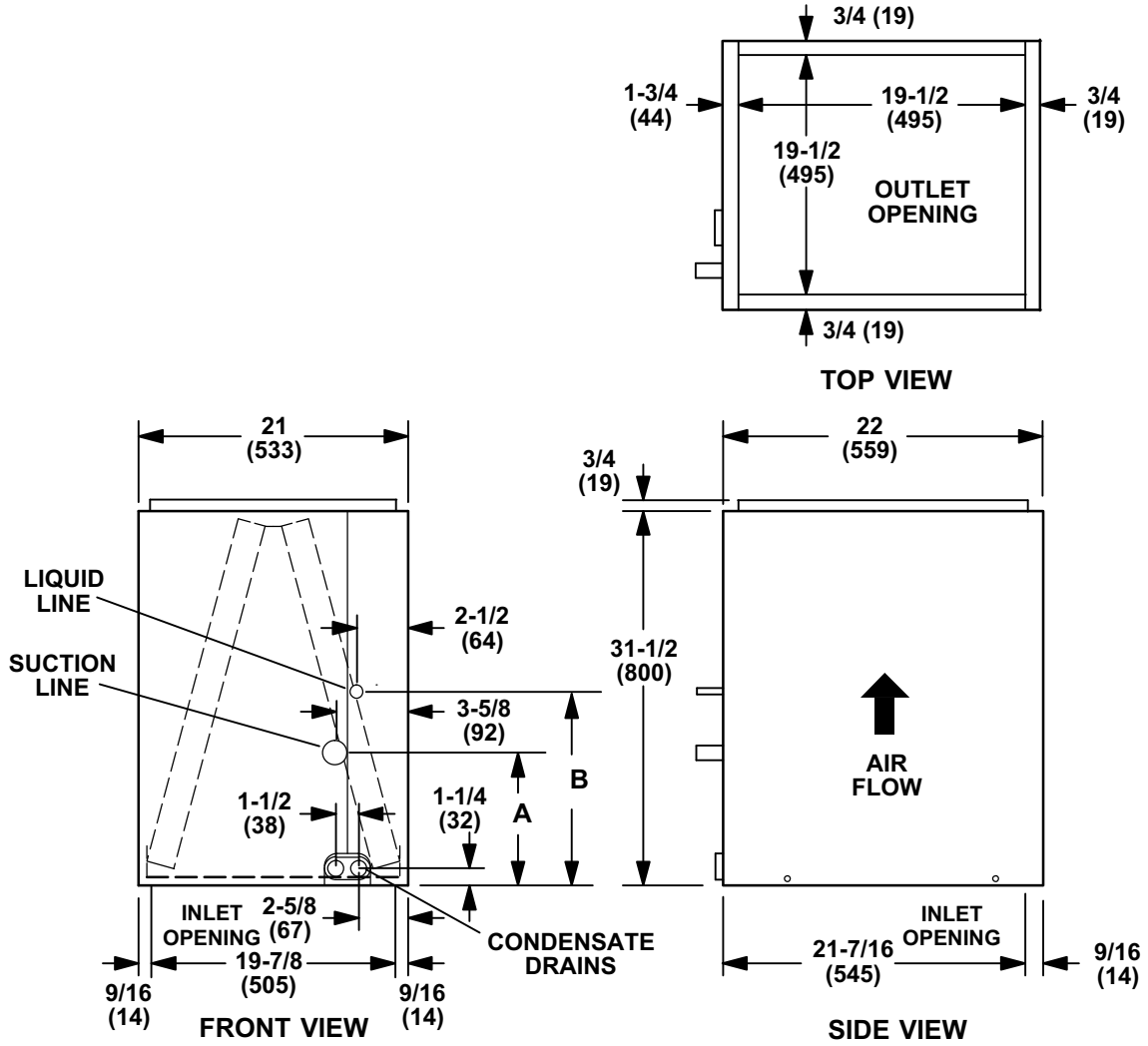

Model No.	A		B	
	in.	mm	in.	mm
CX34-49C-6F	15-7/8	403	18-3/4	476
CX34-62C-6F	18-7/8	479	21-7/8	556

C33 Optional Adjustable Coil Adaptor / Seal Applications

C33-18A through C33-62C Uncased Coils

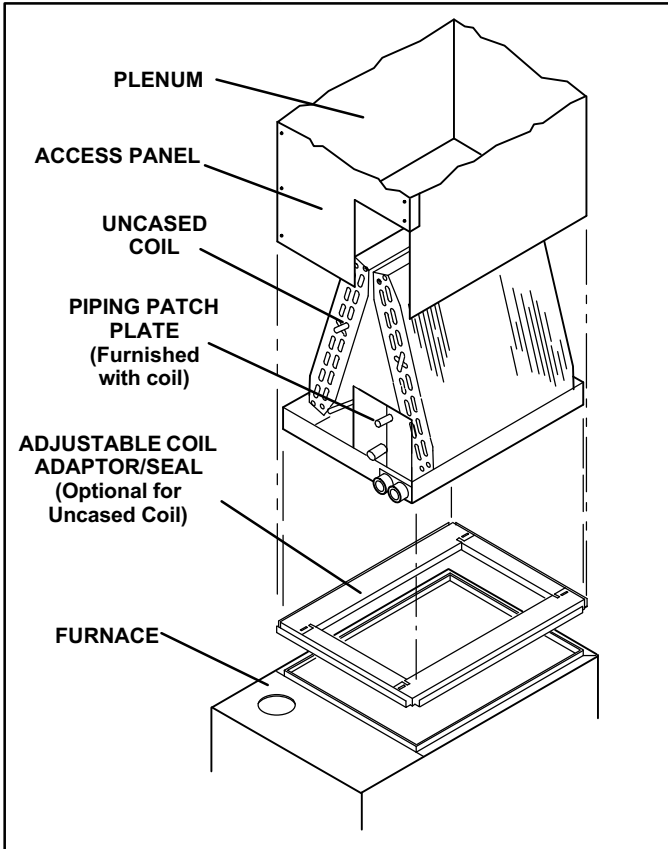

C33-60D and C33-62D Uncased Coils

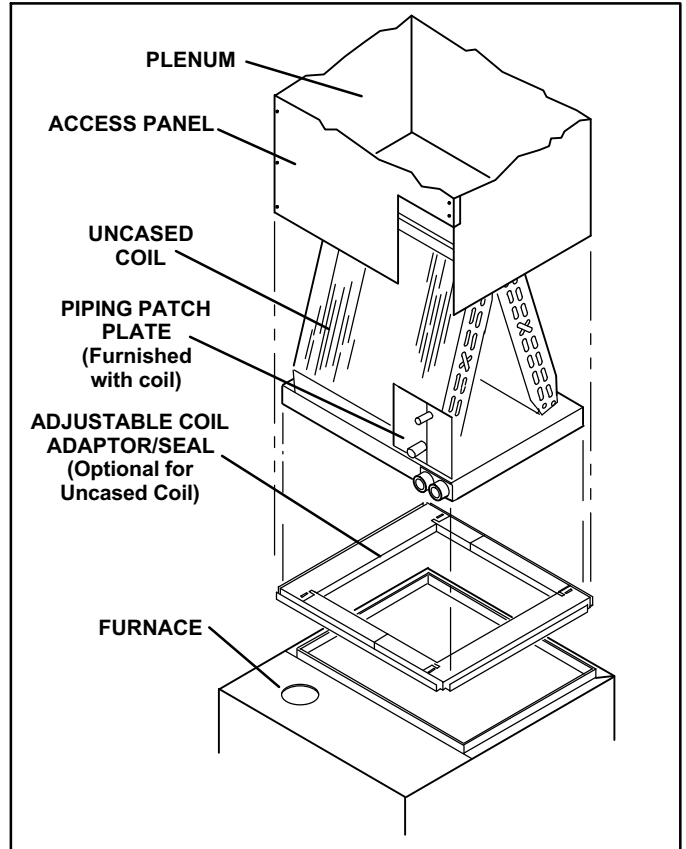

ADJUSTABLE COIL ADAPTOR/SEAL DIMENSIONS — inches

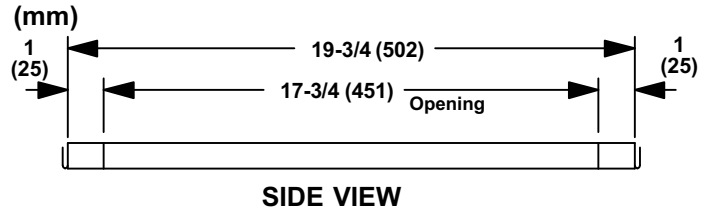
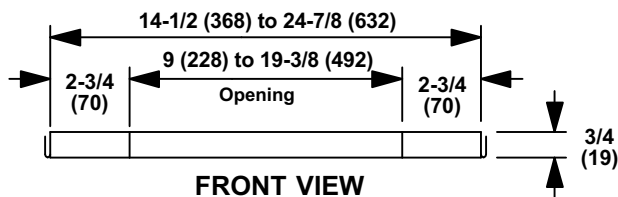

ADJUSTABLE COIL ADAPTOR/SEAL DETAIL

Frame Telescopes To Accommodate Various Furnace Openings

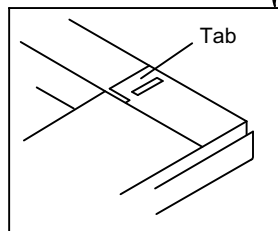
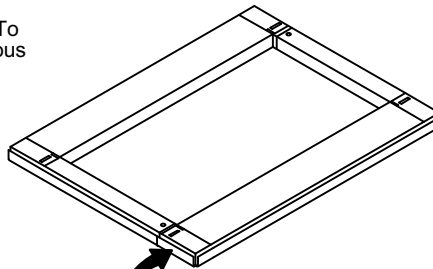

Tab may be bent up 90° for centering of smaller coils.

Table 1. Orifice Size Shipped with C33 Units

Model C33 (Case/ and Uncase)	Orifice Size
C33-18A-2 / (2-F)	0.051
C33-19A-2 / (2-F)	0.051
C33-24A-2 / (2-F)	0.057
C33-24B-2 / (2-F)	0.057
C33-24C-2 / (2-F)	0.057
C33-25A-2 / (2-F)	0.057
C33-25B-2 / (2-F)	0.057
C33-30A-2 / (2-F)	0.065
C33-30B-2 / (2-F)	0.065
C33-30C-2 / (2-F)	0.065
C33-31A-2 / (2-F)	0.065
C33-31B-2 / (2-F)	0.065
C33-36A-2 / (2-F)	0.073
C33-36B-2 / (2-F)	0.073
C33-36C-2 / (2-F)	0.073
C33-38A-2 / (2-F)	0.073
C33-38B-2 / (2-F)	0.073
C33-42B-2 / (2-F)	0.076
C33-43B-2 / (2-F)	0.076
C33-43C-2 / (2-F)	0.076
C33-44C-2 / (2-F)	0.076
C33-48B-2 / (2-F)	0.082
C33-48C-2 / (2-F)	0.082
C33-49C-2 / (2-F)	0.082
C33-50/60C-2 / (2-F)	0.082
C33-60D-2 / (2-F)	0.093
C33-62C-2 / (2-F)	0.093
C33-62D-2 / (2-F)	0.093

Releasing Air Charge

⚠ CAUTION

The coil is shipped from the factory pressurized with dry air. Pierce a hole in the coil's rubber plug vapor line seal to relieve the pressure before removing the seals.

⚠ IMPORTANT

During installation and after servicing or maintenance, ensure that the distributor lines are not rubbing together or kinked. All tubes must have enough clearance from other metal parts. Secure tubes with wire ties to prevent movement.

Wires should never touch or be secured to refrigerant lines that will contain hot gas in certain system modes.

NOTE - If there is no pressure release when the coil's liquid line rubber plug seal is pierced, check the coil for leaks before continuing with the installation.

The C33 and CX34 coils are shipped with a 10 ± 3 psi dry air holding charge. Ensure that the coil is void of pressure.

Unit Installation

⚠ WARNING

Risk of explosion or fire.

Can cause injury or death.

Recover all refrigerant to relieve pressure before opening the system.

Install the furnace or air handler according to the installation instructions provided with the unit.

Cased C33 or CX34 Coils - Position the cased coil on top of the furnace or air handler cabinet and secure it using field-provided screws.

NOTE - Cased coils have six screw clearance holes which should be aligned with the furnace engagement holes. Secure the coil casing to the furnace using six field-provided #8 X 1" screws.

NOTE - An optional adapter base (ordered separately) is available for use with uncased coils. Order Catalog Number 81J46 for a single adapter as illustrated in figure 1, and 11L09 for a package of 10 adapters.

NOTE - Figure 2 illustrates how to place the uncased coil into the air duct.

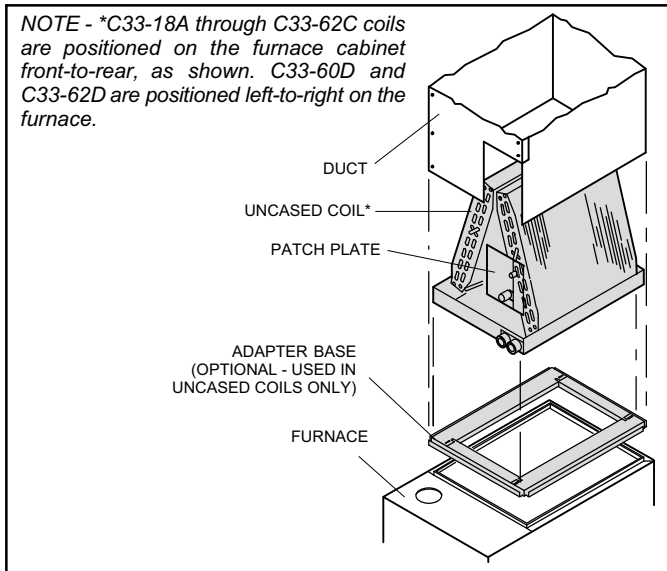

Figure 1. Adapter Base

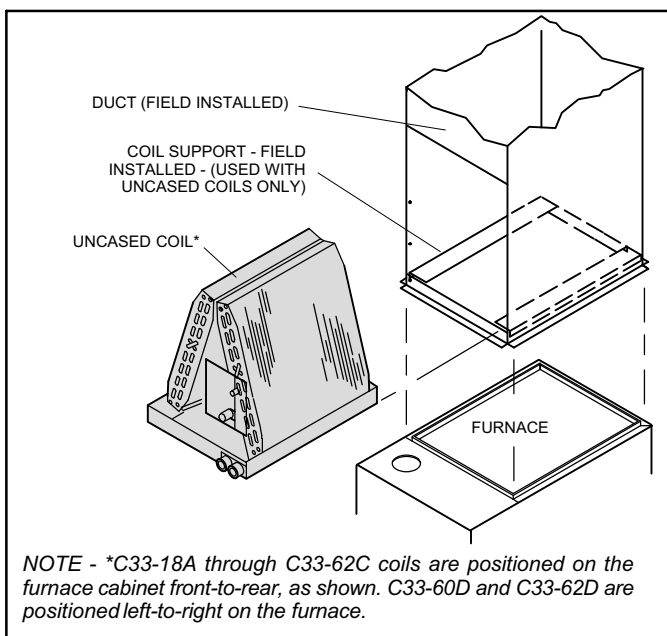

Figure 2. Field-Installed Coil Support

Installing Patch Plate (Uncased Coils Only - C33) - A two-piece patch plate and metering device label are provided (taped to the top of the coil). To install the plate:

NOTE - Either models (C33 or CX34) could be configured as illustrated in either figure 11 or 12.

1. Carefully pull the orifice housing forward through the patch plate opening in the plenum. **Do not twist, kink or damage the distributor tubes.** Use wire ties to secure tubes to prevent movement that could cause the refrigerant tubing to fail. Adjust the tubes if necessary as illustrated in figures 3 and 4.

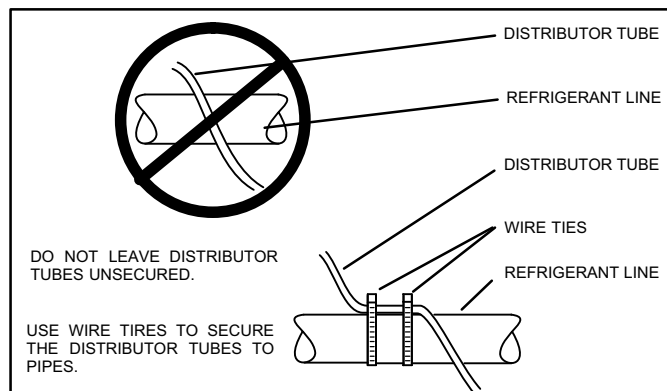

Figure 3. Secure Distributor Tubes to Pipes

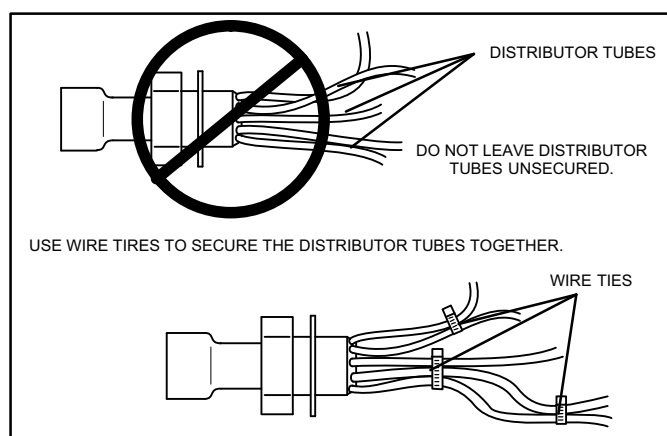

Figure 4. Secure Distributor Tubes Together

2. Position the orifice housing with the patch plate as illustrated in either figure 11 or 12. Carefully install two #8 X 1/2" sheet metal screws through the patch plate into the orifice housing mounting base. The distributor lines must not be twisted or kinked.
3. Install the patch plate onto the plenum.
4. Affix metering device label to front of plenum.

Refrigerant Line Set

The refrigerant line sets should be sized according to the recommendations given in the air conditioner unit installation instructions. Use either table 2 or 3 to determine correct braze connection sizes. A field-provided adapter may be required to match line set connections.

Table 2. Refrigerant Line Connections - Model C33

Model Number	Suction	Liquid
18-2(F) 19-2(F) 24-2(F), -24C-2, -24C-2(F) 25-2(F) 30-2(F), -30C-2, -30C-2(F) 31-2(F) 36-2(F) 38-2(F)	Line Sweat Size - 3/4 Inch (19mm)	Line Sweat Size - 3/8 Inch (9.5mm)
42-2(F) 43-2(F) 44-2(F) 48-2(F) 49-2(F) 60/60-2(F) 60-2(F) 62C-2(F) 62-2(F)	Line Sweat Size - 7/8 Inch (22mm)	

Table 3. Refrigerant Line Connections - Model CX34

Model Number	Suction	Liquid
18/24-6F 19-6(F) 24-6(F), -24C-6(F) 25-6(F) 30-6F, -30C-6(F) 31-6(F) 36-6(F) 38-6(F)	Line Sweat Size - 3/4 Inch (19mm)	Line Sweat Size - 3/8 Inch (9.5mm)
42-6(F) 43-6(F) 44/48-6(F) 49-6(F) 50/60-6(F) 60-6(F) 62-6(F), -62C-6(F)	Line Sweat Size - 7/8 Inch (22mm)	

Replacement Parts

If replacement parts are necessary, order kit 69J46. The kit includes:

- 10 — Brass nuts for liquid line assemblies
- 20 — Teflon® rings
- 10 — Liquid line orifice housings
- 10 — Liquid line assemblies

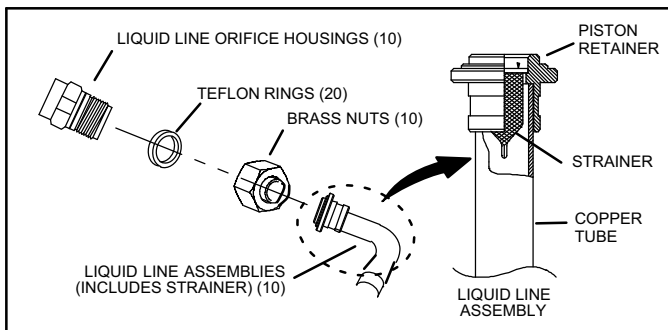

Figure 5. 69J46 Kit Components

Connections

Use a silver alloy brazing rod (5 or 6 percent silver alloy for copper-to-copper connections or 45 percent silver alloy for copper-to-brass or copper-to-steel connections).

C33/CX34 — BRAZE SUCTION/VAPOR LINE

Use the following procedure to connect the vapor line to the indoor coil unit:

1. Remove rubber plug.
2. Place a field-provided heat shield, such as a wet rag, against the piping plate and around the piping stubs, and sweat in the suction line. The heat shield must be in place to protect the paint from heat damage.
3. Braze connection.
4. Remove the heat shield after brazing and allow the connections to cool.

C33 — SUCTION/VAPOR LINE

The following procedures must be performed:

1. Expansion Valve Applications: Remove the copper flare seat bonnet if present from the male equalizer line fitting (see figure 6).
2. RFC Applications: Remove flare seal cap or flare nut and remove copper seal bonnet if present. Install field-provided Schrader® valve, reinstall copper seal bonnet if removed earlier and flare nut / flare seal cap.

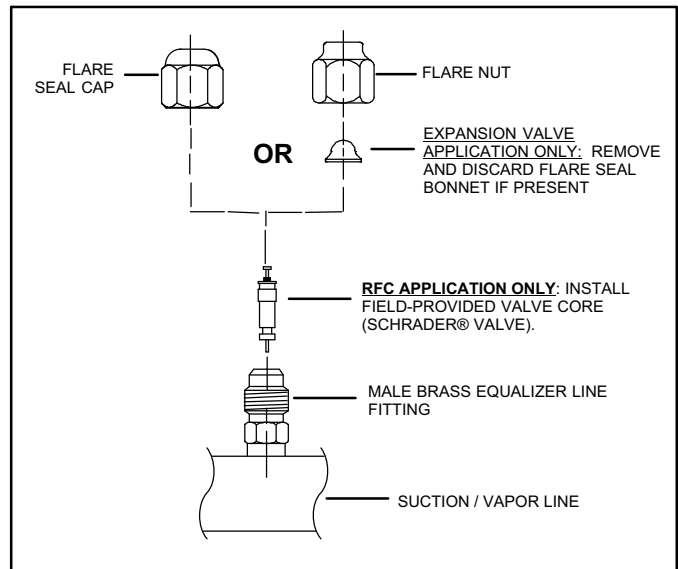

Figure 6. Male Equalizer Line Fitting Modifications

C33 — CONNECT LIQUID LINE

Use the following procedure to connect the liquid line to the indoor coil unit:

1. Slide the liquid line compression nut onto the provided liquid line fitting (the liquid line fitting comes attached to the front of the delta plate of the uncased coils).
2. Insert the field-supplied liquid line into the liquid line stub for brazing.

CX34 — CONNECT LIQUID LINE

Use the following procedure to connect the liquid line to the indoor coil unit. Connect the field-provided liquid line to the liquid line of the cased coil as illustrated in figure 7 using one of the following procedures:

1. Place a field-provided heat shield, such as a wet rag, against the piping plate and around the piping stubs, and braze in the liquid line. The heat shield must be in place to protect the metering device from heat damage.
2. Remove the heat shield after brazing and allow the connections to cool.

OR

3. Cut the copper liquid line on a vertical or horizontal section. Use a field-provided coupling to join the field liquid line and coil liquid line connections.
4. Remove the heat shield after brazing and allow the connections to cool.

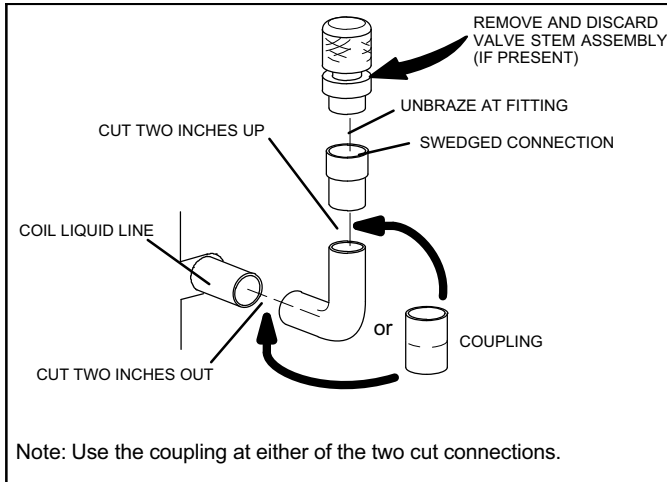

Figure 7. Liquid Line Connections

Refrigerant Metering Device

Below are the factory-installed metering devices and optional metering devices if applicable to both types of coils.

- The C33 coil is shipped with a factory-installed fixed orifice. C33 cased and uncased coils are compatible with either HFC-410A fixed orifice, expansion or check expansion valve metering devices.
- CX34 cased coil have factory-installed HFC-410A check expansion valve metering device.

The previously reference expansion or check expansion metering devices will be referred to in this instruction as expansion valve.

DETERMINING CORRECT FIXED ORIFICE (RFC)

A properly sized fixed orifice may be provided with the outdoor unit. Refer to the outdoor unit instruction to ensure proper sizing of the refrigerant flow control orifice. An improperly sized RFC orifice can lead to diminished capacities and/or efficiencies, as well as potential damage to the unit. RFCs shipped with the coils are identified in table 1.

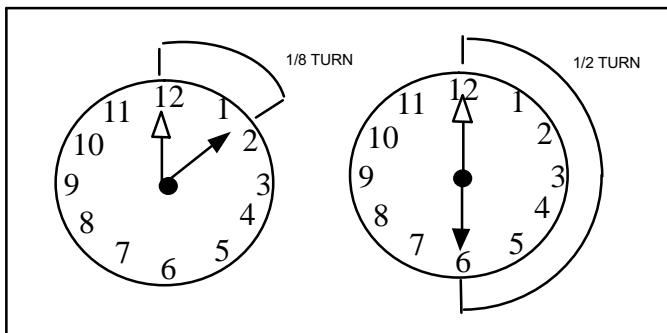

Figure 8. Tightening Distance

C33 - Typical Fixed Orifice Removal Procedure

1. On fully cased coils, remove the coil access and plumbing panels.
2. Remove any shipping clamps holding the liquid line and distributor assembly.
3. Using two wrenches, disconnect liquid line from distributor. Take care not to twist or damage distributor tubes during this process.
4. Remove and discard orifice, valve stem assembly if present and Teflon ring as illustrated in figure 9.
5. Retain brass nut to be using later with the liquid line assembly.

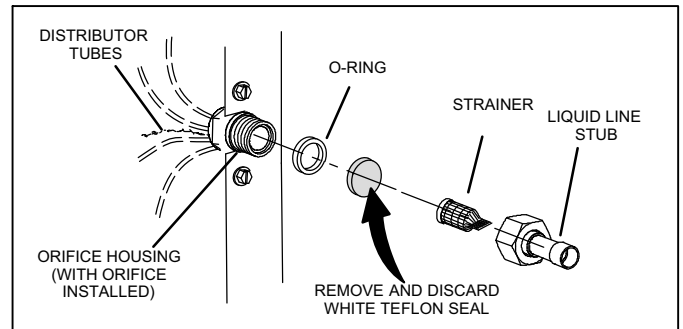

Figure 9. Typical Fixed Orifice Removal

C33 - Typical Fixed Orifice Installation Procedure

1. Ensure that the orifice is installed with the nylon seat pointing toward the liquid line orifice housing.
2. Insert the Teflon ring securely into the liquid line orifice housing. Lightly lubricate the threads of the liquid line orifice housing and the expose surface of the Teflon ring.
3. Connect the liquid line assembly with the brass nut to the liquid line orifice housing. Finger tighten and use an appropriately sized wrench to turn an additional 1/2 turn clockwise as illustrated in figure 8, or 20 ft-lb.
4. Place the supplied fixed orifice sticker on the indoor cabinet after installation.

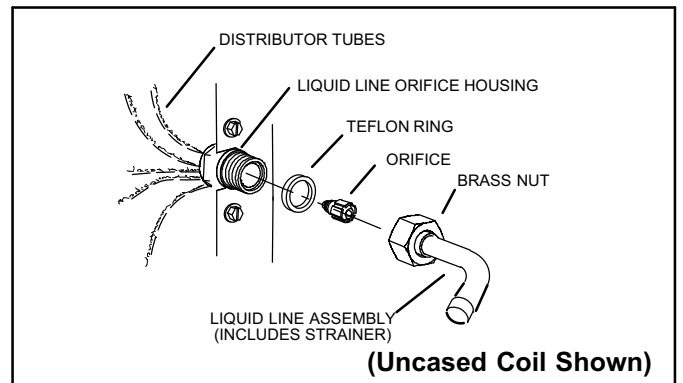

Figure 10. Typical Fixed Orifice Installation

C33 - TYPICAL TXV INSTALLATION PROCEDURE

The TXV unit can be installed internal or external to the indoor coil. In applications where an uncased coil is being installed in a field-provided plenum, install the TXV in a manner that will provide access for field servicing of the TXV. Refer to figures 11 or 12 for reference during installation of TXV unit.

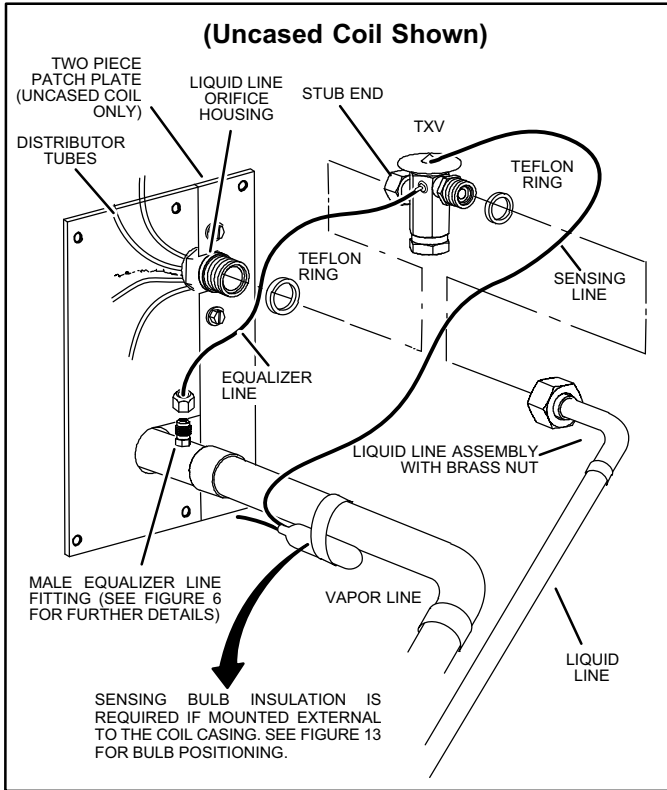

Figure 11. Patch Plate (Configuration A)

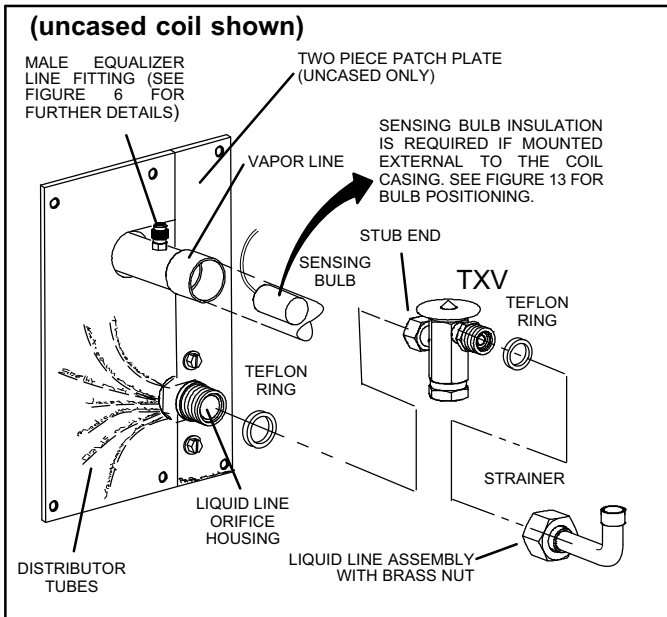

Figure 12. Patch Plate (Configuration B)

1. Insert one of the provided Teflon rings into the stubbed end of the TXV. Lightly lubricate the threads of the stubbed end of the TXV and the expose surface of the Teflon ring.
2. Attach the stubbed end of the TXV to the liquid line orifice housing. Finger tighten and use an appropriately sized wrench to turn an additional 1/2 turn clockwise as illustrated in figure 8, or 20 ft-lb.
3. Place the remaining Teflon washer around the other end of the TXV and lightly lubricate the threads of the that end of the TXV, and the expose surface of the Teflon ring.
4. Attach the liquid line assembly with brass nut to the TXV. Finger tighten and use an appropriately sized wrench to turn an additional 1/2 turn clockwise as illustrated in figure 8, or 20 ft-lb.
5. Attach the sensing bulb of the TXV in the proper orientation as illustrated in figure 13 to the suction line using the clamp and screws provided.

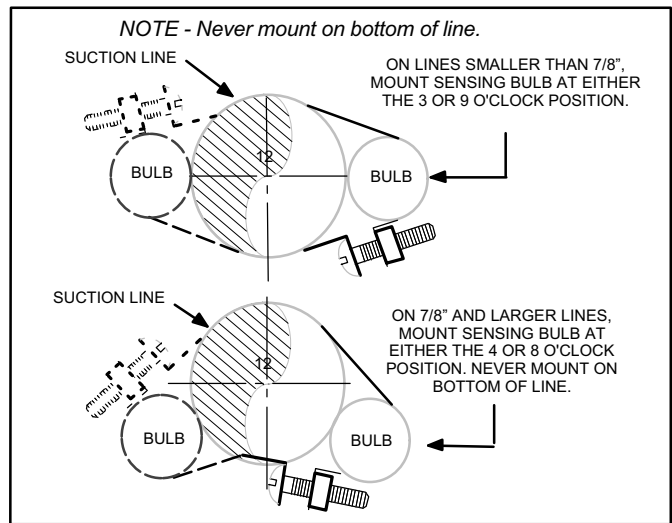

Figure 13. TXV Sensing Bulb Installation

NOTE - To prevent any possibility of water damage, properly insulate all parts of the TXV assembly that may sweat due to temperature differences between the valve and its surrounding ambient temperatures.

6. Connect the equalizer line from the TXV to the equalizer suction port on the suction line. Finger tighten the flare nut plus 1/8 turn (7 ft-lbs) as illustrated in figure 8 on page 15.

⚠ IMPORTANT

When removing the flare nut, ensure that the copper flare seal bonnet is removed as illustrated in figure 6.

See the C33/CX34 Engineering Handbook for approved TXV match-ups and application information. Typically, the TXV kits include the following:

- 1 — TXV
- 2 — Teflon rings
- 1 — 1 1/4" wide copper mounting strap for sensing bulb
- 2 — #10 hex head bolts and nuts for securing sensing bulb

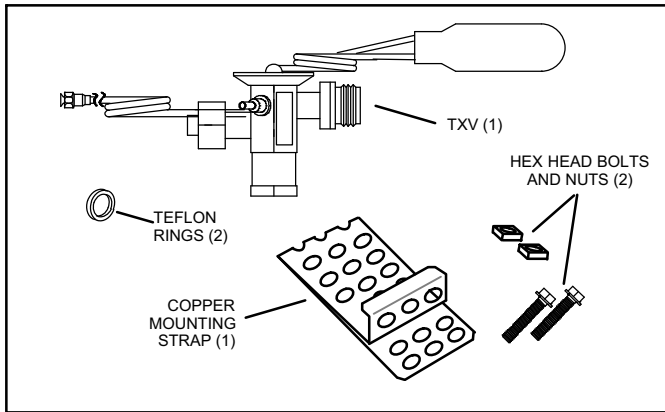

Figure 14. TXV Kit Components

Leak Testing, Evacuating and Charging

Refer to the outdoor unit instruction for leak testing, evacuating and charging procedures. Always leak check entire system before charging.

Sealing Ducts

⚠ WARNING

There must be an airtight seal between the bottom of the furnace and the return air plenum. Use fiberglass sealing strips, caulking, or equivalent sealing method between the plenum and the air handler cabinet to ensure a tight seal. Return air must not be drawn from a room where this air handler or any gas-fueled appliance (i.e., water heater), or carbon monoxide-producing device (i.e., wood fireplace) is installed.

Ensure the duct is secured and all joints are properly sealed to either the coil cabinet flanges (fully cased models) or the furnace cabinet flanges (uncased models).

Condensate Drain Connections

⚠ IMPORTANT

After removal of drain pan plug(s), check drain hole(s) to verify that drain opening is fully open and free of any debris. Also check to make sure that no debris has fallen into the drain pan during installation that may plug up the drain opening.

MAIN DRAIN

Connect the main drain and route downward to drain line or sump. Do not connect drain to a closed waste system. See Figure 15 for typical drain trap configuration.

OVERFLOW DRAIN

It is recommended that the overflow drain is connected to a overflow drain line for all units. If overflow drain is not connected, it must be plugged with provided cap.

BEST PRACTICES

The following best practices are recommended to ensure better condensate removal:

- Main and overflow drain lines should **NOT** be smaller than both drain connections at drain pan.
- Overflow drain line should run to an area where homeowner will notice drainage.
- It is recommended that the overflow drain line be vented and a trap installed. Refer to local codes.

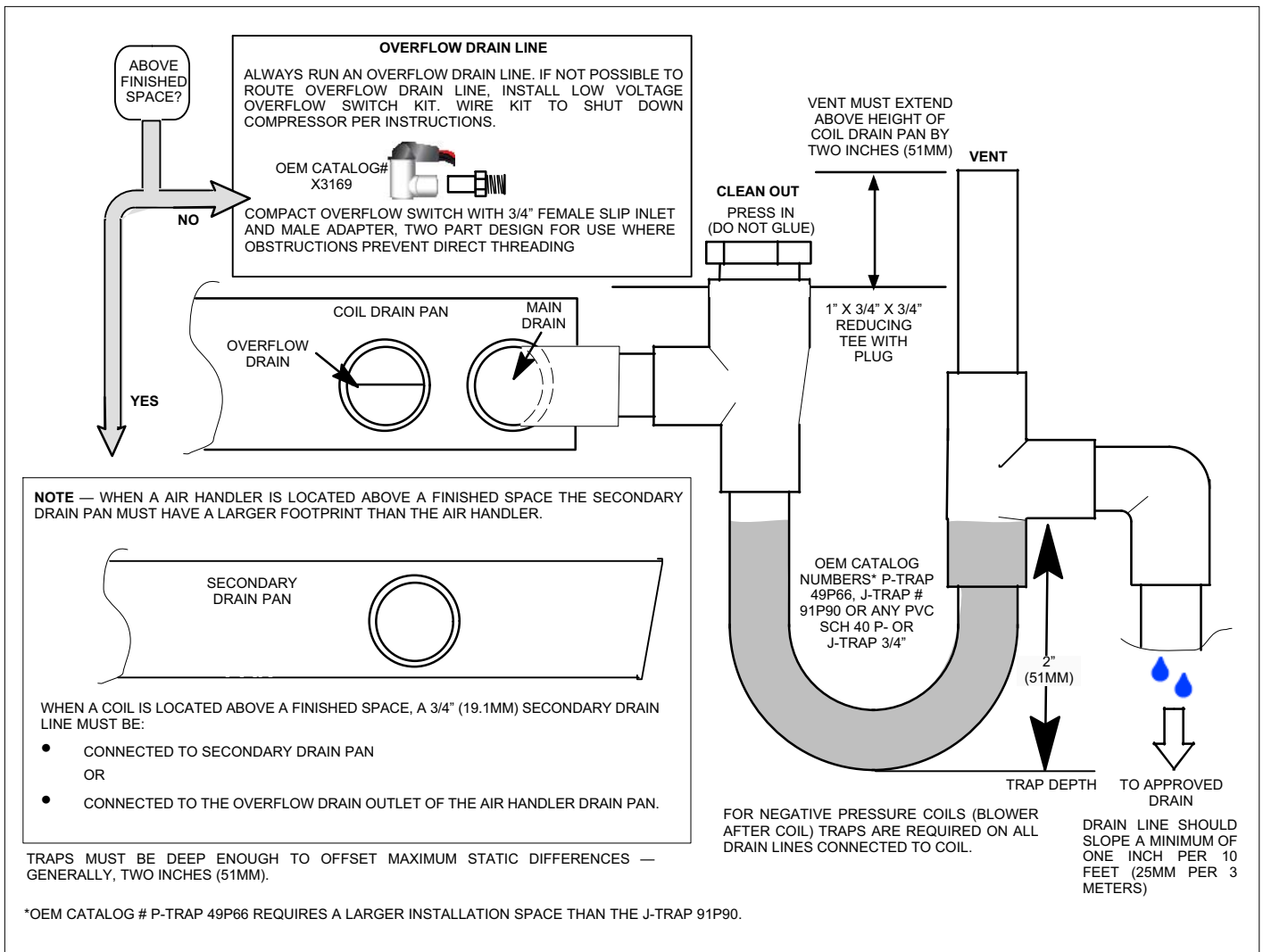

Figure 15. Typical Main and Overflow Drain Installations

Blower Speed Connection

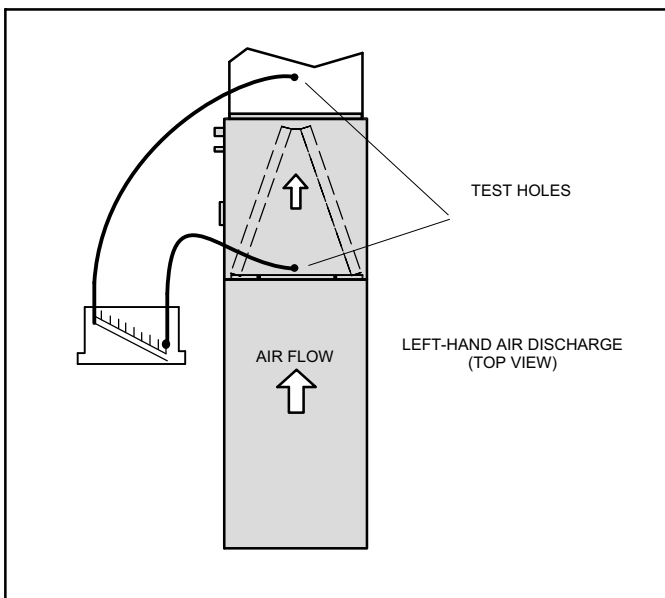

Figure 16. Static Pressure Test

CAUTION

Take care when drilling test holes into the furnace flange and the duct. Drill holes away from refrigerant piping. Test holes should be drilled where specified in order to avoid unit damage.

Proper air volume must be provided over the evaporator coil. Select a blower motor speed tap that will provide 400 ± 50 CFM per 12,000 Btu/h of cooling capacity (wet coil). A static pressure reading must be taken to see if the pressure drop falls within the proper range.

To ensure accuracy, air must be read from below the coil and above the coil. See figure 16 for an example to obtain an accurate reading.

1. Drill one 5/16" (8 mm) air test hole into the delta plate between the coil slabs.
2. Drill one 5/16" (8 mm) air test hole into the duct above the top of the coil.
3. Connect the **instrument for static pressure measurement hoses** to the air entering side of coil. Insert the hoses so that 1/4" (6 mm) extends inside the duct or end seal. Seal around holes with Permagem®.

4. Turn on electrical power to the furnace and set the thermostat to initiate a cooling demand.
5. Tables 4 and 5 lists the range of air volumes and equivalent static pressure readings for these units. Observe the static pressure reading. If the reading is below the required air volume, increase the blower speed; if the reading is above the required air volume, decrease the blower speed. Refer to the furnace wiring diagram for blower speed settings.
6. When the required static pressure readings are obtained, remove the test hose lines and insert snap hole plugs into test holes.

Table 4. Air Volume / Static Pressure Drop Across Coil - Model C33

Cabinet		Vol: CFM (L/s)	Drop: in. w.g. (Pa)	
Model	Width in. (mm)		Dry	Wet
18A-2(F)	14-1/2 (394)	600 (285)	.14 (35)	.17 (42)
19A-2(F)	14-1/2 (394)	600 (285)	.08 (20)	.09 (22)
24A-2(F) 24B-2(F)	14-1/2 (394) 17-1/2 (444)	800 (380)	.18 (45)	.25 (62)
24C-2(F)	21 (533)	800 (380)	.16 (40)	.22 (55)
25A-2(F)	14-1/2 (394)	800 (380)	.16 (40)	.22 (55)
25B-2(F)	17-1/2 (444)	800 (380)	.11 (27)	.15 (37)
30C-2(F)	21 (533)	1000 (470)	.20 (50)	.28 (70)
30A-2(F) 30B-2(F)	14-1/2 (394) 17-1/2 (444)	1000 (470)	.22 (55)	.30 (75)
31A-2(F)	14-1/2 (394)	1000 (470)	.18 (45)	.20 (50)
31B-2(F)	17-1/2 (444)	1000 (470)	.13 (32)	.16 (40)
36A-2(F)	14-1/2 (394)	1200 (565)	.27 (67)	.30 (75)
36B-2(F)	17-1/2 (444)	1200 (565)	.17 (42)	.21 (52)
38A-2(F)	14-1/2 (394)	1200 (565)	.27 (67)	.30 (75)
38B-2(F)	17-1/2 (444)	1200 (565)	.17 (42)	.21 (52)
36C-2(F)	21 (533)	1200 (565)	.17 (42)	.21 (52)
42B-2(F)	17-1/2 (444)	1400 (660)	.22 (55)	.28 (70)
43B-2(F)	17-1/2 (444)	1400 (660)	.23 (57)	.24 (60)
43C-2(F)	21 (533)	1400 (660)	.13 (32)	.16 (40)
44C-2(F)	21 (533)	1400 (660)	.18 (45)	.23 (57)
48B-2(F)	17-1/2 (444)	1600 (755)	.17 (42)	.21 (52)
48C-2(F)	21 (533)	1600 (755)	.23 (57)	.29 (72)
49C-2(F)	21 (533)	1600 (755)	.17 (42)	.22 (55)
50/60C-2(F)	21 (533)	1600 (755)	.23 (57)	.29 (72)
60D-2(F)	24-1/2 (622)	2000 (945)	.21 (52)	.27 (67)
62C-2(F)	24-1/2 (622)	2000 (945)	.29 (72)	.34 (85)
62D-2(F)	24-1/2 (622)	2000 (945)	.21 (52)	.27 (67)

Table 5. Air Volume / Static Pressure Drop Across Coil - Model CX34

Cabinet		Vol: CFM (L/s)	Drop: in. w.g. (Pa)	
Model	Width in. (mm)		Dry	Wet
18/24A-6(F)	14-1/2 (394)	800 (380)	.18 (45)	.25 (62)
19A-6(F)	14-1/2 (394)	600 (285)	.08 (20)	.09 (22)
24B-6(F)	17-1/2 (444)	800 (380)	.18 (45)	.25 (62)
24C-6(F)	21 (533)	800 (380)	.16 (40)	.22 (55)
24B-6(F)	21 (533)	1000 (470)	.20 (50)	.28 (70)
25A-6(F)	14-1/2 (394)	800 (380)	.16 (40)	.22 (55)
25B-6(F)	17-1/2 (444)	800 (380)	.11 (27)	.15 (37)
30A-6(F) 30B-6(F)	14-1/2 (394) 17-1/2 (444)	1000 (470)	.22 (55)	.30 (75)
31A-6(F)	14-1/2 (394)	1000 (470)	.18 (45)	.20 (50)
31B-6(F)	17-1/2 (444)	1000 (470)	.13 (32)	.16 (40)
36A-6(F)	14-1/2 (394)	1200 (565)	.27 (67)	.30 (75)
36B-6(F)	17-1/2 (444)	1200 (565)	.17 (42)	.21 (52)
38A-6(F)	14-1/2 (394)	1200 (565)	.27 (67)	.30 (75)
38B-6(F)	17-1/2 (444)	1200 (565)	.17 (42)	.21 (52)
36C-6(F)	21 (533)	1200 (565)	.17 (42)	.21 (52)
42B-6(F)	17-1/2 (444)	1400 (660)	.22 (55)	.28 (70)
43B-6(F)	17-1/2 (444)	1400 (660)	.23 (57)	.24 (60)
43C-6(F)	21 (533)	1400 (660)	.13 (32)	.16 (40)
44/48C-6(F)	21 (533)	1400 (660)	.18 (45)	.23 (57)
48B-6(F)	17-1/2 (444)	1600 (755)	.17 (42)	.21 (52)
49C-6(F)	21 (533)	1600 (755)	.17 (42)	.22 (55)
50/60C-6(F)	21 (533)	1600 (755)	.23 (57)	.29 (72)
60D-6(F)	24-1/2 (622)	2000 (945)	.21 (52)	.27 (67)
62C-6(F)	24-1/2 (622)	2000 (945)	.29 (72)	.34 (85)
62D-6(F)	24-1/2 (622)	2000 (945)	.21 (52)	.27 (67)

Maintenance

⚠ CAUTION

A damaged coil fin can affect equipment operation and performance. Do not use flame, high-pressure water, steam, or volatile cleaners on fins or tubing surfaces. If cleaning requires the use of acidic or alkaline cleaners, follow the manufacturer's instructions. Thoroughly flush cleaner from all equipment components. (Be careful to prevent damage or corrosion of the components connected to the system or areas surrounding the equipment being cleaned.)

A trained technician or service agency must perform maintenance and service on equipment. At the beginning of each heating or cooling season, indoor coils should be cleaned.

Do not use hydrofluoric acid, alkaline, or similar chemicals on coils. These chemicals are not necessary to dissolve salt, and may damage the fin coating. Acid washes are used to dissolve oils and greases, which generally are not present on most installations.

Alkaline washes are useful for dissolving oxides such as zinc oxide, aluminum oxide, and iron oxide (rust). These three oxides are more corrosion-resistant than base metals, so dissolving or removing them will cause an increase in corrosion.

CLEANING THE COIL:

1. Remove the coil from the cabinet or plenum, and take the coil to an appropriate place to clean it.
2. Vacuum or brush the coil to remove matted and surface debris from the fin. Use vacuum attachments and /or brushes that are non-destructive to fins.
3. If oil deposits are present, spray the coil with ordinary household liquid detergent. Allow detergent to soften deposits and wait 10 minutes.

NOTE - For units in coastal regions, fresh water will dissolve away any salt deposits. (Wash coils with fresh water at least every six months.)

4. Spray the coil at a vertical angle of 30 to 45 degrees with a constant stream of water at moderate pressure.

A pressure washer with a fan nozzle will work best. Do not spray the coil from a horizontal direction.

5. Direct the spray so that any debris is washed out of the coil and base pan. For most residential units, hot water is not necessary.

NOTE - Attempting to back flush from the inside of the coil will require removing parts from the unit, and it may be very difficult to flush the whole coil surface. Attempting to blow water through a coil will slow the water stream and reduce the flushing action of the outer fin surface.

6. Replace the coil into the cabinet or plenum. Ensure that you have followed the proper procedure for routing and securing the refrigerant tubing.

IMPORTANT

Ensure that the distributor lines are not rubbing together or kinked. All tubes must have enough clearance from other metal parts. Use wire ties to secure tubes to prevent movement that could cause the refrigerant tubing to fail. Adjust the tubes as necessary as illustrated in figure 3 on page 13.

Wires should never touch or be secured to refrigerant lines that will contain hot gas in certain system modes.