

**INSTALLATION INSTRUCTIONS FOR CHECK / THERMOSTATIC EXPANSION VALVE
(CTXV) KITS (11X49, 11X50 and 11X51)**

**RETAIN THESE INSTRUCTIONS
FOR FUTURE REFERENCE**

Shipping and Packing List

Package 1 of 1 contains:

- Check / Thermostatic Expansion Valve (qty. 1)
- Bag assembly containing the following:
 - 1 - 1/2" x 3/8" coupling (P-8-5405)
 - 1 - Brass nut (25J8501)
 - 1 - Liquid line connector (44L3501)
 - 1 - Liquid line connector (83L9501)
 - 3 - Washers (25J8801)
- Installation instructions

⚠ WARNING

Improper installation, adjustment, alteration, service or maintenance can cause personal injury, loss of life, or damage to property.

Installation and service must be performed by a licensed professional HVAC installer (or equivalent) or a service agency.

NOTE - If replacement parts are necessary, order catalog number 69J46.

Check the package for shipping damage. If you find any damage, immediately contact the last carrier.

Application

This instruction is used to replace the existing outdoor unit metering device. This kit is for use with HFC-410A systems only.

TABLE 1. Emerson to Parker to Emerson Chatleff Kit Outdoor TXV Cross Reference

Heat Pump Model #	Emerson TXV			Parker TXV			Emerson TXV (Chatleff-Style Kit)			
	Cat. #	Part #	Nominal Capacity	Cat. #	Part #	Nominal Capacity	Cat. #	Kit Part #	TXV Part # in kit	Nominal Capacity
13HPX-018	88W50	103366-01	1.5	33W84	100481-14	1.5	11X49	614045-01	104449-01	1.5
13HPX-024	88W50	103366-01	1.5	33W84	100481-14	1.5	11X49	614045-01	104449-01	1.5
13HPX-030	88W51	103366-02	3	33W84	100481-14	1.5	11X50	614045-02	104449-02	3
13HPX-036	88W51	103366-02	3	33W85	100481-15	3	11X50	614045-02	104449-02	3
13HPX-042	88W52	103366-03	4	33W85	100481-15	3	11X51	614045-03	104449-03	4
13HPX-048	88W52	103366-03	4	33W85	100481-15	3	11X51	614045-03	104449-03	4
13HPX-060	88W52	103366-03	4	43W22	100481-16	5	11X51	614045-03	104449-03	4
14HPX-018	88W50	103366-01	1.5	33W84	100481-14	1.5	11X49	614045-01	104449-01	1.5
14HPX-024	88W50	103366-01	1.5	33W84	100481-14	1.5	11X49	614045-01	104449-01	1.5
14HPX-030	88W51	103366-02	3	33W84	100481-14	1.5	11X50	614045-02	104449-02	3
14HPX-036	88W51	103366-02	3	33W85	100481-15	3	11X50	614045-02	104449-02	3
14HPX-042	88W52	103366-03	4	33W85	100481-15	3	11X51	614045-03	104449-03	4
14HPX-048	88W52	103366-03	4	33W85	100481-15	3	11X51	614045-03	104449-03	4
14HPX-060	88W52	103366-03	4	33W85	100481-15	3	11X51	614045-03	104449-03	4
XP13-018	88W50	103366-01	1.5	33W84	100481-14	1.5	11X49	614045-01	104449-01	1.5
XP13-024	88W50	103366-01	1.5	33W84	100481-14	1.5	11X49	614045-01	104449-01	1.5
XP13-030	88W51	103366-02	3	33W84	100481-14	1.5	11X50	614045-02	104449-02	3
XP13-036	88W51	103366-02	3	33W85	100481-15	3	11X50	614045-02	104449-02	3
XP13-042	88W52	103366-03	4	33W85	100481-15	3	11X51	614045-03	104449-03	4
XP13-048	88W52	103366-03	4	33W85	100481-15	3	11X51	614045-03	104449-03	4
XP13-060	88W52	103366-03	4	43W22	100481-16	5	11X51	614045-03	104449-03	4
XP14-018	88W50	103366-01	1.5	33W84	100481-14	1.5	11X49	614045-01	104449-01	1.5
XP14-024	88W50	103366-01	1.5	33W84	100481-14	1.5	11X49	614045-01	104449-01	1.5
XP14-030	88W51	103366-02	3	33W84	100481-14	1.5	11X50	614045-02	104449-02	3
XP14-036	88W51	103366-02	3	33W85	100481-15	3	11X50	614045-02	104449-02	3
XP14-042	88W52	103366-03	4	33W85	100481-15	3	11X51	614045-03	104449-03	4
XP14-048	88W52	103366-03	4	33W85	100481-15	3	11X51	614045-03	104449-03	4
XP14-060	88W52	103366-03	4	33W85	100481-15	3	11X51	614045-03	104449-03	4
XP16-024	88W50	103366-01	1.5	33W84	100481-14	1.5	11X49	614045-01	104449-01	1.5
XP16-036	88W51	103366-02	3	33W85	100481-15	3	11X50	614045-02	104449-02	3
XP16-048	88W52	103366-03	4	33W85	100481-15	3	11X51	614045-03	104449-03	4
XP16-060	88W52	103366-03	4	43W22	100481-16	5	11X51	614045-03	104449-03	4
XP17-024	88W50	103366-01	1.5	33W84	100481-14	1.5	11X49	614045-01	104449-01	1.5
XP17-030	88W51	103366-02	3	33W84	100481-14	1.5	11X50	614045-02	104449-02	3

TABLE 1. Emerson to Parker to Emerson Chatleff Kit Outdoor TXV Cross Reference – Continued

Heat Pump Model #	Emerson TXV			Parker TXV			Emerson TXV (Chatleff-Style Kit)			
	Cat. #	Part #	Nominal Capacity	Cat. #	Part #	Nominal Capacity	Cat. #	Kit Part #	TXV Part # in kit	Nominal Capacity
XP17-036	88W51	103366-02	3	33W85	100481-15	3	11X50	614045-02	104449-02	3
XP17-042	88W52	103366-03	4	33W85	100481-15	3	11X51	614045-03	104449-03	4
XP17-048	88W52	103366-03	4	33W85	100481-15	3	11X51	614045-03	104449-03	4
XP17-060	88W52	103366-03	4	33W85	100481-15	3	11X51	614045-03	104449-03	4
XP21-024	88W50	103366-01	1.5	33W84	100481-14	1.5	11X49	614045-01	104449-01	1.5
XP21-036	88W51	103366-02	3	33W85	100481-15	3	11X50	614045-02	104449-02	3
XP21-048	88W52	103366-03	4	33W85	100481-15	3	11X51	614045-03	104449-03	4
XP21-060	88W52	103366-03	4	33W85	100481-15	3	11X51	614045-03	104449-03	4
XP25-024	88W50	103366-01	1.5	33W84	100481-14	1.5	11X49	614045-01	104449-01	1.5
XP25-036	10D57	103366-04	2	33W84	100481-14	1.5	11X49	614045-01	104449-01	1.5
XP25-048	88W52	103366-03	4	33W85	100481-15	3	11X50	614045-02	104449-02	3
XP25-060	88W52	103366-03	4	33W85	100481-15	3	11X51	614045-03	104449-03	4
4HP13*18	88W50	103366-01	1.5	33W84	100481-14	1.5	11X49	614045-01	104449-01	1.5
4HP13*24	88W50	103366-01	1.5	33W84	100481-14	1.5	11X49	614045-01	104449-01	1.5
4HP13*30	88W51	103366-02	3	33W84	100481-14	1.5	11X50	614045-02	104449-02	3
4HP13*36	88W51	103366-02	3	33W85	100481-15	3	11X50	614045-02	104449-02	3
4HP13*42	88W52	103366-03	4	33W85	100481-15	3	11X51	614045-03	104449-03	4
4HP13*48	88W52	103366-03	4	33W85	100481-15	3	11X51	614045-03	104449-03	4
4HP13*60	88W52	103366-03	4	33W85	100481-15	3	11X51	614045-03	104449-03	4
4HP14*18	88W50	103366-01	1.5	33W84	100481-14	1.5	11X49	614045-01	104449-01	1.5
4HP14*24	88W50	103366-01	1.5	33W84	100481-14	1.5	11X49	614045-01	104449-01	1.5
4HP14*30	88W51	103366-02	3	33W84	100481-14	1.5	11X50	614045-02	104449-02	3
4HP14*36	88W51	103366-02	3	33W85	100481-15	3	11X50	614045-02	104449-02	3
4HP14*42	88W52	103366-03	4	33W85	100481-15	3	11X51	614045-03	104449-03	4
4HP14*48	88W52	103366-03	4	33W85	100481-15	3	11X51	614045-03	104449-03	4
4HP14*60	88W52	103366-03	4	33W85	100481-15	3	11X51	614045-03	104449-03	4
4HP16**24	88W50	103366-01	1.5	33W84	100481-14	1.5	11X49	614045-01	104449-01	1.5
4HP16**36	88W51	103366-02	3	33W85	100481-15	3	11X50	614045-02	104449-02	3
4HP16**48	88W52	103366-03	4	33W85	100481-15	3	11X51	614045-03	104449-03	4
4HP16**60	88W52	103366-03	4	33W85	100481-15	3	11X51	614045-03	104449-03	4
4HP18**24	88W50	103366-01	1.5	33W84	100481-14	1.5	11X49	614045-01	104449-01	1.5
4HP18**36	88W51	103366-02	3	33W85	100481-15	3	11X50	614045-02	104449-02	3
4HP18**48	88W52	103366-03	4	33W85	100481-15	3	11X51	614045-03	104449-03	4
4HP18**60	88W52	103366-03	4	33W85	100481-15	3	11X51	614045-03	104449-03	4
4SHP13**18	88W50	103366-01	1.5	33W84	100481-14	1.5	11X49	614045-01	104449-01	1.5
4SHP13**24	88W50	103366-01	1.5	33W84	100481-14	1.5	11X49	614045-01	104449-01	1.5
4SHP13**30	88W51	103366-02	3	33W84	100481-14	1.5	11X50	614045-02	104449-02	3
4SHP13**36	88W51	103366-02	3	33W85	100481-15	3	11X50	614045-02	104449-02	3
4SHP13**42	88W52	103366-03	4	33W85	100481-15	3	11X51	614045-03	104449-03	4
4SHP13**48	88W52	103366-03	4	33W85	100481-15	3	11X51	614045-03	104449-03	4
4SHP13**60	88W52	103366-03	4	33W85	100481-15	3	11X51	614045-03	104449-03	4
4SHP14**18	88W50	103366-01	1.5	33W84	100481-14	1.5	11X49	614045-01	104449-01	1.5
4SHP14**24	88W50	103366-01	1.5	33W84	100481-14	1.5	11X49	614045-01	104449-01	1.5
4SHP14**30	88W51	103366-02	3	33W84	100481-14	1.5	11X50	614045-02	104449-02	3
4SHP14**36	88W51	103366-02	3	33W85	100481-15	3	11X50	614045-02	104449-02	3
4SHP14**42	88W52	103366-03	4	33W85	100481-15	3	11X51	614045-03	104449-03	4
4SHP14**48	88W52	103366-03	4	33W85	100481-15	3	11X51	614045-03	104449-03	4
4SHP14**60	88W52	103366-03	4	33W85	100481-15	3	11X51	614045-03	104449-03	4
4SHP16**24	88W50	103366-01	1.5	33W84	100481-14	1.5	11X49	614045-01	104449-01	1.5
4SHP16**36	88W51	103366-02	3	33W85	100481-15	3	11X50	614045-02	104449-02	3
4SHP16**48	88W52	103366-03	4	33W85	100481-15	3	11X51	614045-03	104449-03	4
4SHP16**60	88W52	103366-03	4	33W85	100481-15	3	11X51	614045-03	104449-03	4
4SHP18**24	88W50	103366-01	1.5	33W84	100481-14	1.5	11X49	614045-01	104449-01	1.5
4SHP18**36	88W51	103366-02	3	33W85	100481-15	3	11X50	614045-02	104449-02	3
4SHP18**48	88W52	103366-03	4	33W85	100481-15	3	11X51	614045-03	104449-03	4
4SHP18**60	88W52	103366-03	4	33W85	100481-15	3	11X51	614045-03	104449-03	4

NOTE - Parker TXV listing is the last Parker TXV used in production before changing to Emerson TXVs.

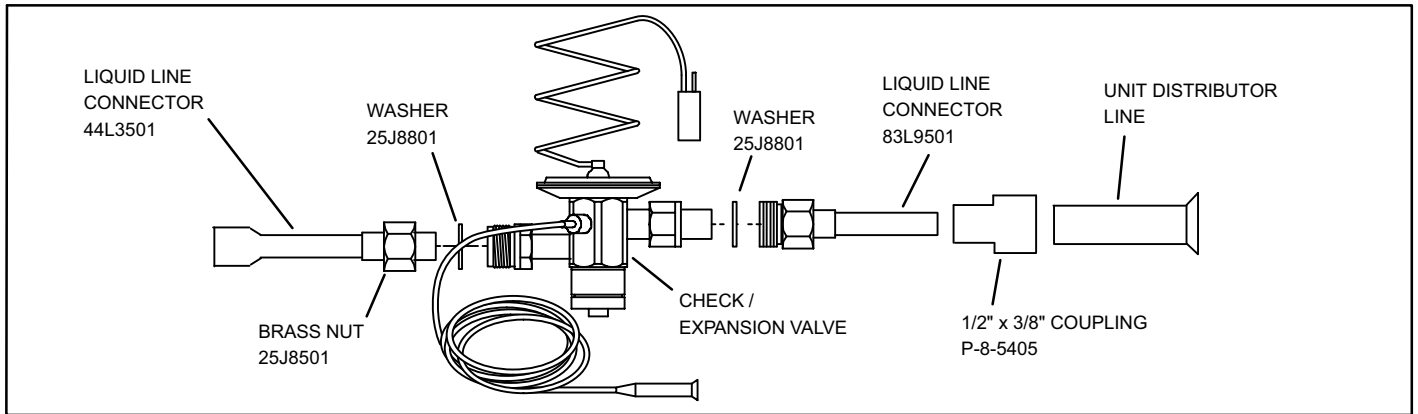

FIGURE 1. Chatleff-Style CTXV Assembly – Expanded View

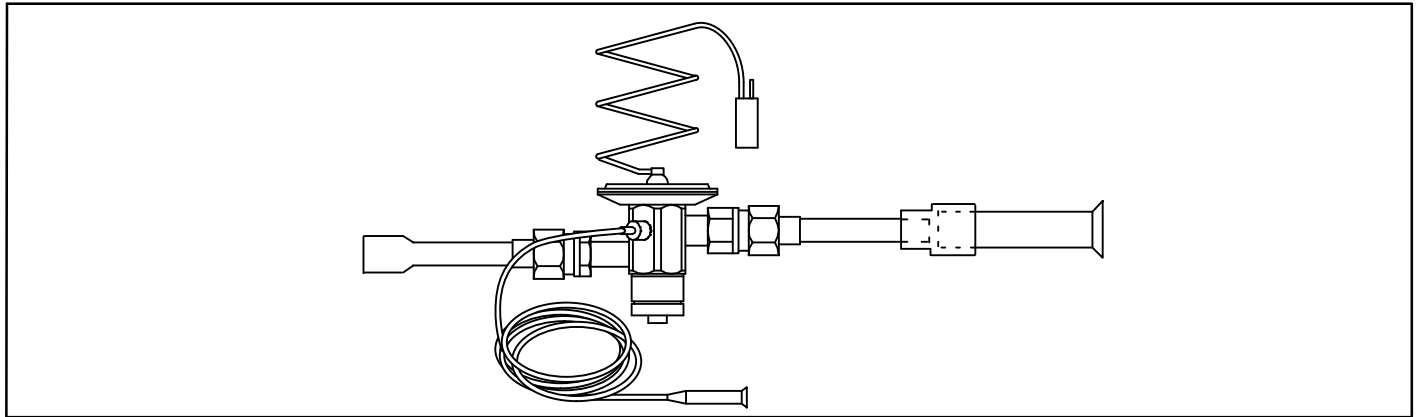

FIGURE 2. Chatleff-Style CTXV Assembly – Assembled

Typical CTXV Location

The following illustration is provided to assist the installer in locating the CTXV.

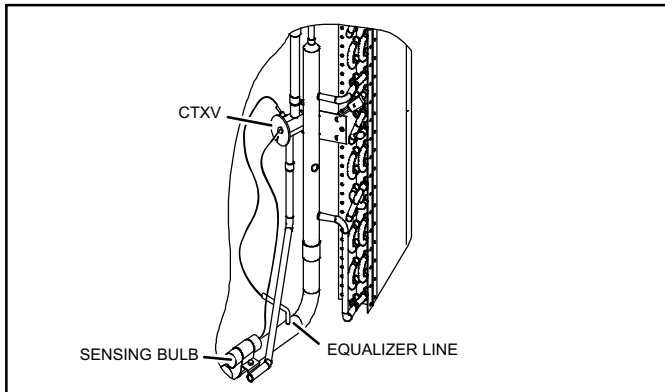

FIGURE 3. Typical Outdoor Unit CTXV Location

⚠ WARNING

Brazing alloys and flux contain materials, which are hazardous to health. Avoid breathing vapors or fumes from brazing operations. Perform operations only in well-ventilated areas. Wash hands with soap and water after handling brazing alloys and flux. Wear gloves and protective goggles or face shield to protect against burns.

⚠ WARNING

Danger of fire. Bleeding the refrigerant charge from only the high side may result in the low side shell and suction tubing being pressurized. Application of a brazing torch while pressurized may result in ignition of the refrigerant and oil mixture - check the high and low pressures before unbrazing.

Recovering Refrigerant from System

NOTE - Use recovery machine instructions for specific requirements.

1. Use the installation instructions that came with the outdoor unit for information on how to remove the outdoor unit's access panels and louvers.
2. Disconnect all power to the existing outdoor unit.
3. Connect a gauge set, clean recovery cylinder and a recovery machine to the outdoor unit. Use the instructions provided with the recovery machine to make the connections.
4. Remove all HFC-410A refrigerant from the existing system. Check gauges after shutdown to confirm that both sides of the system are completely void of refrigerant.

CTXV Replacement Procedure

The illustrations used in this example show typical component locations.

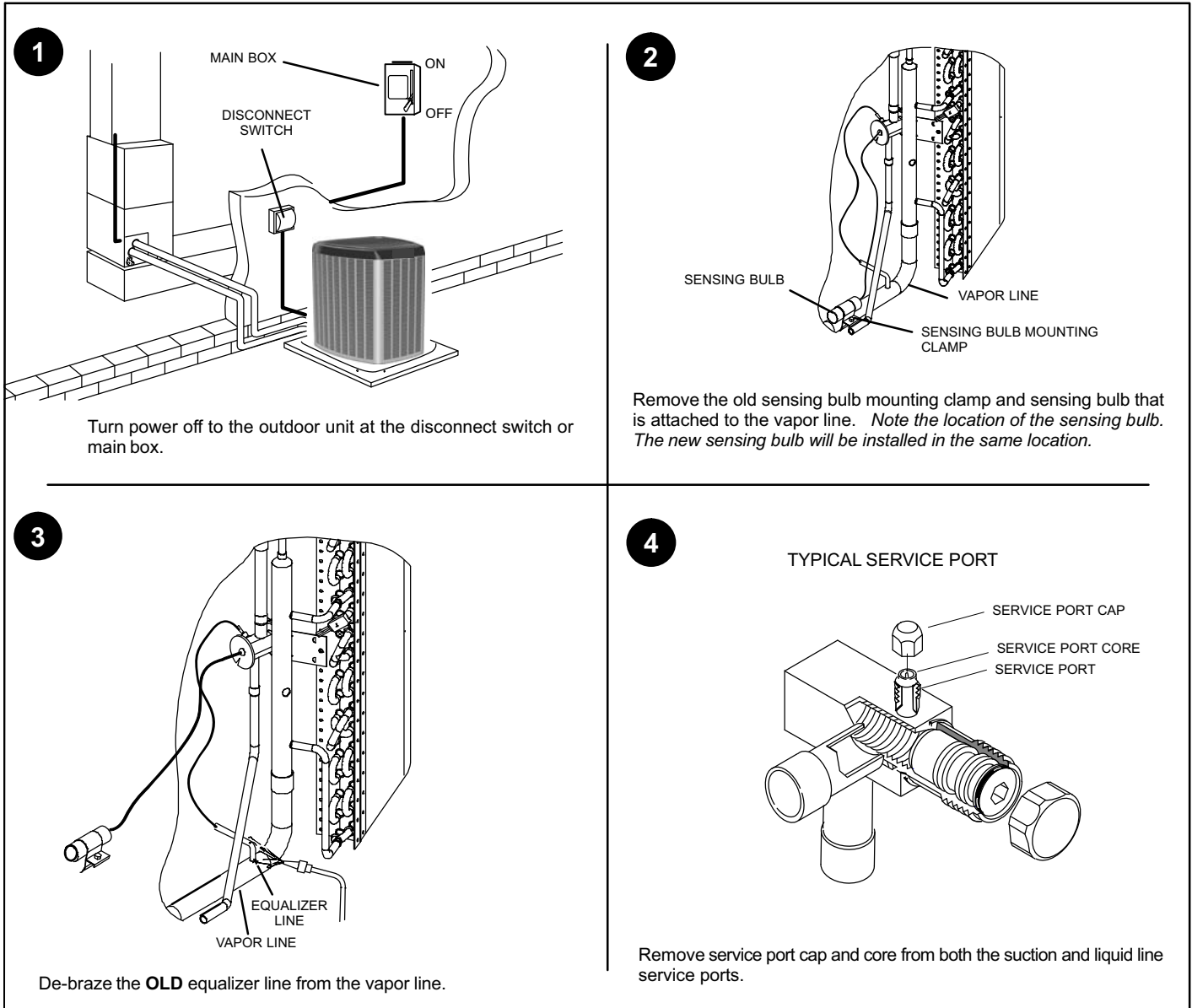

FIGURE 4. Check / Expansion Valve Replacement Procedure

⚠ WARNING

Polyol ester (POE) oils used with HFC-410A refrigerant absorb moisture very quickly. It is very important that the refrigerant system be kept closed as much as possible. **DO NOT** remove line set caps or service valve stub caps until you are ready to make connections.

⚠ WARNING



When brazing use an inert gas such as nitrogen to pressurize a heat pump or air conditioning system. Use a regulator that can control the pressure down to 1 or 2 psig (6.9 to 13.8 kPa).

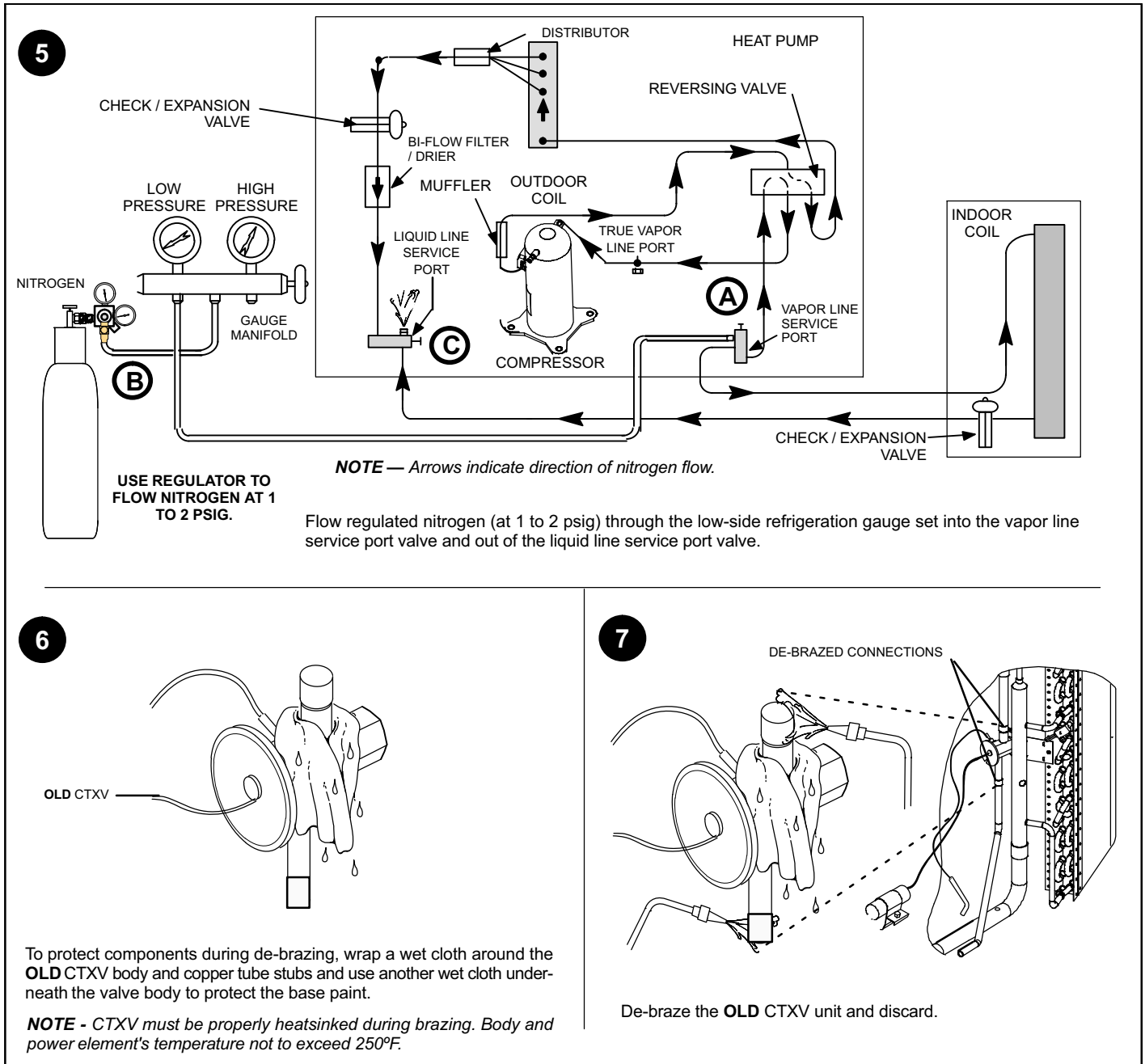
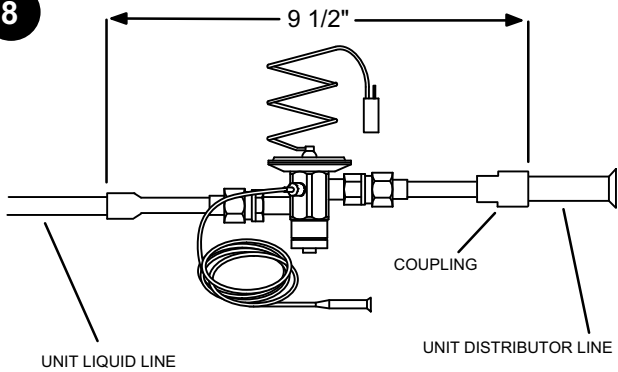

FIGURE 4. Check / Expansion Valve Replacement Procedure – Continued

8



When assembled, the kit parts are approximately 9 1/2" long. Measure the distance between the end of the unit distributor line and the end of the unit liquid line. If necessary, cut connectors to allow TXV assembly to fit.

9

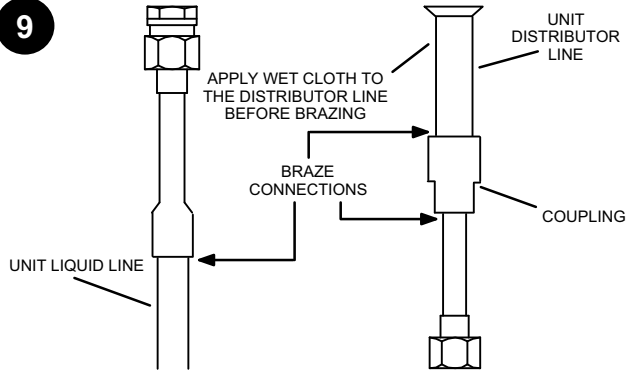

Remove the TXV and washers. Wrap the unit distributor line with a wet cloth to avoid damage to factory-brazed connections. Braze liquid line to connector and braze coupling to connector and distributor line. Allow connections to cool before removing wet cloth.

NOTE - Use silver alloy brazing rods with five percent minimum silver alloy for copper-to-copper brazing or 45 percent silver alloy for copper-to-brass or copper-to-steel brazing.

10

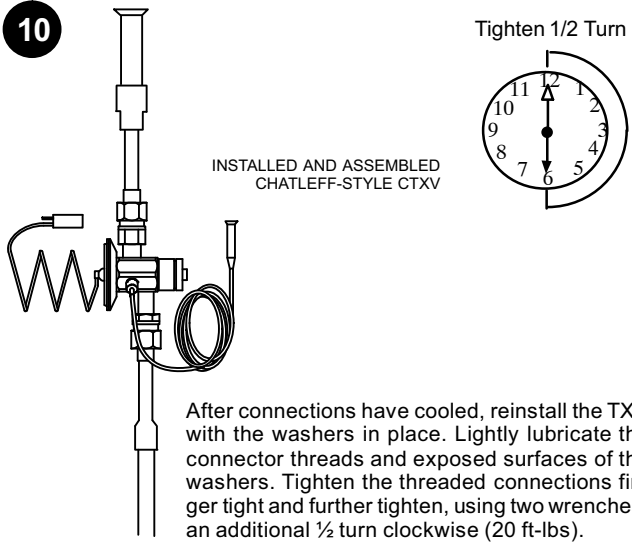

After connections have cooled, reinstall the TXV with the washers in place. Lightly lubricate the connector threads and exposed surfaces of the washers. Tighten the threaded connections finger tight and further tighten, using two wrenches, an additional 1/2 turn clockwise (20 ft-lbs).

11

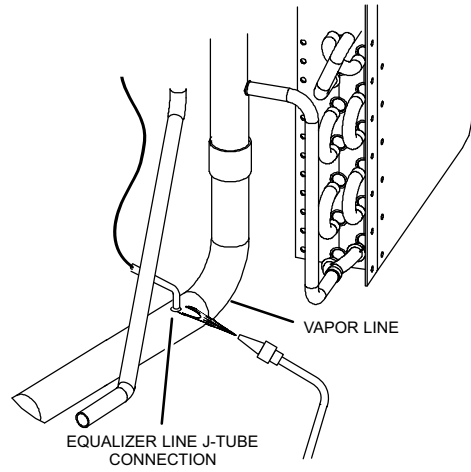

Braze the new equalizer J-tube insert to the vapor line.

12

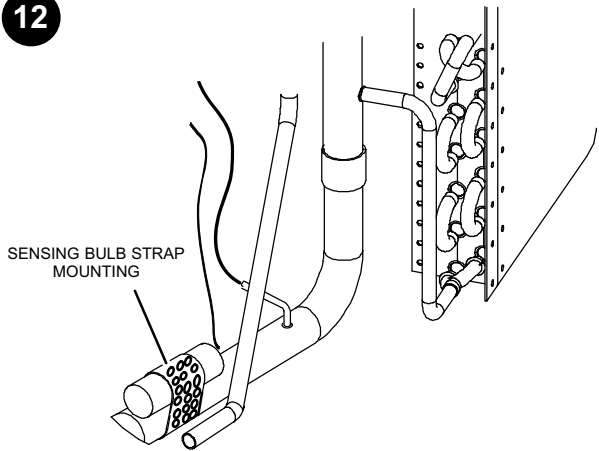

Install the **NEW** sensing bulb at the same location on the vapor line as the original one using the mounting hardware included in the kit.

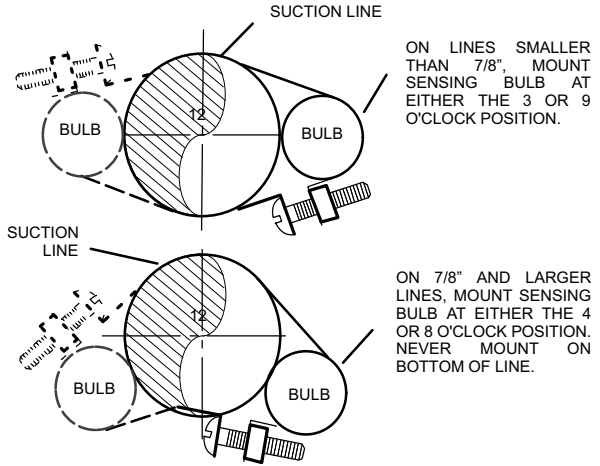

NOTE - NEVER MOUNT AT 6 O'CLOCK POSITION ON VAPOR LINE.

FIGURE 4. Check / Expansion Valve Replacement Procedure – Continued

Testing for Leaks

⚠ WARNING

Refrigerant can be harmful if it is inhaled. Refrigerant must be used and recovered responsibly.

Failure to follow this warning may result in personal injury or death.

⚠ IMPORTANT

Leak detector must be capable of sensing HFC refrigerant.

⚠ WARNING



Fire, Explosion and Personal Safety Hazard.

Failure to follow this warning could result in damage, personal injury or death.

Never use oxygen to pressurize or purge refrigeration lines. Oxygen, when exposed to a spark or open flame, can cause damage by fire and/or an explosion, that could result in personal injury or death.

Use the following procedure to test for leaks:

1. Connect an HFC-410A manifold gauge set high pressure hose to the suction valve service port. (Normally, the high pressure hose is connected to the liquid line port; however, connecting it to the suction port better protects the manifold gauge set from high pressure damage.)
2. With both manifold valves closed, connect the cylinder of HFC-410A refrigerant to the center port of the manifold gauge set. Open the valve on the HFC-410A cylinder (suction only).
3. Open the high pressure side of the manifold to allow HFC-410A into the line set and indoor unit. Weigh in a trace amount of HFC-410A. [A trace amount is a maximum of two ounces (57 g) refrigerant or three pounds (31 kPa) pressure]. Close the valve on the HFC-410A cylinder and the valve on the high pressure side of the manifold gauge set. Disconnect the HFC-410A cylinder.
4. Connect a cylinder of dry nitrogen with a pressure regulating valve to the center port of the manifold gauge set.
5. Adjust dry nitrogen pressure to 150 psig (1034 kPa). Open the valve on the high side of the manifold gauge set in order to pressurize the line set and the indoor unit.
6. After a few minutes, open one of the service valve ports and verify that the refrigerant added to the system earlier is measurable with a leak detector.
7. After leak testing, disconnect gauges from service ports.

Evacuating the System

Evacuating the system of non-condensables is critical for proper operation of the unit. Non-condensables are defined as any gas that will not condense under temperatures and pressures present during operation of an air conditioning system. Non-condensables and water combine with refrigerant to produce substances that corrode copper piping and compressor parts.

⚠ WARNING

Danger of Equipment Damage. Avoid deep vacuum operation. Do not use compressors to evacuate a system. Extremely low vacuums can cause internal arcing and compressor failure. Damage caused by deep vacuum operation will void warranty.

⚠ IMPORTANT

Use a thermocouple or thermistor electronic vacuum gauge that is calibrated in microns. Use an instrument capable of accurately measuring down to 50 microns.

1. Connect manifold gauge set to applicable port as illustrated in figure 5:
 - Low pressure gauge to *true suction* line (see figure 5 for location) .
 - High pressure gauge to *liquid* line service valve.

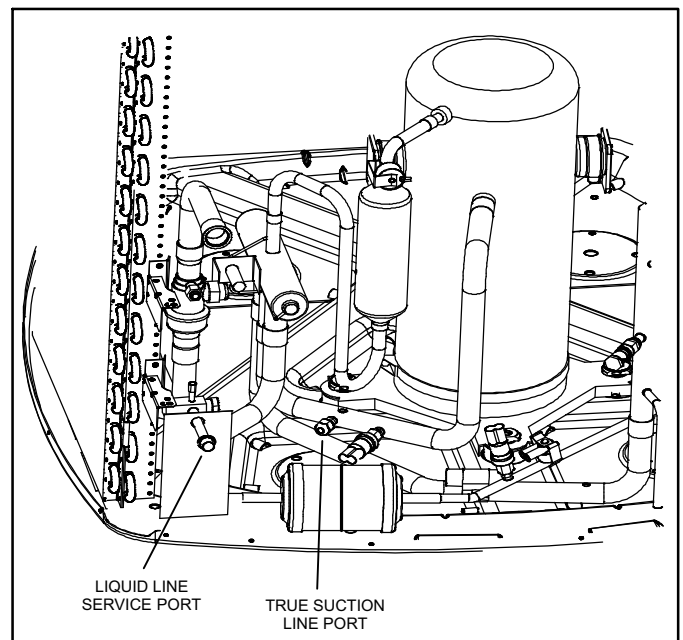

FIGURE 5. Typical Suction Line Port Location

2. Connect micron gauge.
3. Connect the vacuum pump (with vacuum gauge) to the center port of the manifold gauge set.
4. Open both manifold valves and start the vacuum pump.
5. Evacuate the line set and indoor unit to an **absolute pressure** of 23,000 microns (29.01 inches of mercury).

NOTE - During the early stages of evacuation, it is desirable to close the manifold gauge valve at least once. A rapid rise in pressure indicates a relatively large leak. If this occurs, **repeat the leak testing procedure**.

NOTE - The term **absolute pressure** means the total actual pressure within a given volume or system, above the absolute zero of pressure. Absolute pressure in a vacuum is equal to atmospheric pressure minus vacuum pressure.

6. When the absolute pressure reaches 23,000 microns (29.01 inches of mercury), close the manifold gauge valves, turn off the vacuum pump and disconnect the manifold gauge center port hose from vacuum pump. Attach the manifold center port hose to a dry nitrogen cylinder with pressure regulator set to 150 psig (1034 kPa) and purge the hose. Open the manifold gauge valves to break the vacuum in the line set and indoor unit. Close the manifold gauge valves.
7. Shut off the dry nitrogen cylinder and remove the manifold gauge hose from the cylinder. Open the manifold gauge valves to release the dry nitrogen from the line set and indoor unit.
8. Reconnect the manifold gauge to the vacuum pump, turn the pump on, and continue to evacuate the line set and indoor unit until the absolute pressure does not rise above 500 microns (29.9 inches of mercury) within

a 20-minute period after shutting off the vacuum pump and closing the manifold gauge valves.

9. When the absolute pressure requirement above has been met, disconnect the manifold hose from the vacuum pump and connect it to an upright cylinder of HFC-410A refrigerant.

Start-Up Procedure

1. Rotate fan to check for binding.
2. Inspect all factory- and field-installed wiring for loose connections.
3. Check voltage supply at the disconnect switch. The voltage must be within the range listed on the unit's nameplate. If not, do not start the equipment until you have consulted with the power company and the voltage condition has been corrected.
4. Set the thermostat for a cooling demand. Turn on power to the indoor indoor unit and close the outdoor unit disconnect switch to start the unit.
5. Recheck voltage while the unit is running. Power must be within range shown on the nameplate.
6. Charge should be checked and adjusted using the tables provided on the charging procedure sticker on the unit access panel.
Detailed information is given in the unit Installation and Service Procedures manual, available on DaveNet.