



©2012 Lennox Industries Inc.
Dallas, Texas, USA



icomfort.
So simple. So smart. So comfortable.



**RETAIN THESE INSTRUCTIONS
FOR FUTURE REFERENCE**

General

This XP21 outdoor heat pump is designed for use with HFC-410A refrigerant only. This unit must be installed with an approved indoor air handler or coil. See the Lennox XP21 Product Specifications bulletin (EHB) for approved indoor component match ups.

These instructions are intended as a general guide and do not supersede local codes in any way. Consult authorities having jurisdiction before installation.

NOTICE !

For more in-depth information, consult the **Installation and Service Procedures manual**, available as Corp.1031-L7 on DaveNet or through the Technical Support department at 800-453-6669.

INSTALLATION INSTRUCTIONS

Dave Lennox *Signature*[®] Collection XP21 System

HEAT PUMPS
506839-01
2/2012
Supersedes 12/2011

TP Technical
Publications
Litho U.S.A.

⚠ WARNING

Improper installation, adjustment, alteration, service or maintenance can cause property damage, personal injury or loss of life.

Installation and service must be performed by a licensed professional installer (or equivalent) or service agency.

⚠ CAUTION

Before attempting to perform any service or maintenance, turn the electrical power to unit OFF at disconnect switch.

⚠ CAUTION

As with any mechanical equipment, contact with sharp sheet metal edges can result in personal injury. Take care while handling this equipment.

STEP 1 -- SETTING THE UNIT -- Clearances

CLEARANCE ON ALL SIDES — INCHES (MILLIMETERS)

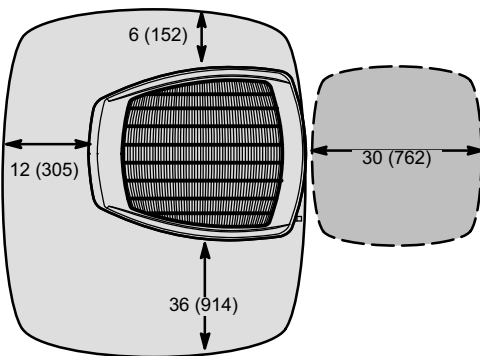

NOTES:

- Clearance to access panel must be 30 inches (762mm).
- Clearance to one of the other three sides must be 36 inches (914mm).
- Clearance to one of the remaining two sides may be 12 inches (305mm) and the final side may be 6 inches (152mm).

MINIMUM CLEARANCE ABOVE UNIT

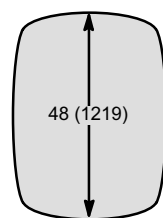

MINIMUM CLEARANCE BETWEEN TWO UNITS

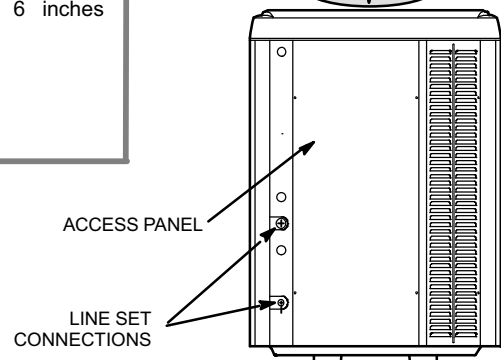
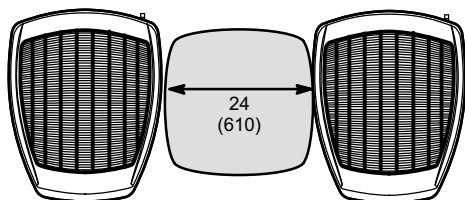

REAR VIEW OF UNIT

Figure 1



UNIT DIMENSIONS - INCHES (MM)

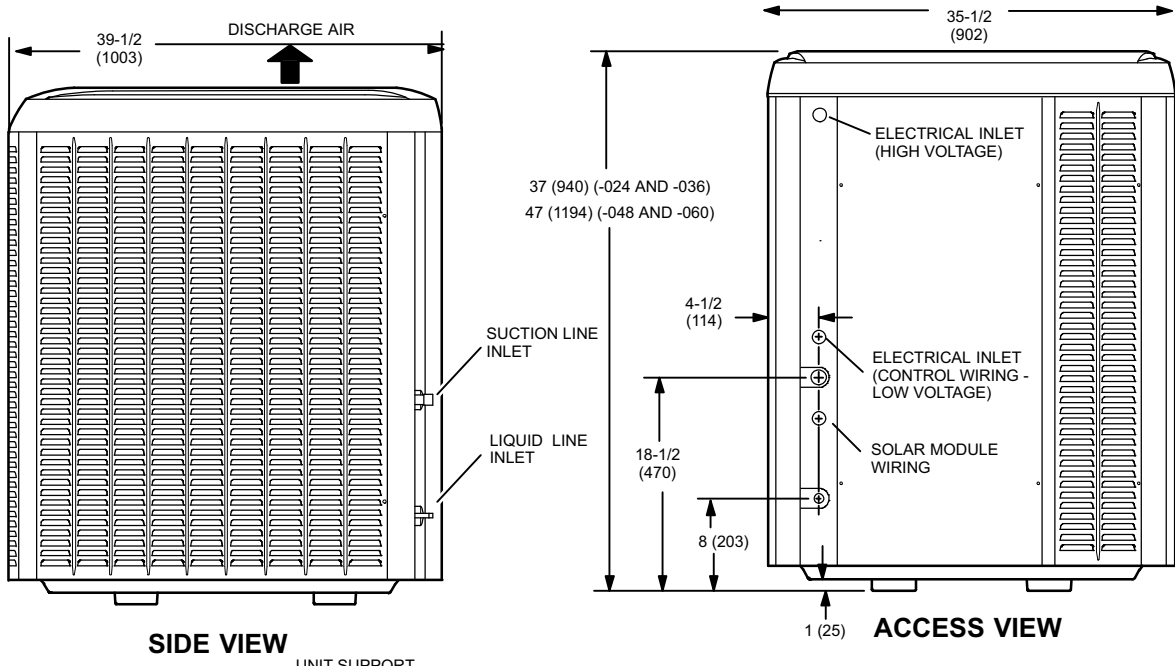

SIDE VIEW

ACCESS VIEW

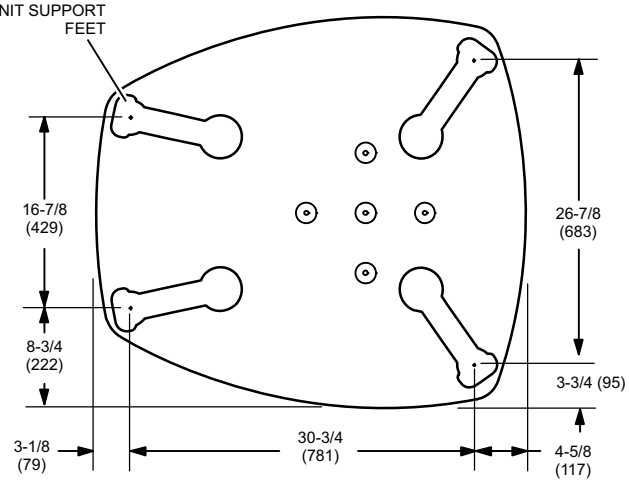

BASE WITH ELONGATED LEGS

STEP 1 -- SETTING THE UNIT (Continued) -- Unit Placement

⚠ WARNING

To prevent personal injury, as well as damage to panels, unit or structure, observe the following:

While installing or servicing this unit, carefully stow all removed panels so that the panels will not cause injury to personnel, objects or nearby structures. Also, take care to store panels where they will not be subject to damage (e.g., being bent or scratched).

While handling or stowing the panels, consider any weather conditions (especially wind) that may cause panels to be blown around and damaged.

NOTICE !

Roof Damage!

This system contains both refrigerant and oil. Some rubber roofing material may absorb oil, causing the rubber to degrade. Failure to follow this notice could result in damage to roof surface.

IMPORTANT !

Exhaust vents from dryers, water heaters and furnaces should be directed away from the outdoor unit. Prolonged exposure to exhaust gases and the chemicals contained within them may cause condensation to form on the steel cabinet and other metal components of the outdoor unit. This will diminish unit performance and longevity.

PLACEMENT

INSTALL UNIT AWAY FROM WINDOWS

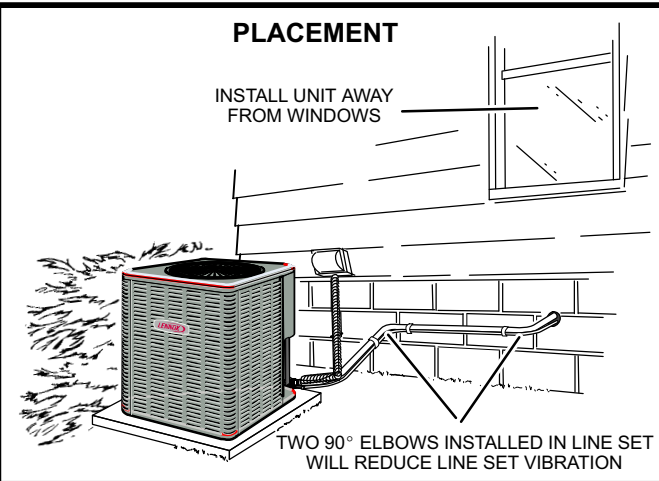

Figure 2

SLAB MOUNTING

Install unit level or, if on a slope, maintain slope tolerance of 2 degrees (or 2 inches per 5 feet [50 mm per 1.5 m]) away from building structure

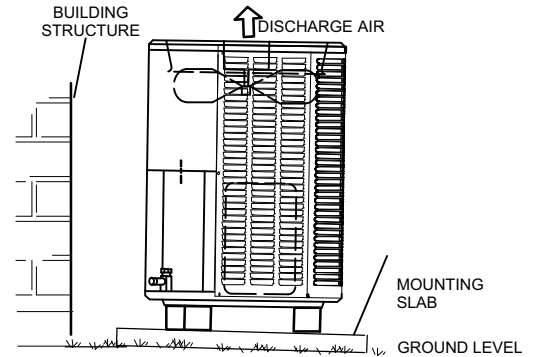

Figure 3

ELEVATED SLAB MOUNTING USING FEET EXTENDERS

Use additional 2" SCH 40 male threaded adapters which can be threaded into the female threaded adapters to make additional adjustments to the level of the unit.

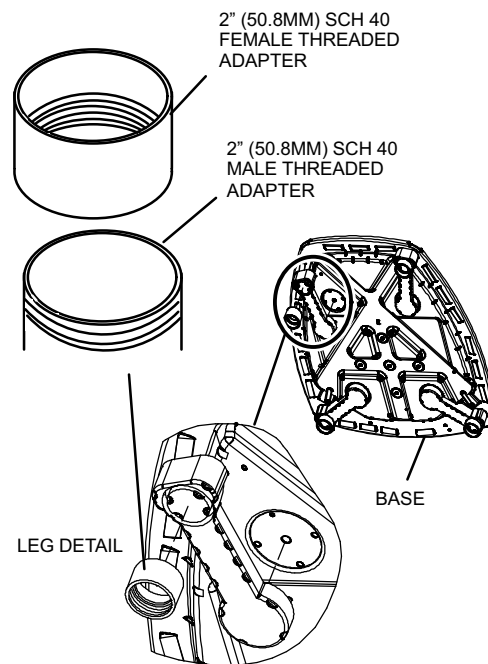

Figure 4

IMPORTANT !

This model is designed for use in check / expansion valve systems only. An indoor expansion valve approved for use with HFC-410A refrigerant must be ordered separately and installed prior to operating the system.

STEP 1 -- SETTING THE UNIT (Continued) -- Unit Placement

STABILIZING UNIT ON UNEVEN SURFACES

DETAIL D — Slab Mounting

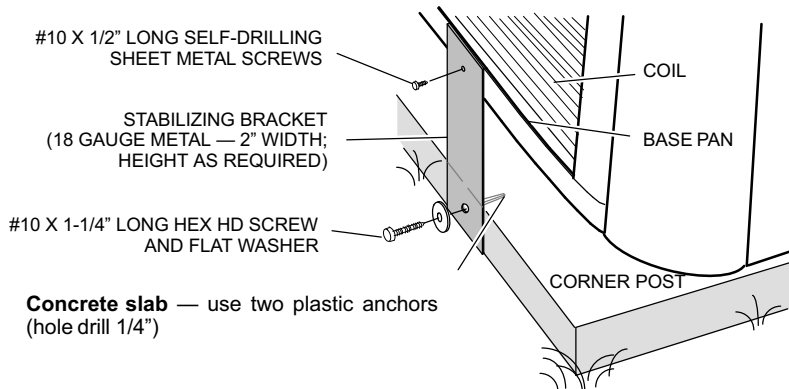

IMPORTANT !

Unit Stabilizer Bracket Use (field-provided):
Always use stabilizers when unit is raised above the factory height. (Elevated units could become unstable in gusty wind conditions.)
Stabilizers may be used on any unit installed on unstable and uneven surfaces.

DETAIL E — Deck Top Mounting

Stabilizing bracket (18 gauge metal — 2" [50.8mm] width; height as required); bend to form right angle as shown below.

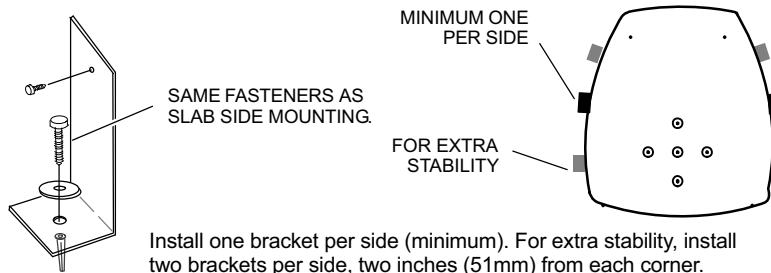

DETAIL F — Wind Barrier

Install the unit a minimum of six inches (152 mm) above the roof surface to avoid ice build-up around the unit. Locate the unit above a load-bearing wall or area of the roof that can adequately support the unit. Consult local codes for rooftop applications.

If coil must be installed facing prevailing winter winds, a wind barrier should be constructed. Size barrier at least the same height and width as outdoor unit. Install barrier 24 inches (610 mm) from the sides of the unit in the direction of prevailing winds.

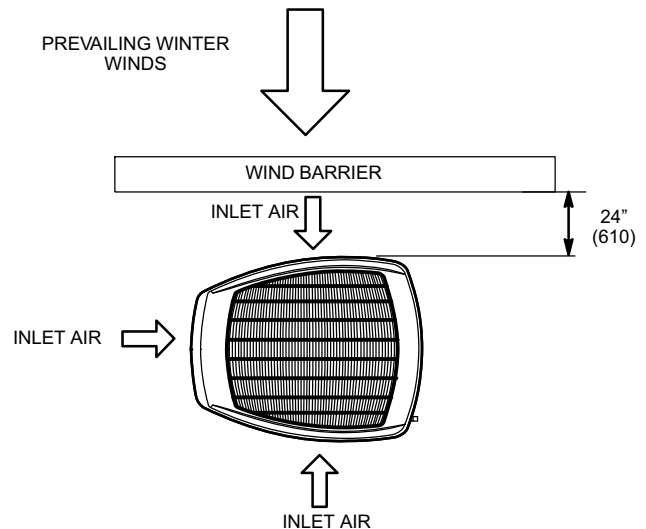

Figure 5

STEP 2 -- REFRIGERANT PIPING -- Flushing Existing Line Set & Indoor Coil

Flush the existing line set per the following instructions. For more information, refer to the Installation and Service Procedures manual available on DaveNet. **CAUTION -DO NOT** attempt to flush and re-use existing line sets or indoor coil when the system contains contaminants (i.e., compressor burn out).

NOTE - When installing refrigerant lines longer than 50 feet, refer to the Refrigerant Piping Design and Fabrication Guidelines manual available on DaveNet (Corp. 9351-L9), or contact the Technical Support Department Product Application group for assistance.

NOTE - For new or replacement line set installation refer to Service and Application Note - Corp 9112-L4 (C-91-4).

Table 1. Refrigerant Line Set — Inches (mm)

Models	Liquid Line	Vapor/ Suction Line	L15 Line Set
-024, -036 and-048	3/8 (10)	7/8 (22)	L15 line set sizes are dependent on unit match up. See XP21 Engineering Handbook to determine correct line set sizes.
-060	3/8 (10)	1-1/8" (29)	Field Fabricated
NOTE — Some applications may required a field-provided 7/8" to 1-1/8" adapter.			

IMPORTANT !

If this unit is being matched with an approved line set or indoor unit coil that was previously charged with mineral oil, or if it is being matched with a coil which was manufactured before January of 1999, the coil and line set must be flushed prior to installation. Take care to empty all existing traps. Polyol ester (POE) oils are used in Lennox units charged with HFC-410A refrigerant. Residual mineral oil can act as an insulator, preventing proper heat transfer. It can also clog the expansion device and reduce system performance and capacity.

Failure to properly flush the system per this instruction and the detailed Installation and Service Procedures manual will void the warranty.

⚠ WARNING



When using a high pressure gas such as nitrogen to pressurize a refrigeration or air conditioning system, use a regulator that can control the pressure down to 1 or 2 psig (6.9 to 13.8 kPa).

⚠ WARNING

Refrigerant can be harmful if it is inhaled. Refrigerant must be used and recovered responsibly. Failure to follow this warning may result in personal injury or death.

⚠ WARNING



Fire, Explosion and Personal Safety Hazard. Failure to follow this warning could result in damage, personal injury or death. Never use oxygen to pressurize or purge refrigeration lines. Oxygen, when exposed to a spark or open flame, can cause fire and/or an explosion, that could result in property damage, personal injury or death.

⚠ WARNING

Polyol ester (POE) oils used with HFC-410A refrigerant absorb moisture very quickly. It is very important that the refrigerant system be kept closed as much as possible. DO NOT remove line set caps or service valve stub caps until you are ready to make connections.

IMPORTANT !

Some scroll compressors have an internal vacuum protection devices that will unload scrolls when suction pressure goes below 20 psig. A hissing sound will be heard when the compressor is running unloaded. The protection device will reset when pressure in system rises above 40 psig. This is normal operation. DO NOT replace compressor.

STEP 2 -- REFRIGERANT PIPING -- Removing Existing Indoor Metering Device

1A TYPICAL EXISTING FIXED ORIFICE REMOVAL PROCEDURE (UNCASED COIL SHOWN)

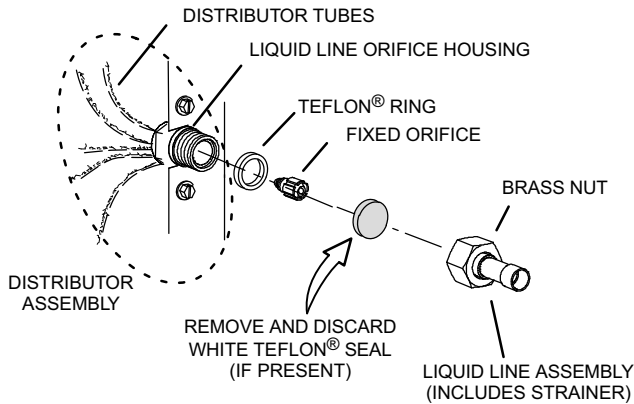

- On fully cased coils, remove the coil access and plumbing panels.
- Remove any shipping clamps from the liquid line and distributor assembly.
- Using two wrenches, disconnect liquid line from liquid line orifice housing. Take care not to twist or damage distributor tubes during this process.
- Remove and discard fixed orifice, valve stem assembly (if present) and Teflon® washer as illustrated above.
- Use a field-provided fitting to temporarily reconnect the liquid line to the indoor unit's liquid line orifice housing.

OR 1B TYPICAL EXISTING EXPANSION VALVE REMOVAL PROCEDURE (UNCASED COIL SHOWN)

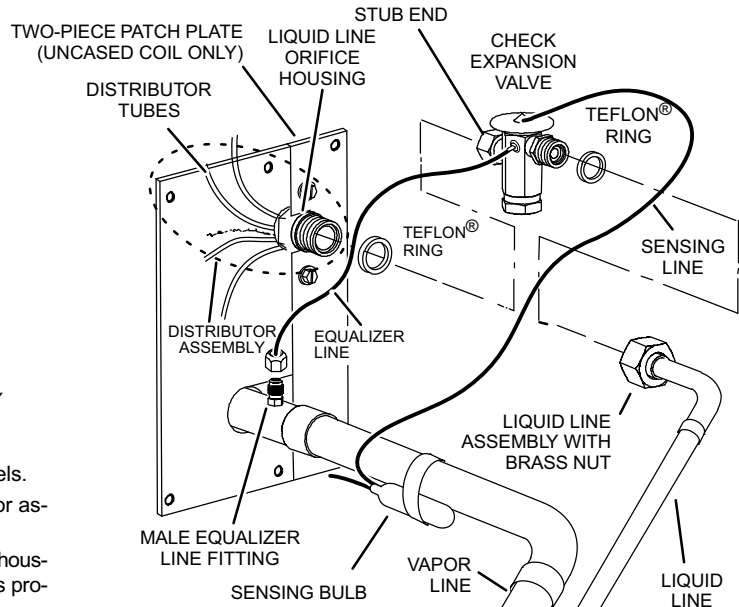

- On fully cased coils, remove the coil access and plumbing panels.
- Remove any shipping clamps from the liquid line and distributor assembly.
- Disconnect the equalizer line from the check expansion valve equalizer line fitting on the vapor line.
- Remove the vapor line sensing bulb.
- Disconnect the liquid line from the check expansion valve at the liquid line assembly.
- Disconnect the check expansion valve from the liquid line orifice housing. Take care not to twist or damage distributor tubes during this process.
- Remove and discard check expansion valve and the two Teflon® rings.
- Use a field-provided fitting to temporarily reconnect the liquid line to the indoor unit's liquid line orifice housing.

2 CONNECT GAUGES AND EQUIPMENT FOR FLUSHING PROCEDURE

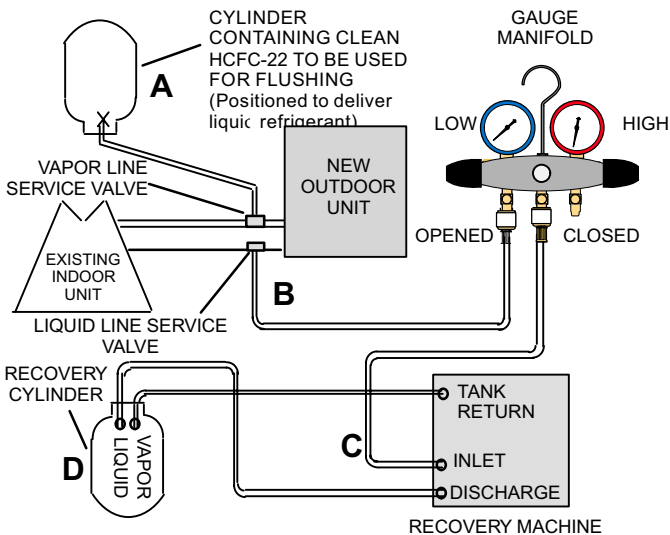

- HCFC-22 cylinder with clean refrigerant (positioned to deliver liquid refrigerant) to the vapor service valve.
- HCFC-22 gauge set (low side) to the liquid line valve.
- HCFC-22 gauge set center port to inlet on the recovery machine with an empty recovery tank connected to the gauge set.
- Connect recovery tank to recovery machine per machine instructions.

3 FLUSHING LINE SET

The line set and indoor unit coil must be flushed with at least the same amount of clean refrigerant that previously charged the system. Check the charge in the flushing cylinder before proceeding.

- Set the recovery machine for liquid recovery and start the recovery machine. Open the gauge set valves to allow the recovery machine to pull a vacuum on the existing system line set and indoor unit coil.
- Position the cylinder of clean HCFC-22 for delivery of liquid refrigerant and open its valve to allow liquid refrigerant to flow into the system through the vapor line valve. Allow the refrigerant to pass from the cylinder and through the line set and the indoor unit coil before it enters the recovery machine.
- After all of the liquid refrigerant has been recovered, switch the recovery machine to vapor recovery so that all of the HCFC-22 vapor is recovered. Allow the recovery machine to pull the system down to 0.
- Close the valve on the inverted HCFC-22 drum and the gauge set valves. Pump the remaining refrigerant out of the recovery machine and turn the machine off.

Figure 6

STEP 2 -- REFRIGERANT PIPING -- Brazing Procedures

1 PIPING PANEL REMOVAL / PREPARING LINE SET

Remove piping panel to access service valves. Cut ends of the refrigerant lines square (free from nicks or dents) and debur the ends. The pipe must remain round. Do not crimp end of the line.

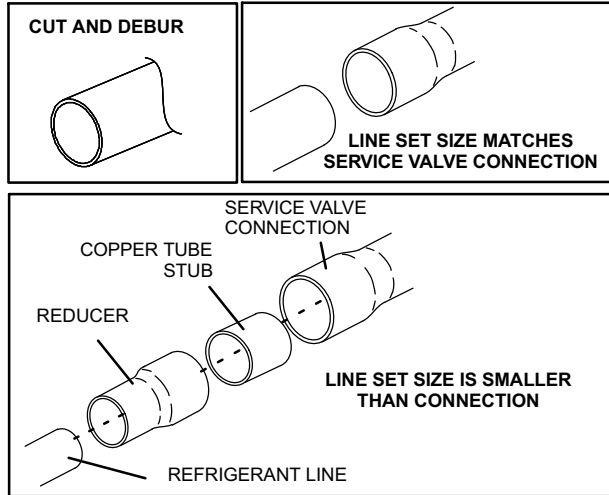

DO NOT CRIMP SERVICE VALVE CONNECTOR WHEN PIPE IS SMALLER THAN CONNECTION

2 CAP AND CORE REMOVAL

Remove service cap and core from both the suction / vapor and liquid line service ports.

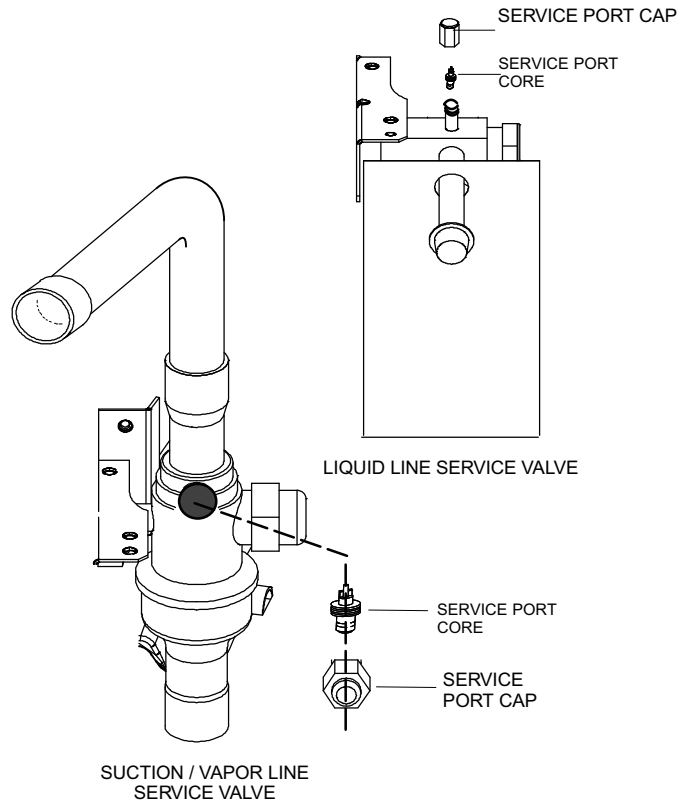

3 ATTACH THE MANIFOLD GAUGE SET FOR BRAZING LIQUID AND SUCTION / VAPOR LINE SERVICE VALVES

- A. Connect gauge set low pressure side to liquid line service valve (service port).
- B. Connect gauge set center port to bottle of nitrogen with regulator.
- C. With valve core removed from the suction / vapor line service port, nitrogen flow will have an exit point.

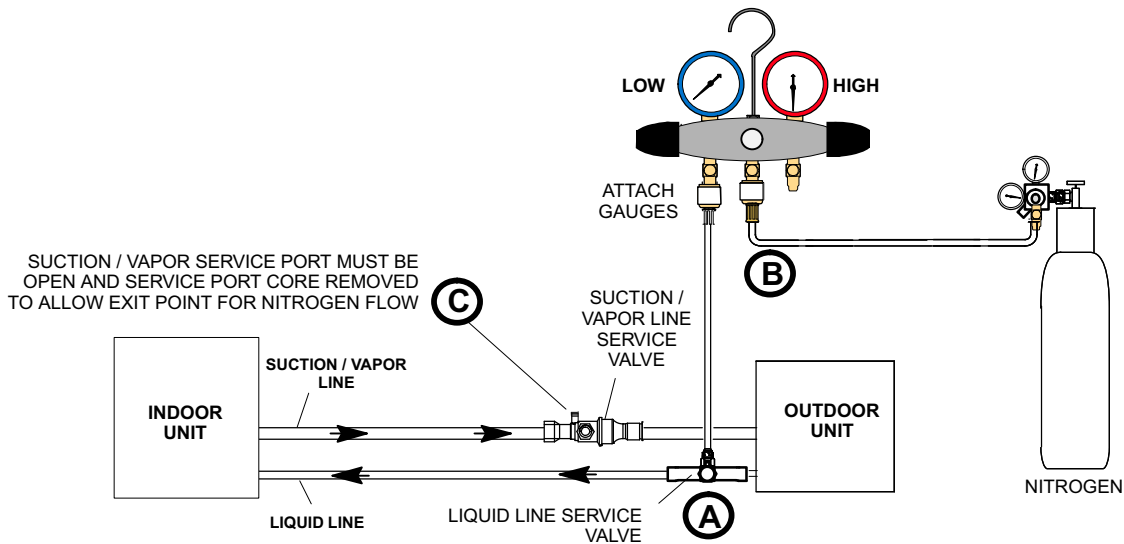

Figure 7

⚠ CAUTION

Brazing alloys and flux contain materials which are hazardous to your health.

Avoid breathing vapors or fumes from brazing operations. Perform operations only in well-ventilated areas.

Wear gloves and protective goggles or face shield to protect against burns.

Wash hands with soap and water after handling brazing alloys and flux.

⚠ WARNING



Danger of fire. Bleeding the refrigerant charge from only the high side may result in pressurization of the low side shell and suction tubing. Application of a brazing torch to a pressurized system may result in ignition of the refrigerant and oil mixture. Check the high and low pressures before applying heat.

4 WRAP SERVICE VALVES

To help protect service valve seals during brazing, wrap water-saturated cloths around service valve bodies and copper tube stubs. Use additional water-saturated cloths under the valve body to protect the base paint.

5 FLOW NITROGEN

Flow regulated nitrogen (at 1 to 2 psig) through the refrigeration gauge set into the valve stem port connection on the liquid service valve and out of the suction / vapor valve stem port. See steps 3A, 3B and 3C on previous page and below for manifold gauge setup.

6 BRAZE LINE SET

Cloths must remain water-saturated throughout the brazing and cool-down process.

- A. Braze liquid line to liquid line service valve.
- B. Braze suction / vapor line to suction / vapor service valve.



WARNING

FIRE, PERSONAL INJURY, OR PROPERTY DAMAGE may result if you do not wrap a water-saturated cloth around both liquid and suction line service valve bodies and copper tube stub while brazing the line set! The braze, when complete, must be quenched with water to absorb any residual heat.

Do not open service valves until refrigerant lines and indoor coil have been leak-tested and evacuated. Refer to Installation and Service Procedures manual found on DAVENET.

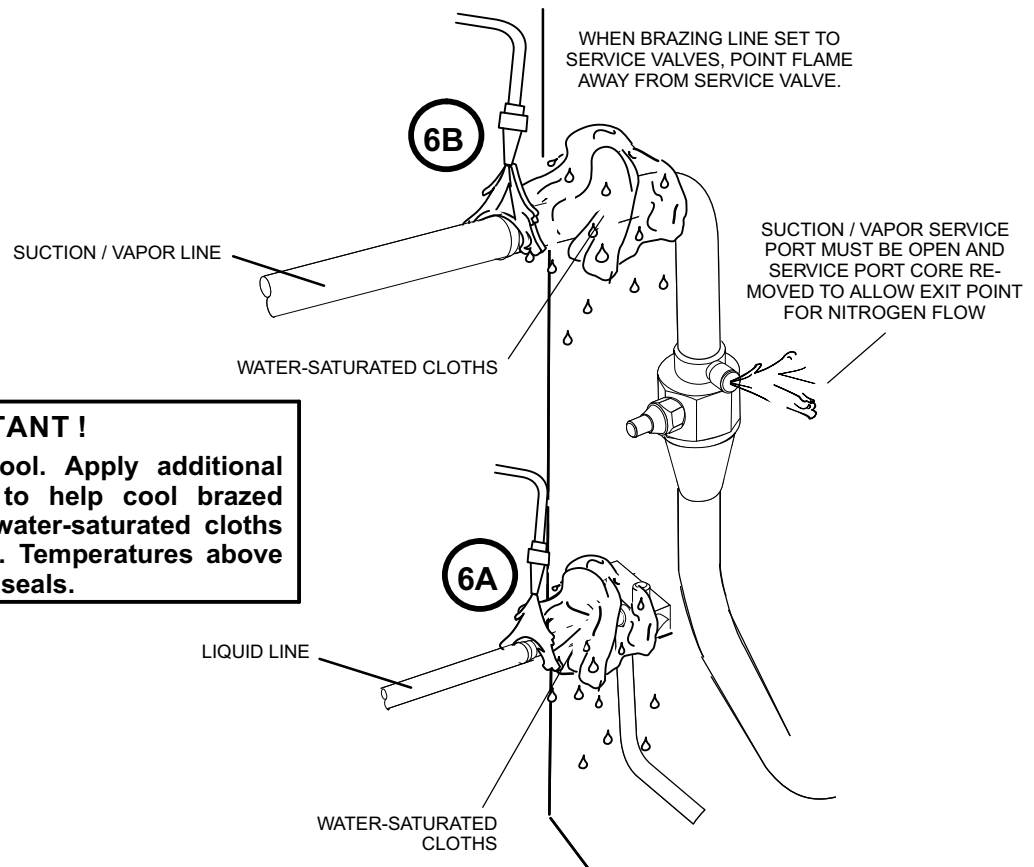

IMPORTANT!

Allow braze joint to cool. Apply additional water-saturated cloths to help cool brazed joints. Do not remove water-saturated cloths until piping has cooled. Temperatures above 250°F will damage valve seals.

7 PREPARATION FOR NEXT STEP

After all connections have been brazed, disconnect manifold gauge set from service ports. Apply additional water-saturated cloths to both services valves to cool piping. Once piping is cool, remove all water-saturated cloths.

Figure 8

STEP 3 -- INSTALLING INDOOR EXPANSION VALVE

This outdoor unit is designed for use in systems that use a check/expansion valve metering device. See the *XP21 Product Specifications bulletin* for approved check/expansion valve kit match-ups and application information. The check/expansion valve can be installed internal or external to the indoor coil. In applications where an uncased coil is being installed in a field-provided plenum, install the check/expansion valve in a manner that will provide access for future field service of the check expansion valve. Refer to below illustration for reference during installation of check/expansion valve.

INDOOR EXPANSION VALVE INSTALLATION

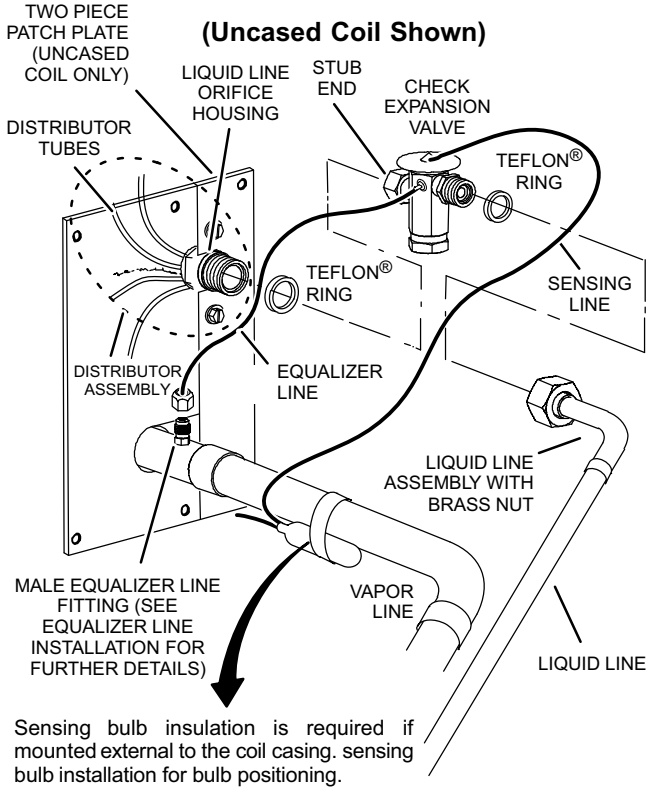

EQUALIZER LINE INSTALLATION

- Remove and discard either the flare seal cap or flare nut with copper flare seal bonnet from the equalizer line port on the vapor line as illustrated in the figure below.
- Remove the field-provided fitting that temporary reconnected the liquid line to the indoor unit's distributor assembly.

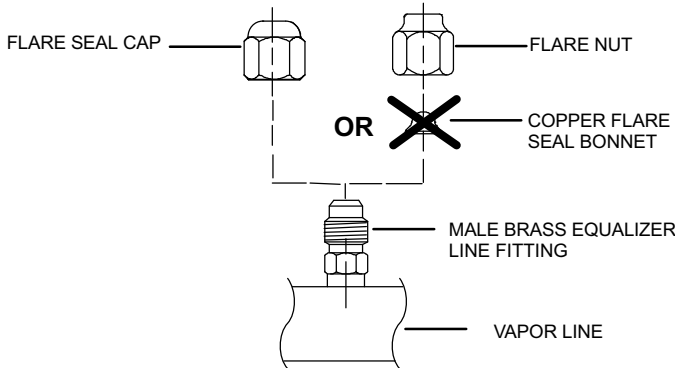

- Install one of the provided Teflon® rings around the stubbed end of the check expansion valve and lightly lubricate the connector threads and expose surface of the Teflon® ring with refrigerant oil.
- Attach the stubbed end of the check expansion valve to the liquid line orifice housing. Finger tighten and use an appropriately sized wrench to turn an additional 1/2 turn clockwise as illustrated in the figure above, or 20 ft-lb.
- Place the remaining Teflon® washer around the other end of the check expansion valve. Lightly lubricate connector threads and expose surface of the Teflon® ring with refrigerant oil.
- Attach the liquid line assembly to the check expansion valve. Finger tighten and use an appropriately sized wrench to turn an additional 1/2 turn clockwise as illustrated in the figure above or 20 ft-lb.

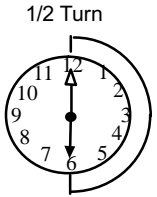

SENSING BULB INSTALLATION

- Attach the vapor line sensing bulb in the proper orientation as illustrated to the right using the clamp and screws provided.
- NOTE** — Confirm proper thermal contact between vapor line and check expansion bulb before insulating the sensing bulb once installed.
- Connect the equalizer line from the check expansion valve to the equalizer vapor port on the vapor line. Finger tighten the flare nut plus 1/8 turn (7 ft-lbs) as illustrated below.

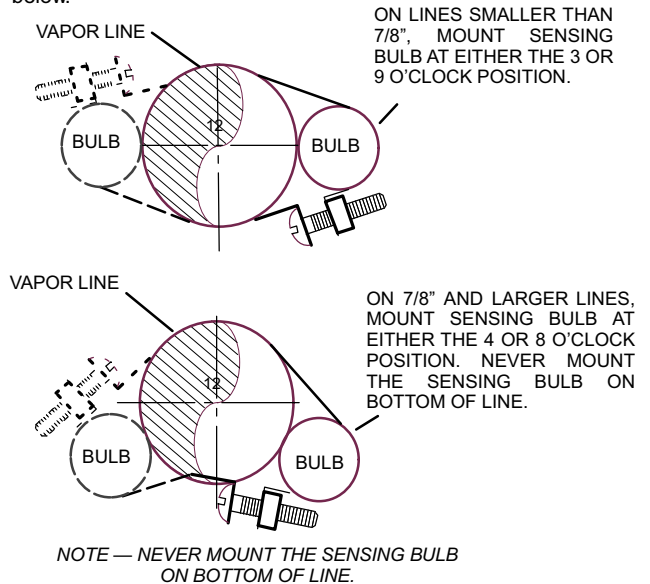
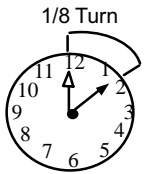
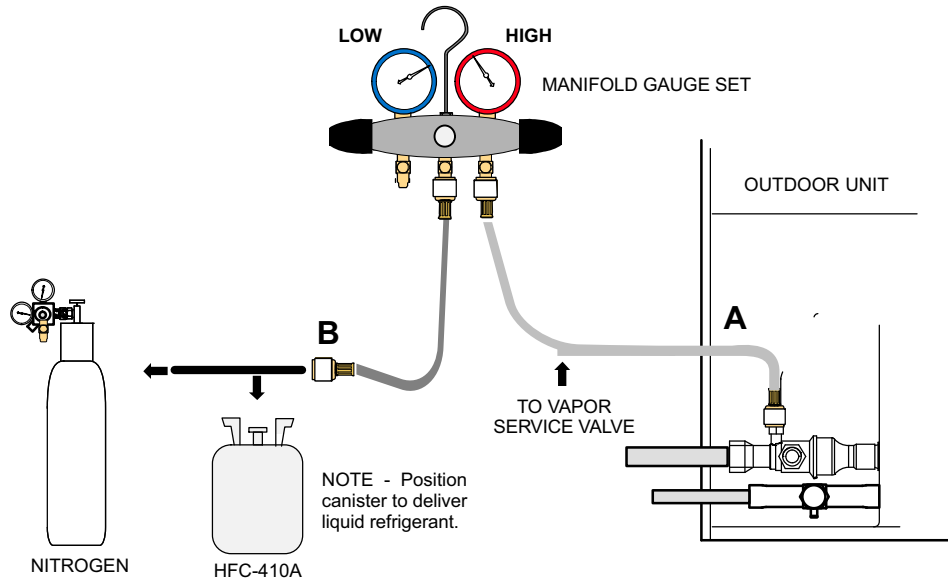

Figure 5

STEP 4 -- LEAK TEST AND EVACUATION



1 CONNECT GAUGE SET

- A. Connect the high pressure hose of an HFC-410A manifold gauge set to the vapor valve service port.

NOTE — Normally, the high pressure hose is connected to the liquid line port. However, connecting it to the vapor port better protects the manifold gauge set from high pressure damage.

- B. With both manifold valves closed, connect the cylinder of HFC-410A refrigerant to the center port of the manifold gauge set.

NOTE — Later in the procedure, the HFC-410A container will be replaced by the nitrogen container.

2 TEST FOR LEAKS

After the line set has been connected to the indoor and outdoor units, check the line set connections and indoor unit for leaks. Use the following procedure to test for leaks:

- A. With both manifold valves closed, connect the cylinder of HFC-410A refrigerant to the center port of the manifold gauge set. Open the valve on the HFC-410A cylinder (vapor only).
- B. Open the high pressure side of the manifold to allow HFC-410A into the line set and indoor unit. Weigh in a trace amount of HFC-410A. [A trace amount is a maximum of two ounces (57 g) refrigerant or three pounds (31 kPa) pressure.] Close the valve on the HFC-410A cylinder and the valve on the high pressure side of the manifold gauge set. Disconnect the HFC-410A cylinder.
- C. Connect a cylinder of nitrogen with a pressure regulating valve to the center port of the manifold gauge set.
- D. Adjust nitrogen pressure to 150 psig (1034 kPa). Open the valve on the high side of the manifold gauge set in order to pressurize the line set and the indoor unit.
- E. After a few minutes, open one of the service valve ports and verify that the refrigerant added to the system earlier is measurable with a leak detector.
- F. After leak testing, disconnect gauges from service ports.

Figure 10

STEP 4 -- LEAK TEST AND EVACUATION (Continued)

3 EVACUATION

CONNECT GAUGE SET

NOTE — Remove cores from service valves (if not already done).

- Connect low side of manifold gauge set with 1/4 SAE in-line tee to *vapor* line service valve
- Connect high side of manifold gauge set to *liquid* line service valve
- Connect available micron gauge connector on the 1/4 SAE in-line tee.
- Connect the vacuum pump (with vacuum gauge) to the center port of the manifold gauge set. The center port line will be used later for both the HFC-410A and nitrogen containers.

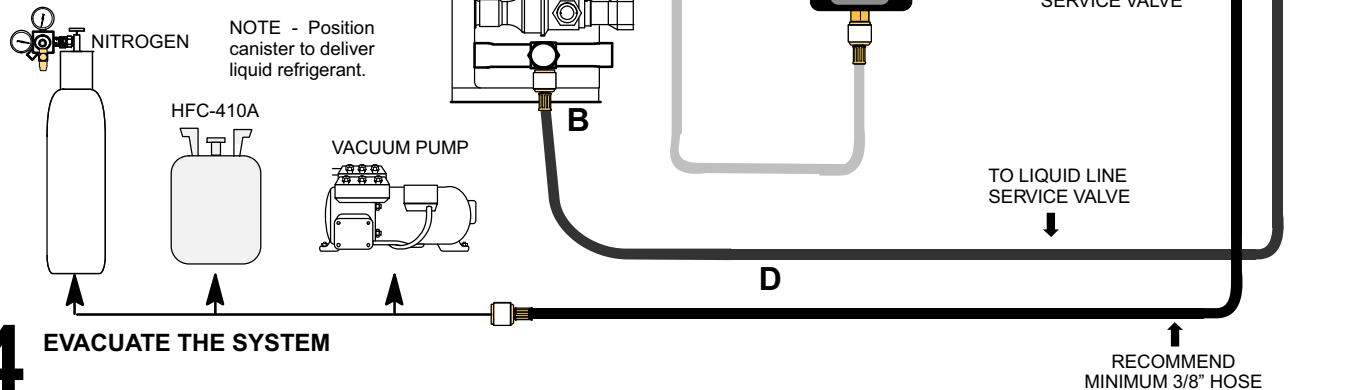

4

EVACUATE THE SYSTEM

- Open both manifold valves and start the vacuum pump.
- Evacuate the line set and indoor unit to an **absolute pressure** of 23,000 microns (29.01 inches of mercury).

NOTE — During the early stages of evacuation, it is desirable to close the manifold gauge valve at least once. A rapid rise in pressure indicates a relatively large leak. If this occurs, **repeat the leak testing procedure**.

NOTE — The term **absolute pressure** means the total actual pressure within a given volume or system, above the absolute zero of pressure. Absolute pressure in a vacuum is equal to atmospheric pressure minus vacuum pressure.
- When the absolute pressure reaches 23,000 microns (29.01 inches of mercury), perform the following:
 - Close manifold gauge valves.
 - Close valve on vacuum pump.
 - Turn off vacuum pump.
 - Disconnect manifold gauge center port hose from vacuum pump.
 - Attach manifold center port hose to a nitrogen cylinder with pressure regulator set to 150 psig (1034 kPa) and purge the hose.
 - Open manifold gauge valves to break the vacuum in the line set and indoor unit.
 - Close manifold gauge valves.
- Shut off the nitrogen cylinder and remove the manifold gauge hose from the cylinder. Open the manifold gauge valves to release the nitrogen from the line set and indoor unit.
- Reconnect the manifold gauge to the vacuum pump, turn the pump on, and continue to evacuate the line set and indoor unit until the absolute pressure does not rise above 500 microns (29.9 inches of mercury) within a 20-minute period after shutting off the vacuum pump and closing the manifold gauge valves.
- When the absolute pressure requirement above has been met, disconnect the manifold hose from the vacuum pump and connect it to a cylinder of HFC-410A positioned to deliver liquid refrigerant. Open the manifold gauge valve 1 to 2 psig in order to release the vacuum in the line set and indoor unit.
- Perform the following:
 - Close manifold gauge valves.
 - Shut off HFC-410A cylinder.
 - Reinstall service valve cores by removing manifold hose from service valve. Quickly install cores with core tool while maintaining a positive system pressure.
 - Replace stem caps and finger tighten them, then tighten an additional one-sixth (1/6) of a turn as illustrated.

WARNING !

Possible equipment damage.

Avoid deep vacuum operation. Do not use compressors to evacuate a system. Extremely low vacuum can cause internal arcing and compressor failure. Damage caused by deep vacuum operation will void warranty.

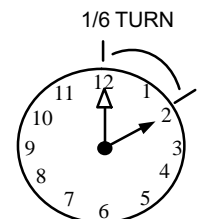

Figure 11

STEP 5 -- ELECTRICAL -- Circuit Sizing and Wire Routing

In the U.S.A., wiring must conform with current local codes and the current National Electric Code (NEC). In Canada, wiring must conform with current local codes and the current Canadian Electrical Code (CEC).

Refer to the furnace or air handler installation instructions for additional wiring application diagrams and refer to unit nameplate for minimum circuit ampacity and maximum overcurrent protection size.

24VAC TRANSFORMER

Use the transformer provided with the furnace or air handler for low-voltage control power (24VAC - 40 VA minimum)

⚠ WARNING



Electric Shock Hazard. Can cause injury or death. Unit must be grounded in accordance with national and local codes.

Line voltage is present at all components when unit is not in operation on units with single-pole contactors. Disconnect all remote electric power supplies before opening access panel. Unit may have multiple power supplies.

IMPORTANT !

If unit is equipped with a crankcase heater, it should be energized 24 hours before unit start-up to prevent compressor damage as a result of slugging.

⚠ CAUTION

ELECTROSTATIC DISCHARGE (ESD) Precautions and Procedures

Electrostatic discharge can affect electronic components. Take care during unit installation and service to protect the unit's electronic controls. Precautions will help to avoid control exposure to electrostatic discharge by putting the unit, the control and the technician at the same electrostatic potential. Touch hand and all tools on an unpainted unit surface before performing any service procedure to neutralize electrostatic charge.

1 SIZE CIRCUIT AND INSTALL DISCONNECT SWITCH

Refer to the unit nameplate for minimum circuit ampacity, and maximum fuse or circuit breaker size (HACR per NEC). Install power wiring and properly sized disconnect switch.

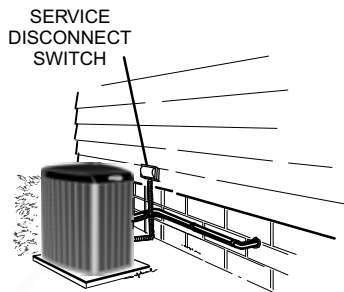

NOTE — Units are approved for use only with copper conductors. Ground unit at disconnect switch or connect to an earth ground.

2 INSTALL THERMOSTAT

Install room thermostat (ordered separately) on an inside wall in the center of the conditioned area and 5 feet (1.5m) from the floor. The thermostat should not be installed on an outside wall or where it can be affected by sunlight or drafts.

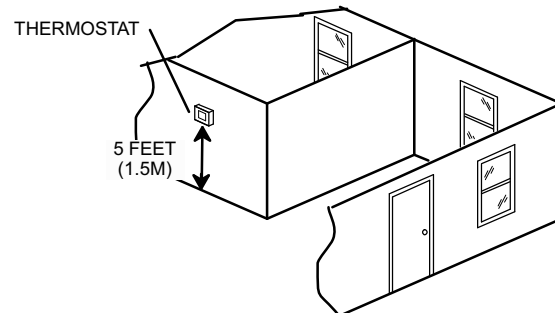

NOTE — 24VAC, Class II circuit connections are made in the control box.

Figure 12

3 A. ROUTE CONTROL WIRES — NON-COMMUNICATING

Install low voltage control wiring from outdoor to indoor unit and from thermostat to indoor unit. All low voltage wiring must enter unit through provided field-installed busing installed in electrical inlet.

Run 24VAC control wires through hole with grommet.
Make 24VAC control wire connections to heat pump control (A175).

NOTE — Do not bundle any excess 24VAC control wires inside control box.

NOTE — Wire tie provides low voltage wire strain relief and maintains separation of field-installed low and high voltage circuits.

NOTE — For proper voltages, select control wires gauge per table below.

WIRE RUN LENGTH	AWG#	INSULATION TYPE
LESS THAN 100' (30 METERS)	18	TEMPERATURE RATING
MORE THAN 100' (30 METERS)	16	35°C MINIMUM.

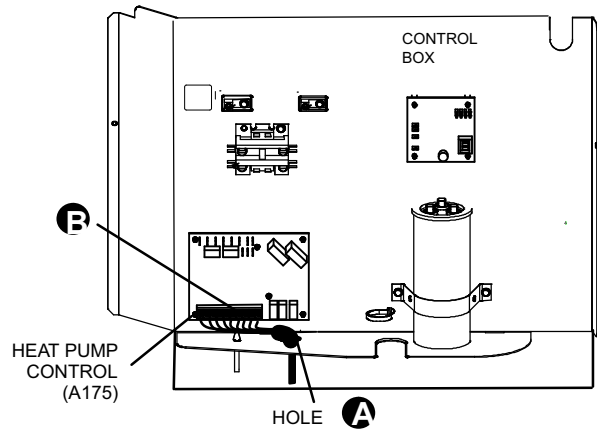

B. ROUTE CONTROL WIRES — COMMUNICATING

Maximum length of wiring (18 gauge) for all connections on the RSBus is 1500 feet (457 meters). Wires should be color-coded, with a temperature rating of 95°F (35°C) minimum, and solid-core (Class II Rated Wiring). All low voltage wiring must enter unit through provided field-installed busing installed in electrical inlet.

Communicating systems using the icomfort™-enabled thermostat require four thermostat wires between the thermostat and the furnace/air handler control and four wires between the outdoor unit and the furnace/air handler control. When a thermostat cable with more than four wires is used, the extra wires must be properly connected to avoid electrical noise. The wires must not be left disconnected.

Use a wire nut to bundle the four unused wires at each end of the cable. Each bundle should also include an additional wire that should be connected on each end to the C terminal as shown in the figure below.

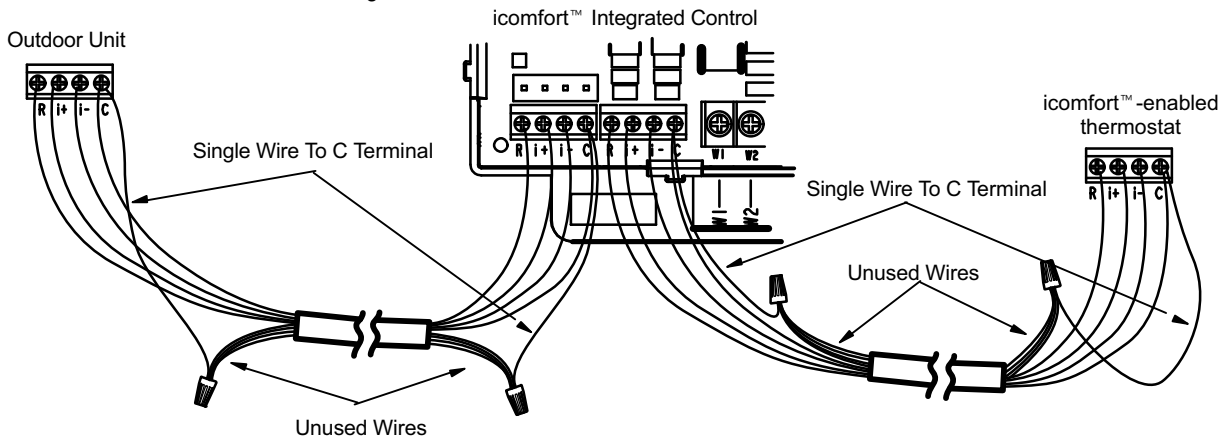

4 ROUTE HIGH VOLTAGE AND GROUND WIRES

Any excess high voltage field wiring should be trimmed and secured away from any low voltage field wiring. To facilitate a conduit, a cutout is located in the bottom of the control box. Connect conduit to the control box using a proper conduit fitting.

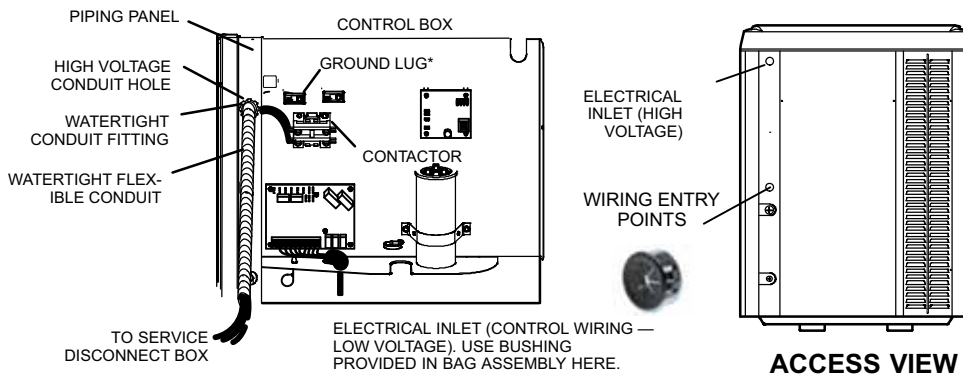

* Attach field-provided green ground wire to provided ground lug.

NOTE - Grounding wire must be a single, continuous wire run from unit ground lug to earth ground. **DO NOT splice wire.**

Figure 13

STEP 5 -- ELECTRICAL (Continued) -- Two-Stage Control (A175) Jumpers and Terminals

Communication System

The jumper settings and link are default settings and ONLY control system operation if configuration settings in the icomfort™-enabled thermostat are not available.

The Lennox icomfort™-enabled thermostat must be used in communicating applications.

Non-Communicating System

The unit will operate based on jumper settings and R-TO-DS link on the MAIN CONTROL. All unit setting changes must be done at the MAIN CONTROL. The Lennox ComfortSense® 7000 thermostat may be used, as well as other non-communicating electronic-only thermostats.

NOTE — Fan cycling routine when activated will cycle the fan ON for five minutes if the outdoor ambient air temperature is between 15°F and 35°F and the compressor has been OFF for 25 to 30 minutes. This option is to help reduce the potential for ice build up on the orifice ring during system OFF cycles that are greater than 25 to 30 minutes.

Set up of jumpers on replacement outdoor control.

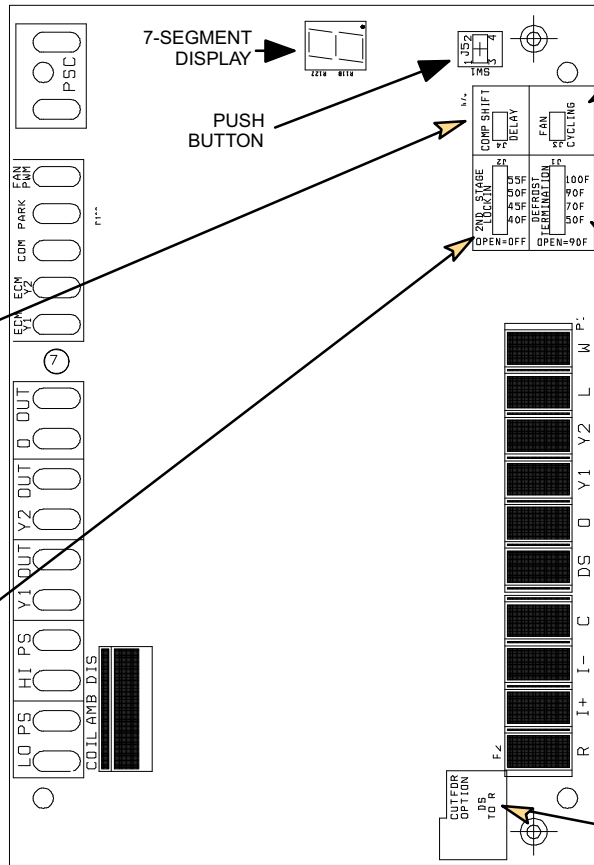

J3 ALL UNITS) FAN CYCLING

JUMPER ON
FAN ON FOR 5 MINUTES

JUMPER OFF
DISABLE (DEFAULT)

SEE NOTE ABOVE FOR FURTHER DETAILS.

J1 (HP ONLY) DEFROST TERMINATION TEMPERATURE

100 DEGREE TARGET

90 DEGREE TARGET

70 DEGREE TARGET

50 DEGREE TARGET (DEFAULT)

(DEFAULT WHEN JUMPER IS REMOVED OR MISSING)

DS TO R TWO-STAGE UNIT ONLY)

Cut for Humiditrol® - Enhanced Dehumidification Accessory (EDA) applications.

NOTE - LINK NOT APPLICABLE TO ONE-STAGE UNITS. CUTTING LINK WILL HAVE NO AFFECT ON OPERATION OF ONE-STAGE UNITS.

Figure 14

STEP 5 -- ELECTRICAL (Continued) -- Field Control Wiring

The following two illustrations provide examples of control wiring connections when using a non-communicating thermostat. For examples of control wiring in complete or partial communicating systems, see the icomfort™ -enabled thermostat **Quick Start Guide** which is provided with the thermostat.

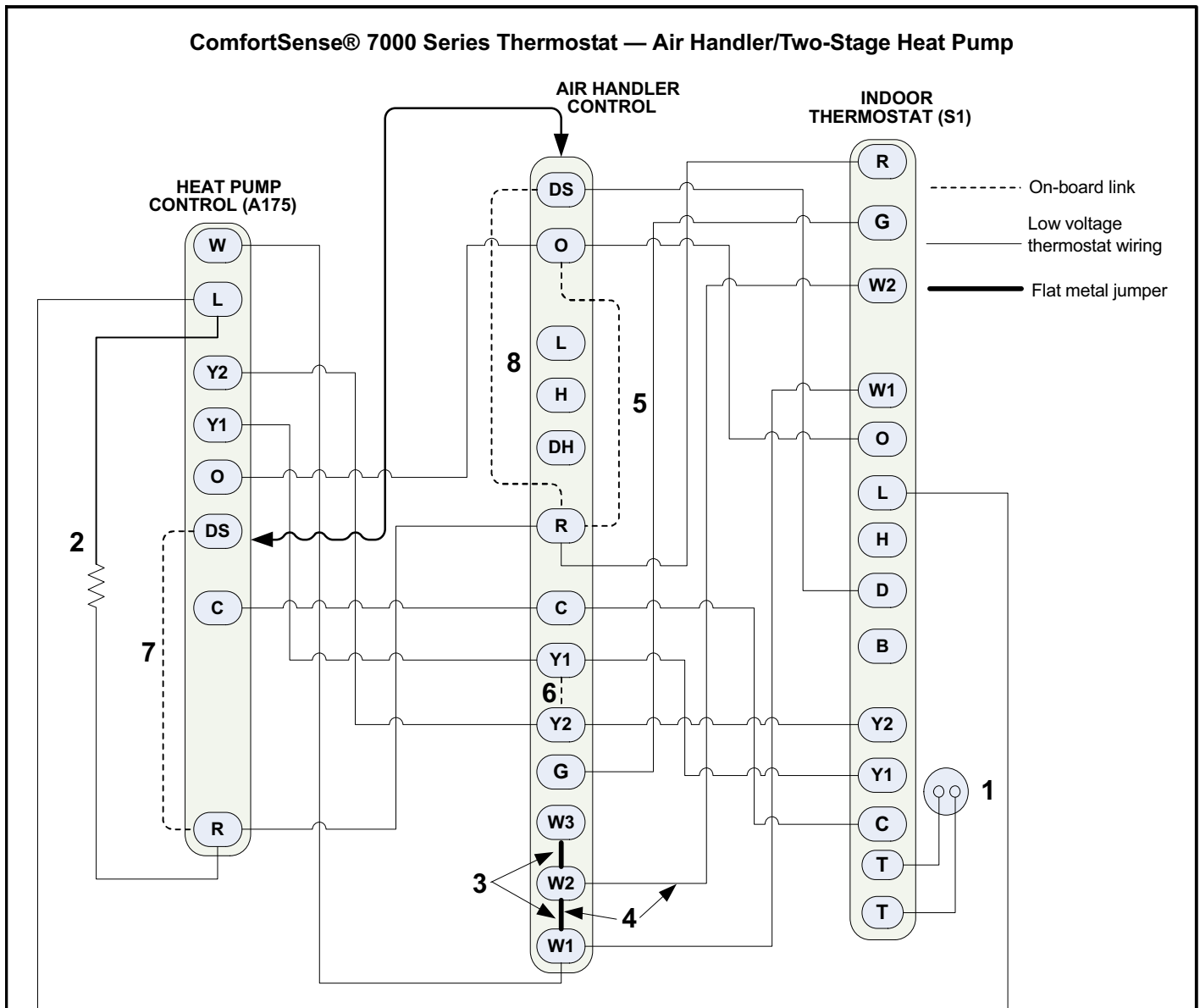

- A.. Thermostat **T** terminals are used for outdoor sensor input. This is required for use of thermostat's optional outdoor temperature display and balance points.
- B.. **R** to **L** connection is required for this model when using the ComfortSense® 7000 - catalog number Y0349 only. Resistor kit (catalog number 47W97) required and ordered separately.
- C.. Air handler control ships from factory with metal jumpers installed across **W1**, **W2** and **W3**. For one-stage electric heat, do not remove factory-installed metal jumpers.
- D.. Air handler control ships from factory with metal jumpers installed across **W1**, **W2** and **W3**. For two-stage electric heat, remove factory-installed metal jumper between **W1** to **W2**. Then connect thermostat wire between the air handler control's **W2** terminal and the thermostat's **W2** terminal.
- E.. Cut on-board link from **R-O HEAT PUMP** for heat pump applications.
- F.. Cut on-board link from **Y1-Y2 2 STAGE COMPR** for two-stage compressor and two-speed fan operation.
- G.. Cut loop jumper **DS** to **R** on two-stage units for Humiditrol® whole-home dehumidification system applications. This will slow the outdoor unit's fan speed to a specific RPM. A wire must be installed between the **DS** terminals on the furnace and outdoor unit controls.
- H.. Cut on-board link **DS-R** for Humiditrol® whole-home dehumidification system or Harmony III™ zoning system applications. This will slow the indoor blower motor to the lowest speed setting. See air handler installation instruction or engineering handbook for lowest fan speed information.

Figure 15

ComfortSense® 7000 Series Thermostat — Furnace/Two-Stage Heat Pump

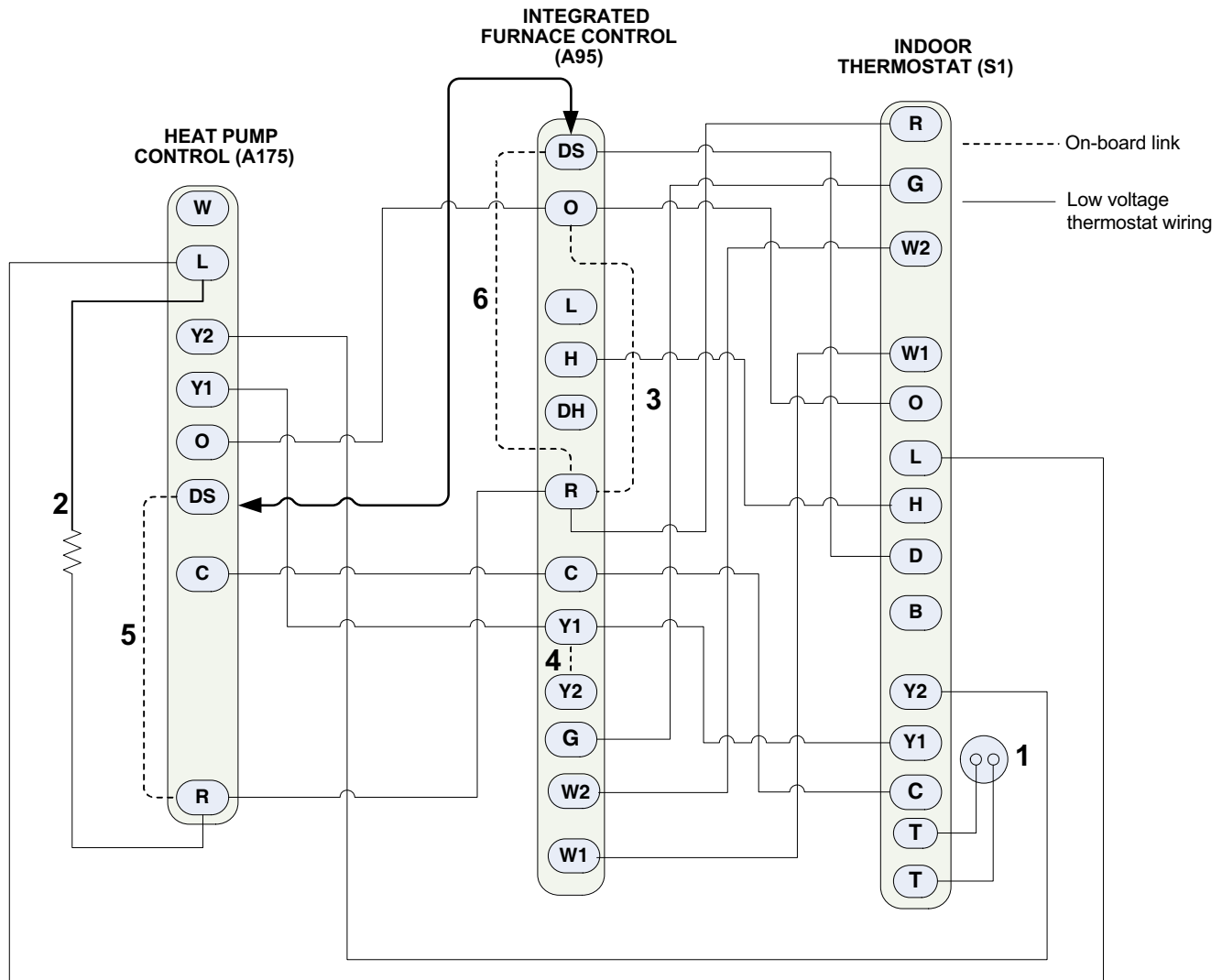

- A.. Thermostat **T** terminals are used for outdoor sensor input. This is required for use of thermostat's optional outdoor temperature display and balance points.
- B.. **R** to **L** connection is required when using the ComfortSense® 7000 - catalog number Y0349 only. A resistor kit (catalog number 47W97) is required and must be ordered separately.
- C.. Cut on-board link **W951** from **R-O HEAT PUMP** for heat pump applications.
- D.. Cut on-board link **W915** for two-stage operation.
- E.. Cut loop jumper **DS to R** on two-stage units for Humiditrol® whole-home dehumidification system applications. This will slow the outdoor unit's fan speed to a specific RPM. A wire must be installed between the **DS** terminals on the furnace and outdoor unit controls.
- F.. Cut on-board link **DS-R** for Humiditrol® whole-home dehumidification system or Harmony III™ zoning system applications. This will slow the indoor blower motor to the lowest speed setting. See furnace installation instruction or engineering handbook for lowest fan speed information.

*NOTE - If the furnace is used to satisfy heating demand during defrost, the 67M41 temper kit is required and must be wired between the **W** terminal of the heat pump control (A175) and the **W1** terminal on the furnace control. The kit allows the furnace to cycle on and off during a defrost and protects the compressor from high pressures during defrost.*

Figure 16

WARNING

This product and/or the matching indoor unit may contain fiberglass wool.

Disturbing the insulation during installation, maintenance, or repair will expose you to fiberglass wool dust. Breathing this may cause lung cancer. (Fiberglass wool is known to the State of California to cause cancer.)

Fiberglass wool may also cause respiratory, skin, and eye irritation.

To reduce exposure to this substance or for further information, consult material safety data sheets available from address shown below, or contact your supervisor.

Lennox Industries Inc.
P.O. Box 799900
Dallas, TX 75379-9900

Heat Pump Control -- Defrost Operation

A full description of the heat pump control can be found in the detailed installation and service procedure manual available on DaveNet. The defrost termination pins (E47) must be set on the heat pump control prior to starting the system to ensure proper defrost operation.

The heat pump control (A175) measures differential temperatures to detect when the system is performing poorly because of frost build-up on the outdoor coil. The heat pump control self-calibrates when the defrost system starts and after each system defrost cycle. The heat pump control monitors ambient temperature, outdoor coil temperature, and total run-time to determine when a defrost cycle is required. The coil temperature sensor is designed with a spring clip to allow mounting to the outside coil tubing. The location of the coil sensor is important for proper defrost operation.

NOTE - The heat pump control accurately measures the performance of the system as frost accumulates on the outdoor coil. This typically will translate into longer running time between defrost cycles as more frost accumulates on the outdoor coil before the heat pump control initiates defrost cycles.

DEFROST OPERATING MODES

The heat pump control operational modes are:

- Defrost calibration and operation
- Defrost test

DEFROST TERMINATION TEMPERATURE (J1)

The heat pump control can be set to terminate the defrost cycle at 50, 70, 90, or 100°F (10, 21, 32 and 38°C) (see figure 14). The termination jumper is factory-set at 50°F (10°C). If the termination jumper is not installed, the default termination temperature is 90°F (32°C).

NOTE - Colder climates could require a higher defrost termination temperature setting to maintain a clear coil.

SECOND STAGE LOCK-IN (J2)

If first-stage compressor output is active in heating mode and the outdoor ambient temperature is below the selected compressor lock-in temperature, the second-stage compressor solenoid output will be energized even without a Y2 room thermostat input.

If the jumper is not connected to one of the temperature selection pins on E48 (40, 45, 50, 55°F) (see figure 14), the second stage lock-in feature is inactive. Factory default is 40°F.

FAN CYCLING (J3)

Fan cycling routine when activated will cycle the fan **ON** (see figure 14) for five minutes if the outdoor ambient air temperature is between 15°F and 35°F and the compressor has been **OFF** for 25 to 30 minutes. This option is to help reduce the potential for ice build up on the orifice ring during system **OFF** cycles that are greater than 25 to 30 minutes.

SHIFT DELAY (J4)

The heat pump control has a field-selectable shift delay (see figure 14) which will reduce the occurrence of sounds that may happen as the unit cycles in and out of the defrost mode. Units are shipped with the jumper positioned to provide a 30-second delay.

When the jumper is installed across both pins (factory setting), the 30-second shift delay de-energizes the compressor contactor and ECM fan outputs.

When the jumper is placed on a single pin, there is no delay between modes. The reversing valve is immediately de-energized to allow compressor operation in the heating mode following a defrost cycle. In addition, the outdoor fan is cycled on for five minutes, if the outdoor ambient temperature is between 15°F (-9.4°C) and 35°F (1.7°C) and the compressor has been off for 25 minutes.

Start-Up Checklists

TWO-STAGE COMPRESSOR PERFORMANCE

Use this procedure to verify part- and full-load capacity operation of the two-stage compressor.

IMPORTANT !

This performance check is **ONLY** valid on systems that have clean indoor and outdoor coils, proper airflow over coils, and correct system refrigerant charge. All components in the system must be functioning properly to correctly perform compressor operational check. (Accurate measurements are critical to this test as indoor system loading and outdoor ambient can affect variations between low and high capacity readings).

TOOLS REQUIRED

- Refrigeration gauge set
- Digital volt/amp meter
- Electronic temperature thermometer
- On-off toggle switch

PROCEDURE

- A. Turn main power OFF to outdoor unit.
- B. Adjust room thermostat set point 5°F above (heating operation) or 5°F below (cooling operation) the room temperature.
- C. Remove control access panel. Install refrigeration gauges on unit. Attach the amp meter to the common (black wire) wire of the compressor harness. Attach thermometer to discharge line as close as possible to the compressor.
- D. Turn toggle switch OFF. Install switch in series with Y2 wire from room thermostat. (See note ** in the *Field Operational Checklist* on page 19).
- E. Cycle main power ON.
- F. Allow pressures and temperatures to stabilize before taking any reading (may take up to 10 minutes).
- G. Record all of the readings for the Y1 demand.
- H. Close switch to energize Y2 demand. Verify power is going to compressor solenoid (see note ** in the *Field Operational Checklist* on page 19).
- I. Allow pressures and temperatures to stabilize before taking any reading (may take up to 10 minutes).
- J. Record all of the readings with the Y1 and Y2 demand.
- K. If temperatures and pressures change in the direction noted in chart, the compressor is properly modulating from low to high capacity. (If no amperage, pressures or temperature readings change when this test is performed, the compressor is not switching between low and high capacity and replacement is necessary.)
- L. After testing is complete, return unit to original set up.

HOMEOWNER INFORMATION

CAUTION

Before attempting to perform any service or maintenance, turn the electrical power to unit OFF at disconnect switch.

Cleaning of the outdoor unit's coil should be performed by a licensed professional service technician (or equivalent). Contact your dealer and set up a schedule (preferably twice a year, but at least once a year) to inspect and service your outdoor unit. The following maintenance may be performed by the homeowner.

IMPORTANT !

Sprinklers and soaker hoses should not be installed where they could cause prolonged exposure to the outdoor unit by treated water. Prolonged exposure of the unit to treated water (i.e., sprinkler systems, soakers, waste water, etc.) will corrode the surface of steel and aluminum parts, diminish performance and affect longevity of the unit.

Outdoor Coil

The outdoor unit must be properly maintained to ensure its proper operation.

- Please contact your dealer to schedule proper inspection and maintenance for your equipment.
- Make sure no obstructions restrict airflow to the outdoor unit.
- Grass clippings, leaves, or shrubs crowding the unit can cause the unit to work harder and use more energy.
- Keep shrubbery trimmed away from the unit and periodically check for debris which collects around the unit.
- Keep snow level below the louvered panels to ensure proper performance.

Routine Maintenance

In order to ensure peak performance, your system must be properly maintained. Clogged filters and blocked airflow prevent your unit from operating at its most efficient level.

NOTE — The filter and all access panels must be in place any time the unit is in operation. If you are unsure about the filter required for your system, call your Lennox dealer for assistance.

- A. Ask your Lennox dealer to show you where your indoor unit's filter is located. It will be either at the indoor unit (installed internal or external to the cabinet) or behind a return air grille in the wall or ceiling. Check the filter monthly and clean or replace it as needed.
- B. Disposable filters should be replaced with a filter of the same type and size.
- C. The indoor evaporator coil is equipped with a drain pan to collect condensate formed as your system removes humidity from the inside air. Have your dealer show you the location of the drain line and how to check for obstructions. (This would also apply to an auxiliary drain, if installed.)

Thermostat Operation

See the ComfortSense® 7000 or icomfort™ -enabled thermostat homeowner manual for instructions on how to operate your thermostat.

Heat Pump Operation

Your new Lennox heat pump has several characteristics that you should be aware of:

- Heat pumps satisfy heating demand by delivering large amounts of *warm* air into the living space. This is quite different from gas- or oil-fired furnaces or an electric furnace which deliver lower volumes of considerably *hotter* air to heat the space.
- Do not be alarmed if you notice frost on the outdoor coil in the winter months. Frost develops on the outdoor coil during the heating cycle when temperatures are below 45°F (7°C). The heat pump control activates a defrost cycle lasting 5 to 15 minutes at preset intervals to clear the outdoor coil of the frost.
- During the defrost cycle, you may notice steam rising from the outdoor unit. This is a normal occurrence. The thermostat may engage auxiliary heat during the defrost cycle to satisfy a heating demand; however, the unit will return to normal operation at the conclusion of the defrost cycle.

Extended Power Outage

The heat pump is equipped with a compressor crankcase heater which protects the compressor from refrigerant *slugging* during cold weather operation.

If power to your unit has been interrupted for several hours or more, set the room thermostat selector to the EMERGENCY HEAT setting to obtain temporary heat without the risk of serious damage to the heat pump.

In EMERGENCY HEAT mode, all heating demand is satisfied by auxiliary heat; heat pump operation is locked out. After a six-hour compressor crankcase warm-up period,

the thermostat can be switched to the HEAT setting and normal heat pump operation may resume.

Preservice Check

If your system fails to operate, check the following before calling for service:

- Verify room thermostat settings are correct.
- Verify that all electrical disconnect switches are ON.
- Check for any blown fuses or tripped circuit breakers.
- Verify unit access panels are in place.
- Verify air filter is clean.
- If service is needed, locate and write down the unit model number and have it handy before calling.

XP21 Field Operational Checklist						
Unit Readings	Cooling***			Heating***		
	Y1 First Stage	Expected results during Y2 demand (toggle switch ON)	Y2 Second Stage	Y1 First Stage	Expected results during Y2 demand (toggle switch ON)	Y2 Second Stage
Compressor						
Voltage		Same			Same	
Amperage		Higher			Higher	
Condenser Fan motor						
Amperage		Same or Higher			Same or Higher	
Temperature						
Ambient		Same			Same	
Outdoor Coil Discharge Air		Higher			Lower	
Compressor Discharge Line		Higher			Higher	
Indoor Return Air		Same			Same	
Indoor Coil Discharge Air		Lower			Higher	
Pressures						
Suction (Vapor)		Lower			Down	
Liquid		Higher			Higher	
<p>Note - Heat pump may have a low ambient control or control that locks in second-stage operation below its set point. It may be necessary to remove a wire from the control when performing this check.</p> <p>** On the XP21 units, the System Operation Monitor controls the second-stage solenoid coil in compressor.</p> <p>*** Cooling Mode Operation - Block outdoor coil to maintain a minimum of 375 psig during testing. Heating Mode Operation - Block indoor coil to maintain a minimum of 375 psig during testing.</p>						

XP21 Start-Up and Performance Checklist

Customer _____ Address _____

Indoor Unit Model _____ Serial _____

Outdoor Unit Model _____ Serial _____

Solar Module Mfg and Model _____ Serial _____

Notes: _____

START-UP CHECKS

Refrigerant Type: ____

Rated Load Amps ____ Actual Amps _____ Rated Volts _____ Actual Volts _____

Condenser Fan Full Load Amps _____ Actual Amps: _____

COOLING MODE

Vapor Pressure: ____ Liquid Pressure: _____

Supply Air Temperature: _____ Ambient Temperature: _____ Return Air Temperature: _____

HEATING MODE

Vapor Pressure: ____ Liquid Pressure: _____

Supply Air Temperature: _____ Ambient Temperature: _____ Return Air Temperature: _____

System Refrigerant Charge (Refer to manufacturer's information on unit or installation instructions for required subcooling and approach temperatures.)

Subcooling:

$$\begin{array}{ccccccc} \text{Saturated Condensing Temperature (A)} & A & - & B & = & \text{SUBCOOLING} \\ \text{minus Liquid Line Temperature (B)} & & & & & \end{array}$$

Approach:

$$\begin{array}{ccccccc} \text{Liquid Line Temperature (A)} & A & - & B & = & \text{APPROACH} \\ \text{minus Outdoor Air Temperature (B)} & & & & & \end{array}$$

Indoor Coil Temp. Drop (18 to 22°F)

$$\begin{array}{ccccccc} \text{Return Air Temperature (A)} & A & - & B & = & \text{COIL TEMP DROP} \\ \text{minus Supply Air Temperature (B)} & & & & & \end{array}$$