

REPLACEMENT COLD END HEADER BOX

INSTALLATION INSTRUCTIONS FOR COLD END HEADER BOX KITS (86W25, 86W26 & 86W27) USED FOR SLP98DFV UNITS

Shipping & Packing List

Package 1 of 1 contains:

- 1 - Cold end header box (CEHB)
- 1 - Heat plate
- 1 - Foam blanket
- 2 - Self-drilling screws

Application

Use kits 86W25, 86W26 and 86W27 to replace the cold end header box and install the heat plate and foam blanket on SLP98DFV units. See table 1 for SLP98DFV unit input per kit.

⚠ WARNING

This kit is to be installed by a licensed professional service technician (or equivalent) or other qualified agency in accordance with the manufacturer's instructions, all codes and requirements of the authority having jurisdiction in the USA, and the requirements of the CSA-B149 installation codes in Canada. If the information in these instructions is not followed exactly, personal injury or loss of life may occur. The qualified agency performing this work assumes responsibility for this conversion.

⚠ CAUTION

Before attempting to perform any service or maintenance, turn the electrical power to unit OFF at disconnect switch.

**TABLE 1
Upgrade Kits**

SLP98 Model Input	Cold End Header Box Kit
070	86W25
090	86W26
110	86W26

Installation

1. -Turn off power to unit.
2. -Remove access panel.
3. -Disconnect the condensate drain trap from the CEHB.

4. -Remove the tubing and disconnect the wires from the pressure switch. Label wires and tubing making note of tubing color and negative and positive pressure switch ports.
5. -Remove the pressure switch by carefully pressing the tab which secures the switch assembly to the cold end header box. See figure 1.
6. -Disconnect the electrical power wiring harness from the combustion air inducer. Disconnect the ground wire if separate from the plug.
7. -Loosen clamps securing exhaust fitting to combustion air inducer.
8. -Disconnect the condensate drain tube from the CEHB.
9. -Loosen the clamp securing the black exhaust/drain elbow and remove.
10. -Loosen the clamps securing the flexible white air intake coupling and remove.
11. -Remove screws (set aside) which secure combustion air inducer to CEHB. Remove combustion air inducer assembly and set aside.
12. -Remove screws securing CEHB to vestibule panel. Set screws aside. Discard CEHB.
13. -Install replacement CEHB (box should be level) using existing screws.
14. -Using the provided self-drilling screws, secure the heat plate to the heat exchanger vestibule.
15. -Re-install the pressure switch. Reconnect wires to the pressure switch. Take extra care not to bend terminals. See figure 3 for proper tubing location.
16. -Remove backing from foam blanket and apply making sure the screw holes on the blanket are aligned with screw holes on the CEHB. See figure 2.
17. -Use the existing screws and to reinstall combustion air inducer to the CEHB. Use a torque wrench to tighten screws to 30 in. lbs.
18. -Reconnect the electrical power wiring harness to the combustion air inducer. Reconnect the the ground wire if separate from the plug.
19. -Reinstall the black exhaust/drain elbow, tighten clamps to secure.
20. -Reconnect the condensate drain tube to the CEHB.
21. -Reinstall the flexible white air intake coupling, tighten clamps to secure.
22. -Reconnect the condensate drain trap to the CEHB and prime trap.
23. -Follow UNIT START UP procedure in unit Installation and Operation Manual provided with the unit.



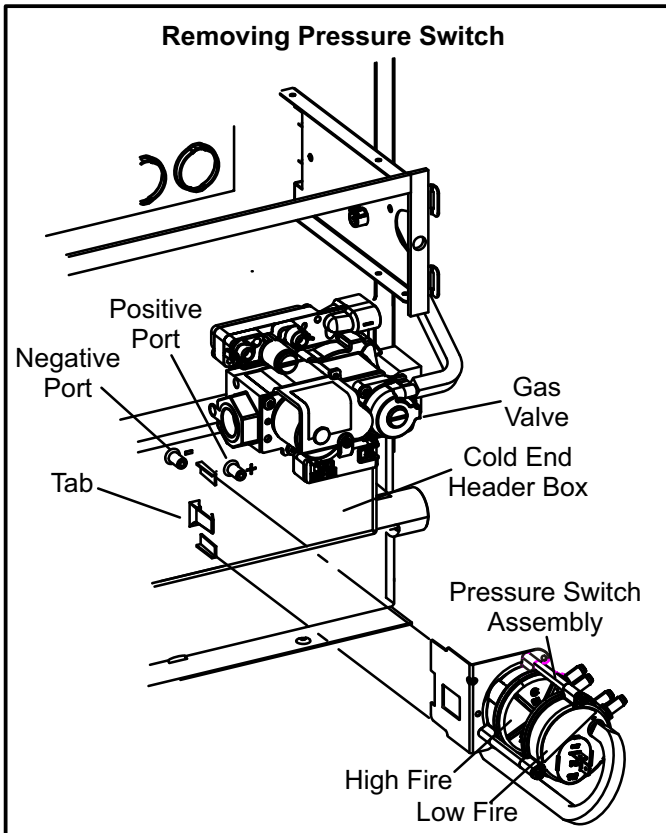

FIGURE 1

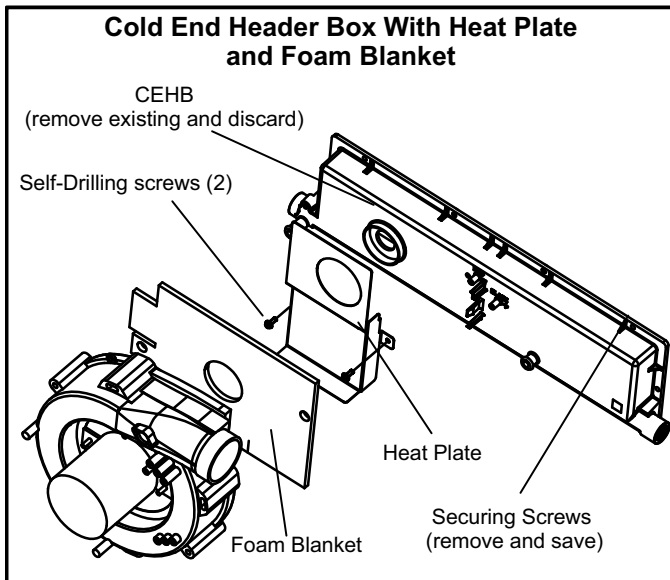

FIGURE 2

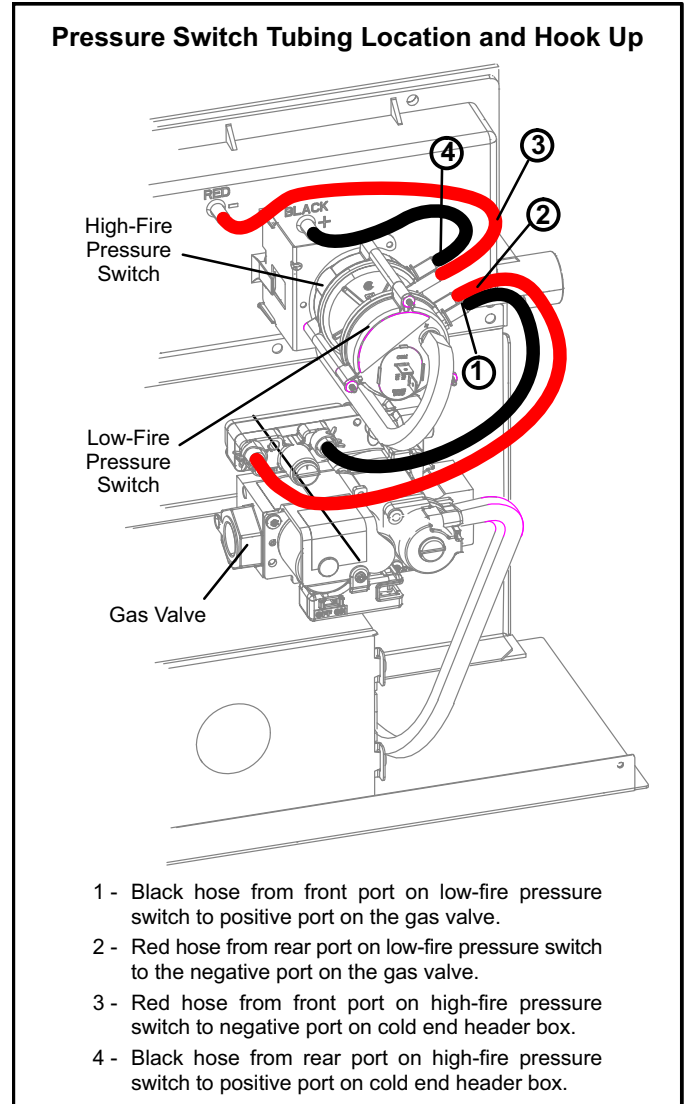

FIGURE 3